

SPECIAL PUBLICATION 18-94

# IMPROVING SAFETY AT SMALL UNDERGROUND MINES

Proceedings: Bureau of Mines Technology Transfer Seminar

Compiled by Robert H. Peters



United States Department of the Interior  
Bureau of Mines  
1994



*U.S. Department of the Interior  
Mission Statement*

As the Nation's principal conservation agency, the Department of the Interior has responsibility for most of our nationally-owned public lands and natural resources. This includes fostering sound use of our land and water resources; protecting our fish, wildlife, and biological diversity; preserving the environmental and cultural values of our national parks and historical places; and providing for the enjoyment of life through outdoor recreation. The Department assesses our energy and mineral resources and works to ensure that their development is in the best interests of all our people by encouraging stewardship and citizen participation in their care. The Department also has a major responsibility for American Indian reservation communities and for people who live in island territories under U.S. administration.

**Special Publication 18-94**

# **Improving Safety at Small Underground Mines**

**Compiled by Robert H. Peters**

**UNITED STATES DEPARTMENT OF THE INTERIOR  
Bruce Babbitt, Secretary**

**BUREAU OF MINES**

## CONTENTS

|   | <i>Page</i> |
|---|-------------|
| Abstract .....  | 1           |
| Introduction .....  | 2           |
| Statistical Profile of Accidents at Small Underground Coal Mines, by Robert H. Peters and Barbara Fotta ..  | 5           |
| Pillar Design and Strategies for Retreat Mining, By Frank E. Chase and Christopher Mark .....   | 15          |
| Shiftwork: A Guide for Schedule Design, By James C. Duchon .....  | 24          |
| Nature and Cost of Low Back Pain, by Sean Gallagher and Christopher A. Hamrick .....  | 37          |
| A Scientific Look at Back Belts, by Sean Gallagher and Christopher A. Hamrick .....   | 44          |
| Job Design: An Effective Strategy for Reducing Back Injuries, by Christopher A. Hamrick and Sean<br>Gallagher .....   | 48          |
| Developing and Maintaining Safety Programs for Improved Worker Performance: Don't Forget the Basics,<br>by Michael J. Klishis and Ronald C. Althouse .....                            | 55          |
| Emergency Response Planning for Small Mines: Who Needs It?, by Launa Mallett, Michael J. Brnich, Jr.,<br>and Charles Vaught .....   | 71          |
| Experimental Training To Reduce Variability in the Interpretation and Application of Machine Guarding<br>Requirements, by Lynn L. Rethi and William J. Wiehagen .....                 | 102         |
| Ergonomic and Statistical Assessment of Safety in Deep-Cut Mining, by Lisa J. Steiner, Fred C. Turin, and<br>Christopher A. Hamrick .....   | 124         |
| Crewstation Analysis Programs—An Easy To Use Personal Computer-Based Lighting and Visibility Analysis<br>Software Package for Underground Mining Equipment, by Richard L. Unger ..... | 133         |
| Impact of Maintainability Design on Injury Rates and Maintenance Costs for Underground Mining<br>Equipment, by Richard L. Unger and Kirk Conway .....                                 | 140         |
| Inexpensive, Easy To Construct Materials-Handling Devices for Underground Mines, by Richard L. Unger<br>and Kirk Conway .....   | 168         |



### UNIT OF MEASURE ABBREVIATIONS USED IN THIS REPORT

|                   |                          |       |                               |
|-------------------|--------------------------|-------|-------------------------------|
| cd/m <sup>2</sup> | candela per square meter | kg/h  | kilogram per hour             |
| cm                | centimeter               | lb    | pound                         |
| d/wk              | day per week             | lx    | lux                           |
| d/yr              | day per year             | m     | meter                         |
| fc                | footcandle               | min   | minute                        |
| fL                | foot lambert             | min/d | minute per day                |
| ft                | foot                     | mm Hg | millimeter of mercury         |
| h                 | hour                     | MPa   | megapascal                    |
| h/d               | hour per day             | psi   | pound (force) per square inch |
| h/yr              | hour per year            | st    | short ton                     |
| in                | inch                     | st/yr | short ton per year            |
| kg                | kilogram                 | t/h   | ton (metric) per hour         |

Reference to specific products does not imply endorsement by the U.S. Bureau of Mines.

# IMPROVING SAFETY AT SMALL UNDERGROUND MINES

Proceedings: Bureau of Mines Technology Transfer Seminar

Compiled by Robert H. Peters<sup>1</sup>

---

## ABSTRACT

This U.S. Bureau of Mines report identifies the types of serious accidents that occur most frequently at small underground coal mines and describes the strategies that could help prevent these accidents. A wide variety of methods for improving safety are suggested, including improvements in the design of equipment, work procedures, work schedules, safety programs, and emergency response plans, as well as techniques for diagnosing the potential hazards associated with new technologies and work procedures. Some of the papers in this volume focus on preventing specific types of mining accidents—ones associated with materials handling (primarily back injuries), equipment maintenance, improper machine guarding, and ground failure during retreat mining. Although the recommendations in this volume are heavily influenced by research performed at underground coal mines in the Appalachian coalfields, most of the papers contain advice that is equally pertinent to almost any type of mine.

---

<sup>1</sup>Research psychologist, Pittsburgh Research Center, U.S. Bureau of Mines, Pittsburgh, PA.

## INTRODUCTION

### BACKGROUND

The vast majority of underground coal mines in the United States are relatively small operations. Of the 1,345 U.S. underground coal mines in operation during 1992, about one-half (638) employed 20 or fewer people and about one-third (454) employed between 20 and 50 people. The median number of employees was 22. Mines of fewer than 50 employees accounted for 26% of total underground coal production and 28% of the total number of hours worked in underground mines.

Unfortunately, small mines seem to account for far more than their share of total fatalities. Although small mines (50 or fewer employees) accounted for only about 28% of the total work force, they accounted for 66% of the fatalities that occurred in 1992. These statistics are not too different from other recent years. During the period 1989-91, 58% of the fatalities occurred at mines of fewer than 50 employees.

To assist small mine operators with improving safety, the U.S. Bureau of Mines (USBM) is conducting a series of technology transfer seminars at multiple locations within the four States that contain most of the small underground coal mines in the United States—Kentucky, West Virginia, Virginia, and Pennsylvania. This report was prepared to summarize the information presented at these seminars. It contains 13 papers on various issues related to safety at small underground coal mines. These papers describe a wide variety of approaches to improve mine safety: modifications to the design of mining equipment, work procedures, and work schedules; development of effective safety programs and emergency response plans; and techniques for diagnosing the potential hazards associated with new technologies and work procedures. Some of the papers focus on preventing specific types of mining accidents, such as back injuries and roof falls.

Ground control is a particularly important problem at small mines. Roof falls are the most frequent cause of fatalities at small underground coal mines, accounting for over one-half (56%) of all fatal accidents. The Peters and Fotta (6)<sup>2</sup> analysis of accident statistics indicates that, in comparison to large mines (over 50 employees), the rate of groundfall fatalities is 10 times higher at mines with 20 or fewer employees. This volume contains only one paper on this topic (1). However, the USBM conducted several seminars on preventing groundfall accidents at small mines during 1992-93. The eight papers prepared for those seminars are published in a proceedings volume—USBM Information Circular (IC) 9332 (8).

Back injuries are the most frequent type of nonfatal injuries at small underground mines. These injuries are a major problem for both employers and employees. Back injuries are responsible for a great deal of suffering and account for from 30% to 40% of worker compensation costs at underground coal mines. Miners working in thin-seam mines must handle materials and perform other duties while in unusual and somewhat awkward postures, resulting in stress to the lower back. Four of the papers in this volume address various aspects of miners' back injuries and how to prevent them (2-4, 7).

The major causes of fatalities and serious injuries at underground coal mines are basically the same regardless of the size of the mine. The recommendations contained in this volume are generally just as applicable to large mines as they are to small mines. However, because of greater limitations on work force and capital, the alternatives for solving certain types of safety problems may be more limited for small mines than for larger operations. The authors of this volume have been encouraged to concentrate on proposing solutions that would be feasible for implementation at most small mining companies. However, large mining operations may be able to solve certain types of safety problems via strategies that would not be feasible for most small mining operations (e.g., major changes in equipment or mining techniques).

Several hypotheses have been proposed to try to account for why fatality rates are so much higher at small mines (5, 9). However, there is almost no research evidence available indicating whether or not any of them are valid. Data need to be collected and analyzed to evaluate the impact of various factors on safety at small mines. The National Academy of Sciences (5) researchers analyzed data on a variety of factors that sounded like plausible explanations for the difference between fatality rates at small mines versus large mines, but found that none of them were capable of accounting for the large differences that exist. It is clear that small mines differ from large mines in several respects (e.g., seam height and longevity of operation), but it remains to be determined whether these differences are of any significance in explaining why small mines have higher fatality rates.

During the 1980's, there was a substantial decline in the number of underground coal mines and in the number of jobs for miners in the United States. The number of mines in the United States declined by 32% and the number of hours employees worked in underground coal mines declined by 40%. These dramatic changes have no doubt influenced mine safety in various ways. In some respects, these changes may have improved miners' safety and, in other respects, they may have worsened it. There is currently very little in the way of theory or data on

<sup>2</sup>Italic numbers in parentheses refer to items in the list of references at the end of this introduction.

which to base any predictions or arguments. However, future safety researchers and economists may wish to explore how mine closures and the threat of job loss impact safety and whether the impact varies across mine size.

### PLANS FOR FUTURE RESEARCH

The USBM plans to conduct further analyses of existing data to try to determine if there are characteristics of mines or miners that tend to vary with mine size and whether any of these factors are significantly related to variations in fatality rates. Very little information is available concerning what small mine operators are currently doing to ensure their employees' safety. It is very difficult to determine what types of changes are needed without having a better picture of what small mine operators are currently doing and what kinds of constraints and opportunities for improving safety exist at these operations. Therefore, the USBM plans to conduct structured interviews with underground coal miners, mine

owners, and mine inspectors to find out more about the approaches small mine operators are currently using to prevent accidents and what the people who work at small mines perceive as the obstacles to maintain a safe workplace. Once this information has been collected, it will be summarized and published, and the USBM will assist, if possible, with implementing any recommendations.

### REFERENCES

1. Chase, F. E., and C. Mark. Pillar Design and Strategies for Retreat Mining. Paper in this proceedings.
2. Gallagher, S., and C. A. Hamrick. Nature and Cost of Low Back Pain. Paper in this proceedings.
3. \_\_\_\_\_. A Scientific Look at Back Belts. Paper in this proceedings.
4. Hamrick, C. A., and S. Gallagher. Job Design: An Effective Strategy for Reducing Back Injuries. Paper in this proceedings.
5. National Academy of Sciences. Fatalities in Small Underground Coal Mines (contract J0100145). BuMines OFR 124-83, 1983, 20 pp.
6. Peters, R. H., and B. Fotta. Statistical Profile of Accidents at Small Underground Coal Mines. Paper in this proceedings.



# STATISTICAL PROFILE OF ACCIDENTS AT SMALL UNDERGROUND COAL MINES

By Robert H. Peters<sup>1</sup> and Barbara Fotta<sup>2</sup>

---

## ABSTRACT

The U.S. Bureau of Mines prepared this paper to provide statistical information on accidents, production, and employment at small U.S. underground coal mines. Mines are categorized according to size as follows: fewer than 20 employees, 20 to 50 employees, 50 to 100 employees, and more than 100 employees. For each size category, statistics are presented showing the following: (1) the number of mines and the States in which they are located; (2) changes in employment, production, and rates of fatal and permanently disabling accidents between two periods (1978-80 and 1989-91); and (3) rates of coal production

and rates of various types of serious accidents. The five States with the largest number of small underground coal mines are Kentucky, West Virginia, Virginia, Pennsylvania, and Tennessee. Statistics are presented to show how various sizes of mines in these 5 States compare with one another in terms of safety and productivity. Statistics are also presented showing how miners who are injured while working at mines of various sizes compare in terms of age and experience. Several propositions about why small mines have higher fatality rates are reviewed.

## INTRODUCTION

The National Academy of Sciences (NAS) published studies (5-6)<sup>3</sup> in 1982 and 1983 examining the relationship between the size of underground coal mines and the rate of fatal accidents. It found that during the period 1978-80, the fatality rate for mines with 50 or fewer employees (0.14) was about 3 times that of mines with over 250 employees (0.05), and almost twice that of mines with 51 to 250 employees (0.08). The researchers note:

This strong correlation between mine size and fatality rates was evident in all the data from the [U.S.] Mine Safety and Health Administration (MSHA) we examined dating back to 1969. Furthermore, the association was not explainable by

company ownership, union status, seam thickness, or any of the other factors we examined.

More recent data from MSHA indicate that the discrepancy between fatality rates at small versus large mines has grown even more extreme since the NAS study was performed. Tisdale (8) writes:

In 1992, small underground coal mines, with fewer than 20 employees, had a fatal incidence rate of about 6 times that of larger mines, and those with more than 20 but fewer than 50 employees had a rate about 4 times that of larger mines.

The NAS researchers analyzed data on accidents at underground coal mines during the late 1970's to try to establish which of several factors might be responsible for the fact that fatality rates are so much higher at small mines. Their findings are reviewed briefly as follows:

---

<sup>1</sup>Research psychologist.

<sup>2</sup>Research methodologist.

Pittsburgh Research Center, U.S. Bureau of Mines, Pittsburgh, PA.

<sup>3</sup>Italic numbers in parentheses refer to items in the list of references at the end of this paper.

*Exposure to Face Areas of the Mine.*—One potential explanation of the association between mine size and fatality rates is that in large mines there are proportionally more workers away from the working face and therefore at reduced risk for a fatality. If this were true, then smaller mines would have larger fatality rates even though the risks for miners at the working face were the same as in larger mines. The NAS researchers allowed for this possibility in their analyses (6, pp. 91-93), but found that, at best, it could explain only a part of the strong association between mine size and fatality rates.

*Seam Thickness.*—The NAS researchers investigated the impact that seam height might have on explaining the differences between fatality rates at small versus large mines. They note that, in general, smaller mines have thinner coal seams than larger mines. However, they were unable to find any clear relationship between seam thickness and the fatality rate in small mines. In contrast, within each thickness category the fatality rate tends to decline with increasing mine size. Therefore, the authors concluded that the association between mine size and fatality rate is not due to differences between small and large mines with respect to seam thickness. However, about 78% of mines with 20 or fewer employees and 59% of mines with 21 to 50 employees failed to report seam heights for the period being studied (1975-80). Such a large amount of missing data precluded doing a thorough analysis of seam height relative to mine size. Unfortunately, it is impossible to determine the extent to which this lack of data may have influenced the results that were reported.

*Duration of Active Operation.*—The NAS (5) researchers note that there are striking differences between small and large mines with respect to the length of time they remain open. They note that smaller mines operate for shorter periods of time and more intermittently than larger mines, which tend to operate more or less continuously. The majority (57%) of small mines in their sample were active for 18 months or less during 1975-80, compared with only 4% of larger mines.

The NAS researchers hypothesized that part of the difference between fatality rates at small versus large mines may reflect a "learning curve" phenomenon. The reasoning behind this notion is that the risk of a fatality is greatest

shortly after a mine first opens and thereafter declines—i.e., the risk of fatalities decreases over time. Although this notion appears plausible, the NAS researchers could not find sufficient evidence from their data to support it.

The NAS findings strongly suggest that various factors that sounded like plausible explanations for the difference between fatality rates at small versus large mines are actually NOT capable of accounting for the large differences that exist. Unfortunately, researchers have yet to establish what the factors are that can account for the large disparity. The NAS (5) researchers speculate that the following factors may have been at least partly responsible for the disparity:

On the basis of our examination of fatality reports, discussions with operators of small underground coal mines, and the experience of the Committee's three mining engineers and geologist with small mine operations, we believe the following factors exacerbate the safety problem in small mines:

- 1) The mining equipment in small mines is of lower quality, sometimes secondhand, and less well maintained.
- 2) The physical condition of employees in small mines is less favorable to safety—small operators sometimes employ workers that large companies will not accept.
- 3) The financial resources available to operators of small mines are limited. Hence many of these operators are not able to support the more extensive safety programs employed by some major coal companies (using safety engineers and technicians).

Statistics on rates of fatalities and permanently disabling injuries strongly suggest that small mine operators face some unique obstacles to maintaining their employees' safety. The U.S. Bureau of Mines (USBM) prepared this paper to (1) update the NAS accident statistics, (2) identify changes that have occurred since 1980, and (3) enumerate the propositions that have been set forth to try to account for the differences in the safety performance of small versus large mines. The information this paper provides may be useful in arriving at causal explanations and successful interventions aimed at improving miners' safety—especially at small underground coal mines.

## METHODS

The data presented here are drawn from MSHA's database of mining production, employment, and accidents for the entire population of U.S. underground coal mines. MSHA gathers these data in accordance with Part 30 of the U.S. Code of Federal Regulations. To collect this

information, MSHA requires mines to submit a form (7000-1) that describes each "reportable" accident. Also, each working mine must submit quarterly information about their operations, including production, employee-hours, and mine characteristics on another standard form

(7000-2). The USBM has access to computerized copies of this information for all mine operators from 1975 through 1991. The USBM does not have access to computerized data about independent contractors. Independent contractor employees have become a more significant part of the mining work force in the past decade. They may perform a wide variety of support functions for mine operators, such as hauling coal or constructing various facilities on mine property. Consequently, the numbers presented here will be slightly smaller than analyses that include independent contractors. Also, reporting requirements for contractors are somewhat different from those for operators, so the data are not readily comparable.

The analyses presented here primarily cover the years 1989 through 1991. At this writing, the 1991 data are the most recent available in the USBM's copy of the MSHA database. A limitation of the MSHA data is that not all of the information on the reporting forms is complete for all the mines in the database. For instance, information on employment, production, and other variables is sometimes missing. A total of 2,187 mines met the selection criteria of reporting nonzero underground production, or reporting a fatality during at least 1 of the 3 years studied. (That is, mines that reported zero coal production were included in the analyses only if a fatality had occurred at that location.)

The injury data analyses will focus on three types of injuries: (1) fatalities (MSHA "Degree of Injury" code 1), (2) permanently disabling injuries (MSHA "Degree of Injury" code 2), and (3) lost-time injuries that caused the employee to miss more than 20 days of work (referred to as serious injuries).

Throughout the tables of statistics presented in this paper, mines have been stratified according to their size.

Mines were usually put into one of the following four size categories based on the average number of employees at that operation: 1 to 20, 21 to 50, 51 to 100, and more than 100. Both the number of employees and the number of employee-hours included people who worked (1) underground, (2) at the surface of underground mines (except office workers), and (3) in preparation plants at underground mines. The size of each mine was usually determined by averaging the annual number of employees reported by the mine for 1989, 1990, and 1991. However, there were a couple of exceptions to this procedure: (1) All data pertaining to office workers were excluded from the analyses because these workers are not normally exposed to the types of hazards that other mine employees face; (2) mines where a fatality had occurred were placed into the mine size category that corresponded to the average number of employees the mine reported *for the year of the fatality* as opposed to using the 3-year average. This was done to accurately characterize what mines were like at the time the fatal accident occurred and also to be consistent with MSHA's statistics for the number of fatalities occurring in mines of a particular size category.

The NAS researchers considered mines of 50 or fewer employees to be "small" mines. This paper follows the same convention—the term "small mines" always refers to mines of 50 or fewer employees. However, close to half of U.S. underground coal mines employ 20 or fewer people. Because so many mines are in this category, statistics are always reported for each of two separate categories of small mines: mines of 20 or fewer employees and mines that employ between 20 and 50. Throughout this paper, mines that employ 20 or fewer people are always referred to as "very small" mines, and mines that employ more than 50 people are considered to be "large" mines.

## FINDINGS

The findings are organized into 10 tables of statistics. Each table is discussed below, beginning with a look at the number of mines in each size category that are located in each State.

### LOCATION OF MINES

Table 1 breaks down the total number of underground coal mines that reported any coal production during 1989-91 by State and mine size. Over half of the underground coal mines in operation during this time period were concentrated in the States of Kentucky and West Virginia, with 38.6% and 28.4% of the total number of mines, respectively. Virginia accounted for 15.4% of the mines, followed by Pennsylvania with 8.3%. Similarly, the majority of very small mines are concentrated in these States as

well. Of the 1,217 mines in this size category, 507 (41.7%) are located in Kentucky, 298 (24.5%) in West Virginia, 206 in Virginia, 120 in Pennsylvania, and 53 in Tennessee.

### UNDERGROUND COAL PRODUCTION

The total amount of coal produced from underground mines during 1989-91 is broken down by State and mine size in table 2. West Virginia mines produced 29.1% of the underground coal mined in the United States, followed by Kentucky mines with 24.4%. Other major producers of underground coal include Illinois (10.5%), Pennsylvania (10.1%), and Virginia (8.9%). Most of this production (60.3%) was from mines employing over 100 employees. Very small mines accounted for 8.5% of total underground coal production, and mines employing from 21 to 50



employees accounted for 20.2%. Of the coal produced by very small mines, 40% came from Kentucky, 30% from West Virginia, 20% from Virginia, 3.8% from Pennsylvania, and 2.7% from Tennessee.

**Table 1.—Number of underground coal mines stratified by State and mine size (number of employees) in 1989-91**

| State                        | Number of employees |          |           |          | Total | % of U.S. total |
|------------------------------|---------------------|----------|-----------|----------|-------|-----------------|
|                              | 1 to 20             | 21 to 50 | 51 to 100 | Over 100 |       |                 |
| Alabama . . . . .            | 6                   | 1        | 1         | 9        | 17    | 0.8             |
| Colorado . . . . .           | 6                   | 3        | 3         | 5        | 17    | 0.8             |
| Illinois . . . . .           | 2                   | 4        | 2         | 23       | 31    | 1.4             |
| Kentucky . . . . .           | 507                 | 262      | 41        | 34       | 844   | 38.6            |
| Ohio . . . . .               | 8                   | 3        | 1         | 7        | 19    | 0.9             |
| Pennsylvania . .             | 120                 | 23       | 16        | 23       | 182   | 8.3             |
| Tennessee . . . .            | 53                  | 23       | 3         | 1        | 80    | 3.7             |
| Utah . . . . .               | 5                   | 2        | 7         | 8        | 22    | 1.0             |
| Virginia . . . . .           | 206                 | 102      | 20        | 9        | 337   | 15.4            |
| West Virginia . .            | 298                 | 256      | 27        | 41       | 622   | 28.4            |
| Other <sup>1</sup> . . . . . | 6                   | 4        | 4         | 2        | 16    | 0.7             |
| U.S. total . . . .           | 1,217               | 683      | 125       | 162      | 2,187 | NAp             |
| % of U.S. total . . . . .    | 55.6                | 31.2     | 5.7       | 7.4      | NAp   | 100             |

NAp Not applicable.

<sup>1</sup>Arkansas, Indiana, Iowa, Maryland, Montana, New Mexico, Oklahoma, and Wyoming.

**Table 2.—Total underground coal production<sup>1</sup> stratified by State and mine size (number of employees) in 1989-91**

| State                        | Number of employees |          |           |          | Total    | % of U.S. total |
|------------------------------|---------------------|----------|-----------|----------|----------|-----------------|
|                              | 1 to 20             | 21 to 50 | 51 to 100 | Over 100 |          |                 |
| Alabama . . . . .            | 0.06                | 0.01     | 0.33      | 43.44    | 43.83    | 4.0             |
| Colorado . . . . .           | 0.76                | 2.03     | 4.44      | 17.70    | 24.92    | 2.3             |
| Illinois . . . . .           | 0.06                | 1.88     | 4.04      | 109.75   | 115.70   | 10.5            |
| Kentucky . . . . .           | 37.30               | 79.89    | 41.71     | 108.98   | 267.88   | 24.4            |
| Ohio . . . . .               | 0.93                | 1.71     | 0.23      | 29.75    | 32.61    | 3.0             |
| Pennsylvania . .             | 3.57                | 9.24     | 13.09     | 85.26    | 111.16   | 10.1            |
| Tennessee . . . .            | 2.56                | 4.37     | 2.62      | 1.54     | 11.09    | 1.0             |
| Utah . . . . .               | 1.62                | 0.69     | 10.24     | 45.60    | 58.16    | 5.3             |
| Virginia . . . . .           | 18.34               | 30.51    | 15.49     | 33.82    | 98.16    | 8.9             |
| West Virginia . .            | 27.98               | 90.85    | 24.57     | 176.35   | 319.74   | 29.1            |
| Other <sup>2</sup> . . . . . | 0.16                | 0.78     | 4.40      | 10.23    | 15.58    | 1.4             |
| U.S. total . . . .           | 93.37               | 221.94   | 121.14    | 662.38   | 1,098.83 | NAp             |
| % of U.S. total . . . . .    | 8.5                 | 20.2     | 11.0      | 60.3     | NAp      | 100.0           |

NAp Not applicable.

<sup>1</sup>Production is in millions of metric tons. To convert to short tons, multiply by 1.10232.

<sup>2</sup>Arkansas, Indiana, Iowa, Maryland, Montana, New Mexico, Oklahoma, and Wyoming.

## CHANGES IN PRODUCTION, EMPLOYMENT, AND INJURY RATES DURING THE 1980's

Table 3 presents eight different measures of the U.S. underground coal mining industry stratified by mine size. To be able to see how the industry changed during the 1980's, statistics are presented that reflect two different periods: 1978-80 and 1989-91. Also included in the table is the percentage of change over the intervening 8-year span for each of the mine characteristics listed.

### 1978-80 Statistics

Several trends relating to mine size are evident for the period 1978-80. As mine size increases, the number of mines within each size category decreases and the number of employee-hours and the amount of production increases. The productivity rate, however, decreases with increasing mine size from 1.69 t/h at very small mines to 0.98 t/h at mines with 50 or more employees. Both the fatality rate and the permanent disability rate decrease with increasing mine size. However, the decrease in permanent disability rates (from 0.205 to 0.165 injuries per 200,000 h) is of a much lower magnitude than the decrease in fatality rates (from 0.245 to 0.062).

### 1989-91 Statistics

Trends similar to those observed for 1978-80 are evident for this period as well with one notable exception. The productivity rate is now highest for mines with 21 to 50 employees (2.69 t/h), followed by a productivity rate of 2.46 t/h for mines with 50 or more employees. It is the very small mines that now have the lowest productivity rate, 2.27 t/h.

### 1978-80 Versus 1989-91 Statistics

The last three columns in table 3 summarize the data aggregated across mine size for the two time periods and show the percentage of change from one time period to the next.

*Productivity.*—The most significant change is a 136% increase in overall productivity. This reflects a 42% increase in overall production and a 40% decrease in the overall number of employee-hours. Looking across mine size categories, the increase in production rate becomes more dramatic with increasing mine size, such that for mines with more than 50 employees the production rate has increased by 152%.

*Number of Mines and Amount of Production.*—The total number of mines in operation decreased by 32%. The

largest decrease (51%) was sustained by mines with 50 or more employees. Although the number of very small mines decreased by 39%, this category still constitutes over half (56%) of the total number of mines in operation. Conversely, the number of mines with 21 to 50 employees has increased by 8% from 631 mines in 1978-80 to 683 mines in operation during 1989-91. Similarly, this mine size category, in contrast to the larger and smaller mine sizes, shows a substantial increase in total production and number of employee-hours. Production at mines with 21 to 50 employees has increased 155% compared with an increase of only 21% and 29% for very small and large mines, respectively.

*Fatalities and Disabling Injuries.*—During the 1980's, the overall fatality rate decreased by 26%. The percentage of decrease in fatality rates becomes more pronounced with increasing mine size. For mines with more than 50 employees, the fatality rate has been decreased by almost half (43%). For very small mines, the fatality rate has decreased by 29%. Conversely, the permanent disability rate increased for all three mine size categories during the 1980's. The increases ranged from 11% for the smallest mines to 30% for mines in the 21- to 50-employee category. Overall, the increase was 20%. This increase is somewhat unexpected, and the reasons for it are not clear.

## ACCIDENT TYPES

### Fatal Accidents<sup>4</sup>

Table 4 breaks down the total number of accidents that resulted in one or more fatalities during the period 1987-91 by type of accident and mine size. Because fatalities are a relatively rare event, a 5-year span was used for this table rather than a 3-year span. Increasing the number of incidents under consideration helps to minimize the impact of annual fluctuations. Overall, ground fall accidents constituted close to half (46.7%) of the total number of fatal accidents occurring over this 5-year period. The majority (72%) of the 85 fatal ground fall accidents occurred in mines with 50 or fewer employees. [See Randolph (7) for an analysis of how ground fall accident rates vary according to mine size and various other factors. For some ideas about how to prevent roof fall accidents at small mines, see USBM Information Circular 9332 (10).]

<sup>4</sup>It is important to note that the accident statistics in tables 4 and 5 do not reflect fatalities experienced by independent contractors. If independent contractor fatalities were included, the trends might appear different. For example, powered haulage accidents are one of the most common causes of fatalities to independent contractors, but ground falls are not.

**Table 3.—Number of operations, employee hours, production, and rates of fatalities and permanently disabling injuries during two 3-year periods stratified by mine size (number of employees)**

|  | Number of employees |         |          |          |         |          |         |         |          | Total or overall rate |          |          |
|--|---------------------|---------|----------|----------|---------|----------|---------|---------|----------|-----------------------|----------|----------|
|  | 1 to 20             |         |          | 21 to 50 |         |          | Over 50 |         |          |                       |          |          |
|  | 1978-80             | 1989-91 | % change | 1978-80  | 1989-91 | % change | 1978-80 | 1989-91 | % change | 1978-80               | 1989-91  | % change |
| Number of operations . . . . .                   | 1,995               | 1,217   | -39      | 631      | 683     | +8       | 585     | 287     | -51      | 3,211                 | 2,187    | -32      |
| Employee-hours <sup>1</sup> . . . . .            | 45.76               | 41.20   | -10      | 64.80    | 82.38   | +27      | 622.23  | 318.85  | -49      | 732.79                | 442.43   | -40      |
| Production <sup>2</sup> . . . . .                | 77.09               | 93.37   | +21      | 87.18    | 221.94  | +155     | 607.32  | 783.51  | +29      | 771.58                | 1,098.82 | +42      |
| Productivity <sup>3</sup> . . . . .              | 1.69                | 2.27    | +35      | 1.34     | 2.69    | +100     | 0.98    | 2.46    | +152     | 1.05                  | 2.49     | +136     |
| Fatalities . . . . .                             | 56                  | 36      | -36      | 48       | 40      | -17      | 193     | 56      | -71      | 297                   | 132      | -56      |
| Fatality rate <sup>4</sup> . . . . .             | 0.245               | 0.175   | -29      | 0.148    | 0.097   | -34      | 0.062   | 0.035   | -43      | 0.081                 | 0.060    | -26      |
| Permanent disabilities <sup>5</sup> . . . . .    | 47                  | 47      | 0        | 55       | 91      | +65      | 512     | 305     | -40      | 614                   | 443      | -28      |
| Permanent disability rate <sup>4</sup> . . . . . | 0.205               | 0.228   | +11      | 0.170    | 0.221   | +30      | 0.165   | 0.191   | +16      | 0.168                 | 0.200    | +20      |

<sup>1</sup>Employee-hours are in millions of hours.

<sup>2</sup>Production is in millions of metric tons. To convert to short tons, multiply by 1.10232.

<sup>3</sup>Number of metric tons per employee-hour.

<sup>4</sup>Per 200,000 employee-hours of exposure.

<sup>5</sup>Includes all total and partial permanently disabling injuries except inguinal hernias that are repaired and losses of teeth or the tips of toes and fingers.

**Table 4.—Number of accidents resulting in one or more fatalities at an underground coal mine stratified by type of accident and mine size (number of employees) in 1987-91**

| Accident type         | Number of employees |          |           |          | Total | % of total |
|-----------------------|---------------------|----------|-----------|----------|-------|------------|
|                       | 1 to 20             | 21 to 50 | 51 to 100 | Over 100 |       |            |
| Ground fall . . . . . | 33                  | 28       | 6         | 18       | 85    | 46.7       |
| Powered haulage . . . | 7                   | 11       | 5         | 14       | 37    | 20.3       |
| Machinery . . . . .   | 1                   | 7        | 4         | 11       | 23    | 12.6       |
| Electrical . . . . .  | 5                   | 3        | 3         | 6        | 17    | 9.3        |
| Explosives . . . . .  | 3                   | 1        | 1         | 0        | 5     | 2.7        |
| Other . . . . .       | 5                   | 4        | 0         | 6        | 15    | 8.2        |
| Total . . . . .       | 54                  | 54       | 19        | 55       | 182   | NAp        |
| % of total . . . . .  | 29.7                | 29.7     | 10.4      | 30.2     | NAp   | 100        |

NAp Not applicable.

The next most frequent type of fatal mining accidents are those associated with powered haulage equipment. MSHA's accident classification scheme considers powered haulage accidents to be those that are ". . . caused by the motion of the haulage unit, e.g., motors and rail cars, conveyors, shuttle cars, haulage trucks, front-end loaders, etc. Also includes any accidents caused by a moving part of the haulage unit." Fatal powered haulage accidents are almost evenly split between mines with over 50 employees versus mines with 50 or fewer employees. Further statistics on powered haulage accidents may be found in the Holmes Safety Association Bulletin (4).

Of the 182 accidents causing 1 or more fatalities, 54 occurred at mines with 1 to 20 employees, another 54 occurred at mines with 21 to 50 employees, 19 occurred at mines with 51 to 100 employees, and 55 occurred at mines employing over 100 people. Thus, a sizeable number of fatal accidents have occurred at *both* large and small underground coal mines.

It is interesting to note that the NAS (5) researchers found that the distribution of types of accidents causing fatalities did NOT vary much across mine size. They conclude that—

This indicates that the larger fatality rate in small mines is not the result of an increase in a specific type of accident (e.g., roof falls). Rather, the data indicated that smaller mines are more likely than larger mines to have fatalities from each of the major types of accidents. This would suggest that the problem in small mines is not isolated to a specific work activity (such as roof bolting), but is present in all aspects of the mining effort.

Based on analysis of more recent data, this conclusion no longer appears true. Table 5 shows rates of fatal accidents stratified by accident type and mine size during 1987-91. In comparing the rate of various types of accidents at mines of 20 or fewer employees versus mines of 50 and over, one sees that the rate of fatalities is greater at very small mines for each major accident type (except

machinery). This is in line with what the NAS researchers found. However, looking down the last column of table 5, one sees that the magnitude of the difference between rates of various types of fatal accidents at very small versus large mines varies quite a bit from one type of accident to the next. In particular, the rate of fatal ground fall accidents is 10.7 times greater at very small mines than it is at mines with over 50 employees. The corresponding ratios for fatal powered haulage, machinery, and electrical accidents are 2.9, 0.5, and 4.4, respectively. Thus, there is a much bigger disparity between fatal ground fall accident rates at very small versus large mines than there is for rates of other types of fatal accidents.

**Table 5.—Rates<sup>1</sup> of fatal accidents stratified by accident type and mine size (number of employees) in 1987-91**

| Accident type           | Mine size |          |         | Ratio <sup>2</sup> |
|-------------------------|-----------|----------|---------|--------------------|
|                         | 1 to 20   | 21 to 50 | Over 50 |                    |
| Ground fall . . . . .   | 0.0965    | 0.0418   | 0.0089  | 10.8               |
| Electrical . . . . .    | 0.0146    | 0.0045   | 0.0033  | 4.4                |
| Machinery . . . . .     | 0.0029    | 0.0104   | 0.0056  | 0.5                |
| Powered haulage . . . . | 0.0205    | 0.0164   | 0.0071  | 2.9                |

<sup>1</sup>Per 200,000 employee-hours of exposure.

<sup>2</sup>Ratio of rate for 1 to 20 employees to rate of over 50 employees.

### Serious Injuries

Table 6 breaks down the total number of serious injuries during 1989-91 by type of accident and mine size. In this table, serious injuries are considered to be any nonfatal injury that caused a permanent disability or that resulted in more than 20 days of lost work. The last two columns in table 6 list the numbers and rates of the various types of accidents that were reported by all the mines over this 3-year period. Overall, "handling material" accidents occurred at the highest rate (1.97), accounting for 36.4% of all serious injuries. The next highest rate was for "slip or fall" accidents (0.89), which accounted for 16.4% of all serious injuries. Together, these two accident types accounted for over half of the serious injuries reported over this 3-year period. For some ideas about how to prevent handling material accidents in coal mines, see Unger (9), Gallagher (2), Conway (1), and Hamrick (3).

A few trends are evident when looking at variations in the rate of specific types of accidents across mine size categories. It appears that rates of serious handling material accidents increase as mines get bigger. The rate of handling material accidents ranges from 1.42 at very small mines to 2.05 for mines with over 100 employees. Whereas handling material accidents account for 28% of all serious injuries at very small mines, they account for 38% of all serious injuries at mines of over 100 employees. Similarly, the trend is for serious injuries caused by slips or falls to occur at a higher rate as mine size increases. At mines of over 100 employees, the rate is over twice as high as at very small mines (1.11 versus 0.47).

Table 6.—Number and rates<sup>1</sup> of serious injuries<sup>2</sup> stratified by accident type and mine size (number of employees) in 1989-91

| Accident type                  | Number of employees |      |          |      |           |      |          |      | Total  | Overall rate |
|--------------------------------|---------------------|------|----------|------|-----------|------|----------|------|--------|--------------|
|                                | 1 to 20             |      | 21 to 50 |      | 51 to 100 |      | Over 100 |      |        |              |
|                                | Injuries            | Rate | Injuries | Rate | Injuries  | Rate | Injuries | Rate |        |              |
| Handling material . . . . .    | 292                 | 1.42 | 805      | 1.95 | 478       | 2.03 | 2,787    | 2.05 | 4,362  | 1.97         |
| Slip or fall . . . . .         | 96                  | 0.47 | 230      | 0.56 | 140       | 0.60 | 1,502    | 1.11 | 1,968  | 0.89         |
| Machinery . . . . .            | 211                 | 1.02 | 422      | 1.02 | 207       | 0.88 | 782      | 0.58 | 1,622  | 0.73         |
| Powered haulage . . . . .      | 227                 | 1.10 | 427      | 1.04 | 178       | 0.76 | 746      | 0.55 | 1,578  | 0.71         |
| Ground fall . . . . .          | 97                  | 0.47 | 220      | 0.53 | 92        | 0.39 | 493      | 0.36 | 902    | 0.41         |
| Hand tool . . . . .            | 51                  | 0.25 | 91       | 0.22 | 64        | 0.27 | 462      | 0.34 | 668    | 0.30         |
| Stepping or kneeling . . . . . | 20                  | 0.10 | 49       | 0.12 | 28        | 0.12 | 153      | 0.11 | 250    | 0.11         |
| Striking or bumping . . . . .  | 7                   | 0.03 | 10       | 0.02 | 5         | 0.02 | 132      | 0.10 | 154    | 0.07         |
| Electrical . . . . .           | 9                   | 0.04 | 30       | 0.07 | 14        | 0.06 | 43       | 0.03 | 96     | 0.04         |
| Other <sup>2</sup> . . . . .   | 29                  | 0.14 | 53       | 0.13 | 38        | 0.16 | 271      | 0.20 | 391    | 0.18         |
| Total . . . . .                | 1,039               | 5.04 | 2,337    | 5.67 | 1,244     | 5.29 | 7,371    | 5.42 | 11,991 | 5.42         |

<sup>1</sup>Per 200,000 employee-hours of exposure.

<sup>2</sup>Serious injuries include those classified as permanently disabling and those that caused the employee to miss more than 20 days of work.

Machinery accidents are the third most common type of accident resulting in serious injuries. They account for 13.5% of the total and occur at a rate of 0.73. Powered haulage accidents, with a rate of 0.71, account for 13.2% of the serious injuries reported by underground coal mines. In contrast to the previously noted trends across mine size categories, the trend is for serious powered haulage and machinery accidents to occur at successively lower rates as mine size increases. From the smallest to the largest mine size category, the rates for both categories of accidents decrease by about half.

Other differences relative to mine size include a slight decrease in the rate of serious ground fall accidents with increasing mine size (from 0.47 to 0.36), and a slight increase in the rate of serious hand tool accidents with increasing mine size (from 0.25 to 0.34).

#### FATALITY AND INJURY RATES FOR SELECTED STATES

Table 7 displays rates of fatalities, permanent disabilities, and serious injuries (injuries resulting in more than 20 lost workdays), stratified by State and mine size for 1989-91. The table is limited to only those States with at least 50 very small underground mines. The "overall" rates listed at the bottom of the table, however, include fatalities and injuries in underground coal mines from all States. Data are not given for Tennessee mines in the two largest size categories because of the extremely small number of large mines in Tennessee.

**Fatality Rates.**—As noted previously, looking across mine size categories, the overall fatality rate is highest for mines with 20 or fewer employees, then drops suddenly by almost half for mines with 21 to 50 employees, and drops by half again for mines with more than 50 employees. For the most part, this trend of decreasing fatality rates with increasing mine size is evident within each of the five States.

The major exception to this overall pattern occurs in Virginia where the fatality rate for mines with 21 to 50 employees is slightly higher than that for the smaller mines. The last column in table 7 shows the overall fatality rates for each of the five States. They range from 0.015 for Pennsylvania to 0.114 for Kentucky. Of the five States, West Virginia and Kentucky have the highest fatality rates for very small mines, 0.223 and 0.180, respectively. It is interesting that these also happen to be the two States with the largest number of small mines.

**Permanent Disability Rates.**—The trends observed in fatality rates relative to mine size are not as clear and pronounced in the permanent disability rates. For example, although the overall fatality rate for very small mines (0.175) is five times as great as the fatality rate for very large mines (0.033), the overall permanent disability rate for very small mines (0.228) is only 1.2 times as great as that for the largest mines (0.183). Mines in the 51- to 100-employee category actually have the highest overall rate of permanent disabilities (0.238).

**Serious Injury Rates.**—Again, the clear trend that was observed in fatality rates relative to mine size is not present in the overall serious injury rates. The overall serious injury rates for very small mines (4.82) is actually less than that for the largest mines (5.24).

**Other Trends.**—Looking down the last column at the overall rates across States, one sees that the three measures of safety for Pennsylvania mines lead to conflicting conclusions. Although Pennsylvania had the lowest fatality rate among the five States, it had the second highest permanent disability rate (0.236) and the highest serious injury rate (6.81).

Looking across mine size categories within States, a few trends are apparent. In Pennsylvania, both the permanent disability and serious injury rates increase with increasing mine size, a twofold to threefold increase from the smallest to the largest mine size category. Conversely,

in Virginia, the serious injury rate decreases with increasing mine size, from 6.43 to 5.03, a 22% decrease from the smallest to the largest mine sizes.

**Table 7.—Rates<sup>1</sup> of fatalities, permanent disabilities, and serious injuries<sup>2</sup> stratified by State and mine size (number of employees) in 1989-91**

| State and rate           | Number of employees |          |           |          | Overall rate |
|--------------------------|---------------------|----------|-----------|----------|--------------|
|                          | 1 to 20             | 21 to 50 | 51 to 100 | Over 100 |              |
| <b>Kentucky:</b>         |                     |          |           |          |              |
| Fatality . . . . .       | 0.180               | 0.100    | 0.094     | 0.105    | 0.114        |
| Permanent disability     | 0.252               | 0.288    | 0.216     | 0.177    | 0.227        |
| Serious injury . . . . . | 4.36                | 5.36     | 4.97      | 4.50     | 4.79         |
| <b>Pennsylvania:</b>     |                     |          |           |          |              |
| Fatality . . . . .       | 0.156               | 0.000    | 0.000     | 0.010    | 0.015        |
| Permanent disability     | 0.078               | 0.155    | 0.199     | 0.259    | 0.236        |
| Serious injury . . . . . | 3.05                | 4.82     | 6.46      | 7.30     | 6.81         |
| <b>Tennessee:</b>        |                     |          |           |          |              |
| Fatality . . . . .       | 0.112               | 0.073    | Neg.      | Neg.     | 0.058        |
| Permanent disability     | 0.224               | 0.366    | Neg.      | Neg.     | 0.259        |
| Serious injury . . . . . | 4.60                | 4.46     | Neg.      | Neg.     | 3.97         |
| <b>Virginia:</b>         |                     |          |           |          |              |
| Fatality . . . . .       | 0.122               | 0.166    | 0.050     | 0.013    | 0.084        |
| Permanent disability     | 0.171               | 0.181    | 0.250     | 0.139    | 0.177        |
| Serious injury . . . . . | 6.43                | 5.89     | 5.85      | 5.03     | 5.68         |
| <b>West Virginia:</b>    |                     |          |           |          |              |
| Fatality . . . . .       | 0.223               | 0.066    | 0.021     | 0.015    | 0.047        |
| Permanent disability     | 0.241               | 0.173    | 0.338     | 0.146    | 0.176        |
| Serious injury . . . . . | 4.88                | 5.65     | 5.04      | 4.66     | 4.96         |
| <b>Total:</b>            |                     |          |           |          |              |
| Fatality . . . . .       | 0.175               | 0.097    | 0.047     | 0.033    | 0.060        |
| Permanent disability     | 0.228               | 0.221    | 0.238     | 0.183    | 0.200        |
| Serious injury . . . . . | 4.82                | 5.45     | 5.05      | 5.24     | 5.22         |

Neg. Negligible. Data are not reported because the number of mining operations in this category was extremely small.

<sup>1</sup>Per 200,000 employee-hours of exposure.

<sup>2</sup>Injuries, other than those classified as permanently disabling, which caused the employee to miss more than 20 days of work.

## EMPLOYEE-HOURS AND PRODUCTIVITY

Table 8 displays total employee-hours and productivity during 1989-91 for each of the five States where the majority of small mines are located, broken down by mine size. Across the five States, productivity ranges from 1.60 t/h for Tennessee to 2.69 t/h for West Virginia. Across the different categories of mine size, productivity ranges from 2.27 t/h for very small mines to 2.69 t/h for mines with 21 to 50 employees.

## CHARACTERISTICS OF SERIOUSLY INJURED MINERS

Table 9 displays the mean age of seriously injured miners during 1989-91, as well as the number of years of experience they had (1) working at their current mine, (2) working in their current job classification, and

(3) working as a coal miner. The overall means as well as the means for four mine size categories are presented. The means for each of the four victim characteristics steadily increases as mine size increases. The mean for "experience at mine" displays the most dramatic increase, from 1.95 for very small mines to 11.0 for mines with over 100 employees. This may largely reflect the fact that most small mines do not remain open for nearly as long as large mines. It may also reflect a tendency for younger, less experienced miners to be hired by small mines rather than large mines, and that when larger mines have had to lay off workers during the 1980's, it was the younger miners who lost their jobs.

**Table 8.—Total employee hours<sup>1</sup> and productivity<sup>2</sup> stratified by State and by mine size (number of employees) in 1989-91**

| State and variable            | Number of employees |          |           |          | Total or overall rate |
|-------------------------------|---------------------|----------|-----------|----------|-----------------------|
|                               | 1 to 20             | 21 to 50 | 51 to 100 | Over 100 |                       |
| <b>Kentucky:</b>              |                     |          |           |          |                       |
| Employee-hours                | 16.646              | 29.876   | 14.835    | 41.926   | 103.282               |
| Productivity . . .            | 2.24                | 2.68     | 2.81      | 2.60     | 2.59                  |
| <b>Pennsylvania:</b>          |                     |          |           |          |                       |
| Employee-hours                | 2.557               | 3.860    | 6.041     | 39.344   | 51.803                |
| Productivity . . .            | 1.40                | 2.39     | 2.17      | 2.17     | 2.15                  |
| <b>Tennessee:</b>             |                     |          |           |          |                       |
| Employee-hours                | 1.782               | 2.734    | 1.254     | 1.177    | 6.946                 |
| Productivity . . .            | 1.43                | 1.60     | Neg.      | Neg.     | 1.60                  |
| <b>Virginia:</b>              |                     |          |           |          |                       |
| Employee-hours                | 8.211               | 13.274   | 8.006     | 15.826   | 45.317                |
| Productivity . . .            | 2.23                | 2.30     | 1.93      | 2.14     | 2.17                  |
| <b>West Virginia:</b>         |                     |          |           |          |                       |
| Employee-hours                | 10.787              | 30.113   | 9.479     | 68.617   | 118.996               |
| Productivity . . .            | 2.59                | 3.02     | 2.59      | 2.56     | 2.69                  |
| <b>Total or overall rate:</b> |                     |          |           |          |                       |
| Employee-hours                | 41.203              | 82.383   | 47.025    | 271.820  | 442.431               |
| Productivity . . .            | 2.27                | 2.69     | 2.58      | 2.44     | 2.49                  |

Neg. Negligible. Data are not reported because the number of mining operations in this category was extremely small.

<sup>1</sup>Hours are in millions.

<sup>2</sup>Number of metric tons per employee-hour.

**Table 9.—Mean age and experience of seriously injured<sup>1</sup> miners stratified by mine size (number of employees) in 1989-91**

| Victim characteristic       | Number of employees |          |           |          | Overall |
|-----------------------------|---------------------|----------|-----------|----------|---------|
|                             | 1 to 20             | 21 to 50 | 51 to 100 | Over 100 |         |
| Age . . . . .               | 32.3                | 34.0     | 36.7      | 40.3     | 38.0    |
| Experience at mine . . .    | 1.95                | 2.6      | 5.3       | 11.0     | 8.0     |
| Experience in job . . . . . | 5.6                 | 5.8      | 6.0       | 6.7      | 6.1     |
| Total mining experience     | 12.1                | 13.0     | 13.4      | 14.9     | 14.2    |

<sup>1</sup>Serious injuries include those classified as permanently disabling and those that caused the employee to miss more than 20 days of work.

It is interesting to note that the age distribution of miners at various sizes of mines appears to have changed since the NAS (6) study was conducted. The NAS researchers reported finding no age differences relative to mine size. However, the present data show a difference of 8 years between the average age of injured miners at small mines (32.3) versus large mines (40.3). (A note of caution: One must keep in mind that the ages of injured miners may not necessarily correspond to the ages of all miners in the work force.)

### MINE-LEVEL DESCRIPTIVE STATISTICS

Data on mining accidents, employment, and production can be aggregated or grouped at various levels of analysis. Throughout the tables of statistics discussed thus far, the data have NOT been based on mine-level analyses. The data from all mines that fell within a specified size category were aggregated or pooled together in the calculation of statistics. For instance, accident rates have been calculated by adding together all the accidents that occurred throughout all the mines in a particular size category, dividing this number by the sum of all the employee-hours worked throughout those same mines and then multiplying by 200,000.

However, in table 10 the statistics are based on data aggregated at the mine level of analysis. In this procedure, the first step is to calculate an accident rate for each mine. The mean accident rate for mines in a particular size category is then computed by finding the average of the rates for each of the mines in that size category. An important feature of using the mine level of analysis is that each mine is treated as a single data point and given the same weight as any other mine. An advantage of this procedure is that it allows one to see the variation that exists among the mines in a particular size category. Table 10 presents mine-level descriptive statistics for productivity, seam height, and rate of serious and fatal accidents during 1989-91.

**Productivity.**—Statistics are reported for all underground coal mines as well as for each of four mine size categories. The differences in the figures for mean mine-level productivity between different mine size categories correspond fairly closely to what was reported in table 3. The smallest mines have the lowest mean productivity rate (2.07), and mines in the 21- to 50-employee category have the highest productivity (2.66).

**Seam Height.**—As was reported in the NAS (5) study, there is still a clear trend toward larger mines operating in higher coal seams. The overall median seam height is 109 cm (43 in). The median for the category of very small mines is 102 cm (40 in). As mine size increases, the

median seam height steadily increases, such that mines with over 100 employees have a median seam height of 168 cm (66 in).

**Rate of Fatalities and Serious Injuries.**—Looking at the mean and median rate of fatalities and serious injuries across mine size categories, there appear to be no clear trends. However, the standard deviations (std dev) show a decreasing trend with increasing mine size. The difference between the largest mines (std dev = 3.16) and the smallest mines (std dev = 17.10) is particularly dramatic and is further reflected in the differences between the medians for these two categories. The median of 0.00 for mines with 20 or fewer employees indicates that at least 50% of the mines in this size category reported zero serious injuries or fatalities for the period 1989-91 even though the average number of such incidents reported for these small mines is almost 6.

In contrast, for mines with more than 100 employees, at least 50% of these mines reported almost 5 fatalities or serious injuries and the average number reported is 5.71. With regard to this particular characteristic, smaller mines look very different from one another relative to the homogeneity exhibited by larger mines.

**Table 10.—Mine-level descriptive statistics for productivity, seam height, and rate of fatalities and serious injuries<sup>1</sup> stratified by mine size (number of employees) in 1989-91**

| Mine characteristic and rate                                | Number of employees |             |             |             | Overall     |
|---|---------------------|-------------|-------------|-------------|-------------|
|   | 1 to 20             | 21 to 50    | 51 to 100   | Over 100    |             |
| <b>Productivity:<sup>2</sup></b>                            |                     |             |             |             |             |
| Median  | 1.92                | 2.46        | 2.54        | 2.30        | 2.15        |
| Mean  | 2.07                | 2.66        | 2.60        | 2.49        | 2.31        |
| Std dev   | 1.34                | 1.24        | 1.05        | 1.07        | 1.31        |
| <b>Seam height:<sup>3</sup></b>                             |                     |             |             |             |             |
| Median  | 102<br>(40)         | 117<br>(46) | 135<br>(53) | 168<br>(66) | 109<br>(43) |
| Mean  | 112<br>(44)         | 127<br>(50) | 145<br>(57) | 180<br>(71) | 124<br>(49) |
| Std dev   | 43<br>(17)          | 46<br>(18)  | 46<br>(18)  | 53<br>(21)  | 51<br>(20)  |
| <b>Rate of fatalities and serious injuries:<sup>4</sup></b> |                     |             |             |             |             |
| Median  | 0.00                | 4.82        | 4.69        | 4.92        | 3.21        |
| Mean  | 5.57                | 6.20        | 5.25        | 5.71        | 5.76        |
| Std dev   | 17.10               | 6.30        | 3.24        | 3.16        | 13.28       |

Std dev Standard deviation.

<sup>1</sup>Serious injuries include those classified as permanently disabling and those that caused the employee to miss more than 20 days of work.

<sup>2</sup>Number of metric tons per employee-hour.

<sup>3</sup>Centimeters (numbers in parentheses are in inches). The U.S. mining industry refers to seam height in terms of inches.

<sup>4</sup>Per 200,000 employee-hours of exposure.

## SUMMARY AND CONCLUSIONS

It was found that fatality rates decline substantially as mine size increases. The fatality rate is 0.175 deaths per 200,000 h for mines with 20 or fewer employees. The rate drops by almost half for mines with 21 to 50 employees, and drops by half again for mines with more than 50 employees. Likewise, rates of permanently disabling injuries decline as mine size increases. However, there is no clear-cut trend in the relationship of mine size to the rate of other types of serious accidents—ones that cause the employee to miss more than 20 days of work. The rate of serious accidents is lowest for mines that employ 1 to 20 employees, highest among mines that employ 21 to 50 people, and intermediate for mines that employ more than 50 people.

Fatality rates are currently substantially lower than they were in the late 1970's. Although fatality rates decreased

during the 1980's for each mine size category, the percentage of decrease was lowest among the smallest size mines and highest among the largest size mines. In looking at the differences between rates of various types of fatal accidents at small versus large mines, it appears that ground fall accidents are a particularly important problem for small mines. The rate of fatal ground fall accidents is over 10 times greater at mines with 20 or fewer employees than it is at mines with over 50 employees.

Several trends become evident when looking at differences in the rates of specific categories of serious accidents across mine size categories (see table 6). In particular, the rates of accidents classified as "handling materials" and "slips or falls" increase with increasing mine size. Conversely, rates for accidents classified as "machinery" and "powered haulage" decrease with increasing mine size.

## REFERENCES

1. Conway, E. J., and R. L. Unger. Material Handling Devices for Underground Mines. BuMines IC 9212, 1989, 48 pp.
2. Gallagher, S., T. G. Bobick, and R. L. Unger. Reducing Back Injuries in Low-Coal Mines: Redesign of Materials-Handling Tasks. BuMines IC 9235, 1990, 33 pp.
3. Hamrick, C. A., and S. Gallagher. Job Design: An Effective Strategy for Reducing Back Injuries. Paper in this proceedings.
4. Holmes Safety Association Bulletin. Statistical Profile of Powered Haulage Accidents in the Mining Industry. Aug. 1993, pp. 16-17.
5. National Academy of Sciences. Fatalities in Small Underground Coal Mines (contract J0100145). BuMines OFR 124-83, 1983, 20 pp.
6. National Research Council (NAS). Toward Safer Underground Coal Mines. 1982, 190 pp.
7. Randolph, R. F. A Statistical Profile of Groundfall Injuries. Paper in Preventing Coal Mine Groundfall Accidents: How To Identify and Respond to Geologic Hazards and Prevent Unsafe Worker Behavior. BuMines IC 9332, 1992, pp. 79-89.
8. Tisdale, J. Meeting the Challenge of Serious Safety Problems at Small Coal Mines. Paper in Proceedings of the 24th Annual Institute on Coal Mine Safety Health and Research (Sept. 1, 1993). VA Polytech. Inst., Blacksburg, VA, pp. 115-126.
9. Unger, R. L. Mechanization of Materials Handling Tasks. Paper in Back Injuries. BuMines IC 8948, 1983, pp. 102-110.
10. U.S. Bureau of Mines. Preventing Coal Mine Groundfall Accidents: How To Identify and Respond to Geologic Hazards and Prevent Unsafe Worker Behavior. IC 9332, 1992, 89 pp.

# PILLAR DESIGN AND STRATEGIES FOR RETREAT MINING

By Frank E. Chase<sup>1</sup> and Christopher Mark<sup>2</sup>

## ABSTRACT

One of the keys to miner safety and an efficient recovery of the reserves is to design sufficiently sized production pillars that will prevent pillar squeezes, excessive pillar spalling, severe floor heave, roof falls, and pillar bumps. Currently, few mine operators design sections that will be retreat mined using empirical formulas or numerical models that estimate abutment pressures generated by adjacent mined-out workings. The U.S. Bureau of

Mines is in the process of field testing and refining a "user friendly" computer program called Analysis of Retreat Mining Pillar Stability (ARMPS) to estimate abutment pressures developed during pillaring. Analyses of 68 pillar design case histories using the ARMPS program indicate that it can be successfully employed to predict pillar line stability during retreat mining operations.

## INTRODUCTION

Use of remote-control miners, extended-cut waivers up to 12 m (40 ft), and mobile roof supports have enabled room-and-pillar retreat mining (also referred to as pillaring, robbing, and second mining) to be competitive with longwall mining. While longwall mining can claim an admirable safety record (12),<sup>3</sup> the same cannot be said of retreat mining. During the period between 1989 and 1993, 29% of the roof fall fatalities occurred on retreat mining sections. One of the most hazardous underground operations during retreat or any other type of mining is the removal of the push-out stump. Over a recent 10 year period, 10% of the fatalities resulting from roof or rib falls occurred during the removal of the push-out stump (11).

Roof fall accidents are not the only problem associated with retreat mining. Each year, considerable amounts of coal are lost because of squeezes, heave, pillar line roof falls, and pillar bumps. Yet few empirical formulas or numerical models are available that can estimate abutment pressures that develop when gob areas are created during pillar extraction. As part of its goal to reduce injuries and fatalities, the U.S. Bureau of Mines (USBM) is field testing and refining a method called Analysis of Retreat Mining Pillar Stability (ARMPS) to aid in the design of pillar retreat sections. This paper presents the findings thus far.

## ARMPS METHOD

The ARMPS formula is based on the Analysis of Longwall Pillar Stability (ALPS) method that is widely used for

longwall pillar design (8-9). The ALPS method was originally developed from measurements of abutment loads in five longwalls and later validated by back analysis of more than 100 longwall mining case histories. To be useful for pillar retreat mining, the ALPS method had to be modified for the different extraction geometries that are created during pillar extraction.

<sup>1</sup>Geologist.

<sup>2</sup>Mining engineer.

Pittsburgh Research Center, U.S. Bureau of Mines, Pittsburgh, PA.

<sup>3</sup>Italic numbers in parentheses refer to items in the list of references at the end of this paper.



The goal of the ARMPS method is to help ensure that the pillars developed for eventual extraction (production pillars) are of adequate size for all anticipated loading conditions. The most severe loadings usually develop on the extraction front (or pillar line), particularly where older gob areas from previously extracted panels are nearby. The ARMPS method determines a stability factor (SF) as—

$$SF = LBC/LT, \quad (1)$$

where LBC = estimated load-bearing capacity of pillars within active mining zone (AMZ)

and LT = estimated load applied to pillars within AMZ.

The AMZ is defined as being the width of the extraction front and three pillars deep (fig. 1).

Studies of longwall gate entries have indicated that three rows of pillars typically behave as a single system and that an SF calculated for the system as a whole is

more representative of conditions than an SF calculated for individual pillars.

The load-bearing capacity of the AMZ is calculated as the sum of the load-bearing capacities of the pillars within it. The strength of an individual pillar (SP) is determined using the Bieniawski formula (3):

$$SP = S_1 [0.64 + (0.36 w/h)], \quad (2)$$

where  $S_1$  = in situ coal strength [assumed value = 6.2 MPa (900 psi)],

w = pillar width,

and h = pillar height.

Longwall studies have indicated that 6.2 MPa (900 psi) is normally the appropriate value for  $S_1$  for use in this formula (8), and this value was used in all the case history analyses discussed. Current indications are that both coal strength and floor strength may be more important during pillar retreat than they are in longwall operations.

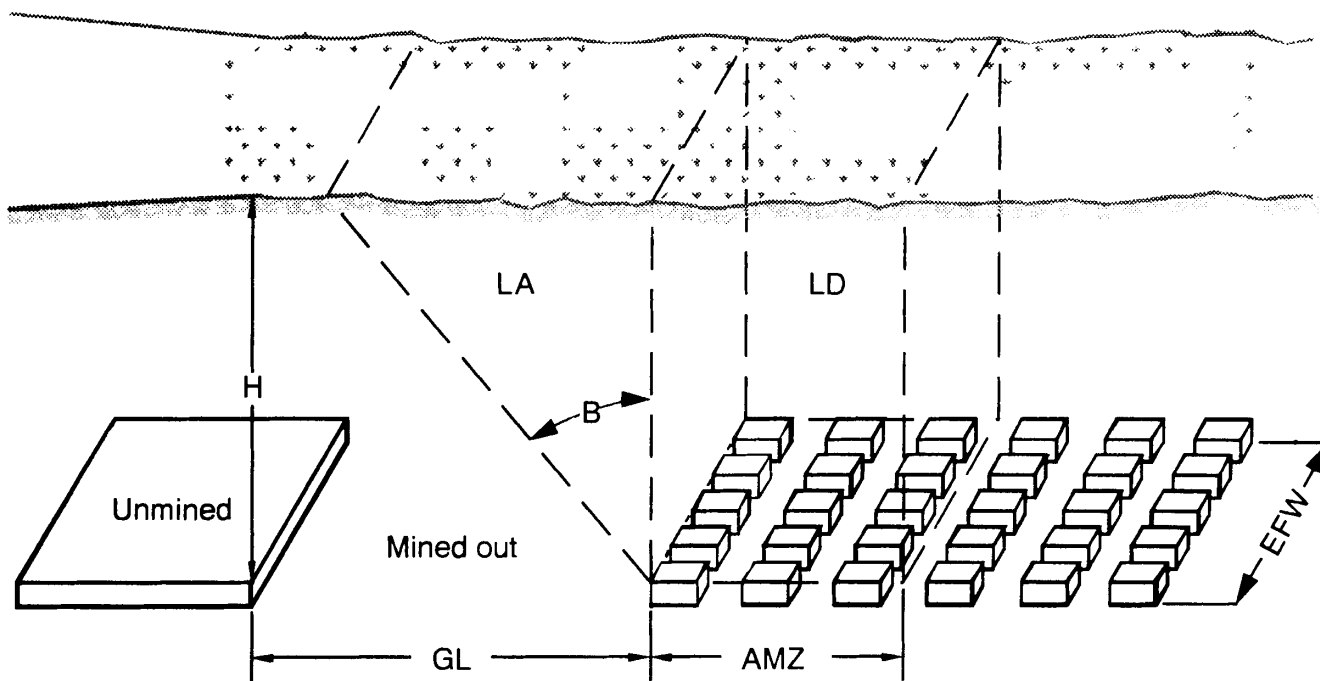

KEY

- |     |                        |    |                  |
|-----|------------------------|----|------------------|
| AMZ | Active mining zone     | H  | Depth of cover   |
| B   | Abutment angle         | LA | Abutment load    |
| EFW | Extraction front width | LD | Development load |
| GL  | Mined-out area         |    |                  |

Figure 1.—Schematic of active mining zone.

The loading applied to the AMZ (fig. 1) is the sum of—

- Development loading present before pillar retreat and
- Abutment loads created by load transfers from adjacent gobbed-out areas.

The development load (LD) is estimated using the tributary area formula—

$$LD = (H) (\gamma) (AT), \quad (3)$$

where  $H$  = depth of cover,

$\gamma$  = unit weight of overburden,

and  $AT$  = total area of AMZ.

Abutment loads (LA's) are determined using either equation 4 or equation 5, depending on the length of the mined-out area (GL):

When  $GL \geq 2 (H \tan B)$ ,

$$LA = H^2 (\tan B) (\gamma/2) (EFW), \quad (4)$$

and when  $GL < 2 (H \tan B)$ ,

$$LA = \left[ \frac{(H)(GL)}{2} - \frac{GL^2}{8 \tan B} \right] (\gamma) (EFW), \quad (5)$$

where  $B$  = abutment angle

and  $EFW$  = extraction front width.

The abutment angle value is dependent upon the caving conditions in the mined-out area. Three possible caving conditions have been found to occur. If good caving has developed in the gob areas and few stumps have been left, then the abutment angle is assumed to be the same as that used for longwall mining, or  $21^\circ$ . At the other extreme, if few stumps have been left, but caving has not occurred in the gob, then  $B = 90^\circ$ . A third case arises when caving has not occurred and significant remnant pillars (fenders or stumps) have been left in the gob. In the later case, it is assumed that the remnant pillars have yielded and their strength is assumed to be 50% of that calculated from equation 2. Then  $B$  is adjusted so that the remnant pillars carry only the load they are capable of and the remainder is transferred.

In its current form, the program can analyze four loading configurations, as illustrated in figure 2. The simplest—loading condition 1—is development loading only. Loading condition 2 occurs where a panel is being fully retreated and no other mined-out areas are nearby. The total applied load is the sum of the development loads and the front abutment load. Loading condition 3 occurs where the AMZ is surrounded on two sides by mined-out areas and the pillars are subjected to development, side abutment, and front abutment loads. When the pillar line is surrounded by gob on three sides (sometimes referred to as bottlenecking), an additional side-abutment load results and loading condition 4 is produced.

Unfortunately, the irregular mining geometries that sometimes occur in practice can be difficult to categorize into one of these four loading conditions. Efforts are currently underway to expand the number of available loading configurations with numerical modeling.

## VERIFICATION OF ARMPS METHOD

Design criteria have been established for the ARMPS method through back analysis of 68 case histories of pillar design from 10 different States. The case histories were obtained from mine visits and from the literature. Case histories cover an extensive range of geographic locations, roof rock cavability characteristics, extraction methods, and loading conditions. In addition, overburden thicknesses ranged from 53 to 591 m (175 to 1,938 ft), coalbed heights ranged from 0.9 to 3.4 m (2.8 to 11 ft), and pillar width-to-height ratios varied from 1.0 to 11.1.

Each case history was categorized as being either successful or unsuccessful. Unsuccessful cases (table 1) were deemed as being such because one or more of the following unfavorable conditions occurred:

1. Squeezes.
2. Massive pillar failure and resultant airblast.

3. Severe sloughage.
4. Excessive heave.
5. Numerous roof falls.
6. Coal pillar bump.

Case history loading conditions were categorized as being successful abutment loading, unsuccessful abutment loading, and unsuccessful development loading. Figure 3 clearly suggests that many failures, but few successes, have resulted when designs with ARMPS SF's of less than 0.75 were employed. Between SF's of 0.75 and 1.50, there seems to be a "middle ground," where both successful and unsuccessful cases are found. Based on figure 3, failure is unlikely when an ARMPS SF of 1.5 is employed. Bieniawski also recommends an SF of 1.5 for short-term pillars subjected to development loads only (3).

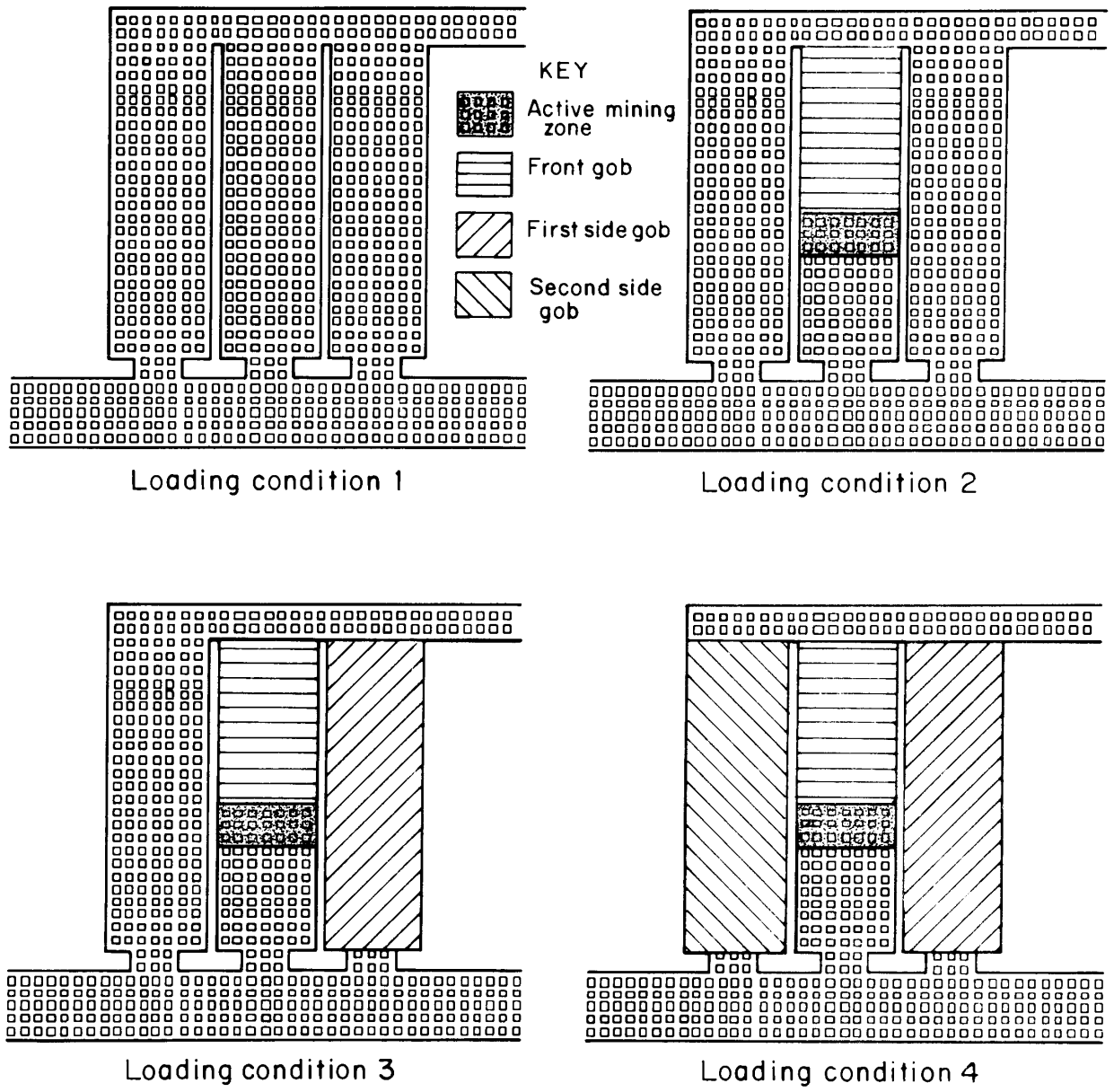

Figure 2.—Retreat mining loading configurations.

Table 1.—ARMPS values for unsuccessful pillar design case histories

| Location           | Coalbed                | Source                | Loading condition <sup>1</sup> | ARMPS stability factor | Comments  |
|--------------------|------------------------|-----------------------|--------------------------------|------------------------|---|
| Alabama . . .      | Blue Creek . . . . .   | Mine visit . . . . .  | 2                              | 1.27                   | Pillar squeeze caused panel to be abandoned.  |
|                    | .. do. . . . .         | .. do. . . . .        | 2                              | 1.11                   | Squeeze conditions caused 20 pillars 21 by 21 m (70 by 70 ft) to be lost.   |
| Colorado . . .     | Cameo "B" . . . . .    | Abel (7) . . . . .    | 1                              | 0.57                   | Airblast generated by sudden collapse of 204 by 402 m (670 by 1,320 ft) of 3 by 24 m (10-by 80-ft) fenders.                                 |
| Illinois . . . . . | Herrin No. 6 . . . . . | Chugh (6) . . . . .   | 3                              | .81                    | Roof falls, 56 cm (22 in) of floor heave, and severe sloughage.   |
| Kentucky . . .     | Coalburg . . . . .     | Unrug (16) . . . . .  | 3                              | <sup>2</sup> .72       | Inability to break roof caused excessive pillar spalling and heave.   |
|                    | Harlan . . . . .       | Mine visit . . . . .  | 1                              | .96                    | Coal pillar bump fatally injured roof bolter operator.  |
|                    | .. do. . . . .         | .. do. . . . .        | 1                              | 1.06                   | Squeeze conditions caused 14 rows of pillars to be lost. Most of main entries were closed entirely.   |
|                    | Hazard No. 4 . . . . . | .. do. . . . .        | 3                              | .43                    | Extensive pillar line heave, sloughage, and roof falls caused 9 rows of pillar to be lost.  |
|                    | .. do. . . . .         | .. do. . . . .        | 3                              | .46                    | Squeeze conditions caused 10 rows of pillar to be lost. Numerous roof falls and continuous miner was buried.                                |
|                    | Wallins . . . . .      | .. do. . . . .        | 4                              | .39                    | Severe pillar line weighting. Scores of fenders were lost after pillar splits.  |
| Ohio . . . . .     | Pittsburgh . . . . .   | Artler (2) . . . . .  | 2                              | <sup>3</sup> .45       | Squeeze conditions caused numerous pillars to be lost.  |
| Pennsylvania       | .. do. . . . .         | Mishra (10) . . . . . | 2                              | .79                    | 152 m (500 ft) of pillars were lost in 3 days. Large-scale squeeze 1,600 ft outby pillar line.  |
| Tennessee ..       | Beech Grove . . . . .  | Mine visit . . . . .  | 1                              | 1.34                   | Squeeze conditions essentially closed 671 m (2,200 ft) of main entries.   |
|                    | .. do. . . . .         | .. do. . . . .        | 3                              | .60                    | Section and barrier pillar abandoned because of squeeze conditions.   |
| Utah . . . . .     | Gilson . . . . .       | .. do. . . . .        | 3                              | .44                    | Section abandoned because of violent coal pillar bump.  |
|                    | .. do. . . . .         | .. do. . . . .        | 2                              | .40                    | Excessive roof slaking and subsequent bump due to idle pillar line.   |
| Virginia . . . . . | Pocahontas No. 3 ..    | Campoli (4) . . . . . | 1                              | .56                    | Numerous coal pillar bumps. 274- by 396-m (900- by 1,300-ft) area of pillars was abandoned because of squeeze.                              |
| West Virginia      | Beckley . . . . .      | Mine visit . . . . .  | 4                              | .84                    | Continuous miner was buried for 2 weeks. Crushed out cribs due to 0.9 to 1.2 m (3 to 4 ft) of heave.  |
|                    | .. do. . . . .         | .. do. . . . .        | 4                              | .61                    | Coal pillar bump during pillar split fractured roof bolter operator's leg.  |
|                    | Coalburg . . . . .     | .. do. . . . .        | 1                              | .49                    | Squeeze that occurred in partially pillared workings caused 2 rows of 12- by 15-m (40- by 50-ft) pillars with SF of 1.37 to be lost.        |
|                    | .. do. . . . .         | .. do. . . . .        | 1                              | .66                    | Airblast generated by approximately 100 fenders collapsing blew out 26 cinder-block stoppings and fan-house weak wall. 1 miner was injured. |
|                    | .. do. . . . .         | .. do. . . . .        | 1                              | 1.17                   | 10 rows of 12- by 12-m (40- by 40-ft) pillars were lost because of squeeze conditions.  |
|                    | .. do. . . . .         | .. do. . . . .        | 3                              | 1.31                   | Dangerous pillar sloughage caused scores of pillar to be lost. Barrier pillar was also lost.  |
|                    | Dorothy . . . . .      | .. do. . . . .        | 1                              | 1.40                   | Airblast generated by massive pillar failure blew out 38 stoppings.   |
|                    | Lewiston . . . . .     | Tang (15) . . . . .   | 1                              | .63                    | Massive pillar failure, pillar squeeze, and severe spalling.  |
|                    | .. do. . . . .         | .. do. . . . .        | 1                              | 1.20                   | Do.   |
|                    | No. 2 Gas . . . . .    | Mine visit . . . . .  | 4                              | .83                    | After losing several rows of pillars because of squeeze conditions, section was abandoned for fear of losing bleeders.                      |

See footnotes at end of table.

Table 1.—ARMPS values for unsuccessful pillar design case histories—Continued

| Location              | Coalbed          | Source      | Loading condition <sup>1</sup> | ARMPS stability factor  | Comments   |
|-----------------------|------------------|-------------|--------------------------------|---|--|
| West Virginia (cont.) | Pocahontas No. 4 | Campoli (4) | 3                              | 0.32  | Crushed pillars and floor heave.   |
|                       | .. do.           | Mine visit  | 1                              | 1.03  | Airblast generated by failure of 117 pillars.  |
|                       | Sewell           | Peng (13)   | 3                              | 1.45  | Section abandoned because of concern that floor heave [0.6 to 0.8 m (2 to 2.5 ft)] might prevent equipment retrieval.        |
|                       | Stockton         | Mine visit  | 1                              | .74   | Airblast generated by 140 fenders collapsing blew out 32 stoppings and fan-house weak wall.                                  |
|                       | .. do.           | .. do.      | 1                              | .72   | Airblast generated by 90 fenders collapsing blew out 40 stoppings.   |
|                       | .. do.           | .. do.      | 1                              | 1.29  | Airblast generated by 72 fenders [6 by 12 m (20 by 40 ft)] and 50 pillars [9 by 9 m (30 by 30 ft)] blew out 70 stoppings.    |
| .. do.                | .. do.           | 2           | 1.17                           | Squeeze conditions caused 22 pillars [12 by 14 m (40 by 45 ft)] to be lost. |  |
| NI                    | Lower Kittanning | Tang (14)   | 1                              | ( <sup>4</sup> )  | A massive failure of pillars occurred when pillars to left of chain pillar "A" were split. Severe entry roof falls occurred. |
| NI                    | Taggart          | .. do.      | 1                              | 1.14  | Massive pillar failure 15 crosscuts outby pillar line.   |

Do. Same as above.

NI Not indicated.

<sup>1</sup>Loading condition 1 = development loading; 2 = development and front abutment loading; 3 = development, front abutment, and side abutment loading; 4 = development, front abutment, and loading from two side abutments.

<sup>2</sup>Abutment angle = 90°.

<sup>3</sup>Pillars measuring 4.6 by 12 m (15 by 40 ft) had an SF of 0.45.

<sup>4</sup>Pillars measuring 6 by 6 m (20 by 20 ft) had an SF of 1.32; pillars measuring 3.8 by 13.7 m (12.5 by 45 ft) had an SF of 1.08.

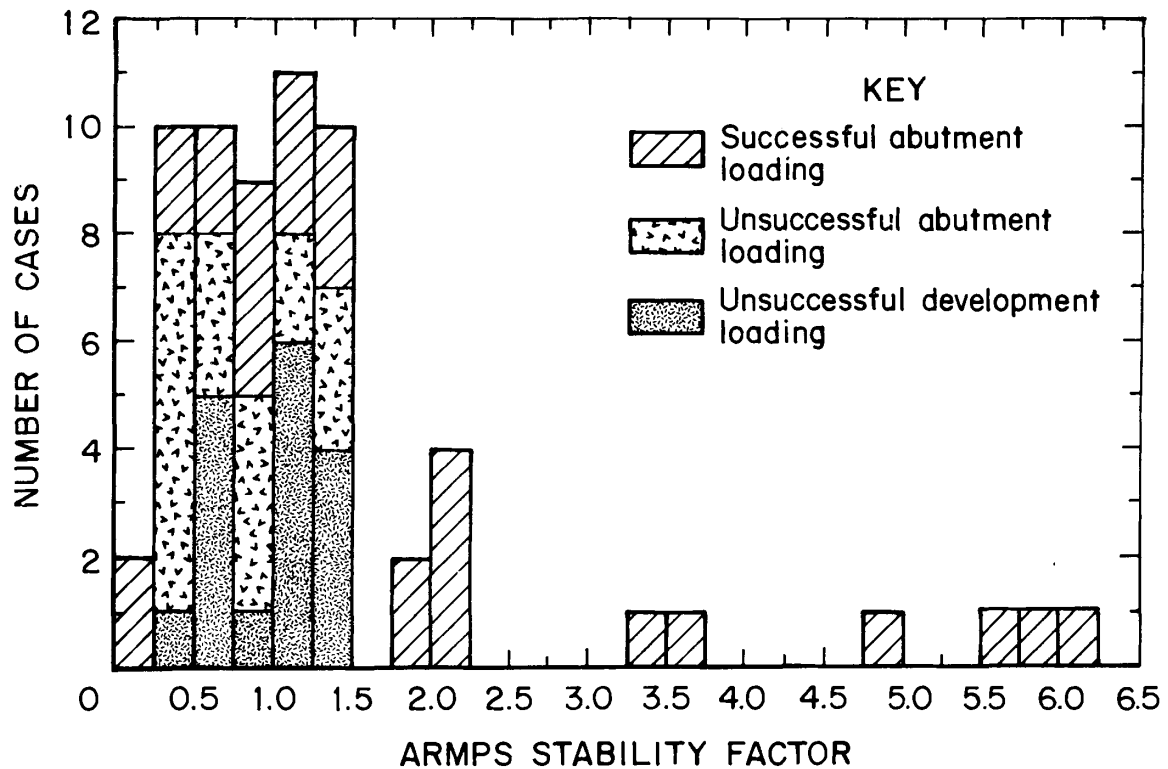

Figure 3.—ARMPS stability factors for case histories.

## ADDITIONAL FACTORS INFLUENCING PILLAR LINE STABILITY

Abutment loads are not the only factor that should be considered in pillar design for retreat mining. Pillar line conditions are also markedly affected by multiple-seam interactions, the rate of pillar line advancement, and roof rock cavability characteristics. In the case of multiple-seam interactions, the best case scenario is to begin with the uppermost seam and to extract it as cleanly as possible. Any barrier, production, or remnants of production pillars (miners refer to these as stumps or sprags) left in the upper seam gob can transfer loads to pillars in the lower seam. However, this is dependent on the thickness and the geology of the interburden and the depth of cover (5, 7). The load transfer is more intense if the pillars and/or stumps left in the upper seam gob are under-designed. In one mine visited in southern West Virginia that had extremely competent roof, the only unintentional fall that ever occurred on the pillar line or in the mine happened directly beneath a barrier pillar. In room-and-pillar retreat mining, the mains, barrier pillars, and panels that are to be retreated should be superimposed for optimum ground conditions.

In virtually every mine visited, operators indicated that the rate of pillar line advancement played a crucial role in overall pillar line conditions. When the pillar line moved slowly or remained idle over the weekend or during a miner's vacation, normally stable pillars began to take weight, as evidenced by sloughage, heave, and even squeeze conditions. Mine operators also remarked that timely pillar line advancement was even more critical when the coalbed thickened because high ribs taking weight caused large rib rolls, which are dangerous to the mine operator and helper.

The caving characteristics of the roof also affect pillar line stability. The Pittsburgh Seam has gained the reputation of having very weak roof where the Pittsburgh Sandstone Member is absent. During pillar retreat, the roof usually breaks directly in by the breaker posts, providing excellent pillar line conditions.

The other extreme roof condition, fairly common in portions of southern West Virginia and areas of eastern Kentucky, occurs where massive sandstones or siltstones [12 m (40 ft) and thicker] are directly above the coalbed. Such roof conditions have been associated with sudden, widespread pillar collapses that, in turn, can cause damaging airblasts (fig. 4). Evidence indicates that massive and competent roof rock units are able to bridge relatively wide spans, particularly when they are aided by the support provided by the regularly spaced remnants of production pillars. When the extraction area is still small, the remnant pillars are not subjected to the full overburden

load because of the stiffness of the roof. A pressure arch is created, with most of the weight being carried by barriers surrounding the extracted area. Eventually, the bridging capability of the main roof can be exceeded, either by overextending the extraction area or by the weakening of the roof and/or remnant pillars over time. Once the pressure arch breaks down, the structural characteristics of the system are such that sudden, massive pillar failures can occur (17). For example, at one of the mines visited during this study, production pillars measuring 12 by 12 m (40 by 40 ft) were split down the middle, leaving 3- by 12-m (10- by 40-ft) fenders in the gob. Shortly after one panel was completed, an area measuring 152 by 152 m (500 by 500 ft) and containing approximately 100 fenders collapsed suddenly. The resulting airblast damaged the fan-house weak wall and 26 stoppings, and closed the mine for days. Fortunately, because of the location of the blast, only one miner was injured.

Underground observations and analysis suggest that two alternative strategies may be successful in preventing airblasts under competent roof conditions. One approach is to limit the partial pillaring conducted in a panel with the intention of designing for long-term stability. This can be accomplished either by increasing the size of the remnant pillars or by periodically leaving rows of unsplit pillars as barriers between smaller areas of split pillars. The latter was successfully employed in a southern West Virginia mine that experienced two moderate-to-severe blasts. The second strategy is to go to full pillar extraction. By removing the support provided by the fenders, the bridging capacity of the roof should be substantially reduced. If the roof does not break during full pillar extraction, caving can be induced through explosives (16).

In another mine visited, pillar splitting was responsible for three significant airblasts. Wanting to arrest the situation, the "Virginia three-cut method" was employed (fig. 5). The sequence in which the lifts are extracted are numbered as shown in figure 5. In the collapsed areas where 12 × 12 m (40 × 40 ft) pillars were split, the extraction percentage was 78% as opposed to 74% using the 3 cut method. However, the 3 cut method leaves non-uniformly spaced stumps that have an irregular geometry in the gob. According to the mine operator, these stumps routinely yielded and crushed out. Since the 3 cut method has been used in this mine, no airblasts have been recorded.

Finally, it appears that massive pillar collapses may be more likely where the floor and roof are strong. Where the floor is weak, the pillars should be more prone to punch, resulting in a pillar line squeeze.



Figure 4.—Concrete stopping damaged by airblast.

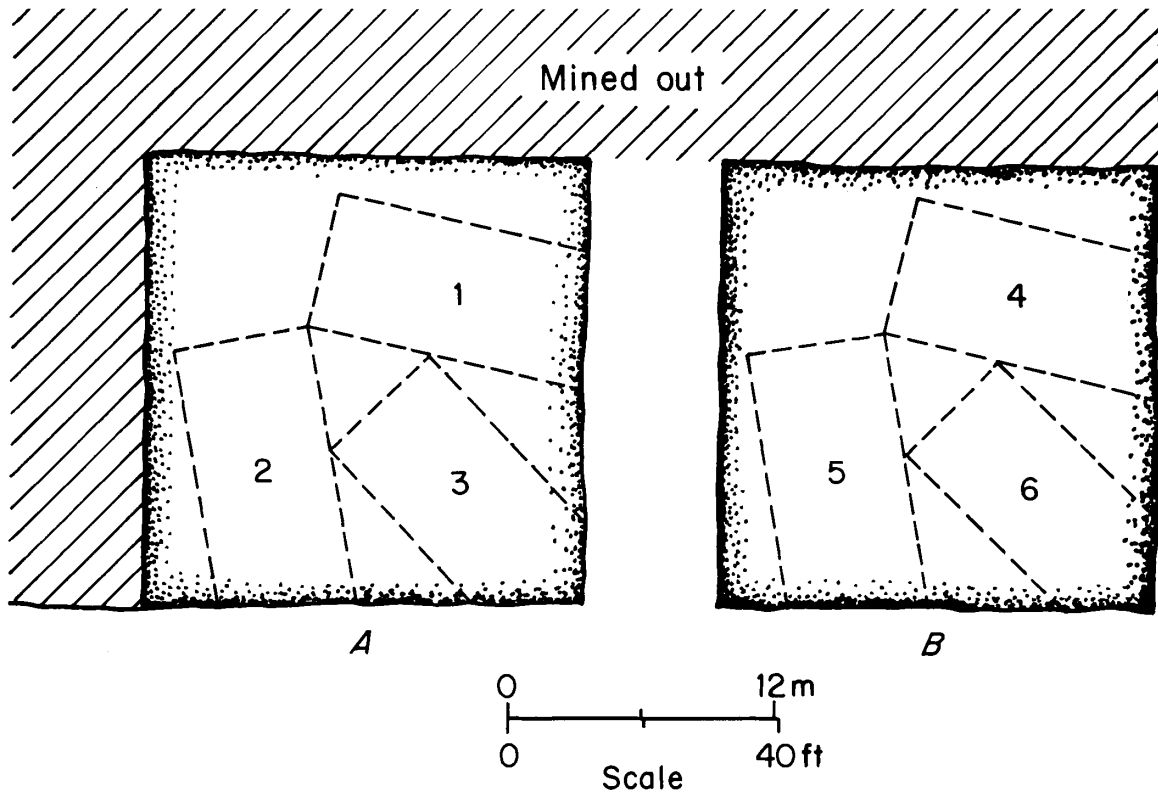

Figure 5.—Virginia three-cut pillar extraction method. A, First pillar mined; B, second pillar mined. (Numbers indicate sequence in which lifts are extracted.)

## CONCLUSIONS

Information gathered during this investigation lends credence to the following conclusions:

1. Properly sized production pillars that are designed considering the front and/or side abutment pressures generated by gob creation can result in better miner safety and more efficient recovery of reserves.
2. Case histories analyzed using the ARMPS method examined an extensive range of geographic locations, depths of cover, width-to-height ratios, roof rock cavability characteristics, floor conditions, and extraction methods that are representative of the population as a whole. It appears that production pillars with an ARMPS SF of 1.50 or greater have a high probability of being extracted without a problem.
3. Multiple-seam interactions can have detrimental effects on pillar line stability. The effect is dependent

upon the sequence in which the seams are mined, the thickness and geology of the interburden, overburden, and the presence of production pillars or stumps left in the gob.

4. Normally stable pillar line conditions often deteriorate if the pillar line moves slowly or remains idle for an extended amount of time. This deterioration can manifest itself in the form of excessive sloughage, heave, and squeezes.

5. Airblasts or squeezes have occurred in mines that have competent and massive roof rock units that will not cave. If partial pillaring is to be conducted under competent roof that will not cave, the long-term stability of the gobbed-out area should be considered. This can be accomplished either by increasing the size of the production pillar remnants or by leaving rows of unsplit pillars as barriers between smaller areas of split pillars.

## REFERENCES

1. Abel, J. F. Soft Rock Pillars. *Int. J. Min. and Geol. Eng.*, v. 6, 1988, pp. 241-245.
2. Artler, L. R. Pillar Design—Continuous Miner Butt Section and Longwall Development Sections. Paper in Proceedings, Fourth Conference on Ground Control in Mining. WV Univ., Morgantown, WV, 1985, pp. 160-165.
3. Bieniawski, Z. T. *Strata Control in Mineral Engineering*. Wiley, 1987, 212 pp.
4. Campoli, A. A., C. A. Kertis, and C. A. Goode. Coal Mine Bumps: Five Case Studies in the Eastern United States. *BuMines IC 9149*, 1987, 34 pp.
5. Chekan, G. J., and R. J. Matetic. Loading Characteristics of Pillars in Multiple-Seam Mining Operations. *BuMines RI 9173*, 1988, 19 pp.
6. Chugh, Y. P., K. V. K. Prasad, and R. Missavage. A Case Study of Geotechnical Studies for an Improved Room-and-Pillar Retreat Mining System in Illinois. Paper in Proceedings of the 27th U.S. Symposium on Rock Mechanics. Univ. AL, Tuscaloosa, AL, 1986, pp. 390-397.
7. Haycocks, C., B. L. Ehgartner, M. Karmis, and E. Topuz. Pillar Load Transfer Mechanisms in Multiple-Seam Mining. *Soc. Min. Eng. AIME preprint 82-69*, 1982, 6 pp.
8. Mark, C. Analysis of Longwall Pillar Stability (ALPS): An Update. Paper in Proceedings of the Workshop on Coal Pillar Mechanics and Design, *BuMines IC 9315*, 1992, pp. 238-249.
9. \_\_\_\_\_. Pillar Design Methods for Longwall Mining. *BuMines IC 9247*, 1990, 53 pp.
10. Mishra, G., and R. L. Grayson. An Engineering Analysis of "Squeeze" Failure of Pillars in the Pittsburgh Coalbed. Paper in Proceedings, First Conference on Ground Control in Mining. WV Univ., Morgantown, WV, 1981, pp. 144-153.
11. Montague, P. G. Pillar Recovery. Paper in Proceedings of the American Mining Congress (Chicago, IL). *Am. Min. Congr.*, Washington, DC, 1988, pp. 531-548.
12. Pappas, D. M. Roof and Rib Fall Accident and Cost Statistics: An In-Depth Study. *BuMines IC 9151*, 1987, 20 pp.
13. Peng, S. S., and P. Tsang. Mechanism and Control of Floor Heave—Development of a Model for Floor Stability Analysis. Paper in Proceedings of the Ninth Annual Workshop, Generic Mineral Technology Center, Mine Systems Design and Ground Control (Lexington, KY, Nov. 10-12, 1991). VA Polytech. Inst. and State Univ., Blacksburg, VA, 1991, pp. 21-25.
14. Tang, D. H., and S. S. Peng. Mine Pillar Stability Analysis Using FEM Methods—Two Case Studies. Paper in Proceedings, Ninth International Conference on Ground Control in Mining. WV Univ., Morgantown, WV, 1990, pp. 88-98.
15. Tang, D. H., S. S. Peng, and C. T. Holland. Massive Pillar Failure—Two Case Studies. Paper in Proceedings, Conference on Ground Control in Mining. WV Univ., Morgantown, WV, 1985, pp. 117-126.
16. Unrug, K. F., J. Tussey, and R. Moore. Pillar Extraction With Application of Mobile Roof Support Eastern Kentucky. *Soc. Min. Eng. AIME preprint 91-101*, 1991, 8 pp.
17. Zipf, R. K., Jr. Analysis of Stable and Unstable Pillar Failure Using a Local Mine Stiffness Method. Paper in Proceedings of the Workshop on Coal Pillar Mechanics and Design. *BuMines IC 9315*, 1992, pp. 128-143.



# SHIFTWORK: A GUIDE FOR SCHEDULE DESIGN

By James C. Duchon<sup>1</sup>

## ABSTRACT

Based upon the perturbed performance, increased or more serious accidents, lowered production, higher absenteeism, health problems, familial problems, low morale, and job dissatisfaction due to working nights and shiftwork, the U.S. Bureau of Mines has analyzed shiftwork schedule design at mining operations. The purpose of this paper is to discuss in practical terms what mining companies can do if they are considering changes in their shiftwork practices. It is not the intent of this paper to

persuade management or any workers that they should change their shiftwork schedule.

This paper discusses various design considerations or dimensions that may vary. These dimensions are (1) fixed versus rotating schedules, (2) speed of rotation, (3) direction of rotation, (4) length of shift, and (5) starting time of shift. Also, extended workdays and other management considerations, such as training and evaluation, are discussed.

## INTRODUCTION

In the mining industry, the proportion of employees working shiftwork is increasing. Data from the U.S. Bureau of Labor Statistics indicate that in 1991, 28.4 pct of all mine employees worked evening, night, or rotating shifts, as compared with 21.9 pct in 1985. Further, the percentage of miners working shifts other than straight days is considerably larger than the combined average of all U.S. industries (17.8 pct).

There are several practical reasons why shiftwork in mining is prevalent, including (1) the increased demand for goods and services combined with limited overhead; (2) the need to maximize costly equipment for quick capital recovery; (3) the need to take advantage of lower utility costs at offpeak-hour utility rates; and (4) the need to keep equipment running continuously because of high startup costs.

It has been demonstrated in published studies that workers in various industrial groups, such as mining, power, chemical, nursing, factory, and oil refineries, have dis-

played perturbed performance, increased or more serious accidents, lowered production, higher absenteeism, health problems, familial problems, low morale, and job dissatisfaction due to working nights and shiftwork (1-10).<sup>2</sup> An excellent review of these effects can be found in a recent document completed by the U.S. Congress, Office of Technology Assessment (1). It is easy to understand, therefore, why there is a growing interest among all industries, including mining, to examine shiftwork interventions.

A discussion of alternative work schedules provided other reasons why there is a recent trend in the United States toward new and better schedules (11). For instance, an increase in relative affluence creates a climate where many of life's privileges and comforts have become necessities. Employees are examining alternative schedules consistent with this. Also, cultural changes, changes in employment rates, an aging work force, labor force participation, and a shift to service work all contribute toward this move to seek alternative schedules.

<sup>1</sup>Engineering research psychologist, U.S. Bureau of Mines, Twin Cities Research Center, Minneapolis, MN.

<sup>2</sup>Italic numbers in parentheses refer to items in the list of references at the end of this paper.

For these reasons the U.S. Bureau of Mines (USBM) has been involved in research on various shiftwork issues to enhance the safety of the mine worker. The purpose of this paper is to discuss in practical terms what mining companies can do if they are considering changes in their shiftwork practices. It is not the intent of this paper to

persuade management or any workers that they should change their shiftwork schedule. In many cases, current work scheduling practices are used successfully. Changes in such situations may, in fact, worsen their situation in spite of all good intentions.

## ERGONOMIC CONSIDERATIONS OF SCHEDULE DESIGN

The perfect shift does not exist. Figure 1 illustrates that there are three ergonomic considerations for any schedule that are associated with various causes and effects, such as production, absenteeism, accident rates, worker fatigue, and morale. These considerations include biocompatibility, sociocompatibility, and job compatibility. A comprehensive assessment of any schedule, therefore, must consider each of these components. While each of these considerations are interrelated, they will for the sake of simplicity be discussed and treated independently.

Biocompatibility refers to how a schedule conforms or does not conform to human physiology that may affect performance. It is well known that humans have innate "biological clocks" that control certain physiological functions. Circadian rhythms are those functions that have an approximately 24-h cycle, such as the excretion of human growth hormone and cortisol potassium, variation of body temperature, and sleep-wake cycle. The sleep-wake cycle refers to the body's natural tendency to

maintain wakefulness during the daylight hours and sleep during the night. There are two observable consequences that can occur as a result of disrupting the sleep-wake cycle. First, remaining awake at night results in fatigue or a feeling of being tired. This fatigue occurs even when "enough" sleep is taken prior to the night shift. Fatigue occurs at night because of a physiological push for sleep manifested by sleepiness, performance deficiencies, lowered body temperature and heart rate, and other signs associated with a need for sleep. When body temperature is used as an indicator of alertness, the trough of this cycle tends to occur at approximately 3:00 a.m. for an individual who is not adjusting to a different schedule or time zone.

A second situation related to circadian rhythms is referred to as occupational jet lag. Just as our bodies adjust to different time zones during travel, so too must our bodies adjust to rotations from day or evening shifts to night shifts. Fatigue, malaise, disturbed sleep, and general flu-like symptoms occur as a result of circadian rhythm

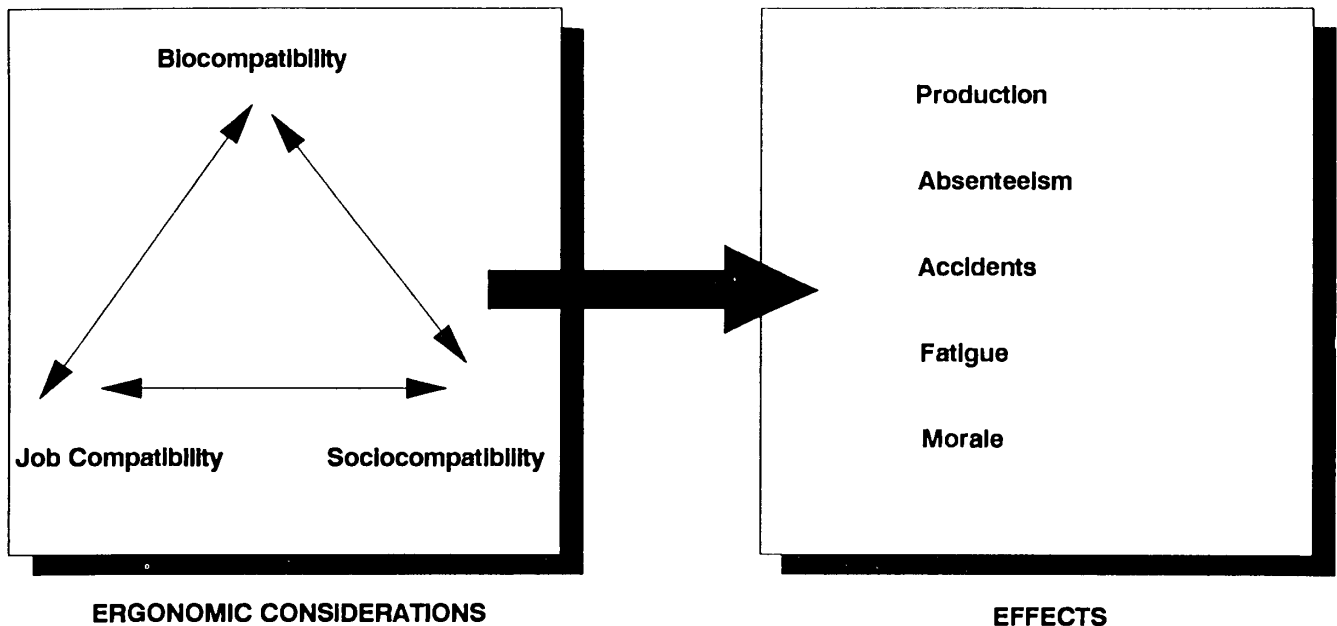

Figure 1.—Ergonomic considerations and effects of shiftwork schedules.

desynchronization and physiological adjustment to the new shift (time zone). Such a biological adjustment to new time zones may take from 3 to 10 days, whereas adjustment to a night shift may take longer or may never occur because of conflicting day-night cycles, i.e., working during the night and sleeping during the daylight hours, as well as conflicting social and family cues on workdays and off days.

Sociocompatibility refers to a compatibility between work schedule design and social-family life schedules. This design consideration is perhaps the most critical aspect from the perspective of the shift worker. The norm in our society is an 8-to-5, Monday-through-Friday schedule. Deviation from this could potentially create social conflict. For many workers, the most disliked shift in this respect is the evening shift. Working between

3:00 p.m. and 11:00 p.m. precludes a satisfactory family-social life. Working weekends, an unavoidable consequence of continuous operations, is a major source of social incompatibility.

Job compatibility refers to how a schedule conforms with or competes with job or organizational demands. For instance, certain companies or industries require training days to be built into a schedule. Some underground mining companies have blasting periods that should be considered in a schedule. Such things as need for weekend work, need for equal personnel across the 24-h day, commuting times for employees, union regulations, exposure to harmful environmental agents, etc. should be considered in the choice of schedule design. Any schedule that involves evening, night, or rotating shifts will create problems for some people.

## MANAGEMENT-LABOR DIFFERENCES

The focus of "important" schedule considerations can be different depending upon one's perspective. Figure 2 illustrates the concerns management and labor typically consider critical in a "good" schedule. Traditionally, management tends to emphasize issues of job compatibility, while labor tends to emphasize issues of sociocompatibility. This is not to say that management ignores the welfare of its employees or that employees do not consider

the job considerations that are necessary for company survival. In fact, insight into each position is ultimately necessary for a successful and workable schedule. Until recently, biocompatibility issues in schedule designs were often ignored. However, research in the past 10 years has evaluated human sleep, biological rhythms, nutrition, etc. in relation to shiftwork schedules and has offered important considerations that should be of value to all parties.

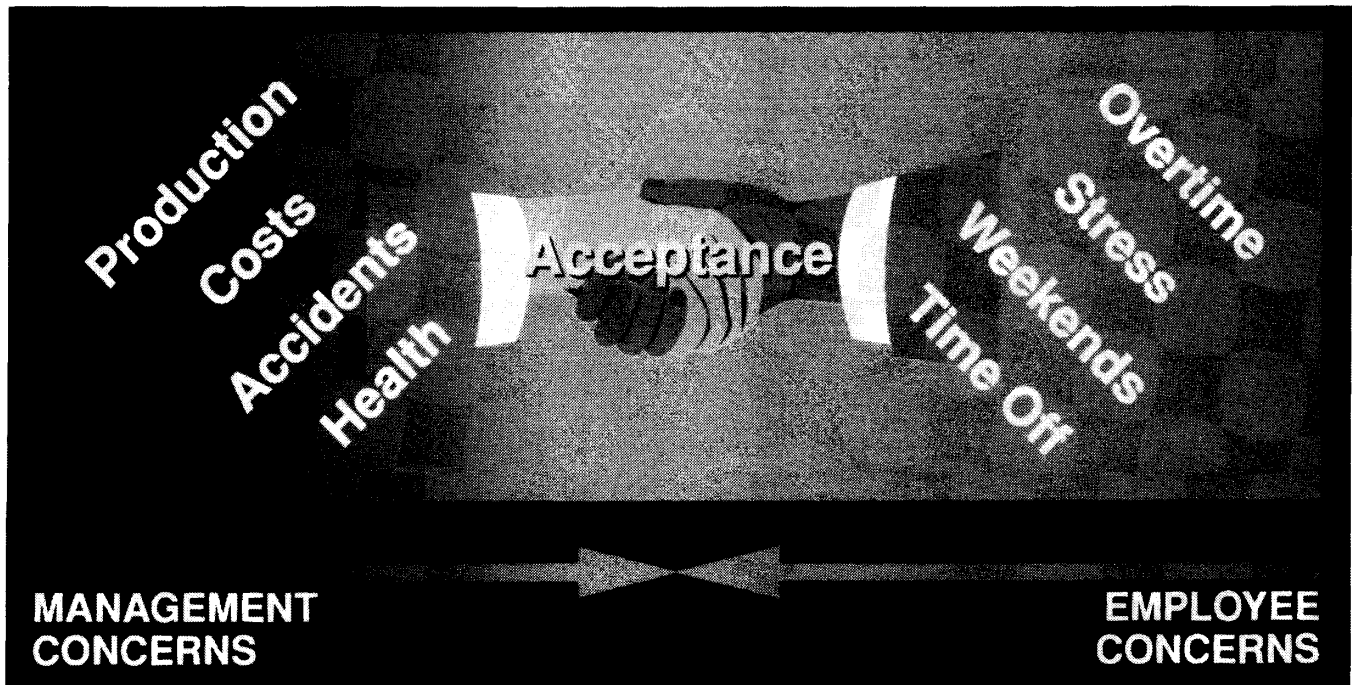

Figure 2.—Critical schedule concerns.

## RECOMMENDATIONS

While there are virtually unlimited schedule designs, there are limited dimensions of the schedule that can vary. These dimensions are (1) night and evening shift, (2) fixed versus rotating shifts, (3) slow or fast rotation schedules, (4) forward or backward rotation, (5) early or late shift start times, and (6) length of shift. The following is a discussion of each of these.

### NIGHT AND EVENING SHIFT

As mentioned earlier, working night shifts has been associated with a variety of health and performance measures. It is the night shift that is incompatible to our body's natural rhythms. The night shift is also disliked by many workers because of social factors. There are situations, however, where individuals prefer working nights because of certain benefits, such as pay differentials and less pressure or less supervision at work. Working nights also allows for more parental involvement in child care and the associated cost savings.

Considering only the criteria of adequate sleep, the evening shift is for most people the perfect shift. Virtually all studies have indicated that the evening shift is associated with the greatest sleep length when compared with the day or night shift. Nevertheless, it is the evening shift that is the least preferred by workers. Clearly, this dislike for the shift is due to issues of sociocompatibility.

#### *Recommendations:*

1. Before anything else, an employer should consider the possibility of decreasing use of night shifts.
2. The use of overtime should be avoided for workers on night shifts. Many workers nap prior to the shift

and begin sleep immediately following the night shift. Therefore, any overtime may eat into the worker's total sleep length, which is already shortened.

3. When night shifts are used, several special precautionary measures should be taken. These are—

- a. Longer or more frequent mandatory rest breaks when work is between midnight and 6:00 a.m.
- b. Physically or mentally difficult assignments should be left for the day or evening shifts.
- c. Ample opportunity for a hot and healthful variety of foods via machine or food cart should be made available to these "offshift" workers.
- d. Lunch breaks should occur at a consistent time of the night shift, i.e., meals should be eaten at approximately the same time each night.

### FIXED VERSUS ROTATING SHIFTS

Fixed or permanent shifts are more common in Monday-through-Friday, 24-h operations. In these 5-day operations, three crews each working day, evening, or night shifts can cover a 24-h operation with either permanent or rotating shifts. However, in **continuous operations**, utilizing 8-h shifts, where each job totals 168 h per week (24 h/d times 7 d/wk), a minimum of four crews is needed to cover all three shifts. Therefore, at least some shift rotation is typically required. The question then becomes, Should the use of permanent shifts be minimized or maximized when possible? Table 1 shows one of the most commonly used schedules in continuous operations. This schedule maximizes rotating shifts by requiring all workers to rotate on a weekly basis. In contrast, table 2 shows a schedule that utilizes three fixed crews (1, 2, and 3) and one rotating or "grasshopper" shift (crew 4).

Table 1.—Schedule consisting of four-crew, 8-h, 7-day backward rotating "Southern Swing" pattern

| Crew-week   | Mon.           | Tues. | Wed. | Thurs. | Fri. | Sat. | Sun. |
|-------------|----------------|-------|------|--------|------|------|------|
| 1 . . . . . | —              | —     | E    | E      | E    | E    | E    |
| 2 . . . . . | E              | E     | —    | M      | M    | M    | M    |
| 3 . . . . . | M              | M     | M    | —      | —    | G    | G    |
| 4 . . . . . | G              | G     | G    | G      | G    | —    | —    |
| E           | Evening shift. |       |      |        |      |      |      |
| G           | Night shift.   |       |      |        |      |      |      |
| M           | Morning shift. |       |      |        |      |      |      |

NOTE.—Dashes indicate off days.

**Table 2.—Schedule consisting of 6-day-on and 2-day-off pattern, repeating every 8 days**

| Crew                     | Mon. | Tues. | Wed. | Thurs. | Fri. | Sat. | Sun. |
|--------------------------|------|-------|------|--------|------|------|------|
| 1 <sup>1</sup> . . . . . | M    | M     | M    | M      | M    | M    | —    |
| 2 <sup>1</sup> . . . . . | —    | —     | E    | E      | E    | E    | E    |
| 3 <sup>1</sup> . . . . . | G    | G     | —    | —      | G    | G    | G    |
| 4 <sup>2</sup> . . . . . | E    | E     | G    | G      | —    | —    | M    |

E Evening shift.

G Night shift.

M Morning shift.

<sup>1</sup>Fixed.

<sup>2</sup>Grasshopper shift, rotating every 2 days.

NOTE.—Dashes indicate off days.

One argument in favor of using fixed shifts, such as permanent days, evenings, and nights, is to allow workers on the night shift to "adjust." However, research has consistently shown that night workers never completely adapt to that shift. Nearly all night permanent shift workers revert to a "normal" day schedule on their days off. They are, therefore, constantly rotating their work-sleep cycles in spite of having a fixed shift. Several studies have indicated that permanent night workers, as do rotating shift workers, tend to sleep several hours less before the night shift than any other shift. Working consecutive night shifts, therefore, may result in a cumulative "sleep debt." A summary of the pros and cons of fixed versus permanent shifts is as follows:

#### *Advantages of Fixed Shifts:*

1. Often allows workers to choose the evening or night shifts. These shifts are actually more sociocompatible for some workers.
2. Allows a large percentage of employees to avoid the night shift altogether.
3. Less disorienting since rotation among the other shifts is not required.

#### *Advantages of Rotating Shifts:*

1. A "fair" schedule. No preferences given to individuals for the favored shifts.
2. Minimizes the exposure to the night and evening shift to any particular group of employees by "spreading out" the exposure among all employees.
3. If rotations are fast (see next section) then there may be less physiological disruption of circadian rhythms, i.e., occupational jet lag would not be an issue.

#### *Recommendations:*

1. The primary consideration should be the possibility of the reduction of the work force on the night shift.
2. Unless the night shift and the evening can be filled by workers voluntarily choosing to work permanent shifts, rotating shifts are recommended.

### **SLOW OR FAST ROTATION SCHEDULES**

Rotating shifts can differ with respect to how quickly workers rotate from one shift to another, or the number of contiguous days on each shift. In U.S. mining operations, rotations tend to be as short as 1 week and as long as 2 or more weeks on the same shift. It is not typical to find "rapid" rotations of 1 or 2 days, as is found in some service industries or as is typical in the European community. The rapid rotation will be discussed below.

There are reasonable hypotheses for suggesting either the 1 week, or the slower rotation cycles of 2 or more weeks. On the one hand, it can be argued that it is more advantageous to work shorter stretches of nights to avoid a cumulative sleep deprivation that may occur with too many contiguous night shifts (12). On the other hand, it can be argued that a slower rotation has the advantage of letting workers adjust to night shifts, thereby lessening the negative effects of night work (13).

The USBM conducted a study to determine whether or not there is an advantage to working the second week of a 2-week cycle, as would be indicated by reports of more positive health, mood, and sleep items on the second week as compared with the first week (14). Forty-two workers at a surface mine in the Midwest filled out the work, food, and sleep diary for 4 to 6 weeks. They rotated every 2 weeks, going from days to nights to evenings with all

weekends off. The dependent measures were defined as (1) health, the daily frequency of reported symptoms; (2) mood, based on a self-evaluation of four descriptors—alert, sleepy, grouchy, and relaxed; (3) total sleep length; and (4) sleep quality. Results indicated that on the second week of the night shift, workers reported significant improvements in all four mood descriptors for the second half of their shift. Also, sleep quality as measured by awakenings during sleep improved on the second week of the night shift. None of the variables showed a worsening on the second week of nights. These results do not support a "cumulative trauma" effect for the schedule studied in this paper. On the basis of this study, it could be recommended that 2-week cycles are superior to 1-week cycles.

However, a truly fast rotation schedule, rarely used in U.S. industries, is common in European countries. Table 3 shows a typical fast rotating schedule. Experts agree that there are several advantages to fast rotating shifts

(15-17). First, individuals do not have time enough on any shift to adjust his or her circadian rhythms, thereby avoiding the physiological dyschrony associated with working stretches of night shifts. Second, working only two or three consecutive nights does not allow a sleep debt to occur, which is associated with working several consecutive nights. Third, short stretches of nights allow for more regular social contacts.

*Recommendations:*

1. On a rotating schedule, it is recommended that schedules have 2 weeks of a particular shift (with days off), as compared with 1 week. Table 4 shows an example of a schedule for an eight-worker continuous operation, utilizing 2-week rotations.

2. A fast rotation, such as the one shown in table 3, may be considered as an alternative for those groups of workers wanting to avoid long stretches of night shifts.

**Table 3.—Rapid rotation schedule often used in European work systems<sup>1</sup>**

| Crew-week   | Mon. | Tues. | Wed. | Thurs. | Fri. | Sat. | Sun. |
|-------------|------|-------|------|--------|------|------|------|
| 1 . . . . . | M    | M     | E    | E      | G    | G    | G    |
| 2 . . . . . | —    | —     | M    | M      | E    | E    | E    |
| 3 . . . . . | G    | G     | —    | —      | M    | M    | M    |
| 4 . . . . . | E    | E     | G    | G      | —    | —    | —    |

E Evening shift.

G Night shift.

M Morning shift.

<sup>1</sup>This schedule requires four crews working a repeating 2-2-3 pattern. For instance, crew 1 works 2 days, two evenings, three nights, 2 off days, two day shifts, two evening shifts, etc.

NOTE.—Dashes indicate off days.

**Table 4.—Crewless schedule consisting of 2 contingent weeks of nights<sup>1</sup>**

| Employee-week | Mon. | Tues. | Wed. | Thurs. | Fri. | Sat. | Sun. |
|---------------|------|-------|------|--------|------|------|------|
| 1 . . . . .   | —    | M     | M    | M      | M    | M    | M    |
| 2 . . . . .   | M    | —     | —    | M      | M    | M    | M    |
| 3 . . . . .   | M    | M     | M    | —      | —    | M    | M    |
| 4 . . . . .   | E    | E     | E    | E      | E    | —    | —    |
| 5 . . . . .   | —    | G     | G    | G      | G    | G    | G    |
| 6 . . . . .   | G    | —     | —    | G      | G    | G    | G    |
| 7 . . . . .   | G    | G     | G    | —      | —    | E    | E    |
| 8 . . . . .   | E    | E     | E    | E      | E    | —    | —    |

E Evening shift.

G Night shift.

M Morning shift.

<sup>1</sup>This schedule requires eight shift workers covering two positions around the clock. The shift workers are placed at 1-week intervals in an 8-week cycle.

NOTE.—Dashes indicate off days.

Source: Circadian Technologies, Inc.

## FORWARD OR BACKWARD ROTATION

One popular suggestion offered by shiftwork experts is to prescribe schedules that rotate in a forward direction. Rotating from a day to evening to night shift (table 5) is preferred over rotating from a day to night to evening shift (table 1). Unfortunately, there are virtually no published studies that have systematically reversed **ONLY** the direction of the shift rotation in a mining or industrial setting that would show the benefit of such an intervention. There are, however, a few studies that have made shift changes, which have included direction of rotation as one part of the total change. For instance, the most widely cited study is the intervention study at Great Salt Lake Minerals (10). In this study, the group that changed to a forward direction **AND** went from a weekly to a 21-day rotation schedule improved on measures of health, production, and turnover.

There are two viewpoints as to why there may be benefits using a forward rotating schedule:

Premise 1: First, Knauth and Rutenfranz (16) state that for a discontinuous three-shift system with a five-shift, two-days-off pattern: (1) a forward rotation produces a 72-h-off period between a day and evening shift, a 72-h-off period between an evening and night shift, and a 48-h-off period between a night and day shift, and (2) a backward rotation produces a 56-h-off period between a night and evening shift, a 56-h-off period between an evening and day shift, and an 80-h-off period between a day and night shift. The shorter the off period, the less time for rest and recovery. Therefore, they conclude that since a forward rotation produces only one short, between-shift interval and a backward rotation produces two short, between-shift intervals, the forward rotation is recommended.

Premise 2: A second and more popular reason for prescribing the forward rotation relates to circadian rhythms that are disrupted during phase advances or delays. Since

humans have circadian rhythms that are over 25 h, it is easier to phase delay than to phase advance. Phase advances merely refer to adjustment of our circadian rhythms to earlier clock times. Phase delay refers to adjustment to later clock times. Research has shown that transmeridian air travelers have a much easier time adjusting to westward travel ("phase delay" or forward rotation) as opposed to eastward travel ("phase advance" or backward rotation) (18-20). Based on this research, many authors have recommended that shift rotation schedules take advantage of this finding by constructing schedules with forward rotations to hasten adjustment to each new shift (10, 16, 21-22). Unfortunately, no single study has compared the patterns of adjustment or completeness of adjustment for a group of shift workers who have rotated in each direction with all other factors being equal. In fact, no study has demonstrated complete circadian adjustment for shift workers rotating in either direction.

The USBM challenged these viewpoints using an analysis based upon sleep times taken from survey data and attempted to evaluate the argument that forward rotations are **BETTER** than backward rotations. The primary concern in rotating shiftwork is rotating onto and off of the night shift. Therefore, each between-shift interval prior to or subsequent to a night shift was scrutinized. This paper is based on sleep timing only. Other factors that could influence adjustment, such as eating and social behaviors, internal biological functions, and rhythms should not be ignored.

Night shifts are typically considered either the first or third shift, depending upon the placement within the overall schedule. For instance, in a Monday-through-Friday workweek, a night shift is the first shift if it begins at or about Sunday night and ends Monday morning. However, a night shift is considered the third shift if it begins late Monday night and ends early Tuesday morning.

Table 5.—Schedule consisting of four-crew, 8-h, 7-day forward rotating pattern

| Crew-week   | Mon.           | Tues. | Wed. | Thurs. | Fri. | Sat. | Sun. |
|-------------|----------------|-------|------|--------|------|------|------|
| 1 . . . . . | —              | —     | M    | M      | M    | M    | M    |
| 2 . . . . . | M              | M     | —    | E      | E    | E    | E    |
| 3 . . . . . | E              | E     | E    | —      | —    | G    | G    |
| 4 . . . . . | G              | G     | G    | G      | G    | —    | —    |
| E           | Evening shift. |       |      |        |      |      |      |
| G           | Night shift.   |       |      |        |      |      |      |
| M           | Morning shift. |       |      |        |      |      |      |

NOTE.—Dashes indicate off days.

It was shown that when nights are the third shift, the recovery interval after the night shift on both the forward and backward rotations are "short" intervals (figs. 3-4). However, the forward rotation contains only one full night's sleep and two shortened sleep times. Further, the day shift follows this, which could itself contribute to sleep deprivation. On the backward rotation, the recovery interval after a night shift contains two full night's sleep, following a shortened day sleep. The next afternoon series could actually help in recovery since these shifts are associated with the longest sleep lengths of any shift.

When nights are the first in the series, the recovery intervals after a night shift are relatively long for both forward and backward shifts. However, the backward rotation contains a potential for three full night's sleep, as opposed to only two full night's sleep for the forward rotation.

Therefore, when primary importance is placed upon recovery from night shifts, if nights are the third in the series, the backward rotation is the most desirable.

The amount of sleep and time off prior to working a series of night shifts was also inspected (figs. 3-4). Ideally, individuals who are well rested will have a better chance of adjusting and coping with their night shifts. Where nights are the third in the series, both the forward and

backward rotations have a long between-shift interval prior to the night shift, 72- and 80-h, respectively. Both allow three separate sleep periods to recover from the night shift.

Where nights are the first in the series, both the forward and backward rotations have a "short" between-shift interval, 48-h and 56-h, respectively. The day-to-night shift change on the backward schedule and the evening-to-night shift change on the forward schedule have only two nighttime sleep periods.

Therefore, when analyzing sleep behaviors prior to night shifts, having nights as the third shift for both forward and backward shifts are more desirable than having nights as the first shift.

Perhaps the more popular reason for promulgating the forward rotation is its apparent consistency with the idea that it is biologically quicker to adjust when rotating in the forward direction than in the backward direction. Forward rotations have been compared with east to west travel, where sleep-wake cycles are phase delayed; i.e., sleep occurs later than what has been typical for an individual. Just looking at work start times, it appears that workers are phasing in a forward direction; i.e., day to evening to nights. However, when looking at the sleep-wake cycles of actual workers, they are not consistently rotating forward.

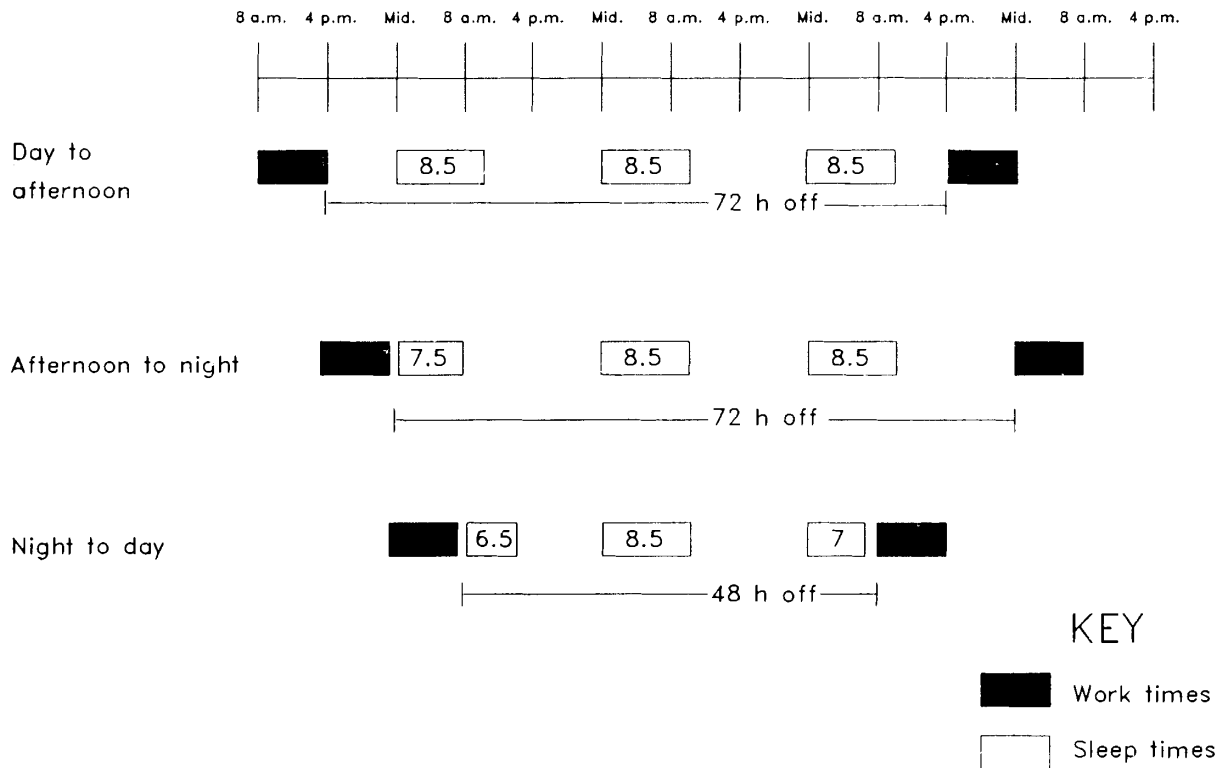

Figure 3.—Forward rotation with night as third shift. (Mid. = midnight)



Based upon typical sleep times, the number of phase advances and phase delays are exactly equal for forward and backward rotating shift workers. Adjustment, therefore, should be the same for both conditions.

*Recommendations:*

1. Where the speed of rotation is relatively slow (i.e., 1 week or more), the preferred direction of rotation is linked to the amount of time off between changes. The amount of time off is related to the position of the night shift, first versus third. An analysis of time off and typical sleep periods indicates that the backward rotation with nights as the first shift may be more conducive for recovery from a stretch of nights. However, a backward rotation with nights as the third shift offers the best opportunity for sleep in preparation and recovery from the night shift. In general, it is suggested that there should be at least 56 h between the last of a series of night shifts and the next of a series of shifts.
2. For fast rotations, as shown in table 3, forward rotations are recommended.

**EARLY OR LATE SHIFT START TIMES**

Various factors can influence a preferred start and end time. In the realm of job-compatibility, certain factors should be considered. For instance, daily blasting schedules are often coordinated with shift start times for underground mines, since evacuation of the mine is necessary. Sociocompatibility issues involve such concerns as driving through rush hour and being home at particular times to coincide with meal times or child care. Biocompatibility issues include such concerns as sleep quality and sleep length, as well as individual differences such as morning and evening types. Morning types or larks are those individuals who tend to prefer to go to bed early and wake up early. Evening types or owls are those individuals who prefer to go to bed late and wake up late. This factor may be an important consideration as the work force ages. Older workers are associated with being morning types.

In general, research has shown that when working a day shift, sleep length decreases with earlier work start times. Also, sleep taken between night shifts are of shorter duration the later the work times start and end. Therefore, to

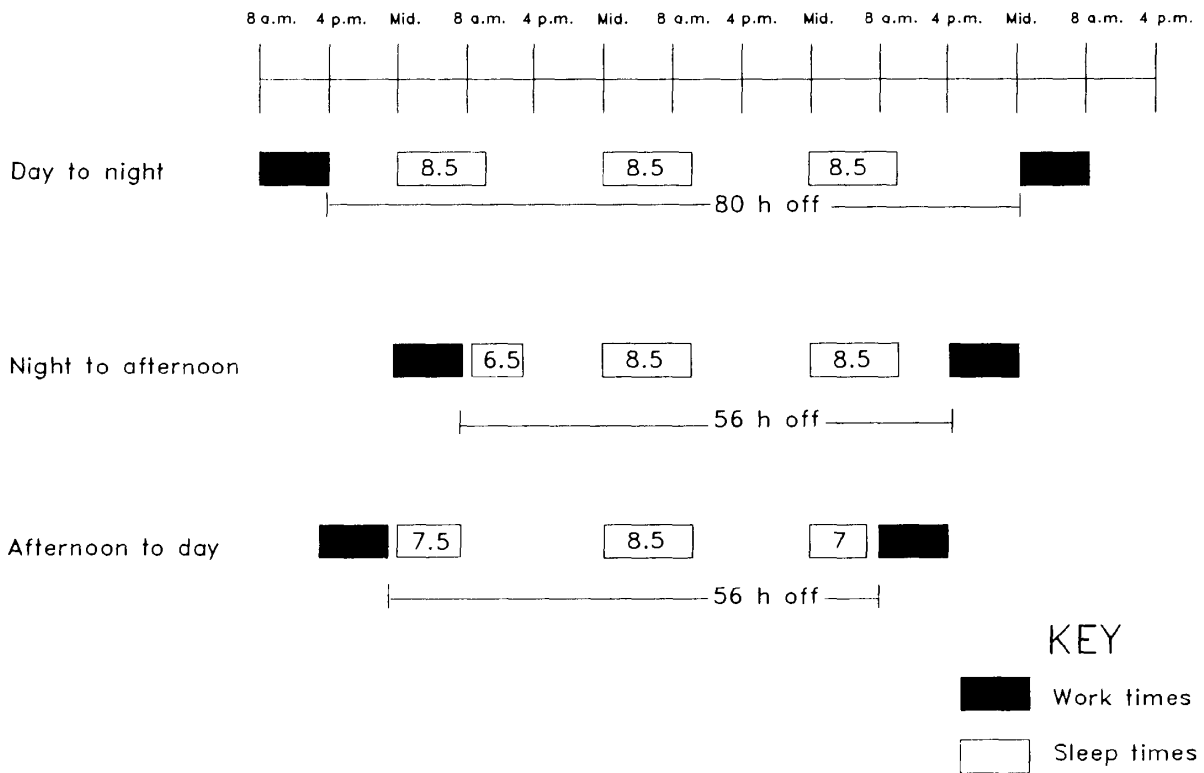

Figure 4.—Backward rotation with night as third shift. (Mid. = midnight)

maximize sleep length before the morning shift, the shift should not start too early. However, to maximize sleep length after a night shift, the shift should not end too late.

Knauth and Rutenfranz (16) discussed studies of start times in various industries. In a coal mine, an experimental change on the day shift from a 6:00 a.m. to a 7:00 a.m. start time was associated with a 23.8 pct accident rate decrease. Similar findings of later start times being associated with fewer accidents or error rates have been found with bus drivers and train drivers. The study also suggested that earlier start times on a "late shift," between 1:00 p.m. and 4:00 p.m., was associated with more frequent accidents.

#### Recommendations:

1. On a one-shift system (i.e., a day shift), a 7:00 a.m. to 9:00 a.m. start time is suggested.
2. For 24-h operations, it is suggested that a 7:00 a.m.,  $\pm 30$  min start time be employed. A later start time will hamper the ability of night shift workers to get adequate sleep.
3. Ideally, a flexible start time should be used if possible. This allows for individual preferences and differences.

### LENGTH OF SHIFT

There is very little doubt that "extended workdays," regular shifts of 10 or 12 h, maintaining an approximately 40-h week, is a very popular alternative among the work force because of the significant increase in days off, including weekends, especially when compared with traditional rotation schedules of working seven straight shifts or having only one weekend off every 4 to 6 weeks.

While the popularity of extended workdays has been on the increase, there are some serious concerns by management, workers, unions and various governmental policy-makers that working 10- or 12-h days may create an added risk of accidents and health problems (23). Unfortunately, there is very little objective information available regarding

the nature and degree of safety and health risks associated with the application of extended workday schedules (1, 24-25). As a consequence, when it comes to questions of designing and managing extended workdays, decisionmaking by management must now proceed on limited information.

Health and safety issues are not important considerations for the implementation of 12-h shifts in relatively safe workplaces such as white collar settings. However, in labor-intensive and environmentally stressful conditions as in mining, where accidents and health are major concerns, or where safety is a public concern as in the nuclear power industry, the application of long workdays must be carefully analyzed. Since all indications are that the application of extended workday schedules by U.S. industries will become increasingly widespread over the decade, it is imperative that a careful and comprehensive evaluation of safety and health risks associated with such schedules be initiated. In a report requested by the House Committees on Appropriations; Energy and Commerce; Science, Space, and Technology; Veterans Affairs, and the Senate Subcommittee on Science, Technology, and Space of the Office of Technology Assessment, it was stated that there is "... a compelling need for more studies of the interactions between work schedules and safety in the workplace" (1, p. 18).

The change from an 8-h rotating shift to a 12-h rotating shift implies several critical schedule differences (26). Below are the crucial similarities and differences between 8-h rotating shifts and 12-h rotating shifts. These are the factors that could make a difference in workers' tolerance to their schedules:

1. Length of the workday.—An extended workday is typically considered a 10- or 12-h workday, while still maintaining an approximately 40-h workweek. Table 6 shows an example of "2-3-2 every other weekend off" extended workday schedule.<sup>3</sup>

<sup>3</sup>This schedule is the continuous pattern of the days on-days off sequence; i.e., two shifts on, followed by 3 days off, followed by two shifts on, followed by two shifts off, etc.

Table 6.—Schedule consisting of two-three-two,<sup>1</sup> every other weekend off, 12-h shift pattern

| Crew-week   | Mon. | Tues. | Wed. | Thurs. | Fri. | Sat. | Sun. |
|-------------|------|-------|------|--------|------|------|------|
| 1 . . . . . | —    | D     | D    | —      | —    | D    | D    |
| 2 . . . . . | D    | —     | —    | D      | D    | —    | —    |
| 3 . . . . . | —    | N     | N    | —      | —    | N    | N    |
| 4 . . . . . | N    | —     | —    | N      | N    | —    | —    |

D 12-h day shift.  
N 12-h night shift.

<sup>1</sup>This schedule is the continuous pattern of the days on-days off sequence; i.e., two shifts on, followed by 3 days off, followed by two shifts on, followed by two shifts off, etc.

NOTE.—Dashes indicate off days.

2. Amount of time off between workdays.—Extended workdays typically have less off-time between shifts. This would have implications for physical recovery from fatigue and potentially less time for sleep.

3. Length of the workweek.—Extended workweeks typically have shorter workweeks at the expense of longer workdays. This could have implications for adaptation of circadian rhythms or less cumulative fatigue across a workweek (27).

4. Amount of time off, i.e., length of "weekends."—Extended workdays usually allow more days off. This would have implications for recovery from fatigue or sleep deficit.

5. Speed of rotation.—U.S. shift workers usually rotate slowly, 1 week or more on any one shift. Extended workdays usually require faster rotations, 2 to 4 consecutive days, which would have implications for adaptation to circadian rhythms.

6. Time of day.—Both 8-h schedules and 12-h schedules can involve around-the-clock operations. Therefore, working the night shift will still be an issue in extended workdays.

The USBM conducted a study designed to examine the safety and health implications of extended workdays at an underground copper, lead, and zinc mining operation (28). Measures were taken before and after a change from the old 7-days-on, 2-days-off, 8-h continuous schedule to the new 4-days-on, 4-days-off, 12-h continuous schedule. These measures included (1) behavioral performance measures to analyze perceptual-motor changes, (2) continuous heart-rate monitoring and aerobic capacity to measure physical fatigue, (3) pulmonary-respiratory measures to examine air contaminant exposure, and (4) a variety of self-report questionnaires to measure perceived adaptation and satisfaction with the new schedule. A control group consisting of 5-days-on, 2-days-off day shift workers at the same mine was also included.

Survey results indicated an overwhelming support for extended workdays at the underground copper, lead, and zinc mine (28). However, self-reported mood scales and the Stanford Sleepiness Scale indicated that workers on the 12-h night shift experienced more sleepiness and lowered energy-alertness levels after the eighth hour into their shift. The 12-h shifts did not seem to be associated with a decrease in most measures of performance across the shift. Only on one measure of physical endurance task (tapping lapses) was there a decrease in performance across the shift for the 12-h night shift. Most of the physiological and pulmonary data indicated few differences between the 8- and 12-h shifts.

In this study, because of the remote location of the mine, the workers on 12-h shifts were expected to lodge at

the minesite during their 4-day shift week. This undoubtedly had a beneficial effect on the sleep and rest between shifts. This was confirmed by the diary data that indicated improved sleep quality and no lessening of sleep length, as compared with the workers' 8-h schedule.

Based upon the overall acceptance of the new schedule by the workers and lack of evidence to suggest serious performance decrements, it was recommended that the mine retain the 12-h schedule, with certain precautionary measures to ensure the safety of the workers. Such measures included maintenance of the on-site lodging for 12-h workers, continuous observation and evaluation of group and individual adjustment, and customizing work tasks and work breaks to accommodate longer work hours.

In an area fraught with inconsistencies, there are several valid comments that can be safely made: (1) workers tend to embrace the use of extended workdays; (2) in spite of item 1 above, some studies in some industries have shown performance and/or safety decrements associated with extended workdays; and (3) more research on extended workdays is needed, especially for companies and industries considering the use of extended workdays where safety is of major importance. These conclusions underscore the need for caution by companies using or considering the use of extended workdays. Based upon this review, it is recommended that the use of extended workdays be accompanied by special efforts to create safe working conditions. Also, since no *a priori* predictions from prior research can be made with certainty about the probable consequences of introducing 10- or 12-h shifts into a mining company, evaluation of each miner should be made on a periodic basis.

#### *Recommendations:*

The use of extended workdays is recommended provided that certain precautions are considered. These are—

1. Extended workdays should not be considered where the frequency of accidents or near-miss accidents are at unacceptable levels. The use of extended workdays should not be expected to reduce the likelihood of accidents.

2. Extended workdays should not be considered for jobs that require extremely high physical workloads. For example, the American Industrial Hygiene Association recommends a workload not to exceed one-third  $VO_{2max}$  (maximum aerobic capacity) for an 8-h workshift. While similar recommendations have not been made for extended workdays, this standard should be strictly enforced.

3. Job sharing and cross training should be considered where extended workdays are used. Since vigilance, boredom, and mental or physical fatigue can lead to errors, changing job tasks may alleviate these stressors.

4. Workers should not be expected to work overtime on extended workdays. Working on scheduled days off is not recommended.

5. If extended workdays are used, regular evaluation and assessment should be undertaken. For instance, survey methods have been developed by the USBM to

evaluate schedules before and after changes are made (29). Also, long-term monitoring of health, accident, and production effects should be considered.

6. Hybrid schedules that utilize both 8- and 12-h shifts should be considered. Table 7 is an example of a schedule utilizing both 8- and 12-h shifts.

Table 7.—Hybrid schedule consisting of both 8- and 12-h shifts

| Crew-week   | Mon. | Tues. | Wed. | Thurs. | Fri. | Sat. | Sun. |
|-------------|------|-------|------|--------|------|------|------|
| 1 . . . . . | E    | E     | E    | E      | E    | —    | —    |
| 2 . . . . . | —    | M     | M    | M      | M    | M12  | M12  |
| 3 . . . . . | M    | —     | —    | —      | G    | G12  | G12  |
| 4 . . . . . | G    | G     | G    | G      | —    | —    | —    |

E Evening shift.

G Night shift; third shift of the day, running from 11 p.m. to 7 a.m.

G12 Shifts from 7 p.m. to 7 a.m.

M Morning shift.

M12 Shifts from 7 a.m. to 7 p.m.

NOTE.—Dashes indicate off days.

Source: Circadian Technologies, Inc.

## MANAGEMENT CONSIDERATIONS

*Changing a schedule:* Equally important to the new schedule itself is how the process of choosing a schedule is carried out. There is not a single method that has been shown to be the best. A prescription for failure is for any one manager to take it upon himself or herself to decide upon a schedule and implement it without consulting those workers who would be affected by the change. This method, although seemingly efficient, sets up the potential for suspicion and inaccurate assumptions that could lead to possible rejection of the schedule, regardless of how good it is.

The following steps are recommended as one way that has proven effective:

1. Construct a company-wide shiftwork committee.
2. Evaluate work problems and worker needs. Social requirements of a schedule can be determined at this time. Focus groups or surveys can be used at this step.

3. Determine operational requirements.
4. Design alternative work schedules that consider the information from steps 2 and 3.
5. Evaluate alternative work schedules. This evaluation is based upon the opinions of the shiftwork committee, experts in the field, and/or other workers.
6. Choose three alternatives for a vote.
7. Make the shiftwork change.
8. Evaluate the change 6 months, 1 year, and every year thereafter. If the presurvey was used for evaluation, a postsurvey can be used as a basis of comparison. Inform the work force of the results of the evaluation.
9. Decide to keep or reject the schedule.

*Training and followup:* Offer training to the shift workers in ways to cope with shiftwork. Involve family members in this training.

## SUMMARY

For the vast majority of the work force, any schedule that involves hours outside the parameters of a "normal" schedule (i.e., 9 to 5), will involve sacrifice and physical and psychological distress. There seems to be, however, schedules that are better than others. This paper presents various aspects of schedules that have been studied and

reported upon. The literature is full of studies and reports of actual work settings that have changed schedules with positive outcomes. Shiftwork practice is an ergonomic consideration, where the fit between the worker and workplace may have serious consequences caused by job, sociological, and biological compatibility.

## REFERENCES

1. U.S. Office of Technology Assessment (Congr.). *Biological Rhythms: Implications for the Worker*. U.S. GPO, Sept. 1991, 249 pp.
2. Andlauer, P. Shift Work. Ch. in *Encyclopedia of Occupational Health and Safety, Volume II*. Int. Labour Off., Geneva, Switzerland, 1972, pp. 2023-2027.
3. Carpentier, J., and P. Cazamian. *Night Work: Its Effects on the Health and Welfare of the Worker*. Int. Labour Off., Geneva, Switzerland, 1977, 85 pp.
4. Walker, J. Social Problems of Shiftwork. Ch. in *Hours of Work*, ed. by S. Folkard and T. Monk. Wiley, 1985, pp. 211-225.
5. Johnson, L. C., D. I. Tepas, W. P. Colquhoun, and M. J. Colligan (eds.). *Biological Rhythms, Sleep, and Shift Work*. Spectrum Publ. (New York), 1981, 618 pp.
6. Reinberg, A., N. Vieux, and P. Andlauer (eds.). *Night and Shift Work: Biological and Social Aspects*. Pergamon, 1981, 509 pp.
7. Rutenfranz, J. Occupational Health Measures for Night- and Shift Workers. Ch. in *Journal of Human Ergology* 11. Cent. Acad. Publ., Tokyo, Japan, 1982, pp. 67-86.
8. LaDou, J. Health Effects of Shift Work. *West. J. Med.*, v. 137, 1982, pp. 525-530.
9. Moore-Ede, M. C., and G. S. Richardson. Medical Implications of Shift-Work. *Annu. Rev. Med.*, v. 36, 1985, pp. 607-617.
10. Czeisler, C. A., M. C. Moore-Ede, and R. M. Coleman. Rotating Shift Work Schedules That Disrupt Sleep Are Improved by Applying Circadian Principles. *Science*, v. 217, 1982, pp. 460-464.
11. Cohen, A. R., and H. Gadon. *Alternative Work Schedules: Integrating Individual and Organizational Needs*. Addison-Wesley Publ., Reading, MA, 1978, 137 pp.
12. Folkard, S., D. S. Minors, and J. M. Waterhouse. *Chronobiology and Shift Work: Current Issues and Trends*. *Chronobiologia*, v. 12, 1985, pp. 31-54.
13. Winget, C., L. Jughes, and J. LaDou. Physiological Effects of Rotational Work Shifting. *J. Occup. Med.*, v. 20, 1978, pp. 204-210.
14. Duchon, J. C., and C. M. Keran. The Adjustment to a Slowly Rotating Shift Schedule: Are Two Weeks Better Than One? Paper in *Proceedings of the Human Factors 34th Annual Meeting* (Orlando, FL, Oct. 8-12, 1990). *Hum. Factors Soc.*, 1990, pp. 899-903.
15. Knauth, P. The Design of Shift Systems. *Ergonomics*, v. 36, Nos. 1-3, 1993, pp. 15-18.
16. Knauth, P., and J. Rutenfranz. Development of Criteria for the Design of Shift Work Systems. *J. Hum. Ergology*, v. 11 Suppl., 1982, pp. 337-367.
17. Eastman Kodak Company. *Ergonomic Design for People at Work*. Von Nostrand Reinhold, New York, NY, v. 2, 1986, 603 pp.
18. Klein, K. E., H. M. Wegmann, and B. I. Hunt. Desynchronisation as a Function of Body Temperature and Performance Circadian Rhythm as a Result of Outgoing and Homecoming Transmeridian Flights. *Aerospace Med.*, v. 43, 1972, pp. 119-132.
19. Klein, K. E., and H. M. Wegmann. The Effects of Transmeridian and Transequatorial Air Travel on Psychological Well-Being and Performance. Paper in *Chronobiology: Principles and Applications to Shifts in Schedules*, NATO Advanced Study Institutes Series D: Behavioral and Social Sciences, No. 3. Sijthoff & Noordhoff, The Netherlands, 1980, pp. 339-352.
20. Hauty, G. T., and T. Adams. Phase Shifts of the Human Circadian System and Performance Deficit During the Periods of Transition: I. East-West Flight. *Aerosp. Med.*, v. 73, Dec. 1966, pp. 668-684.
21. Coleman, R. M. *Wide Awake at 3:00 A.M.* W. H. Freeman and Co. (New York), 1986, 184 pp.
22. Dirken, J. M. Industrial Shift Work: Decrease in Well-Being and Specific Effects. *Ergonomics*, v. 9, No. 2, 1966, pp. 115-124.
23. Kogi, K. Job Content and Working Time: The Scope for Joint Change. *Ergonomics*, v. 34, No. 6, 1991, pp. 757-773.
24. Volle, M., G. R. Brisson, M. Perusse, M. Tanaka, and Y. Doyon. Compressed Work-Week: Psychophysiological and Physiological Repercussions. *Ergonomics*, v. 22, No. 9, 1979, pp. 1001-1010.
25. Kelly, R., and M. Schneider. The Twelve-Hour Shift Revisited: Recent Trends in the Electric Industry. *J. Hum. Ergology*, v. 11, 1982, pp. 369-384.
26. Tepas, D. T. Flexitime, Compressed Workweeks and Other Alternative Work Schedules. Ch. in *Hours of Work*, ed. by S. Folkard and T. Monk. Wiley, 1985, pp. 147-164.
27. Wilkinson, R., S. Allison, M. Feeney, and Z. Kaminska. Alertness of Night Nurses: Two Shift Systems Compared. *Ergonomics*, v. 32, No. 3, 1989, pp. 281-292.
28. Duchon, J. C., C. M. Keran, and T. J. Smith. Extended Workdays in an Underground Mine—A Work Performance Analysis. *Hum. Factors*, v. 36, in press.
29. Duchon, J. C. Evaluation of Two Work Schedules in a Mining Operation. Paper in *Trends in Ergonomics/Human Factors V*, ed. by F. Aghazadeh. Elsevier, 1988, pp. 151-160.

# NATURE AND COST OF LOW BACK PAIN

By Sean Gallagher<sup>1</sup> and Christopher A. Hamrick<sup>2</sup>

## ABSTRACT

Low back pain (LBP) represents a huge expense to the mining industry and to society as a whole. Any effort to control the problems associated with LBP requires an understanding of the nature of LBP. This review paper was written by the U.S. Bureau of Mines to describe the

current state of knowledge regarding LBP—the causes, risk factors for LBP, effectiveness of treatments, recovery from back pain, and methods that can be used to help control the problem.

## INTRODUCTION

Low back pain (LBP) is very common in Western countries and is a major cause of worker disability, limitation of activity, and economic loss. Many studies have indicated that up to 80% of the general population are affected by LBP at some time during their lives (26, 35).<sup>3</sup> Furthermore, it is estimated that approximately one in seven Americans are currently experiencing LBP (25). The cost of back injuries in the United States in 1989 was variously estimated to be anywhere from \$27 to \$56 billion (38). These costs have undoubtedly risen by a substantial amount since that time.

Few need to be reminded of the magnitude of the back pain problem in the mining industry. Back injuries

consistently rank as the leading cause of lost workdays, account for up to 40% of worker compensation payments, and cost the industry tens of millions of dollars every year (20). In underground coal mines alone, back injuries cost the industry in excess of \$30 million in 1991. The average cost of a back injury that year was over \$8,000.<sup>4</sup> As part of its mission to enhance the safety and efficiency of mining, this review paper was written by the U.S. Bureau of Mines to describe the current state of knowledge regarding LBP—the causes, risk factors for LBP, effectiveness of treatments, recovery from back pain, and methods that can be used to help control the problem.

## CAUSE OF LBP

While a great deal of knowledge has been accumulated regarding LBP in the past couple of decades, doctors and scientists still cannot explain the exact mechanisms causing pain in the majority of patients with LBP. Many experts believe that LBP is caused by changes in the spine as an

individual ages. It is thought that the changes that occur as one gets older may lower the resistance of the spine to heavy workloads. Consequently, heavy loads on the spine trigger the onset of low back symptoms (26-27, 34, 41).

<sup>1</sup>Research physiologist.

<sup>2</sup>Industrial engineer.

Pittsburgh Research Center, U.S. Bureau of Mines, Pittsburgh, PA.

<sup>3</sup>Italic numbers in parentheses refer to items in the list of references at the end of this paper.

<sup>4</sup>Unpublished data prepared by C. A. Hamrick in 1994; available upon request from S. Gallagher, BuMines, Pittsburgh, PA.

## TYPICAL LBP HISTORY

LBP typically begins fairly early in life (usually in one's twenties). Back pain during this period is typified by a mild and diffuse pain of relatively short duration, which is followed by a return to full activity. In one's thirties, there are often more frequent attacks of LBP, which are relieved by rest and followed by relatively pain-free periods. Back pain typically peaks in the forties; episodes of sciatica

(radiating back pain) are more frequent, and there is often residual pain between attacks. Improvement is frequently seen in the fifties. This period is characterized by less severe pain, which appears to be arthritic in nature (morning stiffness) and is largely relieved by activity during the day. The sixties often bring substantial relief from pain for the LBP patient (41).

## BACK INJURY RISK FACTORS

Effective control of LBP requires an understanding of activities that increase the risk of an injury. Some of the major factors associated with increased risk of back pain follow:

- Manual materials handling (especially lifting).
- Twisting of the trunk.
- Bending the trunk forward.
- Bending the trunk to the side.
- Excessive reaching.
- Falls.
- Prolonged sitting.
- Sedentary jobs.
- Highly physical jobs.
- Exposure to whole-body vibration.
- Cigarette smoking.
- Obesity.
- Extreme tallness.

As can be seen, a wide variety of activities are associated with back injuries (from prolonged sitting to heavy lifting). The following sections give some additional detail with regard to these risk factors.

### SPECIFIC RISK FACTORS FOR LBP

*Manual Materials Handling.*—According to a study performed by Bigos (7), manual handling tasks are associated with almost two-thirds of all low back compensation claims. Lifting is a particular concern, being associated with 49% of low back compensation cases (43). Studies have shown that lifting is especially hazardous if the object workers have to lift is excessive, i.e., greater than 15.9 kg (35 lb) in weight (13, 30, 42). Perhaps more important than the actual weight of an object is the moment that is imposed on the low back. Figure 1 illustrates this point by posing the question: Which is more stressful on the low back, 15 kg (33 lb) of feathers or 15 kg (33 lb) of lead? In this example, 15 kg (33 lb) of feathers actually makes the load experienced by the spine greater. This is because the 15 kg (33 lb) of feathers must be packaged in a bulky

container, which causes the worker to hold the object further away from his or her body (creating a larger moment). This increases low back stress. Fifteen kilograms (thirty three pounds) of lead, on the other hand, makes for a compact load that can be carried quite close to the body, which will decrease the stress on the low back. Many other aspects of manually lifting a load have been shown to be potential hazards to the musculoskeletal system. These include horizontal and vertical location of the load, shape and size of the load, lifting frequency, load stability, couplings, duration of lifting, workplace geometry, asymmetric lifting, environmental issues, etc. (21).

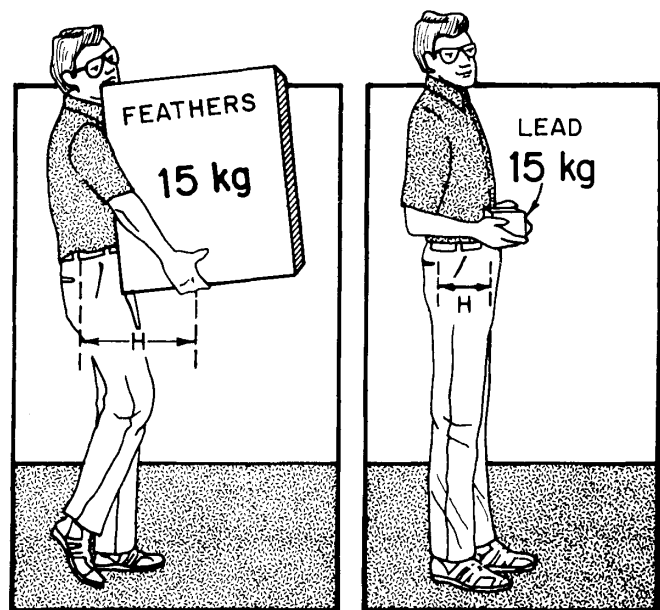

Figure 1.—Fifteen kilograms (thirty-three pounds) of feathers result in increased loading on the spine compared with 15 kg (33 lb) of lead. The lead (being compact) can be held much closer to the body, which decreases the horizontal distance (H) from the low back to the center of gravity of the object. The result is a decreased load on the low back. (Adapted from "UAW-Ford Job Improvement Guide," copyright 1988, Regents of the University of Michigan. Used by permission.)

*Body Motions.*—Twisting of the trunk is associated with a significant proportion of low back compensation cases (approximately 18%). Bending the trunk forward is also associated with such cases, but to a somewhat lesser degree (12% of cases).<sup>5</sup> More recent studies have also shown that the more quickly one twists the trunk or bends the trunk to the side, the higher the back injury risk (32). Other studies have demonstrated that excessive reaching (for example, reaching over obstacles or handling bulky objects) is associated with higher back injury rates (3, 48). Falls are responsible for only about 10% of compensation cases (7), but these cases tend to be somewhat more severe and costly (7, 47).

*Environmental Factors.*—Workers who are required to sit for prolonged periods of time have a higher risk of back pain (31). This may be due in part to the fact that the spine is almost fully bent forward in a relaxed sitting posture (4). It appears that jobs with low physical demands (sedentary jobs) and jobs possessing high physical demands both have somewhat higher incidences of LBP (36). A moderate amount of physical work is related to lowest back injury rates. Exposure to whole-body vibration (such as that experienced by shuttle car drivers) has also been implicated as a risk factor (9, 19). Another environmental factor that has received a great deal of attention recently is that of job satisfaction. Several studies

have recently reported that an employee's satisfaction with his or her job, working environment, and/or first line supervisor is related to LBP (6, 45). One reason for this relationship may be that workers who enjoy their jobs are willing to work through minor bouts of back pain, while persons who do not like their job will use the same type of pain as a chance to get away from an undesirable situation.

*Personal Factors.*—A recent study has demonstrated that smokers have an increased risk of LBP (17). In fact, this study showed a dose-response relationship between cigarette smoking and LBP. What this means is that the more a person smokes, the greater is his or her risk of LBP. The reasons for a smoker's increased LBP risk are probably due to two factors: (1) Smokers develop a deep cough, which places increased stress on the low back, and (2) smoking decreases blood circulation to the spine, which prevents essential nutrients from being delivered, causing tissues to be increasingly vulnerable to injury. Other personal risk factors involve body size. Back pain appears to be about twice as common in the 20% most obese (17). Furthermore, exceptionally tall individuals seem to have a higher incidence of LBP (3). Certain types of LBP (especially those cases involving intervertebral disk problems) seem to have a genetic component, as well (39).

## MULTIPLE RISK FACTORS

Although the exact relationship is not known, it is believed that the various personal and task risk factors listed above interact with one another (21). That is, several risk factors may be present at the same time, which may increase the chances of a worker experiencing a back injury (14). Thus, in a general sense, the greater the number of risk factors an individual has, the greater the likelihood will be that an individual will experience an episode of LBP.

As an example, let's look at a truck driver, whom we'll call Charlie. In his everyday job, Charlie may be exposed to a large number of back injury risk factors. As a truck driver, Charlie typically has to remain seated for prolonged periods of time and is exposed to whole-body vibration when driving. Charlie is a two-pack a day smoker and is also very obese, both of which may increase the likelihood of experiencing LBP. Furthermore, Charlie has to do heavy lifting to unload his truck. In the unloading process, Charlie is forced to bend and twist to get some of the loads off of the truck. One can easily see that Charlie has a large number of risk factors that increase the likelihood that he will experience an injury to his lower back.

Contrast Charlie's situation with that of Frank. Frank works in an office. While he sits at his desk a fair amount of the time, he's often called upon to do other jobs that require him to be up and around the office. Frank is rarely required to do any heavy lifting, but is called upon to do light lifting every so often. Frank is a nonsmoker and takes pride in keeping himself in shape. Compared to Charlie, it should be fairly obvious that Frank has fewer risk factors for LBP and would be less likely to experience an injury. The authors want to make it clear that it is *possible* that Frank might experience a back injury, while Charlie may remain injury-free. However, the *probability* is that we would expect Charlie to be the one to most likely experience bouts of LBP and disability.

Looking at these two cases brings up another point. Let's suppose that both Charlie and Frank are experiencing a moderate amount of back pain. Frank may well be able to go to work and tolerate his LBP and still be able to do his job effectively. However, the same amount of back pain might be disabling for Charlie, because the pain may well prevent him from being able to perform the tasks that are required in his job. So not only does Charlie's job increase the chances that he will experience a back injury, it also increases the chances that his back pain will result in lost time.

<sup>5</sup>Private communication from Stover H. Snook, Liberty Mutual Insurance Co., Aug. 1989.



## TREATMENT OF LBP

### CHOICE AND EFFECTIVENESS OF TREATMENT

The majority of individuals who experience LBP cope with their pain without seeking any sort of medical treatment. While a large number of therapies have been attempted to combat LBP, most studies have demonstrated relatively little difference in the effectiveness of various therapies (49). One therapy that clearly fares worse than others is extended bed rest (49). It is clear that a few days of bed rest may be necessary during episodes of acute LBP; however, it is important that the patient be mobilized as soon as possible.

### MANIPULATION

One difference that was noted in a large, carefully controlled study was that patients who received "chiropractic-type" rotational manipulation of the spine reported more immediate relief than that of the control group. However, over the long run there was no difference in pain relief between those receiving spine manipulation and those who did not (24).

### EXERCISE

There is some support for the use of exercises to decrease the degree of incapacity and increase the mobility of the spine that typically accompanies LBP. Furthermore, endurance training of the back muscles appears to have some benefits in patients with postural LBP. Finally, exercise appears to have a significant effect in decreasing stress, improving the patient's attitude, and allowing better

sleep; exercise may provide a positive alternative to prolonged use of medication in the chronic LBP patient.

### BACK SCHOOLS

Back schools appear to reduce sick leave, improve work status, decrease pain intensity or duration, and increase the activity level of patients. The "self-care" approach taught at back schools generally consists of enhanced knowledge of the anatomy and physiology of the back, better body mechanics and work techniques, and improved muscle strength and flexibility. Back schools have been used for patients with chronic pain, short-term (acute) pain, and as a preventive technique for industrial workers. Of the three groups, back schools appear to provide most help to patients with acute pain.<sup>6</sup>

### SURGERY

Surgery is only helpful in a very small segment (1% to 2%) of back pain cases. Successful surgery is reliant upon careful selection of the patient. The successful surgical patient must have unrelenting sciatica (back pain that radiates down the leg), and even then, only 5% to 10% of such patients should be candidates for surgery. The unfortunate fact is that surgery often only provides short-term benefits to the patient. Comparisons of surgical and nonsurgical patients indicate that surgical patients do somewhat better after 1 year, but after 4 years have passed, surgical and nonsurgical groups fare about the same (18).

## RECOVERY FROM LBP

### RETURN TO WORK

A study of compensation cases in 22 States for 1982 indicated that the average duration of a lost time back injury was 14 scheduled workdays (48). However, data from the U.S. Mine Safety and Health Administration records of mining accidents in 1990 indicated that the average days lost for a back injury was more than three times as long as that mentioned in the previous study (an average of 43 days lost)! Table 1 illustrates the percentage of compensation cases returning to work, by time (44). This table illustrates that almost two-thirds of patients returned to work within 2 weeks and four out of five returned within 6 weeks. However, after 6 weeks, the return to work was much slower. Seven percent of compensation cases lasted longer than 1 year.

Table 1.—Low back compensation cases returning to work, by time (44)

| Week     | Workers returning, % |
|----------|----------------------|
| 1 .....  | 42                   |
| 2 .....  | 62                   |
| 6 .....  | 79                   |
| 12 ..... | 87                   |
| 24 ..... | 89                   |
| 52 ..... | 93                   |

### PROBABILITY OF RETURNING TO WORK

Data show quite clearly that there is a limited time to get workers back on the job once they have experienced a

<sup>6</sup>See footnote 5.

back injury. Table 2 illustrates the probability of a worker returning to active employment after various durations of being off work, based on data collected in two different studies (33, 40). This table shows that if a worker is off 6 months with a back injury, the chances are even that he or she will return to productive employment. If the worker is off for 1 year, there is only a one in four chance that the worker will return to work. But if the worker is off for 2 years, the chances are very slim that the worker will ever return to the active work force.

**Table 2.—Probability of worker returning to work for low back compensation cases, percent**

|                                 | McGill (33) | Rosen (40) |
|---------------------------------|-------------|------------|
| Off work over 6 months . . .    | 50          | 35-55      |
| Off work over 1 year . . . . .  | 25          | 10-25      |
| Off work over 2 years . . . . . | Nil         | 2- 3       |

## CONTROL OF LBP

There are three traditional approaches to the control of back pain that will be considered here. These are (in order of effectiveness) job design (ergonomics), worker selection and job placement, and education and training. These will be discussed briefly below; however, a more extended treatment of job design is given in a companion paper in this proceedings (23).

### JOB DESIGN (ERGONOMICS)

Ergonomics is a science that strives to improve job design so that job or task demands do not exceed the physical capabilities of the worker. This approach has become quite popular in general industry over the past couple of decades, and a scattering of ergonomic committees have been created in the mining industry over the past several years (37). Studies have indicated that the proper design of jobs can reduce up to one-third of all low back compensation by reducing the onset of painful episodes, allowing the worker to stay on the job longer and permitting the worker to return to the job more quickly (43).

The job design approach begins with the evaluation of existing jobs to identify risk factors that may lead to back injury. As identified previously, back injury risk factors may include manual handling tasks; body movements such as bending, twisting, and reaching; excessive loads; prolonged sitting; prolonged work in static postures; and exposure to whole-body vibration. Job redesign consists of reducing the risk factors associated with the job. For example, exposure to excessive loads may be reduced by providing the worker with mechanical aids. Improving the layout of the workplace may also help to reduce

## DETERRENENTS TO RETURNING TO WORK

There are several factors that may act as barriers to the worker returning to work. Malingering by the worker is sometimes observed, but studies generally find that malingering is less prevalent than is generally believed. More likely deterrent factors associated with workers are psychological disability (anxiety and depression associated with chronic pain) (5) or illness behavior (a magnified or abnormal response to illness) (50-51). Management may also prevent an early return to work through policies that it may put in place. Often management does not provide followup or encouragement for the injured worker. Providing modified, alternative, or part-time work to an injured employee may help facilitate his or her early return (16). Other deterrents to a quick return to work may include specific contract rules, extended treatment by the medical practitioner (15), or situations where legal proceedings result.

unnecessary bending and twisting. Appropriate packaging of objects (to ensure that object weights match worker capabilities) will also reduce exposure to excessive loads. In addition, proper seat design (providing an adjustable seat with good lumbar support and vibration damping) can reduce the stress on the low back (28, 46).

Management is sometimes reluctant to redesign jobs because of the costs involved. However, many companies have learned that devoting capital to job redesign is indeed a sound business investment.<sup>7</sup> Reduced compensation costs and increases in worker productivity will return the cost of the initial investment over time. Determining the payback period will help persuade management of the cost effectiveness of redesigning jobs.

## WORKER SELECTION AND JOB PLACEMENT

### Medical Examination

It has been estimated that a maximum of 1 in 12 young (first hire age) workers susceptible to low back problems may be identified by performing a careful examination and obtaining a thorough medical history (41). The effectiveness of this approach for older workers may be somewhat higher (41). However, it should be pointed out that there is no guarantee that the workers screened out through this process will ever experience a bout of LBP. Use of X-rays in the examination process has been controversial, with the majority of physicians recommending that routine pre-placement X-rays not be used (2).

<sup>7</sup>See footnote 5.

### Strength and Fitness Testing

Studies have indicated that the chance of a musculo-skeletal injury is up to three times higher when the lifting requirements of a job approach or exceed a worker's isometric lifting capacity (12, 29). However, it is important to note that if strength testing is used to place workers in jobs, there is a risk of possible legal problems involving discriminatory hiring practices. To prevent such accusations, it is crucial that the strength tests used to select workers match the job demands as closely as possible.

In recent years, a large number of sophisticated strength testing devices have appeared on the market. However, thus far, there are no data regarding the effectiveness of these devices in reducing LBP.

## EDUCATION AND TRAINING

### Training in Safe Lifting

Teaching workers the proper method of lifting would appear to be a useful way to prevent back problems. However, the studies examining the effectiveness of this approach have failed to demonstrate that training has any effect on LBP (8, 15, 43, 52). There may be several reasons why these studies have shown no effect. For one thing, the quality of training in industry is typically lacking. Presentations are generally poor, the content of programs uneven, and there is usually no followup associated with training programs. Furthermore, workers tend not to comply with safe lifting recommendations, unless a program of performance feedback is provided (1). Safe lifting is not a natural way to lift, requires more energy to perform, and is generally harder to do (22). Uninjured workers are particularly hard to motivate. A better approach

may be to concentrate training efforts on workers with a history of LBP, rather than attempting to train the entire work force.

### Strength and Fitness Training

Some research appears to support the notion that improving worker fitness decreases the chances of worker compensation claims (10). Table 3 shows the results of a study examining the fitness of 1,652 Los Angeles firefighters. The firefighters were divided into three fitness categories based on strength, flexibility, heart rate and blood pressure, and physical work capacity. This study demonstrated that the most fit workers had fewer back-related compensation claims, the least fit had the highest number of claims, and those in between had a moderate number of claims. In a separate study (11), compensation costs were compared between workers with the greatest and least flexibility, strength, and physical work capacity. This study showed that workers with the greatest flexibility, strength, and work capacity had much lower compensation costs compared to those with the least flexibility, strength, and work capacity. The authors concluded that physical fitness and conditioning may have some preventive effect with regard to back disorders.

Table 3.—Low back compensation claims for Los Angeles firefighters, by level of fitness (10)

|  | Most<br>fit | Middle<br>fit | Least<br>fit |
|--|-------------|---------------|--------------|
| Number of firefighters . . . . .       | 266         | 1,127         | 259          |
| Low back compensation claims . . % . . | 0.77        | 3.19          | 7.14         |

## SUMMARY

The economic costs of LBP are overshadowed only by the pain and disability experienced by the sufferer. Despite significant advances in knowledge of the low back, the exact causes of LBP remain largely unknown. We do know that there are several risk factors that increase the chances of experiencing LBP. These include lifting, bending and twisting of the trunk, prolonged sitting, exposure to whole-body vibration, and smoking. The best methods for controlling LBP in the workplace is to reduce the worker's exposure to these risk factors. If a back

injury does occur, there is a limited amount of time to get the worker back on the job. The longer the worker is off the job, the greater the chances are that the worker will not return. Three main approaches have been used to control LBP: job design (ergonomics), worker selection and job placement, and education and training. Of these, job design appears to offer the greatest ability to reduce the occurrence of LBP; however, most effective back injury control efforts use a combination of the approaches listed above.

## REFERENCES

1. Alavosious, M. P., and B. Sulzer-Azaroff. The Effects of Performance Feedback on the Safety of Client Lifting and Transfer. *J. Appl. Behav. Anal.*, v. 19, 1986, pp. 261-267.

2. American Occupational Medical Association. Guidelines for Use of Routine X-ray Examinations in Occupational Medicine. *J. Occup. Med.*, v. 21, 1979, pp. 500-502.

3. Andersson, G. B. J. Epidemiologic Aspects of LBP in Industry. *Spine*, v. 6, 1981, pp. 53-60.
4. \_\_\_\_\_. Measurement of Loads on the Lumbar Spine. Paper in Symposium on Idiopathic Low Back Pain. C. V. Mosby Co., St. Louis, MO, 1982, pp. 220-251.
5. Beals, R. K., and N. W. Hickman. Industrial Injuries of the Back and Extremities. *J. Bone and Jt. Surg.*, v. 51A, 1972, pp. 1593-1611.
6. Bigos, S. J., D. M. Spengler, N. A. Martin, J. Zeh, L. Fisher, and A. Nachemson. Back Injuries in Industry: A Retrospective Study. III. Employee-Related Factors. *Spine*, v. 11, 1986, pp. 252-256.
7. Bigos, S. J., D. M. Spengler, N. A. Martin, J. Zeh, L. Fisher, A. Nachemson, and M. H. Wang. Back Injuries in Industry: A Retrospective Study. II. Injury Factors. *Spine*, v. 11, 1986, pp. 246-251.
8. Brown, J. Lifting as an Industrial Hazard. *Am. Ind. Hyg. Assoc. J.*, v. 34, 1973, pp. 292-297.
9. Burton, A. K., and J. Sandover. Back Pain in Grand Prix Drivers: A Found Experiment. *Appl. Ergon.*, v. 18, 1987, pp. 3-8.
10. Cady, L. D., D. P. Bischoff, E. R. O'Connell, P. C. Thomas, and J. H. Allen. Strength and Fitness and Subsequent Back Injuries in Firefighters. *J. Occup. Med.*, v. 21, 1979, pp. 269-272.
11. Cady, L. D., P. C. Thomas, and R. J. Karwasky. Program for Increasing Health and Physical Fitness of Firefighters. *J. Occup. Med.*, v. 27, 1985, pp. 110-114.
12. Chaffin, D. B. Human Strength Capability and LBP. *J. Occup. Med.*, v. 16, 1974, pp. 248-254.
13. Chaffin, D. B., and K. S. Park. A Longitudinal Study of Low-Back Pain as Associated With Occupational Weight Lifting Factors. *Am. Ind. Hyg. Assoc. J.*, v. 34, 1973, pp. 513-525.
14. Dehlin, O., and S. Berg. Back Symptoms and Psychological Perception of Work: A Study Among Nursing Aides in a Geriatric Hospital. *Scand. J. Rehabil. Med.*, v. 9, 1977, pp. 61-67.
15. Dehlin, O., B. Hedenrud, J. Horal. Back Symptoms in Nursing Aides in a Geriatric Hospital. *Scand. J. Rehabil. Med.*, v. 8, 1976, pp. 47-53.
16. Derebery, V. J., and W. H. Tullis. Delayed Recovery in the Patient With a Work Compensable Injury. *J. Occup. Med.*, v. 25, 1983, pp. 829-835.
17. Deyo, R. A., and J. E. Bass. Lifestyle and LBP: The Influence of Smoking and Obesity. *Spine*, v. 14, 1989, pp. 501-506.
18. Frymoyer, J. W. Back Pain and Sciatica. *N. Engl. J. Med.*, v. 318, 1988, pp. 291-300.
19. Frymoyer, J. W., M. H. Pope, J. H. Clements, D. G. Wilder, B. McPherson, and T. Ashikaga. Risk Factors in LBP. *J. Bone and Jt. Surg.*, v. 65A, 1988, pp. 213-218.
20. Gallagher, S., T. G. Bobick, and R. L. Unger. Reducing Back Injuries in Low-Coal Mines: Redesign of Materials-Handling Tasks. *BuMines IC 9235*, 1990, 33 pp.
21. Garg, A. Epidemiological Basis for Manual Lifting Guidelines. Paper in Scientific Support Documentation for the Revised 1991 NIOSH Lifting Equation: Technical Contract Reports. NIOSH, Washington, DC, 1991, 58 pp.
22. Garg, A., and G. D. Herrin. Stoop or Squat: A Biomechanical and Metabolic Evaluation. *Am. Inst. Ind. Eng. Trans.*, v. 11, 1979, pp. 293-302.
23. Hamrick, C. A., and S. Gallagher. Job Design: An Effective Strategy for Reducing Back Injuries. Paper in this proceedings.
24. Hoehler, F. K., J. S. Tobis, and A. A. Buerger. Spinal Manipulation for LBP. *J. Am. Med. Assoc.*, v. 245, 1981, pp. 1835-1838.
25. Holbrook, T. L., K. Grazier, J. L. Kelsey, and R. N. Stauffer. The Frequency of Occurrence, Impact and Cost of Selected Musculoskeletal Conditions in the United States. *Am. Acad. Orthop. Surg.*, 1984.
26. Hult, L. Cervical, Dorsal, and Lumbar Spine Syndrome. *Acta Orthop. Scand. Suppl.*, No. 17, 1954, pp. 1-102.
27. Jayson, M. I. V. Back Pain: Some New Approaches. *Med. J. Aust.*, v. 1, 1979, pp. 513-516.
28. Kelsey, J. L., P. B. Githens, T. O'Connor, U. Weil, J. A. Calogero, T. R. Holford, A. A. White, S. D. Walter, A. M. Ostfeld, and W. O. Southwick. Acute Prolapsed Lumbar Intervertebral Disc: An Epidemiologic Study With Special Reference to Driving Automobiles and Cigarette Smoking. *Spine*, v. 9, 1984, pp. 608-613.
29. Keyserling, W. M., G. D. Herrin, and D. B. Chaffin. Isometric Strength Testing as a Means of Controlling Medical Incidents on Strenuous Jobs. *J. Occup. Med.*, v. 22, 1980, pp. 332-336.
30. Liles, D. H., S. Deivanyagam, M. M. Ayoub, and P. Mahajan. A Job Severity Index for the Evaluation and Control of Lifting Injury. *Hum. Factors*, v. 26, 1984, pp. 683-693.
31. Magora, A. Investigation of the Relation Between LBP and Occupation. 3. Physical Requirements: Sitting, Standing, and Weight Lifting. *Ind. Med. and Surg.*, v. 41, 1972, pp. 5-9.
32. Marras, W. S., S. A. Lavender, S. E. Leurgans, S. L. Rajulu, W. G. Allread, F. A. Fatallah, and S. A. Ferguson. The Role of Dynamic Three-Dimensional Trunk Motion in Occupationally-Related Low Back Disorders: The Effects of Workplace Factors, Trunk Position, and Trunk Motion Characteristics on Risk of Injury. *Spine*, v. 18, 1993, pp. 617-628.
33. McGill, C. M. Industrial Back Problems: A Control Program. *J. Occup. Med.*, v. 10, 1968, pp. 174-178.
34. Nachemson, A. L. Editorial Comment: Lumbar Discography—Where Are We Today? *Spine*, v. 14, 1989, pp. 555-557.
35. \_\_\_\_\_. The Lumbar Spine: An Orthopaedic Challenge. *Spine*, v. 1, 1976, pp. 59-71.
36. Nordin, M. Workplace Evaluation and Design. Pres. at the Tenth Annual Occupational LBP Conference, Long Beach, CA, Oct. 18-21, 1989; available upon request from S. Gallagher, BuMines, Pittsburgh, PA.
37. O'Green, J., R. H. Peters, and A. B. Cecala. AEP Fuel Supply's Ergonomic Approach to Reducing Back Injuries. Paper in Proceedings of the Twenty-Third Annual Institute on Mining Health, Safety and Research (Blacksburg, VA, Aug. 24-26, 1992). VA Polytech. Inst. and State Univ., Blacksburg, VA, 1992, pp. 187-195.
38. Pope, M. H., G. B. J. Andersson, J. W. Frymoyer, and D. B. Chaffin. Occupational LBP: Assessment, Treatment and Prevention. *Mosby Year Book*, St. Louis, MO, 1991, pp. 95-113.
39. Postacchini, F., R. Lami, and O. Pugliese. Familial Predisposition to Discogenic Low-Back Pain. *Spine*, v. 13, 1988, pp. 1403-1406.
40. Rosen, N. B. Treating the Many Facets of Pain. *Bus. and Health*, May 1986, pp. 7-10.
41. Rowe, M. L. Backache at Work. Perinton Press, Fairport, NY, 1983, pp. 94-101.
42. Snook, S. H. The Design of Manual Handling Tasks. *Ergonomics*, v. 21, 1978, pp. 963-985.
43. Snook, S. H., R. A. Campanelli, and J. W. Hart. A Study of Three Preventive Approaches to Low Back Injury. *J. Occup. Med.*, v. 20, 1978, pp. 478-481.
44. Snook, S. H., and B. Webster (Liberty Mutual Insur. Co., Hopkinton, MA). Unpublished data, 1987; available upon request from S. Gallagher, BuMines, Pittsburgh, PA.
45. Svensson, H., and G. B. J. Andersson. The Relationship of Low-Back Pain, Work History, Work Environment, and Stress. *Spine*, v. 14, 1989, pp. 517-522.
46. Troup, J. D. G. Driver's Back Pain and Its Prevention. *Appl. Ergon.*, v. 9, 1978, pp. 207-213.
47. Troup, J. D. G., J. W. Martin, and D. C. E. F. Lloyd. Physical Exercise in the Treatment of LBP. *Orthop. Rev.*, v. 17, 1988, pp. 724-729.
48. U.S. Bureau of Labor Statistics (Dep. Labor). Back Injuries Associated With Lifting. *Bull.* 2144, Aug. 1982.
49. Waddell, G. A New Clinical Model for the Treatment of Low-Back Pain. *Spine*, v. 12, 1987, pp. 632-644.
50. Waddell, G., C. J. Main, E. W. Morris, M. DiPaola, and I. C. M. Gray. Chronic Low-Back Pain, Psychologic Distress, and Illness Behavior. *Spine*, v. 9, 1984, pp. 209-213.
51. Waddell, G., J. A. McCulloch, E. Kummel, and R. M. Venner. Nonorganic Physical Signs in Low-Back Pain. *Spine*, v. 5, 1980, pp. 117-125.
52. Wood, D. J. Design and Evaluation of a Back Injury Prevention Program Within a Geriatric Hospital. *Spine*, v. 12, 1987, pp. 77-82.

# A SCIENTIFIC LOOK AT BACK BELTS

By Sean Gallagher<sup>1</sup> and Christopher A. Hamrick<sup>2</sup>

## ABSTRACT

In recent years there has been a tremendous increase in the use of back belts by companies attempting to control back injury costs. Many claims have been made regarding the effectiveness of back belts; however, not many

of these have been based on sound scientific evidence. In fact, there is contradictory information on the value of back belts. The U.S. Bureau of Mines reviewed literature relating to the effectiveness of back belts in the workplace.

## INTRODUCTION

A tremendous increase in the use of back belts by companies attempting to control back injury costs has been seen in recent years. Numerous belt designs are being made available to industry, based on the premise that they reduce the risk of low back pain. Many claims have been made regarding the effectiveness of back belts; however, not many of these have been based on sound scientific evidence. In fact, there is contradictory information on the value of back belts. Some studies have supported the use of belts, while others have suggested that workers would be better advised to refrain from their use. As part of its program to enhance safety for the underground mine

worker, the U.S. Bureau of Mines (USBM) has reviewed evidence relating to the effectiveness of back belts and provided some suggestions relating to the use of back belts in the workplace. This paper is largely based on a review of back belt literature by the noted spinal biomechanist S. M. McGill (11).<sup>3</sup>

There are several potential benefits and drawbacks associated with wearing back belts that should be considered before a responsible policy can be established. Let us first examine the hypothesized benefits associated with back belt usage and the related scientific evidence.

## POTENTIAL BENEFITS OF BACK BELTS

The following list details the major benefits that might be provided by back belts:

1. Decrease the load experienced by the low back.
2. Help to "stiffen" the spine to make it stronger.
3. Restrict spine mobility and prevent hazardous movements.

4. Provide a safety margin by increasing an individual's tolerance to heavy loads.

5. Decrease back injury incidence when used in industrial settings.

The following sections will address the scientific evidence related to these hypothesized benefits.

<sup>1</sup>Research physiologist.

<sup>2</sup>Industrial engineer.

Pittsburgh Research Center, U.S. Bureau of Mines, Pittsburgh, PA.

<sup>3</sup>Italic numbers in parentheses refer to items in the list of references at the end of this paper.

### **Do back belts decrease the load experienced by the low back?**

One of our best methods for establishing the answer to this question is to examine muscle activity. If back belts decrease the load on the low back, we would expect to see a decrease in the electrical activity of the powerful back muscles. However, studies have convincingly shown that there is no difference in back muscle activity when wearing a belt compared with not wearing one (8, 13). Thus, back belts do not appear to lessen the load experienced by muscles of the lumbar spine (low back).

Some have hypothesized that back belts help to reduce the load on the low back by increasing intra-abdominal pressure (IAP). Indeed, lifting while wearing a belt does appear to increase IAP (5, 9). Years ago, higher IAP was thought to be beneficial by adding supporting forces to the low back (3, 14). However, recent data have caused this theory to be reevaluated (12, 16). It now appears that increased IAP has little, if any, effect that would decrease the load on the spine.

### **Do back belts help to stiffen the spine (make it stronger)?**

While it is generally believed that increased IAP does not reduce the spinal load, the possibility exists that higher IAP may assist the low back by increasing the stiffness of the spine. Unfortunately, this is a difficult claim to test scientifically. Current thinking is that even if higher IAP does provide some additional stiffness, the advantage gained is probably fairly small (13, 19). Thus, at the present time, most back injury experts feel that the justification for wearing belts based on increased IAP is probably not warranted.

### **Do back belts restrict spine mobility and hazardous movements?**

There is evidence to suggest that certain types of belts restrict the amount of side-to-side bending and trunk twisting that a worker can perform (19). This may be in part responsible for the reported perception of increased stability of the trunk by wearers. However, belts currently available do not appear to restrict forward bending of the lumbar spine. This appears to be an important exception, because of the fact that the strength of the spine and its ability to tolerate loads are considerably lower when the worker is in a forward bent position (1). Furthermore, this posture is associated with increased risk of back injury (15). Therefore, while the reduction in side bending and twisting is viewed as generally positive, the fact that current belts do not restrict forward bending means that back belts still allow individuals to subject their spines to hazardous postures.

### **Do back belts improve an individual's load tolerance?**

One possible benefit of back belts is that they might provide a "safety margin" by increasing the tolerance of individuals to heavy loads. However, data from recent studies have indicated that wearing a back belt does not increase an individual's ability to sustain additional loads in forward bending, side bending, or twisting (19). Thus, it does not appear that belts provide an additional safety margin by increasing a worker's tolerance to heavy loads.

### **Does use of back belts in industry decrease the incidence of back injuries?**

Several recent studies have been performed that attempted to determine whether belts actually do reduce the incidence of injury (2, 6, 18, 20). Unfortunately, the studies performed thus far have been of widely varying quality. Only two back belt studies have been performed that use the method that provides the highest quality data (i.e., prospective studies using matched control groups). These studies were performed by Reddell (18) and Walsh (20).

The Walsh (20) study is the one pointed to most frequently by back belt proponents as evidence of the effectiveness of back belts. The investigators studied 81 workers in an industrial warehouse setting. Results of this study did, in fact, demonstrate a reduction in lost-time back injuries due to use of back belts, but careful scrutiny of the data indicates that the benefit was found *only* among workers who had experienced previous back injuries. No benefit was observed for previously uninjured employees.

The second of these studies examined the effectiveness of back belts, in which 642 airline baggage handlers were observed (18). These researchers found no differences in back injury incidence rates between groups using back belts and those not using belts. However, these researchers did discover a disturbing trend. Workers who started the study wearing back belts and dropped out (discontinued use of the belts) had a higher incidence of back injury than any other group. The researchers in this study concluded that back belt use may cause some physical dependency, leaving the back at increased risk when the device is withdrawn.

It is important to note that neither of the studies (18, 20) demonstrated that belt use had any benefits for uninjured workers. However, it is noteworthy that belts did seem to help workers who had experienced prior back injuries. This indicates that belts may have some usefulness in the workplace under certain circumstances.

## POTENTIAL DRAWBACKS OF BACK BELTS

The following arguments are typical of back belt detractors:

1. Back belts may lead to weakened back muscles (muscle atrophy).
2. Back belt use causes workers to develop a "false sense of security."
3. Increased IAP observed during back belt use may result in adverse physiological changes.

Let us examine the evidence with regard to these issues.

### Do back belts cause back muscles to become weaker (atrophy)?

Several studies have examined this issue, and all of these studies seem to agree that back belts do not lead to a decrease in muscle strength, at least over the short term. This is consistent with the observation that back muscle activity is not decreased with belt use, as mentioned above. However, a recent Swedish study suggested that while back belt use does not result in loss of strength, muscular endurance may be decreased with prolonged belt use (6).

### Do back belts create a false sense of security?

There is some evidence that belts may lead to a false sense of security in workers. As noted above, lifting belts

does not appear to increase an individual's load tolerance. However, studies have indicated that workers are willing to lift up to 20% more weight when wearing a belt (10). Thus, it appears that workers who use belts appear willing to place higher strain on the back and, in fact, are willing to work at a higher percentage of their maximum load tolerance. Therefore, workers who wear belts may be working with a decreased safety margin with regard to the low back.

### Do back belts result in adverse physiological changes?

Back belts do seem to cause certain unwanted physiological changes to occur. The most significant of these is the increase in blood pressure that has been observed when lifting using a belt. Blood pressure has been shown to be elevated almost 15 mm Hg when lifting with a belt (7). Any individuals with a history of heart problems or those with significant cardiovascular risk factors should consult a physician prior to donning a back belt. An increase in blood pressure by 15 mm Hg may lead to serious health problems among those with a history of cardiovascular problems.

## SUMMARY AND RECOMMENDATIONS

The foregoing information indicates a somewhat mixed bag of evidence—some in support of back belts and some in opposition. Evidence supporting use of back belts includes some restriction in end-range motion of twisting and side bending, clinical evidence of a decrease in lost-time back injuries among those with prior back injuries, and a suggestion of increased trunk stiffness that may be of some benefit. Evidence in opposition of back belt use includes an increased risk of injury upon discontinuing belt use, increased blood pressure, and a false sense of security that may lead workers to overstrain their backs.

This review of the literature indicates that the following approach to use of back belts should be followed (11):

1. **Back belts should be treated as a prescription item** and should be provided only to individuals having had a previous back injury. These workers should be weaned from the belts as soon as it is appropriate.
2. **Back belts should *not* be universally distributed to all workers at a worksite**, given the lack of demonstrated

effectiveness among uninjured workers and a potential increased risk of injury after discontinuation of use.

3. **Individuals considered for a back belt prescription should be screened for cardiovascular risk** because of the increased blood pressure associated with belt use.

4. **Individuals using back belts should be required to participate in a mandatory exercise program** and should continue in the program after being weaned from the belt during the period of increased back injury risk.

5. **Workers using back belts should be exposed to a mandatory education program** to ensure that the back belts are used properly.

6. **A full ergonomic assessment of the workplace should be performed** to reduce any physical hazards that may increase the incidence of back injuries.

The evidence presented in this paper suggests that back belts have a rather limited role to play in controlling the costs and incidence of back injuries. Reliance on back belts as a sole method of combatting this problem clearly

does not provide an effective solution. Effective back injury control programs tend to emphasize job redesign, where the worker's job is changed to reduce the amount of manual lifting that has to be done (or the lifting that must be done is made easier) (17). Methods of job redesign applicable to the mining industry are contained in

the USBM Information Circular 9235 (4). Employers who are interested in keeping the cost of back injuries down are encouraged to focus on job design as a primary method of injury control, and if back belts are to be used, careful consideration should be given to the factors discussed above.

## REFERENCES

1. Adams, M. A., and W. C. Hutton. Mechanics of the Intervertebral Disk. Ch. in *The Biology of the Intervertebral Disc*, ed. by P. Ghosh. CRC Press, 1988, v. 2, pp. 39-72.
2. Asundi, P., J. L. Purswell, and D. Bowen. Evaluation of Back Belts in the Prevention of Manual Material Handling Injuries. Presented at Low Back Injury Symp., Columbus, OH, Apr. 14-15, 1993; available from S. Gallagher, BuMines, Pittsburgh, PA.
3. Bartclink, D. L. The Role of Abdominal Pressure in Relieving the Pressure on Lumbar Intervertebral Discs. *J. Bone Jt. Surg.*, 1957, v. 39B, pp. 718-725.
4. Gallagher, S., T. G. Bobick, and R. L. Unger. Reducing Back Injuries in Low-Coal Mines: Redesign of Materials-Handling Tasks. BuMines IC 9235, 1990, 33 pp.
5. Harman, E. A., R. M. Rosenstein, P. N. Frykman, and G. A. Nigro. Effects of a Belt on Intra-Abdominal Pressure During Weight Lifting. *Med. and Sci. Sports and Exercise*, v. 21, No. 2, 1989, pp. 186-190.
6. Holmstrom, E., and U. Moritz. Effects of Lumbar Belts on Trunk Muscle Strength and Endurance: A Follow-up Study of Construction Workers. *J. Spinal Disorders*, v. 5, No. 3, 1992, pp. 260-266.
7. Hunter, G. R., J. McGuirk, N. Mitrano, P. Pearman, B. Thomas, and R. Arrington. The Effects of a Weight Training Belt on Blood Pressure During Exercise. *J. Appl. Sport Sci. Res.*, v. 3, No. 1, 1989, pp. 13-18.
8. Krag, M. H., K. B. Byrne, L. G. Gilbertson, and L. D. Haugh. Failure of Intra-Abdominal Pressure To Reduce Erector Spinae Loads During Lifting Tasks. Pres. at the N. Am. Congr. on Biomech., Montreal, Canada, 1986, pp. 87-88; available from S. Gallagher, BuMines, Pittsburgh, PA.
9. Lander, J. E., R. L. Simonton, and J. K. F. Giacobbe. The Effectiveness of Weight-Belts During the Squat Exercise. *Med. and Sci. Sports and Exercise*, v. 22, No. 1, 1990, pp. 117-124.
10. McCoy, M. A., J. J. Congleton, W. L. Johnston, and B. J. Jiang. The Role of Lifting Belts in Manual Lifting. *Int. J. Ind. Ergon.*, v. 2, No. 4, 1988, pp. 259-266.
11. McGill, S. M. Biomechanics and Lifting Belts. Pres. at Low Back Injury Symp., Columbus, OH, Apr. 14-15, 1993; available from S. Gallagher, BuMines, Pittsburgh, PA.
12. McGill, S. M., and R. W. Norman. Reassessment of the Role of Intra-Abdominal Pressure in Spinal Compression. *Ergonomics*, v. 30, No. 11, 1987, pp. 1565-1588.
13. McGill, S. M., R. W. Norman, and M. T. Sharratt. The Effects of an Abdominal Belt on Trunk Muscle Activity and Intra-Abdominal Pressure During Squat Lifts. *Ergonomics*, v. 33, No. 2, 1990, pp. 147-160.
14. Morris, J. M., D. B. Lucas, and B. Bresler. Role of the Trunk in Stability of the Spine. *J. Bone Jt. Surg.*, v. 43A, 1961, pp. 327-351.
15. Mundt, D. J., J. L. Kelsey, A. L. Golden, H. Pastides, A. T. Berg, J. Sklar, T. Hosea, and M. M. Panjabi. An Epidemiologic Study of Non-Occupational Lifting as a Risk Factor for Herniated Lumbar Intervertebral Disc. *Spine*, v. 18, No. 5, 1993, pp. 595-602.
16. Nachemson, A., G. B. J. Andersson, and A. B. Schultz. Valsalva Maneuver Biomechanics: Effects on Lumbar Trunk Loads of Elevated Intra-Abdominal Pressure. *Spine*, v. 11, No. 5, 1986, pp. 476-479.
17. O'Green, J. E., R. H. Peters, and A. B. Cecala. AEP Fuel Supply's Ergonomic Approach to Reducing Back Injuries. Pres. at the 23rd Annu. Inst. Min. Health, Saf. and Res., Blacksburg, VA, 1992, pp. 187-196; available from S. Gallagher, BuMines, Pittsburgh, PA.
18. Reddell, C. R., J. J. Congleton, R. D. Hutchingson, and J. F. Montgomery. An Evaluation of a Weightlifting Belt and Back Injury Prevention Training Class for Airline Baggage Handlers. *Appl. Ergon.*, v. 23, No. 5, 1992, pp. 319-329.
19. Seguin, J., and S. M. McGill. The Effects of Abdominal Belts on Passive Stiffness of the Trunk About Three Axes. Pres. at Hum. Factors Assoc. Canada 25th Annu. Conf., Hamilton, Ontario, Canada, 1992, pp. 67-72; available from S. Gallagher, BuMines, Pittsburgh, PA.
20. Walsh, N. E., and R. K. Schwartz. The Influence of Prophylactic Orthoses on Abdominal Strength and Low Back Injury in the Workplace. *Am. J. Phys. Med. & Rehab.*, v. 69, No. 5, 1990, pp. 245-250.



# JOB DESIGN: AN EFFECTIVE STRATEGY FOR REDUCING BACK INJURIES

By Christopher A. Hamrick<sup>1</sup> and Sean Gallagher<sup>2</sup>

---

## ABSTRACT

The U.S. Bureau of Mines conducted research to reduce musculoskeletal injuries. Occupationally related musculoskeletal injuries pose a significant problem to the mining industry. Ergonomics can help to reduce the costs associated with these injuries. Mines can institute committees to solve ergonomic problems. These committees should include representatives from management, the labor force, and the medical department. Various analysis techniques, such as job safety analysis, task analyses, materials-handling flowcharts, and preliminary hazards analysis can be used to identify ergonomic problems in and around a mine.

Once hazards have been identified, then solutions can be formulated and implemented. The preferred strategy

is to redesign the job by eliminating the hazard, removing the worker from exposure, or mechanizing the task. If these strategies are infeasible, then the job should be designed so that it can be performed within the workers' capabilities. After any ergonomic solution is implemented, a followup analysis should be performed to ensure the effectiveness of the change and to guard against the introduction of any new ergonomic or safety hazards. Physical fitness programs and training can be used to supplement job redesign. By effectively instituting sound ergonomic implementation strategies, the costs associated with musculoskeletal disorders can be reduced.

## INTRODUCTION

The U.S. Bureau of Mines (USBM) has undertaken research to reduce musculoskeletal injuries as part of its mission to improve the health and safety of the Nation's miners. Given the unique hazards in mining such as cramped work spaces, rocky and uneven walking surfaces, walking surfaces covered with water, hot and cold temperatures, low levels of lighting, and rough terrain over which heavy vehicles operate (12),<sup>3</sup> one would expect that musculoskeletal injuries are a major portion of all injuries in mining. According to an analysis of all underground coal mining accidents from the 1991 U.S. Mine Safety and Health Administration (MSHA) accident database, 34% were classified as sprains or strains, 21% occurred to the

back, 24% were due to "overexertion," and 24% involved the handling of materials.

In addition to the pain and human suffering created by these injuries, they result in a significant amount of lost time and, hence, lost productivity and contribute to high health care and compensation costs. In fact, Plummer, (14) reported that back injuries alone account for close to 20% of all payroll dollars. According to an informal USBM analysis, in 1991 the average coal mining back injury cost over \$8,400 and the total cost to society for coal mining back injuries was over \$30 million.

Many musculoskeletal injuries are a result of cumulative trauma, or wear and tear that occurs over a relatively long period of time (8). One science that deals with the reduction of such injuries is ergonomics, the study of how human beings relate to their work environment. By using ergonomics, the occurrence of musculoskeletal disorders in the workplace can be reduced. One approach that has

---

<sup>1</sup>Industrial engineer.

<sup>2</sup>Research physiologist.

Pittsburgh Research Center, U.S. Bureau of Mines, Pittsburgh, PA.

<sup>3</sup>Italic numbers in parentheses refer to items in the list of references at the end of this paper.

been successfully used by the general industry, and the mining industry as well, to combat musculoskeletal injuries is to establish an ergonomics committee. O'Green (13) reported a 41% reduction in back injuries over a 4-year

period after the establishment of ergonomics committees at the mine sites studied. These ergonomics committees can form the basis of a successful ergonomics program.

## ERGONOMICS COMMITTEES

The implementation of a successful ergonomics program into the workplace usually requires a multidisciplinary approach. A number of individuals from throughout the mining company should participate. A team approach should be used where a committee is established to provide a forum for the exchange of ideas and the execution of strategies to solve ergonomic problems.

Effective committees should include management, labor, engineering, maintenance, personnel, and front-line employees; furthermore, support from each of these groups must be secured. In addition, the mine medical personnel and the safety specialist or corporate ergonomist should take part. Educating those involved is of utmost importance. According to Pope (16), it is crucial that all personnel be informed about "methods, goals, risk factors, and the possibility of prevention." Small mine operators may not have access to all of these personnel, but the committee should be comprised of as many of the above as is feasible.

Including representatives from the front-line work force is a key element to the success of an ergonomics

committee. Imada (10) outlines three reasons workers should be included in the ergonomic problem-solving process. He states that the workers are already aware of ergonomic principles and ergonomics simply provides labels for ideas already in use. Second, he reports that the likelihood of successful implementation of ergonomics is increased if the worker has some ownership in the ideas. Finally, Imada asserts that by the end-user implementing the technology, he or she "will be able to modify it to solve future problems," thus providing long-term benefits.

Often times, the mine management must be sold on the idea of using ergonomic intervention strategies. A particularly good argument for the use of these strategies can be made through a cost-benefit analysis (15). When performing such an analysis, one must include both direct and indirect (or hidden) costs. Direct costs include such items as medical expenses, worker compensation, and liability costs. Indirect costs often outweigh direct costs and include such items as lost productivity, cost of rehiring and retraining a new employee, and loss of employee morale (5).

## IDENTIFYING PROBLEMS

After the infrastructure is in place and support is secured, the next task is to identify ergonomic problems through various analysis techniques. These analyses can vary in sophistication from informal conversations with employees to more formal techniques, such as job safety analyses. An excellent place to start identifying ergonomic problems is by examining the company safety records. By making a table of incidence rates by job classification, activity at the time of the occurrence, type of injury, etc., one can identify particular jobs or activities that contribute to the most musculoskeletal injuries. One must keep in mind, however, that musculoskeletal injuries are often a result of cumulative trauma; so assigning a single cause to a particular claim may be erroneous in many cases.

After the records are examined, the committee can then rank the jobs and the activities that need to be examined. Prime candidates for job redesign are those jobs that have a particularly high frequency of injury or those activities that result in particularly severe trauma. The jobs should be ranked by the committee and the jobs with the most severe ergonomic problems should be analyzed first.

Task analyses can then be performed so that ergonomic hazards associated with a particular job or task are identified. These analyses usually involve describing in detail each motion or action required to execute a task. By closely examining each motion or action, the ergonomic stressors or the risk factors associated with a job can then be identified. Andersson (1) outlines the following work attributes as risk factors for low-back pain: heavy physical work, static (not moving) work postures, frequent bending and twisting, lifting and forceful movements, repetitive work, and vibration.

One particular type of task analysis, job safety analysis, has recently received much attention in the mining industry and is ideally suited for identifying and correcting ergonomic hazards. MSHA (20) has developed a set of guidelines that detail the job safety analysis process for the mining industry. The guidelines detail four basic steps involved with a job safety analysis: (1) Select the job to be analyzed, (2) separate the job into its basic steps, (3) identify the hazards associated with each step, and (4) control each hazard. By using this method, accidents can be

prevented by foreseeing and abolishing accidents before they happen.

Since many ergonomic hazards in mining result from manual materials handling, Gallagher (6) suggests that the materials supply-handling system be examined in addition to the jobs. A flowchart can be developed that represents the movement of supplies from the delivery at the mine to the supply item's end use. By closely examining the flowchart, unnecessary manual materials handling can be identified and eliminated, thus reducing the miners' exposure to lifting hazards. Figure 1 presents an example of flowcharts for handling concrete blocks at two different mines. There is much manual handling of the materials in mine A, while the blocks are handled mechanically until their end use in mine B.

Daling (3-4) has outlined safety analysis techniques that are useful for the mining industry, based upon certain criteria that the techniques must meet. The methods should not be too complex and should apply to most mining situations. Furthermore, the methods should be able to generate checklists and be cost effective. One of the hazard identification analyses identified as suitable for the mining industry that could be used to identify ergonomic hazards is the preliminary hazards analysis.

According to Hammer (9), the preliminary hazards analysis is broad in scope and performs the following functions: (1) identifies possible hazards, (2) looks for ways to eliminate the hazard, and (3) if the hazard cannot be eliminated, investigates the best way to control it. A

form is often developed where the hazard, contributing events, estimated probability, and means of control are listed. Hammer suggests a procedure of "signing off" on the form once the proper controls are taken so that these controls are sure to be carried out. Furthermore, Daling (4) warns of the dangers of the analyst simply filling out the form and caution that the analyst pay attention to subtle items and minute details.

The mine worker should not be overlooked as a valuable resource when identifying ergonomic stressors. Asking the miner to explain conditions that contribute to ergonomic hazards can often provide enlightening information, since the miner probably knows the job requirements and methods better than anyone. The miner may have already changed the workplace to lessen an existing problem that could result in an ergonomic stressor.

One effective means of getting information about possible ergonomic deficiencies from miners is with the critical incidence technique. This method collects data based on "hazards, near-misses, and unsafe conditions and practices from operationally experienced personnel" (9). The miner is asked about events that have happened to him or her or that he or she has seen first hand, similar to an accident investigation. If the critical incident technique is used to identify ergonomic problems, the work force must be informed about ergonomic principles. Once the ergonomic hazards have been identified, then solutions must be developed to eliminate or reduce the risk of these hazards.

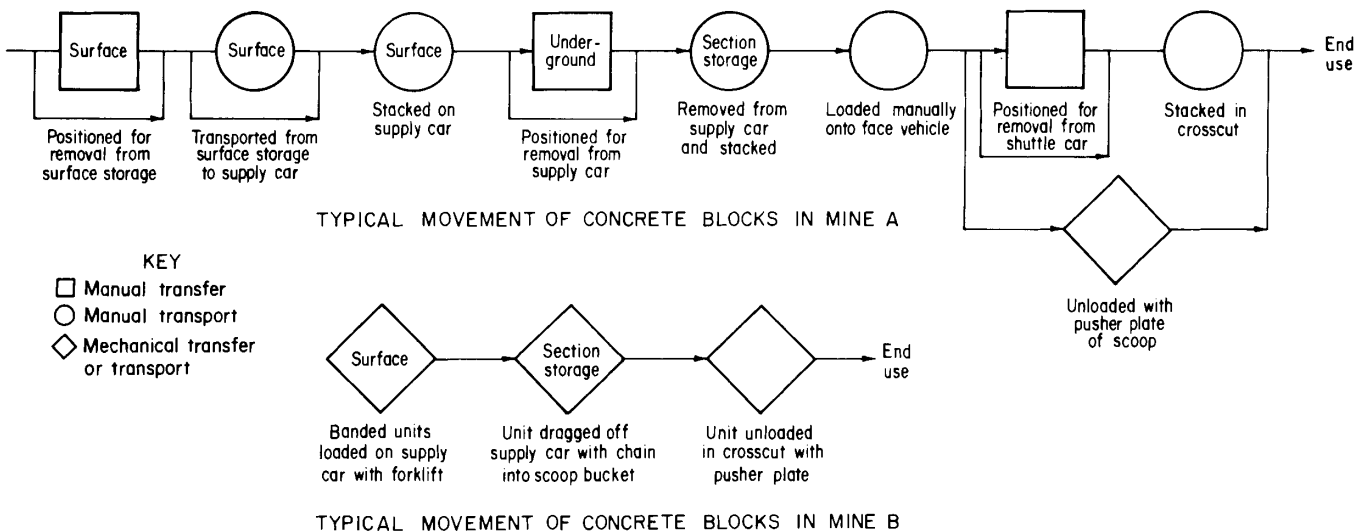

Figure 1.—Flowchart of concrete block transportation at two mines.

## DEVELOPING SOLUTIONS

Gallagher (6) presents a model for solving materials-handling problems (fig. 2); this model can be used to get rid of other ergonomic stressors as well. The ergonomic problem-solving strategies in the model include redesigning the job, using worker selection procedures, and training the work force in proper work methods.

The preferred solution to any ergonomic problem is to eliminate the hazard or remove the miner from any exposure. Proper planning can eliminate the need to perform a task at all. Gallagher (6, p. 25) provides an example in which an underground coal mine cut the number of manual lifts required to deliver a supply car of materials from 800 to 400 by keeping the supplies on the supply car during storage. This solution requires the purchase of an additional supply car, but can result in great savings by reducing the direct and indirect costs associated with occupational low-back pain.

If the hazard cannot be eliminated, the miner can be removed from any exposure to the hazard. For example, if a continuous miner operator is being exposed to dangerous levels of whole-body vibration while seated in a machine cab, the task could be redesigned so that the miner operates the machine from outside the cab using a remote control. The miner would then be removed from the vibration exposure.

The next strategy that should be considered to redesign the job, providing the previous strategies cannot be used, is to mechanize the task. One requirement for any piece of mechanized equipment is that it be rugged enough to withstand the harsh mining environment. Conway (2) has provided plans for six mechanical-assist devices that can be used to eliminate lifting associated with some underground mining tasks. These devices can be easily fabricated in most mine shops and include such items as a timber car, a scoop-mounted lift boom, and a container-work station vehicle. If the above strategies cannot be carried out, then the job must be designed so that it can be performed within the miners' capabilities. For example, it may not be possible to entirely eliminate a miner's exposure to whole-body vibration. However, the vibration levels should be lessened so that they are within existing standards. Furthermore, manual materials-handling tasks can be designed to fit the miners' capabilities.

The National Institute for Occupational Safety and Health (NIOSH) (11) provides guidelines for manual lifting that can prove useful for many situations in mining. Lifting capacity can be significantly lower, however, if the task is being performed in low coal, where the miner must work in constrained postures (7). One way that tasks can be designed to fit within a worker's capacity is to reduce the weight of the object being lifted. For example,

Gallagher (7) reports that rock dust packaged in 18-kg (40-lb) bags is a more appropriate size than 23-kg (50-lb) bags, given the reduced lifting capacity in restricted postures.

After any ergonomic solution is carried out, it is crucial that a followup analysis be performed. This followup is done to ensure that all ergonomic problems in the original job design are resolved and to guard against the introduction of any new ergonomic or safety hazards.

According to Snook (19), worker selection and training techniques alone are not an effective control for low-back injuries and the ergonomic redesign of jobs and workstations is the preferred approach. However, it is often "impractical, if not impossible, to design a job in such a manner that no training was required" (17). Thus, training should be an integral part of an effective ergonomics program. Furthermore, ergonomics training should be given to those workers who are serving on the ergonomics committee, as expressed earlier. Training should include an introduction to biomechanics (including safe lifting), anthropometry, and work physiology. In addition, ergonomic stressors common to mining, such as thermal stress, vibration, noise, and lighting, should be discussed. Annual refresher training could provide an excellent forum for such instruction.

Another strategy that supplements job redesign strategies to reduce occupationally related musculoskeletal injuries is the implementation of an exercise program. Exercise leads to improved strength and cardiovascular fitness that can, in turn, lead to a reduction in the costs associated with musculoskeletal injuries. However, one must be careful when implementing such a program: Gallagher (6, p. 28), advises that "the worker should consult with a physician prior to participation in any exercise program."

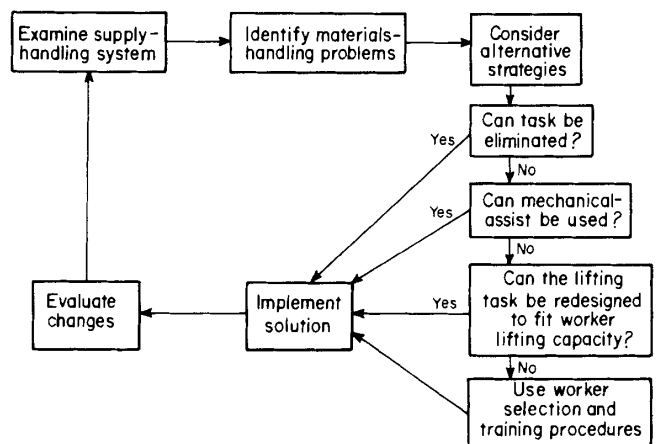

Figure 2.—Model for redesigning materials-handling tasks.

## CONTROL OF COSTS ONCE BACK INJURY HAS OCCURRED

The previous sections have detailed methods that can be useful in preventing low-back injuries. However, it is important for management to realize that some back injuries probably will occur, despite efforts to prevent them. When back injuries do occur, the policy that management puts in place to deal with the injury may have a significant role in determining the duration of the disability and the costs incurred by the company.

As discussed by Snook (18), management often does not respond properly when workers experience a back injury. The injured worker may be accused of malingering either by direct accusation or through innuendo. This, in turn, causes the workers to look for ways to get back at management. As such adversary situations develop, the costs of the injury may significantly increase for both the worker and management. However, as discussed by Snook (18), studies have indicated that enlightened management can often reduce and perhaps even prevent the disability associated with low-back pain through a program that includes positive acceptance of low-back pain, early intervention, good communication and followup, and early return-to-work programs.

### POSITIVE ACCEPTANCE OF LOW-BACK PAIN BY MANAGEMENT

The most appropriate response by a supervisor to a back injury experienced by one of his or her workers is to show concern for the needs of the employee, and to avoid making rash judgments and setting up adversary relationships because of the injury. Such judgments are usually incorrect and may serve to make the situation worse than it should be. Instead, management should be trained to realize that a certain number of back injuries are likely to occur and should be taught to respond in an appropriate manner when they do occur. The supervisor should encourage the worker to seek immediate medical treatment and (if possible) adapt the workplace or modify the task so that the employee can continue to work on the job. One company that instituted a policy of positive acceptance of low-back pain immediately and dramatically reduced its worker compensation costs. Over a 3-year period, costs were reduced from over \$200,000 per year to about \$20,000 per year (18).

### EARLY INTERVENTION

One key feature of the program described above was the fact that all workers complaining about low-back pain were immediately referred to the company clinic for

treatment—even those with minor complaints. Treatment was given during work time by the company nurse. This treatment consisted of heat applications and nonprescription analgesic-anti-inflammatory drugs, such as aspirin. During the treatment sessions, worker education was initiated on a one-to-one basis. The education program consisted of basic spinal anatomy and physiology, the expected results from the treatment regimen, proper posture, and suitable exercises. Light-duty work and rest periods were provided by management to the injured employee. If the initial in-house treatment was ineffective, the worker was referred to the company physician for further medical treatment. The physicians were familiarized with the physical demands of the jobs at the company to place injured workers in appropriate job positions.

Because this company encouraged the reporting of all episodes of low-back pain (even minor cases), it is not surprising that the number of cases reported actually increased. However, the amount of lost time due to low-back pain was significantly reduced. This indicates that the workers were able to stay on the job and did not rely on outside practitioners for treatment, thus reducing the company's cost because of low-back pain.

### FOLLOWUP AND COMMUNICATION

When workers do become temporarily disabled, it is important that management establishes and maintains good communications with the worker and appropriate medical personnel. Supervisors should be instructed to followup every disability case with a telephone call or visit before 2 days of lost time have elapsed. The purpose of the call is to let the worker know that the company is concerned and to inform the supervisor of the status of the worker's recovery.

One company recently instituted a program that increased the communication between the worker, employer, practitioner, and insurer (18). When a worker-compensation claim was received, the employer made immediate contact with the worker and insurer and followed up with calls at regular 10-day intervals to make certain that the claim was progressing smoothly. The possibility of retraining was explored for extended claims, and a liaison was established between management and the insurer if a gradual return to work was indicated. The focus of all communications was that every action taken was in the best interest of the worker. This program significantly reduced the proportion of long-term worker's compensation claims and also significantly reversed a trend of increasing accident rates (18).

## EARLY RETURN-TO-WORK PROGRAMS

The data from several studies have shown that the longer a worker is off from work because of a back injury, the less likely the worker will be able to return to productive employment. These studies underscore the importance of providing modified, alternative, or part-time work to the injured employee to facilitate a quick return to the job. Unfortunately, management will often extend the period of disability by requiring workers to be fully recovered before returning to work. This policy can often be more costly

than providing modified, alternative, or part-time employment to the injured employee. Because there appears to be a limited amount of time to act before losing control of the disability and the claim, efficient management should do everything in its power to encourage the worker's timely return to work. Data indicate that an early return to work is in the best interests of everyone: the worker, the company, and the union. In this regard, it may benefit both the company and the union to ensure that work rules in the current contract do not interfere with early return-to-work programs.

## SUMMARY

Occupationally related musculoskeletal injuries pose a significant problem to the mining industry, and ergonomics can help to reduce the costs associated with these injuries. Mines can start committees to solve ergonomic problems. These committees should include representatives from management, the labor force, and the medical department. Various analysis techniques, such as job safety analysis, task analyses, materials-handling flowcharts, and preliminary hazards analysis can be used to identify ergonomic problems in and around a mine.

Once hazards have been identified, then solutions can be formulated and realized. The preferred strategy is to redesign the job by getting rid of the hazard, removing the

worker from exposure, or mechanizing the task. If these strategies are infeasible, then the job should be designed so that it can be performed within the workers' capabilities. After any ergonomic solution is implemented, a followup analysis should be performed to ensure the effectiveness of the change and to guard against the introduction of any new ergonomic or safety hazards. Physical fitness programs and training can be used to supplement job redesign. By effectively instituting sound ergonomic implementation strategies, a healthier work force can be maintained and the costs associated with musculoskeletal disorders can be reduced, thereby reducing health care and compensation costs.

## REFERENCES

1. Andersson, G. B. Epidemiologic Aspects on Low-Back Pain in Industry. *Spine*, v. 6, No. 1, 1981, pp. 53-60.
2. Conway, E. J., and R. L. Unger. Material Handling Devices for Underground Mines (contract J0225005, Battelle, Pacific Northwest Lab.). BuMines IC 9212, 1989, 48 pp.
3. Daling, P. M., and C. A. Geffen. Evaluation of Safety Assessment Methods for the Mining Industry. Volume I. BuMines OFR 195(1)-83, 1983, 123 pp; NTIS PB 84-126440.
4. \_\_\_\_\_. Evaluation of Safety Assessment Methods for the Mining Industry. Volume II. User's Manual of Safety Assessment Methods for Mine Safety Officials (contract J0225005, Battelle, Northwest Lab.). BuMines OFR 195(2)-83, 1983, 96 pp; NTIS PB 84-126457.
5. Fettig, A. Selling Safety in the 90's. Growth Unlimited, Inc., Battle Creek, MI, 1990, p. 25.
6. Gallagher, S., T. G. Bobick, and R. L. Unger. Reducing Back Injuries in Low-Coal Mines: Redesign of Materials-Handling Tasks. BuMines IC 9235, 1990, 33 pp.
7. Gallagher, S., and C. A. Hamrick. Acceptable Workloads for Three Common Mining Materials. *Ergonomics*, v. 35, No. 9, 1992, pp. 1013-1031.
8. Goel, V. K., and J. N. Weinstein. Time-Dependent Biomechanical Response of the Spine. Ch. in *Biomechanics of the Spine: Clinical and Surgical Perspective*, ed. by V. K. Goel and J. N. Weinstein. CRC Press, Inc., Boca Raton, FL, 1990, p. 158.
9. Hammer, W. Occupational Safety Management and Engineering. Prentice-Hall, Inc., Englewood Cliffs, NJ, 4th ed., 1989, pp. 216-218, 552-554.
10. Imada, A. S. The Rationale and Tools of Participatory Ergonomics. Ch. in *Participatory Ergonomics*, ed. by K. Noro and A. Imada. Taylor and Francis, New York, 1991, pp. 30-49.
11. National Institute for Occupational Safety and Health. A Work Practices Guide for Manual Lifting, Tech. Rep. 81-122, U.S. Dep. Health and Hum. Serv. (NIOSH), Cincinnati, OH, 1981, 183 pp.
12. National Occupational Health and Safety Commission. National Standard for Manual Handling and National Code of Practice for Manual Handling, Mining Industry Supplement. Austral. Gov. Publ. Serv., Canberra, Australia, 1990, 13 pp.
13. O'Green, J. E., R. H. Peters, and A. B. Cecala. AEP Fuel Supply's Ergonomic Approach To Reducing Back Injuries. Paper in Proceedings, Twenty-Third Annual Institute on Mining Health, Safety, and Research. VA Polytech. Inst. and State Univ., Blacksburg, VA, 1992, pp. 187-195.
14. Plummer, R. W., T. J. Stobbe, and J. M. Peay. Cost Analysis of Back Injuries in Underground Coal Mining. *Annals of the American Conference of Governmental Industrial Hygienists*, Vol. 14, International Conference on the Health of Miners, ed. by R. W. Wheeler. ACGIH, Cincinnati, OH, 1986, pp. 469-474.
15. Pope, M. H. Modification of Work Organization. *Ergonomics*, v. 30, No. 2, 1987, pp. 449-455.
16. Pope, M. H., G. B. J. Andersson, J. W. Frymoyer, and D. B. Chaffin. Occupational Low Back Pain: Assessment, Treatment, and Prevention. Mosby-Year Book, Inc., St. Louis, MO, 1991, p. 215.
17. Sanders, M. S., and J. M. Peay. Human Factors in Mining. BuMines IC 9182, 1988, 153 pp.

18. Snook, S. H. The Control of Low Back Disability: The Role of Management. Ch. in *Manual Materials Handling: Understanding and Preventing Back Trauma*. Am. Ind. Hyg. Assoc., Akron, OH, 1989, pp. 97-101.

19. Snook, S. H., R. A. Campanelli, and J. W. Hart. A Study of Three Preventive Approaches to Low Back Injury. *J. Occup. Med.*, v. 20, No. 7, 1978, pp. 478-481.

20. U.S. Mine Safety and Health Administration (Dep. Labor). *The Job Safety Analysis Process: A Practical Approach, Participants Guide*. MSHA IG 83, 1990, 14 pp.

# DEVELOPING AND MAINTAINING SAFETY PROGRAMS FOR IMPROVED WORKER PERFORMANCE: DON'T FORGET THE BASICS

By Michael J. Klishis<sup>1</sup> and Ronald C. Althouse<sup>2</sup>

## ABSTRACT

While mines are safer today than they were in the past, miners are still being injured, maimed, and killed, and the incident and severity rates for the mining industry are still higher than those for most other industries. What's more, fatality rates are higher in the Nation's smaller mines and highest in the smallest mines. What can be done to improve safety in small mines?

One key to improved safety is worker performance. To be effective, companies need proactive safety interventions involving training, changes in policies or procedures, and/or modifications to equipment that address mine-specific needs and eliminate situations where the miner's actions unnecessarily expose him or her to hazards.

While outside resources such as governmental agencies, academic institutions, and equipment manufacturers can provide assistance to mine operators, it is up to individual mines and companies to develop effective safety programs.

This paper reviews the basics of developing safety interventions aimed at improving worker performance and describes approaches for maintaining program effectiveness. This information is based on research conducted at West Virginia University.<sup>3</sup> Emphasis is given to identifying performance discrepancies (hazardous behaviors) by observations (safety sampling), accident data analysis, and input from workers and supervisors.

## INTRODUCTION

Recent decades have seen safety regulations, improved mining techniques, safer mining equipment, and mandated safety training. Efforts by governmental agencies, equipment manufacturers, management, labor, and university researchers have resulted in these safer approaches, procedures, and equipment. While mines are safer today than they were in the past, miners are still being injured, maimed, and killed, and the incident and severity rates for the mining industry are still higher than those for most

other industries (1).<sup>4</sup> What's more, fatality rates are higher in the Nation's smaller mines and highest in the smallest mines (3).

Worker performance is the key to improved safety. Unfortunately, small mine operators with minimal resources and safety and training personnel often feel they lack the time, work force, and skills to develop and

<sup>1</sup>Assistant professor, Safety and Environmental Management.

<sup>2</sup>Professor and chair, Sociology and Anthropology.  
West Virginia University, Morgantown, WV.

<sup>3</sup>This research was funded by the U.S. Bureau of Mines under Cooperative Agreements C0167023 and C0178052, J. M. Peay, Technical Project Officer, Pittsburgh Research Center, Pittsburgh, PA.

<sup>4</sup>Italic numbers in parentheses refer to items in the list of references at the end of this paper.



implement effective safety programs. To be effective, companies need proactive safety interventions involving training, changes in policy or procedures, and/or modifications to equipment. These innovations and changes must address specific mine needs and eliminate situations where the miner's actions unnecessarily expose him or her to hazards.

While outside resources such as governmental agencies, academic institutions, and equipment manufacturers can provide assistance to operators, it is up to individual mines and companies to develop and maintain effective safety programs. The effectiveness of any program begins with the information that forms the basis of that program. The primary sources of information for a safety program are—

- Company records.
- Observation of employees.
- Ideas from workers and supervisors.

If safety interventions do not consider information from all of these sources, they may be based on faulty assumptions and fail to identify an organization's underlying safety problems or the most effective ways to eliminate those problems. Mine managers, safety officers, and trainers often do not get this information. This may be a result of inadequate planning, inappropriate information, lack of time, or outdated and inadequate methods of obtaining and maintaining data.

## DATA COLLECTION AND RECORDKEEPING

Obviously, company records should be the easiest data to obtain. Company records of value include reportable accident reports, nonreportable accident information, citations, and the mines' roof control plan. Information on equipment modifications or changes, and even maintenance and production data, also may indicate a safety problem.

To be useful, however, such records must be easy to obtain and in a format that is complete and detailed. Often, this is not the case. For example, while companies maintain records of reportable accidents, these records are often inadequate and may be functionally unusable. A cabinet full of accident forms is ineffective as a safety tool since it is difficult to analyze the data to determine problem areas and, if only reportable accident data are maintained, information about many other real or potential hazards may be missed.

Many managers, safety officers, and trainers now have access to easily maintained, computerized accident databases. These databases may be maintained on a personal computer (PC) or a company minicomputer or mainframe. A PC can be purchased at a very modest price, and there are many approaches to keeping accident, violation, maintenance, and production data. They may be off-the-shelf materials such as William's "FingerTips," or The Pennsylvania State University's (PSU's) "Management Incident Reporting System," or they may be developed specifically for your company. In addition, there are many commercial spread sheets and database programs that can be easily adapted for accident and violation recordkeeping.

If it is impossible to obtain the resources needed to establish and maintain a computerized database, some minimal data summarizing can be accomplished with the use of simple forms. The appendix includes several sample forms that might be useful for collecting and

summarizing accident data. Once accident information is summarized, it is possible to get an idea about the types of injuries that are occurring, the equipment or job classifications involved, sections or shifts that have a high number of accidents, etc.

However, simply maintaining accident information is not enough. Many accident reports do not include enough information about the circumstances surrounding the accident to permit managers and/or safety officers to make judgments about methods of preventing future occurrences of such accidents. Consider the following information taken from an actual report of a bolting-related accident:

### Example A:

|  |                        |
|--|------------------------|
| Job Title: <b>Roof Bolter Helper.</b>                              | Work at:               |
| Object: <b>Roof Bolter Galis</b>                                   | Body Parts: <b>Leg</b> |
| Description of Accident: <b>Bolting roof and strained his leg.</b> |                        |

This description, and others like "hit by rock while bolting," do not provide any clue to the actions of the miner at the time he or she was injured or if any subsequent training, equipment modifications, policy changes, or personnel actions might be appropriate.

The next description provides details about the action of the bolter operator at the time of the accident. This is the first step in gaining enough information to determine if some safety intervention is appropriate.

### Example B:

|   |   |
|---|---|
| Job Title: <b>Shuttle Car Opr.</b>  | Work at: <b>Operating bolting machine</b> |
| Object: <b>Roof Bolter</b>  | Body Parts: <b>Finger</b>                 |
| Description of Accident: <b>Preparing to push resin bolt into hole with machine; as he aligned bolt head &amp; bolt wrench, glove got caught on bolt, wrapped around bolt, pulled finger.</b> |   |

## SAFETY OBSERVATIONS OR BEHAVIOR SAMPLING

Observations of workers performing their normal work routine is a second key to the implementation of safety programs. Called behavior sampling or safety sampling, these observations permit a connection between the accident and the situation and hazards leading to the accident.

The performance discrepancies noted during observations may be quite different from those assumed from a mere analysis of accident data. For example, a large number of back injuries might lead one to believe that training workers on proper lifting procedures is in order. However, on-site observations may reveal that in order to complete certain tasks, miners must twist their bodies while in awkward postures or overextend their reach; therefore, lifting training would not reduce the hazards that led to these accidents.

Another example of the importance of observations concerns injuries from falling roof material. In roof bolting, the most frequently occurring accidents involve

injuries to the hands, arms, and shoulders caused by falls of roof material. Observations of bolters show that they often have their hands on the drill steel or drill pod-boom while drilling. This unnecessarily exposed them to falling roof material at a time when they are disturbing and fracturing the top, a situation that is likely to cause falling rocks and/or coal.

Observations can easily be made by managers, safety personnel, and/or supervisors, but there must be some systematic approach to conducting observations to ensure that the data are easy to collect and meaningful. If time permits, the observer could spend half a shift watching the bolting operators at work, but this is not necessary. A face boss could gather similar information by spending 5 min/d at some point when he or she was on the section. A Roof Bolting Observation Sheet (see figure 1) was developed to help when observations of bolter operators are conducted. This checklist allowed the observer to record behavior for the most common actions performed by bolter operators.

## CONDENSING AND ANALYZING DATA

Observations must be put in some condensed form to be useful. For example, the Roof Bolting Observation Sheet enabled the authors to make a simple tally of safe and exposed behaviors to determine where problems exist. Table 1 is a simple tally completed from observation sheets collected at a multiple section mine. It was easy to calculate the percentage of operator actions that resulted in hazard exposure (i.e., unsafe acts). It was also possible to determine the number of operators who consistently performed in a manner that left them exposed to hazards.

After collecting the observational data, they must be reviewed and analyzed in light of accident data to determine specific problems. The next task is to determine the best approach for correcting those problems. In many companies, the tendency is to institute a training program that will instruct the miners on how to work in a safer manner. Depending on the nature of the hazard exposure, this may or may not be the most effective approach.

Table 1.—Summary tally of bolter operator observations

| Bolting work task               | Number of observations | Unsafe acts | % unsafe | Problem bolters <sup>1</sup> |
|---------------------------------|------------------------|-------------|----------|------------------------------|
| Hands on rotating steel         | 160                    | 29          | 18       | 3                            |
| Hands on mast (drilling)        | 158                    | 94          | 59       | 7                            |
| Removing steels                 | 159                    | 31          | 19       | 4                            |
| Pinch points steels             | 77                     | 1           | 1        | 0                            |
| Align bolt wrench               | 75                     | 1           | 1        | 0                            |
| Hands on bolt wrench            | 76                     | 25          | 33       | 5                            |
| Hands on mast (inserting bolts) | 73                     | 36          | 49       | 6                            |

<sup>1</sup>Number of bolters observed = 12.

**ROOF BOLTING OBSERVATION SHEET**  
(Single Boom Bolter – 20-foot cut)

Observer: \_\_\_\_\_

Date: \_\_\_\_\_ Crew #: \_\_\_\_\_ Cut #: \_\_\_\_\_

**Drilling**

(w. starter)

Row 1 Row 2 Row 3 Row 4 Row 5  
**Hand on Rotating Steel**

|         |                          |                          |                          |                          |                          |
|---------|--------------------------|--------------------------|--------------------------|--------------------------|--------------------------|
| Safe    | <input type="checkbox"/> | <input type="checkbox"/> | <input type="checkbox"/> | <input type="checkbox"/> | <input type="checkbox"/> |
| Exposed | <input type="checkbox"/> | <input type="checkbox"/> | <input type="checkbox"/> | <input type="checkbox"/> | <input type="checkbox"/> |

**Hand on Mast/Drill Head**

|         |                          |                          |                          |                          |                          |
|---------|--------------------------|--------------------------|--------------------------|--------------------------|--------------------------|
| Safe    | <input type="checkbox"/> | <input type="checkbox"/> | <input type="checkbox"/> | <input type="checkbox"/> | <input type="checkbox"/> |
| Exposed | <input type="checkbox"/> | <input type="checkbox"/> | <input type="checkbox"/> | <input type="checkbox"/> | <input type="checkbox"/> |

**Removing Steel from Hole**

|         |                          |                          |                          |                          |                          |
|---------|--------------------------|--------------------------|--------------------------|--------------------------|--------------------------|
| Safe    | <input type="checkbox"/> | <input type="checkbox"/> | <input type="checkbox"/> | <input type="checkbox"/> | <input type="checkbox"/> |
| Exposed | <input type="checkbox"/> | <input type="checkbox"/> | <input type="checkbox"/> | <input type="checkbox"/> | <input type="checkbox"/> |

**Drilling**

(w. finisher)

**Avoid Pinch Points**

|         |                          |                          |                          |                          |                          |
|---------|--------------------------|--------------------------|--------------------------|--------------------------|--------------------------|
| Safe    | <input type="checkbox"/> | <input type="checkbox"/> | <input type="checkbox"/> | <input type="checkbox"/> | <input type="checkbox"/> |
| Exposed | <input type="checkbox"/> | <input type="checkbox"/> | <input type="checkbox"/> | <input type="checkbox"/> | <input type="checkbox"/> |

**Hand on Rotating Steel**

|         |                          |                          |                          |                          |                          |
|---------|--------------------------|--------------------------|--------------------------|--------------------------|--------------------------|
| Safe    | <input type="checkbox"/> | <input type="checkbox"/> | <input type="checkbox"/> | <input type="checkbox"/> | <input type="checkbox"/> |
| Exposed | <input type="checkbox"/> | <input type="checkbox"/> | <input type="checkbox"/> | <input type="checkbox"/> | <input type="checkbox"/> |

**Hand on Mast/ Drill Head**

|         |                          |                          |                          |                          |                          |
|---------|--------------------------|--------------------------|--------------------------|--------------------------|--------------------------|
| Safe    | <input type="checkbox"/> | <input type="checkbox"/> | <input type="checkbox"/> | <input type="checkbox"/> | <input type="checkbox"/> |
| Exposed | <input type="checkbox"/> | <input type="checkbox"/> | <input type="checkbox"/> | <input type="checkbox"/> | <input type="checkbox"/> |

**Removing Steel(s) from Hole**

|         |                          |                          |                          |                          |                          |
|---------|--------------------------|--------------------------|--------------------------|--------------------------|--------------------------|
| Safe    | <input type="checkbox"/> | <input type="checkbox"/> | <input type="checkbox"/> | <input type="checkbox"/> | <input type="checkbox"/> |
| Exposed | <input type="checkbox"/> | <input type="checkbox"/> | <input type="checkbox"/> | <input type="checkbox"/> | <input type="checkbox"/> |

**Bolting**

**Aligning Bolt & Wrench**

|         |                          |                          |                          |                          |                          |
|---------|--------------------------|--------------------------|--------------------------|--------------------------|--------------------------|
| Safe    | <input type="checkbox"/> | <input type="checkbox"/> | <input type="checkbox"/> | <input type="checkbox"/> | <input type="checkbox"/> |
| Exposed | <input type="checkbox"/> | <input type="checkbox"/> | <input type="checkbox"/> | <input type="checkbox"/> | <input type="checkbox"/> |

**Hand on Bolt while Inserting (raising/spinning)**

|         |                          |                          |                          |                          |                          |
|---------|--------------------------|--------------------------|--------------------------|--------------------------|--------------------------|
| Safe    | <input type="checkbox"/> | <input type="checkbox"/> | <input type="checkbox"/> | <input type="checkbox"/> | <input type="checkbox"/> |
| Exposed | <input type="checkbox"/> | <input type="checkbox"/> | <input type="checkbox"/> | <input type="checkbox"/> | <input type="checkbox"/> |

**Hand on Mast while Inserting Bolt**

|         |                          |                          |                          |                          |                          |
|---------|--------------------------|--------------------------|--------------------------|--------------------------|--------------------------|
| Safe    | <input type="checkbox"/> | <input type="checkbox"/> | <input type="checkbox"/> | <input type="checkbox"/> | <input type="checkbox"/> |
| Exposed | <input type="checkbox"/> | <input type="checkbox"/> | <input type="checkbox"/> | <input type="checkbox"/> | <input type="checkbox"/> |

**Bolt Spin Times (fully grouted bolts only) Manufacturer's recommended time:**

|                 |                          |                          |                          |                          |                          |
|-----------------|--------------------------|--------------------------|--------------------------|--------------------------|--------------------------|
| Time in seconds | <input type="checkbox"/> | <input type="checkbox"/> | <input type="checkbox"/> | <input type="checkbox"/> | <input type="checkbox"/> |
|-----------------|--------------------------|--------------------------|--------------------------|--------------------------|--------------------------|

**Bolt torqued**

Torque range:

|     |                          |                          |                          |                          |                          |
|-----|--------------------------|--------------------------|--------------------------|--------------------------|--------------------------|
| Yes | <input type="checkbox"/> | <input type="checkbox"/> | <input type="checkbox"/> | <input type="checkbox"/> | <input type="checkbox"/> |
|-----|--------------------------|--------------------------|--------------------------|--------------------------|--------------------------|

**Other Observations:** circle observations (use the back of this sheet for additional comments)

|  |   |   |   |
|--|---|---|---|
| <p><b>Bolts Bent</b> not seen</p> <p>a) Jams bolt into ground (like bow)</p> <p>b) Bends over tire</p> <p>c) Bends elsewhere on bolter</p> | <p><b>Dust Box Emptied</b> not done</p> <p>a) After bolting place</p> <p>b) When filled</p> <p>c) Due to no suction</p> | <p><b>Canopy</b> no canopy</p> <p>a) Inadequate size</p> <p>b) Bolter doesn't stay under</p>                        | <p>Bolt pattern followed y / n</p> <p>Personal protection worn y / n</p> <p>Scaling done properly y / n</p> |
| <p><b>Laying Bolts Out</b> not done</p> <p>a) On ground</p> <p>b) On bolter</p> <p>c) Against rib</p>                                      | <p><b>Methane Checks</b> not done</p> <p>a) Done incorrectly (no extension rod, etc)</p> <p>b) Done correctly</p>       | <p><b>ATRS</b></p> <p>a) Not properly positioned</p> <p>b) Not pressurized to roof</p> <p>c) Stab jacks not set</p> | <p>Supplying done properly y / n</p> <p>Test Hole (if needed) y / n</p> <p>Tramming properly y / n</p>      |

Figure 1.—Roof Bolting Observation Sheet.

## ANALYZING PERFORMANCE PROBLEMS AND THE DECISION-MAKING FLOWCHART

Performance problems, whether related to safety or productivity, arise from many different sources and, in turn, have differing solutions. A *human performance discrepancy* (i.e., a worker action or behavior that isn't performed in a desired manner) must be examined in light of potential solutions. All too often, managers decide that the only ways to correct a performance discrepancy is to train or terminate workers when neither of these is the most appropriate action.

In the book *"Analyzing Performance Problems or 'You Really Oughta Wanna'"* (2), a procedure is discussed for analyzing performance problems and selecting appropriate solutions. Possible actions are suggested, such as formal training, practice, feedback, removing obstacles, arranging consequences, changing the job, and transferring or terminating personnel. To assist the manager, trainer, or safety officer in determining which solution is best, they developed a decisionmaking flowchart. This flowchart was expanded by Klishis<sup>5</sup> and modified to reflect the "three E's" of safety: engineering, education, and enforcement. The modified version of the flowchart is shown in figure 2. This version describes possible solutions under four basic categories: education (training), engineering (ergonomics), enforcement (policies-procedures), and personnel actions.

To use the flowchart, you begin by identifying the problem, labeled on the chart as a *"performance discrepancy."* Once a performance discrepancy is identified, decide if the problem is important. Just because a worker doesn't perform in the appropriate manner does not mean that it is really a problem. Often, workers will develop their own patterns and routines for performing a task. These "idiosyncratic behaviors" may be as good as, if not better than, those in the operating or training manuals. If the behavior of the worker is safe, efficient, and productive, it is probably not a problem and should be ignored. To use a sports analogy, if a batter has the wrong batting stance, doesn't keep his eye on the ball, "puts his foot in the bucket," etc., but manages to bat .300 with power and doesn't strike out, does his form really matter? Getting the job done is the important thing.

However, if the worker's performance is unsafe or results in inefficiencies that hurt production, then this is a performance problem that should be corrected. The next step is to determine the cause of the discrepancy. Determine if the problem is a skill deficiency. That is, is the

worker's failure to perform the task correctly because he or she doesn't know how to do the job? If the worker has just been assigned to a new job, or must use a piece of equipment that operates in a manner very differently from the old equipment, training is the best solution.

On the other hand, perhaps the skill deficiency is a result of disuse of the skill. For instance, a miner who used to be a bolting machine operator months or years ago, but has been working as a continuous miner operator or as a shuttle car operator, is reassigned as a roof bolter. The worker's skills are "rusty" and he or she doesn't perform in the manner expected. In this case, it is practice, not training that is needed to get him or her "up to snuff."

Sometimes a worker may be performing in an unacceptable manner and not realize it. No one has told the worker that he or she is performing in an unsafe or unproductive manner. The worker is doing what he or she thinks is right and will continue to do so until someone gives him or her appropriate feedback about his or her performance. Many of our skills or approaches will change over time, and perhaps we pick up an unfortunate habit or maneuver that isn't safe, even though it gets the job done and seems okay to us. If we aren't told we are performing a task incorrectly, we can't be expected to correct our errors.

Perhaps the problem is not a skill deficiency; perhaps the task, as it is planned or designed, is not appropriate. That is, no matter how carefully the worker performs the task, there is unnecessary exposure to a hazard or inefficient production. Then the solution is an engineering one.

Perhaps the problem is not a skill deficiency; perhaps there are obstacles that prevent the task from being performed correctly. If a bolter operator doesn't have a torque wrench, or the methanometer is inoperative or missing the extension rod, the operator cannot perform the work safely. If there have been requests for a new torque wrench or methanometer, and none is forthcoming, it is not the operator's fault. In this situation, it is up to the manager, supervisor, or safety officer to ensure that the obstacle to performing a task correctly (lack of appropriate or functioning equipment) is removed (the miner is given needed equipment).

At other times, the problem may be a case of "inappropriate consequences." Consider the situation where the worker's performance on a specific task may not matter, thus the task doesn't get performed. For example, if it is part of the bolter operators' job to rock dust the workplace after bolting it, but the supervisor ignores this task unless an inspector is around, or has general inside laborers dust it on the next shift, why would the bolter operators perform the task? It doesn't matter to them if they do it or not. In this case, it is up to the supervisor to

---

<sup>5</sup>OFR 113g-93. Coal Mine Injury Analysis: A Model for Reduction Through Training. Vol. III—Accident Risk During the Roof Bolting Cycle: Analysis of Problems and Potential Solutions, by M. J. Klishis, R. C. Althouse, T. J. Stobbe, R. W. Plummer, R. L. Grayson, L. A. Payne, and G. M. Lies.

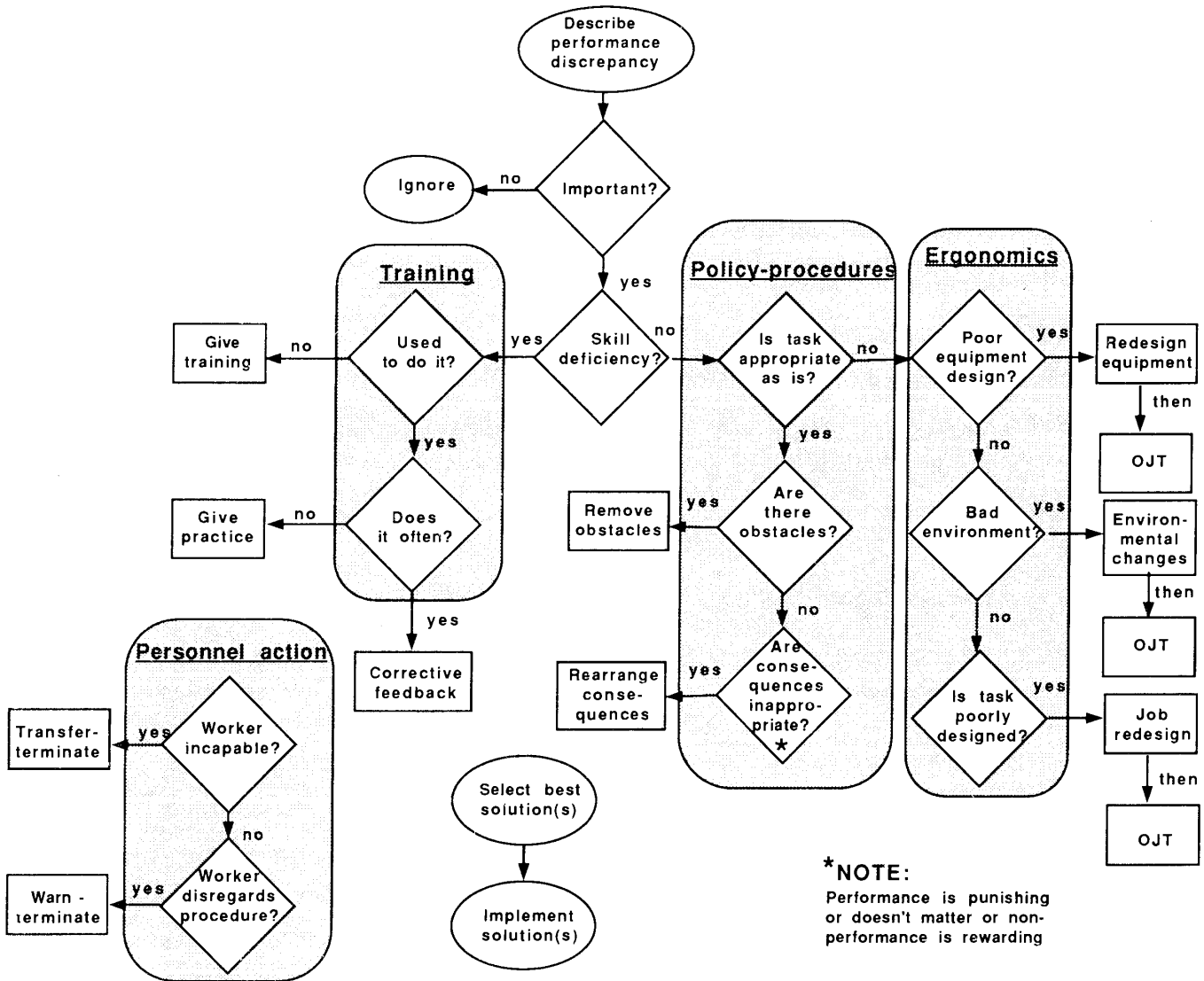

Figure 2.—Decisionmaking flowchart. [Adapted from Mager and Pipe (2)]

"consequence" the behavior, perhaps by "getting on" the bolters if they fail to rock dust.

There are other types of inappropriate consequences. The most common situation involves a task that is "punishing" to perform correctly. Bolting a potted-out place where the automatic temporary roof support (ATRS) won't reach is a good example of this situation. If the ATRS won't reach, the roof still has to be bolted. The proper procedure in this situation would be to set jacks, build a ramp, add a crib block to the top of the ATRS, or use the ATRS extenders to gain the height necessary to get the ATRS to support the roof. Unfortunately, each of these choices requires considerable work, and most bolter operators admit that rather than go to all of this effort, including slowing down work on the production section, they will simply ignore the problem and bolt while under

unsupported top. In this case, only a strongly enforced company policy that demands that the task be performed safely will counteract the aversive effects of performing it correctly.

In other cases, the task may not be appropriate. That is, no matter how the worker tries, the task can't be performed safely. In these situations, the problem is an ergonomic one and the solution is an engineering one. To get the desired performance, the equipment will have to be redesigned, the environment changed, or the job redesigned before the worker can perform safely. For example, if the bolter operator can't stay under the drill canopy because it is too small, the canopy will have to be enlarged. If the bolter operator usually cannot reach the top to insert the glue and bolt and has to climb on top of the drill pod to get the necessary height, the bolting machine is obviously

too small for the seam and only a more appropriate model will really solve the problem. However, an interim step may be to add a "step-up" device to the machine to permit the bolter operator to climb up on the drill pod in a safer manner.

Another example might be an environmental problem. If an operation is plagued with bad ribs and bolter operators are getting injured by rib rolls, then rib bolting may be one solution, purchasing a walk-through bolting machine another, or perhaps both solutions are needed.

The final alternative is a personnel action. If, after addressing the situation with the recommendations suggested above, the worker is still incapable of performing the task correctly, he or she should be transferred to a different job where it is possible to perform in an

appropriate manner. If the employee is capable of performing the task, but simply not willing to perform it correctly, a transfer may also be in order. In either case, if the employee won't perform or is incapable of performing tasks correctly, termination should be considered, but only as a last option. Terminations are always a hassle, but may need to be considered if the safety of the employee and other workers is at stake.

After going through the flowchart and looking at the various possibilities, there may be more than one solution to the problem. At this point, the best solution is selected and implemented. The best solution is determined by the nature of the problem, the time and resources available to correct the problem, and legal or contractual responsibilities.

## COMMUNICATION AND EMPLOYEE FEEDBACK

Good interactive communication and employee feedback are also essential in identifying, designing, and implementing any type of safety innovation. The workers are an important resource and their knowledge can be critical in identifying potential problem areas that have an impact on safety and efficiency. Today we hear much about total quality management and quality circles. These techniques are effective because they rely on employees for input and direction. Workers have many ideas on how to improve safety and productivity. Often an individual employee will have developed a "gizmo" or procedure to make work easier, faster, and/or safer; unfortunately, these ideas usually don't go beyond the worker or a crew in the mine.

Involving the workers themselves in the process will allow you access to these ideas, techniques, and modifications. Of course it is best to review these suggestions with experts who are knowledgeable about the process or equipment such as Federal or State agents, equipment manufacturers, representatives from educational institutions, or the U.S. Bureau of Mines (USBM) from the standpoint of safety and efficiency, but usually these suggestions are very valuable and can be easily implemented.

Another benefit gained by involving the miners themselves is that they are usually more receptive to changes in their jobs or work routines when they are involved in planning and/or designing those changes. The changes then become "their" changes rather than changes mandated by management.

When a change is implemented, it is also important to be sure that the "message" gets through to the employees. Effective communication requires reaching all the

employees and informing them not only of the change, but the reason for that change. If not, they may not understand why a change was made and may ignore or even subvert the intervention. For example, one operation decided to weld a small piece of pipe to the bolting machine. This pipe was supposed to serve as an "aid" when bending bolts. The change was agreed upon at a meeting that included the safety director and the union safety committee chairperson. Unfortunately, all of the bolter operators were not informed of the reason for this "modification." As a result, one operator had the pipe removed. Another operator determined that the pipe was mounted at the wrong angle, but instead of having the angle corrected, he or she also had the pipe cut off. As a result of the failure of management to communicate with the work force and of a worker to communicate with management, the well-designed intervention was a failure.

Improved communication also means the transfer of ideas between sections of the same mine and/or other mines in the same company. In working with "umbrella" companies with several small mines, researchers have observed safety improvements installed in one mine but not in other mines of the same company. They have even observed improvements in one section of a mine but not in another.

Communication also means keeping employees informed about what is happening in the mine. What kind of information does the face boss and/or the workers get when they start a shift? Are they told about safety-related problems or bad conditions? Have any changes or innovations designed as a safety intervention be initiated? If so, what are they and why were they made?

## PROBLEMS FACED WHEN BUILDING AND MAINTAINING A SAFETY PROGRAM

Small operations, even "umbrella" operations that service several single unit mines, usually do not have enough data on accidents to make well-informed choices on safety and training interventions. Fortunately, accidents are a rare occurrence in any operation, but this results in a database that consists of a few, highly scattered incidences. It is difficult, if not impossible, to draw conclusions from such limited information.

To have enough information to make decisions, small operations need a database and hazard inventory built on a large accident pool. An example of one such database is the roof bolting accident database developed by researchers at West Virginia University's (WVU's) Mining Extension Service.<sup>6</sup> This database and the resulting hazards inventory served as a guideline for making observations and taking actions to improve bolting safety at several small operations.

Another problem safety personnel at smaller operations face is the need to make safety sampling observations with

limited time and resources. Ideally, observations should be made by face bosses, but problems abound. There never seems to be any time to train face bosses to make observations, and if they are trained, they have so many demands on their time that they don't feel that they have time to make observations.

Supervisors required to make observations face another dilemma. They don't want to look bad or have their section or people look bad, so they are hesitant of making "accurate" (truthful) observation reports for fear of actions against them and/or job loss.

Although supervisors are the best persons to make safety observations, we cannot forget the safety manager. It is important that safety officers go underground, learn what is really happening in the mine, and identify potential problem areas.

## TRAINING AS A SAFETY INNOVATION

Another problem faced by operators of small mines is making effective use of mandated health and safety training. Too often, training is done for compliance, not for safety. Training done by well-meaning, knowledgeable entrepreneurs who have little knowledge of the operation's specific safety problems serve to comply with the law but do little to meet the "true" safety training needs of the operation. When these entrepreneurs are finished training, the operator has a 5000-23 form with the correct boxes checked, but the safety level of the operation is at best maintained at an ongoing level, not improved. If training is to be an effective approach to improving safety, the trainer must treat training as an opportunity for improvement, not just as an activity needed to comply with governmental regulations.

To be effective, training must be tailored to identified, specific company or mine needs. Canned or generic programs may include good information and many valid points, but do they really meet the needs of your organization? Training should also go beyond mandated

requirements. If a problem exists with a certain piece of equipment or job classification, take the time to give appropriate training on that area. It is easy to cut training to the bare minimum, but in the long run this is not cost effective.

Finally, management must not view safety as a "one-shot" deal. Once there has been a successful implementation of a safety intervention, the job is not over. Management must consider safety as a continuous process that requires constant attention and effective communications to maintain quality and safety on all working sections. Effective training involves the entire organization in an attempt to keep the workers safe and productive.

Management must demonstrate its support for the training effort. This means taking interest in the training program, meeting with workers during annual refresher training sessions, and encouraging them to work in a safe manner. It means demanding that supervisors work in a safe manner and that they ensure that work crews and individual miners are also working safely.

## OTHER INITIATIVES

While mine operators have the primary responsibility for maintaining a safe workplace, it is difficult for them to "go it alone." Safety and training assistance for small

operators is needed from Federal and State agencies, technical schools, junior colleges, and major mining institutions with "outreach" services (WVU, PSU, etc.). In 1980, a report by John Short & Associates (4) suggested that the most effective approach to work force

<sup>6</sup>Work cited in footnote 5.

development and training in the mining industry would be a national mining extension service. Perhaps it is time to reexamine that idea and strengthen the service to small operators. In this light, WVU's Mining Extension Service has recently stepped up and expanded its service to small mine operators in West Virginia.

The USBM has long been involved in research that has been a tremendous assistance to the mining industry. To be most effective, the USBM should continue to place an increased emphasis on human factors and training for small mine operators while maintaining its traditional research orientation for equipment and mining techniques.

The interchange of information is one key to successful safety and training programs. All governmental agencies should encourage and support local, regional, and national meetings of safety and training personnel, such as the Holmes Safety Association, State grants meetings, training resources applied to mining, and the National Mine Instructors Conference.

Of course the U.S. Mine Safety and Health Administration (MSHA) has an important function and can be a key agency in the improvement of safety in small mines. It should continue its efforts to develop easy access of Safety and Health Technical Center (SHTC) data for all operators (such as data on diskettes and user-friendly programs), but it can also provide much needed data to the small operator and academic researchers by conducting finer grained, more useful analyses of accidents in the SHTC database. These analyses should be similar to the "microanalysis" conducted at WVU.<sup>7</sup>

What does this have to do with small mine operators? Simply put, while government agencies and educational institutions strive to provide the assistance and services needed most by the mining industry, small mine operators need to make their needs and wishes known to these agencies and encourage the support and funding of programs that are beneficial and practical.

## CONCLUSIONS

The safety program basics suggested here involve identifying situations and conditions under which miners are injured and using that information to develop interventions for critical areas in the job task. The key steps in this process are the analysis of accident and injury data, observations of employees performing tasks, communications between workers and supervisors, and development of appropriate training.

Although governmental agencies can provide assistance to operators in the form of research, especially in the area of human factors, and assistance in the interchange of ideas, it is up to the operator to place the appropriate emphasis on safety and training at his or her operation. This means management's involvement in the effort and viewing safety and training as an ongoing, ever-changing, integrated process.

## REFERENCES

1. Jenkins, E. L., S. M. Kisner, and D. E. Fosbroke. Fatal Injuries to Workers in the United States, 1980-1989: A Decade of Surveillance: National Profile. GPO, DHHS Publ. NIOSH 93-108, 1993, 337 pp.
2. Mager, R. F., and P. Pipe. Analyzing Performance Problems or 'You Really Oughta Wanna.' Lake Publ. Co., Belmont, CA, 1984, 143 pp.
3. Peters, R. H., and B. Fotta. Statistical Profile of Accidents at Small Underground Coal Mines. Paper in this proceedings.
4. Siedenstrang, D., D. Ellingwood, and J. Short. Manpower and Training Model for the Mining Industry (contract J0357109, John Short & Assoc., Inc.). BuMines OFR 92-81, 1980, 219 pp.; NTIS PB 81-222325.

---

<sup>7</sup>Work cited in footnote 5.



## APPENDIX.—ACCIDENT DATA COLLECTION AND SUMMARY FORMS

When building a safety program that will permit the development and implementation of safety interventions, one resource is company data such as accident and injury information. Other company records of value include citations of the roof control plan, information on equipment modifications or changes, and even maintenance and production data. To be useful, however, such records must be easily obtainable and in a format that is complete and appropriately detailed, which means establishing a comprehensive and useful database.

The focus of any safety program begins with accident and injury data. Unfortunately, these accident records are often inadequate or unusable. While accident information is required by regulatory agencies (MSHA and State mining departments) and for insurance purposes (Worker's Compensation), it is often maintained as a number of reports in a filing cabinet. These reports may not be an effective safety tool since (1) they are designed to meet the needs of outside agencies, not company safety and training personnel, and (2) it is difficult to analyze data that are in raw report form.

The first step in establishing an effective database begins with the collection of accident data that are useful to a safety program. While the information required by government agencies may be of some use, there are many "nonreportable" accidents that should be considered. In addition, the most important information in an accident report is the description of the situation or circumstances that surround the accident: What was the worker doing just before and when he or she got injured; how did he or she get into the situation; if there was any warning before the incident occurred, how did the worker react; and what can be done to prevent such an incident in the future?

To get this information you need an accident form that specifies the reporting of incidents in enough detail and a company policy requiring the reporting of all incidents where a worker is injured. This requires getting a report from the victim and/or the victim's supervisor, as well as

a followup visit, especially in the case of nonfatal days lost (NFDL's), to discuss the accident with the victim, the supervisor, and any witnesses. The two-page mine accident form with its accompanying supplemental third page for evaluation by a safety officer is an example of such a method of collecting accident information (see figure A-1). You may find it useful for your operation.

The key to this form is the narrative description of the accident (second page) and the accident assessment (third page). Getting detailed information on the incident rather than simplistic descriptions such as "hit by rock" will give you an idea of the kind of problems that may exist and a starting point for observations.

The second step in maintaining accident data is consolidation into a useful summary that permits safety officials and mine management to maintain a "handle" on accidents. Such a form may be similar to the mine's production reports. There are two forms in this package that may be useful. The first, called the Accident Summary Sheet (fig. A-2), is designed to keep a running tally of accidents. The second, called the Lost Time Accident Summary Sheet (fig. A-3), serves as a simple way to summarize accidents on a monthly and yearly basis.

Once the mine's accident data has been summarized, the mine operator can look for trends or problem areas. Remember, it is necessary to couple the analysis of accident data with a review of the narrative descriptions of the accidents and on-site observations to be able to pinpoint both the problem and its cause, as well as to identify potential corrective actions.

Don't forget the other company data. Citations for safety violations from Federal and State inspectors or writeups from company compliance officers can help to pinpoint problem areas. As with accident information, there has to be some organization of the information. A simple listing made on a form such as the Violation Summary Sheet (fig. A-4) might be helpful in identifying repeated violations that can be a sign of a problem.

### Mine Accident Form

Name: \_\_\_\_\_ Date of Accident: \_\_\_\_\_

Witness: \_\_\_\_\_ Time of Accident: \_\_\_\_\_

Mine: \_\_\_\_\_ Date Reported: \_\_\_\_\_

Age: \_\_\_\_\_ Sex: M / F

**Days Lost From Work:** Was there time lost from work (or) time lost and restricted work? Y / N

Total lost days from work (if any) \_\_\_\_\_

### Occupational Information

Regular Job Title: \_\_\_\_\_

Job/Activity When Injured: \_\_\_\_\_

Total Years Mining Experience: \_\_\_\_\_ Years at Present Mine: \_\_\_\_\_

Years at Present Job title: \_\_\_\_\_

### Accident Information

Location of Accident in the Mine: (Circle all appropriate choices)

Underground / Surface

- 1. Face
- 2. Intersection
- 3. Haulageway
- 4. Mantrip / transportation
- 5. Underground shop or office
- 6. Belt area
- 7. Other \_\_\_\_\_

Source of Injury: \_\_\_\_\_

What Object/Material caused the injury, i.e., drill steel, falling roof, electrical cable, crib...etc.)

Body Parts Injured and Type of Injury (list as many as applicable):

| <u>Body Part Injured</u> | <u>Type of Injury (cut, fracture, etc.)</u> |
|--------------------------|---|
| _____                    | _____                                       |
| _____                    | _____                                       |
| _____                    | _____                                       |

Figure A-1.—Mine Accident Form.

## **Description of Accident**

### **Instructions:**

Please give a detailed description of the accident. The purpose of this form is to help in the development of safety and training materials to make it safer to work in this mine. The more information you give the more useful it will be to you and your fellow workers.

Thank you.

**Accident Form Supplement**  
(To be completed by safety officer)

Name: \_\_\_\_\_ Date of Accident: \_\_\_\_\_

Mine: \_\_\_\_\_ Date Reported: \_\_\_\_\_

Is there safety/training material that is related to this accident on hand? Y/N

If YES, is the material current? Y/N

Has the injured received safety/training material related to this accident in the last year? Y/N

Personal observations from accident site:

Comments from supervisor/witnesses:

Provide an assessment of the accident including what actions can be taken to prevent the recurrence of this type of accident:



**LOST TIME ACCIDENT SUMMARY SHEET**

|                     |     |   |                      |     |                      |     |
|---------------------|-----|---|----------------------|-----|----------------------|-----|
| Operations With LTA |     | <b>TOTAL INJURIES</b><br><br>HEAD _____<br>EYE _____<br>NECK _____<br>SHOULDER _____<br>ARM _____<br>HAND _____<br>FINGERS _____<br>CHEST _____<br>BACK _____<br>ABDOMEN _____<br>LEG _____<br>FOOT _____<br>TOES _____<br><br>THE<br>RIGHT WAY<br>IS THE<br>SAFE WAY | Occupations With LTA |     | Occupations With LTA |     |
| Operation           | No. |   | Occupation           | No. | Occupation           | No. |
|                     |     |   |                      |     |                      |     |
|                     |     |   |                      |     |                      |     |
|                     |     |   |                      |     |                      |     |
|                     |     |   |                      |     |                      |     |
|                     |     |   |                      |     |                      |     |
|                     |     |   |                      |     |                      |     |
|                     |     |   |                      |     |                      |     |
|                     |     |   |                      |     |                      |     |
|                     |     |   |                      |     |                      |     |
|                     |     |   |                      |     |                      |     |
| TOTAL               |     |   | TOTAL                |     | TOTAL                |     |

|           |     |             |     |  |  |   |  |  |
|-----------|-----|-------------|-----|--|--|---|--|--|
| SHIFT     | NO. | LOCATION    | NO. | <b>AGE</b><br><br>YEARS   NO.<br>To 20        <br>21 - 25        <br>26 - 30        <br>31 - 35        <br>36 - 40        <br>41 - 45        <br>46 - 50        <br>51 - 55        <br>56 - 60        <br>OVER 60        <br>TOTAL   |  | <b>EXPERIENCE</b><br><br>CURRENT JOB   TOTAL MINING<br>0 - 1 mo        <br>2 - 12 mo        <br>1 - 2 yrs        <br>2 - 3 yrs        <br>3 - 4 yrs        <br>4 - 5 yrs        <br>3 - 4 yrs        <br>5 - 10 yrs        <br>10 - 15 yrs        <br>15 - 20 yrs        <br>over 20 yrs        <br>TOTAL |  |  |
| DAY       |     | SECTION     |     |  |  |   |  |  |
| AFTERNOON |     | NON-SECTION |     |  |  |   |  |  |
| MIDNIGHT  |     | SURFACE     |     |  |  |   |  |  |
| TOTAL     |     | TOTAL       |     | <b>ACCIDENT CATEGORY</b>   NO.   <b>NATURE/INJURY</b>   NO.  <br>MAT'L HAND         STRAIN        <br>SLIP/FALL         SPRAIN        <br>HAULAGE         FRACTURE        <br>MACHINERY         LACERATION        <br>ROOF FALL         CONTUSION        <br>RIB FALL         AMPUTATION        <br>ELECTRICAL         ELECT. SHOCK        <br>HAND TOOLS         BURN        <br>OTHER         OTHER        <br>TOTAL         TOTAL |  |   |  |  |
|           |     |             |     |  |  |   |  |  |
|           |     |             |     |  |  |   |  |  |
|           |     |             |     |  |  |   |  |  |
|           |     |             |     |  |  |   |  |  |
|           |     |             |     |  |  |   |  |  |
|           |     |             |     |  |  |   |  |  |
|           |     |             |     |  |  |   |  |  |
|           |     |             |     |  |  |   |  |  |
|           |     |             |     |  |  |   |  |  |

|                      |       |     |     |     |     |     |     |     |     |     |     |     |             |
|----------------------|-------|-----|-----|-----|-----|-----|-----|-----|-----|-----|-----|-----|-------------|
| MONTH/FY ___ TO DATE | MONTH |     |     |     |     |     |     |     |     |     |     |     | FYTD        |
| TOTAL EMPLOYEES      | Jan   | Feb | Mar | Apr | May | Jun | Jul | Aug | Sep | Oct | Nov | Dec | Comparisons |
| TOTAL LTA'S          |       |     |     |     |     |     |     |     |     |     |     |     |             |
| TOTAL INCIDENT RATES |       |     |     |     |     |     |     |     |     |     |     |     |             |

Figure A-3.—Lost Time Accident Summary Sheet.



# EMERGENCY RESPONSE PLANNING FOR SMALL MINES: WHO NEEDS IT?

By Launa Mallett,<sup>1</sup> Michael J. Brnich, Jr.,<sup>2</sup> and Charles Vaught<sup>1</sup>

## ABSTRACT

This paper discusses emergency response planning with a special emphasis on small minesites. It addresses the importance of an emergency response plan and offers some tips for developing a useful document. The content of the paper is based on U.S. Bureau of Mines research focusing on mine emergency response. Examples from

past mine emergency situations are used to highlight the discussion. The paper is intended to stimulate the thinking of both small mine operators and those safety professionals who work with individuals from small mines. It is not meant to be the final word on emergency response plans.

## INTRODUCTION

Emergencies disrupt organizational routine. By their very nature, they create confusion and uncertainty. The expertise needed to respond effectively may not be common in an organization. One reason is that emergencies, being rare events, demand certain skills that are not developed during normal operations. If no one on site has those skills, the natural confusion and uncertainty will be compounded:

. . . the two owners . . . got there basically about the same time . . . I said, "Hey, . . . we've had a rock fall. We got one guy that's not accounted for. What do we need to do here?" . . . These guys have been in business 20 plus years each, and they had never had nothing like this happen before . . .

The two small mine owners mentioned above had put together a management team that possessed the necessary expertise. They had an experienced safety director who assisted them through a lengthy recovery operation. Is there someone at every small minesite who has that responsibility, experience, and ability? If not, what happens

when the unforeseen emergency occurs? Chaos is likely to be the result.

One of the major factors determining how quickly a situation may be brought under control is the amount of emergency response planning that has been done previously by mine management. Emergency response planning in larger organizations is often done as a matter of course by the safety or training specialist at the mine or by a special team at the corporate office. Small mine personnel do not have these luxuries and must therefore put forth a special effort to prepare themselves for the worst, even while hoping the worst never happens. Because small mines usually have fewer immediate assets to draw upon, this planning becomes especially critical.

The insights about planning contained in this paper come from information that was obtained during U.S. Bureau of Mines (USBM) research that has been conducted over the past 4 years. The work is part of an overall USBM effort to improve the efficiency and effectiveness of emergency response activities and thereby protect potential victims and response personnel. The authors have reviewed literature that addresses all types of emergency response. They have also conducted in-depth interviews with 28 individuals who have extensive experience managing large-scale mine emergencies and 10 people who played key roles in responding to a major mine fire. This paper is based on preliminary analyses of these data.

<sup>1</sup>Research sociologist.

<sup>2</sup>Mining engineer.

Pittsburgh Research Center, U.S. Bureau of Mines, Pittsburgh, PA.



## SOME DEFINING FACTORS OF A SMALL MINE

For the purposes of this paper, a small mine is defined by a number of characteristics that are relevant to emergency response planning and activities. First, a small mine has limited resources, most of which go to production activities. There is little funding or personnel available for emergency response plan research, preparation, and training. The person who is responsible for safety at the mine may also perform a number of other tasks during a workday. This individual therefore has limited time and little (if any) money allocated to planning for a future event that may or may not happen. Second, the work force is small enough that management knows each employee and workers all know each other. If an injury or fatality takes

place, responders know the victim and often also know that person's family. This increases the amount of stress on everyone during a response. A third characteristic of a small mine is local control. In other words, management personnel who conduct daily operations at the minesite will also be accountable for response efforts. There may not be experts from a corporate office who can be called or flown in to assist with decisionmaking. Even when they have a vast knowledge of mining, key decisionmakers at a small mine may have little or no experience with situations they will face during an emergency. All these factors present the operators of small mines with special concerns regarding mine emergency response.

## WHY PLAN FOR EMERGENCIES?

According to the U.S. Mine Safety and Health Administration (MSHA) statistics for the 3-year period 1989-1991, there were 76 miners killed, 138 permanently disabled, and thousands more seriously injured at mines employing 50 or fewer workers. When an incident occurs at a site, there will be an effort to rescue any trapped victims, get medical assistance, clean up the affected area, correct all hazards, and return the mine to production as soon as possible. If each of these activities must be planned as it is conducted, valuable time will be lost and responders who are under stress because of the event may not be able to make the best possible decisions. If emergency response planning is done before an event happens, it will be less difficult and take less time to return the mine to normal operation.

A compelling argument for preplanning comes from a situation created when miners survive the initial impact of an event and need immediate rescue. Take, for example, a roof fall that occurred in Pennsylvania (4).<sup>3</sup> Two miners were attempting to pry down loose top a couple of feet inby permanent supports when the roof came down on them. One worker was covered completely and the other was pinned from his knees down. Crew members removed the rock from these two victims. A miner who was an emergency medical technician (EMT) administered first aid at the scene and sent both victims outside to arriving ambulances. Initial reports stated that both individuals

suffered broken legs. While this was true and one worker eventually recovered completely, the other worker's right leg had to be amputated.

Frequently, self-protection is not the first thing that rescuers think about when someone is in trouble. The State report on this accident does not mention any safety precautions that the rescuers took while trying to remove the victims. It does not tell whether or not the rescuers had been trained to protect themselves in such a situation. It also does not mention the added stress on two of the rescuers; one was the brother of a victim and the other was a cousin. The cousin was the section EMT and was therefore called on to assess both victims' injuries and treat them. The State Bureau of Deep Mine Safety was not officially notified of the accident. While this violation may not be as important as the life and safety of two miners, it is an important response detail that was not dealt with when the event occurred. In this case, rock removal was relatively easy and the victims were soon on their way to a hospital. But, if the roof fall had been larger and the response longer, would the rescuers have been ready? Would the right telephone calls have been made eventually? Would the victims have time to wait for someone to decide what should be done? These questions cannot be answered for this event, but they should be considered at all mines before a serious injury occurs.

## WHAT DOES THE LAW SAY?

A violation was written in the incident cited above because State investigators determined that mine management had not complied with regulations and informed

their agency of the event. While it is not possible here to go through all State regulations pertaining to coal mine emergencies, there are Federal regulations that can be reviewed (6). Both underground and surface mine operators are required by Federal law to be prepared to manage and respond to mine emergencies when they occur.

<sup>3</sup>Italic numbers in parentheses refer to items in the list of references at the end of this paper.

Underground coal mines are covered under regulations in 30 CFR 49, 50, and 75 while surface coal mines and surface areas of underground coal mines are governed by regulations in 30 CFR 50 and 77.

Regulations under 30 CFR 49 (section 49.9) require all underground mine operators to have a mine emergency notification plan. Within this plan, operators must outline procedures that are to be followed for notifying mine rescue teams when their services are required. Copies of the plan must be posted for workers' information and made available to the miners' representative where applicable. Section 50.2 (h) of 30 CFR 50 stipulates the requirements for notifying MSHA of all accidents. Operators of underground mines must also make arrangements for emergency medical assistance and transportation of injured persons, as specified in 30 CFR 75 (section 1713-1). In addition to making these arrangements, the operator must post at appropriate locations the names, titles, addresses, and telephone numbers of all persons or services that are currently under such arrangements to provide medical assistance and transportation.

Section 383 of 30 CFR 75 requires that underground mine operators conduct practice drills to familiarize their miners with emergency escape procedures. At least once every 90 days, each miner, including those with work locations between working sections and main escapeways, is required to participate in a practice drill. During the drill, each miner is required to travel either the primary or alternate escapeway from his or her working section to the point where the split of air ventilating the section intersects with a main aircourse or 608 m (2,000 ft) outby the section's loading point, whichever distance is greater. All other miners are to participate in escapeway drills by traveling at least 608 m (2,000 ft) in either the primary or alternate escapeway from his or her work location toward the nearest escape facility or drift opening.

Besides the 90-day drills, at least two miners from each production section who work on that section and the supervisor must participate in practice drills and travel through the primary or alternate escapeways to the surface, mechanical escape facilities, or to an underground entrance to a shaft or slope to the surface at least once every 6 weeks. In addition, at least two miners and a supervisor on each maintenance shift shall participate in escapeway drills by traveling through the primary or alternate escapeways to the surface, mechanical escape facilities, or to an underground entrance to a shaft or slope to the surface at least once every 6 weeks. In all cases, each escapeway drill cannot be conducted in the same escapeway as the immediately preceding drill. For the 6-week drills, operators are required to systematically rotate personnel to ensure that all miners participate. The practice escapeway drills required under section 383 of 30 CFR 75 may be used to satisfy the evacuation specifications of

fire drills that are required by section 1101-23 of 30 CFR 75. Either before or during practice drills, miners must be informed of the following: the route of escape and any changes to these routes; the location of fire doors, check curtains, or smoke-retarding doors; and the plans for diverting smoke away from mine escapeways.

The remaining regulations that address emergency response for underground mine operators are related specifically to fires. An operator is required to adopt a program for instructing all miners in the use of fire-fighting equipment and in procedures for evacuating their mine (30 CFR 75, section 1101-23). This program, which is submitted to the MSHA district manager for approval, must include a specific fire-fighting and evacuation plan designed to familiarize miners at an operation with procedures for (1) evacuation of workers not needed for fire-fighting activities, (2) rapid marshalling and deployment of necessary personnel, fire-fighting equipment, and rescue apparatus to the fire scene, and (3) operation of fire-fighting equipment at the mine.

Under the provisions of section 1101-23 of 30 CFR 75, mine operators must ensure that at least two workers per section on each production shift are proficient in the use of all fire-fighting equipment available in that section. Those workers are also to know the location of this apparatus in their section. Operators of attended equipment, such as continuous miners and shuttle cars, must be proficient in using the machine's fire-suppression system. On maintenance shifts, the shift foreman and at least one miner for every five working on that shift must be proficient in the use of fire-fighting equipment available in the mine. In addition, they are required to know the location of this equipment.

Section 1101-23 of 30 CFR 75 also compels operators to ensure that all miners employed underground participate in fire drills. These drills, which must take place at intervals of not more than 90 days, are to simulate those actions required by the MSHA-approved fire-fighting and evacuation plan. Mine operators also have to keep a record of all fire drills held at the mine. Finally, mine operators must provide annual instruction, based on the approved plan, to all miners and to newly employed miners within 6 months of their date of employment.

Surface coal mines and surface areas of underground mines are governed by mine emergency response regulations found in 30 CFR 77. While the stipulations of these regulations are similar to those for underground mines, they are considerably less stringent and subject to greater interpretation. Surface operations are required to make arrangements for emergency medical assistance and transportation of persons injured at the mine, as specified in section 1702 of 30 CFR 77. In addition to making these arrangements, an operator must post at appropriate locations the names, titles, addresses, and telephone numbers

of all persons or services that are currently under such arrangements to provide medical assistance and transportation.

There are also regulations specific to fire emergencies. Under 30 CFR 77, section 1100, operators are to provide fire-fighting facilities and equipment based upon the potential fire hazards at each structure or other facility at their mine. Operators must instruct persons working at these facilities and retrain them annually in the use of available fire-fighting facilities and equipment. Surface mines and surface areas of underground mines must have escape and evacuation plans. Section 1101 of 30 CFR 77 specifies that operators are required to establish and keep up to date a specific escape and evacuation plan that is to be followed in the event of a fire. In addition, this plan has to include the designation and proper maintenance of adequate means for exit from all areas where miners or others are required to work or travel. This includes buildings, equipment, and all areas where persons normally congregate during the work shift. In addition, all employees must receive instruction on the escape and evacuation

plans, fire alarm signals, and applicable procedures to be followed in case of a fire.

Therefore, in terms of general emergency response planning, all mine operators are required by law to do the following:

1. Make arrangements for emergency medical assistance and transportation.
2. Post information about medical assistance providers at appropriate locations.
3. Develop evacuation and escape plans.
4. Train miners in evacuation and escape. (Underground mines must also conduct drills.)
5. Develop an emergency plan for notification of mine rescue teams (underground only).
6. Post emergency plan (underground only).

The minimal mine emergency response planning currently mandated by Federal law consists of addressing those regulations that cite details for fire emergency planning (discussed above) and the items listed here.

## **IS MORE NEEDED THAN WHAT IS REQUIRED BY LAW?**

All rules and regulations only specify what is acceptable at a minimum. Policies attempt to ensure compliance under real-world conditions. Strictly adhering to what is legally required in the way of mine emergency planning may offer enough protection for small-scale accidents or situations in which an evacuation can be accomplished easily. When something more serious occurs, however, minimal planning will provide only for minimal activities related to mine evacuation, obtaining medical attention for any injured workers, and calling for assistance from a mine rescue team. There are no requirements to plan for a well-coordinated response that can protect personnel and return the mine to routine production in an efficient manner.

There is a wide range of possible emergencies that can be encountered at a minesite. Many mining companies have not developed formal plans for dealing with these potential events. Instead, they have relied upon the skills of upper level mine managers and others in analyzing and responding to emergencies as they have arisen. In some cases, these informal procedures have worked well and many events have been managed successfully without the use of a formal emergency plan. At the same time, however, managing a mine emergency without a formal plan can pose great risks and result in poor handling of the event. There may be mine emergencies that exceed the technical capabilities of initial responders. In some events, the best technical people can become involved in front-line

rescue or exploratory work when they could be better utilized on the surface. A disaster may incapacitate or kill key management officials. In other cases, the emergency can be of such magnitude that successful management requires sizable outlays for personnel, materials, technical advisors, and services of external organizations. One way to be prepared is to develop an emergency response plan.

An emergency response plan is an all-encompassing document. It covers many aspects of response, including the following: (1) evacuating the mine, (2) setting up site security, (3) dealing with the media, (4) providing information to family members, (5) determining where cars should be parked to lessen traffic problems, and (6) scheduling shifts for workers, including decisionmakers. There are many other aspects of response that should be considered. However, the resulting plan should not be an encyclopedia that is too long and complex to understand. Instead, the plan should be a living document that is kept up to date, is tested and refined during practice, and is useful if it is ever needed. Selected details of what goes into a plan will be discussed in the section "What's Included in an Emergency Response Plan?" The first step in planning, however, is to decide that simple adherence to the laws regarding emergency response will not offer as much protection to a mine and the people who work there as is possible. Next, one must be willing to allocate resources to go that extra step toward being prepared for a large-scale mine emergency.

## HOW IS AN EMERGENCY RESPONSE PLAN DEVELOPED?

When asked whether or not they have a mine emergency response plan, operators often point to a page of instructions hanging by a phone, or to a notebook or manual on a shelf. These documents may, in fact, be the written form of a good plan. But, for the plan to be successfully carried out, it must be more than a document that someone is to refer to when an event occurs. Having a workable plan starts with how it is developed. According to Auf der Heide (*J*), "The process of planning is more important than the written document that results."

A plan should be developed by the individuals who will be involved if it should have to be implemented. In his book "Disaster Response: Principles of Preparation and Coordination," Auf der Heide (*J*) provides several reasons for this. He states that developers will have a better understanding of the plan. They will also know their roles in it. Additionally, personal networking will take place between key responders. The education about emergency response combined with personal relationships people form while writing a plan will prepare them individually for the things they must do if an event occurs. An example of this was given by a safety director who led the planning process for his mine. When a large-scale response was needed, he did not think to refer to the document created. He led the activities based on the education and thinking he had done while creating their response plan:

Sitting down ah, I guess, laying out a format at one time. I did lay out a format for some ah, mines that I was working for, you know, of what to do in case of an emergency; who to call, and what to do . . . As a matter of fact, I'd even made one for this mine, but at that time everything was happening, I didn't even think about it, you know. I had it hanging on the wall. Ah, it was there for everybody to ah, in case of an emergency, to go to. Had the list of all the emergency phone numbers, who to call, who to call first, what information to find out before you call, and so on. And um, it just, like I said, at that time it just, it just went blank that I had that. But I designed it any way, and I prepared it. So it was still in my mind, you know. What I should do.

This responder had learned the plan as it was written and was prepared to carry out the protocols that he had helped develop. At the very least, having individuals with this kind of knowledge and experience at a response will save time and cut down on details being forgotten.

During planning, as mentioned above, connections should be made with organizations and people who will be needed if a large-scale emergency occurs. This includes medical assistance and transportation organizations, mine rescue teams, local law enforcement personnel, equipment suppliers, government regulatory agencies, neighboring mines, and others according to local situations. Asking these people to meet during a nonemergency period is also an important aspect of the planning process: According to Auf der Heide (*J*), "A number of researchers have observed that predisaster contacts among representatives of emergency organizations result in smoother operations in subsequent disasters. . . Furthermore, in the process . . . participants become familiar with the roles of other individuals and organizations involved in the disaster response."

Agreements for sharing resources between neighboring mines during an emergency may be made in the planning process. As one safety director, reflecting on an experience at his mine, relates:

You're going to have to have um, accesses to get equipment. . . Such equipment as extra scoop, or mantrips ah, due to your battery power being exhausted, and not having time to recharge, due to it being traveled in and out.

. . . call . . . someone [at a local mine] up and say, "Hey, . . . in case of emergency, if I need a . . . This might never happen, but um, if I was to need you to bring me supplies, or borrow your truck or something . . . Just, you know, for my sake, can I feel comfortable calling you and say I can borrow your truck, or that you'll go to the store for me." . . . I'd have it like that.

Setting up these relationships prior to an event will save time if such resources are ever needed. Of course, the better these agreements are worked out beforehand, the more effective they will be.

Proper planning will result in experienced personnel and a more easily coordinated response. In terms of coordinating the various individuals and agencies who are involved in a response, having a smaller mine in a more rural area might be a plus. There may be fewer organizations and individuals to coordinate, and it is likely that the people who respond will already know each other. This will cut down on the possibilities for miscommunications and could shorten the time that it takes for responders to know who is playing what role.

## WHAT'S INCLUDED IN AN EMERGENCY RESPONSE PLAN?

Adequate mine emergency response plans need to be suitable for use in managing any situation that could arise at a mine. These range from easily foreseen predicaments, such as fires, explosions, inundations, or roof fall entrapments, to even the least probable event, such as a hazardous chemical spill near an intake. If a mine emergency plan is well prepared it can cover the worst foreseeable situation. And, if it is designed to utilize all available resources to achieve predefined objectives, then it is likely that the basic plan can be adapted to cover a wide range of possible emergency situations. The scope of this paper does not permit the presentation of detailed descriptions of all of the elements of a mine emergency plan. This section, however, provides insight regarding some of the major components that comprise a basic mine emergency response plan. The ideas presented were taken from the interviews discussed above and from related literature (5, 7).

*Plan Objectives.*—A mine emergency plan must contain clearly defined objectives for each portion. If objectives are considered carefully and defined as an integral part of planning, then all individuals engaged in developing the plan, training in its use, or implementing it in an emergency will be better prepared to respond. Quite often, major events are handled initially by individuals who have little or no experience in dealing with a mine emergency. Determining the objectives and stating them within the plan helps personnel with less knowledge and experience deal with the emergency.

*Initial Response to the Emergency.*—As soon as possible after the onset of an emergency, certain tasks should be done. These items should be listed explicitly in the plan. Some things that the mine operator needs to consider having on this list follow:

1. Determine if miners are trapped or missing and if they have been communicated with.
2. Ascertain the exact nature of the emergency and its location in or about the mine.
3. Notify mine rescue teams if necessary.
4. Notify emergency medical services, hospitals, rescue squads, fire department, or other outside services if they are needed.
5. Notify Federal and State regulatory agencies.
6. Initiate fire-fighting or rescue-and-recovery operations.
7. Determine if all mine fans are still operating.

*Command Center and Other Facilities.*—Workplaces should be available for use by a number of individuals on the surface. These include company personnel, officials

from State and Federal agencies, miners' representatives, and others who will be involved in directing a response to the emergency. An area needs to be set aside to serve as the command center. Space may also be required for meetings and briefings, servicing mine rescue equipment, first aid administration, a temporary morgue, and other functions.

*Definition of Roles and Responsibilities.*—Each person who will be participating in handling an emergency, from rank-and-file workers to the mine manager or superintendent, needs to know exactly what his or her responsibilities are during this event. Roles should be so well defined that any qualified person can be assigned any position and know what the associated duties are. This may be accomplished by developing task cards—pocket-size cards that clearly define the duties and responsibilities for each position. The cards can be distributed to responders, who will carry and refer to them at any particular moment during a situation. This will ensure that they have properly attended to all assigned duties.

*Rotation of Commanding Personnel.*—Depending on the nature of a mine emergency, company officials may be required to be at the scene for several days. In one reported case, a mine superintendent worked 37 h straight at a mine fire before leaving the command center (8). Research has shown that lack of adequate rest severely inhibits a person's ability to make quality decisions. Poor decisions in a mine emergency can jeopardize the lives of responders at the scene and/or severely hamper efforts to deal with the event. Company officials need to make arrangements for rotation of command personnel at the emergency site to ensure that those individuals who will be required to make critical decisions are well rested.

*Activities Logging.*—At least until additional personnel arrive at a scene, the company should assign someone on the surface to maintain a log of all rescue and recovery activities. This log should be detailed and include all major activities that have occurred since the onset of the emergency.

*Fan Operation.*—When required, the mine operator should have all surface fans examined to determine their condition. The operator should assign a person to each operating surface fan to ensure its continued operation.

*Property Entrance Restriction-Security.*—The operator should, as part of planning, establish a policy restricting entrance to authorized personnel in the event of a mine emergency. Only those required to handle the situation should be permitted on mine property. Guards should be assigned at each mine entrance. Often, local law enforcement agencies will provide officers to fill this job.

*Mine Maps.*—Up-to-date mine maps will usually be needed for use by mine rescue teams, company officials, and others. A sufficient number of current mine maps or prints should be secured and made ready for distribution.

*Supplies and Equipment.*—Depending on the nature of a particular mine emergency, supplies such as crib blocks, timbers, brattice curtain, concrete blocks, water line, rock dust, and other articles may be needed in quantity very quickly. In the event of a mine fire or explosion, materials such as ready-mix concrete, steel plates, wood, and stone or gravel may be required for sealing the mine. Liquid carbon dioxide may be needed in an attempt to smother a fire. Provision should be made with suppliers and other mining operations to provide these items on short notice when needed. Machinery such as scoop tractors, auxiliary fans, foam generators, power centers, pumps, front-end loaders, bulldozers, drill rigs, and other equipment and tools may have to be brought on site quickly. Arrangements should be made in advance with company purchasing agents and suppliers of this equipment to ensure quick delivery to the minesite of these and all other necessary items.

*Interacting With the Media.*—Any major mine emergency will draw attention very quickly. In a matter of hours, media representatives will be at the scene to obtain current information about the situation. It is important to determine beforehand how the media is to be dealt with and who will interact with them to ensure dissemination of accurate information. One group of small mine owners are looking to their operators association for support in this area (2). During a response, mine management keeps the operators association staff updated and tells all media representatives to go to that staff for information. The association staff then prepares press releases and handles all inquiries from the media. Whether the media is to be handled by mine personnel or by some designated representative should be decided and communicated before an event occurs.

*Needs of Personnel on the Scene.*—If a number of responders are required on the scene of a mine emergency for a long period of time, arrangements should be made to provide these individuals with sleeping quarters, food, and other essentials. Agreements can be made in advance with area motels to provide lodging. Local restaurants and grocery stores can be commissioned to provide food as needed.

*Needs of Relatives and Friends.*—When an emergency occurs, relatives and friends of miners working at the operation may arrive on site seeking information about loved ones. Mine officials should prepare to deal with relatives and friends by providing them with the latest factual information available. If possible, there should be arrangements to have counselors and clergy available to interact with family members during the emergency. A suitable facility might be necessary for family members who wish to remain on site during the response.

*Special Needs of Response Personnel and Others Involved.*—In a mine emergency, workers and rescue personnel are faced with numerous situations that may result in severe emotional stress and trauma (3). This condition, called critical incident stress, can frequently result in short- or long-term emotional difficulties that affect one's ability to function. There should be arrangements to have counselors, trained in critical incident stress debriefing (CISD), available for workers who witnessed or were involved in the emergency. These counselors could also assist individuals who participated in the response. CISD is a technique for helping normal people cope with stress associated with abnormal events.

*Communications.*—Communications is one of the most crucial elements in managing a mine emergency. Quality communication links are needed between a command center and the emergency location. There must also be good links between a command center and facilities away from the minesite. An operator needs to assign a person to ensure that mine telephones or other communication systems are in place and working. It is not uncommon for a mine to have only one telephone line servicing the operation. Depending on the nature of an emergency however, additional telephone lines may be needed. The capability to add additional lines during an emergency should be prearranged with the telephone company.

The purpose of this portion of the paper was to stimulate thinking by illustrating some of the many items that must be dealt with during a mine emergency. The elements of a mine emergency response plan that have been mentioned are but a few of the many components that could comprise a quality effort. An important point to remember is that the time to plan for a mine emergency is before an event occurs rather than in the middle of a situation.

## IS HAVING A WRITTEN DOCUMENT ENOUGH?

When the planning process has resulted in a final document—a mine emergency response plan—then the next phase of preparation begins. Everyone who works at the minesite should be trained in the plan's contents. They

should also be introduced to the various roles included. Individuals must know what they are likely to be asked to do if the plan were put into use. They should also be aware of company policy on response issues such as site

security and interactions with the media. If possible, miners and responders should be given an opportunity to practice carrying out the plan or, at least, some portion of it. Less direction and coordination will be needed to start up a response if more people are trained to follow the plan. During training, the plan will also be tested and can be revised and refined to match minesite demands.

Preparation for a large-scale emergency should be an ongoing process. Telephone lists and mine maps should be updated routinely. Newly hired workers should be introduced to the mine emergency response plan before

they start to work. On occasion, everyone should be reminded of the plan and of their role(s) in it. When there are changes to a mine, mine management, or local resources, the plan should reflect those changes. The result would be a work force that is more confident of management's commitment to their safety, inspectors who see that the extra step has been taken at this site, and responders and decisionmakers who are better prepared. If the worst happens, management will know that every effort was made to make an emergency response as efficient and effective as possible.

## CONCLUSIONS AND RECOMMENDATIONS

As discussed previously, large-scale mine emergencies are infrequent events, and so it is difficult to put daily concerns aside to focus attention on them. They do, however, occur with results that can be devastating economically for the mining operation, and economically as well as emotionally for the individuals involved. These consequences can be mitigated with even limited emergency response planning. Planning is particularly important for small mining operations that will need to call on outside help to mount a sizable response.

There are a number of resources available at little or no cost to the small mine operator who wants to begin planning for a mine emergency. One place to begin is with the sample emergency response plan provided in the appendix to this paper. The plan is a simplified version of one prepared for and being used at an underground coal mine. It could be used as a model for the development of a site-specific plan.

Another source of information is the National Mine Health and Safety Academy at Beckley, WV. The academy is devoted to mine safety training and has both written material and classes on emergency response topics. There is also a fire school on the grounds where miners are trained to fight underground fires. Information about classes being taught at the academy can be obtained by calling the Instructional Services Office at 304-256-3211. Written materials are promoted in a catalogue, which is available through the Business Office at 304-256-3257.

Assistance is also offered through the Center for Emergency Preparedness, West Virginia University Mining Extension, in Morgantown, WV, at 304-293-4211. Like the academy, the center has written materials available and conducts training related to emergency response. Staff members also act as consultants conducting fire audits for mining companies.

Local resources should not be forgotten. Local experts may be needed during an emergency, and those individuals will be happy to help. The best time to meet with these people and coordinate planning efforts is during the planning process. Local law enforcement may be called on to provide site security and should be familiar with the site and the individuals who will be in charge. Ambulance crews and other medical personnel should be contacted so that their part in the response will go smoothly. The American Red Cross or a local civic group may be willing to coordinate activities, such as feeding responders and making family members as comfortable as possible. A church, school, or community center may have rooms that could be used as offices or a press briefing area. It will be much easier for community members to assist in a response if their tasks are defined before an event occurs. The probable needs should be considered and then resources sought to fulfill them. The telephone calls and/or meetings to set up this coordination of resources may save a considerable amount of time and energy and decrease confusion inherent in the situation if a response ever needs to be put in place.

## REFERENCES

1. Auf der Heide, E. Disaster Response: Principles of Preparation and Coordination. C. V. Mosby Co., Baltimore, MD, 1989, pp. 34-48.
2. Gooch, D., and K. Myers. Crisis Communications Manual. Coal Operators & Assoc., Inc., Pikeville, KY, undated, 13 pp.
3. Kowalski, K. M. A Missing Component in Your Emergency Management Plans: The Critical Incident Stress Factor. Paper in Proceedings of the 1994 International Emergency Management and Engineering Conference (Miami, FL, Apr. 18-21, 1994). Simulation Councils, Inc., in press.
4. Lehman, D. A., and E. R. Pauley. Accident Investigation Report: Nonfatal Roof Fall Accident. Federal Mine I.D. No. 06289, June 6, 1989. Commonwealth of Pennsylvania, undated.

5. **Safety in Mines Testing and Research Station. Training of the Officials for the Underground Coal Mining Industry. V. 2, 1989, pp. 4-1 to 4-8.**

6. **U.S. Code of Federal Regulations. Title 30—Mineral Resources; Chapter I—Mine Safety and Health Administration, Department of Labor; Subchapter O—Coal Mine Safety and Health; Part 75—Mandatory Safety Standards—Underground Coal Mines; Part 77—Mandatory Safety Standards—Surface Coal Mines and Surface Work Areas of Underground Coal Mines, July 1, 1993.**

7. **U.S. Mine Safety and Health Administration (Dep. Labor). Advanced Coal Mine Emergency Operations—Student Text Material and Instructor's Guide. Undated, 80 pp.**

8. **Vaught, C., and D. G. Wooten. Responding to an Underground Mine Fire: A Case Study. Paper in Proceedings of the Twenty-Third Annual Institute on Mining Health, Safety, and Research (Blacksburg, VA, Aug. 24-26, 1992). Dep. Min. and Miner. Eng., VA Polytech. Inst. and State Univ., Blacksburg, VA, 1992, pp. 197-208.**



## APPENDIX.—SAMPLE EMERGENCY RESPONSE PLAN

### Weplan Mining Company Mine Emergency Preparedness Plan

#### Introduction

Although substantial improvements in the technical aspects of mining and improved examinations have been made, mine emergencies continue to occur. Because of this fact, we must continue to search for the safest methods to obtain the best results using training and planning skills, and being prepared for positive response in the event of an emergency.

A combination of actions in an emergency many include all of the following:

1. Hazard Control: The immediate action to eliminate the hazard or limit its scope.
2. Evacuation: The orderly exit of miners from affected areas, using designated escape routes, and emergency breathing devices.
3. Survival: Alternate means of survival, such as barricading, when escape routes are blocked.
4. Rescue: The efforts by those outside the mine to locate, communicate with and remove those miners trapped underground.
5. Recovery: The effort to recover missing persons and return the mine to operational or investigative status once conditions permit.

Confusion and disorder after discovery of an emergency is normal. The first few minutes after discovery are crucial. Since almost all emergencies are unique, a program detailing every situation is not possible. However, there are certain elements common to all and the preparation of a written plan can minimize the confusion and disorder associated with the emergency. This program is intended to offer some basic guidelines for responding when an emergency occurs.

Some elements included are:

1. Communications and notifications immediately after discovery of an emergency and at certain intervals thereafter.
2. Responsibilities of certain personnel during the emergency.
3. Selection of a person to be in overall control.
4. Development of an advisory and control group.
5. Evacuation and survival procedures.

6. Rescue and recovery procedures.
7. Surface organization, facilities, and outside sources of assistance for support purposes.
8. Control of outside elements with an interest in the emergency, but not involved with the operation such as news media, relatives and the general public.

It is intended that all persons who have a part in the emergency will review the entire plan and be aware of the contents. If anything is noted that should be changed, it should be brought to the attention of "the Safety Department" for revision as necessary.

Waiting until an emergency to review this plan may be too late to organize an effective emergency operation. Study it frequently.

## INSTRUCTIONS

The actions taken in this manual are color coded.

When implementing any step of these instructions, identify the color highlighted and turn to the corresponding color tab for detailed information.

*[In the original plan, the underlined words in the following summary were highlighted with colors. The notebook which held the plan included corresponding color tabs. These tabs separated sections consisting of detailed information on each item and blank forms that would be needed to complete the tasks. Headings are used here instead of the colors.]*

**UNDERGROUND MINE EMERGENCY PLAN**

Upon notification or indication of a mine emergency:

**IMMEDIATELY...**

1. Initiate Event Log
2. Notify personnel adversely affected and document their intentions
3. Notify on-site person in charge
4. Activate on-shift mine emergency or fire fighting procedures

**PRIOR TO 15 MINUTES**

1. Initiate mine monitoring procedures
2. Notify personnel outby affected area for evacuation or assistance
3. Notify person in charge of mine
4. Notify person in charge of safety
5. Notify critical company manpower

**PRIOR TO 1 HOUR**

1. Evaluate underground conditions
  - A. Determine emergency location and extent
  - B. Effect of emergency on evacuation, escape and barricading
  - C. Determine fire fighting, mine rescue or other emergency needs
2. Evaluate underground utilities
  - A. Communications
  - B. Ventilation
  - C. Power
  - D. Water
3. Initiate check-in/check-out procedures
4. Provide critical supplies
5. Notify Mine Rescue Team
6. Notify Fire Brigade

7. Notify EMT's on shift and other medical assistance as needed
8. Notify essential manpower
9. Notify MSHA
10. Notify State Division of Mines
11. Notify Local Law Enforcement

**PRIOR TO 4 HOURS**

1. Activate gas sampling and fan evaluation procedures
2. Provide essential supplies and services
  - A. Shop
  - B. Engineering
  - C. Other Corporate operations
  - D. Other mines
  - E. Vendors
3. Activate control group organization
4. Notify additional fire brigade members or mine rescue teams
5. Provide for technical assistance from other corporate operations and other local mines

**AFTER 4 HOURS**

1. Activate advisory group organization
  2. Provide additional outside communications
  3. Provide maximum number of mine emergency teams needed
  4. Activate facility needs procedures
    - A. Control Group area
    - B. Advisory Group area
    - C. Mine rescue briefing area
    - D. Mine rescue benching area
    - E. Mine rescue housing
    - F. Family relations area
    - G. Press and public relations area
  5. Provide necessary supplies and services
    - A. Food services arrangements
-

B. Press and family briefing procedures

6. Initiate mine rescue logs

Mine Emergency  
Weplan Mining Company

| WHEN                | INITIATE                   | WHO   | WHERE  | HOW                                | TIME COMPLETED |
|---------------------|----------------------------|---|--|------------------------------------|----------------|
| Immediately         | Event Log                  | Person who learns of problem until assigned person takes over | Logs and Records Form - See Page 2                         | As Events Occur                    |                |
| Prior to 15 minutes | Mine Monitoring            | Assigned person   | Fan Underground  | Mine Monitors                      |                |
| Prior to 1 hour     | Check-In and Check-Out Log | Assign person at Operations Center                            | Logs and Records See Page 3 Operations Center              | Utilize Log for Response Personnel |                |
| After 4 hours       | Mine Rescue Team Logs      | Advisory Group  | Mine Rescue Briefing Room Area Logs and Records See Page 4 | Per Available Mine Rescue Teams    |                |









Mine Emergency  
Weplan Mining Company

| WHEN                | NOTIFY  | WHO   | WHERE                             | HOW   | TIME COMPLETED |
|---------------------|---|---|-----------------------------------|---|----------------|
| Immediately         | Persons Affected  | Working Sections and Outby Crews                  | "Sections"                        | Mine phone, Electrical Power, Belt Shutdown |                |
| Immediately         | On site person in charge or person outside  | Mine Superintendent or Maintenance Superintendent | Operations Center, or in the Mine | Mine phone, Electrical Power, Belt Shutdown |                |
| Prior to 15 minutes | Persons outby affected area   | Working Sections and Outby Crews                  | Throughout the Mine               | Mine phone, Physical Inspection             |                |
| Prior to 15 minutes | Person in charge of Mine (Call until one is reached, then go to Safety list)              | "Names"   | Home Work                         | "Phone #"<br>"Phone #"                      |                |
| Prior to 15 minutes | Person in charge of Safety (Call until one is reached, then go to Critical Manpower list) | "Names"   | Home Work                         | "Phone #"<br>"Phone #"                      |                |

NOTIFICATION  
Page 2

| WHEN                | NOTIFY   | WHO  | WHERE  | HOW  | TIME COMPLETED |
|---------------------|--|--|--|--|----------------|
| Prior to 15 minutes | Critical Company Manpower (Do not repeat if notified above)                                  | "Names"  | Home Work  | "Phone #"<br>"Phone #"   |                |
| Prior to 1 hour     | Mine Rescue Team Members   | "Names"  | Home Work  | "Phone #"<br>"Phone #"   |                |
| Prior to 1 hour     | Fire Brigade Team Members  | "Names"  | Home Work  | "Phone #"<br>"Phone #"   |                |
| Prior to 1 hour     | Emergency Medical Technicians or other medical assistance as needed                          | "Names"<br>Local Ambulance   | Mine Site Hospital   | Mine Phone<br>"Phone #"  |                |
| Prior to 1 hour     | Essential Manpower as instructed or as needed  | "Names"  | Home   | "Phone #"  |                |
| Prior to 1 hour     | Company personnel  | "Names"  | Home Office  | "Phone #"<br>"Phone #"   |                |
| Prior to 1 hour     | MSHA<br>Note: should be called in order by a Safety or Mine official until one is contacted. | "Local" Office<br>Field Office<br>Subdistrict Office<br>District Office<br>Response Coord. -<br>Ron Keaton | "Location"<br>"Location"<br>"Location"<br>"Location"<br>Morgantown, WV | "Phone #"<br>"Phone #"<br>"Phone #"<br>"Phone #"<br>304-296-2079 |                |

| WHEN             | NOTIFY  | WHO  | WHERE                                  | HOW                                 | TIME COMPLETED |
|------------------|---|--|--|-------------------------------------|----------------|
| Prior to 1 hour  | State Mine Officials<br>Note: Should be called in order by a Safety or Mine official until one is contacted | "Main Office"<br>Emergency Number<br>"Names" | "Location"<br>"Location"<br>"Location" | "Phone #"<br>"Phone #"<br>"Phone #" |                |
| Prior to 1 hour  | Local Law Enforcement as needed   | Sheriff's Office                             | "Location"                             | "Phone #"                           |                |
| Prior to 4 hours | Additional Mine Rescue and Fire Brigade Teams   | "Team Names"                                 | "Location"                             | "Phone #s"                          |                |

Mine Emergency Plan  
Weplan Mining Company

| WHEN             | ACTIVATE                                   | WHO                   | WHERE                    | HOW                                     | TIME COMPLETED |
|------------------|--|-----------------------|--------------------------|---|----------------|
| Immediately      | Mine Emergency Procedure                   | Underground Personnel | At or Inby Affected Area | Fire Fighting and Evacuation Procedures |                |
| Prior to 4 hours | Gas Sampling and Fan Evaluation Procedures | "Name"                | Fans and Sampling Points | Mine Monitor and Detectors Sample Bags  |                |
| Prior to 4 hours | Control Group Organization                 | "Names"               | Command Center           | Command System Structure                |                |
| After 4 hours    | Advisory Group Organization                | "Names"               | Advisory Group Location  | "Phone #"                               |                |
| After 4 hours    | Command Center                             | "Name"                | Operations Center        | See Procedures                          |                |
| After 4 hours    | Advisory Group Area                        | "Name"                | "Location"               | See Procedures                          |                |
| After 4 hours    | Mine Rescue Brigade Area                   | "Name"                | "Location"               | See Procedures                          |                |
| After 4 hours    | Mine Rescue Benching Area                  | "Name"                | "Local Hotels"           | See Procedures                          |                |

ACTIVATE  
Page 2

| WHEN          | ACTIVATE                        | WHO    | WHERE      | HOW            | TIME COMPLETED |
|---------------|---------------------------------|--------|------------|----------------|----------------|
| After 4 hours | Mine Rescue Housing             | "Name" | "Location" | See Procedures |                |
| After 4 hours | Family Relations Area           | "Name" | "Location" | See Procedures |                |
| After 4 hours | Press and Public Relations Area | "Name" | "Location" | See Procedures |                |

## Weplan Mining Company Facility Needs Procedures

1. Command Center

|               |  |
|---------------|--|
| Building Name |  |
| Location      |  |
| Phone Number  |  |

2. Staging Area for Teams

|               |  |
|---------------|--|
| Building Name |  |
| Location      |  |
| Phone Number  |  |

3. Work Area for Apparatus Maintenance

|               |  |
|---------------|--|
| Building Name |  |
| Location      |  |
| Phone Number  |  |

4. Briefing Area for Teams

|               |  |
|---------------|--|
| Building Name |  |
| Location      |  |
| Phone Number  |  |

5. Waiting Area for Relatives and Friends

|               |  |
|---------------|--|
| Building Name |  |
| Location      |  |
| Phone Number  |  |

6. Press Room and Information Center

|               |  |
|---------------|--|
| Building Name |  |
| Location      |  |
| Phone Number  |  |

7. Food and Sleeping Quarters

|               |  |
|---------------|--|
| Building Name |  |
| Location      |  |
| Phone Number  |  |

# Weplan Mining

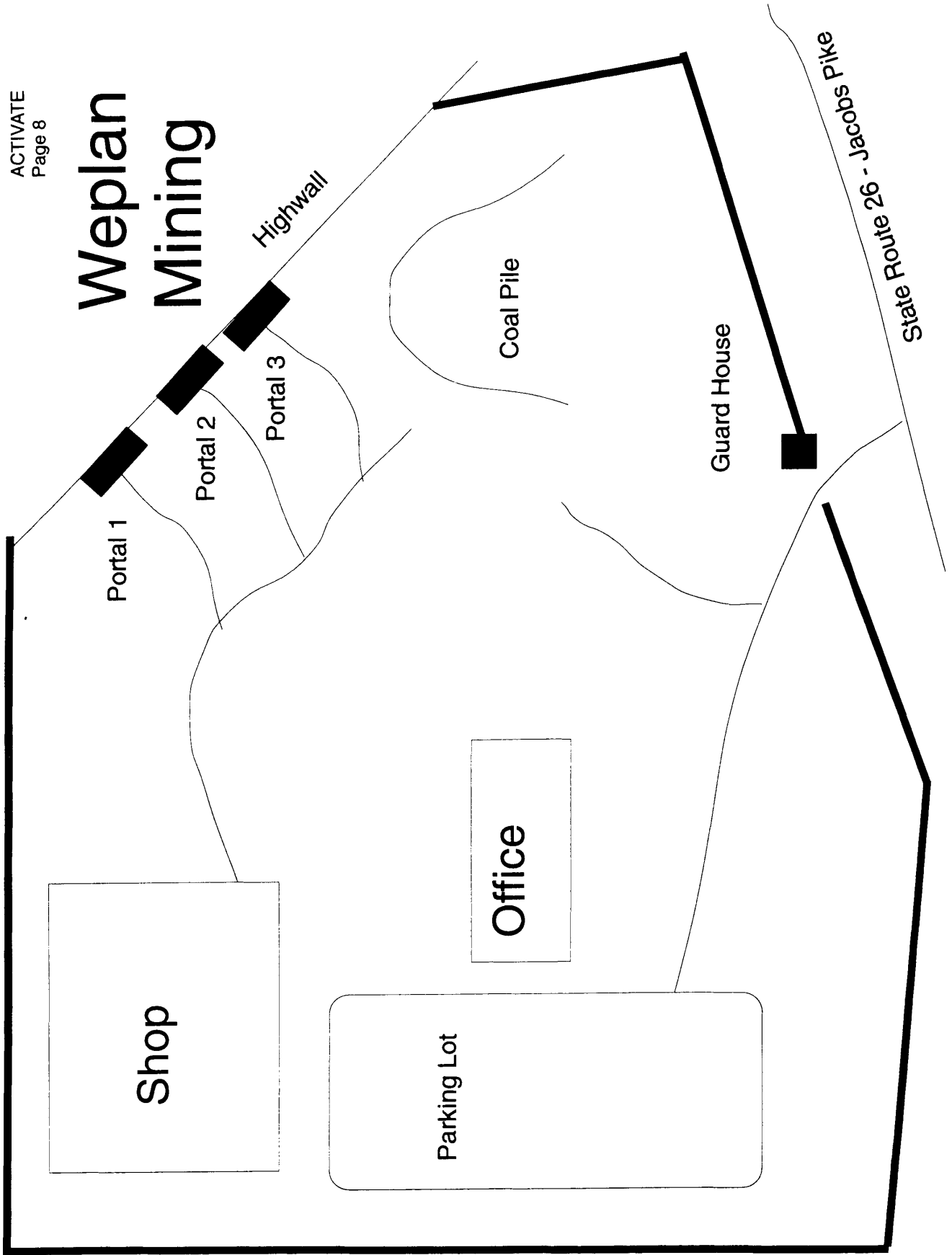



**Mine Emergency  
Evaluate Conditions for Decision Making  
Weplan Mining Company**

| WHEN            | EVALUATE   | WHO                      | WHERE                     | HOW   | TIME COMPLETED |
|-----------------|--|--------------------------|---------------------------|---|----------------|
| Prior to 1 hour | 1. Emergency location and extent<br><br>2. Effect of emergency on evacuating and barricading<br><br>3. Firefighting, Mine Rescue, or other emergency needs | Person in charge of mine | Mine monitor or mine site | 1. Review event log<br><br>2. Review notification log<br><br>3. Review Current Monitoring - CO levels and their locations<br><br>4. Prior monitor print-outs<br><br>5. Mine maps at display board |                |

| WHEN            | EVALUATE                    | WHO  | WHERE   | HOW   | TIME COMPLETED |
|-----------------|-----------------------------|--|---|---|----------------|
| Prior to 1 hour | Communications capabilities | Person in charge of mine or designate<br>Facility technician<br>Electrical Foreman | Mine site or mine monitor<br>Facility tech office | <ol style="list-style-type: none"> <li>1. Test phones               <ol style="list-style-type: none"> <li>a. Operations center to underground</li> <li>b. Operations center to mine monitor</li> </ol> </li> <li>2. Fire alarms<br/>Mine monitor to underground</li> </ol>   |                |
| Prior to 1 hour | Ventilation                 | Person assigned by person in charge of mine<br>"Name"                              | Mine monitor<br>Main Fan<br>Borehole Fan          | <ol style="list-style-type: none"> <li>1. Current monitoring               <ol style="list-style-type: none"> <li>a. fans on/off</li> <li>b. fans status</li> </ol> </li> <li>2. Physical inspection               <ol style="list-style-type: none"> <li>a. Pressure recorder (mine monitor)</li> <li>b. Gas detection with CMX 270</li> <li>c. Other operation status</li> <li>d. Appearance of exhausting air</li> </ol> </li> </ol> |                |

EVALUATE  
Page 3

| WHEN            | EVALUATE         | WHO  | WHERE   | HOW   | TIME COMPLETED |
|-----------------|------------------|--|---|---|----------------|
| Prior to 1 hour | Electrical Power | <ol style="list-style-type: none"> <li>1. Person assigned by person in charge of mine</li> <li>2. Electricians, "Names"</li> <li>3. Facility Technician</li> </ol> | <p>Mine</p> <p>Mine monitor</p>                                   | <ol style="list-style-type: none"> <li>1. Physical check of outside and underground power</li> <li>2. Current mine monitoring</li> </ol>  |                |
| Prior to 1 hour | Water System     | <ol style="list-style-type: none"> <li>1. Person assigned by person in charge of mine</li> <li>2. "Name"</li> <li>3. Mine monitor operator</li> </ol>              | <p>Outside water storage (tank and ponds)</p> <p>Mine monitor</p> | <ol style="list-style-type: none"> <li>1. Physical inspection               <ol style="list-style-type: none"> <li>a. levels</li> <li>b. rate of drop</li> </ol> </li> <li>2. Current mine monitoring</li> <li>3. Check sprinkler alarms</li> </ol> |                |

Mine Emergency  
Provide for Materials and Equipment  
Weplan Mining Company

| WHEN            | PROVIDE  | WHO   | WHERE   | HOW  | TIME COMPLETED |
|-----------------|--|---|---|--|----------------|
| Prior to 1 hour | 1. Fire fighting                                 | Assigned persons  | 1. Underground<br>a. section safety trailer<br>b. outby locations<br><br>2. Warehouse | Deliver to emergency site                                |                |
| Prior to 1 hour | 2. Foam generator and foam                       | 1. Persons assigned<br><br>2. Fire brigade members                              | Electrical Shop   | 1. Deliver to portal<br><br>2. Deliver to emergency site |                |
| Prior to 1 hour | 3. First aid and/or medical assistance if needed | 1. Facilities technician<br><br>2. Person in charge<br><br>3. Safety department | 1. Warehouse<br><br>2. Mine monitor room<br><br>3. Command center                     | 1. Dispatch ambulance to mine site<br><br>2. EMT list    |                |
| Prior to 1 hour | 4. Gas detection supplies                        | 1. Assigned person<br><br>2. Safety Department                                  | Safety Office   | Deliver to operations center                             |                |

PROVIDE  
Page 2

| WHEN             | PROVIDE                                       | WHO   | WHERE  | HOW   | TIME COMPLETED |
|------------------|---|---|--|---|----------------|
| Prior to 1 hour  | 5. Respiratory protection SCSR                | Assigned person   | 1. Operations center/mantrips<br>2. Warehouse  | Deliver to operations center                      |                |
| Prior to 1 hour  | 6. Mine rescue breathing apparatus            | Qualified mine rescue team member if available  | Mine rescue station  | Quick bench and respond with or without full team |                |
| Prior to 1 hour  | 7. Ventilations supplies and/or urethane foam | Person assigned   | Warehouse  | Deliver to emergency location                     |                |
| Prior to 4 hours | Essential supplies and services               | 1. Warehouse/<br>purchasing -<br>"Names"<br>2. Engineering -<br>"Names"<br>3. Other Corporate<br>Operations<br>4. Other Mines<br>5. Vendors | Warehouse<br><br>Office<br><br>"Mine Names -<br>Contact Person"<br><br>"Mine Names -<br>Contact Person"<br><br>"Vendor List" | "Phone #"   |                |
| Prior to 4 hours | Chromatograph analysis                        | "Name"  | "Location"   | "Phone #"   |                |

| WHEN             | PROVIDE  | WHO     | WHERE                                 | HOW                        | TIME COMPLETED |
|------------------|--|---------|---------------------------------------|----------------------------|----------------|
| Prior to 4 hours | Technical assistance from corporate office   | "Names" | "Location"                            | "Phone #"                  |                |
| After 4 hours    | Additional outside communication   | "Names" | "Location"                            | "Phone #"                  |                |
| After 4 hours    | Maximum number of mine rescue teams  | "Names" | See Notification Procedure            | See Notification Procedure |                |
| After 4 hours    | Necessary supplies and services<br><br>1. Food service<br><br>2. Press and family briefing procedure | "Names" | Family facility<br><br>Press facility | "Phone #"                  |                |

# EXPERIMENTAL TRAINING TO REDUCE VARIABILITY IN THE INTERPRETATION AND APPLICATION OF MACHINE GUARDING REQUIREMENTS

By Lynn L. Rethi<sup>1</sup> and William J. Wiehagen<sup>2</sup>

---

## ABSTRACT

The use of machine guards for industrial equipment is commonly accepted as a primary means of injury prevention. Often the interpretations of rules pertaining to machine guarding lead to a variety of guarding applications at the worksite. The consequences of this variability between regulatory intent and practice are evidenced by the frequency of guarding citations by inspectors, litigation seeking to ameliorate judgment of the inspectors, injuries that may be sustained because of workers' misunderstanding of safe guarding practices, misinterpretations of guarding requirements, or failure to comply with guarding mandates.

Training is a common method used for reducing this variability. This paper describes a U.S. Bureau of Mines-developed training intervention that might begin to define and identify this variability within the inspectorate, work force, or management. The fidelity of the training is enhanced through the use of three-dimensional slides and the structure of the classroom exercise. The classroom simulation moves beyond traditional safety training by offering an opportunity to apply general guarding rules and regulations to a specific situation. It is suggested that this type of training may be useful in defining and seeking solutions to the apparent variability in both the interpretation and application of guarding requirements.

## INTRODUCTION

The reason behind a machine guard seems simple enough—to prevent employees from coming in contact with moving parts. The method of providing that protection appears equally simple—install a barrier. Machine guarding is not a new concept. The first patent issued for a machine guard was registered in 1868 (1).<sup>3</sup> Since then, the guarding of moving parts has become much more sophisticated. A major influence on present machine guarding practices was the Occupational Safety and Health Act of 1970 (OSHAct) (2). Within a few years of the OSHAct,

the National Safety Council asserted: "One of the major goals of the [Act] is the guarding of all machinery and equipment to eliminate personnel hazards created by point of operations, in-going nip points, rotating parts, flying chips and sparks. These hazards have been responsible for countless numbers of injuries, and fatalities of personnel. **If the now required guarding had been required back then [prior to the OSHAct], many if not most of these accidents might have never occurred and even . . . [the Act itself] would probably not be the law of the land**" (3). These remarks imply a widely accepted recognition of the importance and application of machine guarding requirements.

What can be done today to better apply a proven technique for loss prevention? While the solution may be elusive, the U.S. Bureau of Mines (USBM) conducted this research to learn more about the sources of variability

---

<sup>1</sup>Training research specialist.

<sup>2</sup>Industrial engineer.

Pittsburgh Research Center, U.S. Bureau of Mines, Pittsburgh, PA.

<sup>3</sup>Italic numbers in parentheses refer to items in the list of references at the end of this paper.

between guarding theories, regulations, and everyday practice. This approach would involve the collection of data. These data could define the variability within the inspectorate, management, and work force concerning the practical understanding and application of guarding requirements. Defining variability, through structured training experiments, may lead to a shift in the way one thinks about traditional safety training. These "training

experiments," in defining variability, may lead to innovations in guarding practices, work procedures, and training protocols. Benefits could include a further reduction in the number of injuries related to improper guarding practices, reduced levels of violations, and lesser reliance on the judicial system to resolve a variety of interpretations of machine guarding regulations.

## EVIDENCE OF VARIABILITY

Although the sensible notion of "good guarding practices" is fairly common within general industry, other factors suggest that variability exists in the regulatory interpretation and use of machine guards at the workplace. How can this variability be described? Does it fall within the literature relating to perception and recognition, motivation, judgment and decisionmaking, ergonomic design, or the adherence of workers to safe job procedures? Understanding and describing this variability may offer insight to solutions that embody all these concepts. This knowledge could assist in the design of training, the design of guarding components, or regulatory policy. The evidence of variability is manifested by the information obtained from injury reports, legal controversies, and violations-citations associated with machine guarding practices.

### INJURY DATA

One important consequence of variability between regulatory intent and practice is the frequency of serious injuries. A variety of questions might be posed based on any one of these incidents. To illustrate, in 1993, a beltman was fatally injured while cleaning an area around an underground belt drive. The U.S. Mine Safety and Health Administration (MSHA) investigative report (4) notes:

A beltman was fatally injured when he partially removed a guard from the side of a stationary roller and entered the take-up area with the belt in motion. Guarding for the belt and take-up assembly was constructed with four foot wide by eight foot long sheets of expanded metal welded in angle iron frames and bolted onto a main frame. The guarding was then secured to the entire length of the drive and take-up assembly on both sides. Evidence indicated that the victim partially removed the stationary guard in an attempt to gain access to the take-up area. While shoveling loose coal, he became caught in the roller and was fatally injured.

Assuming the guard was "adequate" prior to its removal, what are some questions that might be asked to explore the contributing factors?

1. Was there an appropriate machine guarding policy at the mine?
2. How was the employee trained? Were there any follow-up observations of his performance?
3. Was there a lockout-tagout procedure?
4. Was the hazard recognizable?
5. Was this a safe practice?

Responses to these questions highlight variability. These include perceptions of what constitutes (1) an *appropriate* policy, (2) *quality* training, (3) an *adequate* procedure, (4) a *recognizable* hazard, and (5) a *safe* practice. These perceptions would be expected to vary within and across the inspectorate, work force, and management.

Outside of mining, the importance of researching these questions is magnified. For example, within the agricultural sector, Etherton (5) estimates that 20,000 occupational amputations occur annually. Ninety percent of these serious injuries are traced to machinery and equipment. The magnitude and severity of these injuries amplify the need to pose serious questions. The careful consideration of these questions might lead to a better understanding of the variability between regulatory intent and everyday practice.

### LITIGATION

Another indication of variability is perhaps evident in the number of legal controversies surrounding safe or unsafe guarding practices. In more than a few cases, the final determination of "compliance" with guarding regulations is a product of the judicial system. In one case, involving a piece of mobile equipment, it was determined that failure to properly guard the cooling fan blades and air compressor belts and pulleys located on the front of the engine was a valid violation. The parts in question were located in the center of the engine compartment in



front of the engine. In order for an individual to contact the parts, it would be necessary to reach over the truck frame, which is approximately 76.20 cm high, and extend one's arm a distance of approximately 76.20 to 91.44 cm. The judge ruled that "given the physical accessibility of the engine compartment, the fact that mechanics could check and work on running equipment, and that contact with the cited machine parts could occur, we conclude that a reasonable possibility of contact existed" (6). In litigation, variability is exhibited by the opposing views of those involved in the case.

### VIOLETION AND CITATION DATA

Violation and citation data may also imply large levels of variability within and across the inspectorate, general work force, and management. In 1991, for general industry, OSHA reported over 4,000 violations issued for unsafe machine guarding practices, with an initial dollar penalty of \$6.64 million (7). The direct costs resulting from citations of unsafe machine guarding ranked third, behind

hazard communication and electrical lockout-tagout procedures.

A review of MSHA data indicated that from 1991 through 1993 there were 20,517 significant and substantial violations issued for unsafe guarding practices in the mining industry (8). These numbers may be directly linked to the undefined variability that surrounds safe guarding practices.

How one interprets machine guarding regulations, how one determines if a guard is adequate (or, in compliance with the regulations), how one maintains or modifies a guard, or how one adheres to safe guarding practices can all contribute to large levels of variability.

For the regulators, the violation data explicitly imply variability in compliance profiles. Implicitly, is the issue one of adherence (motivation and skills)? Is it one of how workers and managers interpret the regulations? Or, a combination of both? Knowledge does not guarantee a decision to act, nor does it obligate the appropriate action. What can be learned from studies of traditional mine safety training that could offer insight to these questions?

## TRADITIONAL METHODS FOR MINE SAFETY TRAINING

Safety training is a common method to inform and motivate workers to adhere to safety procedures and requirements. Its widespread acceptance to loss prevention is ingrained within regulations, company policies, and culture of the workplace. Training implies increased competence; competence suggests some means to measure; and measurement implies a connection between the training intervention and goals of the organization. Improved competence, in turn, cannot be defined without some means of evaluation. The concept of training (and performance) evaluation is consequential, as it suggests a means for improvement.

USBM-sponsored studies of mine safety training were described in a series of research reports by Adkins (9), Digman (10), Short, (11), and Cole (12) spanning the period of 1976 to 1986. These evaluative studies of mine safety training, coupled with the general safety training literature, offer insight into methods to understand the limitations of traditional safety training. Combined, these studies suggest a shift to instructional procedures that can better tie investments in training to the performance of the workforce. Performance measures imply a reliable means to evaluate, both within the context of the training and how those skills are transferred to the worksite.

Two of the more recent studies (10, 12) observed a noticeable level of variability in both the conduct and outcomes of classroom health and safety training. This variability was observed during annual refresher training

sessions. Researchers noted several of the reasons for this variability:

1. There was confusion among the trainers and participants concerning the expected outcomes of safety training.

2. There is limited availability of good test designs to assess health and safety knowledge and the application of that knowledge.

3. Miners were more attentive when participation was encouraged or instructors used stories or examples to ground the instruction.

4. The preponderance of concern was more apt to relate to quantity of instruction (i.e., hours of training) as opposed to outcomes (quality).

5. The use of innovative teaching techniques (games or simulations) was fairly common but usually limited to the factual recall of safety information.

6. Trainees appeared most attentive when discussions involved the resolution of a safety problem in a work procedure or emergency protocol.

These studies suggest that traditional mine safety training could benefit by more objective and reliable data. These data would better connect safety training interventions to the performance of the work force. It is within this context that the following training exercise was developed.

## A NEW APPROACH

The "Raggs and Curly" machine guarding exercise is a three-dimensional (3-D) latent image simulation.<sup>4</sup> The idea of combining 3-D slides with latent image simulation was first introduced in 1989 (13-14). The Raggs and Curly exercise embeds teaching with evaluation, makes use of 3-D slides to enhance the fidelity of the simulation, and is administered in small group settings. It is similar in structure and complements the growing set of interactive, latent-image, problem-solving simulations described elsewhere (e.g., 12, 15).

Raggs and Curly is an eight-question, seven-slide exercise that deals with machine guarding hazards and unsafe practices. The Raggs and Curly exercise is set at a surface coal mine. The situation is as follows:

You, Earl E. Raggs, are the chief mechanic at the main mine complex of the AB Coal Company. You have been called to the Jake's Run surface mine. The mine supplies coal directly to rail cars by means of a 48" mobile conveyor. The superintendent explains that during a recent insurance company inspection, some potentially dangerous situations concerning improper guarding practices were noticed. He instructs you to conduct a survey and document the guarding problems you observe around the mobile conveyor. Your recommendations will be part of a planned company wide guarding policy. He assigns Noah "Curly" Hair, who just recently became a mechanic's helper at this operation, to accompany you. The superintendent stresses the fact that Curly is not too familiar with safe guarding practices and asks that you take this opportunity to share your knowledge concerning guarding. You and Curly are to report back to the superintendent with your findings.

Skills developed through this classroom simulation include machine and equipment guarding strategies and procedures; hazard identification; warning and caution sign

<sup>4</sup>The authors are indebted to D. L. Garry, mining industry specialist, and R. A. Dorton, safety and occupational health specialist, both at the USBM's Pittsburgh Research Center, Pittsburgh, PA, for their invaluable assistance in designing this exercise.

usage; safe work habits; safe guarding practices; and decisions involved in the use of factual, regulatory information in their application to specific machinery and equipment.

The exercise follows Raggs and Curly as they evaluate machine guards and discuss safe guarding practices. The efficiency of the training is noted through the opportunities to experience real-life situations and the application of factual knowledge often reserved for on-the-job learning. The classroom training and discussion provides a controlled setting for trainees to experience the consequences of both good and bad decisionmaking. The exercise itself is designed to reinforce good decisions and to correct errors when inappropriate decisions are made.

The exercise seeks to apply and reinforce important characteristics in guard design and construction. These characteristics of guard design are summarized in the widely distributed "MSHA Guide to Equipment Guarding for Metal and Nonmetal Mining" (16). As MSHA notes: "Such guards should:

1. Be considered a permanent part of the equipment or machine.
2. Afford maximum protection.
3. Prevent access to the danger zone.
4. Be convenient—they must not interfere with efficient operation.
5. Be designed for the specific machine, with provisions made for oiling, inspecting, adjusting, and repairing machine parts.
6. Be durable and constructed strongly enough to resist normal wear.
7. Not present a hazard in itself."

The guard might also be constructed to contain those parts that may fail or be propelled to possibly strike employees.

As participants work through the exercise, they begin to discover the difficulties that can exist in the interpretation of regulations, the necessity for safe guarding practices, and common misperceptions about guarding requirements. It is within this context that this exercise approaches training. (See the appendix for problem example.)

The exercise is now being field tested and will be revised as needed. Once completed, the exercise will be sent to the Mine Safety and Health Academy located in Beckly, WV, for distribution to those mining companies requesting machine guarding training exercises.

## SUMMARY AND CONCLUSIONS

Variability within the applied interpretations of rules, regulations, and actual work practices may be a major contributing factor in machine guarding injuries, violations, and litigation. The experimental training simulation discussed in this paper is an attempt to better define and understand differences in the interpretation and application of machine guarding regulations. The use of the 3-D slides within a realistic problem setting can improve the

fidelity of safety training, thus aiding in the transfer of safety skills. The benefits of this and similar exercises could be a further reduction in the number of injuries related to improper guarding practices, less reliance on the judicial system to resolve a variety of interpretations of machine guarding regulations, and a reduced level of violations.

## REFERENCES

1. Smith, C. O. Problems in Machine Guarding. Paper in American Society of Mechanical Engineers Annual Conference (Boston, MA, Dec. 13-18, 1987). ASME, New York, 1987.
2. McElroy, F. E. Accident Prevention Manual for Industrial Operations. Natl. Saf. Council, Chicago, IL, 8th ed., 1980, pp. 285-313.
3. National Safety Council (Chicago, IL). Accident Prevention Manual for Industrial Operations. 7th ed., 1980, 795 pp.
4. Shortridge, D. C. Accident Investigation Report. U.S. Mine Saf. and Health Admin., Sept. 1993.
5. Etherton, J. R., and M. L. Myers. Machine Safety Research at NIOSH and Future Directions. *Int. J. Ind. Ergon.*, v. 6, No. 2, 1989, pp. 163-174.
6. Federal Mine Safety and Health Review Commission. Docket PENN 81171, Sept. 1984, pp. 2094-2098.
7. Wienstock, M. P. Avoiding the Top Ten. *Occup. Hazards*, Sept. 1992, pp. 36-39.
8. U.S. Mine Safety and Health Administration. R-63, Violation Counts by Standard and Type of Assessment. Jan. 26, 1994.
9. Adkins, J., R. Akeley, P. Chase, L. Marrus, W. Prince, R. Redick, C. Rogne, J. Saalberg, and L. Szempruch. Review and Evaluation of Current Training Programs Found in Various Mining Environments; Volume I, Summary (contract SO144010, Bendix Corp.). BuMines OFR 110(1)-76, 1976, 67 pp.; NTIS PB 259 410.
10. Digman, R. M., and J. T. Grasso. An Observational Study of Classroom Health and Safety Training in Coal Mining (contract J0188069, WV Univ.) BuMines OFR 99-83, 1982, 65 pp.; NTIS PB 83-210518.
11. Short, J., J. Harris, J. Waldo, and S. Barber. A Study To Determine the Manpower and Training Needs of the Coal Mining Industry (contract J0395038, John Short & Assoc., Inc.). BuMines OFR 14-80, 1979, 145 pp.; NTIS PB 80-164742.
12. Cole, H. P., L. G. Mallett, J. V. Haley, P. K. Berger, W. E. Lacey, R. D. Wasielewski, G. T. Lineberry, and A. M. Wala. Research and Evaluation Methods for Measuring Nonroutine Mine Health and Safety Skills (contract H0348040, Univ. KY). Volume I. BuMines OFR 18(1)-89, 1988, 229 pp.; PB 89-196646; Volume II: Appendices. BuMines OFR 18(2)-89, 1988, 348 pp.; PB 89-196653.
13. Barrett, E. A. Innovative Idea for Teaching Hazard Recognition Skills to Miners. *BuMines Technol. News* 409, Oct. 1992, 2 pp.
14. Barrett, E. A., W. J. Wiehagen, and C. Vaught. Roof and Rib Hazard Recognition Training Using 3-D Slides. Paper in Mine Safety Education and Training Seminar. BuMines IC 9185, 1988, pp. 23-30.
15. Cole, H. P., G. T. Lineberry, A. M. Wala, J. V. Haley, P. K. Berger, and R. D. Wasielewski. Simulation Exercises for Training Miners and Mining Engineers. *Min. Eng.*, v. 45, No. 11, Nov. 1993, pp. 1397-1401.
16. U.S. Mine Safety and Health Administration. MSHA Guide to Equipment Guarding for Metal and Nonmetal Mining. Rev. 1992, reprinted 1993, 32 pp.

## APPENDIX

The appendix consists of a problem workbook and a master answer sheet. These items represent a completed exercise.

**Raggs and Curly Guarding Exercise**

**Problem Booklet**

Mining Systems and Human Engineering  
U.S. Bureau of Mines  
Pittsburgh, PA

July 1994

**Instructions**

Read the problem situation described on the next page. Then answer each of the eight questions. Do them one at a time. Some questions will ask you to look at one or more three-dimensional slides. Look at the appropriate slide or slides, then continue on with the exercise. Don't jump ahead, but look only at the questions and slides to which you are directed. However, you may look back to earlier questions and answers at any time. Follow the directions for each question.

After you have selected a choice to a question, look up its number on the answer sheet. Select your answer(s) to each question by slowly and gently rubbing the special pen between the brackets on the answer sheet. A hidden message will appear and tell you if you are right. When you have finished, you will learn how to score your performance.

**The Situation**

You, Earl E. Raggs, are the chief mechanic at the main mine complex of the AB Coal Co. You have been called to the Jake's Run Surface Mine. The mine supplies coal directly to rail cars by means of a 121.92-cm (48-in) mobile conveyor. The superintendent explains that during a recent insurance company inspection, some potentially dangerous situations concerning improper guarding practices were noticed. He instructs you to conduct a survey and document some of the guarding problems you observe around the mobile conveyor and make recommendations for correcting these problems. Your recommendations will be part of a planned company-wide guarding policy. He assigns Noah "Curly" Hair, who was just recently reassigned as a mechanic's helper at this operation, to accompany you. The superintendent stresses the fact that Curly is not too familiar with safe guarding practices and asks that you take this opportunity to share your knowledge concerning guarding. You and Curly are to report back to the superintendent with your findings. Turn to Question A.

*Raggs & Curly Guarding Exercise***Question A**

You and Curly take a camera and notebook and begin to document the status of the guards located at the mobile conveyor area. Look at slide 1. You are looking for unsafe guarding practices and related problems. What should you point out to Curly? (Select as MANY as you think are correct.)

1. A dirty warning sign.
2. A missing guard.
3. Altered guard.
4. Coal spillage.
5. A missing guard around the electrical box.

When you have made your selection(s), do the next question.



**Question B**

Continuing your survey, you and Curly go to the rear of the bin. Look at slide 2. What hazards would you note and point out to Curly at this location? (Select as MANY as you think are correct.)

6. The salamander is located too close to the fuel depot.
7. There are holes in the guards.
8. The guard is not extended far enough to enclose all pinch points.
9. Warning signs are inadequate.
10. Coal has built up here.
11. Guard screens are not aligned.

When you have made your selection(s), do the next question.

*Raggs & Curly Guarding Exercise***Question C**

The next place you stop is a conveyor dump point. Look at slide 3. Other than repairing the holes in the guards and cleaning up obvious spillage, what corrective measures should you recommend to the superintendent for this area? (Select as MANY as you think are correct.)

12. Replace the missing triangular guard on the near side.
13. Display warning signs.
14. Investigate the cause of the large coal chunks underneath the equipment.

When you have made your selection(s), do the next question.

**Question D**

You walk around the dump point to look at the other side. This is what you see. Look at slide 4. What corrective measures should you and Curly recommend to the superintendent for this area? (Select as MANY as you think are correct.)

15. Display warning signs.
16. Repair the holes in the guard.
17. Investigate the cause of the large coal chunks underneath the equipment.

When you have made your selection(s), do the next question.

**Question E**

You and Curly travel to the mobile conveyor. Look at slide 5. You ask Curly to assess this piece of equipment. What positive guarding practices would you expect Curly to note? (Select as MANY as you think are correct.)

18. Effective use of multiple guarding materials.
19. Extended grease fittings.
20. Handrail and toe boards.
21. Walkway is clear of all slip and trip hazards.
22. Guarding for machinery parts that are out of reach.

When you have made your selection(s), do the next question.

**Question F**

Curly mentions to you that he saw another example of guarding on a piece of mobile equipment. Look at slide 6. This is a refurbished piece of equipment that arrived from the factory not too long ago. After new tires are put on it, what guarding changes, if any, do you think should be made before the equipment is put into use? (Select as MANY as you think are correct.)

23. No changes should be made because this is the way it came from the factory.
24. Extend the height of the guard around the engine compartment.
25. Paint the engine compartment guards a different color than the equipment.
26. Extend the guarding down to cover the top of the tire.
27. Install warning signs and reflective materials on the step.

When you have made your selection(s), do the next question.

**Question G**

You decide to conclude this initial phase of the survey by asking Curly to survey his work area near where the compressed gas is stored. Look at slide 7. You see quite a few potential hazards at this site and decide to have Curly point them out to you. What should Curly point out as potential hazards? (Select as MANY as you think are correct.)

28. The handrail is lying off to the side and not attached to the steps.
29. Combustible materials are stored too close to the compressed gas.
30. There are no signs indicating compressed gas storage.
31. Batteries are not stored properly and are placed too near the compressed gas.
32. Compressed gases are not secured in place.
33. Compressed gases should be stored in metal sheds.
34. Housekeeping is poor in this area.
35. There are no fire extinguishers here.

When you have made your selection(s), do the next question.

**Question H**

You meet with the superintendent to brief him on your findings. Besides the condition of the guards themselves, what are some other safety practices that you might recommend to support safe work procedures around moving parts? (Select as MANY as you think are correct.)

36. Warning signs placed in close proximity to moving parts.
37. Materials used for guarding should be substantial and heavy.
38. Written procedures such as SOP's and JSA's that address specific tasks.
39. A maintenance and inspection program specifically aimed at guarding.
40. Removal of a guard only after a piece of equipment has been deenergized or locked and tagged out.
41. Guards should be designed and modified to protect maintenance personnel as well as to make their job easier.

**End of Problem**

**Scoring your performance**

1. Count the total number of responses you colored in that were marked "correct." Write this number in the first blank on the answer sheet.
2. Count the total number of incorrect responses you colored in. Subtract this number from 9. Write the difference in the second blank on the answer sheet.
3. The best score is 41. The worst score is 0.

**Master Answer Sheet for the Raggs & Curly Guarding Exercise**

Use this answer sheet to mark your selections. Rub the special pen gently and smoothly between the brackets. Don't scrub the pen since the message may blur. Be sure to color in the entire message once you have made a selection. Otherwise, you may not get the information you need. The last part of the message will tell you what to do next.

**Question A** (Select as MANY as you think are correct.)

- 1. [Correct. It is a good idea to clean the illegible sign. A comprehensive guarding policy should include periodic cleaning of warning and caution signs. ]
- 2. [Correct. A missing guard exposes a hazard. ]
- 3. [In many circumstances it may be necessary to alter existing guards. The addition of straps to this guard strengthen and protect it. ]
- 4. [Correct. Coal buildup can be a fire and tripping hazard. The amount of coal may indicate that additional maintenance is necessary here. ]
- 5. [The electrical box does not require additional guarding in this situation. ]

**Question B** (Select as MANY as you think are correct.)

- 6. [The distance between the salamander and the fuel depot is adequate and poses no hazard. ]
- 7. [Correct. Holes in guards present a hazard because they make it possible for persons to come into contact with moving parts. ]
- 8. [Correct. Even if the guard was in good condition, the rollers would not be completely enclosed by the guard. Contact with moving parts is not prevented here. ]
- 9. [Correct. Warning and/or caution signs are a good safety practice. ]
- 10. [Correct. Coal buildup is a potential fire and tripping hazard. The amount of coal seen here may indicate that equipment modifications may be necessary to prevent continued spillage. ]
- 11. [Correct. Space left between the frames of guards allows openings where fingers could contact moving parts. ]



**Question C** (Select as MANY as you think are correct.)

12. [Correct. If you look closely, you can see a triangular guard on the opposite ]  
 [side of the structure. It may be a possible violation if a similar guard is ]  
 [not in place on this side of the structure. ]
13. [Correct. It is a good policy to include caution and warning signs as ]  
 [part of the guarding program. ]
14. [Correct. This problem needs to be addressed. Either the area should ]  
 [be guarded so that the large pieces can be confined or the source of ]  
 [the problem should be remedied. ]

**Question D** (Select as MANY as you think are correct.)

15. [Correct. It is a good policy to include caution and warning signs as part of ]  
 [the guarding program. ]
16. [Correct. Holes in guards present a hazard because they make it possible for ]  
 [persons to come into contact with moving parts. ]
17. [Correct. This problem needs to be addressed. ]

**Question E** (Select as MANY as you think are correct.)

18. [Correct. Materials used include screen, belting, and manufacturer equipped ]  
 [guards. ]
19. [Correct. Extended grease fittings and cups allow for easy greasing of ]  
 [moving parts and are required. ]
20. [Correct. Sometimes we forget that guarding includes handrails to ]  
 [guard against the employee falling from an elevated position. ]
21. [Correct. There is no problem here. ]
22. [Correct. Even though they are out of reach, moving parts may break ]  
 [and pieces may fly out and hit someone if not guarded. ]

*Raggs & Curly Guarding Exercise*

**Question F** (Select as MANY as you think are correct.)

23. [This is not necessarily true. Manufacturer's specifications do not always meet ]  
[company, State, and Federal regulatory agency guarding specifications. ]
24. [Correct. The existing guard does not adequately stop access to ]  
[potential hazards. ]
25. [Correct. This is recommended to make guards more obvious. ]
26. [This is not practical. If guards were there they could restrict movement ]  
[of the wheels and could be a hazard. ]
27. [Correct. Warning signs are good guarding practice. The use of reflective ]  
[materials along the catwalk of the machine and around the other guards can ]  
[draw attention to potentially hazardous areas, such as the step as a tripping ]  
[hazard. ]

**Question G** (Select as MANY as you think are correct.)

28. [Correct. Handrails provide a means of support and guard against  
[accidental slips and falls. ] ]
29. [Correct. Combustible materials may be an ignition source and a fire  
[could easily develop. ] ]
30. [This is not required. The only sign required is a "NO SMOKING-NO  
[OPEN FLAMES" sign. ] ]
31. [Correct. Batteries may be a source of hydrogen gas, which is highly  
[explosive. Batteries should be kept in a secure location to guard  
[against chemical burns. ] ]
32. [The safety chains shown are adequate and the door is locked. ] ]
33. [That is not a problem here. It is not recommended that compressed  
[gas be stored in metal sheds because of the potential heat buildup. ] ]
34. [Correct. Side of stairs is broken and steps are not anchored solidly to  
[the shed. Accumulations of unmarked drums and debris create a  
[potential fire hazard. ] ]
35. [Correct. Fire extinguishers are required because it is a wooden  
[structure that presents a fire hazard. ] ]

*Rags & Curly Guarding Exercise*

**Question H** (Select as MANY as you think are correct.)

36. [Correct. Warning signs alert personnel to potential hazards associated  
[with moving parts. ] ]
37. [This doesn't make a good guard. Additional hazards may be  
[introduced when trying to remove a heavy guard. ] ]
38. [Correct. These procedures clarify safe practices to be followed  
[including guarding issues. ] ]
39. [Correct. Through a preventive maintenance schedule and regular  
[inspection, guarding problems can be documented and corrected. ] ]
40. [Correct. This is always a good practice. In addition, thought  
[should be given to other forces, such as belt tension and pressurized  
[liquids and gases. ] ]
41. [Correct. One example is extended grease fittings and cups, which  
[eliminate the need to work close to moving parts when lubricating. ] ]

**End of Problem**

**Scoring your performance**

1. Count the total number of responses you colored in that were marked "correct." Write this number in the first blank on the answer sheet.
2. Count the total number of incorrect responses you colored in. Subtract this number from 9. Write the difference in the second blank on the answer sheet.
3. The best score is 41. The worst score is 0.

# ERGONOMIC AND STATISTICAL ASSESSMENT OF SAFETY IN DEEP-CUT MINING

By Lisa J. Steiner,<sup>1</sup> Fred C. Turin,<sup>1</sup> and Christopher A. Hamrick<sup>1</sup>

---

## ABSTRACT

This U.S. Bureau of Mines paper examines the occupational safety concerns associated with deep-cut mining. Mining deeper cuts may have some unknown effects on how miners position themselves for visibility, the types of accidents that can occur, and the new interactions between the equipment and the continuous miner operator. This preliminary report utilizes data from the U.S. Mine Safety and Health Administration accident database, interviews with mine workers and mine operators, and conversations with State, local, and union representatives. A statistical analysis was performed to compare injuries and fatalities

that occurred in mines with deep-cut approval to mines that did not have deep-cut approval. The data were categorized by mine size. A series of interviews with over 50 mine workers in 5 States was also conducted. A preliminary task analysis study revealed some concern in the following areas: the bolting cycle, continuous miner operator positioning and visibility, mine conditions and depth of cut, cable handling, and remote-control unit design. Methods that will be used to study these tasks are discussed.

## INTRODUCTION

Like many other industries, mining companies implement new technologies as they are developed to increase productivity and/or increase safety. These technologies require research to explore what unintended effects these new methods, machinery, and interfaces will have on mine workers. Deep-cut mining refers to mining a cut of coal with a continuous miner deeper than the standard 6.1-m (20-ft) cut. A standard cut may be mined with the miner operator using controls on the deck of a continuous miner or by using a remote-control unit for a continuous mining machine. In either case, the miner operator is protected under a roof that has been bolted. With the development of the remote control and better dust control and ventilation methods, miner operators are able to mine more than 6.1 m (20 ft) while still remaining under a supported roof area (fig. 1). These deeper cuts allow the miner operator

to mine coal for a longer period of time without moving the machinery as often, which in turn is expected to increase productivity and safety. To be permitted to perform deep cuts, a mine must apply for U.S. Mine Safety and Health Administration (MSHA) approval. MSHA has various conditions and equipment updates that must be met before approval is given. Currently, MSHA information states that approximately 22.3% of U.S. underground coal mines have deep-cut approvals.

Bauer, Pappas, and Listak (*1*)<sup>2</sup> examined fatal coal mining accident data from 1988 through 1990. They reported that the rate of fatal roof falls is 2.5 times higher in mines with deep-cut approval, considerably larger roof falls occur when deep-cut mining is practiced, and geology-influenced roof fall fatalities occur about equally in deep-cut and nondeep-cut mining. However, they reported that

---

<sup>1</sup>Industrial engineer, Pittsburgh Research Center, U.S. Bureau of Mines, Pittsburgh, PA.

<sup>2</sup>Italic numbers in parentheses refer to items in the list of references at the end of this paper.

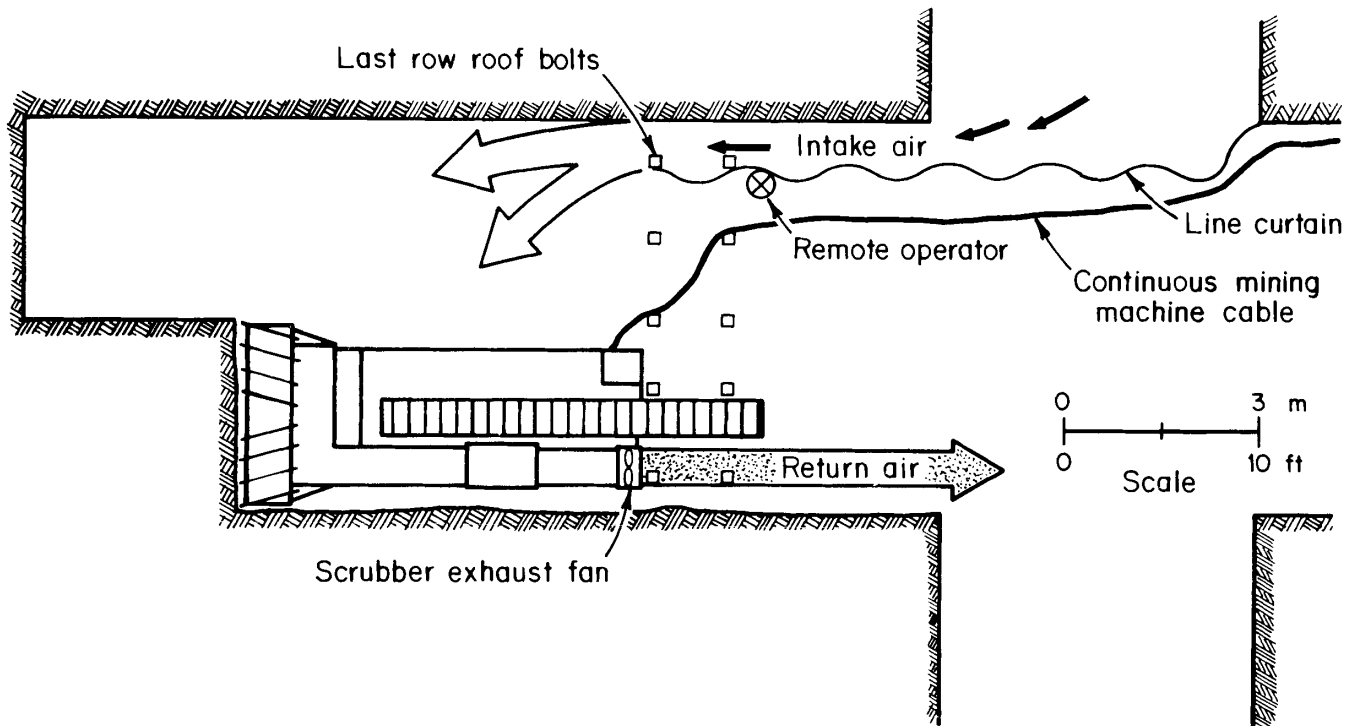

Figure 1.—Diagram of deep-cut mining method.

nearly half of the fatalities for deep-cut mining were the result of illegal deep cutting. These were classified as illegal because the mines either exceeded the approved length of cut or did not have MSHA deep-cut approval. The rate of legal deep-cut fatalities was found to be at a rate slightly below that of nondeep-cut fatalities.

Davis (4) conducted a detailed analysis of roof fall fatalities in 1990. It was found that 7 of 20 (approximately 31%) fatalities occurred in a deep cut. However, only one fatality occurred in a deep cut made in compliance with an approved plan. The remaining six fatalities occurred while illegal deep cuts were being taken.

Bauer, Steiner, and Hamrick (2) examined 1990 and 1991 MSHA accident data to compare reported accidents in deep-cut and nondeep-cut mines by mine size. The data indicated that the reported accident rate and the rate of accidents at the face were higher for all mines taking deep cuts in all size categories, with the exception of those mines with a 150- to 250-employee range. Overall, deep-cut mines had a 23% higher reported accident rate at the face and a 12% higher rate of accidents. Reported accidents included those which did not result in injury. Fatality rates were found to be lower in deep-cut mines, with the exception of mines in the 50- to 150-employee range. The overall fatality rate was 37% lower for deep-cut mines.

Many studies have explored the overall productivity effects of deep-cut mining. It is believed that taking deep cuts will improve productivity through decreased tramping time since the machine will stay longer in each working face. In a U.S. Bureau of Mines (USBM) study (11) of 25 mines to assess the reasons for high productivity, 2 mine operators said that their productivity per section increased by about 25% by using deep cuts. The 4 mines that had depths of cut of 9.14 m (30 ft) or more had an average section production of 1,067 t (1,050 st) per shift while the 21 mines with a depth of cut of less than 9.14 m (30 ft) averaged 892 t (878 st) per shift. However, in a mine with 1,476 t (1,452 st) per shift, it was found that deep-cut mining did not improve overall productivity. This might mean that as maximum productivity for a given mining system is approached, small technological changes become less important and major technological innovation, such as longwall mining, is needed for major production increases. In other words, mines that have a higher production rate may not see as much of a production rate change by implementing deep-cut technology as would a mine with a lower production rate. In mines with lower productivity rates, however, implementation of technological change, such as deep-cut mining, may result in a substantial improvement.

Deep-cut mining has not only shown improvements at the productivity level, but has also been attributed to improving safety by removing the continuous miner operator from inherent dangers at the mine face and decreasing the respirable dust levels through the required use of scrubber and fan-spray systems. By relocating the continuous miner operator from the face return air position to the face intake air position, a 94% reduction in respirable dust was evidenced (6).

Though deep-cut mining has introduced new safety features, it may have introduced new hazards. Vertical visibility may be limited when cutting the deeper cuts, which may cause some extraction of the roof and floor (3). Another study, performed by the USBM, revealed that continuous miner operators were standing in positions that were not recommended by their standard operating procedures because of the inability to see from these recommended positions (8). The study concluded that the positions used were not in accordance with the safe operating procedures of the mine and that there was a problem with determining a safe position with adequate visibility. The results of the study are magnified as the variance is granted for deeper cuts. As the length of cut increases, visibility, staying on the sight line, and watching the roof

changes become more difficult. The continuous miner operator is removed from the machine through the use of the remote control and has to rely heavily on sound and sight senses instead of vibration for condition and position cues. The further the miner operator is away from the face, the potential for misreading cues increases and, therefore, the potential for mistakes and accidents increases.

Though deep-cut mining has been embraced by the mining industry as a way to avoid the obvious safety and efficiency drawbacks of the machine-mounted compartment, research addressing the new issues is still relatively new and scarce. There is a lack of information regarding training for miners who will be or are using deep cuts. Because of varying mine conditions, not all mines will have the same problems and their experiences with deep-cut mining will vary. The USBM is taking a systematic look at the new technology to help identify problems associated with deep-cut mining and to address problems associated with standard-cut mining. A first step in identifying problems is to take a look at current available accident data. In this paper, the USBM examines the occupational safety concerns associated with deep-cut mining. This work was done in support of the USBM's goal to enhance the safety of the Nation's underground miners.

## STATISTICAL ANALYSIS

### Introduction

The most objective measures of mine safety are the frequency and severity rates of mining accidents. An important element of the research to assess the safety of deep-cut mining operations has been an evaluation of mine accident data collected by MSHA. In particular, accident data of mines that had MSHA approval to take deep cuts have been compared with accident data of mines that did not have approval to take deep cuts.

Title 30, part 50 of the U.S. Code of Federal Regulations (14) requires mine operators to notify MSHA immediately of mine accidents and to investigate accidents. Mine operators must file reports with MSHA pertaining to accidents, occupational injuries, and occupational illnesses using form 7000-1. Mine operators must also report employment and production data using form 7000-2. MSHA generates yearly data files containing employment and production data, as well as reported accident, injury, and illness information. In recent years, the MSHA data files have included estimated accident costs, as determined by the USBM's accident cost indicator model (ACIM). ACIM considers the type of accident and other factors, such as regional medical treatment rates to estimate costs to the public, industry, and family (5).

### Method

Mines that had approval to take deep cuts were compared with mines that did not have approval using MSHA employment, production, and accident data. The data were classified and selected as follows: First, mines that had obtained approval to take deep cuts for 1990 and 1991 were identified in the data files. Second, mines that used longwall technology in these 2 years were identified in the data files. The list of longwall mines was obtained from Merritt (9-10). Third, data for mines without longwall operations, with underground coal production greater than zero tons, and with at least 16,000 underground employee hours were selected [16,000 equates to approximately 8 underground workers (a minimal face crew), working for a year]. Fourth, accident records for underground workers who were fatally injured or had lost-time injuries were selected.

### Results

Table 1 presents the number of mines, underground hours worked, and productivity data for mines with and without approval to take deep cuts. Data are presented for four mine size categories: average number of

employees less than 50, average number of employees between 50 and 150, average number of employees between 150 and 250, and average number of employees greater than 250. Overall results are presented as well.

Table 2 displays fatality rates and nonfatal lost-time injury rates for mines with and without deep-cut approvals. Rates are normalized to 200,000 underground hours worked. In addition, the average number of days lost per nonfatal lost-time injury and average estimated cost per nonfatal lost-time injury are displayed. Results are categorized by mine size in the same manner as in table 1.

Additional incidence rates were calculated for small (average number of employees less than 50) mines with and without deep-cut approvals. These rates were broken down according to "accident-injury-illness" type, mine worker activity, and job title. These results are displayed graphically in figures 2 through 4, respectively.

### Limitations

It would be desirable to compare the characteristics of accidents that occur when a deep cut is taken to those that occur when a cut of 6.1 m (20 ft) or less is taken. Unfortunately, MSHA data files do not identify whether a mine was taking a deep cut at the time of an accident. The only information available is the identity of mines with MSHA

approval to take deep cuts for the years 1990 and 1991. For this reason, the analyses compare mines with and without deep-cut approvals for 1990 and 1991. It is not known what percentage of deep-cut mining is done at mines with deep-cut approval. It is also known that some deep-cut mining is done at mines without deep-cut approval (1, 4). However, it is assumed that deep-cut mining is more prevalent at mines with deep-cut approval.

Data that are reported to MSHA on the 7000-1 and 7000-2 forms are not always complete. The most accurately reported accidents are those that resulted in a fatality. It is also more likely that accidents that result in lost work time will be reported accurately. This analysis only examines accidents that resulted in a fatality or a lost-time injury.

Longwall mining and mine size are two factors that greatly influence the data, and each were addressed in this analysis. However, other factors that influence safety in underground mining that were not addressed include mining conditions, seam height, geology, type of ventilation system used, makeup of the work force, and management structure. Because of the limitations discussed, definitive conclusions about the comparisons that are presented are difficult to make and the interpretation of many of the results will be left to the reader.

**Table 1.—Summary of 1990 and 1991 employment and production data for underground coal mines without longwall operations, categorized by mine size and deep-cut approval status**

| Mine size (average number of employees) | Number of mines (sum of each year's total) |             | Work time, 10 <sup>3</sup> h underground |             | Coal productivity, t/h underground |             |
|---|--|-------------|--|-------------|------------------------------------|-------------|
|   | Deep-cut approval                          | No approval | Deep-cut approval                        | No approval | Deep-cut approval                  | No approval |
| Less than or equal to 50 . . .          | 162  | 1,298       | 9,657                                    | 51,212      | 3.80                               | 3.21        |
| 50 to 150 . . . . .                     | 130  | 156         | 20,309                                   | 22,041      | 3.46                               | 3.04        |
| 150 to 250 . . . . .                    | 50   | 22          | 17,796                                   | 6,995       | 2.87                               | 3.09        |
| More than 250 . . . . .                 | 32   | 13          | 22,699                                   | 6,710       | 2.76                               | 3.09        |
| Overall . . . . .                       | 374  | 1,553       | 70,461                                   | 86,958      | 3.13                               | 3.15        |

**Table 2.—Summary of 1990 and 1991 fatal and nonfatal lost-time injury rates, average days lost, and average total cost for underground coal mines without longwall operations, categorized by mine size and deep-cut approval status**

| Mine size (average number of employees) | Fatal injuries per 200,000 h underground |             | Nonfatal lost-time injuries per 200,000 h underground |             | Average days lost per nonfatal lost-time injury |             | Average total cost per nonfatal lost-time injury, \$ |             |
|---|--|-------------|---|-------------|---|-------------|--|-------------|
|   | Deep-cut approval                        | No approval | Deep-cut approval                                     | No approval | Deep-cut approval                               | No approval | Deep-cut approval                                    | No approval |
|   |  |             |   |             |   |             |  |             |
| Less than or equal to 50 . . .          | 0.12                                     | 0.13        | 12.28   | 11.76       | 42  | 46          | 10,719   | 12,282      |
| 50 to 150 . . . . .                     | 0.06                                     | 0.05        | 13.32   | 12.61       | 41  | 42          | 10,355   | 10,737      |
| 150 to 250 . . . . .                    | 0.04                                     | 0.06        | 15.01   | 15.73       | 45  | 50          | 9,826  | 9,037       |
| More than 250 . . . . .                 | 0.00                                     | 0.06        | 15.08   | 14.04       | 42  | 36          | 10,208   | 10,559      |
| Overall . . . . .                       | 0.05                                     | 0.10        | 14.17   | 12.47       | 43  | 44          | 10,206   | 11,407      |



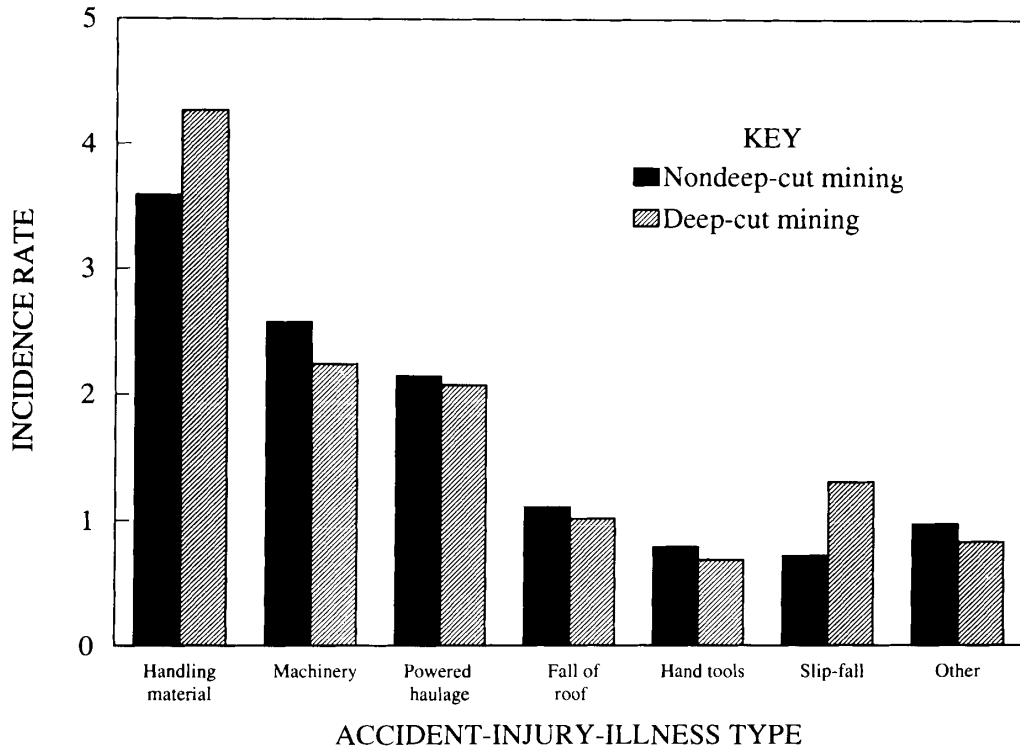

**Figure 2.—Incidence rates (serious accidents per 200,000 underground hours worked) by accident-injury-illness type for small mines (average number of employees less than 50).**

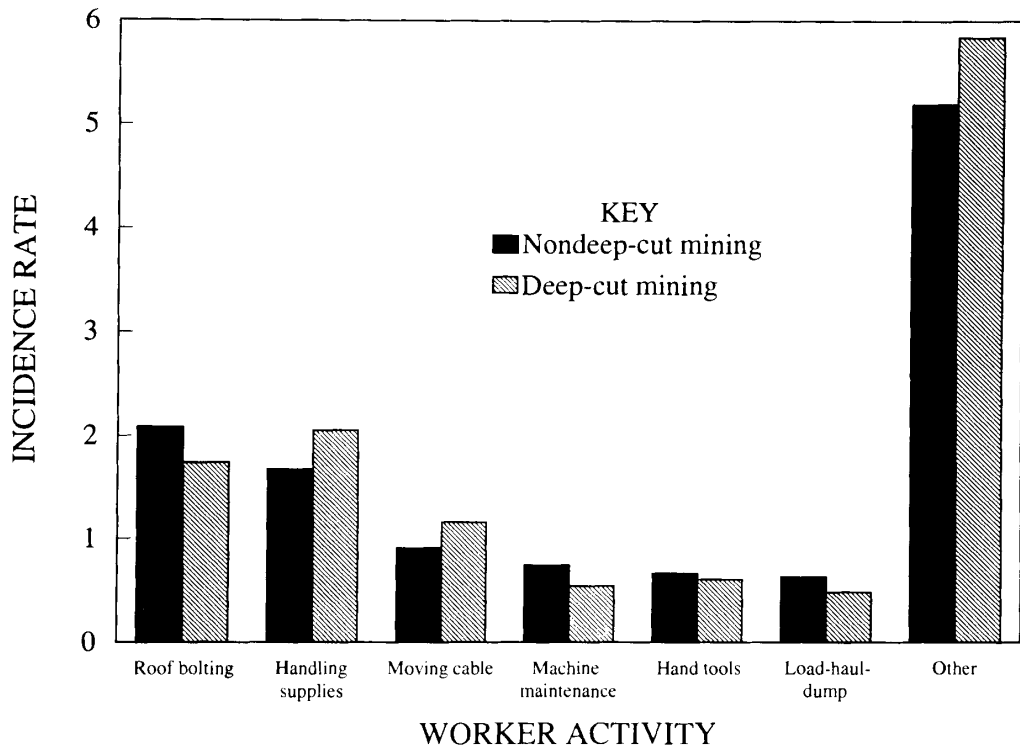

**Figure 3.—Incidence rates (serious accidents per 200,000 underground hours worked) by mine worker activity for small mines (average number of employees less than 50).**

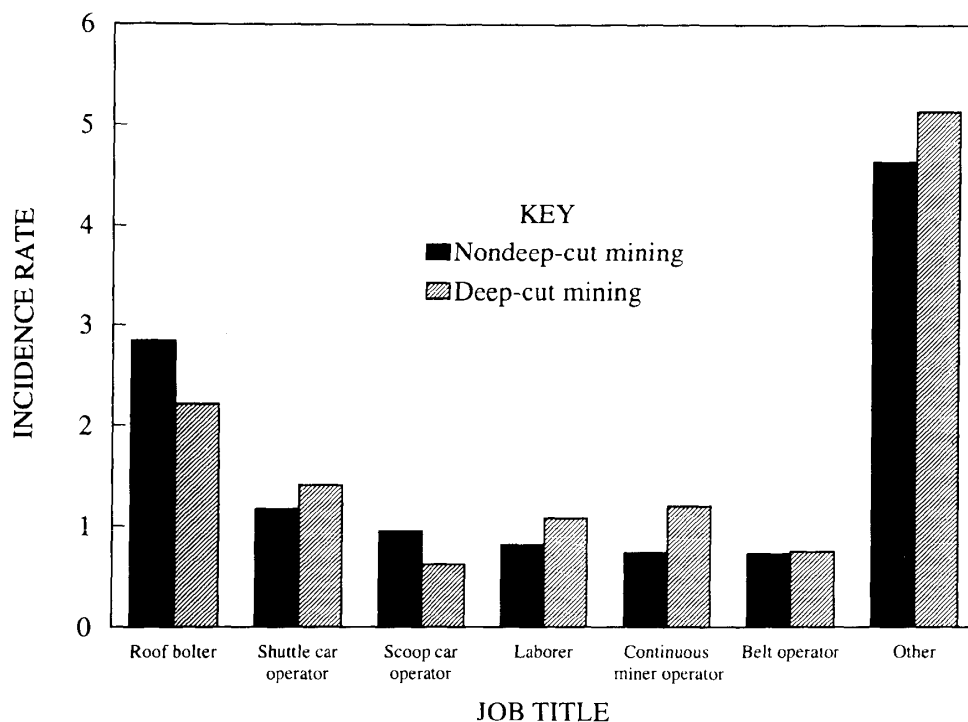

Figure 4.—Incidence rates (serious accidents per 200,000 underground hours worked) by job title for small mines (average number of employees less than 50).

### Discussion

The calculations from data in table 1 indicate that deep-cut mines report more than three times the number of employee hours per mine than mines without deep-cut approval. This fact highlights the need to normalize accidents to exposure hours; any analysis that fails to do so may provide misleading information.

In smaller mines (less than 150 employees), those with deep-cut approval had a higher productivity rate than those without approval. In the larger mines, however, the converse is true. Perhaps this indicates that as mine size increases, the impact on total productivity of taking deep cuts is lessened and other factors that impact on productivity play a more prominent role. When the productivity for all mine sizes are compared, mines with and without deep-cut approval had nearly the same rates.

Table 2 indicates that the overall fatality rate of mines with deep-cut approval was about half that of mines without deep-cut approval (0.05 versus 0.10). However, fatality rates within each mine size category, with the exception of mines with average number of employees greater than 250, were very similar. Fatality rates were higher in the smaller mine categories than in larger mine categories. This indicates that mine size had more impact on fatality rates than deep-cut approval status.

The opposite effect is seen when comparing the non-fatal lost-time injury rates. Mines with deep-cut approval have a slightly higher accident rate than those without

approval (14.17 versus 12.47). It appears that mine size played a significant role in this difference as well. Larger mines reported lost-time injuries at a higher rate than smaller mines.

Two measures of accident severity are days lost and cost per accident. Average number of days lost is approximately the same for mines with and without deep-cut approval. Mine size does not seem to have a significant impact on average days lost. The estimated average cost per nonfatal lost-time injury is slightly higher in mines without deep-cut approval than in those that do have approval (\$11,407 versus \$10,206). Mine size does appear to have some impact on the average cost data. In particular, mines with fewer than 50 employees appear to have the highest average cost per injury.

According to figure 2, "handling materials" was the largest single category of accidents in small mines, accounting for more than 30% of all accidents, and deep-cut mines had an almost 20% higher rate of material handling accidents than nondeep-cut mines. One possible explanation for this statistic is that as deeper cuts are taken, the trailing length of cable of continuous mining machines is longer and, therefore, the lengths of cable to be handled are longer. The longer cable is more difficult to move and is more likely to result in an injury. This explanation is also supported by figure 3, which shows that moving cable is associated with a 26% higher incidence rate in deep-cut mines than in nondeep-cut mines. The accident rate due to handling supplies also is higher in deep-cut mines by

about 22% than in nondeep-cut mines (fig. 3). Slip-fall accidents have a substantially higher rate in deep-cut mines by about 82% than in nondeep-cut mines; however, these accidents only account for about 7% of all accidents in small mines.

One finding of note is that the activity of roof bolting has a lower reported accident rate in deep-cut mines than in nondeep-cut mines (fig. 3). Furthermore, the incidence rate for roof bolters is lower in deep-cut mines by about 22% than in nondeep-cut mines (fig. 4). This finding is interesting because roof bolting is often thought of as one of

the most dangerous tasks in mining. Special concerns have been associated with this task in deep cuts. These discrepancies about the bolting task indicate that this area warrants further investigation through task analysis.

It appears from figure 4 that the job titles of "shuttle car operator" and "continuous miner operator" have higher accident rates in deep-cut mines by 20% and 63%, respectively, than in nondeep-cut mines. The duties performed by these job classifications also should be examined through task analysis so the reasons for these increased rates can be determined and countermeasures suggested.

## UNDERGROUND MINE INTERVIEWS

A questionnaire was used to determine what aspects of deep-cut mining are considered the most critical to the mining industry. To date, over 50 mine workers, including mine operators and supervisors, have been questioned at various mines with deep-cut approvals throughout Pennsylvania, Kentucky, Maryland, and Ohio. The questionnaire addresses various aspects of the worker's experience, mine conditions, and the mine worker's view of safety of deep cuts. Topics included in the questionnaire are miner experience, deep-cut methods and procedures, roof control, accidents and injuries, manual materials handling, control layout and design of equipment, visibility, ventilation, continuous miner operator protection, breaker tripping, maintenance, and general safety questions. The USBM's goal is to cover as many areas as possible to identify any problems particular to deep-cut mining.

In general, the results reflect a positive attitude from the miners and the mine operators toward deeper cuts. Seventy-four percent of the large mine (more than 100 employees) workers and 95% of the small mine (less than 100 employees) workers said that deep-cut mining improved or maintained their productivity levels. The miners believe deep-cut mining is safer because they move the equipment less, thus decreasing the probability of moving accidents. Twenty-two percent of continuous miner operators interviewed felt there was increased safety with remote control in general. They commented that they were more mobile and therefore able to get out of the way of the continuous miner quicker and more safely than when on the deck of the continuous miner. They also felt they were exposed to less noise and dust. Nearly one-half of miner operators thought it would be worthwhile to examine the design of the remote-control unit because of its weight and bulkiness.

Several concerns with deep cuts were raised. Sixty-seven percent of continuous miner operators interviewed said that there were visibility problems and 29% said that it was at least sometimes difficult to stay on the sight line in the deep cuts. Several of these continuous miner

operators stated that a 12.2-m (40-ft) cut is the maximum safe cut because visibility problems begin to occur after that point. Scrubber systems are necessary at any length to help improve visibility. As the roof and rib conditions worsen, miners expressed more concern, especially when taking deep cuts and with any length of cut for that matter. Also, the miner operator's position when operating the continuous miner has become an important safety concern in deep cuts, as voiced by many of the interviewees.

There were varying opinions among the roof bolters of the increased danger of bolting deep cuts. It was difficult for some bolters to keep up with the mining cycle in deep cuts because the extent of roof to be bolted is larger than the standard cut. The cutting task and the bolting task have become more efficient because of decreases in tramming time, but it is not known whether the tramming time has decreased proportionately for both. The bolting task time is heavily dependent on several variables. If there are poor roof and rib conditions, the bolting slows down. Pillar dimensions also affect the bolting cycle. If the pillars are larger, there is less bolting to be done and it is easier for the bolter to keep up. If the mine is wet, bolting becomes a more difficult task.

The bolters' workload has been described as the heaviest of all of the job positions. Bolter operators are concerned that the continuous miner operator will have to wait on them to finish bolting the section (13). One-third of the roof bolter operators in the study of six mines with deep-cut approval said that they find themselves hurrying to stay ahead of the continuous miner every day, and another 24% said that this happens to them a few times a week (12). This workload may encourage the bolter to take shortcuts, either to keep up with the miner operator or to get a break. The type of shortcuts mentioned were spacing bolts further apart than the roof plan allows, neglecting to do methane checks, neglecting to drill test holes, and neglecting to check the torques on bolts.

Another important concern is the length of time between bolting. Some believe that the longer the top sits

unbolted, the greater the probability of the roof sagging and possibly falling. Fifty-seven percent of continuous miner operators interviewed were concerned that roof falls in deep cuts were both deeper and have larger surface areas than roof falls in standard cuts. Thirty-seven percent of roof bolters interviewed thought that ground falls may be larger in deep cuts. According to Bauer, Pappas, and Listak (1), deep-cut roof falls averaged 3.0 times larger in area and 1.5 times greater in thickness than nondeep-cut roof falls. Love and Peters (7) found that roof bolter operators thought that the increase in lengths of cuts was causing an increase in the frequency of high roof falls. Bolting in deep-cut sections is considered to be the most dangerous of the mining job categories because of increase in roof fall size and frequency combined with temptations to take dangerous shortcuts to keep up with the miner operator and to go under unsupported roof.

Some areas to be looked into more closely are ventilation, cable handling, roof fall protection, remote reset of the continuous miner, maintenance, safe operating procedures, and remote-control unit design. Hanging ventilation curtain and extending the ventilation tubing in deep-cut sections could result in miners going under unsupported roof (13). This occurrence also depends on the ventilation plan and type of ventilation available. Cable handling, though it is the same task as in a standard cut, may be more difficult because of the longer length of cable to be handled with the deeper cut. Several miner operators thought that they would like to have some protection from

roof and rib falls when operating the continuous miner, but were not sure of the practicality of such a structure. There is significant interest in the ability to remotely reset the breaker on a continuous miner when it trips under unsupported roof during deep-cut mining. Erecting temporary supports is time consuming and places the worker in close proximity to unsupported roof. The temptation is great to quickly go out and reset the breaker because it takes a fraction of the time required to set temporary supports. The USBM has developed alternate methods to remotely reset the machine and test sights are being established.

Currently, the USBM is taking a systematic look at safety issues in deep-cut mining through the use of the questionnaire. The results of these interviews are being used to determine what areas need further examination. The USBM plans to perform task analyses to break down the problem and develop possible solutions. One outcome the USBM plans to develop from this research is a method for mine management to use when implementing new mining technology, whether it is equipment or methods. This will provide them with a tool for evaluating the human factors aspects of technological changes and to better plan and design for these changes. Because of the nature of the data presented here, it would be a mistake to rely solely on these data to make inferences as to the safety of deep-cut mining or to point out all of the areas where problems are occurring.

## CONCLUSIONS

The preliminary task analysis questionnaire has helped to point out several areas of concern with deep-cut mining safety. Several discrepancies were found between the statistical analysis and the questionnaire results, but both can be useful in pointing out areas of concern. The information helps to better define the factors contributing to injuries and fatalities involved in deep-cut sections. The interviews with miners reflect the way they feel about the issues discussed. Many limitations and biases may shape their perceptions, but their viewpoints are considered informative and insightful and are a valuable source of information. This sample was relatively small and was not randomly selected and, for that reason, should not be considered representative of the entire industry.

The USBM is also taking into account discussions with State, Federal, and United Mine Workers of America officials to develop a task analysis approach to researching the controversial aspects of deep-cut mining. The USBM plans to use several types of task analysis methods at two or more mines with varying conditions. As part of the study, the USBM expects to develop a method for mine

operators to evaluate their mine before, during, and after the implementation of the new technology or method to diminish possible human interface problems. In this way, problems can be identified before they show themselves as statistics.

To take a closer look at the visibility aspects of continuous miner operators, the USBM plans to initiate a work sampling-work activity analysis. This will help to determine where the miner operator is positioned in the different phases of the cycle and why. The bolter workload is another area that requires special attention. Since interview data have indicated that the bolter may be taking shortcuts or may be under pressure and hurried, we plan to check the loadings on the bolter, both physical and mental, through ergonomic checklists, task decomposition, and human error analysis. We expect these studies will help to point out the amount of exposure to dangerous work situations, the amount of workload, the most effective type of training needed, and to identify potential errors and their likelihood of occurrence.

## REFERENCES

1. Bauer, E. R., D. M. Pappas, and J. M. Listak. Ground Control Safety Analysis of Extended Cut Mining. BuMines IC 9372, 1993, 24 pp.
2. Bauer, E. R., L. J. Steiner, and C. A. Hamrick. An Update on Extended Cut Mining. Coal Mag., in press.
3. Campbell, J. A., R. Riffey, and P. D. Risner. Deep Cut Remote Control Mining. Paper in Proceedings of the AIME Annual Meeting (Denver, CO, Sept. 1989). AIME, 1989, pp. 101-112.
4. Davis, A. Extended Cuts: An Accident Analysis and Inventory of Approvals. U.S. Mine Saf. and Health Admin., Div. Saf., Coal Mine Saf. and Health, Internal Rep., Apr. 15, 1991, 32 pp.
5. DiCanio, D. G., A. H. Nakata, D. Colvert, and E. G. LaVeque. Accident Cost Indicator Model To Estimate Costs to Industry and Society From Work-Related Injuries and Deaths in Underground Coal Mining. Volume I. Development and Application of Cost Model (contract JO255031, FMC Corp.). BuMines OFR 39(1)-77, 1976, 202 pp.; NTIS PB 264 438.
6. Jayarman, N. I., R. Jankowski, and D. Stritzel. Improving Health, Safety, and Productivity Through the Use of Machine-Mounted Scrubbers. Paper in Proceedings of the Illinois Mining Institute 95th Annual Meeting (Mt. Vernon, IL, Oct. 1, 1987). IMI, 1987, pp. 62-75.
7. Love, A. C., and R. H. Peters. Deep Cuts Present Some New Challenges to Avoiding Unsupported Roof. Holmes Saf. Assoc. Bull., Mar. 1993, pp. 28-30.
8. Love, A. C., and R. F. Randolph. Radio Remote Control Continuous Miner Operator Positioning. New Technology in Mine Health and Safety. Paper in Proceedings of Symposium of Annual SME Meeting (Phoenix, AZ, Feb. 24-27, 1992). SME, 1992, pp. 357-360.
9. Merritt, P. C. As Time Changes, So Do Longwalls. Coal, Feb. 1991, pp. 40-49.
10. \_\_\_\_\_. Longwalls Having Their Ups and Downs. Coal, Feb. 1992, pp. 26-37.
11. Page, S. J., J. C. Volkwein, and F. N. Kissell. Achieving 435-2540 Tonnes Per Shift From Continuous Miner Sections: A Report on the USA's Most Productive Coal Mining Systems. Paper in Proceedings of the AusIMM Illawarra Branch, 21st Century Higher Production Coal Mining Systems—Their Implications (Wollongong, NSW, Australia, Apr. 1988). AusIMM, 1988, 9 pp.
12. Peters, R. H., and A. C. Love. Roof Bolter Operators: Preventers and Victims of Roof Fall Accidents. Holmes Safety Association Bulletin, Jan. 1993, pp. 9-12.
13. Peters, R. H., and R. F. Randolph. Miners' Views About Why People Go Under Unsupported Roof and How To Stop Them. BuMines IC 9300, 1991, 59 pp.
14. U.S. Code of Federal Regulations. Title 30—Mineral Resources; Chapter I—Mine Safety and Health Administration, Department of Labor; Subchapter M—Accidents, Injuries, Illnesses, Employment, and Production in Mines; Part 50—Notification, Investigation, Reports and Records of Accidents, Injuries, Illnesses, Employment, and Coal Production in Mines; Subpart A—General; Section 50.1—Purpose and Scope; 1993.

# CREWSTATION ANALYSIS PROGRAMS—AN EASY TO USE PERSONAL COMPUTER-BASED LIGHTING AND VISIBILITY ANALYSIS SOFTWARE PACKAGE FOR UNDERGROUND MINING EQUIPMENT

By Richard L. Unger<sup>1</sup>

---

## ABSTRACT

Restricted fields of vision are a common problem with the operator of underground mining equipment, particularly in lower seams. Also, when lighting systems are provided underground, they are often positioned where they cause excessive glare. This restricts the visibility around the machines even further. To help address these problems, the U.S. Bureau of Mines has developed an easy

to use personal computer-based software package to aid in the analysis of the visibility and illumination aspects of mining equipment design. The software is widely available for use by mine operators and equipment manufacturers to design new machine illumination systems, as well as to evaluate proposed modifications to existing machines already in use.

## INTRODUCTION

Designing operator compartments (crewstations) for underground mining equipment can be a formidable task. Massive machinery is required to meet production goals while the confined environment imposes severe space restrictions in every direction, most critically in height. As a result of the space limitations, mining equipment operator compartments are frequently smaller than recommended to adequately accommodate most of the population. In fact, crewstations that provide operator accommodations of less than 76 cm (30 in) in height and 60 cm (24 in) in width are not uncommon. In these cramped quarters, visibility is often severely impaired, forcing operators to lean outside of the protection of their crewstations to see. When lighting systems are provided to meet regulatory requirements, they may be positioned where they cause glare, which creates additional problems for miners operating or working around the machines.

Given the difficulty of implementing human factors into mining equipment design, the U.S. Bureau of Mines (USBM) has been attempting to provide the industry with

products to assist in the equipment design process. Several recommendations documents have been developed, including a maintainability design reference (1)<sup>2</sup> and a textbook on human factors in mining (2). In addition, a database containing abstracts of human factors research applicable to mining was developed and made available to anyone with a Digital Equipment Corp. VAX-compatible terminal and modem. One of the most recent USBM research projects that shows promise of impacting how engineers think about the mining equipment design process is the development of the Crewstation Analysis Programs (CAP) package. CAP is a set of computer programs that can be used to analyze some of the human engineering aspects of crewstation design that have particular significance in underground mining. These programs currently include assessments of visibility and illumination in the surrounding work area. Graphics-oriented procedures allow the user to input information needed for the analyses, such as type of mining machinery, lighting systems, and mine layouts. Once this information is identified,

---

<sup>1</sup>Civil engineer, Pittsburgh Research Center, U.S. Bureau of Mines, Pittsburgh, PA.

<sup>2</sup>Italic numbers in parentheses refer to items in the list of references at the end of this paper.

the user may select any of the available analyses. By automating the task of evaluating human factors design issues, CAP will allow engineers to more quickly and easily

experiment with novel crewstation layouts for mining equipment.

## ACKNOWLEDGMENTS

A software project such as CAP requires the expertise of many professionals. The author wishes to acknowledge the contributions of USBM's Pittsburgh Research Center employees Sean Gallagher, research physiologist; Audrey Glowacki, program analyst; Chris Hamrick, industrial

engineer; Alan Mayton, mining engineer; James Rider, operations research analyst; E. W. Rossi, industrial engineering technician; Paul Sonier, computer programmer; and Tris Betts, computer programmer during the development of CAP.

## DESIGN OF CAP

The original version of the software, completed in 1990, was written in FORTRAN for a Digital MicroVAX II computer and required a Tektronix graphics display terminal and mouse, a graphics tablet, and an optional hard-copy unit. The programs have recently been updated and translated to the C language and are now targeted for the widely used 386/486 processors. However, the programs have been designed so that they can be easily transported to other, more powerful platforms, such as work stations. A great deal of effort was expended to develop interactive graphic displays that are "user friendly" to assist in the placement of machines, lamps, and other objects needed to perform the various ergonomic analyses.

CAP is designed much like a simple computer-aided drafting (CAD) program, such as AutoCAD. The center of the screen is taken up by a large view port into the "world," where the user positions three-dimensional models of mines, machines, lamps, glare shields, or any object that is needed by the analysis (fig. 1). The lower right portion of the screen contains the viewing controls, which allow users to change their point of view with respect to the objects in the scene. These controls are always available and activate several zooming, panning, and camera positioning functions. The lower left portion of the screen contains controls for the activation of utilities and positioning aids. These include changing the color or visibility of objects in the scene, turning on a grid to help position objects, toggling the scene from a wire frame to a solid mode, and activating the help screen.

The upper right portion of the screen contains the main menu area of the program. This is a changeable menu several levels deep that controls access to the majority of the functions of the program. From this menu you can open and save files; input mines, machines, and lamps; edit and delete objects; run the analyses; and change the program settings.

The upper left portion of the screen contains a user defined menu. If the users determine that there are functions in the main menu that they use more often than most, the controls for those functions can be permanently displayed here so they are readily available.

Prompts to the user and other pertinent information are displayed in the banner across the top of the screen. Information about what the program is currently doing is generally displayed here. Input into the program is often made through dialog boxes, such as the one presented in figure 2. This particular dialog box allows the user to position a lamp, change its type, or turn it on or off.

The models of machines and lamps used by CAP are usually created with AutoCAD. The AutoCAD DXF file is translated to the CAP file format with a utility program supplied with CAP. However, simple machine models can be created by using either a text editor or a separate model build utility supplied with CAP. Actual mine layouts can be input to CAP by scanning existing mine maps and vectorizing the resultant image into AutoCAD. Mines can also be created from scratch in AutoCAD.

## CAP'S VISIBILITY ANALYSIS

Visibility is a significant problem in the underground mining environment. During the 1980's, the USBM-sponsored research (3) to determine minimum visibility requirements for three classes of underground mining ma-

chines: shuttle cars, scoops, and continuous miners. Using structured interviews and on-site task analyses involving approximately 100 subjects, the researchers first identified the tasks involved in the operation of each class

of vehicle, such as loading, hauling, or unloading. Then, the machine operators were interviewed to identify the visual information required to perform each of these tasks. For example, a shuttle car operator performing a loading task would need to see the positioning of the shuttle car under the tail boom of the continuous miner. While hauling, the location of the shuttle car and any obstacles in the roadway would be required. Following the interviews, the operators were observed while performing the tasks to verify the visual information requirements established in the interviews.

Once the requirements were determined, a methodology was developed to identify specific points in the front-to-back, side-to-side, and vertical planes that must be visible to the operator to satisfy the visual requirements. These points, called visual attention locations (VAL's), were defined in reference to generic locations on the machine. This allowed the VAL's to apply to all configurations of a particular equipment class. For instance, while tramming, a shuttle car operator must be able to spot an obstruction on the ground, while there is enough time to stop the vehicle. The location of one of the VAL's associated with this requirement is described in table 1.

Using this methodology, the procedure involved in computing the location of the VAL is the same even if the length of the equipment, the operator's position, or the height of the equipment is modified.

The results of this VAL research have been incorporated into the CAP package. The CAP visibility model automates the task of determining whether or not the required VAL's are visible to a selected human operator, currently either a 5th percentile female or 95th percentile male. The output is a relative visibility rating for the machine, which can be compared with results of alternative machine designs. CAP also provides both graphical (figs. 3-4) and tabular output to pinpoint any machine parts that obstruct visibility.

**Table 1.—Location of VAL associated with tramming shuttle car**

| <i>Coordinate plane</i> | <i>Position of VAL</i>                                  |
|-------------------------|---|
| Front to back . .       | Front edge of machine plus necessary stopping distance. |
| Side to side . . .      | Machine centerline.                                     |
| Vertical . . . . .      | Floor.  |

## CAP'S ILLUMINATION ANALYSIS

Due to the perpetual darkness of the underground environment, illumination is a factor that must be considered when designing equipment for optimal visibility. Federal regulations specify that certain surfaces within a miner's normal field of vision must be illuminated to  $0.21 \text{ cd/m}^2$  (0.06-fL) while self-propelled mining equipment is being operated. The  $0.21\text{-cd/m}^2$  (0.06-fL) level is a measure of luminance, or photometric brightness. It is a product of the level of illumination (incident light) impinging on a surface and the reflectivity of the surface. USBM research has shown that the  $0.21 \text{ cd/m}^2$  (0.06-fL) level is adequate for most mining tasks and is low enough so that operators will not experience severe adaptation problems when moving from illuminated to nonilluminated areas of the mine (1-5).

Unfortunately, in attempting to meet these illumination standards, mine equipment designers sometimes aggravate another mine lighting problem—glare. There are currently no standards related to glare in underground mining. The regulations state only that designers should attempt to minimize glare when developing machine illumination systems. Obviously, performing all of the calculations required to compute glare for a multitude of machine and lamp types, with the possible combinations running into the thousands, is too tedious and costly to be practical using manual methods. The result is that the designer is

impeded significantly in solving for an optimal illumination system that minimizes glare.

The CAP illumination model eliminates these problems by turning the computational portion of the lighting design task over to the computer. The software allows the lighting designer to concentrate on adjusting the configuration of the illumination system to minimize the potential for glare while still providing enough illumination to conform to the Federal regulations.

To perform an illumination analysis using CAP, the user lays out a lighting system on a machine model. Each lamp has associated with it an illumination profile, previously measured along selected angular orientations from the lens of the lamp. Using these profiles, the software can calculate the light output at any location in the scene. The model does not take into account reflected light, but it can correct for the shadowing effects of machines or other objects in the scene.

In CAP, illumination measurement panels represent the areas (roof, ribs, floor, and face) that must be illuminated to  $21.52 \text{ lx}$  (2.0 fc) to meet the Federal regulations. These panels can be sized and positioned around a machine model (fig. 5). The output of the illumination analysis can be displayed on these panels so that quick comparisons can be made between lamp layouts (fig. 6).



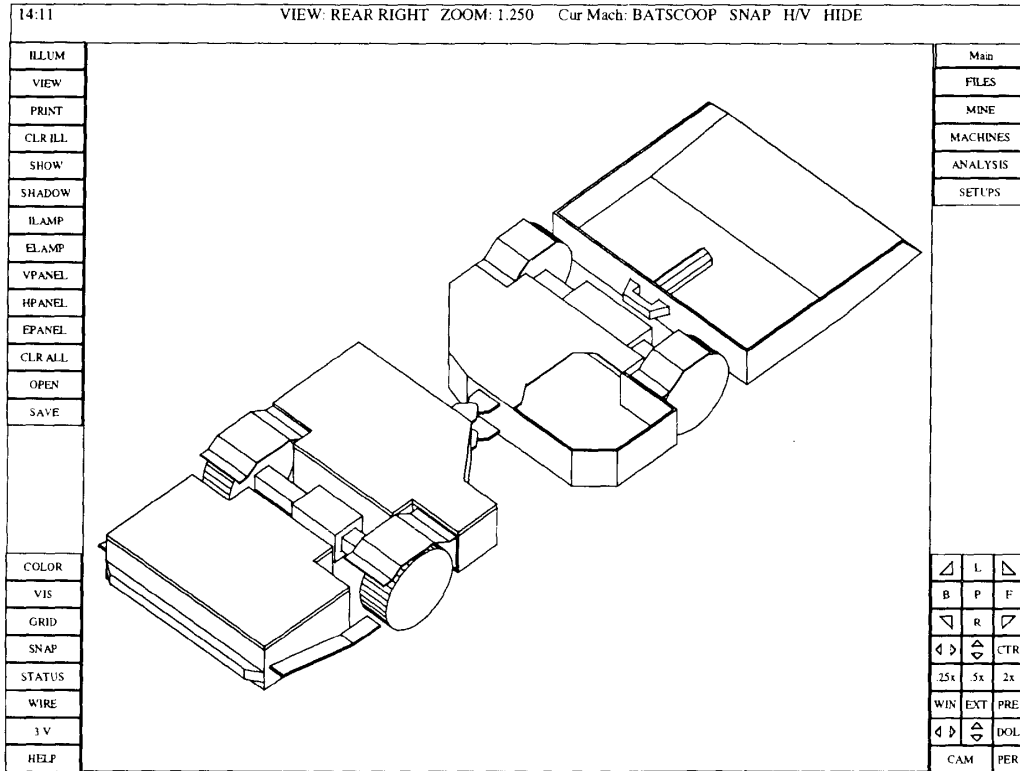

Figure 1.—Default screen layout of CAP with solid model of battery-powered scoop displayed.

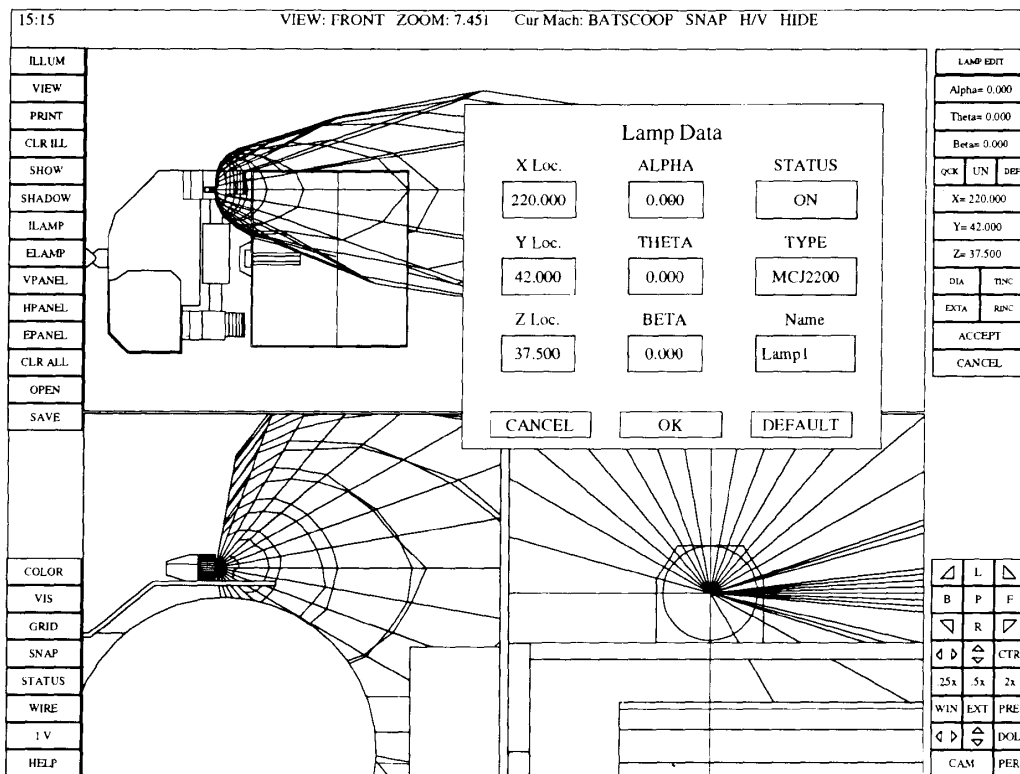

Figure 2.—Screen layout switches to three view modes when objects are being positioned. Dialog box allows input of precise information for objects.

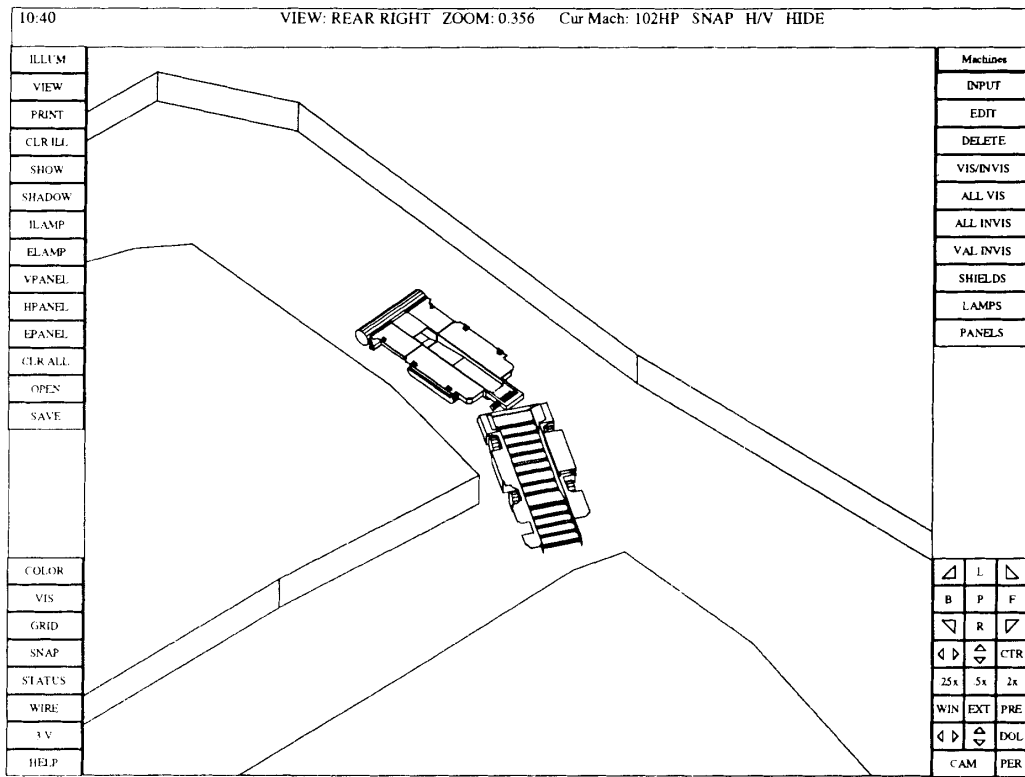

Figure 3.—Shuttle car and continuous miner in entry. Pillars are from scanned mine map.

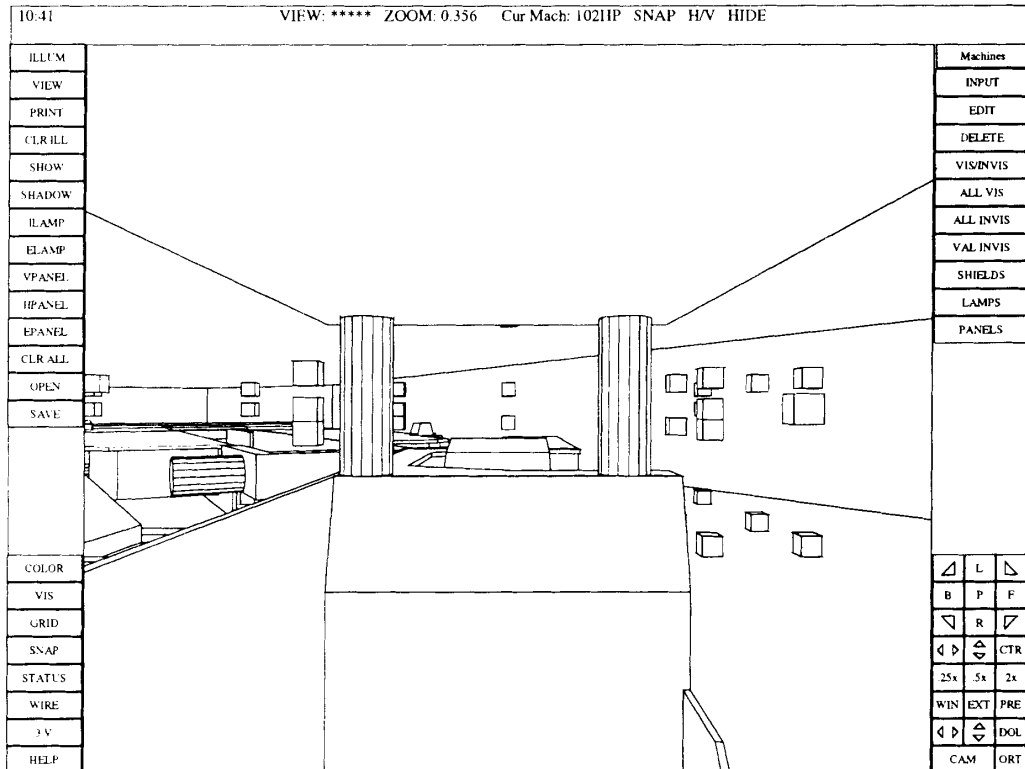

Figure 4.—View from inside shuttle car cab. VAL's are represented as blocks.

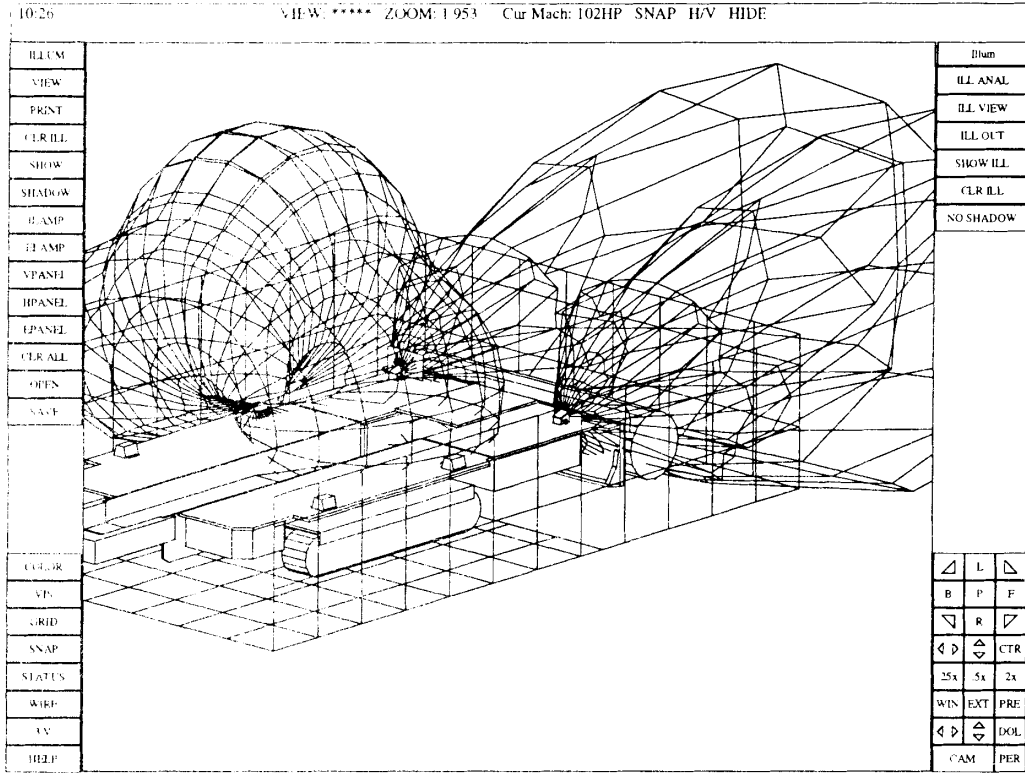

Figure 5.—Continuous mining machine with three of its lamps turned on. There are four illumination measurement panels—one on floor, one at face, and two at sides.

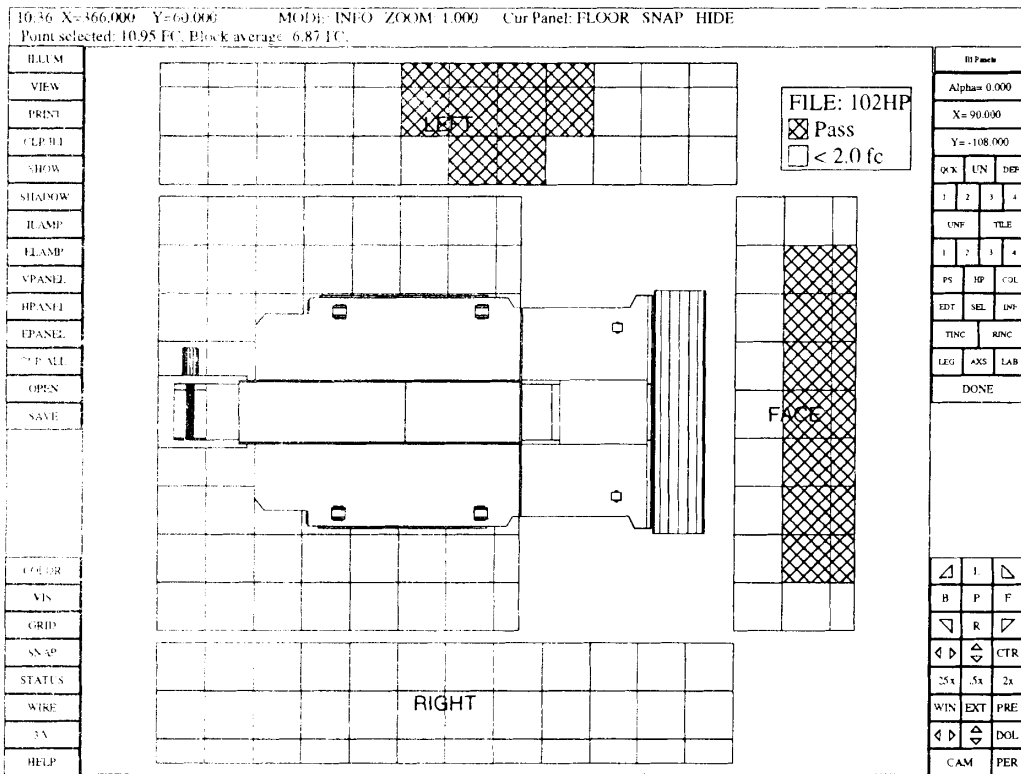

Figure 6.—Illumination measurement panels are unfolded to display results. Crosshatched blocks indicate an average illumination of at least 21.52 lx (2.0 fc).

## SUMMARY

The hardware and software requirements for CAP are listed below.

### *Hardware:*

1. IBM-compatible 386/486 computer.
2. Math coprocessor.
3. 8 Mb of random access memory (RAM) (16 Mb is preferred).
4. At least 10-Mb hard-disk space.
5. Video graphics adaptor (VGA) with 256 color capability (super VGA is preferred).
6. VGA monitor.
7. Microsoft-compatible mouse.

### *Software:*

1. DOS 5.0 or greater.
2. Optional AutoCAD release 11 or 12 with or without advanced modeling extension.

AutoCAD release 11 or 12 with or without the advanced modeling extension (AME) is also necessary to generate complex machine models. However, CAP is supplied with a library of generic mining machines that suit most needs. There is a charge to cover the USBM's licensing fees for the graphics toolkits used by the software.

There are many advantages to using computers to assist in the design of mining equipment. Computers permit quick evaluation and comparison of different systems, such as when trying to optimally position lamps. Information that is difficult or tedious to incorporate into a design with manual methods, such as anthropometric data, can be conveniently accessed. Graphical feedback not only enables the designer to quickly identify potential problems, but also enhances his or her ability to communicate ideas to the client, increasing the likelihood of acceptance of novel designs.

In the future, the USBM plans to enhance CAP with additional capabilities. Work is already underway to automatically generate the path network composed of the entries and crosscuts of the mine model. This will allow computerized timing studies to be performed, such as the time needed for personnel to escape from a section. Operator reach and accommodation models may also be added. These programs would help the designer to determine whether operators from a selected population would be able to fit into the crewstation and reach the controls. As with the illumination and visibility models, the unique requirements of the underground mine worker would be taken into account, including provisions for miners wearing hardhats, metatarsal boots, and self-contained breathing apparatus.

## REFERENCES

1. Conway, E. J., and R. L. Unger. Maintainability Design of Underground Mining Equipment (contract J0145034, VRC Corp.). Volume I—Final Report. BuMines OFR 39-91-V1, 1988, 35 pp; Volume II—Maintainability Design Guidelines. BuMines OFR 39-91-V2, 1988, 181 pp.
2. Sanders, M. S., and J. M. Peay. Human Factors in Mining. BuMines IC 9182, 1988, 153 pp.
3. Sanders, M. S. Visual Attention Locations for Operating Continuous Miners, Shuttle Cars, and Scoops: A Summary (contract J0387213, Canyon Res. Group, Inc.). BuMines OFR 29(2)-82, 1981, 67 pp.; NTIS PB 82-187949.
4. Lewis, W. H. Underground Coal Mine Lighting Handbook. (In two parts ) 1. Background. BuMines IC 9073, 1986, 42 pp.
5. \_\_\_\_\_. Underground Coal Mine Lighting Handbook. (In Two Parts.) 2. Application. BuMines IC 9074, 1986, 89 pp.

# IMPACT OF MAINTAINABILITY DESIGN ON INJURY RATES AND MAINTENANCE COSTS FOR UNDERGROUND MINING EQUIPMENT

By Richard L. Unger<sup>1</sup> and Kirk Conway<sup>2</sup>

---

## ABSTRACT

In the U.S. underground coal mining industry, maintenance of the mining equipment accounts for over 30% of the lost-time injuries. In addition, the steadily increasing cost of maintaining this equipment has focused attention on the need to find ways to contain or reduce these expenses. To obtain a better understanding of why maintenance injuries occur, the U.S. Bureau of Mines has conducted a research project to analyze the design of underground mining equipment with respect to ease of maintenance and maintainer safety. The objective was to identify design factors contributing to these high injury

rates and maintenance costs. The work included a review of relevant maintainability design literature, analysis of maintenance-related accident data, field reviews of equipment design in underground operating environments, and interviews with mine maintenance personnel and equipment manufacturers. Based on the findings, a set of maintainability design recommendations have been prepared and published. The documents include basic maintainability engineering information for equipment designers, as well as a **buyers' guide** to assist purchasers of mining machinery in evaluating the maintainability of equipment.

## INTRODUCTION

In the 1950's underground coal mining equipment consisted of relatively simple but rugged machines powered by electric motors and hydraulics. These machines were used to cut, dig, load, and transport coal from the mine face to the surface. The machines were maintained by mine maintenance personnel armed with a basic knowledge of hydraulics, electricity, and mechanical design. These maintainers were expected to repair all of the equipment at the minesite using only simple hand tools.

Over the years, the basic mining machine has been transformed into powerful, complex mining systems. To boost productivity, the horsepower and size of the original machines have been increased. To enhance unit productivity, machines were designed to perform multiple functions.

To increase throughput, continuous miners, longwall and shortwall systems, and continuous haulage were introduced. To reduce injuries, numerous safety features have been added to the machines. To protect the miners' health, environmental control systems have been tacked on.

With few exceptions, however, little improvement in the basic design of equipment for maintainability has been made. In many cases, equipment maintainability has been sharply decreased. Many of the above design changes were achieved by simply modifying existing machine designs. On certain mining machines, sharp reductions in maintainability and, consequently, maintainer safety were experienced as a result of added-on safety and environmental systems designed only with the machine operator in mind.

---

<sup>1</sup>Civil engineer, Pittsburgh Research Center, U.S. Bureau of Mines, Pittsburgh, PA.

<sup>2</sup>Senior staff scientist, VRC Corp., Monterey, CA.

Even with all of the above changes, the maintainer is still expected to service and repair these ever more complex machines. This must be accomplished in an operational setting providing little in the way of new maintenance tools, procedures, automatic test equipment, or other technology-based maintenance aids and in an environment that usually lacks proper lighting and clearances. All in all, there has been little concern directed at the well being of the maintainer. It is no wonder that equipment maintenance has traditionally accounted for one-third of all lost-time injuries in underground mines. This injury rate persists in spite of concerted efforts on the part of mine management to minimize accidents, U.S. Mine Safety and Health Administration (MSHA) efforts to enforce health and safety rules, and USBM efforts to conduct safety research.

In addition to the safety of the maintainer, another area of concern has been the escalating cost of mining equipment maintenance. Underground equipment maintenance typically accounts for 25% to 35% of the total mine operating costs. These costs have continued to rise over the years despite efforts to contain them. Mine operators have attempted to gain control of these steadily increasing costs through (1) optimization of scheduled maintenance operations, (2) reductions in maintenance staff, (3) reduction and better control of spare parts inventories, (4) contracting for maintenance support, and (5) deferring nonessential maintenance.

Unfortunately, little attention has been focused on the design of the mining machine itself with respect to

maintenance costs. The cost of maintaining a machine is, after all, a direct function of—

1. Maintenance frequency and failure interval for the machine and major components.
2. Time and labor required to complete unscheduled maintenance actions.
3. Time and labor required to complete routine maintenance tasks.

A review of current mining equipment design suggests that considerable improvements in safety, as well as substantial cost savings, could be achieved with relatively simple design improvements. For example, by relocating difficult to access, but frequently replaced hydraulic valves and hoses on certain roof bolters, this 1-h plus removal and replacement (R/R) task is reduced to a 5-min operation. Improved component accessibility and increased ease of R/R tasks reduces the maintainer's risk of injury. Numerous other maintenance improvements could be realized with minor design changes on new or existing equipment. As part of its program to enhance the safety of mine workers, the U.S. Bureau of Mines (USBM) completed a project entitled "Assessment of the Maintainability Design of Underground Mobile Mining Equipment," which was performed by VRC Corp. The final report was published in 1988 (7).<sup>3</sup> Other papers published by the USBM based on this work are listed in the references (2-6).

## DESIGN-INDUCED MAINTAINABILITY PROBLEMS

The USBM analyzed underground coal mining equipment with respect to design for maintenance and maintenance personnel safety. A maintainability design review and human factors analysis of equipment was completed at nine operational coal mines. Mining machines in large and small mines operating in high- and low-seam coal were surveyed. Conventional, continuous, and longwall operations were included. Shuttle cars, scoops, roof bolters, continuous miners, longwall equipment, undercut machines, face drills, utility vehicles, and personnel carriers were reviewed. The survey identified the following design limitations that directly impacted maintenance time, cost, and personnel safety.

1. Accessibility problems: Inability of maintenance personnel to access failed or suspected components to inspect or remove and replace them. Accessibility problems resulted from—

- a. Inadequate access opening size.

b. Poor layout of components in a compartment, necessitating R/R of nonaffected parts to access the failed units.

c. Inability to access mounting bolts or connectors or to use required tools.

d. Installing components in inaccessible interior cavities and running cables inside the frame or chassis where they cannot be reached.

e. Locating fasteners and mechanical interfaces where they physically cannot be reached unless the machine is partially or completely disassembled.

2. Inadequate component-handling capability and component-machine interface design.

3. Inadequate design for routine maintenance: Inability to quickly remove and replace leaking hydraulic hoses and water lines, to remove and replace failed hydraulic valves,

---

<sup>3</sup>Italic numbers in parentheses refer to items in the list of references at the end of this paper.

to perform routine lubrication and to perform visual and physical inspections.

4. Inadequate fault isolation capability:

a. Difficulty determining the precise cause and location of a failure.

b. Accessing components to perform visual inspections and to perform checks.

c. Limited or no designed-in fault diagnostic capabilities.

d. Lack of effective failure indices.

5. Increased maintenance burden resulting from poor design and placement of components, subjecting them to impact damage.

6. Poor design with respect to resources available: Need for maintenance personnel to "jerry-rig" tools, to handle 45-kg (100-lb) to 450-kg (1,000-lb) components, and to substitute brute human strength to overcome poor component interface design or lack of requisite tools.

7. Equipment complexity resulting from poor layout: Crowding of components into compartments without regard to the need to maintain or replace individual items, overlaying hoses and power cables, and making R/R needlessly difficult.

8. Design conveniences: Multiplying the number of valves, connectors, and other high-frequency replacement components as a design convenience.

## EQUIPMENT DESIGN AND MAINTENANCE SAFETY

A summary of maintenance-related accident statistics in the underground coal mining industry in 1981 is presented in table 1. A majority of the maintenance injuries involve strains-sprains, low back injuries, and crushing injuries. These injuries typically occur during R/R of components weighing from 16 kg (35 lb) to over 450 kg (1,000 lb) (7).

In many instances, two or more workers with crowbars, 4 by 4's, or other makeshift tools must manually remove the component from the mining machine or lift it into place so that it can be secured. In most cases, no provisions have been made during component-machine interface design to provide for mechanical assist in the R/R process (7). A review of mining equipment design

suggests that, in many cases, this designed-in assistance could be readily achieved. For example, adding guide pins to hold components while they are being bolted or unbolted. If incorporated, the guide pins would minimize personnel exposure to the types of injuries identified in table 1. They would also expedite the R/R process itself.

One of the objectives of maintainability engineering is to minimize the need to manually handle components. With proper design and engineering, all components should be provided with mechanical means to interface them with the machine itself. With optimized maintenance design, it is reasonable to assume a substantial reduction in maintenance-related accidents.

Table 1.—Maintenance-related injuries in underground coal mining industry in 1981 (8)

| Code  | Type of accident          | Mine maintenance   |            | Machine maintenance |            |
|-------|---------------------------|--------------------|------------|---------------------|------------|
|       |                           | Number of injuries | % of total | Number of injuries  | % of total |
| 1     | Stationary object         | 185                | 5.6        | 272                 | 8.9        |
| 2     | Moving object             | 2                  | Neg.       | 6                   | Neg.       |
| 3     | Concussions               | 0                  | 0          | 1                   | Neg.       |
| 4     | Falling object            | 611                | 18.4       | 511                 | 16.8       |
| 5     | Flying object             | 62                 | 1.9        | 62                  | 2.0        |
| 6     | Rolling object            | 62                 | 1.9        | 18                  | Neg.       |
| 8     | Struck by, NEC            | 231                | 6.9        | 265                 | 8.7        |
| 17    | Fall, walkway             | 8                  | Neg.       | 7                   | Neg.       |
| 18    | Fall on object            | 3                  | Neg.       | 5                   | Neg.       |
| 21    | Caught, moving-stationary | 169                | 5.1        | 190                 | 6.3        |
| 22    | Caught, moving objects    | 6                  | Neg.       | 9                   | Neg.       |
| 23    | Caught, collapse          | 2                  | Neg.       | 0                   | 0          |
| 24    | Caught, NEC               | 261                | 7.9        | 292                 | 9.6        |
| 25    | Rub, abrade               | 3                  | Neg.       | 1                   | Neg.       |
| 26    | Bodily reaction, NEC      | 2                  | Neg.       | 2                   | Neg.       |
| 27    | Overexert, lifting        | 1,132              | 34.1       | 793                 | 26.1       |
| 28    | Overexert, push-pull      | 78                 | 2.3        | 147                 | 4.8        |
| 29    | Overexert, welding        | 112                | 3.4        | 13                  | Neg.       |
| 30    | Overexert, NEC            | 360                | 10.8       | 373                 | 12.3       |
| 33    | Contact hot object        | 3                  | Neg.       | 26                  | Neg.       |
| 36    | Inhale noxious fumes      | 1                  | Neg.       | 8                   | Neg.       |
| 38    | Absorb noxious fluid      | 26                 | Neg.       | 25                  | Neg.       |
| 39    | Flash burns, electrical   | 0                  | 0          | 2                   | Neg.       |
| 42    | NEC                       | 1                  | Neg.       | 2                   | Neg.       |
| 43    | Insufficient data         | 2                  | Neg.       | 6                   | Neg.       |
| Total |                           | 3,322              | NAp        | 3,036               | NAp        |

NEC Not elsewhere classified.

Neg. Negligible

NAp Not applicable.

## HUMAN ERROR AND DESIGN FOR MAINTENANCE

So-called human error is a problem that must be addressed in design as well as during operation and maintenance of complex equipment (9-13). Errors may occur in operating mining machines, performing maintenance tasks, or in making management decisions. Fortunately, most human errors result in limited negative consequences (e.g.; lost time and production waste). In many cases, the error ends up costing the party involved time or money. Unfortunately, in a smaller percentage of cases, people are injured or killed and equipment destroyed.

Dramatic evidence of the impact of a maintenance error was the 1979 American Airlines DC10 crash that killed 272 people. This crash was directly attributed to maintenance error. The probability of recurrence of this type of error was reduced substantially by means of a simple component design change.

### OPERATIONALLY INDUCED ERRORS

What does human error have to do with mining equipment maintainability? In an interesting review of the subject, researchers report that a significant percentage of all operational equipment failures are human error induced (11-12). In fact, human error accounted for—

1. Fifty to seventy percent of all electronics failures.
2. Sixty to seventy percent of all aircraft and missile failures.
3. Twenty to thirty percent of all mechanical failures.

Many of these are operator induced errors resulting in machine damage or prolonged down time. Maintenance requirements could be reduced by designing out these types of errors. Other errors are made by maintenance personnel while performing maintenance tasks (13).

### MAINTENANCE-INDUCED ERROR RATES

The above study also reports that 20% to 25% of all failures are directly traceable to maintenance errors. A separate study found 25% of all maintenance problems to be human error induced during maintenance operations (11). Another study reports human error rates for specific types of maintenance tasks. These data, summarized in table 2, were derived from an earlier study (13). The values are indicative of the error rates found in many industrial and military settings.

Another maintenance study reports that the average human reliability in adjusting or aligning tasks is 0.0987 (13). This value suggests that out of every 1,000 attempts to adjust a component, you can expect 13 errors. Many of these errors could be eliminated through improved design

of the component-machine interface. Although not directly applicable to underground mining operations, the above error rates are suggestive of the types, frequencies, and sources of human errors in maintenance. It is reasonable to assume that similar error-rate patterns could be expected in mine maintenance operations.

**Table 2.—Representative maintenance task error rates (13)**

| Action          | Object          | Error description            | Error rate <sup>1</sup> |
|-----------------|-----------------|------------------------------|-------------------------|
| Observe ..      | Chart . . . . . | Improper switch action       | 1,128                   |
| Read . . . .    | Gage . . . . .  | Incorrectly read . . . . .   | 5,000                   |
| Read . . . .    | Instruction     | Procedural error . . . . .   | 64,500                  |
| Connect ..      | Hose . . . . .  | Improperly connected         | 4,700                   |
| Torque ...      | Fluid lines     | incorrectly torqued . . . .  | 104                     |
| Tighten ..      | Nuts, bolts     | Not tightened . . . . .      | 4,800                   |
| Install . . . . | Nuts, bolts     | Not installed . . . . .      | 600                     |
| Install . . . . | O rings . . . . | Improperly installed . . . . | 66,700                  |
| Solder . . . .  | Connection      | Improper solder joint . . .  | 6,460                   |
| Assemble        | Connector       | Bent pins . . . . .          | 1,500                   |
| Assemble        | Connector       | Missing part . . . . .       | 1,000                   |
| Close . . . .   | Valve . . . . . | Not closed properly . . . .  | 1,800                   |
| Adjust . . . .  | Linkage . . . . | Improperly adjusted . . . .  | 16,700                  |
| Install . . . . | Orifice . . . . | Incorrect size installed     | 5,000                   |
| Machine ..      | Valve . . . . . | Wrong size drill and tap     | 2,083                   |

<sup>1</sup>Per million operations.

### ERRORS IN UNDERGROUND MINING EQUIPMENT MAINTENANCE

Representative underground mining maintenance errors have been identified, with the major types summarized in table 3. It was also possible to identify a number of factors contributing to maintenance-related human error. These include—

1. Confined workspaces: Crowded equipment bays.
2. Inability to make visual inspections.
3. Inaccessible components:
  - a. Lube points that could not be reached.
  - b. Adjustment points that are hard to access.
  - c. Major components that could not be reached.
4. Poor layout of components in a compartment.
5. Inappropriate placement of components on machine.
6. Poor or no provision for hose and cable management.
7. Lack of troubleshooting guides and tools.
8. Lack of positive component installation guide pins and other installation controls.
9. Insufficient task inspection and check-out time.
10. Cumbersome or inadequate manuals.
11. Excessive weight of components being manually handled.



**Table 3.—Typical mining equipment maintenance errors**

| <i>Frequency</i> | <i>Type of error</i>   |
|------------------|--|
| I . . . . .      | Install incorrect component.   |
| S . . . . .      | Omitting a component.<br>Parts installed backwards.<br>Failure to properly torque.<br>Failure to align, check, or calibrate.<br>Use of incorrect fluids, lubricants, or greases.   |
| O . . . . .      | Reassemble error.<br>Failure to seal or close.<br>Error resulting from failure to complete task due to shift change.<br>Failure to detect while inspecting.<br>Failure to lubricate.<br>Failure to act on indicators of problems due to workload, priorities, or time constraints.<br>Failure to follow prescribed instructions. |

I Infrequent (less than once per year).

S Somewhat frequently (2 to 5 times per year).

O Often (over 5 times per year).

Listed below are several engineering design improvements that reduce maintenance errors:

1. Improved component-machine interface:
  - a. Design interface so that the component can only be installed correctly (e.g.; irregular bolt pattern).

- b. Provide mounting pins and other devices to support a component while it is being bolted or unbolted.
2. Improved fault isolation design:
  - a. Designate test points and procedures.
  - b. Provide built-in test capability.
  - c. Clearly indicate direction of fault.
3. Improved indicators, warning devices, and readouts to minimize human decisionmaking.
4. Use of operational interlocks so that subsystems cannot be activated if they are incorrectly assembled-installed.
5. Use of positive decision guides to minimize human guesswork:
  - a. Arrows to indicate direction of flow.
  - b. Correct type of fluids or lubricants.
  - c. Correct hydraulic pressures.
6. Design to facilitate detection of errors:
  - a. Locate connections on front of component to facilitate visual inspections.
  - b. Lay equipment out in a logical flow sequence.

If maintainer-induced errors could be reduced by 50%, overall equipment availability would be increased by more than 10%. These reductions can be achieved through improved design.

## MAINTENANCE SAFETY COSTS

Maintenance operations account for a significant percentage of all coal mining accidents and injuries. MSHA accident statistics for 1984 suggest that maintenance-related injuries account for 33% of all lost-time accidents (14). These accidents impact mine operating costs in the form of decreased productivity, increased benefits costs, and increased insurance rates.

Many injury accidents can be directly traced to equipment design in this and other studies (6). Inadequate

accessibility, lack of means to lift and maneuver heavy components, inability to visually observe the maintenance task being performed, inadequate maintenance safeguards, and other design-induced problems account for a significant percentage of maintenance accidents. Improved accessibility, enhanced component-machine interface, and simplified maintenance procedures could have a positive impact on these statistics. Improved maintenance safety will reduce maintenance as well as overall operating costs.

## COST OF MINING EQUIPMENT MAINTENANCE

Reliable maintenance cost data are not currently available across the underground coal mining industry, although several industry estimates are available. These estimates, however, vary substantially from source to source.

Informal data gathered over the past several years reveal that equipment maintenance costs range from 20%

to over 35% of total mine operating costs. Actual values varied based on the size and type of mine, mining technology employed, management attitude toward maintenance, and other factors.

## FACTORS CONTRIBUTING TO MAINTENANCE COSTS

The current review of mine maintenance operations suggested that the following factors contribute to equipment maintenance costs:

1. Management attitude towards maintenance: Attitudes range from "when it breaks—fix it" to strong top management support for professionally planned and implemented preventive maintenance (PM) programs geared to reducing unscheduled equipment down time and to controlling maintenance costs.

2. Skill of maintenance management personnel: The skills required to organize and manage an effective mine maintenance program differ from the skills required to perform "hands on" maintenance of mining equipment. Poor maintenance management contributes to increased costs.

3. Maintenance training and experience: Poor maintenance skills on the part of maintainers resulting from inadequate training; lack of job performance aids, manuals and guides; and complexity of maintenance tasks.

4. Maintenance environment: It is an entirely different task to maintain a continuous miner in a 91-cm (36-in) coal seam than it is to maintain one in a well-equipped standing height underground repair shop.

5. Age of equipment: Older equipment tends to be smaller and inherently simpler in design. As a result, older machines are somewhat simpler to maintain. Newer equipment tends to be larger, more complex, and overlaid with numerous "add-on" systems and components, making accessibility and the basic maintenance process more difficult.

6. Maintenance errors: Reliable data are not available, but most maintenance personnel interviewed informally concede that maintenance errors contribute substantially to overall maintenance costs. Removing and replacing nonfailed items, troubleshooting one system too long, not replacing suspected components during a previous maintenance opportunity, failing to install or repair a component correctly, failing to test a component prior to reassembly, and related errors account for an estimated 10% to 25% of all maintenance time.

7. Design of equipment itself: Certain makes and models of mining equipment are designed to facilitate maintenance and repair, while the basic design of other models hinder maintenance actions.

8. Regulatory compliance: Safety and environmental control devices required for regulatory compliance add to the complexity and increase maintenance costs.

## COST OF DESIGN FOR MAINTAINABILITY

The value or worth of any machine resides in its ability to generate a return on investment. If a machine has an initial cost of "Y" dollars, it must produce "Y plus" dollars of coal to have a positive worth or value. On this assumption, it is possible to illustrate the cost savings derived from improved design for maintainability using simple economic models.

There are many economic models that can be used to compute the worth of equipment. For this discussion, a simplified model will suffice. Figure 1 presents an overview of this model. (Readers interested in a more comprehensive treatment are referred to references 8, 15, 16, and 17.) The following model suggests that the worth (W) of a piece of mining equipment can be defined as—

$$W = I + C + M - P,$$

where I = initial purchase price of machine,

C = cost per hour to operate machine,

M = maintenance costs per hour of operation,

and P = production value per hour of operation.

The initial purchase price of the piece of equipment is fixed or "inelastic." It is set at the time of purchase. The price is simply amortized per hour over the useful life of the machine. Of course, the more hours of production it sees, the lower the amortized cost per hour.

The cost per hour to operate the machine is relatively fixed or "inelastic" and composed of the following cost elements:

1. Labor costs for the machine operator(s), support personnel, and immediate production supervision.
2. General overhead costs, which include insurance, utilities, royalties, brokerage, and related costs.
3. Cost of mining supplies and materials.
4. Other management and administrative costs.

The cost to maintain consists of the following cost elements, some of which are fixed and some of which are relatively "elastic":

1. Labor costs for maintenance personnel.
2. Cost of spares, replacement parts, and supplies.
3. Loss of production during maintenance.
4. Cost per hour of idled machine operators.
5. Other maintenance-related costs.

The costs of replacement parts and maintenance supplies are also relatively inelastic. Certain savings can be realized with careful buying. The cost of labor and other overhead items, on the other hand, are a function of the duration of repair time for unscheduled corrective maintenance (CM) actions.

More importantly, a reduction in repair time for downed equipment contributes positively to the overall worth equation by increasing the time available for production. Thus, decreased time to repair not only reduces direct maintenance costs, but also increases the production per hour, thereby offsetting other costs. If we look at the maintenance process again, we observe many points at which time can be saved through improved design for maintenance (fig. 2). Several of these points include—

1. Prediction of pending failures to facilitate PM scheduling.
2. Decreased fault isolation time.
3. Reduced component access time.
4. Decreased inspection and diagnosis time.
5. Diminished component R/R time.
6. Reduced test and alignment time.

A review of underground maintenance task completion times at two large mining operations revealed that the time required to change hydraulic hoses on continuous miners and shuttle cars ranged from 15 min to over 3 h. The estimated average time for a failed hydraulic hose R/R was over 35 min. Examination of these machines revealed that the time differences were directly linked to accessibility of the hose connectors. In several cases, two or more nonfailed components had to be removed to access a failed hose connection.

By relocating several components or rerouting hoses, maintenance personnel could directly access over 90% of all hydraulic line connections on the surveyed machines. This would have reduced the average hydraulic line R/R time to well under 15 min per replacement.

If a maintainability design standard for new or rebuilt machines specified that all hydraulic hoses had to be removed or replaced in less than 15 min, the average repair time for this task could be reduced 50%. Similar performance criteria could be developed for other maintenance tasks. The result would be significant reductions in all maintenance task completion times.

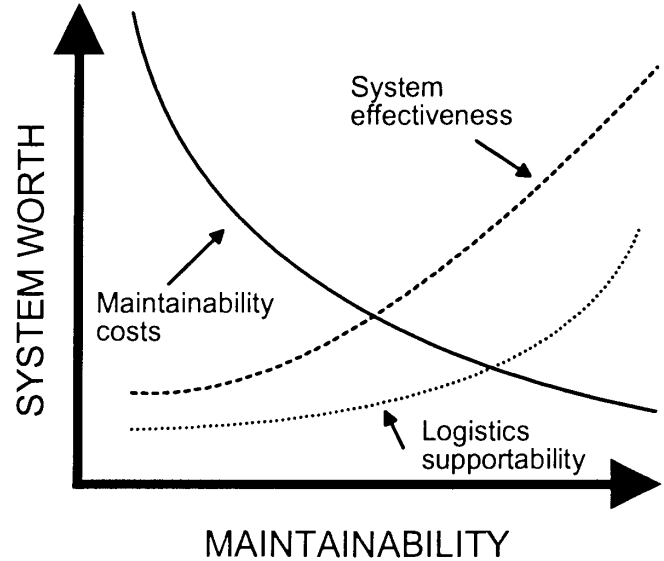

Figure 1.—System worth versus maintainability (13).

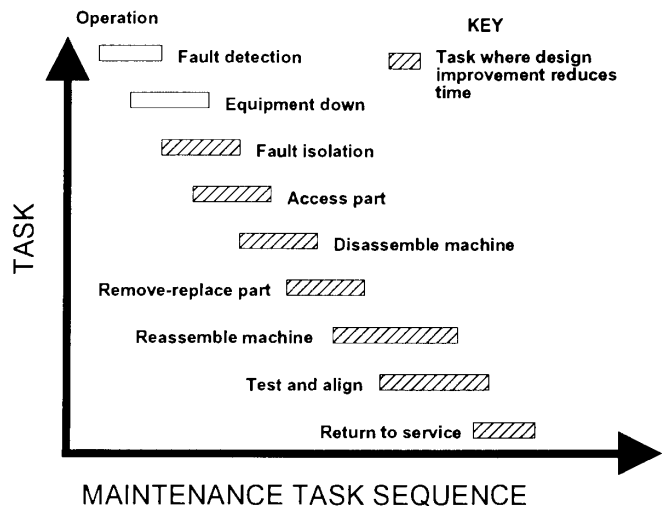

Figure 2.—Sample maintenance task sequence.

Evidence from other civilian and military research efforts suggest that PM and CM task time reductions of from 40% up to 70% are achievable with planned maintainability design efforts (15-16).

## PRODUCTIVITY

Productivity represents the other side of the maintainability issue. Productivity is a function of the machine producing coal. Hence, it is directly impacted by the speed

and ease with which the mining machine can be repaired and returned to service. The more rapidly a machine can be returned to production, the more productive it will be.

Productivity is expressed in terms of the units (of coal) produced by a machine per unit of time. The greater the number of hours the machine is available to produce coal, the more productive it is going to be. For example, suppose that a continuous miner has a rated production capacity of 907 kg/h (100 st/h). Further, suppose that the same miner requires an average of—

1. One hour of PM per shift, and
2. One hour of CM per shift.

Assume that the mine operates the equipment during two production shifts per day for 300 d/yr. Hence—

$$(300 \text{ h PM} + 300 \text{ h CM}) \times 2 \text{ shifts} = 1,200 \text{ h/yr.}$$

If the CM and PM time could be reduced by 50%, this would result in the following increase in productivity:

$$(1,200 \text{ CM and PM h/y}) \times 0.5 = 600 \text{ h/yr savings}$$

$$600 \text{ h/yr} \times 90,000 \text{ kg/h (100 st/h)} = 54 \text{ million kg/yr}$$

$$(60,000 \text{ st/yr}) \text{ per machine increase.}$$

If the mine were operating eight miners, this 54 million kg/yr (60,000 st/yr) per machine increase would be the equivalent of adding another miner with no additional increase in cost.

$$54 \text{ million kg/yr (60,000 st/yr)} \times 8 \text{ miners}$$

$$= 432 \text{ million kg (480,000 st) annual increase.}$$

Actual analysis of the design of three different continuous mining machines during this project suggested that productivity improvements exceeding the above example could be achieved with relatively simple redesign efforts.

## CONCLUSIONS

The following conclusions were derived from this study of maintainability in the underground mining industry:

1. There is little evidence of the systematic application of maintainability design principles, concepts, or criteria to the design of operational underground coal mining equipment.
2. Similarly, there is little evidence of systematic application of human factors engineering principles, concepts, or criteria being applied to the design of this equipment with respect to maintenance.
3. Reduced task completion times and fewer maintenance problems were reported for the 10 most frequently performed maintenance tasks on older and smaller machines than for newer more complex equipment. This appears to be the result of simpler design on the older equipment.
4. Increased task complexity and completion times were generally reported for the newer, larger mining machines. This appears to be the result of increased design complexity, larger and heavier components to be handled,

overlying of safety and environmental control systems over the basic machine design, and inadequate accessibility to components.

5. For certain machines, heavy maintenance tasks could be performed on the surface or in high roof underground shops equipped with requisite lifting devices. The same maintenance tasks were extremely difficult, time consuming, and risky to perform at the mine face, where they often have to be completed.

6. With the exception of machines produced by 1 small mining equipment manufacturer, maintenance task completion times for the 10 most frequently performed maintenance tasks could be reduced from 10% to 30% or more with relatively simple design improvements.

7. Application of accepted human engineering design standards and criteria could substantially reduce maintenance risk. Over one-third of the reviewed maintenance lost-time injuries were traceable to equipment design deficiencies. Estimates of actual maintenance risk reduction resulting from redesign of the equipment could not be derived from the data.

## REFERENCES

1. Conway, E. J., and R. L. Unger. Maintainability Design of Underground Mining Equipment (contract J0145034, VRC Corp.). Volume I—Final Technical Report. BuMines OFR 39-91-V1, 1988, 35 pp., NTIS PB 91-241885. Volume II—Maintainability Design Guidelines. BuMines OFR 39-91-V2, 1988, 181 pp., NTIS PB 91-241893.
2. \_\_\_\_\_. Maintainability Design of Mobile Underground Mining Equipment. Paper in Human Engineering and Human Resources Management in Mining. BuMines IC 9145, 1987, pp. 61-65.
3. Conway, E. J., and R. L. Unger. Maintainability Design of Underground Mobile Mining Equipment. Paper in Annual Review of International Mining Technology and Development. MINTECH 1989.
4. Unger, R. L., and E. J. Conway. Maintainability Design of Underground Mining Machinery. Proceedings of the AIAA/NASA Symposium on the Maintainability of Aerospace Systems (Anaheim, CA, July 26-27, 1989). AIAA, 1989.

5. Conway, K., and R. L. Unger. Design of Mining Equipment for Maintainability, *Industrial Ergonomics—Case Studies*. Ind. Eng. and Manage. Press, 1991, pp. 317-334.
6. Conway, E. J., and R. L. Unger. Recommendations Concerning the Maintainability of Underground Coal Mining Equipment. Paper in Proceedings of the SME Annual Meeting (Phoenix, AZ, 1992). SME, 1992, pp. 297-308.
7. Conway, E. J., and W. A. Elliott. Mine Maintenance Material Handling: Volume I—Final Technical Report (contract H0113018, Canyon Res. Group, Inc.). BuMines OFR 13(1)-89, 1988, 44 pp.; NTIS PB 89-168967.
8. Foster, J., D. Phillips, and T. Rodgers. Reliability, Availability and Maintainability. M/A Press, 1981, 265 pp.
9. Conway, E. J., and M. S. Sanders. Recommendations for Human Factors Research and Development Projects in Surface Mining (contract J0395080, Canyon Res. Group, Inc.). BuMines OFR 211-83, 1982, 86 pp.; NTIS PB 84-143650.
10. Taylor, R. J. An Introduction to Error Analysis. Oxford Univ. Press, 1982, 270 pp.
11. Christensen, J. M., J. H. Howard, and B. S. Stevens. Field Experience in Maintenance, in *Human Detection and Diagnosis of System Failures*, ed. by J. Rasmussen and W. B. Rouse. Plenum, 1981, 363 pp.
12. U.S. Government Accounting Office. Effectiveness of U.S. Forces Can Be Increased Through Improved Weapon System Design. GAO Rep. to Congr. PSAD-81-17, 1981, 23 pp.
13. Rasmussen, J., and W. Rouse (eds.). *Diagnosis of System Failures*. Plenum, 1981, 363 pp.
14. U.S. Mine Enforcement and Safety Administration (Dep. Interior). Analysis of Injuries Associated With Maintenance and Repair in Metal and Non-Metal Mines. MESA Inf. Rep. 1058, 1985, 34 pp.
15. Dhillon, B. S. *Human Reliability*. Pergamon, 1986, 239 pp.
16. Dhillon, B. S., and H. Reiche. *Reliability and Maintainability Management*. Van Nostrand Reinhold, 1985, 240 pp.
17. Bird Engineering-Research Associates, Inc. *Maintainability Engineering Handbook*. Nav. Ordnance Syst. Command contract NOOO17-68-4403, 1969, 310 pp.

## APPENDIX.—MAINTAINABILITY DESIGN CHECKLIST

This appendix presents an example maintainability design checklist for coal mining equipment. The purpose of the checklist is to provide a summary of design review points for the maintainability assessment of new or existing underground equipment. It specifically focuses on the identification of equipment design features, tasks, or procedures that impact equipment down time, repair costs, labor hours, and maintainer skill level requirements.

Some of the checklist points are general in nature. The checklist was designed to be used across all categories of underground equipment. The intent is to draw attention to design features and maintenance procedures that will increase maintainability requirements. The reader is encouraged to adapt this checklist to site-specific or machine-specific requirements by—

1. Inserting specific performance criteria for various categories of maintenance tasks. For example, all hydraulic lines on a shuttle car should be replaceable in 15 or 25 min.

2. Adding or deleting checklist items for different categories of equipment. Environmental control equipment, for example, would be included on face equipment and not on shuttle cars or mantrips.

3. Adding additional checklist items based on site or equipment specific maintenance histories or experience, company maintenance standards, or other factors.

Guidance on how to develop local maintenance standards is provided in the USBM final report "Maintainability Design of Underground Mining Equipment" (1). Several definitions are provided to clarify items in the actual checklist. These include—

1. Primary maintenance zone: The zone or area from the side or the end of a mining machine inward 45 cm (18 in).

2. Secondary maintenance zone: The area from a point 45 cm (18 in) from the side or end of the machine to a point 45 cm (18 in) from the opposite side or end of the machine.

3. Tertiary maintenance point: A maintenance point outside the primary and secondary maintenance zone. An example would be a lubrication point on the end of a conveyor boom.

4. Immediately accessible: A component that can be reached, removed or repaired without having to open access covers, remove other components, or disassemble other components.

5. Maintenance point: Any point on the machine where—

- a. Two components are joined, or

- b. A component is mounted on the machine chassis, or

- c. Where hoses, cables, and lines are attached to a component.

## MAINTAINABILITY DESIGN CHECKLIST FOR UNDERGROUND COAL MINING EQUIPMENT

| <b>GENERAL MAINTENANCE REDUCTION</b>   | ADEQUATE  |    |
|--|---|----|
|  | YES   | NO |
| Hydraulic hoses, electrical cables, and water hoses are securely attached along their length to protect against abrasive wear, pinching, or other damage.                    |   |    |
| All cables and hoses are protected to minimize exposure to impact or fall of roof damage.  |   |    |
| Power feed cables enter the machine or the cable reel from the side to minimize exposure to vehicle wheels or tracks.  |   |    |
| All components, systems, and devices are located where they are protected from fall of roof damage.  |   |    |
| All exterior mounted machine features and components are protected from impact, scraping, or collision damage.   |   |    |
| Operator controls and displays are protected from impact, fall of roof damage, or inadvertent activation.  |   |    |
| Components subject to wear are designed for self-adjustment where possible.  |   |    |
| Where self-adjustment is not practical, the design provides components that can be manually adjusted for wear to minimize the need to tear down.                             |   |    |
| Design provides for a self-lubricating system for all bearings, joints, and other wear points on the machine.  |   |    |
| Design provides for bearings and seals with wear or failure monitoring capability to permit scheduling of maintenance prior to actual component failure or component damage. |   |    |
| Design provides hour meters (e.g., on conveyer circuits), volt meters and ammeters (e.g., on electric drive motors) to assist in wear assessment and maintenance management. |   |    |
| Design provides for gears, bearing, hydraulic cylinders, and other impact or load-absorbing components of sufficient size or rating to handle peak impact loads.             |   |    |
| Design provides for adequate derating for bearings, motors, and hydraulic systems to minimize overload related failures.   |   |    |
| Vehicle frame is adequately designed to prevent cracking or other fatigue-induced failures at:   |  |    |
| ▸ Hydraulic cylinder attachment points.  |   |    |
| ▸ Articulation points.   |   |    |

## MAINTAINABILITY DESIGN CHECKLIST FOR UNDERGROUND COAL MINING EQUIPMENT

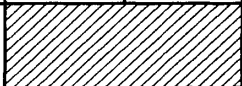
| GENERAL MAINTENANCE REDUCTION (Cont.)   | ADEQUATE  |    |
|---|---|----|
|   | YES   | NO |
| ▸ Other frame load-bearing points.  |   |    |
| ▸ Welded seams.   |   |    |
| Provides for shock and vibration isolation of critical components.  |   |    |
| Interlocks are provided to prevent vehicle from being trammed or moved with components deployed or extended that are easily damaged:                                  |  |    |
| ▸ Stab jacks.   |   |    |
| ▸ Drill booms.  |   |    |
| ▸ Tail booms.   |   |    |
| ▸ Automated temporary roof support (ATRS) components.   |   |    |
| ▸ Cutting heads.  |   |    |
| ▸ Canopies.   |   |    |
| Protective covers are over all body cavities containing components, hoses, lines, or maintenance points to prevent buildup of muck and debris.                        |   |    |
| Expanded metal grating is used for floors or other designs to prevent accumulation of water, mud, and other materials in equipment bays, crevices, and body cavities. |   |    |
| Rubber tires are protected by fenders, bumpers, or guards from collision and rib impact.  |   |    |
| Mechanical linkage systems are protected from impact and fall of roof.  |   |    |
| Roof bolter geometry is designed to prevent overelevation damage to boom lift mechanism.  |   |    |
| Disc and drum-type brake systems and components are protected from coal dust, rock, and other debris to minimize wear and damage.                                     |   |    |
| Mounting holes and brackets are designed to permit installation of functionally similar parts produced by different manufacturers.                                    |   |    |
|   |   |    |







## MAINTAINABILITY DESIGN CHECKLIST FOR UNDERGROUND COAL MINING EQUIPMENT

| <b>DESIGN FEATURES FOR ROUTINE MAINTENANCE</b>  | <b>ADEQUATE</b> |    |
|---|-----------------|----|
|   | YES             | NO |
| Routine service points are clustered in one or two service locations in the primary maintenance zone including:     |                 |    |
| ▶ Lube points.  |                 |    |
| ▶ Hydraulic reservoir tank fill points.   |                 |    |
| ▶ Hydraulic filters.  |                 |    |
| ▶ Environmental system filters.   |                 |    |
| ▶ Fuel tanks on diesel-powered equipment.   |                 |    |
| ▶ Belt or chain adjustments.  |                 |    |
| ▶ Line bleed valves.  |                 |    |
| Fluid-level indicators are provided on fluid reservoirs and in the primary maintenance zone for ease of inspection. |                 |    |
| Routine inspection points are all clearly visible and labeled including:  |                 |    |
| ▶ Relief valves.  |                 |    |
| ▶ Drain plugs.  |                 |    |
| ▶ Wear points.  |                 |    |
| ▶ Hydraulic line connections.   |                 |    |
| ▶ Personnel safety equipment.   |                 |    |
| Test points for stand-alone or built-in test equipment are located in the primary maintenance zone.                 |                 |    |
| All mechanical adjustment points are located in primary maintenance zones.  |                 |    |
| Quick connect type couplers are installed on frequently changed hydraulic lines, water hoses, and cables.           |                 |    |

## MAINTAINABILITY DESIGN CHECKLIST FOR UNDERGROUND COAL MINING EQUIPMENT

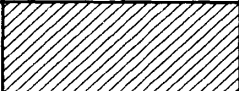
| <b>DESIGN FEATURES FOR ROUTINE MAINTENANCE<br/>(Cont.)</b>  | ADEQUATE  |    |
|---|---|----|
|   | YES   | NO |
| Quick-release fasteners are used on doors or covers for routine inspection points.  |   |    |
| Only one type of hydraulic fluid is used on the machine.  |   |    |
| Oil seals are easy replaceable types.   |   |    |
| Design reduces to a minimum the number of spare parts and components required to support maintenance:   |  |    |
| ▶ Common hoses.   |   |    |
| ▶ Connectors.   |   |    |
| ▶ Valves.   |   |    |
| ▶ Drive belts, chain, etc.  |   |    |
| ▶ Cables.   |   |    |
| ▶ Nuts and bolts.   |   |    |
| ▶ Washers.  |   |    |
| Routine service points are not located behind other components or structural members, in enclosed spaces, or in the secondary maintenance zone (e.g., more than 46 cm (18 in) from the side or the end of the machine). |   |    |
|   |   |    |



## MAINTAINABILITY DESIGN CHECKLIST FOR UNDERGROUND COAL MINING EQUIPMENT

| DESIGN FEATURES FOR TROUBLESHOOTING (Cont.)  | ADEQUATE  |    |
|--|---|----|
|  | YES   | NO |
| Manual test points are located in the primary maintenance zone for all critical systems or subsystems.                     |   |    |
| Test points are designed to eliminate or minimize the need to remove components for testing.                               |   |    |
| Locate test points in one or two locations where practical or in a single test panel.                                      |   |    |
| Test points are coded or labeled to identify recommended or acceptable pressure, temperature, or voltage ranges.           |   |    |
| Test points are labeled and are located close to the control or display they are associated with.                          |   |    |
| Built-in test capability and/or test equipment provided to monitor wear on critical bearings or other wear points such as: |  |    |
| ▶ Continuous miner cutterhead.   |   |    |
| ▶ Gathering arms.  |   |    |
| ▶ Articulation bearings on scoops.   |   |    |
| ▶ Hydraulic pumps.   |   |    |
| Test set instructions for built-in test equipment (BITE) are attached to the machine at the point of service.              |   |    |
| Automatic test equipment (ATE) sensors are provided that operate without disturbing or loading the system under test.      |   |    |
| Fail-safe design for all ATE where failure of test equipment will not cause failure of the mining machine.                 |   |    |
|  |   |    |



## MAINTAINABILITY DESIGN CHECKLIST FOR UNDERGROUND COAL MINING EQUIPMENT

| <b>DESIGN FEATURES FOR REPAIR AND REPLACEMENT<br/>(Cont.)</b>  | ADEQUATE |    |
|--|----------|----|
|  | YES      | NO |
| Design eliminates the need for special tools or jigs to perform required maintenance.  |          |    |
| All major parts used are readily available from local suppliers or vendors.  |          |    |
| All mounting bolts are directly accessible and unobstructed to permit use of required hand tools without having to remove or disassemble adjoining components. |          |    |
|  |          |    |



## MAINTAINABILITY DESIGN CHECKLIST FOR UNDERGROUND COAL MINING EQUIPMENT

| <b>VISUAL INSPECTIONS AND ACCESSIBILITY</b>   | ADEQUATE |    |
|---|----------|----|
|   | YES      | NO |
| All maintenance points should be visually accessible from the side or the end of the machine and should provide line-of-sight inspection capability.  |          |    |
| Design provides for clear and rapid visual identification of parts that may have to be replaced or repaired.  |          |    |
| Approved glass covers should be installed in all access opening covers if routine visual inspection of maintenance points are required.   |          |    |
| Access openings should be large enough to permit visual contact with the component being worked on while the work is being performed.   |          |    |
| Visual access openings should not be located on the top of machines unless the average roof height above the top of the machine is 61 cm (24 in) or more.   |          |    |
| Visual access openings should never be located under the main chassis of the machine or behind other components that may restrict visibility.   |          |    |
| For less frequently performed maintenance tasks, the maintenance point may be located behind a protective cover. The component, however, should be directly visible when the protective cover is removed. |          |    |
| Maintenance and service points should be located no further than 91 cm (36 in) from the maintainer's head at time of inspection.  |          |    |
|   |          |    |

## MAINTAINABILITY DESIGN CHECKLIST FOR UNDERGROUND COAL MINING EQUIPMENT

| DESIGN FOR PHYSICAL ACCESSIBILITY   | ADEQUATE |    |
|---|----------|----|
|   | YES      | NO |
| All components are accessible from the side or the end of the machine.  |          |    |
| All drain valves for compressor tanks, reservoirs, and sumps are accessible from the side or end of the machine.  |          |    |
| All other maintenance points are accessible from the sides or ends of the machine.  |          |    |
| All components that require repair, replacement, or adjustment every 2,000 h or less should be directly accessible (can be removed-replaced without having to remove other components) from the sides or ends of the machine. |          |    |
| For components with an expected service life of over 2,000 h, only one other component should have to be removed to access for removal or replacement (R/R).  |          |    |
| For components that must be disassembled to be repaired or inspected (e.g., bearings), no more than four R/R task steps (e.g., remove part A, remove part B, etc.) should be required to access the targeted part.            |          |    |
| All components weighing more than 23 kg (50 lb) or more should be removed from the side or the end of the machine and should not have to be lifted up and over the machine frame or other components.                         |          |    |
| Hinged or quick-release access opening covers should be used where practical with the hinges on the side or bottom so that door will remain open during maintenance.  |          |    |
| A minimum number of bolts or fasteners should be used on access covers, equipment bay doors, or other protective shielding.   |          |    |
| For components weighing more than 45 kg (100 lb), access openings and workspace should be sufficient to permit the attachment of hoisting or lifting devices.   |          |    |
| Screws, nuts, and bolts should be located to permit use of requisite hand tools to remove or replace them.  |          |    |
| Access openings should be sufficiently large to permit removal and replacement of all components contained in that area.  |          |    |
| Nonhinged access opening covers weighing more than 23 kg (50 lb) are designed with built-in handles or lifting device attachment points.  |          |    |
| All components can be removed and replaced in a straight line from their place of attachment. (Components do not have to be maneuvered around or over structural features or components.)                                     |          |    |
| Design provisions are made to support components weighing over 23 kg (50 lb) while they are being unbolted or bolted into place.  |          |    |
|   |          |    |

## MAINTAINABILITY DESIGN CHECKLIST FOR UNDERGROUND COAL MINING EQUIPMENT

| HYDRAULIC SYSTEM MAINTENANCE DESIGN   | ADEQUATE |    |
|---|----------|----|
|   | YES      | NO |
| Fluid reservoirs have adequate storage capacity to ensure uninterrupted operation between shifts.   |          |    |
| Dual in-tank or stand-alone filters are installed on each fluid system to minimize component and control valve wear.                                      |          |    |
| Hydraulic system filters are located in the primary maintenance zone and use permanent or cartridge-type filters.   |          |    |
| Hydraulic meters and gauges are located in the primary maintenance zone.  |          |    |
| Quick-disconnect-type hydraulic line connectors are used where practical.   |          |    |
| Hydraulic systems are designed to be fail safe with the system or components reverting to a safe or neutral position in event of loss of power.           |          |    |
| Hydraulic circuits are permanently labeled to identify circuit, direction of fluid flow, recommended pressure settings, and high- and low-pressure lines. |          |    |
| All hydraulic valves are labeled to positively identify the system-subsystem operated by that valve; the label should not be on the valve itself.         |          |    |
| Design uses seals that are visible after installation to ensure that they are not inadvertently left out during maintenance.                              |          |    |
| Design uses armor-coated flex hoses where hoses are subject to abrasive wear or impact damage.  |          |    |
| Design provides for automatic bleeding of major hydraulic system(s).  |          |    |
| Physically incompatible connectors are specified where there is a danger of mismatching connectors from adjoining systems.                                |          |    |
| Design provides metal shielding to protect electrical and other sensitive equipment in the event of hydraulic fluid leak.                                 |          |    |
| Design prevents the accumulation of hydraulic fluids in the event of leaks or hose breaks.  |          |    |
| Design provides for hydraulic system drains at the lowest physical level in the system.   |          |    |
| Hydraulic system fittings and valves are staggered to provide improved access to each system's connectors.  |          |    |
|   |          |    |

## MAINTAINABILITY DESIGN CHECKLIST FOR UNDERGROUND COAL MINING EQUIPMENT

| <b>MECHANICAL SYSTEM MAINTENANCE DESIGN</b>  | ADEQUATE  |    |
|--|---|----|
|  | YES   | NO |
| Design provides for minimum manual adjustment of all mechanical systems, except to correct for wear.   |   |    |
| Self-adjustment designs are incorporated where practical.  |   |    |
| Adjustments that cannot be designed out should:  |  |    |
| ▸ Be completed without the requirement to disassemble the unit.  |   |    |
| ▸ Be reduced to the minimum number of steps possible to complete.  |   |    |
| ▸ Not require removal or replacement (R/R) of other components to complete.  |   |    |
| ▸ Be incorporated into other required maintenance on the same component.   |   |    |
| ▸ Incorporate range limits to prevent over-adjustment damage.  |   |    |
| Design precludes the need for special tools or hardware to install, adjust, or align mechanical components.  |   |    |
| Components and mechanical interfaces are designed with the minimum number of pivots, bearing surfaces, and other moving part wear points to minimize maintenance requirements. |   |    |
| Mechanical system locks or locking devices are incorporated wherever mechanical locking is required for maintenance.   |   |    |
| Design avoids the use of through bolts for installation or assembly where the nuts are not accessible to the maintainer.   |   |    |
| Design locates high-failure-rate components outboard in the primary maintenance zone.  |   |    |
| Design provides for coverings or boots for exposed connectors, universal joints, and other interacting mechanical parts to protect them from mud, coal dust, and other debris. |   |    |
|  |   |    |

## MAINTAINABILITY DESIGN CHECKLIST FOR UNDERGROUND COAL MINING EQUIPMENT

| ELECTRICAL SYSTEM MAINTENANCE DESIGN   | ADEQUATE |    |
|--|----------|----|
|  | YES      | NO |
| Design provides overload or other electrical protective devices for all major electrical circuits, each of which is equipped with a "kickout" indicator light for easy troubleshooting on:   |          |    |
| ▶ Drive, conveyor, cutterhead, and gathering arm motors.   |          |    |
| ▶ Lighting.  |          |    |
| ▶ Electric power takeoffs.   |          |    |
| Design routes all electrical cables on machine to avoid damage from abrasion, pinching, or cutting.  |          |    |
| All electrical cabling is routed to permit easy removal and replacement. Cabling is not routed under machine chassis, in the center of boom arms, or in other difficult-to-access locations. |          |    |
| Electrical connectors are isolated from hydraulic fluid leaks, fuels, water, and other liquids.  |          |    |
| Quick-disconnect-type electrical connectors are used where possible.   |          |    |
| All electrical equipment cabinets are equipped with interlock that terminates power to the unit when the access cover is removed.  |          |    |
| A manual override is provided for all cabinets equipped with shutoff interlock.  |          |    |
| Breakers and other overload protective devices are in a central location in the primary maintenance zone.  |          |    |
| Electrical connector pin patterns are coded to permit connecting cables only to the appropriate receptacle.  |          |    |
| Uses electrical plugs in which the alignment pins extend beyond the electrical pins.   |          |    |
| Design makes receptacles "hot" or "cold."  |          |    |
| Uses contact pins no larger than 30 cm (12 in) to resist being bent upon insertion and withdrawal of the connector.  |          |    |
| Design uses right-angle plugs to avoid sharp bends in the electrical cable.  |          |    |
|  |          |    |

## MAINTAINABILITY DESIGN CHECKLIST FOR UNDERGROUND COAL MINING EQUIPMENT

| <b>PERSONNEL PROTECTIVE EQUIPMENT MAINTENANCE</b>  | ADEQUATE |    |
|--|----------|----|
|  | YES      | NO |
| Personnel protective equipment is designed and located to facilitate inspection, repair, and replacement of the following systems: |          |    |
| ▶ Dust control.  |          |    |
| ▶ Methane monitoring.  |          |    |
| ▶ Operator protective canopy (as required).  |          |    |
| ▶ Operator panic bars.   |          |    |
| ▶ Emergency power cutoff devices.  |          |    |
|  |          |    |

## MAINTAINABILITY DESIGN CHECKLIST FOR UNDERGROUND COAL MINING EQUIPMENT

| <b>DESIGN FOR MECHANICAL SAFETY</b>  | <b>ADEQUATE</b> |           |
|--|-----------------|-----------|
|  | <b>YES</b>      | <b>NO</b> |
| Protective guards are provided on or around all moving mechanical parts adjoining to where maintenance personnel will be working.  |                 |           |
| Mechanical lockout devices are provided where maintenance must be performed at location that exposes maintainer to moving components (e.g., under a cutterhead).             |                 |           |
| Design prevents components from slipping or falling as they are being unbolted for repair or replacement.  |                 |           |
| Mechanical components are located to prevent maintainer from being exposed to energized equipment, hazardous fumes, hot surfaces, or other hazards during repair operations. |                 |           |
| Mechanical components that require the use of heavy springs are designed so that the springs cannot inadvertently dislodge, causing damage or personnel injury.              |                 |           |
| Design provides for warning plates where mechanical assemblies, linkages, or components are under high strain or loading.  |                 |           |
| Design routes hot exhaust pipes away from locations where routine maintenance will be performed.   |                 |           |
| Design prevents failure of high-stress-loaded component from damaging other components or injuring personnel.  |                 |           |
|  |                 |           |

## MAINTAINABILITY DESIGN CHECKLIST FOR UNDERGROUND COAL MINING EQUIPMENT

| <b>STORAGE BATTERY MAINTENANCE</b>   | ADEQUATE                 |                          |
|--|--------------------------|--------------------------|
|  | YES                      | NO                       |
| Design isolates routine machine maintenance points from battery fumes.                                       | <input type="checkbox"/> | <input type="checkbox"/> |
| Design prevents leaking battery acid from accumulating in equipment compartments or operator station.        | <input type="checkbox"/> | <input type="checkbox"/> |
| Batteries are installed in a location that permits use of overhead lifting device to remove or replace them. | <input type="checkbox"/> | <input type="checkbox"/> |
|  | <input type="checkbox"/> | <input type="checkbox"/> |



# INEXPENSIVE, EASY TO CONSTRUCT MATERIALS-HANDLING DEVICES FOR UNDERGROUND MINES

By Richard L. Unger<sup>1</sup> and Kirk Conway<sup>2</sup>

## ABSTRACT

The U.S. Bureau of Mines (USBM) has developed and tested designs for six materials-handling devices for use in underground mines to reduce materials-handling injuries. Particular attention was focused on making the designs practical, low cost, and easily fabricated to be broadly applicable in underground operations. Where possible, the designs were simplified so that off-the-shelf components could be used to permit fabrication by mine personnel on

site. The six devices include scoop-mounted lift boom, swing-arm boom, heavy component lift-transport, mine mud cart, container-work station cart, and timber car.

This paper presents a brief discussion of that work and the six devices. It is intended for mine operators who wish to make use of the design concepts to manufacture similar devices for use in their mines.

## INTRODUCTION

Manual materials handling represents a critical and persistent source of personnel injuries in underground coal mining operations. On an annual basis, such injuries represent the largest category of nonfatal, lost-time injuries, accounting for 35% of all lost-time injuries in 1983 and 1984, according to an analysis of U.S. Mine Safety and Health Administration (MSHA) data. Approximately 26% of all injuries related to manual materials handling are associated with the performance of mine maintenance or equipment maintenance tasks (fig. 1).

In the mid-1980's, as part of its program to improve health and safety conditions in mines, the USBM conducted a research program that addressed the materials-handling problems of mine maintenance and equipment maintenance. During the course of the project, a detailed analysis of mine- and machine-related tasks was completed and sources of injuries were identified. Concepts for simple materials-handling devices that could replace manual handling were then developed and evaluated. Six of these devices were fabricated and delivered to operational underground coal mines for testing and

evaluation. Complete plans for the devices are available in USBM Information Circular (IC) 9212.<sup>3</sup>

<sup>3</sup>Conway, E. J., and R. L. Unger. Material Handling Devices for Underground Mines. BuMines IC 9212, 1989, 48 pp.



**Figure 1.—Most materials handling is done manually in underground coal mines, which is part of the reason it is the leading cause of injuries year after year.**

<sup>1</sup>Civil engineer, Pittsburgh Research Center, U.S. Bureau of Mines, Pittsburgh, PA.

<sup>2</sup>Senior staff scientist, VRC Corp., Monterey, CA.

## SUMMARY OF DESIGN RATIONALE

The work described in USBM IC 9212 specifically addressed materials-handling tasks related to mine maintenance and equipment maintenance performed in underground coal mines. Surface materials-handling tasks and the transporting of supplies or materials from the surface to the operating section were outside the scope of this effort.

### MINE AND EQUIPMENT MAINTENANCE

Representative mine maintenance tasks included—

1. Installation or removal of ventilation, electrical, communications, or compressed-air systems.
2. Installation of timbers, cribbing, and other supplemental materials used in roof or rib control.
3. Track installation, repair, and retrieval.
4. Rock dusting, installation of air-control screens, and electrical wiring installation of warning or other systems.

Typical machine maintenance tasks falling within the scope of this project included—

1. Removal or replacement of belt drives, head, pumps, drive motors, and other major machine parts on stationary equipment.
2. Assembly, installation, and repair to mine equipment, including mobile face equipment.
3. Routine servicing of mining equipment.

All underground coal mine seam heights were included in this study. However, emphasis was placed on midseam to lower seam coal mines (under 147-cm (58-in) seam height) because preliminary data suggested that the highest risks of manual materials-handling injuries were to be found in those seam heights. The study included a review of relevant materials-handling literature and past USBM programs, visits to six operating coal mines, and an extensive analysis of MSHA's accident database.

The mine maintenance and equipment maintenance tasks investigated involved, by their very nature, the manual handling of supplies and equipment components. Individual modules of items handled might range in weight from a few to several thousand kilograms. Because of the operational constraints in underground coal mines, these materials and components often have to be manually moved from the supply dropoff point to the place where they will actually be used or installed.

Components used in equipment maintenance are typically hoisted onto a railroad car, scoop bucket, or maintenance jeep on the surface. They are then transported to the section where the disabled machine is located. At that point, they are manually lifted off the rail car or jeep or

ejected out of the scoop bucket and manually carried to the installation position. Occasionally, hoists or come-alongs are attached to roof bolts to aid in this process. Replaced components are then manually loaded into the transport vehicle for shipment to the surface.

Mine maintenance materials (e.g., timbers, rock dust bags, roof bolts, etc.) are typically loaded in bales or via pallets onto railcars or into scoop buckets for shipment to or near the working section. At the end of the rail line, the bales or pallets are broken down for manual loading into scoops or onto other transport vehicles for delivery to work locations. (One mine visited had rubber-tire-equipped railcars that could be detached at the end of the rail line and towed by battery-powered vehicle to the work locations or section supply areas.) Once the materials are dumped near the work location, miners manually carry them to the maintenance point for use. These maintenance personnel may lift materials weighing 23 to 226 kg (50 to 500 lb) continually on a daily basis. They handle materials (sections of rail or steel arches) weighing 454 kg (1,000 lb) or more on a monthly or more frequent basis.

Analyses of materials-handling injuries in the six mines visited indicated that—

1. Thirty-nine percent of all mine maintenance and 35% of all machine maintenance injuries involved the lower back.
2. Forty-five percent of all mine and 39% of all machine maintenance accidents were the result of overexertion.
3. Sixty-eight percent of mine maintenance injuries involved handling timbers, posts, caps, and cribbing materials, while 32% of the machine-related accidents involved handling metal machine components.

### MECHANIZATION REQUIREMENTS

The design implications of these and other findings revealed during studies of materials-handling tasks related to mine and equipment maintenance can be summarized by the following mechanization needs:

1. Devices to lift or lower and rotate machine components weighing up to 1,361 kg (3,000 lb) for removal from and replacement on mining equipment.
2. Devices to lift or lower components of up to 226 kg (500 lb) in and out of scoops, off railcars, and on or off other mobile vehicles.
3. Carts or other devices to transport small quantities of materials weighing up to 226 kg (500 lb) from storage areas or railheads to working sections.
4. A device to raise and support crossbeams for temporary roof support while permanent roof supports are installed.

Six materials-handling devices were developed to fulfill these needs. Particular attention was focused on making the designs practical, low cost, and easily fabricated so as to be broadly applicable in underground operations. Where possible, the designs were simplified and off-the-shelf components used to permit fabrication of the devices by mine personnel on site.

The devices discussed in this paper are not intended to be final designs. Rather, they are working prototypes that have been field evaluated and are presented herein in the hopes of stimulating other innovative designs on the part of mine personnel.

## PROTOTYPE MATERIALS-HANDLING DEVICES

### SCOOP-MOUNTED LIFT BOOM

One of the major identified needs was for a simple boom device to lift and transport components weighing up to 1,361 kg (3,000 lb) in the underground environment. The device had to be mounted on a powered mobile machine and installed and removed quickly to minimize production down time for the machine. This tool would be used for transporting and maneuvering heavy machine components such as a continuous miner head.

A quick-mount-dismount lift boom device was developed for installation on the front of a small scoop with its bucket removed (figs. 2-3).

The design features of the scoop-mounted lift boom include—

1. A 1,361-kg (3,000-lb) lift capacity.
2. Manual or powered lift capability.
3. Installation and removal in 5 min or less.
4. Ready storage in working section or on mobile machinery.

Four attachment points secure the lift boom to the scoop lift mechanism by means of four pins. The pins correspond in size and location to the pins used to secure the scoop bucket. The overhead design of the lift boom permits lifting or lowering of components being handled. The bucket tilt mechanism provides up and down maneuvering of the components, while the scoop's normal steering permits lateral and forward and reverse maneuvering.

### SWING-ARM BOOM

Accident and biomechanical analyses suggested the need for a simple swivel crane or boom device to lift components on and off transport vehicles and to assist in maneuvering heavy machine components in confined spaces.

The six devices include—

1. Scoop-mounted lift boom.
2. Swing-arm boom.
3. Heavy component lift-transport.
4. Mine mud car.
5. Container-work station vehicle.
6. Timber car.

Functions performed by, and design specifications for, each of these devices are discussed in the following section.

To address these requirements, a lightweight, removable, storable lift boom was designed (figs. 4-5). This boom can be installed at various locations on maintenance carts or on mining machines themselves. The height of the boom can be varied by quickly changing the boom leg. The inexpensive mounts can be permanently welded at various locations on the machine frame and are designed to

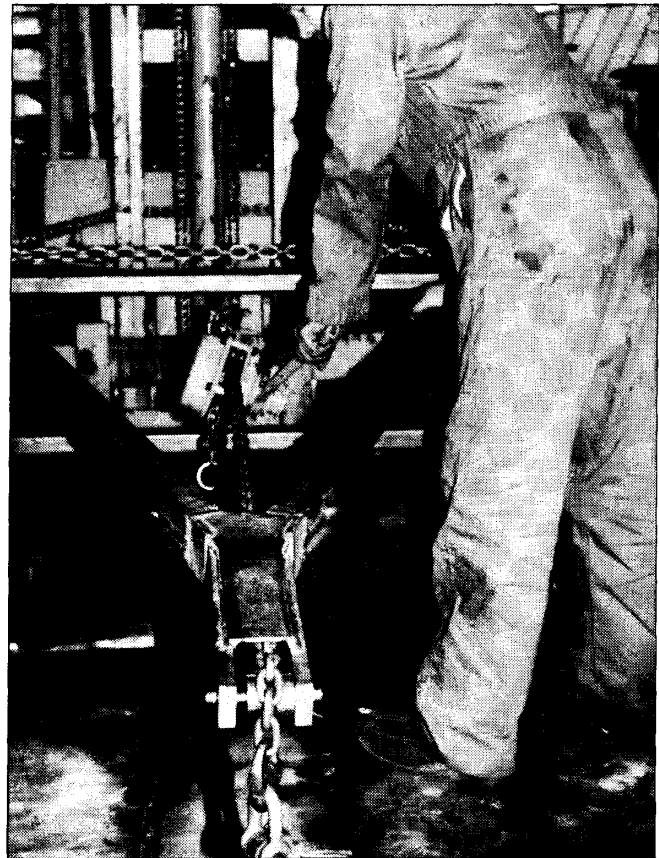

Figure 2.—Testing scoop-mounted lift boom at Pittsburgh Research Center.

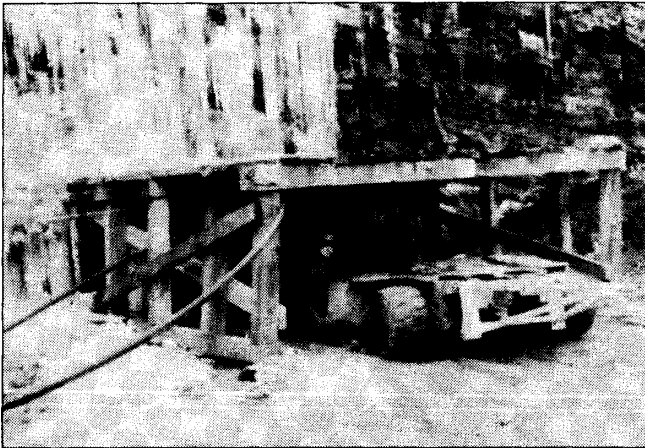

Figure 3.—Scoop-mounted lift boom during surface tests.

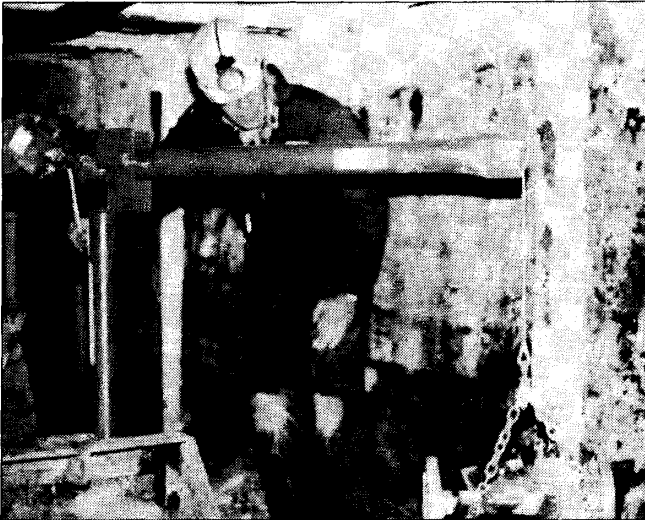

Figure 4.—Machine-mounted swivel crane during underground tests.

resist damage during normal machine operation. Two or more quick mounts can be installed on the same machine to permit access to all machine locations.

Design features of the swing-arm boom include—

1. Load capacity of 227 kg (500 lb).
2. Boom height range from 61 to 173 cm (24 to 68 in), depending on leg length.
3. Arm radius of 61 to 122 cm (24 to 48 in).
4. Mounting and stowing without tools.
5. Light weight for carrying by one person.

#### HEAVY COMPONENT LIFT-TRANSPORT

Another identified need was for a floor-type maintenance jack that could be used to lift heavy machine

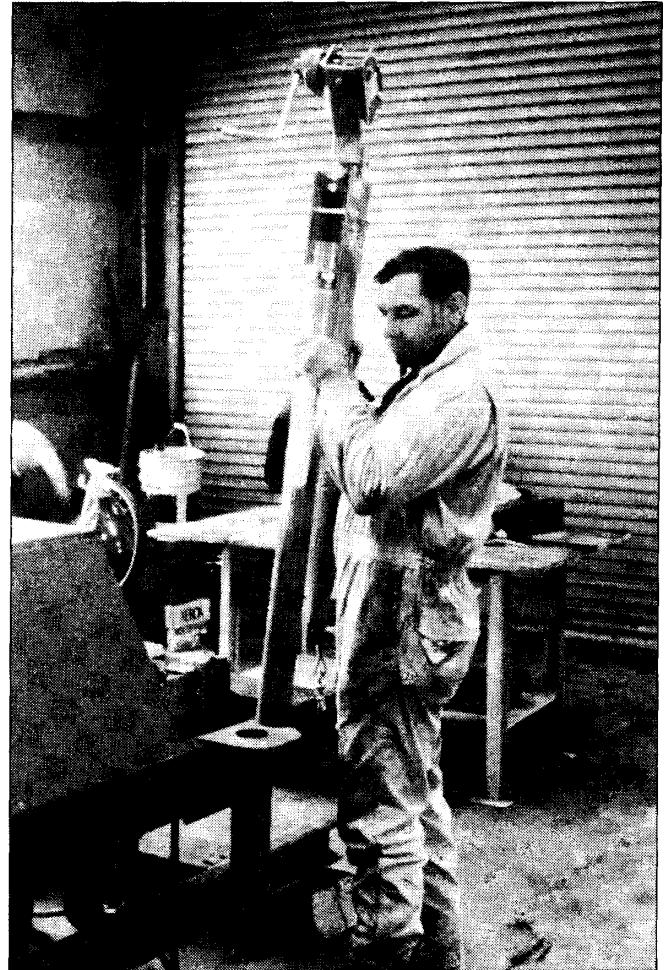
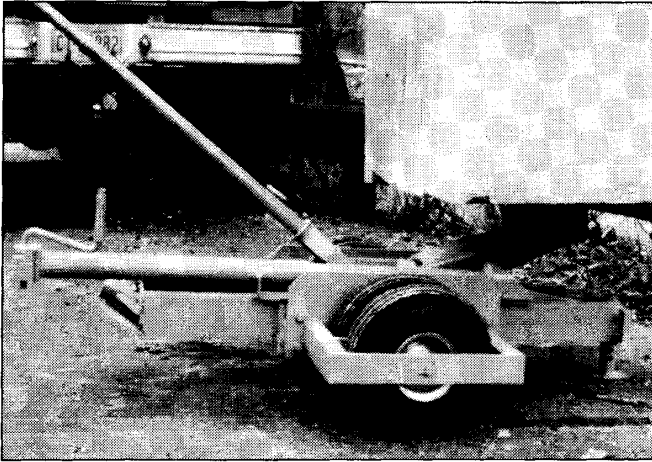

Figure 5.—Crane is easily mounted in its removable base.

components from the bottom, transport them over short distances, and lift them into position for installation. Saddles on the lift point could be designed to permit additional maneuvering of the component during actual installation. This type of device could be used, for example, to install drive motors under the nonremovable fenders in shuttle cars.

The heavy component lift-transport prototype is shown in figures 6 and 7. The device utilizes a standard hydraulic floor jack to provide the lift mechanism. The jack head itself is tiltable and rotatable to permit close-in maneuvering. The jack mechanism travels along the device frame by means of a sump drive mechanism. This motion permits forward-backward movement of handled components and balancing of components over the lift-transport device wheels during travel. The long handle permits the use leverage by which to maneuver loads up and down or sideways, as required. Dual tires or oversized balloon tires increase the device's stability and permit easy movement over uneven floors.



**Figure 6.—Heavy component lift-transport during testing with 680-kg (1,500-lb) concrete block.**

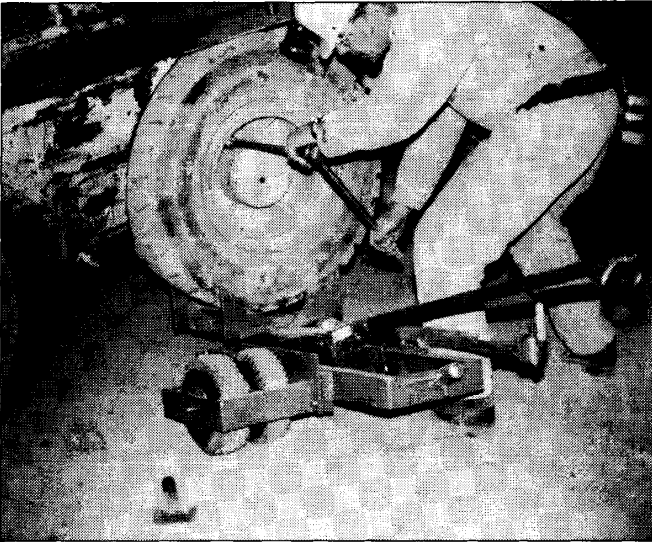

**Figure 7.—Tire-changing attachment eliminates manual handling of heavy wheels during replacement.**

The design features of the heavy component lift-transport include—

1. Up to 454-kg (1,000-lb) lift capacity.
2. Balloon tires for ease of transporting manually.
3. A standard automotive floor jack for the lift mechanism.
4. Ability to lift and maneuver a heavy component as it is being removed or replaced on a mining machine.
5. Jack head that can be trammed forward or back on the frame for close-in maneuvering or for load balancing.

## MINE MUD CART

One of the basic problems faced by all miners is that of moving machine components or supplies such as concrete blocks from the supply storage area to the point of use. If a powered vehicle is not available, the task must be accomplished manually. The intent of this concept was to design a small, manually pulled cart that could transport up to 408 kg (900 lb) of materials over a short distance.

The mine mud cart has the following design features:

1. Narrow width to permit passage by a parked mining machine.
2. Tandem design to prevent tipover if one unit is loaded and the second is empty.
3. Balloon tires for transit through mud or water and over mine floors.
4. Handle designed for pulling by one or two people.

Figure 8 illustrates a tandem cart concept using eight wheels. The vehicle can also be fabricated as a single cart.

## CONTAINER-WORK STATION VEHICLE

Hand tools and supplies required to perform most maintenance tasks in a section can be mounted on a transportable container. This concept is for a device that allows a single manually powered mechanism to lift and transport such containers (figs. 9-10). There are many uses for the containers themselves, such as tool station, lubrication module, rock dust unit, fire and safety equipment storage, repair work station, and cable-splicing module.

To move the container around the working section, the transporter is positioned around the container and a lift mechanism raises it off the floor and positions the load slightly ahead of the axle. The load is carried by the wheels while the operator controls motion by pulling, steering, and balancing the unit on its axle.

Design features of the container-work station include—

1. Rapidly interchangeable containers that can be picked up or dropped off as required.
2. Containers that can be used as secured storage units when dismantled from the vehicle.
3. Up to 454-kg (1,000-lb) load capacity.
4. Adjustable ground clearance.
5. Balloon-type tires for easy transporting on unimproved mine floor.
6. A tow bar that can be adapted for towing behind utility vehicles.

**TIMBER CAR**

One of the most hazardous materials-handling tasks in underground mining is that of installing crossbeams for roof support. A need was identified for a mechanism to lift beams weighing up to 227 kg (500 lb) to the roof, where they could be held in place until permanent supports could be installed (figs. 11-12). The device shown in the figures utilizes a modified hydraulic floor jack to provide the lift. The jack mechanism is moved manually along a track down the center of the car. This forward-backward movement permits easy positioning of the load. In addition, the jack head rotates to ease positioning of extra-long members.

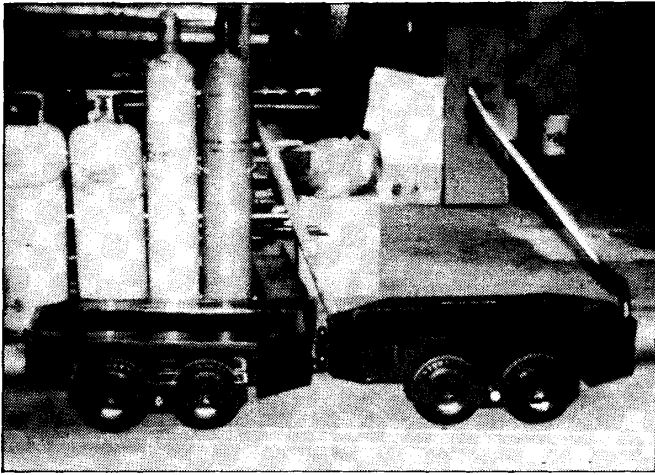

**Figure 8.—Mine mud cart.**



**Figure 9.—Container-work station vehicle.**

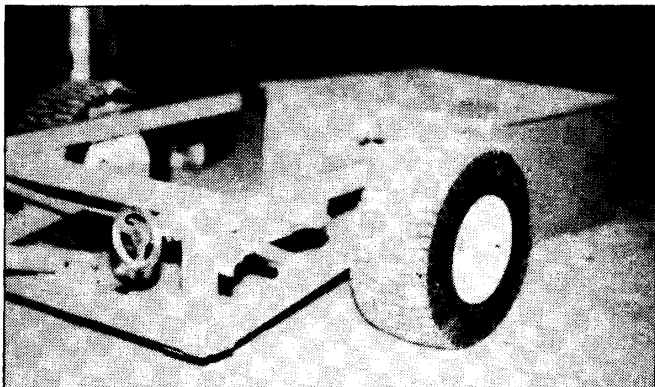

**Figure 10.—Container is easily removed from frame of vehicle. Containers with specialized functions may then be attached.**

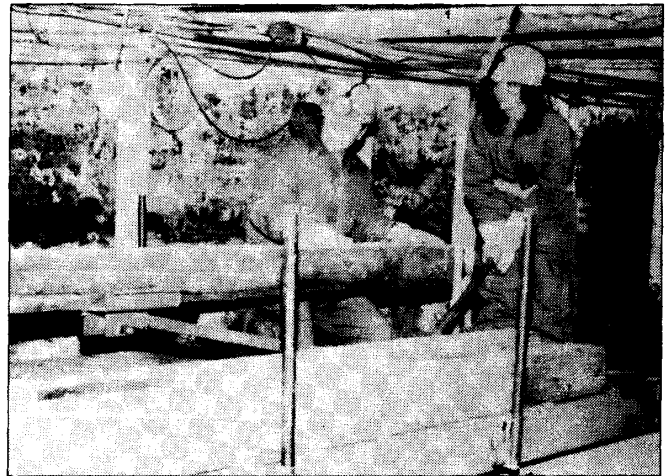

**Figure 11.—Timber car during underground tests at Pittsburgh Research Center's safety research coal mine.**



**Figure 12.—Miners using timber car to raise 39-kg (85-lb) rail for roof support in an eastern Ohio coal mine.**



Design features of the timber car include—

1. Up to 227-kg (500-lb) lift capacity with a 152-cm (60-in) lift height (suitable for low- to medium-seam mines).
2. Mounting on a low-profile flatcar, which serves double duty as a 36,287-kg (40-st) capacity supply car.

3. A modified automotive floor jack for the lift mechanism.

4. Jack that can be maneuvered forward or back in its track for close-in maneuvering.

## CONCLUSIONS AND RECOMMENDATIONS

On-site visits, task analyses, and interviews suggest that the majority of the risk exposure associated with materials handling in underground coal mines results from the lack of properly designed and easily accessible materials-handling tools, devices, and vehicles. Mine personnel traditionally rely on a "couple of extra hands" or on crowbars, come-alongs, and other makeshift tools to handle even the largest components of mining machinery. Similarly, due to the lack of appropriate tools, carts, and other handling devices, mine personnel manually move timbers, posts, beams, and other heavy materials on a continual basis. In most instances, tools are simply not available for these heavy lifting, transporting, and positioning tasks.

These investigations also revealed that what is needed is not another complex, powered vehicle designed to perform any and all maintenance jobs. Rather, what is required is a series of simple, task-specific tools, aids, and devices to be housed and used in the working sections and maintenance areas. Mine personnel tend not to wait 30 to 60 min while a special vehicle or tool is brought in from another area of the mine. The materials-handling hardware should be relatively easy to fabricate and should, where possible, utilize off-the-shelf components. The hardware should be relatively inexpensive and designed for fabrication in mine shops. The prototypes of six such devices that were developed and tested by the USBM are described in this paper.

There appears to be a sincere interest on the part of mine management and safety and production personnel in reducing injuries related to materials handling. There is also a need for exposure to new ideas, products, and materials-handling mechanization concepts to assist mine personnel in identifying their own unique handling requirements and developing appropriate mechanical solutions to these problems. The concepts presented here were designed to stimulate the development of other mechanization concepts to address mine-specific materials-handling problems.

Three major recommendations are suggested with respect to development of materials-handling devices:

1. *Systems Approach to Materials Handling.*—Many larger mines have developed so-called systems for moving huge quantities of supplies and materials from surface storage areas to in-mine drop points or supply depots. These systems, however, have many missing elements and

built-in problems. For example, pallets are utilized to load quantities of 41-kg (90-lb) cement blocks or 45-kg (100-lb) bags of rock dust from the storage onto the supply train. Forklifts or hoists may be used to offload the pallets at the dropoff points. However, personnel must manually load these supplies onto battery-powered vehicles or physically lug them to the point of use. This systems-approach thinking has failed to account for the fact that the blocks still weigh 41 kg (90 lb) and the bags 45 kg (100 lb) apiece when they get into the mine. These loads are too heavy for personnel working in confined workspaces and on unimproved mine floors. If a systems approach is to be used, it should start with the end user or task and work backward from there.

2. *Task-Specific Tools.*—As in any industry, the design of special tools to perform specific tasks is often overlooked. In underground mining, few if any tools or devices have been developed to cope with specific materials-handling tasks. Exposure to high-risk tasks could be substantially reduced if appropriate task-specific tools were available. For example, the transporting of materials through a 91- by 91-cm (3- by 3-ft) door requires the miner to lift a 23- to 45-kg (50- to 100-lb) (or heavier) object, rotate his or her body, and have the object through the door opening. Exposure to overexertion-type injuries is very high. If a simple slide or materials conveyor was available, the miner could simply pass the material through the opening. Similar aids and mechanical tools are required for handling rail sections, timbers, posts, cribbing materials, etc.

3. *New Technologies.* The search for new technologies is an ongoing process in any industry. In underground mining, however, it is even more important since so little completely new technology has been introduced to this sector. With respect to materials-handling, this search should focus on new, low-cost, reduced-weight materials for mine maintenance and safety applications. It should address improved designs and packaging for manual handling in operational environments. It should cover improved methods of installation and maintenance of the mine and the mining equipment. It should focus on ways of reducing mine maintenance (e.g., cleaning up along belt lines) and machine maintenance (e.g., autolubing systems). It should attempt to replace muscle power (particularly back muscles) with mechanical or hydraulic power.