

A mining research contract report
FEBRUARY 1983

EVALUATION OF THE BLACK RIVER MINE TELECOMMUNICATION SYSTEM

Contract J0318074
Atlantic Research Corporation

The views and conclusions contained in this document are those of the authors and should not be interpreted as necessarily representing the official policies or recommendations of the Interior Department's Bureau of Mines or of the U.S. Government.

BUREAU OF MINES
UNITED STATES DEPARTMENT OF THE INTERIOR



The views and conclusions contained in this document are those of the authors and should not be interpreted as necessarily representing the official policies or recommendations of the Interior Department's Bureau of Mines of of the U.S. Government.

REPORT DOCUMENTATION PAGE	1. REPORT NO.	2.	3. Recipient's Accession No.
4. Title and Subtitle Evaluation of the Black River Mine Telecommunication System			5. Report Date February 1983
7. Author(s) Dana T. Updyke and Howard C. Turnage			6.
9. Performing Organization Name and Address Atlantic Research Corporation 5390 Cherokee Avenue Alexandria, Virginia 22314			8. Performing Organization Report No.
12. Sponsoring Organization Name and Address United States Department of the Interior Bureau of Mines, Pittsburgh Research Center Cochran's Mill Road, P.O. Box 18070 Pittsburgh, Pennsylvania			10. Project/Task/Work Unit No.
			11. Contract(G) or Grant(G) No. (C) J0318974 (G)
			13. Type of Report & Period Covered Final Report
15. Supplementary Notes Bureau of Mines Contract Manager: James C. Cawley			14.
16. Abstract (Limit 300 words) <p>An evaluation was made of one of several improved underground communication systems sponsored by the U.S. Bureau of Mines. The system evaluated was installed in a typical metal/non-metal room and pillar mine and utilized UHF repeaters connected to a unique distributed antenna and passive reflector system which provided mine-wide communications. A microprocessor controlled data collection system was assembled and installed for the evaluation. Data consisting principally of times and durations of messages and identities of the originating transceivers was collected between February and August of 1982 (6 mos.). Analysis of the data shows that the principal benefits are reduction in time required for unscheduled maintenance and repair, enhancement of safety, and better coordination of production activities. A cost benefit analysis shows a net benefit over cost, although it is also concluded that the capacity of the system is greater than can be justified by current activity in the mine.</p>			
17. Document Analysis a. Descriptors radio communication, radio relay systems, data acquisition			
b. Identifiers/Open-Ended Terms mine communication, underground communication			
c. COSATI Field/Group 17/02.1, 14/02			
18. Availability Statement		19. Security Class (This Report) Unclassified	21. No. of Pages 104
		20. Security Class (This Page) Unclassified	22. Price

FOREWORD

This report was prepared by Atlantic Research Corporation, Alexandria, Virginia under USBM contract number J0318074. It was administered under the technical direction of the Bureau of Mines with James C. Cawley acting as Technical Project Officer. Joseph A Gilchrist was the contract administrator for the Bureau of Mines. This report is a summary of the work completed under this contract during the period September 1981 to December 1982. This report was submitted by the authors in December 1982.

TABLE OF CONTENTS

		<u>Page</u>
1.0	EXECUTIVE SUMMARY	7
2.0	DESCRIPTION OF THE BLACK RIVER MINE TELECOMMUNICATION SYSTEM	13
3.0	DATA COLLECTION SYSTEM	18
	3.1 DCS Hardware Description	18
	3.2 Modat Data	19
	3.3 Systems Status Channels	23
4.0	DATA COLLECTION RESULTS	27
5.0	CONCLUSIONS RELATIVE TO SYSTEM UTILIZATION	41
	5.1 Telecommunications Needs of the Mine	41
	5.1.1 Unscheduled Maintenance and Repair	41
	5.1.2 Safety	45
	5.1.3 Supervision and Coordination of Production	46
	5.2 How the System Fulfills the Needs	46
	5.3 System Alterations	41
	5.4 How the Mine Utilizes the System	46
	5.5 How Utilization Could Be Improved	50
	5.6 Who Uses the Telecommunications System	50
	5.7 Cost Benefit	51
	5.8 How the System Configuration Compares With Other Methods	52
	5.9 Radio Traffic Histograms	52
6.0	COST BENEFIT	53
	6.1 Mine Revenue	53
	6.2 Loss in Revenue From Production Stoppage	53
	6.3 Savings in Supervision and Coordination, Production	53
	6.4 Cost of the Radio System	54
	6.5 Benefits vs Costs	54
7.0	COMPARISON WITH OTHER METHODS OF MEETING THE MINE'S NEEDS	56
	7.1 Leaky Feeder	56
	7.2 MF Reradiation Systems	57

8.0	RECOMMENDATIONS	58
	8.1 Utilization of Truck Dump-Bed Data	58
	8.2 Dispatching and Operating Procedures	59
	8.3 Elimination of Channel #3	59
	8.4 Magazine Entry Records	60
	REFERENCES	61
	APPENDIX A HISTOGRAPHS	62

1.0 EXECUTIVE SUMMARY

This document is a final report on the evaluation of the telecommunications system installed by the U.S. Bureau of Mines at the Black River Mine, Butler, Kentucky. The telecommunications system is one of several sponsored by the Bureau of Mines as part of a project to demonstrate improved underground communications in metal/non-metal mines. Previous demonstrations have included the use of off-the-shelf equipment to provide leaky feeder communications in a block caving iron mine(1), and the demonstration of an EPABX with subscriber carrier equipment in a deep-vein silver mine(2).

The Black River Mine was selected as a typical metal/non-metal room and pillar mine. It is nearly 4000 feet in diameter, 650 feet deep, and has essentially straight crosscuts approximately 30 feet wide and 24 to 40 feet high with pillars approximately 35 feet square. Entry is through a 2,200 foot slope by means of a single drum, hoist-powered flat car and enclosed man carrier. The emergency exit is through a hoist-powered capsule in a 6 foot diameter, 650 foot vertical air shaft. Rubber tired, diesel powered mine vehicles travel along designated haulage and travel roads from the active faces on the mine's perimeter to two rock crushers, the shop area, and the base of the slope.

The mine is equipped with a UHF, passive reflector distributed antenna, underground radio system installed between August 1978 and January 1981. The object sought with this system was to demonstrate in an underground room and pillar limestone mine a mine-wide communications and monitoring system that fulfills the communications needs of that type of mine. The objective of the project covered by this report was to carry out an evaluation of the Black River Mine telecommunication system and to prepare a report answering the following questions:

1. What are the telecommunications needs of this mine?
2. How does this system fulfill those needs?
3. What system alterations would better meet those needs?
4. How does the mine utilize the current system?
5. How could system utilization be improved?
6. Who uses (or doesn't use) the telecommunications system?
7. Of what cost/benefit is the telecommunications system to the mine? Discuss specific benefits and costs.

8. How does this system configuration compare against other methods of meeting the mine's needs (leaky feeder, for example) in terms of:
 - a. Technical feasibility?
 - b. Cost?
 - c. Reliability?
 - d. Cost/benefit?

9. How does the mine radio traffic look on a histogrammic basis?

The project covered by this report was begun in September, 1981. A computer controlled data collection system (DCS) was installed and placed in operation of February 26, 1982. Except for occasional outages, some lasting for several days, automatic data collection continued until August 27, 1982. The data collected included date-time information (start and finish) on all radio transmissions, transmitter identifications, and some limited status information ("PTT-normal", "PTT-emergency", dump truck "bed-up" and "bed-down"). Additional data, such as maintenance records and information on mine operations, was collected manually.

The quality of the automatically collected data was not as good as had been hoped for. The bed-up/bed-down function was inoperative during most of the data collection period. Further, the tendency of the users to take radios other than the ones assigned to them obscured to some extent the attempt to associate ID numbers with particular job functions. Another factor affecting the analysis was that the mine was operating at considerably less than full capacity during the evaluation period. Radio usage was therefore undoubtedly less than it might have been under other circumstances.

1.1 The Data Collection System

Two types of data were collected and stored by the DCS. Hardware data was automatically extracted from the radio system hardware through direct interface. Maintenance data was entered into the DCS by the on-site maintenance contractor. Management and production data required from the mine's management was collected and correlated by hand.

The operation of the DCS was as follows:

1. The DCS kept a real time clock and a month/day date as a background operation. Time resolution was a minimum of ten millisecond intervals.

2. The SYSTEM and MODAT channels were asynchronously monitored for changes in hardware status and incoming MODAT data through the use of vectored interrupts.

3. These data elements were time-tagged and placed onto a mass storage device.

4. By the use of a dial-up communications modem, this data was down loaded into the data processing facilities at ARC in Alexandria, VA for compression and processing.

5. When appropriate, manual data collection programs were run in the background to accept and store maintenance data.

The DCS controller software was written entirely in fast, efficient assembly language. The entire DCS was operated from uninterrupted power which was available on site and used to power the telecommunications system.

1.2 The Data Collected

Full time data collection began on March 1, 1982, and continued through August 27, 1982. Data was collected for each day on which activity occurred, including Saturdays, Sundays and holidays. However, little use of the radio was made on other than regular Monday through Friday work days, so that weekend traffic was of no great significance. From the data, daily records of channel occupancy in seconds were derived for each one-hour time block during the day, transactions for each one-hour time block during the day, and daily activity counts for each MODAT equipped radio. Valid channel occupancy records were obtained for 111 days and daily activity counts for 116 days out of a total of 127 work days (i.e., 26 five-day weeks less three holidays) included in the data collection period. Data collection system malfunctions accounted for the loss of records from Saturday, April 17 through Wednesday, April 21, and from Tuesday, May 18 through Monday, May 24. During the week preceding the second system outage, a failing clock module resulted in unrealistically high occupancy levels (i.e., occupancies greater than 3600 seconds in a one hour period). The occupancy data from this entire week was discarded as invalid, although the MODAT activity counts were used.

The data collected shows generally that use of the radio channels is greater during the day shift and particularly from 9 AM to about 3 PM. However, daily variation from the norm were noted to be considerable. The highest occupancy was noted to be 890 seconds (or $890/3600 = 24.7\%$) occurring on April 3. In one case, (August 5) peak traffic occurred in the 4 to 5 AM time block in connection with early morning maintenance activity. On one day only (less than 1% of the time) did the peak occupancy on channel 1 exceed 24% (24.7% on April 3). It exceeded 12% occupancy for less than 10% of the time. The median occupancy (exceeded 50% of the time) was 6%. Traffic on channels 2 and 3 was never more than a fraction of channel 1 traffic.

Of particular interest were the "bed up" and "bed down" indications for the four dump trucks. The original hydraulic pressure actuated switches installed to signal these functions did not work. As a result, few indications were recorded during the first four months of the survey. In June, these were replaced with mechanically operated microswitches with feeler arms making direct contact with the dump bed when in the down position. Beginning July 12, regular bed up and bed down indications were recorded up to the end of the survey. These were compared with the logs kept by the drivers. For reasons not understood, these three sets of figures did not always agree. In general, records of bed down came closer to matching logged trips than the records of bed up.

1.3 Recommendations Made

Recommendations concerning the utilization of truck dump bed data, dispatching and operating procedures, elimination

of channel 3 and magazine entry records were made as a result of the evacuation. These recommendations are as follows:

1. It is recommended that the method of providing a bed-up or bed-down indication be examined. Both are not needed if one can be trusted. We suggest the use of a pressure sensitive switch on the high side of the hydraulic cylinder to be actuated each time the dump bed is raised. The system should be thoroughly tested for both false indications and failure to provide true indications. It should be possible to achieve a very high degree of reliability and to provide an accurate record of production by this method.

2. It is recommended that a dispatcher position be established and that standard operating procedures be developed. In an operation the size of Black River Limestone Company, the dispatcher could be a person with colateral duties, such as the hoist operator. Among the dispatcher's duties would be keeping track of which ID numbered portables had been issued and to what persons. He should keep track of where in the main particular persons are working and procedures should be established to keep this information updated. The dispatcher should be able to disable (knock down) the repeaters and operate the system as a group of wire-line controlled base stations. This provides the dispatcher with total control of the radio system and eliminates chaotic person-to-person transmissions which only serve to confuse the emergency situation. It should be the procedure in drills and emergencies for each radio equipped person to report the locations and status of himself and others for whom he may be responsible.

3. It is recommended that channel #3 be eliminated along with the three base/mobile repeaters, modems and voting modules associated with channel #3. The surface parts truck (ID #300) would shift its traffic over to channel #1. The equipment eliminated would go into the spares inventory. This action would reduce maintenance costs and eventual replacement costs. Future purchases of portable and mobile units need to specify only two channels. (Note: No data was taken on the "talk around" channels numbers 2, 4 and 6, but information furnished indicates that they were infrequently used.)

4. It is recommended that the automatic signalling of the presence of vehicles or persons at hazardous locations be made the subject of a future investigation.

1.4 Report Organization

A description of the radio system evaluated is contained in Section 2.0 of this report. Section 3.0 describes the data collection system implemented for the evaluation. The results of the data collection and the conclusions drawn relative to the utilization of the telecommunications system are presented in Sections 4.0 and 5.0 respectively. A cost benefit analysis is given in Section 6.0 and a comparison with other methods of

meeting the telecommunication needs on the mine is given in Section 7.0. Finally, the recommendations resulting from this project are given in Section 8.0

2.0 DESCRIPTION OF THE BLACK RIVER MINE
TELECOMMUNICATION SYSTEM

This section provides a summary description of the telecommunications system as it was configured at the time of the evaluation. A more detailed report of its design and implementation may be found in reference 3.

The telecommunications system is basically comprised of three Ultra-High Frequency (UHF) mobile relay sub-systems, each operating independently of the others. Two of the sub-systems (channels #1 and #3) are intended for use within the working portion of the mine and the third (channel #5) is used exclusively for communications in the slope entry of the mine. Use is made of three UHF frequency pairs in the Special Industrial Radio Service.

	<u>Base/Mobile</u>	<u>Mobile Only</u>
Channel #1	451.950MHz	456.950MHz
Channel #3	452.175MHz	457.175MHz
Channel #5	452.025MHz	457.025MHz

Seven 12-watt UHF Motorola Micor tone controlled base/mobile repeater stations are used. One of these operates on channel #5 which is used solely for communicating between the hoist operator and the brake car (or slope car) in the slope of the mine. The station is located in the hoist house and feeds a high gain antenna that is directed down the slope. The brake car is equipped with a mobile radio which normally is used on Channel #5 but can be switched to use channels #1 and #3 if channel #5 does not function. Alarm switches are provided on the brake car which can send digital alarm signals to the hoist operator.

Channel #1 and #3 systems employ three base/mobile repeaters each. These are located in pairs at the following locations (see Figure 2-1):

- a. The radio room near the mine portal with one antenna covering mine property above ground and a Yagi antenna directed into the slope for emergency communication with personnel in the slope.
- b. The radio and monitor building near crusher #2 where the base/mobile repeaters feed a distributed system that covers the central and western side of the mine.
- c. Near crusher #3, where the base/repeaters feed distributed antennas which cover the eastern half of the mine.

The channel #1 and #3 base/mobile repeater stations are each equipped with Spectra-Tac encoders for use with signal comparators located in the radio equipment room on the surface.

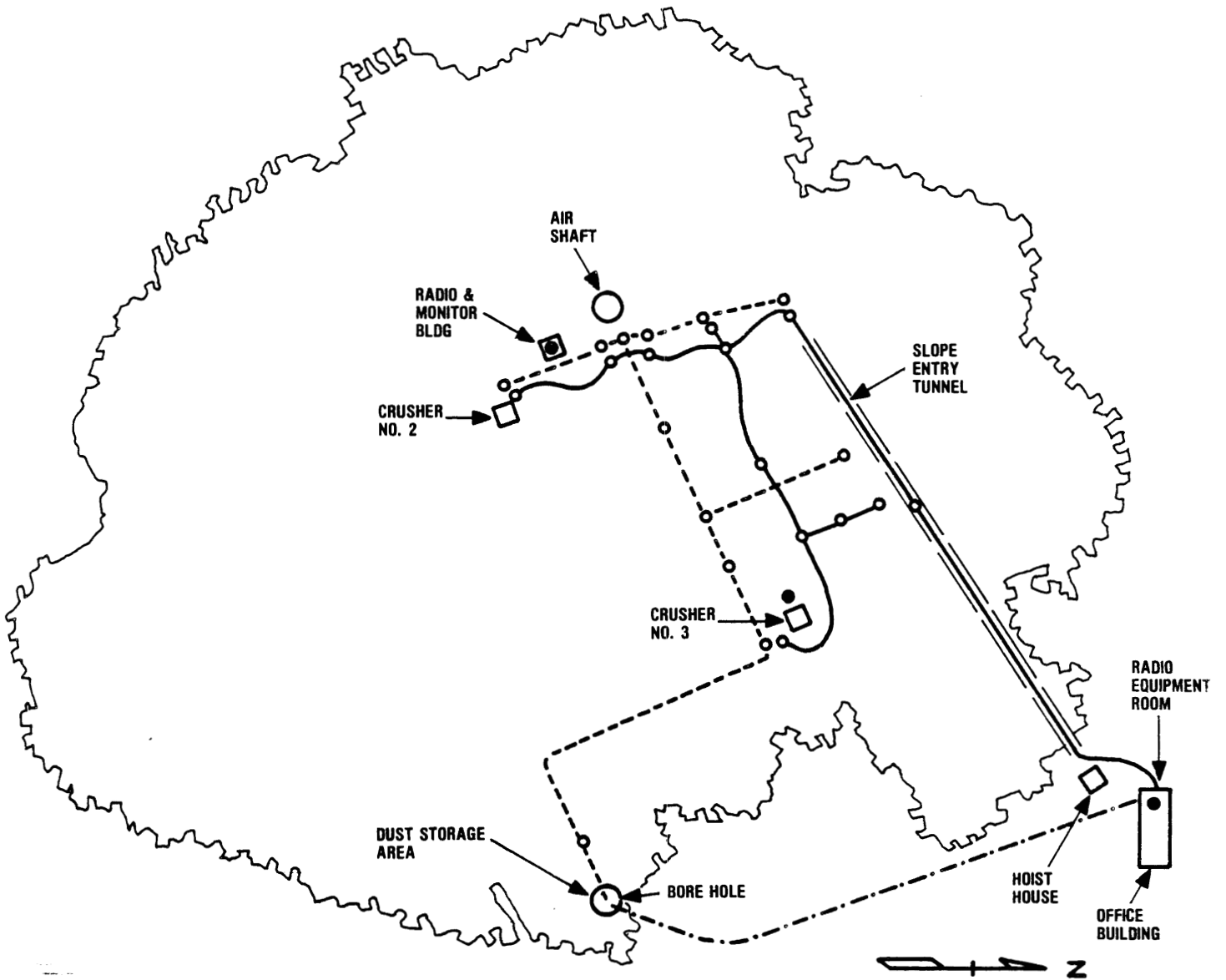

LEGEND

- BACK BONE CABLE NO. 1 INSTALLED THROUGH SLOPE.
- - -○- - - BACK BONE CABLE NO. 2 INSTALLED IN MINE.
- · - · - · - · - · BACK BONE CABLE ABOVE GROUND TO BORE HOLE
- THE CIRCLES IN THE CABLE REPRESENT MULTICOUPLERS FOR CONNECTING MULTIPLEXING FM MODULATORS OR DEMODULATORS
- BASE/MOBILE REPEATER STATION LOCATIONS

Figure 2-1. Black river mine telecommunications system.

Each comparator "votes" the best of three receiver outputs to be relayed over the system. In the absence of control tones, each repeater station reverts to an independent "in-cabinet" repeat mode.

There are three remote control consoles (wire line, tone control) in use in the system with each console having access to any of the three radio channels. Two are located in the mine office building. Of these, one is located in the engineering office and operates primarily on channel #1. The second is located in the reception area and is apparently utilized very little. The third console is located in the hoist house and operates primarily on channel #5.

The system also has three Radio Frequency (RF) control stations, each capable of controlling any of the three radio channels. One is located on the surface in the company warehouse area. The second is located at the base of the entrance slope and is used primarily on channel #5 for slope communications. The third RF control station is located in the underground shop area.

Two distributed antenna systems are used. The original system for the central and western sector of the mine used approximately 1,000 feet of 7/8" low-loss coaxial cable to feed four antennas through power dividers. Since coverage was inadequate at the perimeter of the mine, 5,600 feet of 1/2" low-loss coaxial cable, four two-way UHF signal boosters, and nine additional antennas and power dividers were installed.

The original antenna system for the eastern sector of the mine used approximately 1,600 feet of 7/8" low-loss coaxial cable to feed four antennas through power dividers. Approximately 4,000 feet of 1/2" low-loss coaxial cable and two two-way UHF signal boosters have been added to feed seven additional antennas through power dividers.

Most of the antennas are 5dB gain mobile whips that are attached to one-foot square metal plates which are bolted to the mine roof at the center of the intersecting crosscuts. Several 9dB base stations antennas, which are 15 feet long, are located in high crosscuts which do not have vehicular traffic. Passive reflectors are used to enhance signal strengths in crosscuts where signal strengths are marginal or unreliable. The locations and sizes of the reflectors were determined after the base/mobile repeaters stations and the distributed antennas were installed.

One of the unique features of the telecommunications system is the shared use of Community Antenna Television (CATV) cable which also carries closed circuit television and environmental status and alarm signals. This "backbone" cable system extends from the radio equipment room down the slope into the mine as shown in Figure 2-1. A redundant leg extends from the equipment room over the surface to the dust area bore hole and into the mine via that entrance. The cable carries

television video from cameras at the bottom of the slope, the crusher #3 conveyor belt transfer point, and at the dust storage area to monitors in the hoist house. Environmental monitors in the radio and monitor building (Figure 2-1) transmit air flow, temperature, fire particulates, carbon monoxide and nitrous oxide data over the cable to a display and printer in the engineering office on the surface. The cable also carries audio, digital and control tones interconnecting base/mobile repeaters, control consoles and comparators of the mobile radio system. It is only the radio system that is included in the evaluation.

Altogether, there were 12 11-watt mobile units and 15 2-watt portable units in use during the evaluation period. All were equipped with MODAT* configured to send a digital identification (ID) each time the PTT or emergency alarm switch was used. In addition, four mine dump trucks were modified to transmit a "bed-up" (truck bed up for dumping) and a "bed-down" signal as appropriate.

There are three MODAT decoders called Basic Logic Units (BLU) installed in the system, all of which are physically located in the engineering office. All three are interfaced to display consoles while only the channel #1 BLU is interfaced to a printer device.

Mobile and portable unit assignments by ID number in effect during the evaluation period are given in Table 2-1.

*"MODAT" is a registered trademark of Motorola Communications, Inc. used in connection with their mobile radio data transmission system. Reference to specific brands, equipment or trade names in this report is made to facilitate understanding and does not imply indorsement by The Bureau of Mines.

TABLE 2-1. TABLE OF RADIO ASSIGNMENT

1. Portable Units:

UNIT #	PHYSICAL/TASK ASSIGNMENT
001	Maintenance Foreman
002	Lime Plant
003	Production Foreman #2
004	Engineering
005	Underground Electrician
006	Radio Maintenance
007	Spare (Not Used)
008	Conveyor Operator
009	Mr. Kuehneman
010	Spare
011	Water Truck
012	Production Foreman #1
013	Powder Crew
014	Half-way (belt transfer point)
015	Safety Director

2. Mobile Units:

UNIT #	PHYSICAL/TASK ASSIGNMENT
100	Slope Car
101	Scaler
108	Dump Truck #8
109	Dump Truck #9
110	Dump Truck #10
111	Dump Truck #11
211	Jumbo Drill #11
219	Loader #219
220	Loader #220
224	Loader (Yale)
226	Loader (Yale)
300	Surface Parts Truck
920	Loader #920

3.0 DATA COLLECTION SYSTEM

A custom Data Collection System (DCS) was engineered and built by ARC to perform the task of collection for the large amount of data anticipated in the project. Many different devices could have been employed with varying degrees of ease of implementation. A microcomputer was chosen for speed and versatility.

Two types of data were collected and stored by the DCS. Hardware data was automatically extracted from the radio system hardware through direct interface. Maintenance data was entered into the DCS by the on-site maintenance contractor. Management and production data required from the mine's management was collected and correlated by hand.

The operation of the DCS is as follows:

1. The DCS keeps a real time clock and a month/day date as a background operation. Time resolution is a minimum of ten millisecond intervals.
2. The SYSTEM and MODAT channels are asynchronously monitored for changes in hardware status and incoming MODAT data through the use of vectored interrupts.
3. These data elements are time-tagged and placed onto a mass storage device.
4. By the use of a dial-up communications modem, this data is down loaded into the data processing facilities at ARC in Alexandria for compression and processing.
5. When appropriate, manual data collection programs are run in the background to accept and store maintenance data.

The DCS controller software is written entirely in fast, efficient assembly language. The entire DCS is operated from uninterrupted power which is available on site and also powers the telecommunications system.

3.1 DCS Hardware Description

The design of the DCS centers around a dedicated microcomputer. A series of specialized interface channels communicate with the telecommunications system equipment while a mass storage device accumulates the collected data between weekly down-loading intervals.

A block diagram of the DCS is shown in Figure 3-1. It contains a Central Processing Unit (CPU) card based on the 8-

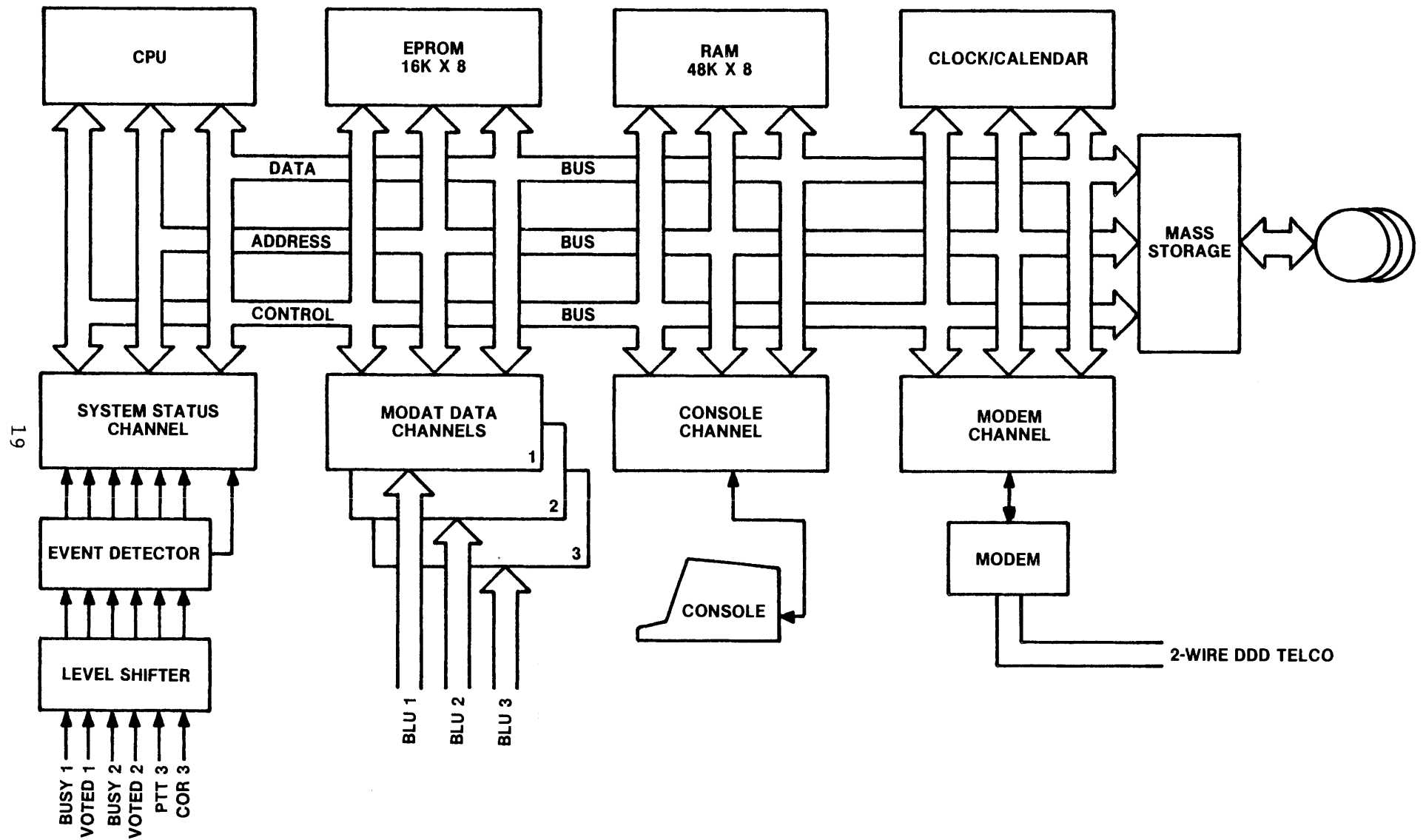

Figure 3-1. DCS block diagram.

bit, Zilog Z80B microprocessor chip. The memory complement is made up of 48K of Random Access Memory (RAM) for program storage and 16K of RAM for data storage and general working space. A clock/calendar card develops real time clock information which includes 24-hour clock with 100 micro-second resolution and a five digit Julian day calendar. Three of the parallel interface cards, referred to as the MODAT channels, monitor the MODAT Basic Logic Units (BLU). Another parallel interface card, referred to as the SYSTEM channel, monitors strategic logic points within the communications systems hardware. A serial CONSOLE channel and a serial MODEM channel complete the communications channels to and from the DCS controller. The mass storage device is a 20 Mbyte, fixed platter, hard disk system. The majority of the components were off-the-shelf circuit boards and modules.

Figure 3-2 depicts a portion of the telecommunications equipment that is of primary interest to the data collection process. Also shown are the points of interface to the MODAT data streams which were monitored in parallel with the existing display and printer equipment.

Interface to the telecommunications system was accomplished by a two level process as shown in Figure 3-3. MODAT data had to be recovered from each sub-system in an expedient and reliable fashion without drastic interruption of service to the mine telecommunication system. Customized parallel interface channels were designed and fabricated in order to interface with the particular version of BLU currently being employed at the mine.

The DCS was installed in the mine engineering office, immediately adjacent to the three BLU's. This was done to reduce noise susceptibility of the extensive parallel interfacing between the BLU's and the DCS.

3.2 Modat Data

The communications hardware was equipped with MODAT capability at the start of the data collection process. The majority of the radios are equipped to automatically send a three-digit identification code (ID) each time the push-to-talk button is activated. A two digit MODAT data/message code is also transmitted with the ID. The system currently employs two status codes: normal PTT and emergency PTT; and four message codes: bed up, bed down, and several location codes.

These data bursts are automatic to the communications and are decoded by the BLU and presented to a console display and printer. The DCS monitors the data at this point by monitoring the various BLU strobe lines to detect that new data is present on the parallel interface.

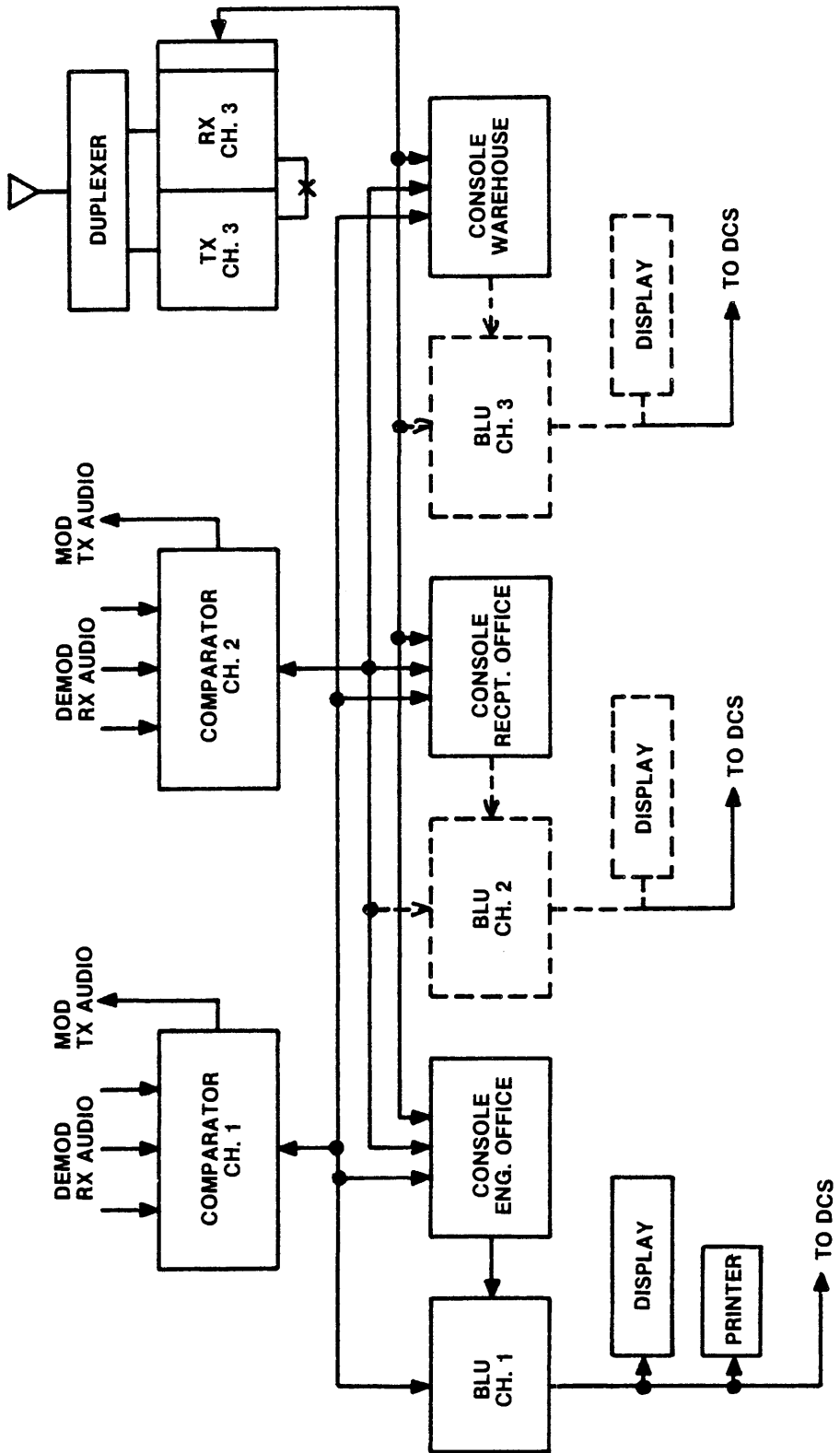

Figure 3-2. Surface equipment block diagram.

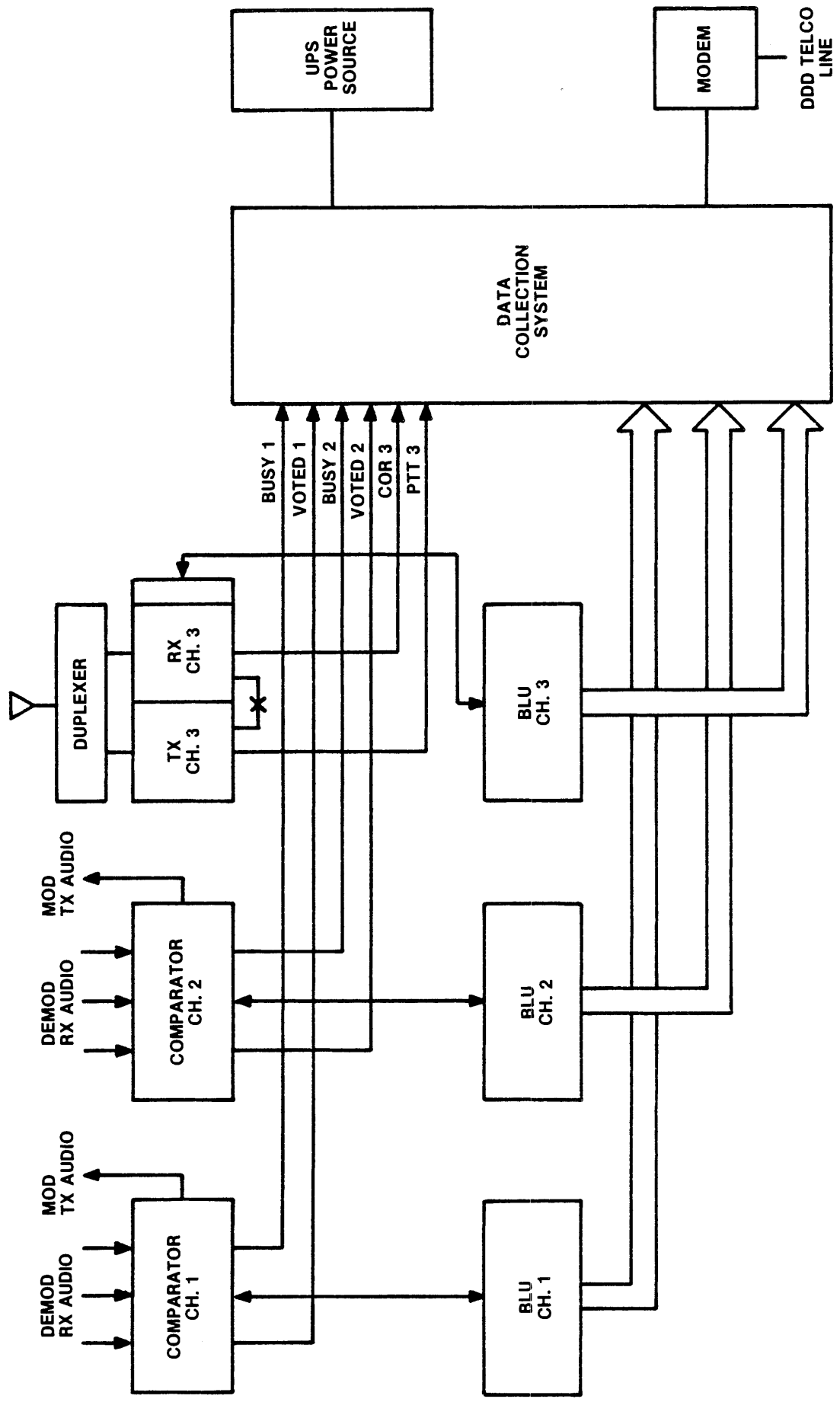

Figure 3-3. DCS interconnect diagram.

3.3 Systems Status Channels

In addition to the MODAT data, several discrete logic points within the telecommunication system's hardware are monitored by the SYSTEM channel of the DCS. This channel is an eight bit parallel port with two special modifications. Electrical isolation and TTL level conversion is performed on all incoming status lines. Additionally, a status change circuit serves to detect a logic level change in any of the the six status bits being monitored. By creating this 'status changed' signal and employing it as a processor interrupt device, considerable processor overhead is saved because constant polling is not necessary.

These logic points included the 'voted' and the 'failed' status indicators available within each receiver voting comparator card on channels 1 and 3. Also the 'tone priority' status, which indicates system control is via one of the wire line remote control consoles, is monitored. The carrier operated relay (COR) and push-to-talk (PTT) indicators are used for channel #5 as this system is not equipped with voting comparators.

The comparator's 'voted' indicator is true whenever the mobile relay transmitters are being keyed on by the voting comparator. This applies for both the voted repeat mode of operation and remote mode of operation when the system is being keyed by a remote control console.

The comparator's 'tone priority' indicator is true only when the mobile relay transmitters are being keyed on and keying is initiated by a remote control console. Hence, if only the 'channel voted' indicator is true then a repeat mode operation is in effect. If the 'channel voted' and the 'tone priority' are true coincidentally, then a remote control console transmit operation is in progress.

The PTT and COR lines of the channel 5 mobile relay will perform the same basic function as the 'channel voted' and the 'tone priority' indicators respectively. In its basic form, this data would yield the needed information regarding the length of transmission which is not available from the MODAT equipment.

Since this system STATUS data is collected in the same time domain as the MODAT data, the two sets of data can be correlated to determine the length of transmission for a particular MODAT identified unit and subsequently a grouping of units. As discussed earlier, remote control consoles and control stations do not generate MODAT ID data. It can be concluded, however, that a true 'tone priority' or 'PTT' indicator with no corresponding MODAT ID can be directly attributed to transmissions initiated exclusively from remote control consoles (wire line control). Correspondingly, true 'channel voted' indicators or simultaneous 'COR' and 'PTT' indicators with no corresponding MODAT ID point to transmissions initiated

exclusively from remote control stations (RF control). It must be clearly pointed out that although the groups of consoles and the group of stations can be distinguished, they cannot be individually identified.

The following is the format by which the data gathered by the DCS is stored for later retrieval and processing.

Stored data block format for hardware STATUS information.

<u>BYTE #</u>	<u>DATA</u>
1	CHANNEL #, 1, 3, or 5, ASCII
2	DATE - Julian day, hundreds digit, ASCII
3	DATE - Julian day, tens digit, ASCII
4	DATE - Julian day, ones digit, ASCII
5	TIME - Hours, tens digit, ASCII
6	TIME - Hours, ones digit, ASCII
7	TIME - Minutes, tens digit, ASCII
8	TIME - Minutes, ones digit, ASCII
9	TIME - Seconds, tens digit, ASCII
10	TIME - Seconds, ones digit, ASCII
11	TIME - Seconds, tenths digit, ASCII
12	TIME - Seconds, hundredths, digit, ASCII
13	PLACE HOLDER - '@', ASCII
14	PLACE HOLDER - '@', ASCII
15	PLACE HOLDER - '@', ASCII
16	PLACE HOLDER - '@', ASCII
17	PLACE HOLDER - '@', ASCII
18	STATUS - Old system status, BINARY
19	STATUS - New system status, BINARY
20	'RS' - Record separator, 1E hexadecimal

Stored data block format for MODAT information.

<u>BYTE #</u>	<u>DATA</u>
1	CHANNEL #, 1, 3, or 5, ASCII
2	DATE - Julian day, hundreds digit, ASCII
3	DATE - Julian day, tens digit, ASCII
4	DATE - Julian day, ones digit, ASCII
5	TIME - Hours, tens digit, ASCII
6	TIME - Hours, ones digit, ASCII
7	TIME - Minutes, tens digit, ASCII
8	TIME - Minutes, ones digit, ASCII
9	TIME - Seconds, tens digit, ASCII
10	TIME - Seconds, ones digit, ASCII
11	TIME - Seconds, tenths digit, ASCII
12	TIME - Seconds, hundreths, digit, ASCII
13	MODAT - Data, tens digit, ASCII
14	MODAT - Data, ones digit, ASCII
15	MODAT - ID #, hundreds digit, ASCII
16	MODAT - ID #, tens digit, ASCII
17	MODAT - ID #, ones digit, ASCII
18	STATUS - Old system status, BINARY
19	STATUS - New system status, BINARY
20	'RS' - Record separator, 1E hexadecimal

Three typical exchanges are depicted below with data blocks shown as they would be recorded for the particular situation.

<u>Exchange #1 - Portable to Portable</u>	<u>Operation</u>	<u>Data Block</u>
	Portable #1 keys Tx	
	Carrier received by system	"S" - Voted
	Comparator keys relay	"S" - Busy
	Portable #1 sends ID	
	BLU receives ID - no errors	"M" - DATA + ID #1
	Portable #1 sends voice msg	
	Portable #2 receives voice msg	
	Portable #1 unkeys	"S" - Not Voted
		"S" - Not Busy
		(see note 1)
	Portable #2 keys Tx	
	Carrier received by system	"S" - Voted
	Comparator keys relay	"S" - Busy
	Portable #2 sends ID	
	BLU receives ID - no errors	"M" - DATA + ID #2
	Portable #2 sends voice msg	
	Portable #1 receives voice msg	
	...	
	...	
	All parties unkey	
	Carrier lost by system	"S" - Not Voted
	Comparator unkeys relay	"S" - Not Busy

Exchange #2 - Portable to Control Console

<u>Operation</u>	<u>Data Block</u>
Portable #1 keys Tx	
Carrier received by system	"S" - Voted
Comparator keys relay	"S" - Busy
Portable #1 sends ID	
BLU receives ID - no errors	"M" - DATA + ID #1
Portable #1 sends voice msg	
Portable #1 unkeys	"S" - Not Voted "S" - Not Busy (see note 1)
Control Console receives voice msg	
Control Console keys Tx	
Keying tones received by system	
Comparator keys relay	"S" - Busy
BLU sends originate msg	"M" - DATA, NO ID
Control console sends voice msg	
Portable #1 receives voice msg	
...	
...	
All parties unkey	
Carrier lost by system	"S" - Not Voted
Comparator unkeys relay	"S" - Not Busy

Exchange #3 - Mobile Status Report Only

<u>Operation</u>	<u>Data Block</u>
Mobile #1 changes status	
Mobile #1 Tx keys automatically	
Carrier received by system	"S" - Voted
Comparator keys relay	"S" - Busy
Mobile #1 sends ID	
BLU receives ID - no errors	"M" - DATA + ID #1
Mobile #1 un-keys	
Carrier lost by system	"S" - Not Voted
Comparator unkeys relay	"S" - Not Busy

Note: 1 - System may or may not go 'Not Busy' depending on the delay between the loss of carrier (and voted status) and the termination of the transmit keying tones sent to the relay transmitters by the comparator.

4.0 DATA COLLECTION RESULTS

Data collection began on February 27, 1982, and continued through August 27, 1982. Data was collected for each day on which activity occurred, including Saturdays, Sundays and holidays. However, little use of the radio was made on other than regular Monday through Friday work days, so that weekend traffic was of no great significance. From the data, daily records were derived of channel occupancy in seconds for each one-hour time block during the day, transactions for each one-hour time block during the day, and daily activity counts for each MODAT equipped radio. Samples of these records are shown in Tables 4-1 and 4-2 for August 2, 1982 (Julian date 214). Valid records of this type were obtained for 111 days (Table 4-1) and 116 days (Table 4-2) out of a total of 127 work days (i.e., 26 five-day weeks less three holidays) included in the data collection period. Data collection system malfunctions accounted for the loss of records from Saturday, April 17 through Wednesday, April 21, and from Tuesday, May 18 through Monday, May 24. During the week preceding the second system outage, a failing clock module resulted in unrealistically high occupancy levels (i.e., occupancies greater than 3600 seconds in a one hour period). The occupancy data from this entire week was discarded as invalid, although the MODAT activity counts were used.

Histograms summarizing the occupancy and transaction data are shown in Appendix A. Page 63 of Appendix A shows averages of both occupancy in seconds and transactions for channel #1 for the entire period of the survey. The "hour" column in these and TABLE 4-1 all other histograms indicates the beginning of each hourly time block. For example, "9" indicates the time block beginning at 9 AM and ending at 10 AM. Since a 24 hour clock is used, "13" indicates the time block beginning at 1 PM, "14" indicates the time block beginning at 2 PM, etc.

Page 64 shows average occupancy in percentage of the hour (3600 seconds) and the average message lengths by hourly time block, both for channel #1 for the entire period of the survey. Average message lengths were obtained by dividing the total occupancy in seconds for the period by the total transaction count. "Transactions" include all radio message originations regardless of whether or not the originating unit is equipped with a MODATS which provides unit identification and type of transaction.

Pages 65 through 68 show similar information for channels #3 and #5. Histograms for the three channels are continued on pages 68 onwards except that each shows data averages over all the valid daily records for a single month. Each table shows the inclusive dates that apply.

The information in Appendix A shows generally that use of the radio channels is greater during the day shift and particularly from 9 AM to about 3 PM. However, daily variation from the norm were noted to be considerable.

Table 4-1. Total system occupancy record for August 2, 1982.

BLACK RIVER MINE -- DCS SYSTEM OCCUPANCY REPORT FILE: C:08/09.CH1

Total System Occupancy for Julian day/days: 214

HOUR OF DAY	SYSTEM USAGE IN SECONDS	VALID TRANSACTIONS
00	0.00	0
01	0.00	0
02	0.00	0
03	0.00	0
04	0.00	0
05	0.00	0
06	0.00	0
07	9.15	4
08	125.98	51
09	107.65	52
10	257.75	126
11	189.36	65
12	121.92	56
13	159.12	72
14	121.95	66
15	42.60	28
16	64.04	19
17	49.58	30
18	88.39	42
19	32.26	11
20	0.10	1
21	0.00	0
22	0.00	0
23	0.00	0
	1369.85	623

TOTAL CHANNEL TRANSACTION COUNT: 629

Table 4-2. Unit activity report for August 2, 1982.

BLACK RIVER MINE -- DCS MODAT ACTIVITY REPORT FILE: C:08/09.CH1

Unit Activity Report for Julian Day/Days: 214

ID	ASSIGNMENT	(98)	(97)	(83)	(82)	(81)	(80)
001	Maintenance	0	0	0	0	0	0
002	Lime Plant	0	0	0	0	0	0
003	Prod Foreman #2	13	0	0	0	0	0
004	Engineering	0	0	0	0	0	0
005	Underend Elect	12	0	0	0	0	0
006	Radio Maint	0	0	0	0	0	0
007	Spare	0	0	0	0	0	0
008	Conveyor	6	0	0	0	0	0
009	Mr. Kuehneman	5	0	0	0	0	0
010	Spare	86	0	0	0	0	0
011	Water Truck	0	0	0	0	0	0
012	Prod Foreman #1	0	0	0	0	0	0
013	Powder Crew	9	0	0	0	0	0
014	Half-Way	8	0	0	0	0	0
015	Safety Director	3	0	0	0	0	0
100	Slope Car	0	0	0	0	0	0
101	Scaler	0	0	0	0	0	0
106	Truck #6	0	0	0	0	0	0
108	Truck #8	2	0	0	0	40	28
109	Truck #9	4	0	0	0	35	32
110	Truck #10	30	0	0	0	38	33
111	Truck #11	14	0	0	0	32	30
211	#11 Jumbo Drill	0	0	0	0	0	0
219	#219 Loader	0	0	0	0	0	0
220	#220 Loader	0	0	0	0	0	0
224	#224 Loader (Y)	0	0	0	0	0	0
226	#226 Loader (Y)	0	0	0	0	0	0
300	Surf Pts Truck	0	0	0	0	0	0
920	#920 Loader	0	0	0	0	0	0
504	TEST RADIO	0	0	0	0	0	0
@@@	Non-ID Blocks	1680	0	0	0	0	0

1872 0 0 0 145 123

Total Data Blocks Read: 2143

Total Bad ID Numbers: 0 Total Bad Modat Numbers: 3

MODAT FUNCTIONS:

- (98) = Normal PTT - ALL Units.
- (97) = Emergency PTT - ALL Units.

MODAT DATA:

- (83) = Clear of all Magazines - #300 only.
- (82) = In Blasting Cap Magazine - #300 only.
- (81) = Bed Down - #106, 108, 109, 110, 111.
In Dynamite Magazine - #300 only.
- (80) = Bed Up - #106, 108, 109, 110, 111.
In Powder Magazine - #300 only.

It is the daily peaks or "busy hours" of a communication system that determine its required capacity. To show this for the Black River Mine system, Table 4-3 was prepared. This table shows the maximum one-hour occupancy in seconds for each of the three channels for each work day for which a valid record was obtained. Also shown is the time block during which this peak traffic occurred. Scanning this table will show a substantial fluctuation not only in the peaks but in the time of day they occur. The highest occupancy is noted to be 890 seconds (or $890/3600 = 24.7\%$) occurring on April 3. In one case, (August 5) peak traffic occurred in the 4 to 5 AM time block in connection with early morning maintenance activity. Scanning the table also makes it immediately apparent that traffic on channels 3 and 5 is only a fraction of that on channel 1.

Figure 4-1 shows the distribution of peak occupancies for channel 1 for the entire period of the survey (i.e., for 111 days for which there are valid data records). From this it can be seen that only on one day (less than 1% of the time) did the peak occupancy exceed 24% (24.7% on April 3). It can be said to exceed 12% occupancy for less than 10% of the time. The median occupancy (exceeded 50% of the time) is 6%.

The effect of channel occupancy on congestion can be determined from Figure 4-2. This shows the percentage of messages (X-axis) delayed by more than the amount indicated on the Y-axis for various values of occupancy. For example, if the busy hour occupancy is 20%, then 20% of messages are likely to be delayed more than zero because of channel congestion. Ten percent are likely to be delayed more than 0.85 times the average message length. Five percent are expected to be delayed more than 1.75 message lengths, and so on. Obviously, the average message length is itself an important determinant of congestion delay, thus short messages increase channel efficiency. Average message lengths for each time are shown in Appendix A.

A summary of the weekly totals of activity counts of ID equipped radios is given in Table 4-4. This is a summary of the type of data shown in the first column of Table 4-2. Each number indicates how often the push-to-talk (PTT) button was pushed during the week on the radio identified. Totals for the entire period of the survey and the percentages of the total activity that each radio accounts for are given. Activity for all three channels is combined in the table. However, with rare exception, only the surface parts truck initiated activity on channel #3 and only the slope car used channel #5. One spare unit (ID #007), truck #6 (ID #106) and the jumbo drill (ID #211) were omitted entirely from the table because no activity was ever recorded for these units. The five loaders were grouped together because the combined activity for these units was very small. Some units were down for extended periods because the units themselves were down or their ID's were inoperative. This is known to be true for trucks #8, #10 and #11 during March, and for the scaler (ID #101) from March until mid June. No activity is

Table 4-3. Peak (busy hour) occupancies in seconds.

DATE	CHANNEL 1		CHANNEL 3		CHANNEL 5		
	PEAK	TIME BLOCK	PEAK	TIME BLOCK	PEAK	TIME BLOCK	
MARCH	1	186	10	112	11	60	16
	2	334	9	59	13	86	8
	3	323	21	93	9	40	15
	4	166	10	63	10	75	15
	5	435	17	52	13	27	15
	8	261	9	152	9	12	8
	9	528	11	70	11	40	9
	10	199	13	47	9	23	9
	11	162	9	52	9	48	16
	12	240	10	44	10	19	8
	15	181	9	33	14	38	21
	16	204	9	49	9	12	8
	17	420	13	70	11	30	8
	18	354	12	43	11	36	15
	19	215	10	28	9	22	9
	22	452	9	60	10	25	9
	23	117	10	27	12	25	8
	24	314	12	51	12	165	12
	25	192	12	61	9	51	17
26	182	13	68	9	47	17	
29	805	13	25	13	34	16	
30	127	1	38	11	30	18	
31	384	12	18	14	52	8	
APRIL	1	361	9	30	9	17	8
	2	387	13	46	9	16	8
	5	317	15	71	12	12	17
	6	351	10	30	9	25	10
	7	257	12	45	13	22	20
	8	411	10	45	9	11	23
	12	261	13	64	11	87	21
	13	183	16	40	13	11	16
	14	221	14	67	9	11	15
	15	240	10	73	TIE 12/14	28	10
	16	138	9	47	11	291	16

Table 4-3. Peak (busy hour) occupancies in seconds (continued).

DATE	CHANNEL 1		CHANNEL 3		CHANNEL 5		
	PEAK	TIME BLOCK	PEAK	TIME BLOCK	PEAK	TIME BLOCK	
APRIL	22	264	13	20	10	28	10
	23	225	12	59	10	8	7
	26	164	8	59	9	5	7
	27	83	12	35	10	8	7
	28	175	12	50	8	5	7
	29	248	13	94	17	5	13
	30	164	10	19	11	4	13
MAY	3	890	7	54	7	35	18
	4	152	12	121	8	9	8
	5	175	9	73	8	36	11
	6	195	11	29	9	58	12
	7	145	12	28	20	10	20
	25	178	10	39	11	0	—
	26	247	9	76	9	25	13
	27	178	8	43	9	0	—
	28	604	13	56	13	---MISSING PAGE---	
	JUNE	1	252	8	24	21	7
2		237	14	51	18	---MISSING PAGE---	
3		324	8	57	13	111	9
4		221	8	77	9	18	16
8		63	14	14	21	9	15
9		217	8	358	17	31	17
10		236	11	39	13	75	9
11		302	9	54	9	58	10
14		341	11	21	8	19	8
15		168	9	25	13	28	15
16	187	13	73	10	20	11	
17	152	8	69	11	8	7	
18	157	11	215	11	10	7	

Table 4-3. Peak (busy hour) occupancies in seconds (continued).

DATE	CHANNEL 1		CHANNEL 3		CHANNEL 5		
	PEAK	TIME BLOCK	PEAK	TIME BLOCK	PEAK	TIME BLOCK	
JUNE	21	194	13	27	11	26	15
	22	151	11	74	9	86	14
	23	175	13	50	9	27	9
	24	347	9	88	8	9	7
	25	328	8	46	18	10	15
	28	429	12	41	21	15	8
	29	361	10	34	9	68	9
JULY	1	168	15	9	14	12	17
	2	189	22	26	14	80	9
	6	251	9	56	8	22	16
	7	302	11	82	8	58	16
	8	284	11	48	11	101	18
	9	216	9	34	12	16	17
	12	158	9	86	14	60	13
	13	251	14	64	14	177	16
	14	243	11	30	14	24	13
	15	258	11	49	10	91	14
	16	233	9	33	11	115	16
	19	336	10	89	9	19	9
	20	215	9	19	9	28	17
	21	167	14	70	9	154	16
	22	175	14	12	9	36	13
	23	207	10	51	15	11	15
	26	150	9	54	14	134	16
27	225	14	12	12	66	16	
28	225	11	103	14	8	8	
29	288	9	18	9	0	—	
30	152	14	61	9	0	—	

Table 4-3. Peak (busy hour) occupancies in seconds (continued).

DATE	CHANNEL 1		CHANNEL 3		CHANNEL 5	
	PEAK	TIME BLOCK	PEAK	TIME BLOCK	PEAK	TIME BLOCK
AUGUST 2	258	10	25	9	0	—
3	389	13	88	10	57	12
4	269	16	27	9	29	21
5	477	4	48	11	50	7
6	139	11	25	9	40	9
9	466	13	33	9	114	8
10	444	14	95	10	110	17
11	451	9	75	9	108	14
12	214	9	39	11	10	10
13	315	11	58	11	63	20
16	274	11	94	9	124	17
17	160	12	36	12	33	13
18	296	13	137	9	62	17
19	320	12	70	9	70	21
20	294	9	37	10	48	13
23	280	8	25	8	9	16
24	142	11	43	9	71	8
25	171	12	91	11	49	17
26	362	11	29	11	28	12
27	212	9	23	9	25	16

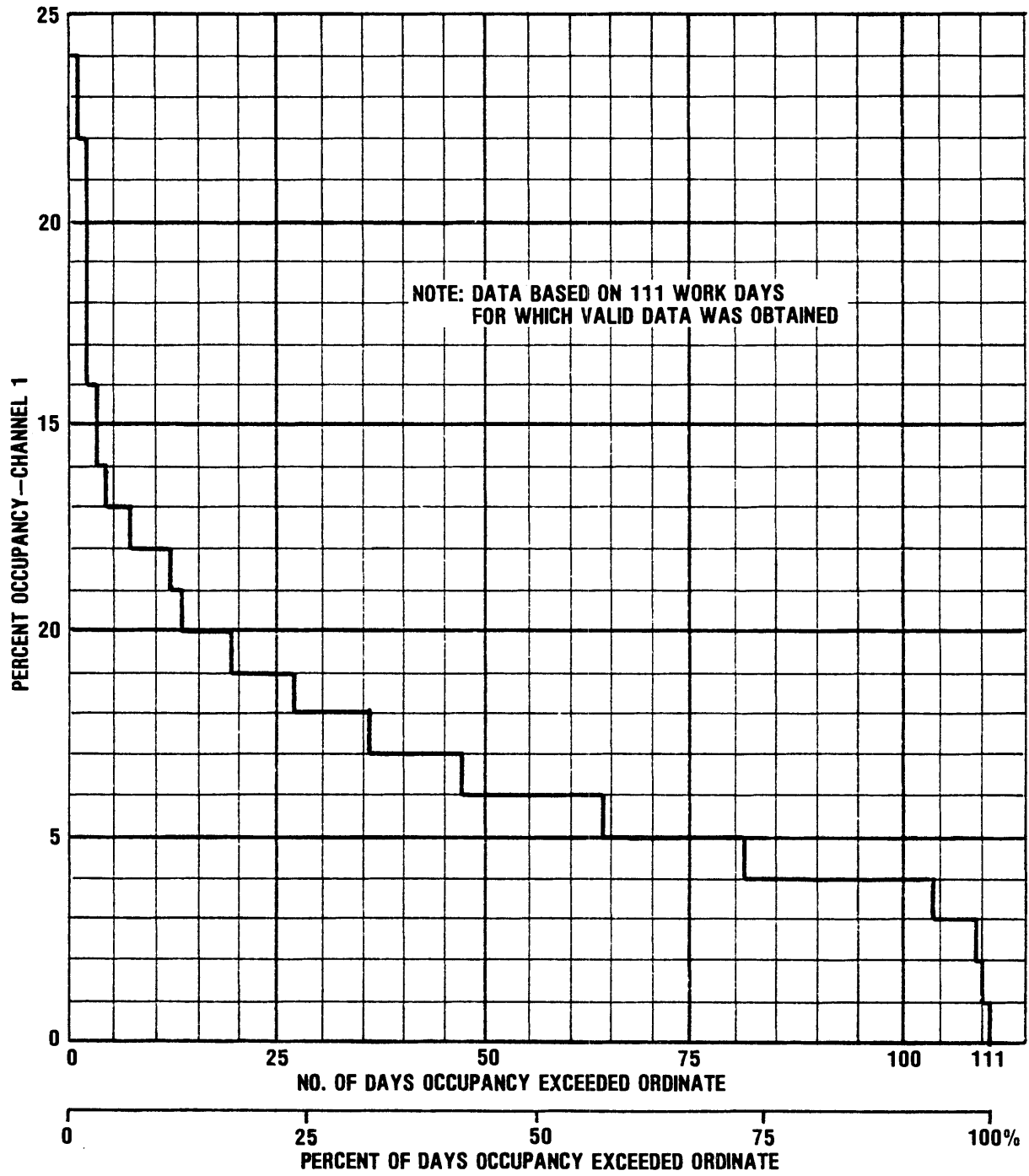

Figure 4-1. Cumulative distribution of busy hour channel occupancies—channel #1.

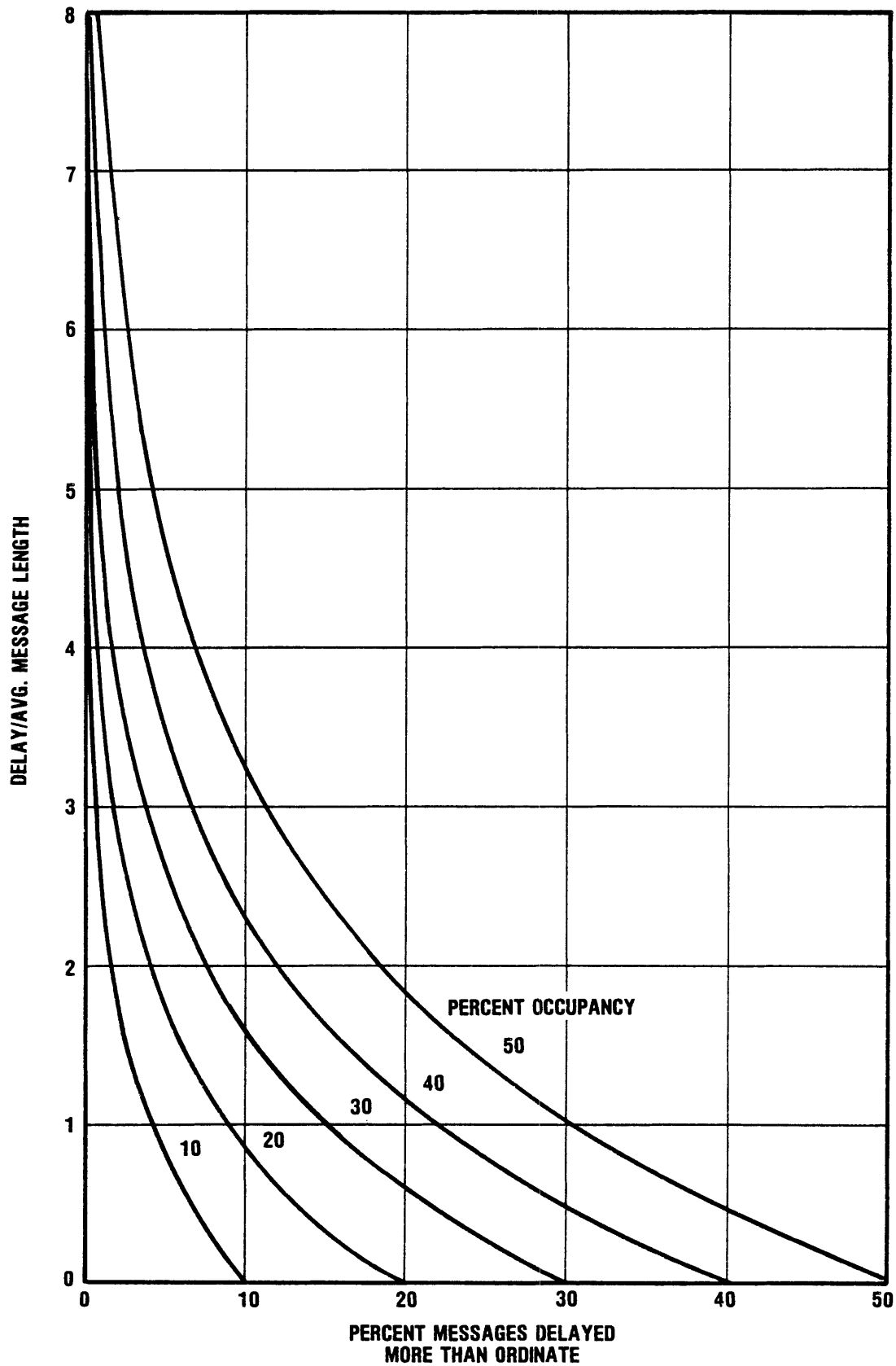

Figure 4-2. Affect of channel occupancy of congestion delays.

Table 4-4. Radio transmission initiated (normal PTT) by ID equipped radios.

ID	ASSIGNMENT	WEEK ENDING																	TOTALS	PERCENT									
		3/5	3/12	3/19	3/26	4/2	4/9	4/16	4/23	4/30	5/7	5/14	5/21	5/28	6/4	6/11	6/18	6/25			7/2	7/9	7/16	7/23	7/30	8/6	8/13	8/20	8/27
001	MAINTENANCE	344	366	422	273	404	254	259	120	340	219	314	248	282	180	148	100	179	6	84	0	1	0	0	0	136	88	4767	22.62
002	LIME PLANT	102	58	0	6	13	55	33	7	0	33	0	0	0	0	24	36	46	7	6	9	4	4	0	44	67	2	552	2.62
003	FOREMAN #2	0	100	301	134	66	60	57	11	12	38	7	46	42	16	44	12	1	0	20	10	28	28	4	0	0	1037	4.92	
004	ENGINEERING	6	20	22	9	14	6	5	11	18	11	11	37	39	21	11	97	47	4	6	29	8	30	22	15	21	520	2.47	
005	ELECTRICIAN	146	97	116	77	169	81	115	37	74	57	31	35	38	53	44	121	98	23	23	3	62	16	0	34	169	0.8		
006	RADIO MAINT.	0	0	8	2	1	0	10	0	0	9	0	3	27	0	6	6	2	50	35	0	0	0	0	16	0	169	0.8	
008	CONVEYOR	61	75	79	46	134	63	35	16	32	21	82	28	1	17	24	27	4	23	36	42	51	109	134	91	80	1311	6.22	
009	KUEHNEMAN	1	2	0	9	296	32	24	4	22	16	21	2	45	58	45	53	32	29	53	0	56	20	25	28	15	888	4.21	
010	SPARE	0	1	0	0	6	271	1	0	0	15	21	37	69	25	131	39	16	25	40	115	67	225	163	46	47	1360	6.45	
011	WATER TRACK	55	81	57	56	26	11	0	0	0	0	0	1	78	11	28	67	0	14	16	43	16	26	0	32	31	649	3.08	
012	FOREMAN #1	27	7	6	1	28	27	112	0	0	0	18	64	101	59	69	69	15	7	8	15	18	21	30	96	55	853	4.05	
013	POWDER CREW	50	49	16	77	70	62	65	24	102	63	81	0	0	17	98	4	2	10	18	20	43	67	30	23	56	1047	4.97	
014	HALF-WAY	2	166	85	194	300	83	0	11	71	34	85	124	59	28	102	56	20	32	25	85	112	83	102	72	52	1983	9.41	
015	SAFETY DR.	59	16	22	23	45	34	25	0	16	3	4	49	0	21	49	28	12	24	48	28	39	33	59	85	25	747	3.54	
100	SLOPE CAR	26	33	26	65	66	34	74	12	7	15	7	3	23	21	16	14	27	0	0	0	0	1	0	0	0	470	2.23	
101	SCALER	0	0	0	0	0	1	1	0	0	0	0	0	0	9	14	0	0	0	0	0	0	0	0	0	0	25	0.12	
108	TRUCK #8	0	0	0	0	4	13	3	0	0	0	25	30	0	0	0	0	3	2	15	2	17	7	1	16	5	143	0.68	
109	TRUCK #9	23	25	31	22	28	11	19	5	8	21	17	0	26	11	29	75	7	5	22	8	22	23	31	28	24	521	2.47	
110	TRUCK #10	0	0	0	0	22	70	51	28	24	11	80	37	82	19	47	70	6	11	32	7	25	64	45	47	51	829	3.93	
111	TRUCK #11	0	0	0	0	37	63	41	1	0	0	28	0	0	0	0	0	5	10	36	22	75	55	58	36	25	492	2.33	
	5 LOADERS	0	0	2	0	1	6	0	0	5	0	0	0	0	0	0	0	0	0	0	0	0	0	0	0	0	14	0.07	
300	SURF. PARTS	68	69	57	60	43	61	48	29	43	43	58	68	42	15	65	32	4	29	29	17	47	31	76	84	55	1173	5.57	
	CHAN. 1 TOTAL	876	1064	1158	930	1922	932	852	275	723	536	825	758	874	540	911	858	491	226	500	429	638	804	756	795	680	19273	91.44	
	CHAN. 3 TOTAL	68	71	66	65	50	62	51	29	44	58	58	52	57	20	67	41	8	45	52	26	53	35	84	107	66	1335	6.33	
	CHAN. 5 TOTAL	26	33	26	65	66	34	74	12	7	15	7	3	23	21	16	14	27	0	0	0	0	0	0	0	0	469	2.23	
	TOTAL ACTIVITY	970	1168	1250	1060	2038	1028	977	316	774	609	890	813	954	581	994	913	526	271	552	455	681	839	840	902	666	21077		

shown for the slope car after July 9. This is probably due to a failure of the ID, since occupancy levels on channel #5 (Table 4-3) continue about the same.

Recorded activity also included emergency PTT, bed up and bed down indications for the dump trucks, and "clear all magazines", "in blasting cap magazine", "in dynamite magazine" and "in powder magazine" applicable only to the surface parts truck.

Emergency PTT's were recorded as follows for the six month period.

Line Plant	55
Engineering	21
Electrician	22
Spare (ID #010)	25
Water Truck	8
Powder Crew	4
Slope Car	23
Truck #9	2
Truck #10	2
Truck #11	6
5 Loaders	4
Surface Parts Truck	7

However, the mine reports no bona fide emergencies during this period except for the slope car. The slope car is configured to transmit an emergency signal whenever the automatic over-speed brakes are applied. This is reported to have happened several times. For the others, it is not known whether the emergency indications were due to inappropriate use of the emergency switch by the user, or to data collection system malfunctions.

The magazine indicators are manually controlled by the operator of the surface parts truck. Use of them during the survey seems not to have been consistent. There are many weeks for which no magazine indications were recorded at all. At other times the "clear all magazines" shows up repeatedly but with no indications that the magazines were ever entered.

Of particular interest are the "bed up" and "bed down" indications for the four dump trucks. The original hydraulic

pressure actuated switches installed to signal these functions did not work. As a result, few indications were recorded during the first four months of the survey. In June, these were replaced with mechanically operated microswitches with feeler arms making direct contact with the dump bed when in the down position. Beginning July 12, regular bed up and bed down indications were recorded up to the end of the survey. These are summarized in Table 4-5 and compared with the logs kept by the drivers. Ideally, the three sets of figures should be the same, assuming that the driver raises and lowers the bed once for each trip between working face and crusher. Why there is disagreement is not understood. It can be seen from the totals that records of bed down, averaged over a period of time, came closer to logged trips than the records of bed up.

Table 4-5. Comparison of “bed-up” and bed-down records.

DATE	TRUCKS REPORTING	BED-UP	BED-DOWN	TRUCK TRIPS LOGGED
7/12	4	96	102	130
7/13	4	98	115	97
7/14	4	154	166	153
7/15	4	145	154	—
7/16	3	123	136	—
7/19	2 +	47	47	—
7/20	3	122	156	—
7/21	4	163	164	—
7/22	4	135	142	—
7/23	4	131	139	129
7/26	4	138	142	153
7/27	4	117	129	129
7/28	4	153	166	—
7/29	4	135	141	137
7/30	4	147	159	136
8/2	4	123	145	135
8/3	4	119	124	120
8/4	4	106	121	127
8/5	4	133	155	154
8/6	4	149	134	160
8/9	4	154	148	157
8/10	4	110	148	139
8/11	4	109	145	129
8/12	3 +	116	122	158
8/13	4	114	124	120
8/16	4	128	175	145
8/17	3	83	135	145
8/18	3	104	109	156
8/19	3	100	153	139
8/20	3	29	39	—
8/23	2 +	56	106	122
8/24	2	65	102	163
8/25	3	69	132	160
8/26	3	58	120	119
8/27	3	84	153	158

5.0 CONCLUSIONS RELATIVE TO SYSTEM UTILIZATION

This section addresses the nine questions, listed in Section 1.0, which the project is intended to answer. The questions are repeated below.

1. What are the telecommunications needs of this mine?
2. How does this system fulfill those needs?
3. What system alterations would better meet those needs?
4. How does the mine utilize the current system?
5. How could system utilization be improved?
6. Who uses (or doesn't use) the telecommunications system?
7. Of what cost/benefit is the telecommunications system to the mine? Discuss specific benefits and costs.
8. How does this system configuration compare against other methods of meeting the mine's needs (leaky feeder, for example) in terms of:
 - a. Technical feasibility?
 - b. Cost?
 - c. Reliability?
 - d. Cost/benefit?
9. How does the mine radio traffic look on a histogrammic basis?

Each question is addressed in order in the paragraphs that follow.

5.1 Telecommunications Needs of the Mine

5.1.1 Unscheduled Maintenance and Repair

Mr. Ken Reiser, General Manager, and Mr. Bob Kuehneman, Manager of Underground Operations, both concurred that the most obvious need satisfied by the radio system is the reduction of time required for unscheduled maintenance and repairs. The importance of communications in unscheduled maintenance and repair is made obvious from the record of production stoppages that occurred during the period covered by the project. This information is shown in Tables 5-1 and 5-2. Both tables show all gaps in the production of crushed limestone exceeding 15 minutes as recorded on the circular chart recorder actuated by the

**Table 5-1. Production outages and effect on radio usage—
March 29 through June 11, 1982**

DATE	OUTAGE DURATION	TIME BLOCKS AFFECTED	TIME BLOCK OCCUPANCY (SECS.)	AVERAGE OCCUPANCY (SECS.)	PERCENT ABOVE (BELOW) AVERAGE
4/1	20 m	9	361	143	152
4/2	25 m	13	387	132	193
4/5	30 m	12	135	114	18
4/6	25 m	10	351	120	192
4/7	15 m	12	257	114	125
4/8	1 h 35 m	13	70	132	(47)
		14	173	120	44
		15	19	53	(64)
4/12	15 m	10	133	120	11
4/13	25 m	11	156	127	22
4/19	15 m	13	NO DATA	132	—
4/20	15 m	12	NO DATA	114	—
4/23	1 h 00 m	10	168	120	40
4/27	33 m	10	60	120	(50)
		11	72	127	(43)
4/28	3 h 40 m	11	168	127	32
		12	175	114	54
		13	73	132	(45)
		14	58	120	(52)
		15	0	53	(100)
4/29	2 h 35 m	13	248	132	88
		14	22	120	(82)
		15	0	53	(100)
4/30	45 m	9	161	143	13
		10	164	120	37
5/6	15 m	10	22	120	(82)
5/10	32 m	13	139	132	5
5/12	28 m	12	INVALID DATA	114	—
		13	INVALID DATA	132	—
5/17	20 m	9	NO DATA	143	—
5/19	4 h 00 m	8	NO DATA	121	—
		9	NO DATA	143	—
		10	NO DATA	120	—
		11	NO DATA	127	—
		12	NO DATA	114	—
5/21	23 m	10	NO DATA	120	—
5/24	17 m	12	NO DATA	114	—
5/25	28 m	10	178	120	48
		11	72	127	(43)
6/1	15 m	13	141	132	7
6/8	1 h 40 m	8	INVALID DATA	121	—
		9	INVALID DATA	143	—
		10	INVALID DATA	120	—
6/8	1 h 4 m	12	INVALID DATA	114	—
		13	INVALID DATA	132	—

**Table 5-2. Production outages and effect on radio usage—
June 14 through August 27, 1982.**

DATE	OUTAGE DURATION	CAUSE	TIME BLOCKS AFFECTED	TIME BLOCK OCCUPANCY	AVERAGE OCCUPANCY	PERCENT ABOVE (BELOW) AVERAGE
6/14	1 h 52 m	SPLICE P-2	12	80	114	(30)
			13	124	132	(6)
6/24	30 m	BROKEN HYD, HOSE, #2 CURSHER	15	49	53	(8)
6/25	30 m	BOULDER #2 CRUSHER	9	213	143	49
7/2	45 m	SKIRT BOARD, 1/2 WAY	9	13	143	(91)
			10	11	120	(91)
7/6	15 m	E STOP TROUBLE	11	249	127	96
7/7	22 m	E STOP	10	289	120	141
7/8	20 m	E STOP	11	284	127	124
7/8	18 m	E STOP	14	174	120	45
7/12	2 h 30 m	CAR OFF TRACK/ELECT. TROUBLE 205 BELT	13	93	132	(24)
			14	88	120	(27)
			15	39	53	(26)
7/13	2 h 35 m	SPLICE 205 BELT	8	81	121	(33)
			9	150	143	5
			10	106	120	(12)
7/13	45 m	SKIRT BOARD, 1/2 WAY	11	156	127	23
			12	66	114	(42)
7/19	1 h 8 m	ELECT. 205	9	171	143	20
			10	336	120	180
7/19	2 h 00 m	ELECT. TROUBLE OUTSIDE	13	182	132	38
			14	107	120	(11)
			15	26	53	51
7/26	27 m	PLUGGED CHUTE	9	150	143	5
			10	88	120	27
7/27	25 m	?	8	73	121	(40)
7/27	1 h 30 m	PLUGGED CHUTE, 205 BELT WON'T START	13	141	132	7
			14	225	120	88
7/28	25 m	BOTTOM SLOPE BELT OFF	13	199	132	51
7/29	1 h 40 m	ELECT. PILOT LIGHT	8	246	121	103
			9	288	143	101
7/29	20 m	2-100 FUSES, 1/2 WAY	11	255	127	101
			12	203	114	78
7/29	40 m	2-100 FUSES, 1/2 WAY	14	113	120	(6)
7/30	35 m	P-5 RIP	12	61	114	(46)
8/2	35 m	P-5 OVERLOAD	9	108	143	24
			10	258	120	115
8/2	38 m	205 BELT	11	189	127	49
8/2	10 m	BELTS, #2 CRUSHER	12	122	114	7

**Table 5-2. Production outages and effect on radio usage—
June 14 through August 27, 1982 (continued).**

DATE	OUTAGE DURATION	CAUSE	TIME BLOCKS AFFECTED	TIME BLOCK OCCUPANCY	AVERAGE OCCUPANCY	PERCENT ABOVE (BELOW) AVERAGE
8/3	2 h 30 m	LOWER SLOPE, PLANNED OUTAGE	13	389	132	195
			14	165	120	38
			15	26	53	(51)
8/4	50 m	TAKE UP, 1/2 WAY	8	93	121	(23)
			9	94	143	34
8/4	15 m	BOULDER BREAKER TRIP	10	133	120	11
8/5	30 m	POWER OFF—STORM	8	114	121	(6)
8/6	30 m	—	8	114	121	(6)
8/9	1 h 5 m	BRAKE CAR BRAKES ELECT. OFF	8	98	121	(19)
			9	175	143	22
8/11	25 m	STOP-UP UNDER CRUSHER	10	253	120	111
8/12	15 m	LOADER—AIR TIRES	8	80	121	(34)
8/12	1 h 38 m	OUT OF ROCK	14	68	120	(43)
			15	42	53	(21)
8/12	1 h 00 m	OUT OF ROCK	14	209	120	74
			15	9	53	(83)
8/16	20 m	CHECK 1/2 WAY DRIVE	10	172	120	43
			11	274	127	157
8/19	50 m	BOTH CRUSHERS DOWN	13	195	132	48
			14	101	120	(16)
8/19	30 m	P-5 OVERLOAD	15	37	53	(30)
8/20	1 h 40 m	ELECT. TROUBLE 2-102	8	209	121	73
			9	294	143	106
			10	118	120	(2)
8/20	4 h 25 m	2-102 (205) PULLED IN TWO	11	158	127	24
			12	24	114	(80)
			13	90	132	(32)
			14	65	120	(46)
			15	8	53	(85)
8/26	20 m	CRUSHER STOP-UP	11	362	127	185
			12	263	114	131
8/26	1 h 20 m	LOWER SLOPE BELT BAD SPLICE	14	118	120	(2)
			15	60	53	13

haulage belt span scale at the mine entrance. Table 5-1 covers the period from March 18, 1982 to June 11, 1982. No record was made during this period of the causes of the gaps in production. Beginning June 14, 1982, the circular chart recordings were annotated with information accounting for the stoppages. This information is noted in Table 5-2 exactly as written on the circular charts. The following may help in interpreting some of the comments.

"P-1", "205", and "2-102" refer to specific haulage belts.

"Boulder in crusher" indicates that crusher operation is stopped because the chute is blocked by a piece or pieces of limestone too big for the crusher to handle.

"Plugged chute" indicates blockage of a chute at a haulage belt transfer point.

The "skirt board" is a part of the chute that diverts the crushed limestone onto the second belt.

The "E stop" is an emergency belt stoppage, usually triggered automatically by a fault in the haulage belt system.

"1/2 way" is the half way point on the slope entrance at which a radio equipped safety monitor is stationed. This is a transfer point in the slope haulage belt.

Both tables show the time blocks (i.e., the one-hour periods beginning at the time indicated) affected by the stoppage, the actual time block occupancy on the date of the stoppage, the average occupancy for the time block, and the percentage of time the actual occupancy exceeds the average. "Average" occupancy is based on the traffic recorded over a two-month period beginning May 1 and ending July 1, 1982. These figures are the subject of a later discussion.

Of the 127 work days included in the project (February 29 to August 27, 1982), stoppages of 15 minutes or longer are seen to occur on 68 days. Most (69%) were under one hour. It is likely that the duration of these stoppages would run much longer without adequate communications.

5.1.2 Safety

The enhancement of mine safety is a need perhaps more important than all others although more difficult to evaluate in terms of economics. One need is for minewide notification and instruction in case of fire or other emergency requiring evacuation of the mine. Another need is for accident reporting (which could apply to equipment or persons). In some cases, machinery or moving equipment may be involved, such as the haulage belts or the slope car, which is controlled from a point remote from the accident. There may be a need in these cases to

get the equipment stopped before further damage occurs. When persons are injured, there is a need to summon first aid and to arrange for speedy removal from the mine.

5.1.3 Supervision and Coordination of Production

Excluding the needs of safety and equipment maintenance, there remains a need for communications in the routine supervision and coordination of production. This is true because production activities (1) require a high degree of coordination, and (2) are spread out over too large an area to permit coordination without some form of radio or telephone communications. Most communications by the production foreman, the equipment operators, truck drivers, powder crew, driller, etc., are considered to be associated with routine production activities.

5.2 How the System Fulfills the Needs

The radio system provides complete coverage throughout the active part of the mine as well as above ground all the way to the line plant and parts warehouse. When equipment break downs occur, time is saved by radio reporting and by the use of radio in replacement parts retrieval.

Safety is improved by the ability to contact all personnel almost instantaneously in case of fire or other emergency requiring evacuation of the mine. Specific instructions can be issued, for example, on whether to evacuate via the entrance slope or the air shaft. Safety is also improved by the provision of direct communications between the slope car and hoist operator. The hoist operator can be directed to stop or start the car at anytime from the car itself. Radio communications is also used to report accidents and speed up evacuation of injured person(s). It does this by summoning transportation for the injured party and arranging to have him met by the slope car when he arrives at the bottom of the slope.

In routine production, the radio system permits supervisory and coordinating communications among the individuals involved. It is particularly useful in communicating with moving vehicles, such as the trucks, for which telephones are not convenient.

5.3 System Alterations

The subject of system alterations that would better meet the needs of the mine is covered in Section 8.0, Recommendations.

5.4 How the Mine Utilizes the System

The communications needs of the mine are fulfilled by two systems: the radio system and the Femco telephone system. Telephones are located at the hoist house, the half-way station,

bottom of the slope, the air shaft, the crushers, and the shop area.

The use of communications in a typical unscheduled maintenance situation, such as a haulage belt break, is illustrated in Figure 5-1. The trouble is likely to be first observed by the crusher operator, the conveyor or the half-way observer. The crusher operator would normally report the problem via the Femco telephone at his work station. The conveyor, because he roams, would find it more convenient to report by radio. The half-way observer could use either, but typically uses radio.

The radio is also used to save time in maintenance activities other than those resulting from major production stoppages. For example, quoting from Reference 3:

Interviews were conducted with key mine personnel who use the new radio and CCTV systems on a regular basis. Mr. William Day, Underground Maintenance Coordinator, declared he saved about two hours per day locating maintenance people by using the radio system. Prior to the implementation of the radio system, he was required to walk or when possible drive throughout the mine to locate the person or persons needed. Also when the telephone system is busy, the radio system provides them with back up communications.

Another expensive savings has been realized when mine equipment breaks down. The miners can call the maintenance people using the radio system and describe in some detail what the problem is before the maintenance man is dispatched. The maintenance man can then take the tools and parts required instead of making two trips.

Also, quoting from Reference 3:

Mr. Dick Wehrmeyer, Electrical Engineer, indicated a time savings in locating the day shift electrician who could be in any part of the mine area underground or above ground. He can be reached on the radio system, speak directly to the person reporting the problem saving trips into and out of the mine.

Quotations from Reference 3 also indicate how radio communications has been used to improve mine safety.

Mr. Benny Whitmer, Safety Supervisor, stated that the mine has two fire drills per year for everyone in the mine. The radio system has

MAJOR PRODUCTION STOPPAGE

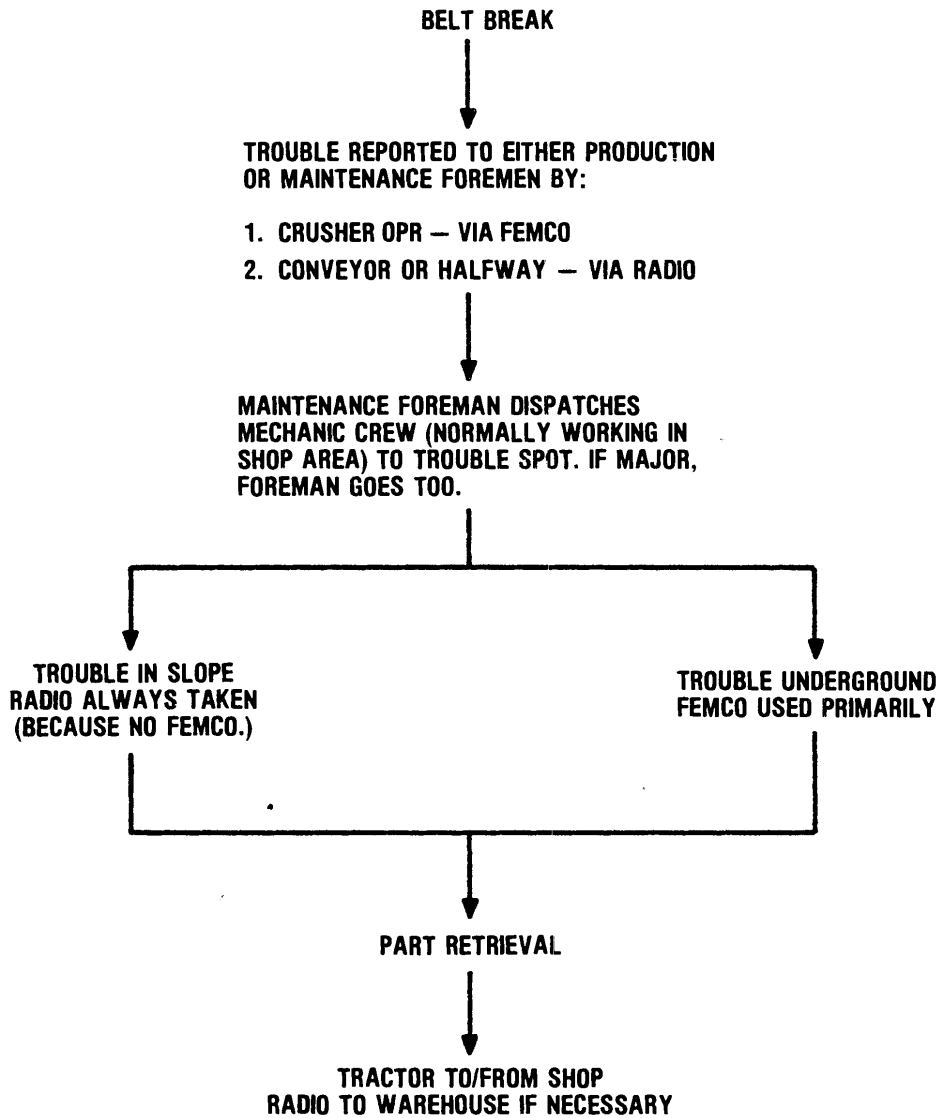

Figure 5-1. Procedure used for major production stoppage.

reduced the time for these drills from 30 minutes to 12 minutes. In addition to the obvious improvement in response time the side benefit was a reduction in payroll costs for the fire drills for 40 men at an average of \$7.00 per hour using 12 minutes instead of 30 minutes for the fire drills. He also said the radio system could cut considerable time in getting an injured man out of the mine and into a hospital.

He also commented on the safety value of the radio system and CCTV system concerning the slope car, the two way speech to the winch operator and the TV coverage at the foot of the slope. When he is in his office above ground he monitors all three channels of the radio system on three different speakers, giving him the jump on any emergencies. One man smashed his hand, used his emergency call and was helped immediately.

The usefulness of the radio in the slope is further emphasized by the hoist house (winch) operator as follows:

The hoist house operator, who is the designated monitor of slope activity, stated that using the radio system for voice communication provides a whole new gamut of stops for the slope car that were not possible before. This is because he is able to maintain continuous and immediate communication with personnel in the slope car and can make unscheduled stops.

The radio system is vital when they are lowering large equipment into the mine down the slope. They have much more control to stop or start preventing damage to equipment or cables and reducing danger to support people.

One fire drill was held during the period of the survey. The drill was initiated at 9:34:18.9 AM on March 2, 1982 and ended 20 minutes and 21.7 seconds later. During this period the Maintenance Foreman came on the air 14 times for a total of 49.7 seconds. The Safety Director used his radio 4 times for a total of 9.9 seconds. The only other voice activity was the half-way monitor who talked twice for a total of 6.3 seconds. Total occupancy for the one hour time block was 334 seconds, indicating that activity during the remaining part of the hour was much greater than during the fire drill.

There are fewer specifics on the use of radio for the supervision and coordination of routine production. This is partly because the advantage of radio over the Femco telephone system is not as great in situations that are predictable and

routine. Telephones are provided at all regular work stations and locating a person away from his work station usually is less urgent. However, the radio is used in production related activities as is discussed in Section 5.6.

5.5 How Utilization Could Be Improved

This subject is covered in Section 8.0, "Recommendations."

5.6 Who Uses the Telecommunications System

Reference back to Table 4-4 reveals which ID equipped radios were used to initiate messages, or more specifically, the number of times the normal push-to-talk button was pressed. An assumption is made that the person using the radio is the one listed. This is believed to be accurate with respect to mobile units permanently attached to the vehicle with which it is used. Persons assigned portable radios are understood to have used the radios assigned for the most part. However, no accurate records were kept as to when a spare unit may have been temporarily substituted for one regularly assigned, or if and when, radios may have been "swapped" for any reason.

Table 4-4 shows that the person making the most use of radio is the Maintenance Foreman (Mr. Johnny Jones, using ID #001). The table shows that his radio accounts for 22.6% of the total activity for the six month period, even though it was barely used during four weeks in July and August. During the same four weeks, the use of the spare radio (ID #010) jumps to a level of use comparable to ID #001 preceeding and after the four week period. If it can be assumed that the spare radio was in fact used for the maintenance function, the percentage of use assigned to this function would be 25.3%.

After maintenance, radio users are ranked as follows:

Half-way	9.4%
Electrician	7.2%
Spare	6.4%
Conveyor	6.2%
Surface parts truck	5.6%
Powder crew	5.0%
Foreman #2	4.9% (used mostly as a spare)
Mr. Kuehneman	4.2%
Foreman #1	4.0%
Truck #10	3.9%
Safety Director	3.5%
Water truck	3.1%
Lime plant	2.6%
Engineering	2.5%
Truck #9	2.5%
Truck #11	2.3%
Slope car	2.2%
Radio maintenance	0.8%

Truck #8	0.7%
Scaler	0.12%
5 Loaders	0.07%

No usage was recorded for the Jumbo Drill. No usage was recorded for the slope car for the final eight weeks of the survey, although traffic was recorded on channel #5 which is used exclusively by the slope car. This could be due to a failure of the MODATS ID on the slope car radio.

It is of interest to break down radio usage by the three functions previously discussed: maintenance, safety and production. It is not likely that any one individual is exclusively concerned with any one of these functions. However, it is estimated that the following are primarily concerned with maintaining mine equipment, detecting malfunctions (i.e., monitoring belts, etc.), and making repairs as expeditiously as possible when breakdowns occur.

- Maintenance Foreman
- Lime Plant
- Engineering (40%)
- Radio Maintenance
- Conveyor
- Mr. Kuehneman (40%)
- Half-way (50%)
- Slope car (50%)
- Surface parts truck (50%)

These, at the percentages indicated, would account for 50% of all the activity.

All mining personnel are, or should be concerned with safety. The only ones identified whose primary responsibility is safety, however, are the Safety Director and the half-way monitor. The latter also monitors the slope haulage belt, so that his radio activity is assumed to deal 50% with maintenance and 50% with slope safety. Safety routinely accounts for about 8% of the radio activity. In an emergency, it would obviously account for much more. The value of radio for safety purposes is that it is there when needed. The remainder of the radio activity, about 42% would be that used to support routine production activities. This would include both supervisory activities and communications between persons engaged in production.

5.7 Cost Benefit

The costs versus benefits of the radio system is the subject of Section 6.0, following.

5.8 How the System Configuration
Compares With Other Methods

The comparison of the radio system configuration with other methods of meeting the mine's needs is the subject of Section 7.0, following.

5.9 Radio Traffic Histograms

Histograms of radio traffic for all three channels shown in hourly time blocks are contained in Appendix A. The daily peaks and the time blocks in which they occur are extracted in Table 4-3.

6.0 COST BENEFIT

Mine management plans to continue the radio system after the financial support of the U.S. Bureau of Mines is terminated. Management believes that the system is justified by the reduction of down time for unscheduled (or unanticipated) maintenance and repairs.

6.1 Mine Revenue

The mine was, during the period of the survey, operating at less than its full capacity. Even so, its average output of crushed limestone was about 683 tons per hour during the 8:30 AM to 3:30 PM* period of active production. The value of a ton of crushed limestone at the mine portal is about \$2.65. Any interruption in this production, such as a break in a haulage belt, cost the mine \$1,810 per hour because of the loss of product with no compensating saving in operating cost.

6.2 Loss in Revenue From Production Stoppage

Tables 5-1 and 5-2, previously referred to, show 68 production stoppages for periods of 15 minutes or more during the period of the survey. The total time lost during the six month period was approximately 63 hours. This, of course, is the production loss with radio. If the radio were not in use, it would take longer to locate and dispatch maintenance personnel. Often, without two-way communications allowing questions and answers, it would be necessary for the maintenance man to make two trips, once to inspect the problem area and a return trip to bring the right tools and parts. More time would be lost if a part were required from the parts warehouse on the surface. Assuming that radio communications saves an average of 30 minutes in getting the system back in operation after each unscheduled stoppage, mine revenue would be increased by

$$2 \times 68 \text{ stoppages per 6 mo. period} \times 0.5 \text{ hr} \times \$1810 \\ = \$123,080 \text{ per year.}$$

6.3 Savings in Supervision and Coordination, Production

Production operations, although highly interdependent, are spread out over a considerable area. Close coordination is required between working face and crushers, and between crushers and the haulage belt system which extends out of the mine all the way to the lime plant. Radio puts the production foreman in immediate contact with all key personnel at all locations. He is relieved of having to personally be at all locations where his supervision extends. Without radio, it is estimated that one additional lead person would be required to assist in maintaining

*Based on production records for July and August, 1982.

supervisory control over activities at widely separated location. The cost to the mine of such a person (with employee benefits and overhead expenses) is estimated as \$30,000 per year.

6.4 Cost of the Radio System

The initial cost of the radio system was, by Reference 3, \$600,000. It is usual to amortize such equipment over a period of 10 years. Allowing 12% as the cost of money, the annualized cost is \$106,190. This does not include maintenance. During the survey, the equipment was maintained by a full-time Motorola representative under a contract with the US Bureau of Mines. When the Bureau of Mines contract expires, mine management plans to continue service but under a "time and materials" arrangement with the Motorola Cincinnati office. It is assumed that at least two days, or 16 hours a week will be required at a rate of \$25 per hour. This multiplies out to \$20,800 per year. In addition, two round trips a week out of the Cincinnati office will, at \$0.25 a mile, add another \$40 per week of cost. The estimated annual cost of maintenance is therefore:

Maintenance labor	\$20,800
Travel (52 X \$40)	<u>2,080</u>
	\$22,880

Adding this to the annual equipment and installation costs:

Annual equipment cost	\$106,190
Maintenance cost	<u>22,880</u>
Annual cost of radio system	\$129,070

6.5 Benefits vs Costs

The two benefits identified are the reduction of production losses to unscheduled stoppages and a saving in labor cost by more efficient supervision and coordination. Estimated savings from these two are:

Reduction of production losses	\$123,080
Savings in supervision & coordination	<u>30,000</u>
	\$153,080

There are other benefits more difficult to quantify. These include added safety and the reduction of time needed to remove injured personnel. The reduction in time needed to evacuate the mine during a fire drill, for example, will save a small amount of production time each year, but in a real emergency could result in the saving of lives.

The benefits can be compared with the estimated cost of \$129,070 per year. To the extent that benefits are greater than the cost, the radio system is economically justified. If a second, production shift were added, the benefit would increase proportionately with small increase in cost.

It should be borne in mind that the radio system is one of two communications systems used in the mine and that the functions of the two overlap to a large degree. Without either system, it is unlikely that the mine would operate at all. The benefits of having at least one system of communications are therefore very great. There is a lesser benefit in adding a second system, although this benefit is greater for radio than for telephones. As previously noted, radio allows communication with moving vehicles and allows a radio equipped individual to communicate from any point.

Benefits of the radio system would be greater if the MODATS reporting system were made to work better. There is no basic reason why the bed-up and down indications could not be made to work more reliably and used as a measure of production. The erratic surface parts truck indications with respect to its presence in the magazines could possibly be improved by making them automatic - not requiring any action by the driver. These matters are more fully covered in Section 8.0.

7.0 COMPARISON WITH OTHER METHODS OF MEETING THE MINE'S NEEDS

The present communications needs of the mine are being satisfied by both the radio system and a Femco telephone system. They are often used interchangeably and one serves as a backup to the other. The radio has an advantage in communications with moving vehicles and roving personnel when not near a telephone station. A requirement of the radio system is that it provide complete coverage of at least the active areas of the mine and of the surface in the vicinity of the outside haulage belt system, the lime plant and the parts warehouse. The system in use was carefully engineered to perform these functions.

7.1 Leaky Feeder

The only other similar (UHF) system that might do as well is one using "leaky feeder" cable. Reliability and technical feasibility should be the same. However, this was originally considered for Black River and ruled out in favor of a system using "distributed antennas" and strategically placed passive reflectors, as described in Section 2.0. The distributed antenna design made use of 2600 feet of 7/8 inch diameter coaxial cable and 9600 feet of 1/2 inch coaxial cable. Had leaky feeder been used, an equivalent length (12,200 feet) of leaky feeder cable would be required to cover the same area covered by the low loss cable network of the distributed antenna system. In addition, about 1800 feet of additional leaky feeder cable would be required for each antenna and passive reflector to fill in the crosscut tunnels (900 feet in each direction). There are 24 antennas and 27 reflectors. If each is replaced with 1800 feet of leaky feeder cable, 91,800 feet additional cable would be required. The 12,200 feet of trunk cable should be 7/8 inch diameter to keep losses to a minimum. The 91,000 feet of branching cable could be 1/2 inch in diameter. A comparison of material cost is as follows:

Present System

2600 ft. of 7/8" coax @ 4.05/ft	\$10,530
9600 ft. of 1/2" coax @ 1.55/ft	14,880
24 antennas @ 30	720
27 reflectors @ 20	540
TOTAL	\$26,670

Leaky Feeder

12,200 ft. of 7/8" Radiax @ 5.50	\$ 67,100
91,800 ft. of 1/2" Radiax @ 2.76	253,368
TOTAL	\$320,468

It is obvious that the use of distributed antenna systems combined with passive reflectors results in a considerable saving over an equivalent leaky feeder system for wide-area coverage of a room and pillar mine. Leaky feeder would find greater justification in covering long tunnels as opposed to

large two-dimensional areas.

7.2 MF Reradiation Systems

A traditional "trolley-wire" system would not have accomplished the objective of complete coverage. The transceivers would normally be able to operate only in close proximity to the specially installed conductor using a 24 inch elongated loop antenna. However, the Bureau of Mines has recently announced a "whole-mine medium frequency radio communication system" which if it performs as claimed, does provide mine-wide communications to both vehicles and roving personnel. The system operates in the range of 0.3 to 3 MHz and utilizes parasitic coupling onto and re-radiation from existing mine wiring to achieve the desired coverage. The personnel transceivers consist of radio modules distributed in the pockets of a special vest. A loop antenna is sewn into the back of the vest. Repeaters located at strategic points in the mine enhance signal strength very much as VHF and UHF repeaters do.

Insufficient information is currently available on the cost of the MF communication system to make a comparison. However, it is a system that merits further consideration for mine use.

8.0 RECOMMENDATIONS

8.1 Utilization of Truck Dump-Bed Data

Despite the inconsistencies shown in Table 4-5, in which "bed-up" and "bed-down" data are compared with logs kept by the drivers, there is no fundamental reason why such data cannot be used to provide a reliable record of production. Table 8-1 shows production figures that would have resulted if the data accumulated during the July 16 to August 27 period (the only period during which consistent bed-up and bed-down data was recorded) had been used for this purpose. Based on figures for July and August of 1982, the average load carried by a truck is 30.1 tons. Each bed-up or bed-down indication can therefore be assumed to represent 30.1 tons of limestone dumped into a crusher. This being the case, the bed-up figures would have fallen 19.5% short of the tonnage manually logged over the six week period. The bed-down figures would have fallen short by only 4.3%.

It is recommended that the method of providing a bed-up or bed-down indication be examined. Both are not needed if one can be trusted. We suggest the use of a pressure sensitive switch on the high side of the hydraulic cylinder to be actuated each time the dump bed is raised. The system should be thoroughly tested for both false indications and failure to provide true indications. It should be possible to achieve a very high degree of reliability and to provide an accurate record of production by this method.

Table 8-1. Production records from bed-up and bed-down indications.

WEEK ENDING	TONNAGE DETERMINED FROM				TONNAGE LOGGED
	BED-UP	% ERROR	BED-DOWN	% ERROR	
7/16	18,542	- 8.2	20,257	+ 0.1	20,228
7/23	18,000	- 19.0	19,505	- 12.2	22,213
7/30	20,769	- 8.3	22,184	- 2.1	22,651
8/6	18,963	- 7.4	20,438	- 0.2	20,488
8/13	18,150	- 14.3	20,679	- 2.4	21,179
8/20	13,364	- 22.6	18,391	+ 6.5	17,276
8/27	9,993	- 55.0	18,451	- 16.9	22,211
	117,781	- 19.5	139,905	- 4.3	146,246

8.2 Dispatching and Operating Procedures

Essential to effective operation and control is a dispatcher responsible for maintaining circuit discipline, keeping track of all radio equipped vehicles and personnel, and exercising control during drills and emergencies. There is currently no person fulfilling this role.

It is recommended that a dispatcher position be established and that standard operating procedures be developed. In an operation the size of Black River Limestone Company, the dispatcher could be a person with colateral duties, such as the hoist operator. Among the dispatcher's duties would be keeping track of which ID numbered portables had been issued and to what persons. He should know where each person is working and procedures should be established to keep this information updated. The dispatcher should be able in emergencies to disable (knock down) the repeaters and operate the system as a group of wire-line controlled base stations. This provides the dispatcher with total control of the radio system and eliminates chaotic person-to-person transmissions which only serve to confuse the emergency situation. It should be the procedure in drills and emergencies for each radio equipped person to report the locations and status of himself and others for whom he may be responsible.

8.3 Elimination of Channel #3

The total traffic on the radio system does not justify three channels. From the viewpoint of safety, it may be desirable to continue the use of channel #5 as a dedicated slope channel. However, channel #3 traffic could easily be combined with that on channel #1 with only a minor effect on the peak loadings recorded for channel #1. For one thing, the average peaks on channel #3 were only 21% of the average for channel #1. For another, the time blocks during which the peaks of the two channels occurred coincided only 21 times out of the 111 days for which valid data was available, i.e., the peaks add directly less than one time in five.

It is recommended that channel #3 be eliminated along with the three base/mobile repeaters, modems and voting modules associated with channel #3. The surface parts truck (ID #300) would shift its traffic over to channel #1. The equipment eliminated would go into the spares inventory. This action would reduce maintenance costs and eventual replacement costs. Future purchases of portable and mobile units need to specify only two channels. (Note: No data was taken on the "talk around" channels numbers 2, 4 and 6, but information furnished indicates that they were infrequently used.)

8.4 Magazine Entry Records

If information on the location of the surface parts truck with respect to the powder, dynamite and blasting cap magazines is important to safety, then the record of entry and exit from the magazines needs to be automated. The present system is unreliable. Each vehicle that enters a magazine could, for example, be equipped to detect the presence of a low power responder inside the magazine and immediately signal the dispatcher that the vehicle is at that location.

It is recommended that the automatic signalling of the presence of vehicles or persons at hazardous locations be made the subject of a future investigation.

REFERENCES

1. Chufo, R.L. & Vancura, P.D., "The Installation, Operation and Maintenance of an Underground Minewide Radio System" IEEE-IAS Conference Proceedings, Chicago, IL, Oct. 1976.
2. Cory, T.S., "Telephone Communication System for a Deep-Vein Metal Mine," Final Rpt. prepared for the US Bureau of Mines under Contract No. J0100093, March 1982.
3. Isberg, R.A., Kramer, H. & Parrish, D.A., "The Implementation of UHF Radio Communication and CCTV Monitoring Systems in a Room and Pillar Metal/Non-metal Mine," Final Rpt. prepared for the US Bureau of Mines under Contract No. J0377044, March, 1981.

APPENDIX A
HISTOGRAPHS

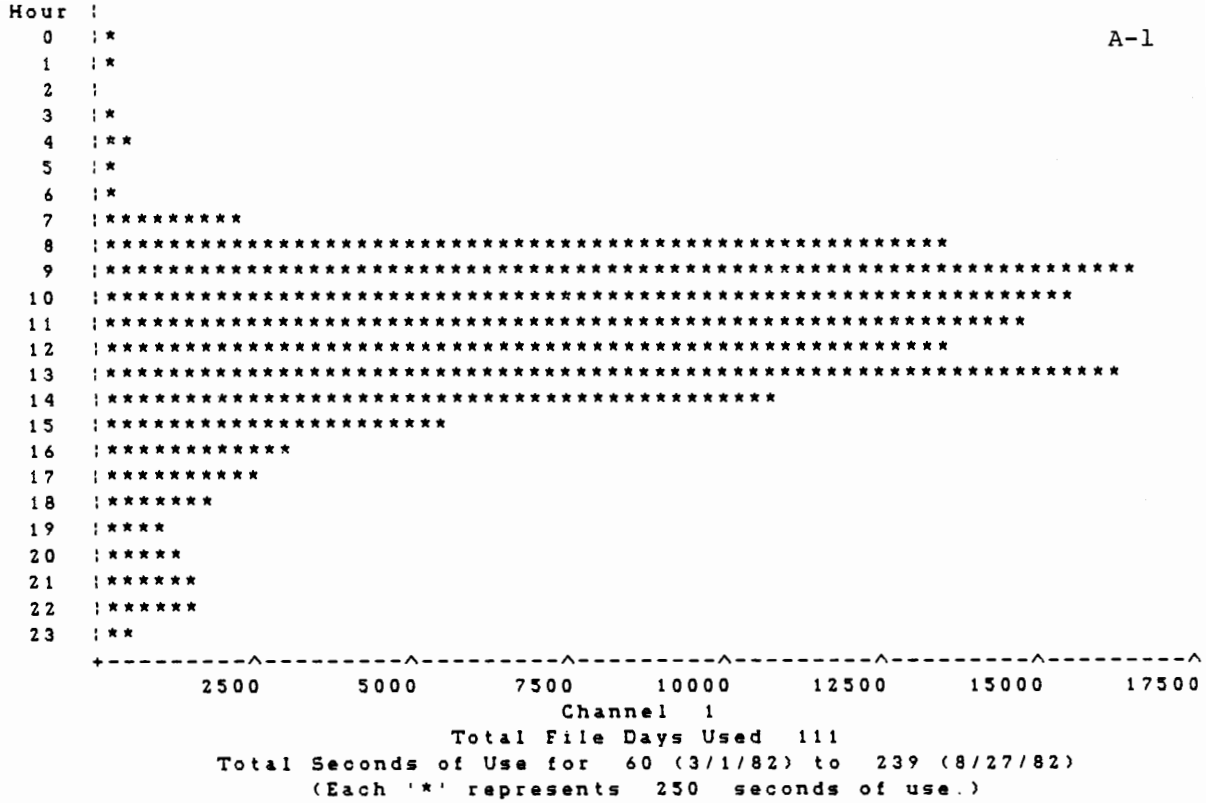

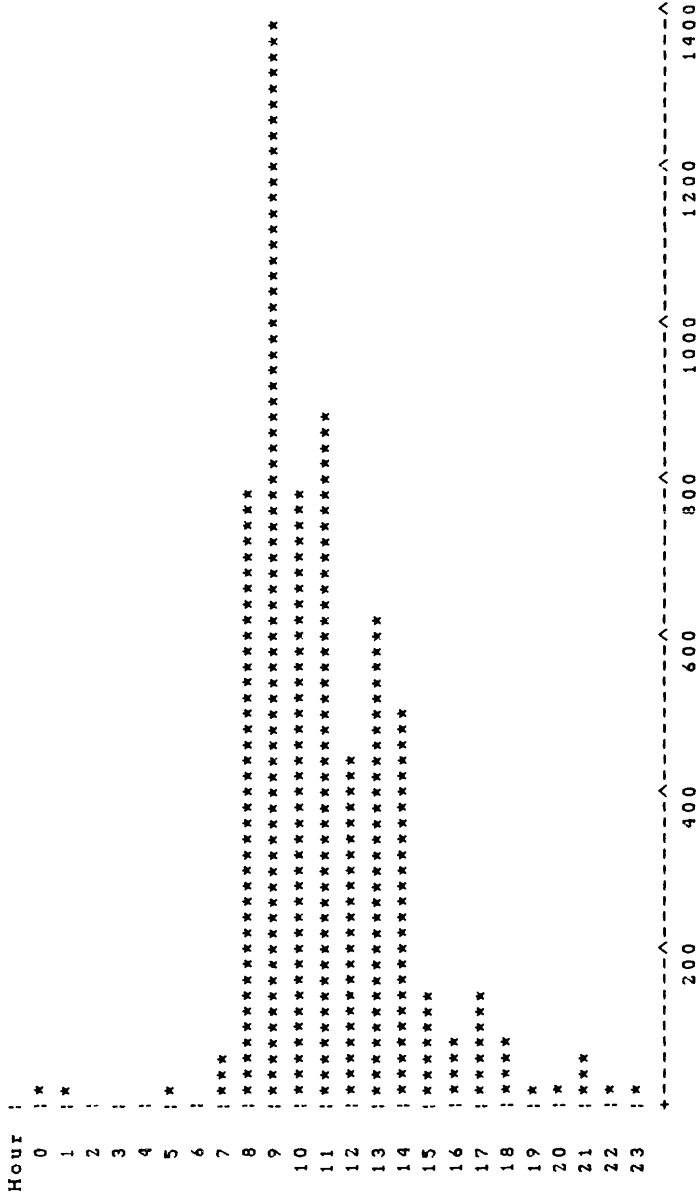
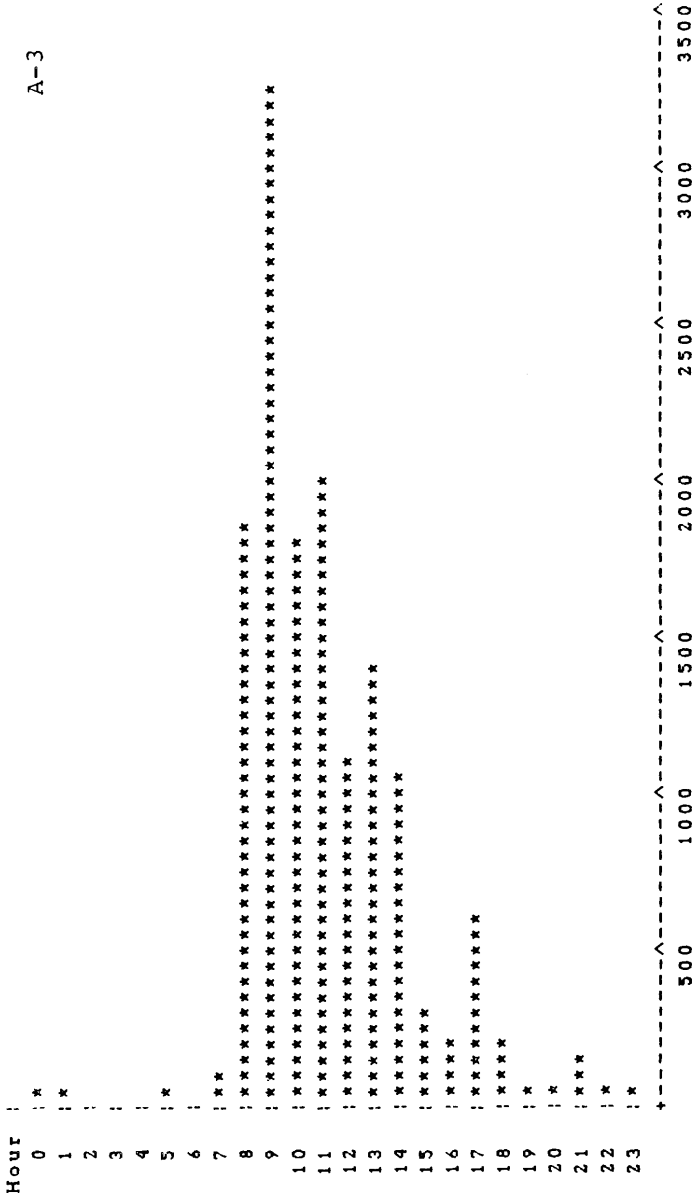

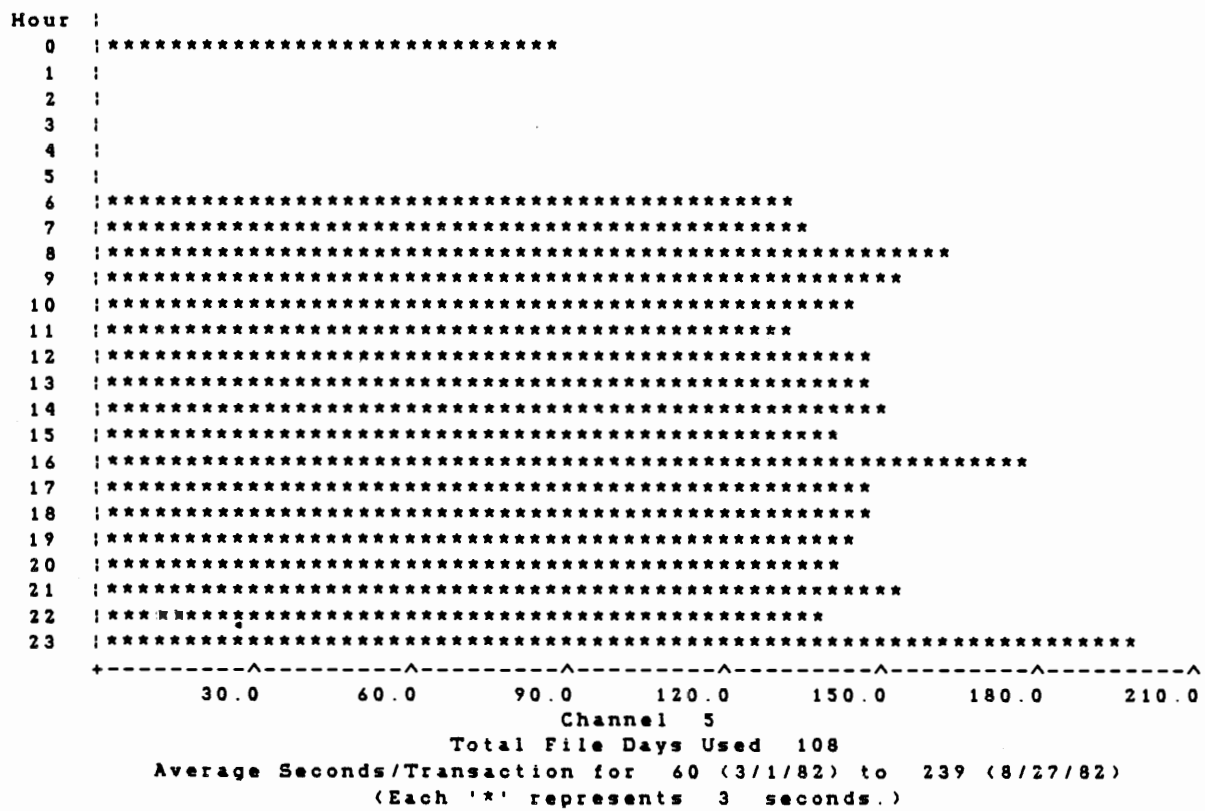
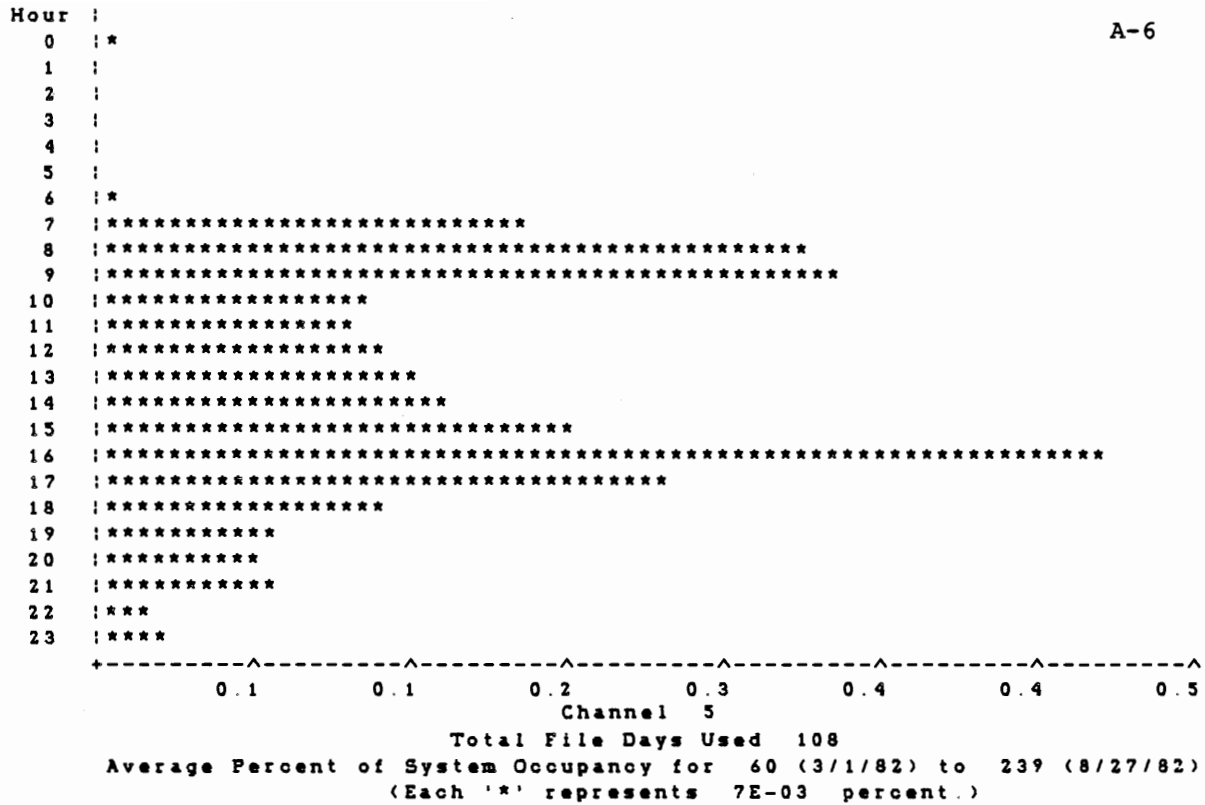



Channel 1
 Total File Days Used 23
 Total Seconds of Use for 60 (3/1/82) to 90 (3/31/82)
 (Each '*' represents 60 seconds of use.)

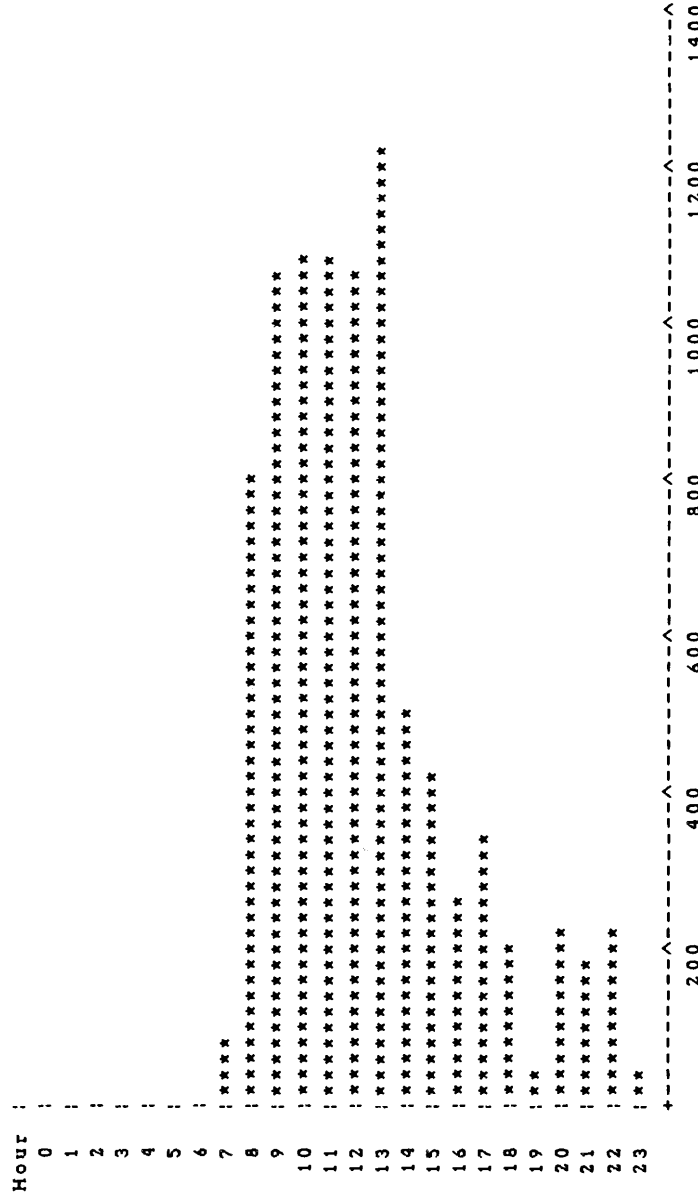

Channel 1
 Total File Days Used 23
 Total Transactions for 60 (3/1/82) to 90 (3/31/82)
 (Each '*' represents 20 transactions.)

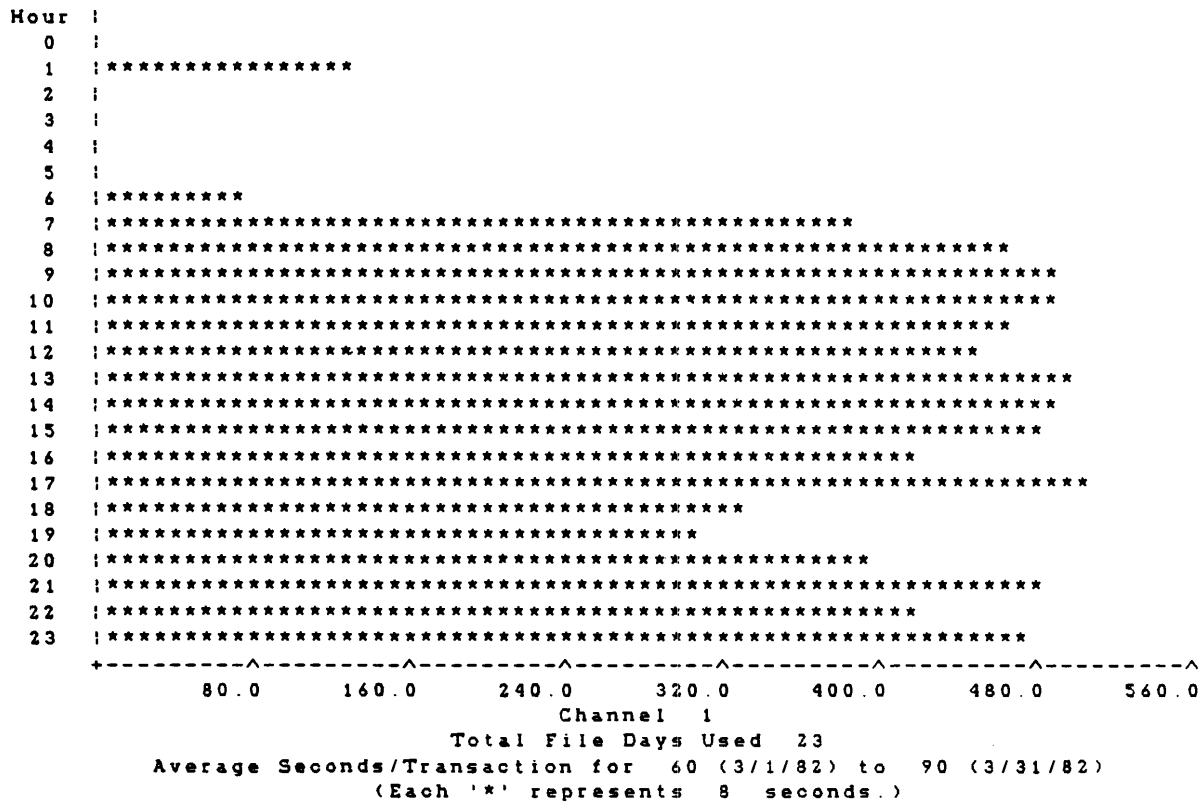
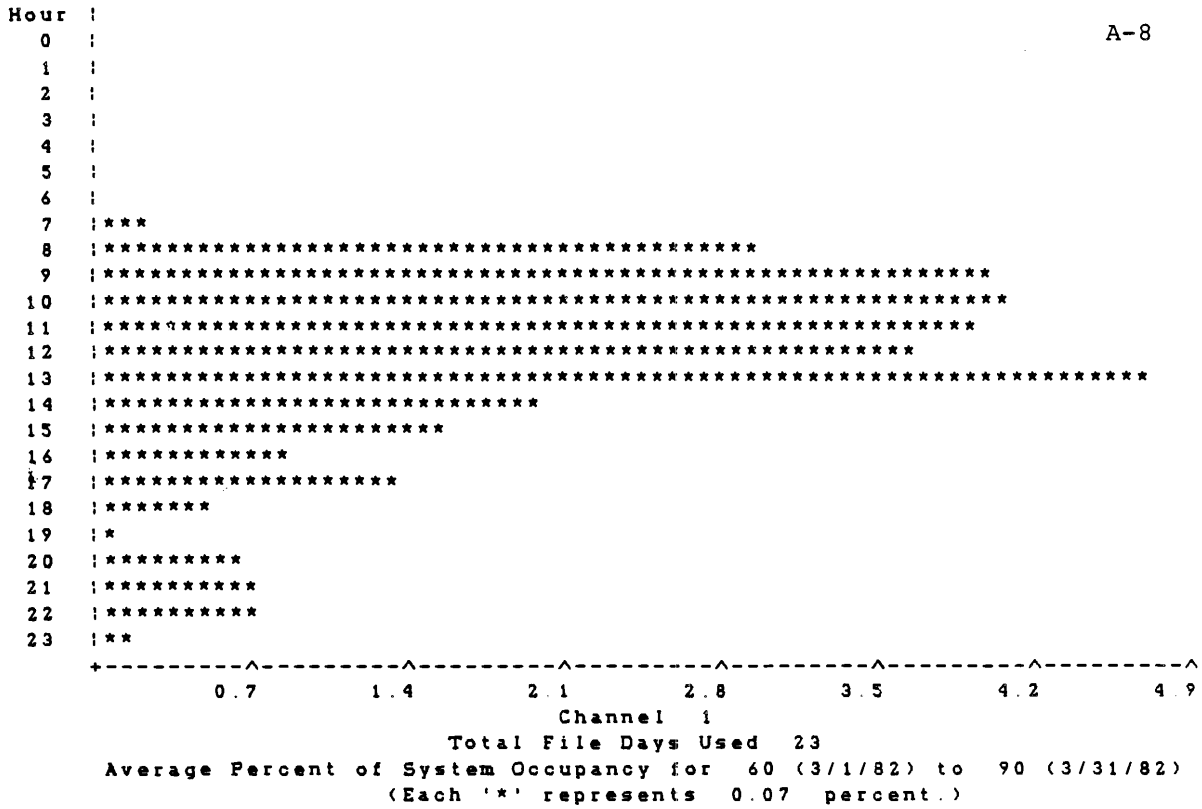

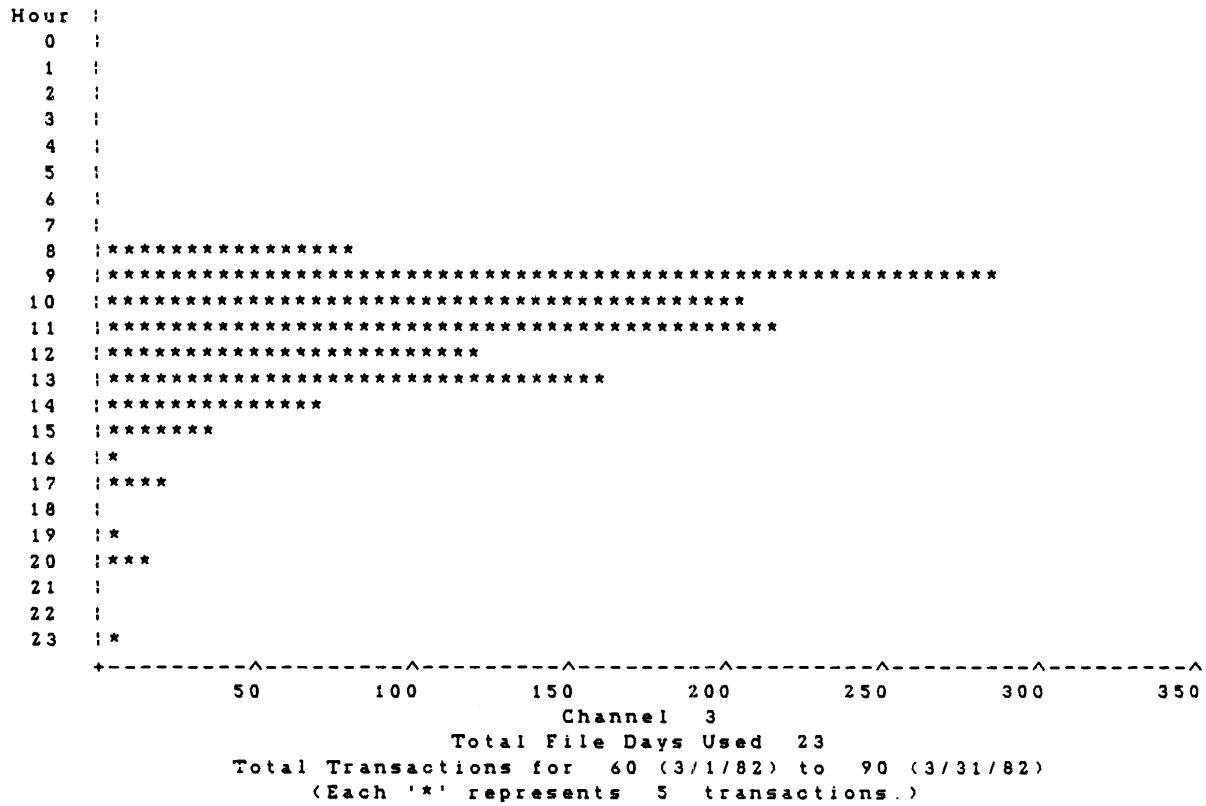
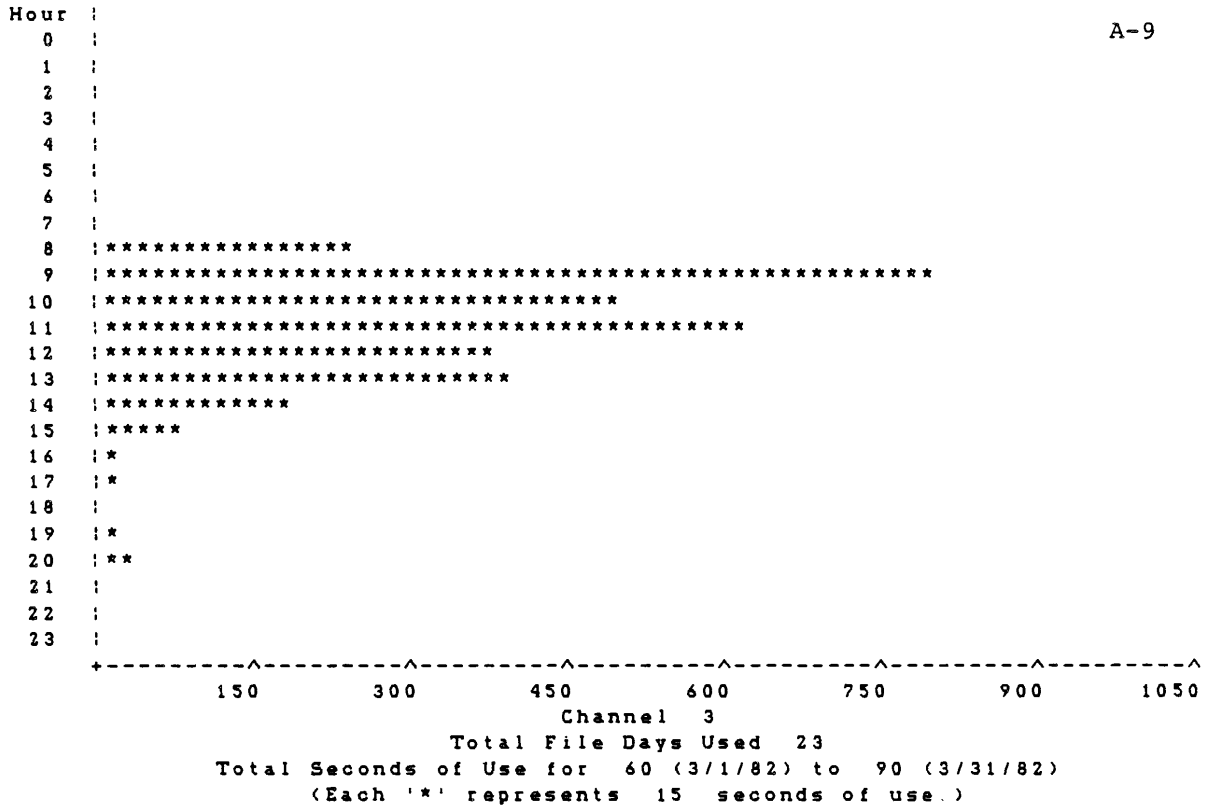

Hour	0.2	0.3	0.5	0.6	0.8	0.9	1.1
0							
1							
2							
3							
4							
5							
6							
7							
8	*****						
9	*****						
10	*****						
11	*****						
12	*****						
13	*****						
14	*****						
15	*****						
16	*						
17	*						
18							
19	*						
20	**						
21							
22							
23							

Channel 3
 Total File Days Used 23
 Average Percent of System Occupancy for 60 (3/1/82) to 90 (3/31/82)
 (Each '*' represents 0.015 percent.)

Hour	71.0	142.0	213.0	284.0	355.0	426.0	497.0
0							
1							
2							
3							
4							
5							
6							
7							
8	*****						
9	*****						
10	*****						
11	*****						
12	*****						
13	*****						
14	*****						
15	*****						
16	*****						
17	*****						
18	*****						
19	*****						
20	*****						
21	*****						
22	*****						
23	*****						

Channel 3
 Total File Days Used 23
 Average Seconds/Transaction for 60 (3/1/82) to 90 (3/31/82)
 (Each '*' represents 7.1 seconds.)

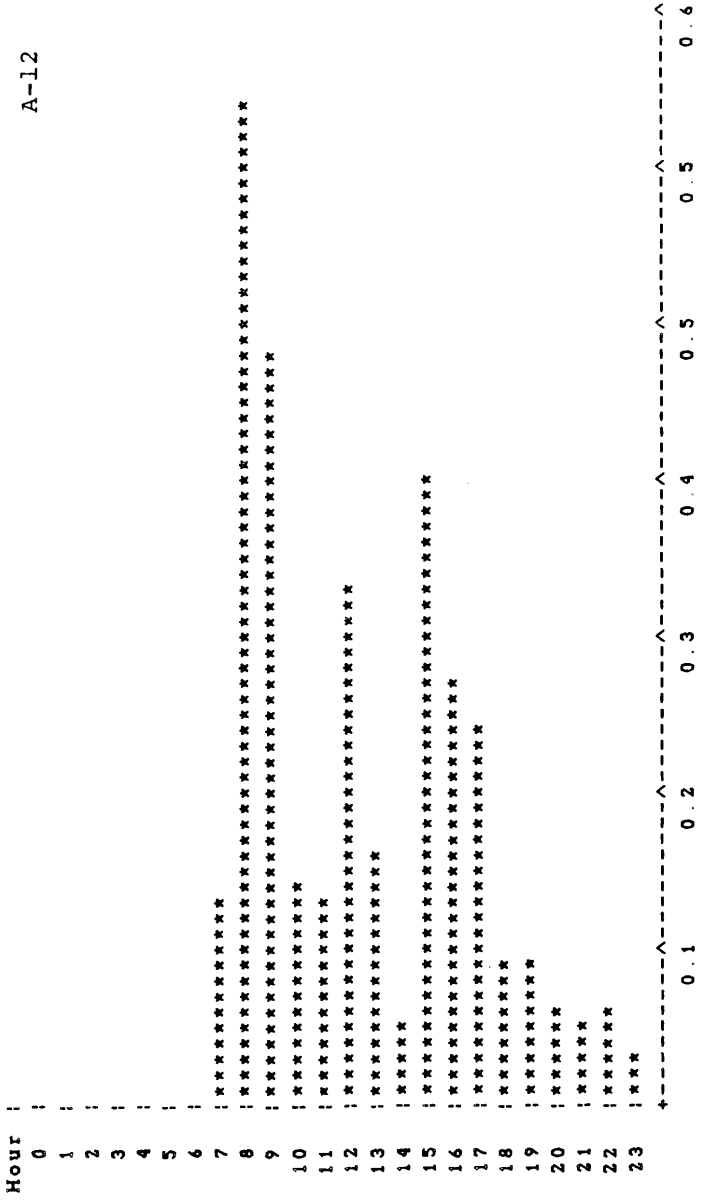

Channel 5
 Total File Days Used 23
 Average Percent of System Occupancy for 60 (3/1/82) to 90 (3/31/82)
 (Each 'x' represents 9E-03 percent.)

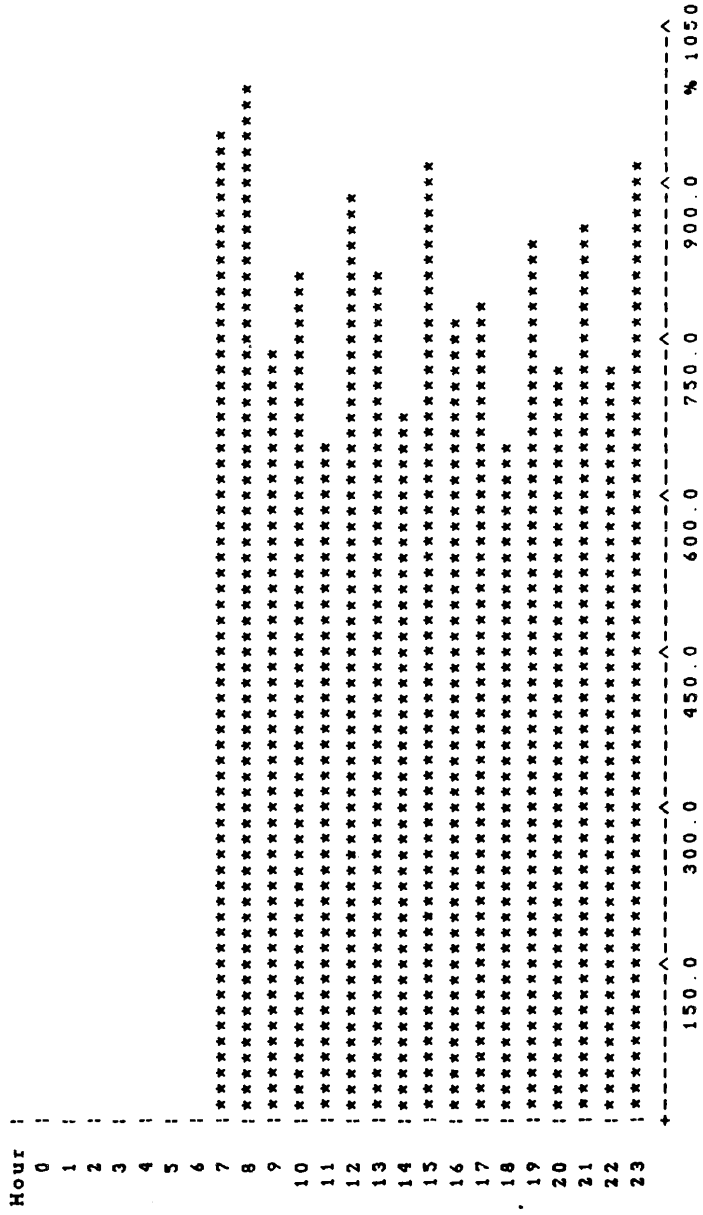

Channel S
 Total File Days Used 23
 Average Seconds/Transaction for 60 (3/1/82) to 90 (3/31/82)
 (Each 'x' represents 15 seconds.)

```

Hour |
0 | *
1 |
2 |
3 |
4 |
5 |
6 |
7 | **
8 | *****
9 | *****
10 | *****
11 | *****
12 | *****
13 | *****
14 | *****
15 | *
16 | **
17 | *****
18 | *****
19 |
20 | *
21 |
22 |
23 |
+-----+-----+-----+-----+-----+-----+-----+-----+-----+-----+
70 140 210 280 350 420 490
Channel 3
Total File Days Used 18
Total Seconds of Use for 91 (4/1/82) to 120 (4/30/82)
(Each '*' represents 7 seconds of use.)

```

```

Hour |
0 |
1 |
2 |
3 |
4 |
5 |
6 |
7 | **
8 | *****
9 | *****
10 | *****
11 | *****
12 | *****
13 | *****
14 | *****
15 | *
16 | *****
17 | *****
18 | *****
19 |
20 | *
21 | ***
22 |
23 |
+-----+-----+-----+-----+-----+-----+-----+-----+-----+-----+
30 60 90 120 150 180 210
Channel 3
Total File Days Used 18
Total Transactions for 91 (4/1/82) to 120 (4/30/82)
(Each '*' represents 3 transactions.)

```

Hour	250	500	750	1000	1250	1500	1750
0							
1							
2							
3							
4							
5							
6							
7	*	*	*	*	*	*	*
8	*	*	*	*	*	*	*
9	*	*	*	*	*	*	*
10	*	*	*	*	*	*	*
11	*	*	*	*	*	*	*
12	*	*	*	*	*	*	*
13	*	*	*	*	*	*	*
14	*	*	*	*	*	*	*
15	*	*	*	*	*	*	*
16	*	*	*	*	*	*	*
17	*	*	*	*	*	*	*
18							
19							
20	*	*	*	*	*	*	*
21	*	*	*	*	*	*	*
22	*	*	*	*	*	*	*
23							

Channel 1

Total File Days Used 9
Total Seconds of Use for 123 (5/3/82) to 148 (5/28/82)
(Each '*' represents 25 seconds of use.)

Hour	200	400	600	800	1000	1200	1400
0							
1							
2							
3							
4							
5							
6							
7	*	*	*	*	*	*	*
8	*	*	*	*	*	*	*
9	*	*	*	*	*	*	*
10	*	*	*	*	*	*	*
11	*	*	*	*	*	*	*
12	*	*	*	*	*	*	*
13	*	*	*	*	*	*	*
14	*	*	*	*	*	*	*
15	*	*	*	*	*	*	*
16	*	*	*	*	*	*	*
17	*	*	*	*	*	*	*
18	*	*	*	*	*	*	*
19	*	*	*	*	*	*	*
20	*	*	*	*	*	*	*
21	*	*	*	*	*	*	*
22	*	*	*	*	*	*	*
23							

Channel 1

Total File Days Used 9
Total Transactions for 123 (5/3/82) to 148 (5/28/82)
(Each '*' represents 20 transactions.)

```

Hour |
0 |
1 |
2 |
3 |
4 |
5 |
6 |
7 | *****
8 | *****
9 | *****
10 | *****
11 | *****
12 | *****
13 | *****
14 | *****
15 | *****
16 | *****
17 | ***
18 |
19 |
20 | ****
21 | *
22 | *
23 |
+-----+-----+-----+-----+-----+-----+-----+-----+-----+
0.7   1.4   2.1   2.8   3.5   4.2   4.9
Channel 1
Total File Days Used 9
Average Percent of System Occupancy for 123 (5/3/82) to 148 (5/28/82)
(Each 'x' represents 0.07 percent.)

```

```

Hour |
0 |
1 |
2 |
3 |
4 |
5 |
6 | *****
7 | *****
8 | *****
9 | *****
10 | *****
11 | *****
12 | *****
13 | *****
14 | *****
15 | *****
16 | *****
17 | *****
18 | *****
19 | *****
20 | *****
21 | *****
22 | *****
23 |
+-----+-----+-----+-----+-----+-----+-----+-----+-----+
300.0 600.0 900.0 1200 1500 1800 2100
Channel 1
Total File Days Used 9
Average Seconds/Transaction for 123 (5/3/82) to 148 (5/28/82)
(Each 'x' represents 30 seconds.)

```

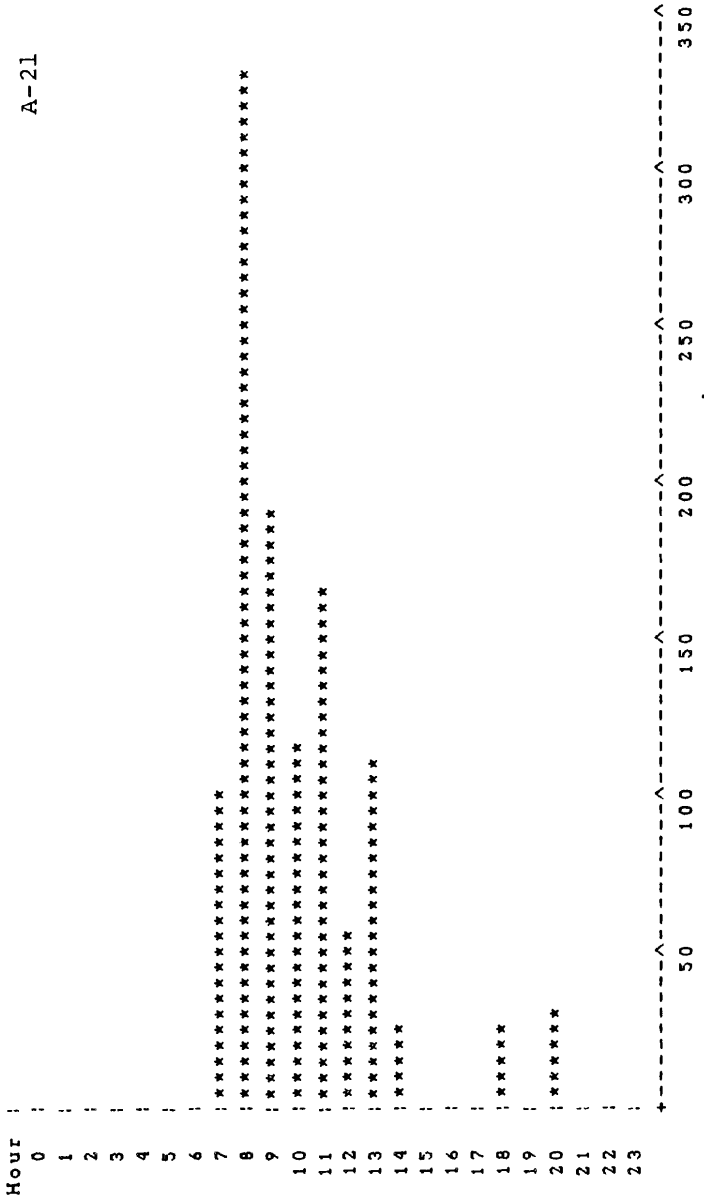

```

Hour :
0 :
1 :
2 :
3 :
4 :
5 :
6 :
7 : *****
8 : *****
9 : *****
10 : *****
11 : *****
12 : *****
13 : *****
14 : *****
15 :
16 :
17 :
18 : *****
19 :
20 : *****
21 :
22 :
23 :
-----^-----^-----^-----^-----^-----^-----^-----^-----^-----^
0.2 0.3 0.5 0.6 0.8 0.9 1.1
Channel 3
Total File Days Used 9
Average Percent of System Occupancy for 123 (5/3/82) to 148 (5/28/82)
(Each 'x' represents 0.015 percent.)

```

```

Hour :
0 :
1 :
2 :
3 :
4 :
5 :
6 :
7 : *****
8 : *****
9 : *****
10 : *****
11 : *****
12 : *****
13 : *****
14 : *****
15 :
16 :
17 : *****
18 : *****
19 :
20 : *****
21 : *****
22 : *****
23 :
-----^-----^-----^-----^-----^-----^-----^-----^-----^-----^
500.0 % 1000 % 1500 % 2000 % 2500 % 3000 % 3500
Channel 3
Total File Days Used 9
Average Seconds/Transaction for 123 (5/3/82) to 148 (5/28/82)
(Each 'x' represents 50 seconds.)

```

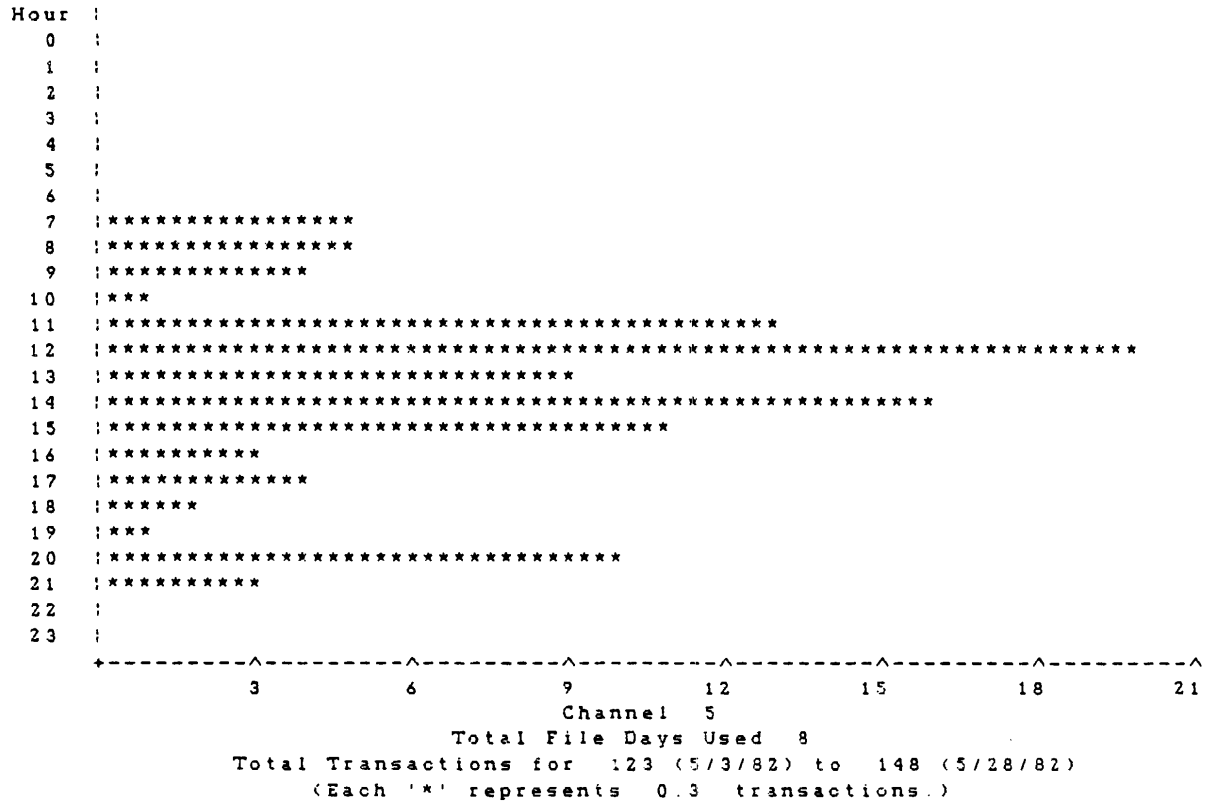
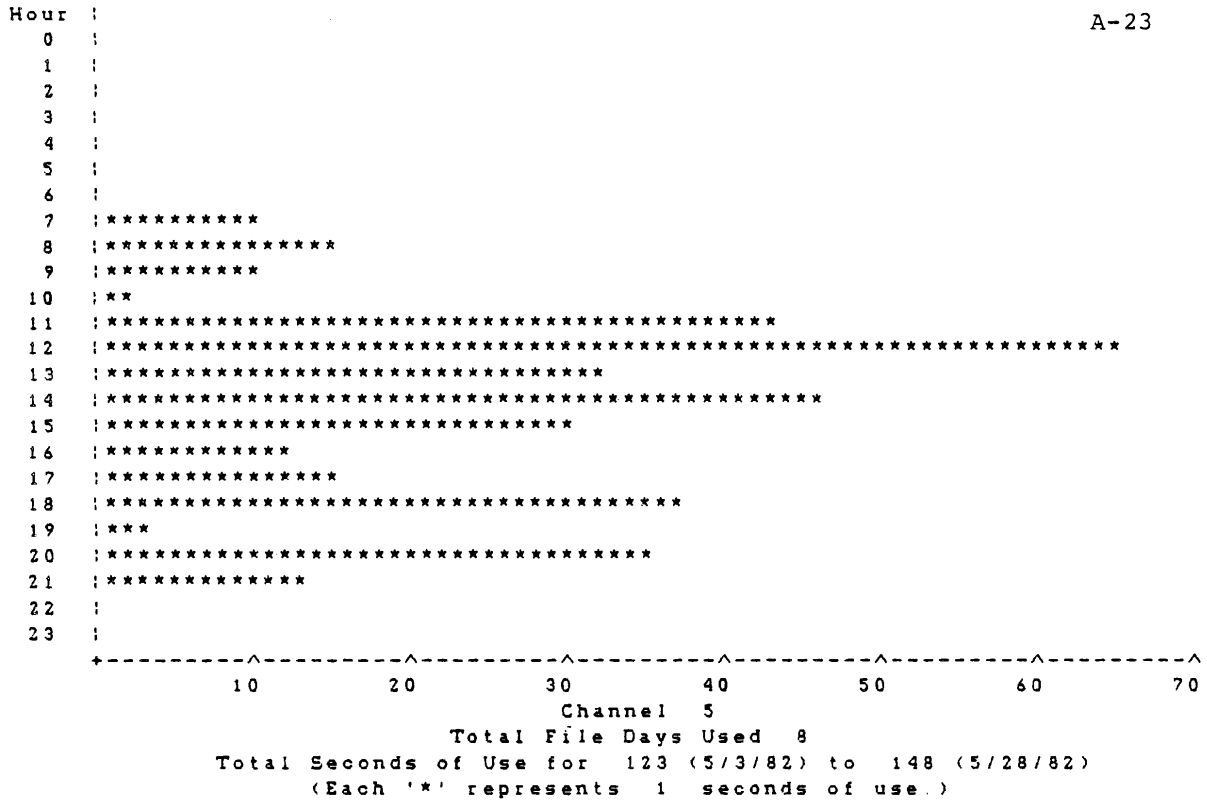

Hour	450	900	1350	1800	2250	2700	3150
0	*****	*****	*****	*****	*****	*****	*****
1	*****	*****	*****	*****	*****	*****	*****
2	*****	*****	*****	*****	*****	*****	*****
3	*****	*****	*****	*****	*****	*****	*****
4	*****	*****	*****	*****	*****	*****	*****
5	*****	*****	*****	*****	*****	*****	*****
6	*****	*****	*****	*****	*****	*****	*****
7	*****	*****	*****	*****	*****	*****	*****
8	*****	*****	*****	*****	*****	*****	*****
9	*****	*****	*****	*****	*****	*****	*****
10	*****	*****	*****	*****	*****	*****	*****
11	*****	*****	*****	*****	*****	*****	*****
12	*****	*****	*****	*****	*****	*****	*****
13	*****	*****	*****	*****	*****	*****	*****
14	*****	*****	*****	*****	*****	*****	*****
15	*****	*****	*****	*****	*****	*****	*****
16	*****	*****	*****	*****	*****	*****	*****
17	*****	*****	*****	*****	*****	*****	*****
18	*****	*****	*****	*****	*****	*****	*****
19	*****	*****	*****	*****	*****	*****	*****
20	*****	*****	*****	*****	*****	*****	*****
21	*****	*****	*****	*****	*****	*****	*****
22	*****	*****	*****	*****	*****	*****	*****
23	***	***	***	***	***	***	***

Channel 1
Total File Days Used 20
Total Seconds of Use for 152 (6/1/82) to 180 (6/29/82)
(Each '*' represents 45 seconds of use.)

Hour	200	400	600	800	1000	1200	1400
0	*****	*****	*****	*****	*****	*****	*****
1	*****	*****	*****	*****	*****	*****	*****
2	*****	*****	*****	*****	*****	*****	*****
3	*****	*****	*****	*****	*****	*****	*****
4	*****	*****	*****	*****	*****	*****	*****
5	*****	*****	*****	*****	*****	*****	*****
6	*****	*****	*****	*****	*****	*****	*****
7	*****	*****	*****	*****	*****	*****	*****
8	*****	*****	*****	*****	*****	*****	*****
9	*****	*****	*****	*****	*****	*****	*****
10	*****	*****	*****	*****	*****	*****	*****
11	*****	*****	*****	*****	*****	*****	*****
12	*****	*****	*****	*****	*****	*****	*****
13	*****	*****	*****	*****	*****	*****	*****
14	*****	*****	*****	*****	*****	*****	*****
15	*****	*****	*****	*****	*****	*****	*****
16	*****	*****	*****	*****	*****	*****	*****
17	*****	*****	*****	*****	*****	*****	*****
18	*****	*****	*****	*****	*****	*****	*****
19	*****	*****	*****	*****	*****	*****	*****
20	*****	*****	*****	*****	*****	*****	*****
21	*****	*****	*****	*****	*****	*****	*****
22	*****	*****	*****	*****	*****	*****	*****
23	**	**	**	**	**	**	**

Channel 1
Total File Days Used 20
Total Transactions for 152 (6/1/82) to 180 (6/29/82)
(Each '*' represents 20 transactions.)

Hour	0.7	1.4	2.1	2.8	3.5	4.2	4.9
0	*****	*****	*****	*****	*****	*****	*****
1	*****	*****	*****	*****	*****	*****	*****
2	*****	*****	*****	*****	*****	*****	*****
3	*****	*****	*****	*****	*****	*****	*****
4	*****	*****	*****	*****	*****	*****	*****
5	*****	*****	*****	*****	*****	*****	*****
6	*****	*****	*****	*****	*****	*****	*****
7	*****	*****	*****	*****	*****	*****	*****
8	*****	*****	*****	*****	*****	*****	*****
9	*****	*****	*****	*****	*****	*****	*****
10	*****	*****	*****	*****	*****	*****	*****
11	*****	*****	*****	*****	*****	*****	*****
12	*****	*****	*****	*****	*****	*****	*****
13	*****	*****	*****	*****	*****	*****	*****
14	*****	*****	*****	*****	*****	*****	*****
15	*****	*****	*****	*****	*****	*****	*****
16	*****	*****	*****	*****	*****	*****	*****
17	*****	*****	*****	*****	*****	*****	*****
18	*****	*****	*****	*****	*****	*****	*****
19	*****	*****	*****	*****	*****	*****	*****
20	*****	*****	*****	*****	*****	*****	*****
21	*****	*****	*****	*****	*****	*****	*****
22	*****	*****	*****	*****	*****	*****	*****
23	*****	*****	*****	*****	*****	*****	*****

Channel 1
 Total File Days Used 20
 Average Percent of System Occupancy for 152 (6/1/82) to 180 (6/29/82)
 (Each 'x' represents 0.07 percent.)

Hour	80.0	160.0	240.0	320.0	400.0	480.0	560.0
0	*****	*****	*****	*****	*****	*****	*****
1	*****	*****	*****	*****	*****	*****	*****
2	*****	*****	*****	*****	*****	*****	*****
3	*****	*****	*****	*****	*****	*****	*****
4	*****	*****	*****	*****	*****	*****	*****
5	*****	*****	*****	*****	*****	*****	*****
6	*****	*****	*****	*****	*****	*****	*****
7	*****	*****	*****	*****	*****	*****	*****
8	*****	*****	*****	*****	*****	*****	*****
9	*****	*****	*****	*****	*****	*****	*****
10	*****	*****	*****	*****	*****	*****	*****
11	*****	*****	*****	*****	*****	*****	*****
12	*****	*****	*****	*****	*****	*****	*****
13	*****	*****	*****	*****	*****	*****	*****
14	*****	*****	*****	*****	*****	*****	*****
15	*****	*****	*****	*****	*****	*****	*****
16	*****	*****	*****	*****	*****	*****	*****
17	*****	*****	*****	*****	*****	*****	*****
18	*****	*****	*****	*****	*****	*****	*****
19	*****	*****	*****	*****	*****	*****	*****
20	*****	*****	*****	*****	*****	*****	*****
21	*****	*****	*****	*****	*****	*****	*****
22	*****	*****	*****	*****	*****	*****	*****
23	*****	*****	*****	*****	*****	*****	*****

Channel 1
 Total File Days Used 20
 Average Seconds/Transaction for 152 (6/1/82) to 180 (6/29/82)
 (Each 'x' represents 8 seconds.)

```

Hour :
0 :
1 :
2 :
3 :
4 :
5 :
6 :
7 :
8 : *****
9 : *****
10 : *****
11 : *****
12 : *****
13 : *****
14 : *****
15 : ****
16 :
17 : *****
18 : *****
19 : ***
20 :
21 : *****
22 :
23 :

```

```

+-----^-----^-----^-----^-----^-----^-----^-----^-----^-----^
          0.2      0.3      0.5      0.6      0.8      0.9      1.1
                        Channel 3
                Total File Days Used 20
Average Percent of System Occupancy for 152 (6/1/82) to 180 (6/29/82)
(Each '*' represents 0.015 percent.)

```

```

Hour :
0 : *****
1 : *
2 :
3 :
4 :
5 :
6 :
7 : *****
8 : *****
9 : *****
10 : *****
11 : *****
12 : *****
13 : *****
14 : *****
15 : *****
16 : ****
17 : *****
18 : *****
19 : *****
20 : *****
21 : *****
22 : *****
23 : *****

```

```

+-----^-----^-----^-----^-----^-----^-----^-----^-----^-----^
          300.0    600.0    900.0    % 1200    % 1500    % 1800    % 2100
                        Channel 3
                Total File Days Used 20
Average Seconds/Transaction for 152 (6/1/82) to 180 (6/29/82)
(Each '*' represents 30 seconds.)

```



```

Hour :
0 :
1 :
2 :
3 :
4 :
5 :
6 :
7 : *****
8 : *****
9 : *****
10 : *****
11 : *****
12 : *****
13 : *****
14 : *****
15 : *****
16 : *****
17 : *****
18 :
19 : *****
20 :
21 : *
22 : *
23 : *****
+-----^-----^-----^-----^-----^-----^-----^-----^-----^
0.1 0.2 0.3 0.4 0.5 0.5 0.5 0.5 0.6
Channel 5
Total File Days Used 19
Average Percent of System Occupancy for 152 (6/1/82) to 180 (6/29/82)
(Each '*' represents 9E-03 percent.)

```

```

Hour :
0 : *****
1 :
2 :
3 :
4 :
5 :
6 :
7 : *****
8 : *****
9 : *****
10 : *****
11 : *****
12 : *****
13 : *****
14 : *****
15 : *****
16 : *****
17 : *****
18 : *****
19 : *****
20 :
21 : *****
22 : *****
23 : *****
+-----^-----^-----^-----^-----^-----^-----^-----^-----^
250.0 500.0 750.0 % 1000 % 1250 % 1500 % 1750
Channel 5
Total File Days Used 19
Average Seconds/Transaction for 152 (6/1/82) to 180 (6/29/82)
(Each '*' represents 25 seconds.)

```

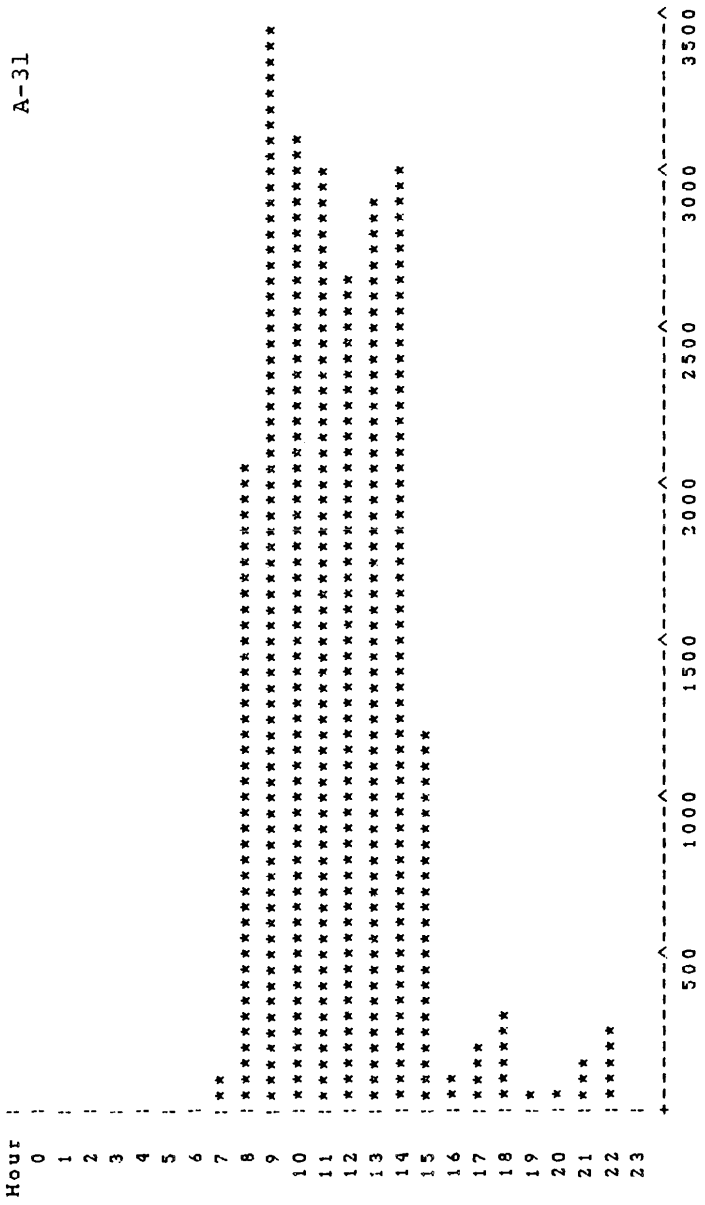

Channel 1
 Total File Days Used 21
 Total Seconds of Use for 182 (7/1/82) to 211 (7/30/82)
 (Each '*' represents 50 seconds of use.)

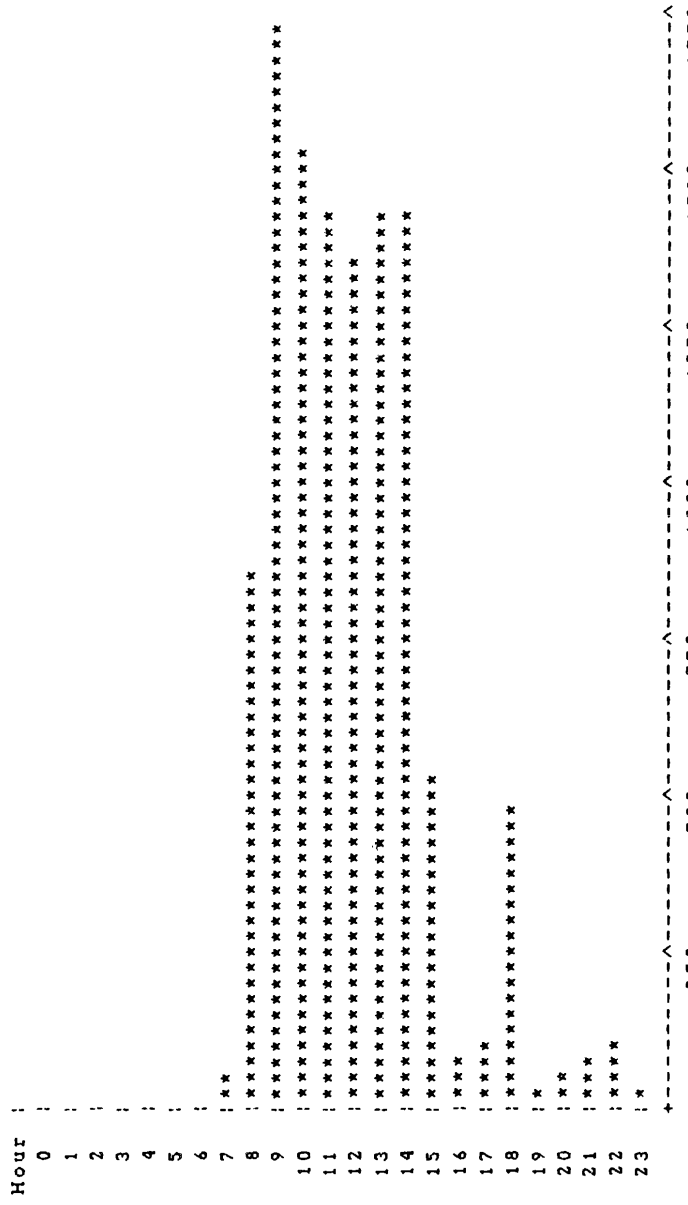

Channel 1
 Total File Days Used 21
 Total Transactions for 182 (7/1/82) to 211 (7/30/82)
 (Each '*' represents 25 transactions.)

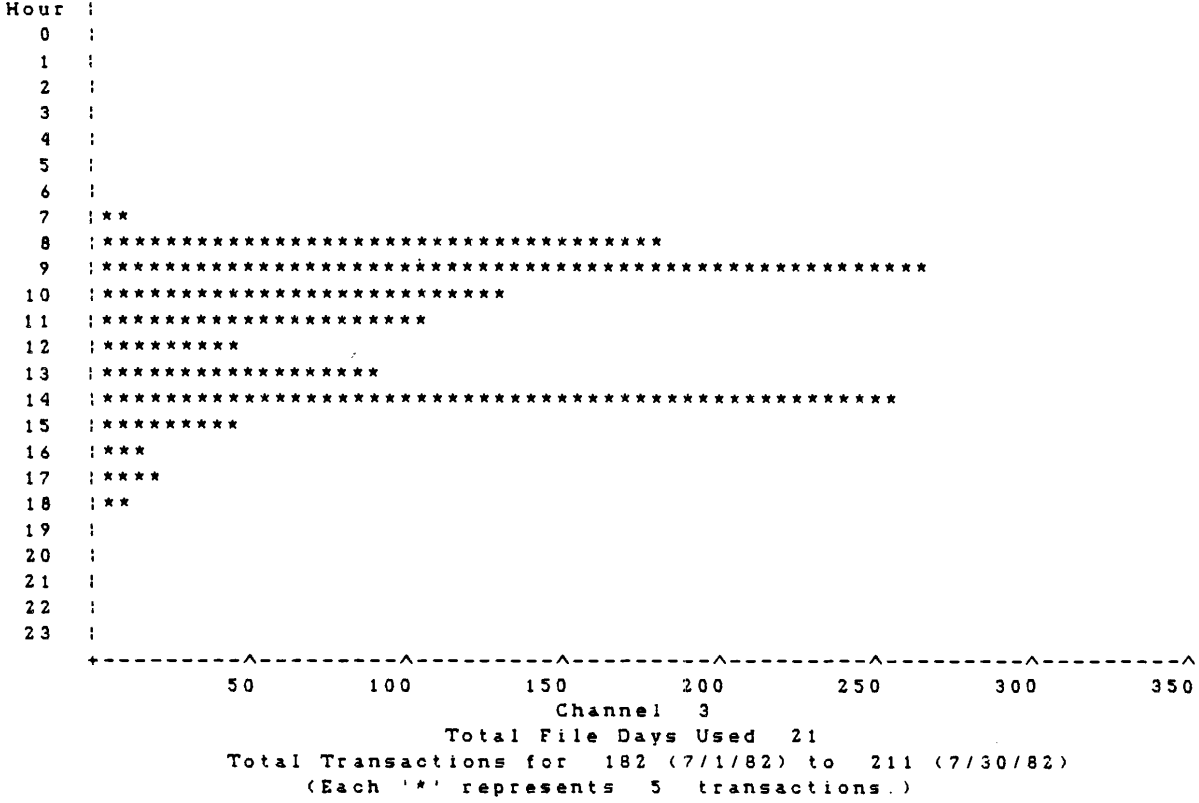
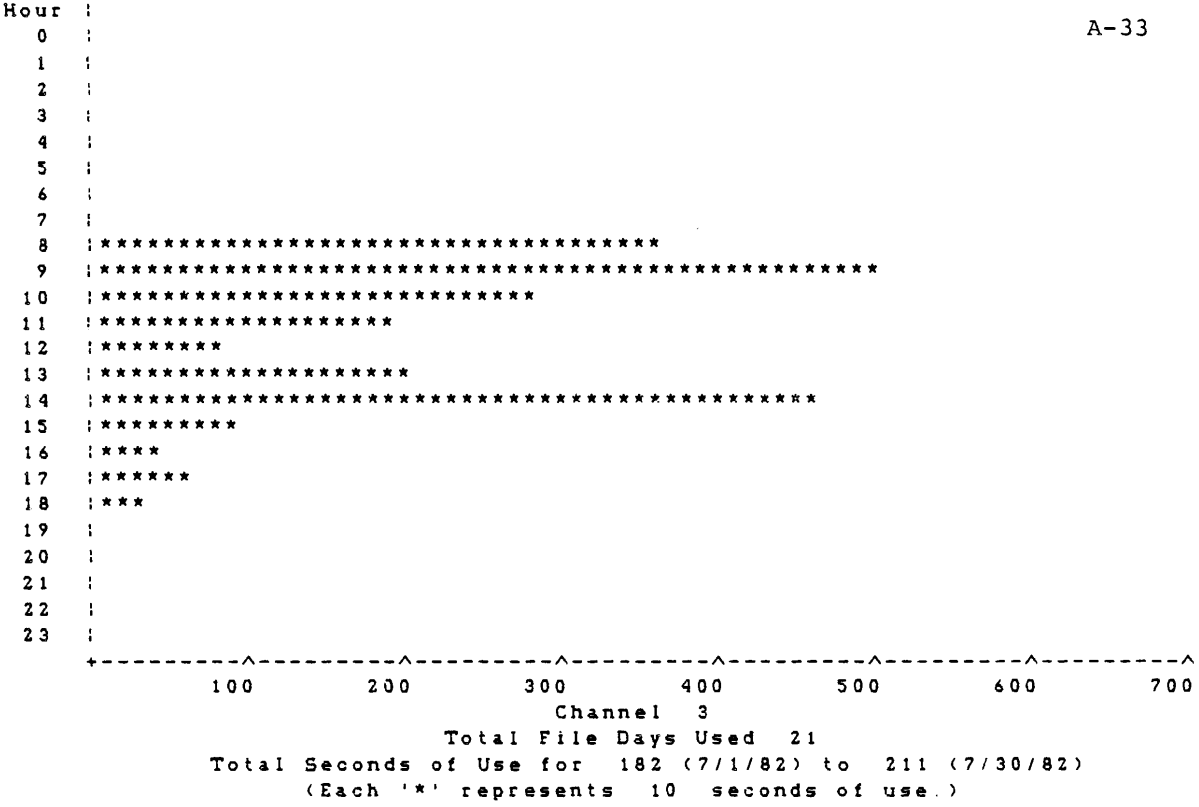

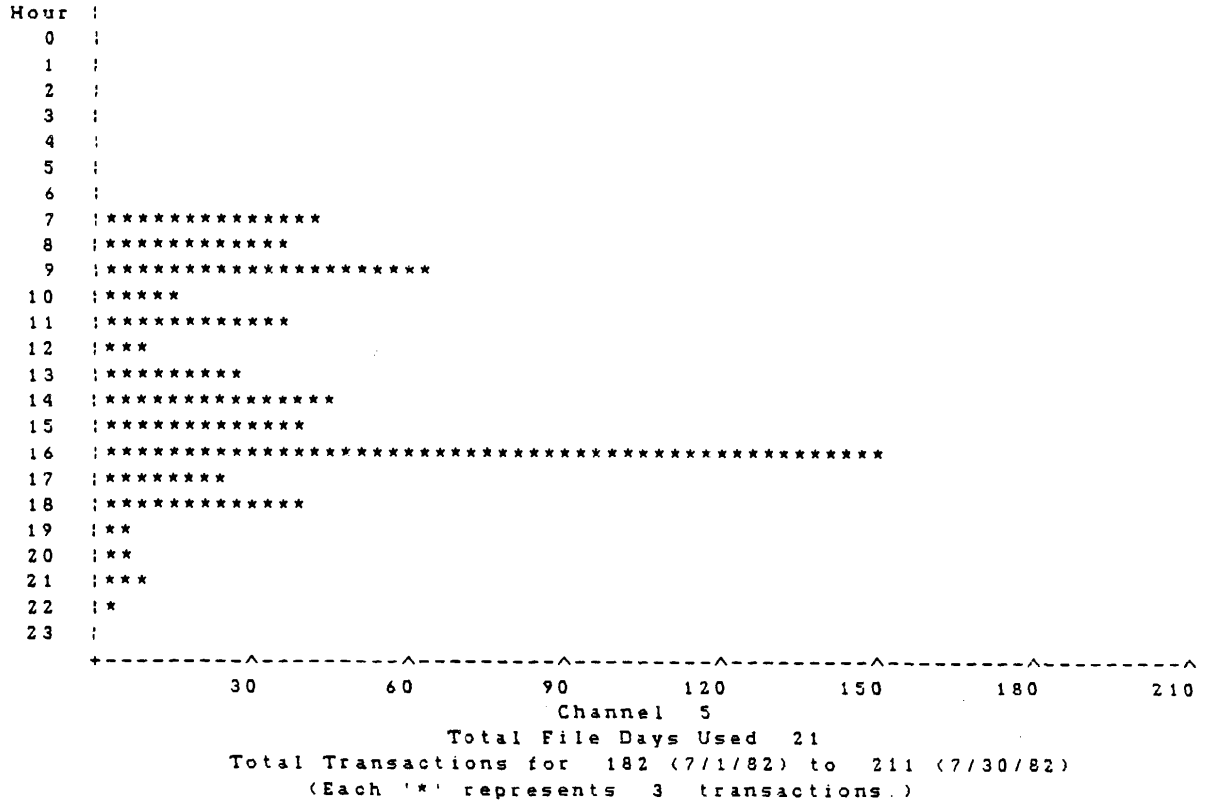
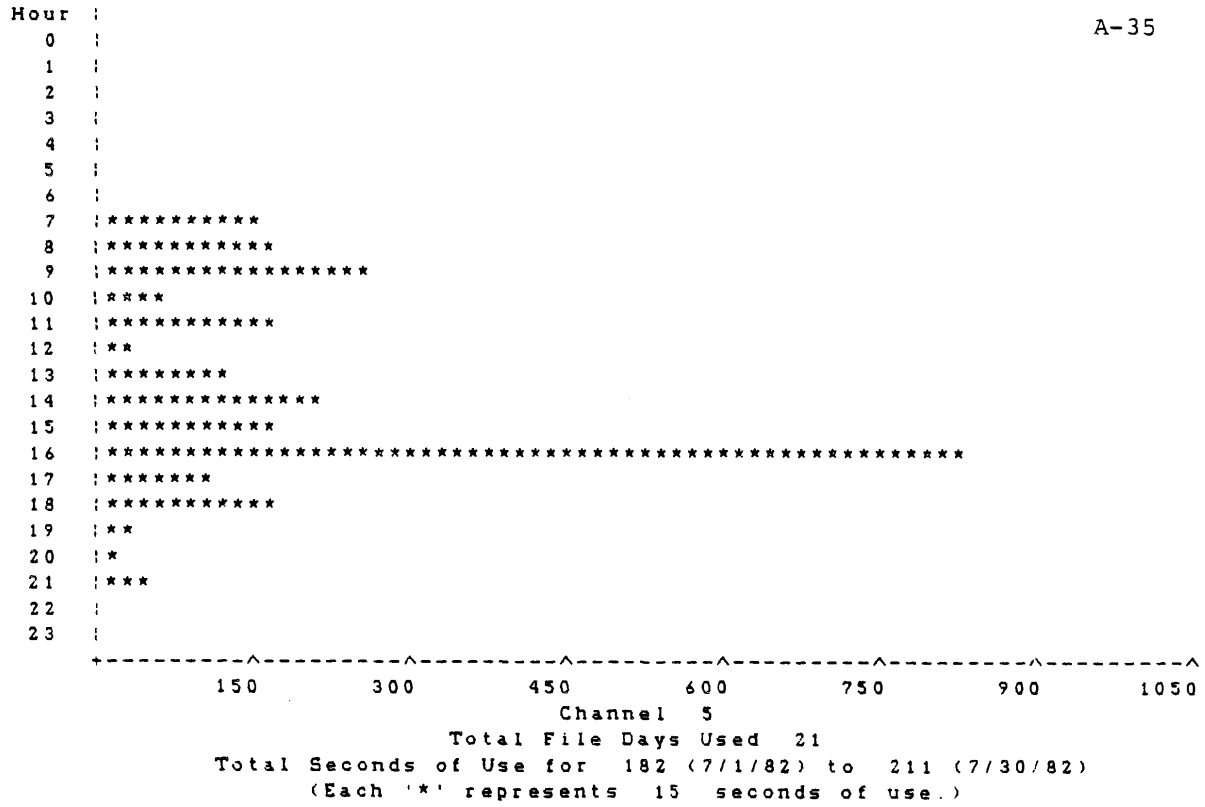

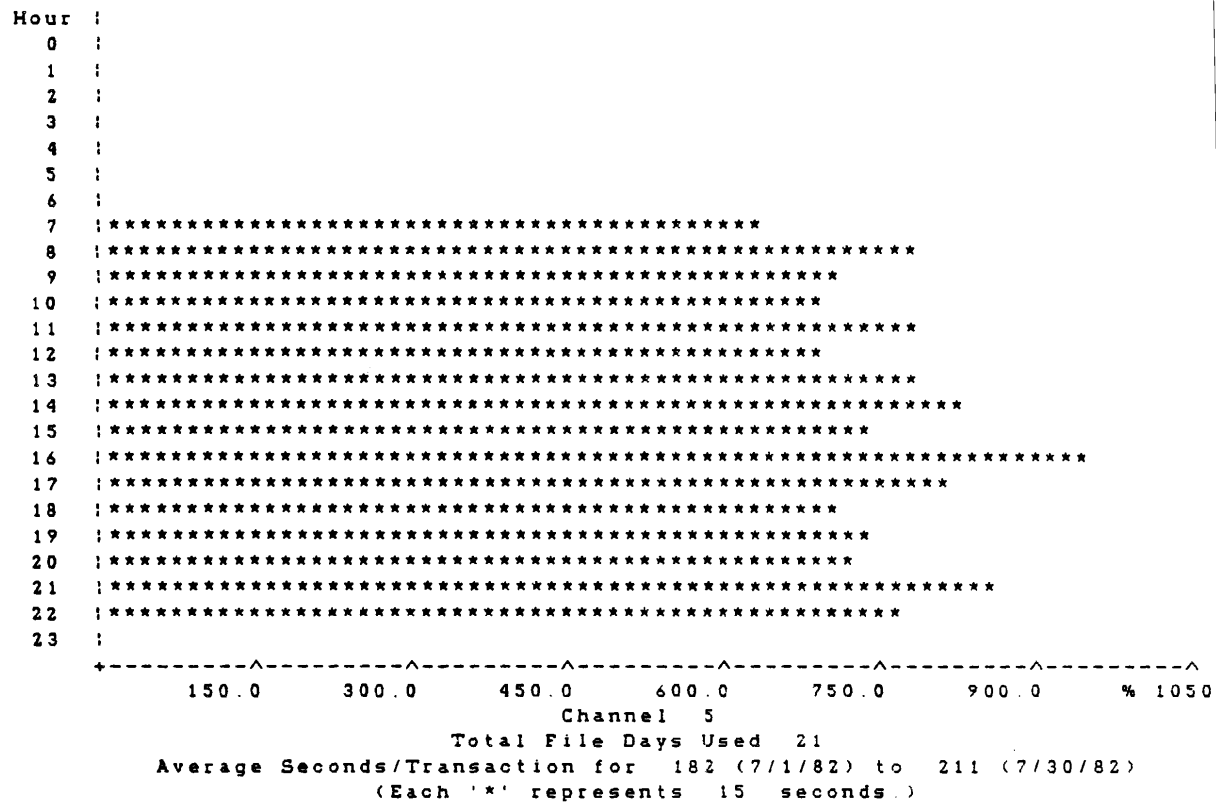
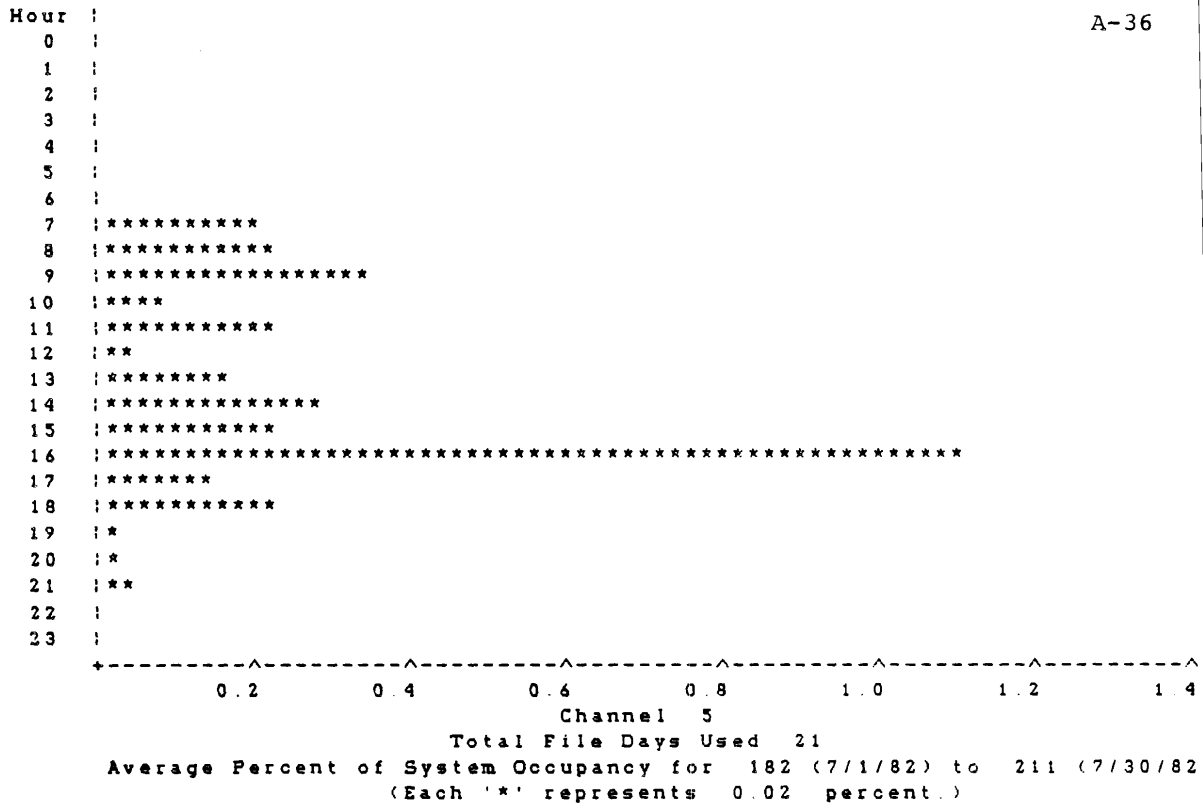

Hour	550	1100	1650	2200	2750	3300	3850
0							
1							
2							
3							
4	*****						
5							
6							
7	*****						
8	*****						
9	*****						
10	*****						
11	*****						
12	*****						
13	*****						
14	*****						
15	*****						
16	*****						
17	*****						
18	*****						
19	*****						
20	**						
21	*						
22							
23							

Channel-1
 Total File Days Used 20
 Total Seconds of Use for 214 (8/2/82) to 239 (8/27/82)
 (Each '*' represents 55 seconds of use.)

Hour	250	500	750	1000	1250	1500	1750
0							
1							
2							
3							
4	*						
5							
6							
7	*****						
8	*****						
9	*****						
10	*****						
11	*****						
12	*****						
13	*****						
14	*****						
15	*****						
16	*****						
17	*****						
18	*****						
19	**						
20	**						
21	**						
22							
23							

Channel-1
 Total File Days Used 20
 Total Transactions for 214 (8/2/82) to 239 (8/27/82)
 (Each '*' represents 25 transactions.)

```

Hour |
  0 |
  1 |
  2 |
  3 |
  4 | *****
  5 |
  6 |
  7 | *****
  8 | *****
  9 | *****
 10 | *****
 11 | *****
 12 | *****
 13 | *****
 14 | *****
 15 | *****
 16 | *****
 17 | *****
 18 | *****
 19 | *****
 20 | **
 21 | *
 22 |
 23 |
+-----+-----+-----+-----+-----+-----+-----+-----+-----+
0.7   1.4   2.1   2.8   3.5   4.2   4.9
      Channel 1
Total File Days Used 20
Average Percent of System Occupancy for 214 (8/2/82) to 239 (8/27/82)
(Each '*' represents 0.07 percent.)

```

```

Hour |
  0 | **
  1 |
  2 |
  3 | *****
  4 | *****
  5 | *****
  6 |
  7 | *****
  8 | *****
  9 | *****
 10 | *****
 11 | *****
 12 | *****
 13 | *****
 14 | *****
 15 | *****
 16 | *****
 17 | *****
 18 | *****
 19 | *****
 20 | *****
 21 | *****
 22 | *****
 23 | *****
+-----+-----+-----+-----+-----+-----+-----+-----+-----+
550.0  % 1100  % 1650  % 2200  % 2750  % 3300  % 3850
      Channel 1
Total File Days Used 20
Average Seconds/Transaction for 214 (8/2/82) to 239 (8/27/82)
(Each '*' represents 55 seconds.)

```

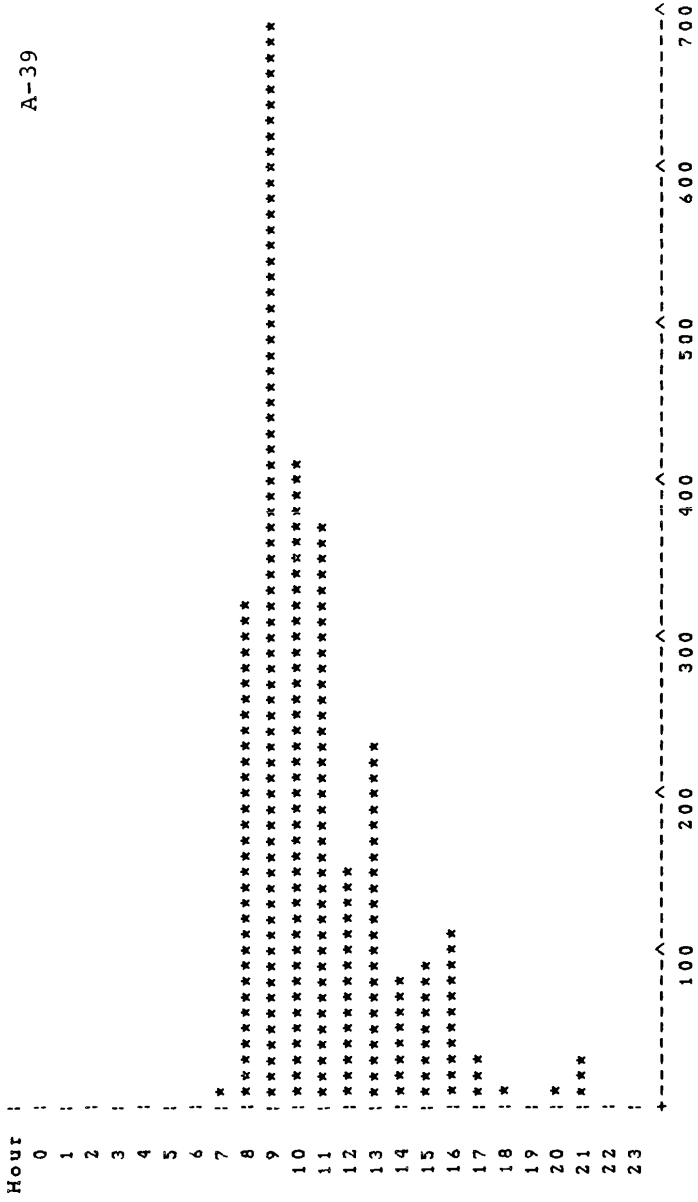

Hour	0.2	0.3	0.5	0.6	0.8	0.9	1.1
0							
1							
2							
3							
4							
5							
6							
7	*						
8	*	*	*	*	*	*	*
9	*	*	*	*	*	*	*
10	*	*	*	*	*	*	*
11	*	*	*	*	*	*	*
12	*	*	*	*	*	*	*
13	*	*	*	*	*	*	*
14	*	*	*	*	*	*	*
15	*	*	*	*	*	*	*
16	*	*	*	*	*	*	*
17	***						
18	*						
19							
20	*						
21	***						
22							
23							

Channel 3
 Total File Days Used 20
 Average Percent of System Occupancy for 214 (8/2/82) to 239 (8/27/82)
 (Each '*' represents 0.015 percent.)

Hour	80.0	160.0	240.0	320.0	400.0	480.0	560.0
0							
1							
2							
3							
4							
5	*						
6							
7	*	*	*	*	*	*	*
8	*	*	*	*	*	*	*
9	*	*	*	*	*	*	*
10	*	*	*	*	*	*	*
11	*	*	*	*	*	*	*
12	*	*	*	*	*	*	*
13	*	*	*	*	*	*	*
14	*	*	*	*	*	*	*
15	*	*	*	*	*	*	*
16	*	*	*	*	*	*	*
17	*	*	*	*	*	*	*
18	*	*	*	*	*	*	*
19	*	*	*	*	*	*	*
20	*	*	*	*	*	*	*
21	*	*	*	*	*	*	*
22	*	*	*	*	*	*	*
23	****						

Channel 3
 Total File Days Used 20
 Average Seconds/Transaction for 214 (8/2/82) to 239 (8/27/82)
 (Each '*' represents 8 seconds.)

