

# Distinguishing Motor Starts From Short Circuits Through Phase-Angle Measurements

Michael R. Yenckek, James C. Cawley, Albert L. Brautigam, and Jeffrey Shawn Peterson

**Abstract**—The National Institute for Occupational Safety and Health investigated how the starting of induction motors may cause nuisance tripping of short-circuit protection on coal mine power systems. This research had a dual purpose: 1) to identify how motor-start waveforms differ from those for short circuits and 2) to devise a method to provide short-circuit protection without intentional time delays to account for motor starts. This technology will help ensure that surface temperatures of energized electrical apparatus will not exceed gas or dust ignition thresholds when short circuits occur.

**Index Terms**—Longwalls, mining, motor, phase angle, short circuit.

## I. INTRODUCTION

**P**ROPOSED rules for high-voltage electrical equipment used in longwall face areas of underground coal mines were published on August 27, 1992 by the Mine Safety and Health Administration (MSHA) [6]. The intent of these regulations is to reduce the likelihood of fire, explosion, and shock hazards by citing requirements for electrical enclosures, circuit protection, testing, and personnel protection. The operational limits for short-circuit protective devices are proposed within section 75.814 of these rules.

Short-circuit protection for electrical apparatus in underground coal mines is critical. When different phases of an electrical circuit inadvertently come in contact, thousands of amperes may flow. Currents of this magnitude can cause explosions and fires if permitted to exist even for periods as brief as 1 s. The thermal energy expended is directly related to  $I^2t$  (the square of the current times the time) [2]. Consequently, protective device settings must be specified with a maximum sensitivity to current ( $I$ ) and a minimum reaction time ( $t$ ).

Unfortunately, extremely low current settings may interfere with mining operations by reacting to normal transient events, such as the starting of motors. In response, the proposed MSHA rules specify maximum intentional time delays for short-circuit

protection of cables extending from the power center to motor starters. In the future, the trend toward higher efficiency motors with greater peak starting currents may necessitate even longer delays. However, in background discussion of the rules, MSHA solicits comments regarding the elimination of intentional time delays with a conjunctive increase in current settings. This reflects the dilemma of short-circuit protection, namely, that circuit protective devices should have high sensitivity to faults, but not interfere with normal mining operations. Accordingly, MSHA requested a high-priority research effort aimed at eliminating intentional time delays in short-circuit protection.

The Pittsburgh Research Laboratory of the National Institute for Occupational Safety and Health (NIOSH) investigated how the starting of induction motors may cause nuisance tripping of short-circuit protection on coal mine power systems.<sup>1</sup> The specific objectives of this research project were to: 1) identify how motor-start waveforms differ from those for short circuits and 2) devise a method to provide short-circuit protection without intentional time delays to account for motor starts. Minimal reaction times to short circuits will help ensure that the temperatures of energized electrical apparatus will not exceed gas or dust ignition thresholds when such faults occur. Additionally, the capability of distinguishing between motor-start and short-circuit events precludes nuisance protective device activation. Although the project focused on high-voltage longwalls, the technology subsequently developed may be applicable to low- and medium-voltage mine power systems as well.

## II. BACKGROUND

Protection against short circuits on high-voltage mine power circuits is typically provided by vacuum interrupters. The current magnitude thresholds or settings at which these devices operate are specified through the MSHA approval process [3] for high-voltage longwalls. The initial inrush currents, demanded by large induction motors starting across the line, may exceed these settings and activate the protection devices needlessly. Consequently, to prevent nuisance tripping of the short-circuit protection, it is desirable to seek a means to momentarily disable or inhibit the protection device activation for a finite period following motor energization.

A speed-sensing switch could logically be utilized to signal motor start, but requires direct access to rotating parts, which is sometimes not feasible or economical. In addition, this sensor

M. R. Yenckek, J. C. Cawley, and A. L. Brautigam are with the Mining Injury Prevention Branch, Pittsburgh Research Laboratory, National Institute for Occupational Safety and Health, Pittsburgh, PA 15236-0070 USA (e-mail: mby5@cdc.gov; gzc4@cdc.gov; aib4@cdc.gov).

J. S. Peterson is with the Hearing Loss Prevention Branch, Pittsburgh Research Laboratory, National Institute for Occupational Safety and Health, Pittsburgh, PA 15236-0070 USA (e-mail: jnp3@cdc.gov).

<sup>1</sup>This research originated under the U.S. Bureau of Mines prior to its transfer to the Office for Mine Safety and Health Research, Pittsburgh Research Laboratory, National Institute for Occupational Safety and Health, in 1996.



Fig. 1. Measuring motor-start waveforms on a 950-V continuous mining machine.

may be slow to operate where load inertia is high. This is also true for induction-disk impedance or distance relays used primarily for fault protection on transmission lines [8], [10], [5]. In the late 1970s, a system was developed in the U.K. that monitored the phase angle between voltage and current to distinguish between faults and motor starts [7]. Despite promising results, this technology has not been incorporated in short-circuit protection for U.S. mines. Given the catastrophic potential of inadequate electrical protection, it is imperative to reexamine this problem to minimize any intentional time delays while maximizing current sensitivity.

### III. MOTOR-START EVALUATIONS

Electrical safety can be enhanced if the circuit-protection device recognizes and reacts only to short circuits. To devise a means to discriminate between motor starts and short circuits, one must first investigate how the waveforms of each event differ. Any distinguishing characteristics may then be keyed upon through the design of sensing circuitry. Accordingly, it was decided to record the voltage and current waveforms of mine induction motors of various voltages and evaluate their salient characteristics.

#### A. Field Tests of Mine Motors

To gain insight into motor-start signatures, field tests of a variety of mine motors were conducted. These included motors with application in both longwall and continuous mining, with voltages ranging from 440 to 4160 V and power ratings from 10 to 450 hp. Because mine motors are typically started across the line with full voltage, it was necessary to select test sites with this capability. These included a rebuild shop with 440- and 550-V motors up to 150 hp. At another facility, a 4160-V conveyor motor was evaluated. Finally, the pump, conveyor, and cutter motors of a 950-V continuous miner were analyzed (Fig. 1). To ensure random motor energization relative to the voltage cycle, 12 successive start recordings were made of each motor. Recordings were usually made at the terminals of the motor. However, recordings of the continuous miner motors

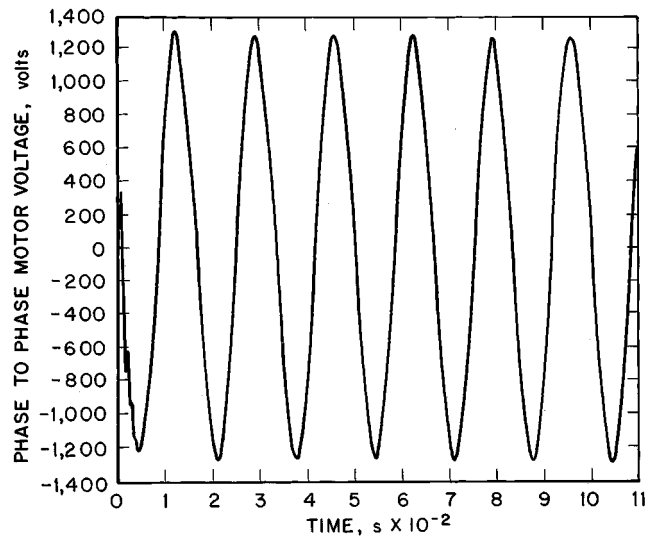

Fig. 2. Phase-to-phase voltage waveform for start of 950-V 165-hp motor.

were made at both the motor terminals and in the load center that fed the 153-m trailing cable.

#### B. Data Acquisition Hardware and Software

Transducers were used to record three-phase currents during motor starts. The Hall-effect current sensors featured a frequency response from dc to 1000 Hz to capture higher frequency transients that may be present. The 1000-A split-core configurations had 5000-V line-to-output isolation. They were used in conjunction with matched signal conditioners having  $\pm 10$ -V outputs directly proportional to the amplitude of the input signal. Tests with low-voltage motors utilized 0 to  $\pm 1000$ -V voltage transducers with a proportional 0 to  $\pm 10$ -V output. These sensors had a frequency range of dc to 5000 Hz. At 1000 V and above, custom potential transformers were used to acquire the voltage waveform. The current signal conditioners and voltage sensors were connected to ground-isolation boards, 1000-Hz programmable filters, and a 12-bit analog-to-digital board. This board had the capability of scanning up to eight separate channels and was equipped with simultaneous sample-and-hold circuitry that eliminated phase shifts among channels. The output of this board was digitally recorded in a multichannel file using a 486-based laptop personal computer that was made rugged for field use. A custom computer program was written that allowed the user to choose the number of channels to record at sampling rates up to 30 720 Hz per channel. During acquisition, data were written directly to disk with data files saved in binary format.

#### C. Motor Waveform Analyses

The motor-start voltage and current data were subsequently imported into a commercial data analysis package. Three-phase waveforms of voltage and current were plotted versus time for each of the motor tests. Typical plots are shown in Figs. 2 and 3. The inrush current following circuit energization has the potential to cause nuisance tripping of the short-circuit protection. It lasts for a time period that depends on the motor characteristics and loading. Closer examination of the time-varying signal revealed high-frequency oscillations within the first few

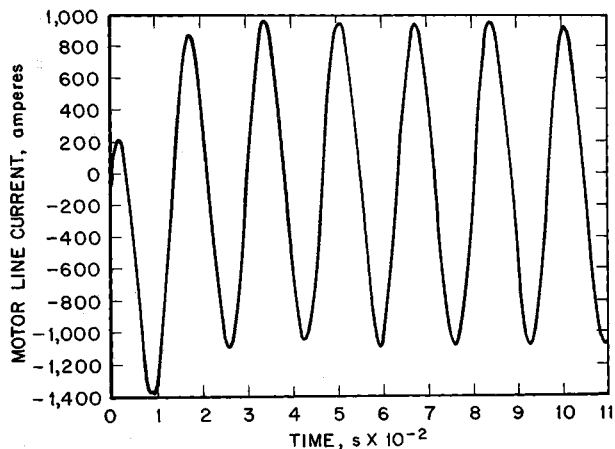

Fig. 3. Line-current waveform for start of 950-V 165-hp motor.

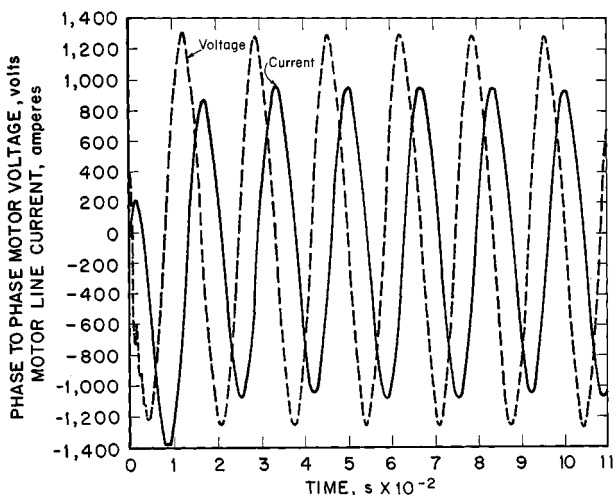

Fig. 4. Superposition of motor-start voltage and current waveforms.

milliseconds following energization. These perturbations were later attributed to contact bounce. A fast Fourier transform of the current waveforms displayed no frequencies other than the fundamental and its harmonics. Consequently, the examination of individual motor-start waveforms revealed no unusual characteristics upon which a motor-start detection scheme could be keyed.

Attention then turned to a study of the induction motor phase angle during starting. The phase angle may be obtained by superposing the voltage and current waveforms of a particular phase on a common time scale (Fig. 4) and recognizing that nominal  $30^\circ$  phase shifts were inherent with the phase-to-phase connections of the voltage transducers. It should be noted that the phase angles observed were not equivalent to those associated with power factor. The angle in degrees between two corresponding points of the waveforms may be derived by considering that, at a frequency of 60 Hz, one  $360^\circ$  waveform cycle is completed every 0.01667 s.

Typical inductive reactance-to-resistance ( $X/R$ ) ratios for induction motors, published in the IEEE "Red Book" [1], are in the range of 10 to 20. A fault on a circuit feeding an induction motor essentially shunts that inductive load, decreasing the phase angle between the voltage and current. Further, it is known that the phase angle of an induction motor during start is larger

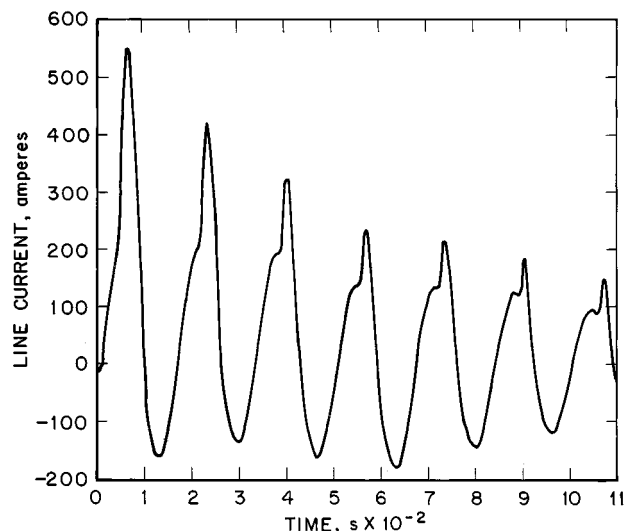

Fig. 5. Current waveform distortion of pump motor on continuous mining machine.

than that at full load [10]. Accordingly, the phase angle between the voltage and starting current must theoretically be larger on any given mine motor circuit than that resulting from a fault.

#### D. Motor-Start Phase-Angle Observations

Phase angles from start to full speed were derived from the motor waveforms recorded during field tests. The voltage and current waveforms were superposed and the time lag calculated at the zero crossings from energization to the point where the motor had attained full speed. Initial analyses involved nine unloaded, Class H, 440- and 550-V induction motors at a rebuild facility. The angle between voltage and current for the first and second zero crossings was found to vary by as much as  $50^\circ$ , not only among each of the three phases for a given test, but also for any given phase in successive tests. In addition, phase-angle variations were observed even after the motor attained full speed. A number of factors contributed to these phenomena. First, in many cases immediately following energization, the current waveforms exhibited a transient distortion that affected the exact time of the zero crossing. High-frequency oscillations due to contact bounce enhanced these irregularities. More importantly, the position of the voltage wave of a particular phase relative to the time of energization had an even greater impact on the phase angle. For example, if the voltage of a given phase was approaching a zero crossing and about to change polarity at the moment of motor energization, the resultant current wave for that phase would exhibit distortion during the first cycle (Figs. 2 and 3). Further, some of the inconsistencies may be attributed simply to the fact that all of the motors were tested on the shop floor without any mechanical load on their shafts. Repeatable phase angles were observed in subsequent tests of a loaded 4160-V 450-hp motor at another facility and motors under load on a continuous miner. Finally, as expected, there were differences observed in phase angles during starts with motors of different horsepower or manufacturers.

Next, the results of tests on continuous mining machine motors were analyzed. During data acquisition, considerable waveform distortion of the pump motor current was noted (Fig. 5).

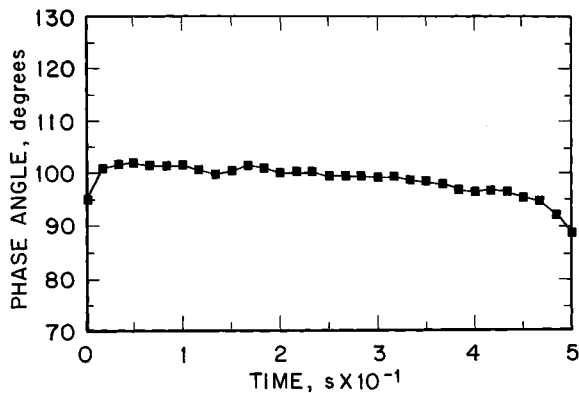

Fig. 6. Phase angle versus time during start of cutter.

Again, there was some variation among calculated phase angles during the first two cycles, but not to the degree observed with unloaded motors. Despite the waveform distortion, following the first two cycles and continuing to running speed, phase-angle magnitude behaved much more predictably over time among phases and successive tests. Fig. 6 shows that the phase angle from start to full speed for the cutter motor declined almost linearly as measured at the power center. Not surprisingly, because trailing cables exhibit a lower  $X/R$  ratio compared with that of motors, the phase angles calculated at the motor terminals during starts were on average  $5^\circ$  greater than those obtained from tests at the power center.

These analyses provided insight into the behavior of the phase angle between the current and voltage of a motor during start. They showed that, for a loaded motor after the first two cycles, the phase angle was relatively predictable. Consequently, the phase angle can be a reasonable basis for a methodology designed to distinguish between motor starts and short circuits on mine power systems.

#### IV. MOTOR-START DETECTION SCHEME

The proposed MSHA rules for high-voltage longwalls permit a maximum intentional time delay in short-circuit protection of 0.25 s or 15 cycles [6]. To minimize electrical fire hazards, a motor-start detection scheme should react much faster, ideally with no intentional time delay. Initially, it was believed that commercial phase-angle meters might be suited for incorporation into a detection system. However, the typical response times specified for these instruments was found to be 100 ms, which is too slow for consideration. Minimal time delay is best achieved through a digital-based design that does not rely on computational processes or integration of 60-Hz-power waveforms. Accordingly, the approach was to devise a means to detect the time between each zero crossing of the voltage and current signals beginning with the first half-cycle.

##### A. Prototype Circuit Operation

The prototype circuit is shown in Fig. 7. The circuit can monitor the current and voltage waveforms for one phase of a three-phase circuit. A suitable potential transformer, or equivalent

transducer is required for a line-to-line voltage measurement and a current transducer is required for the phase current measurement. After detection of a high-current condition, the digital logic performs the following operations:

- starts an initial delay;
- at the conclusion of the initial delay, measures the actual phase angle and compares it against a desired minimum set point;
- at the conclusion of the initial delay, initiates a motor locked (stalled) rotor timeout interval;
- controls the main circuit breaker interface relay.

To accurately measure the phase-angle electrical degrees during each half-cycle, a crystal-controlled oscillator was selected as the time reference. Oscillator pulses generated during zero crossings of voltage and current are counted and compared with a preset (phase-angle) delay. The inherent  $30^\circ$  shift between the line-to-line and phase voltage waveforms is accounted for by the detector circuitry. If the angle between voltage and current exceeds the setting of the circuit and current magnitude is high, the device sends a signal to inhibit circuit breaker action. An adjustable initial time delay was incorporated to account for switching transients which can distort phase angle measurements during the first few cycles. Situations where high current is detected and the phase angle is equal to or greater than the set-point minimum, could be indicative of a motor with a locked (stalled) rotor. This situation should be detected and cleared by tripping the main breaker after a finite timeout interval. A timeout interval of from zero to 255 voltage half-cycles is incorporated to accomplish this. Three prototypes (one per phase) were then constructed and tested in the laboratory.

##### B. Test Results

The detector circuit was tested using a 50-hp 460-V induction motor in the laboratory with an unloaded 95-kVA generator coupled to its shaft. The phase shift between motor voltage and startup current, was observed to be approximately  $90^\circ$ , implying a  $60^\circ$  phase angle considering the phase-to-phase voltage connections. The performance of the three-phase detector circuitry was evaluated by adjusting initial time delays, phase angle thresholds, and locked-rotor timeout. Three-phase motor voltages and currents were recorded along with detector outputs. A typical test result is shown in Fig. 8. The current detection threshold for the three-phase detection circuits was set at 300 A. In practice, this value would be fixed at the required short circuit setting of the circuit breaker. Since the 50-hp laboratory motor start currents exceeded this value, the detectors were activated. The intentional time delay for all three phase detectors was set at one cycle. In application, this value is adjustable up to four cycles to account for switching transients that may distort phase angle measurements. For test purposes, the phase angle detection thresholds for phases A, B, and C were set at  $50^\circ$ ,  $60^\circ$ , and  $70^\circ$ , respectively. In actuality, the thresholds would be set to the same value. Fig. 8 depicts voltage, current, and detector output signals for all three phases.

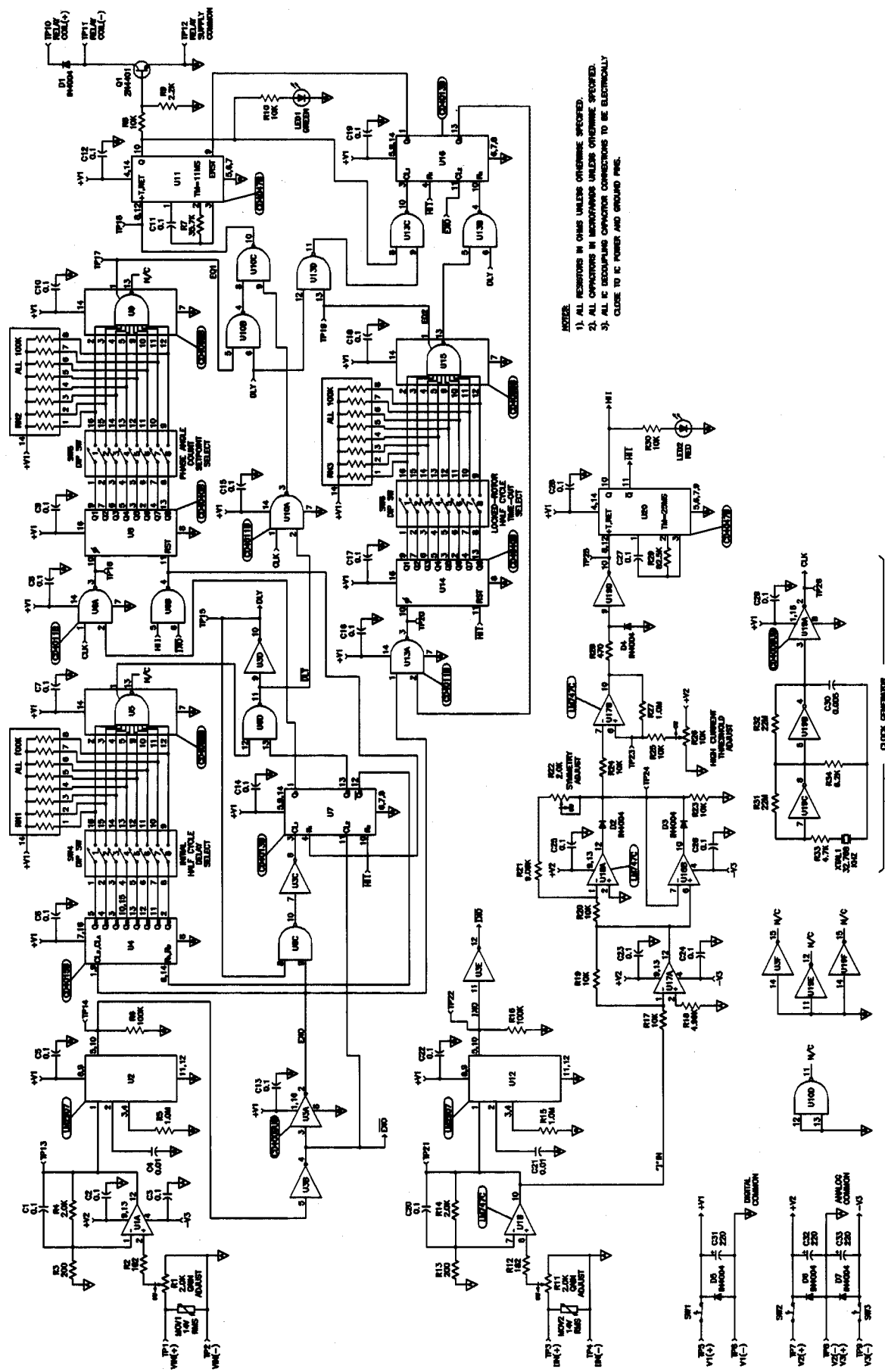

NOTE:  
 1. ALL RESISTORS IN OHMS UNLESS OTHERWISE SPECIFIED.  
 2. ALL CAPACITORS IN MICROFARADS UNLESS OTHERWISE SPECIFIED.  
 3. ALL IC SCHEMATIC SYMBOL CONNECTIONS TO BE ELECTRICALLY CLOSE TO IC POWER AND GROUND PINS.

Fig. 7. Prototype phase-angle detection circuitry (only one phase shown).

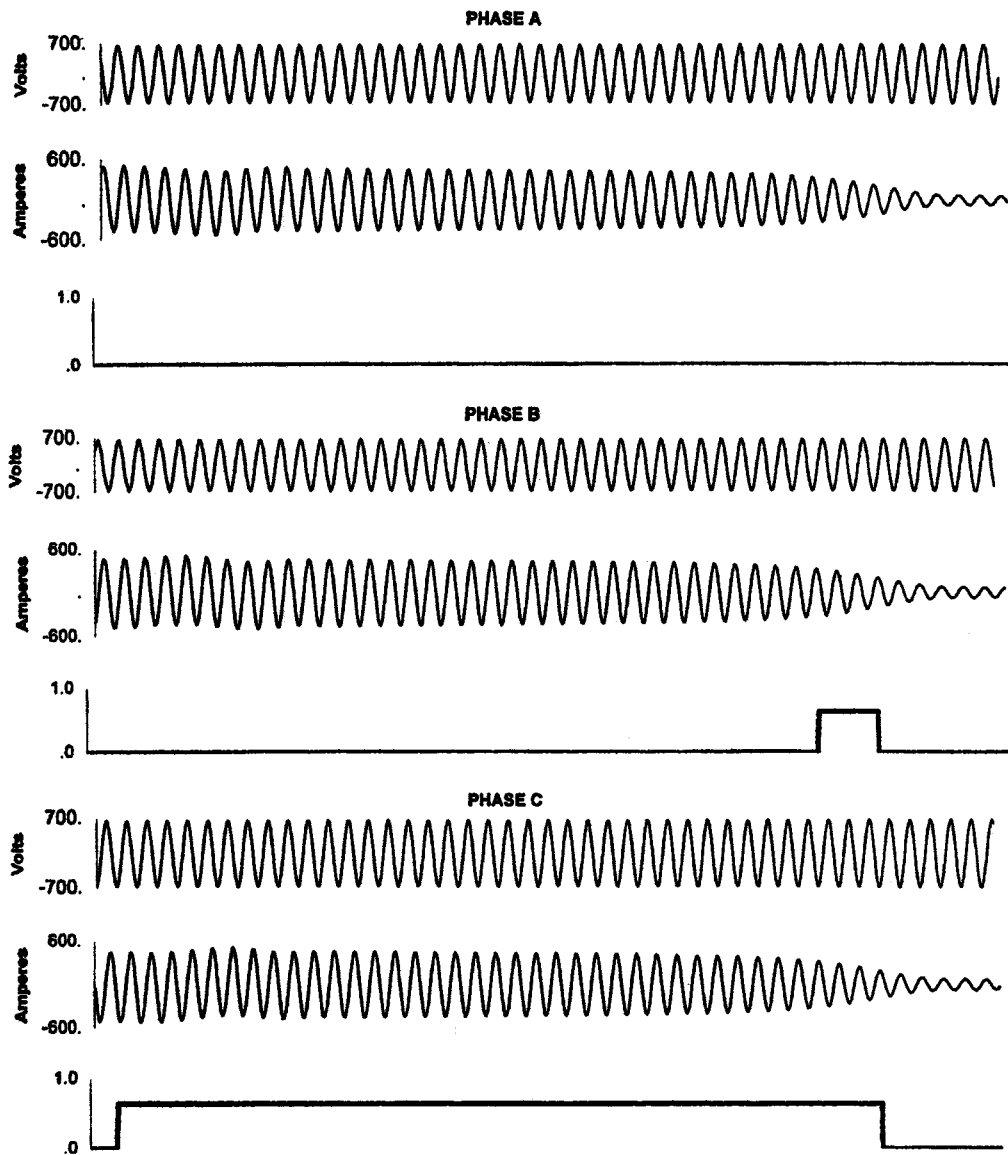

Fig. 8. Laboratory tests of prototype circuit with a 50-hp motor.

Throughout the startup of the motor, the phase voltages remained constant while the phase currents could be seen to decay toward running values. The motor phase angle of  $60^\circ$  is greater than the appropriate  $50^\circ$  setting of phase A, so the phase-A detection circuitry correctly identifies the input voltage and current waveforms as a motor start and inhibits the circuit breaker from activating. The angle threshold for phase C has been intentionally, but inappropriately, set at  $70^\circ$ . Since the motor's phase angle is less than this level, the phase-C detector circuit considers this a short-circuit event and outputs a signal to enable circuit breaker action. The angle detection level setting of  $60^\circ$  for phase B is close to the actual motor signal. Initially the motor's angle exceeds  $60^\circ$  and the detector correctly identifies the motor start and inhibits circuit breaker action. However, as discussed previously, motor phase angles can decrease slightly during starts. Apparently, after about 36 cycles (0.61 s), the measured angle drops below  $60^\circ$ , causing the detector output to send an enabling signal to the circuit breaker as long as the B current exceeds 300 A. It must be emphasized that in application the

phase-angle detection thresholds for all phases would be identical and fixed below the phase angle of the motor voltage and current. This level would be set by starting the protected motor a dozen times and adjusting the angle detection level. Nevertheless, should the detector output conflicting signals from two phases, the circuit breaker will always be allowed to trip. Conversely, to prevent circuit breaker action, inhibit signals must be outputted for all three phases.

### C. Application

The prototype detector can have utility on three-phase power systems where the starting of induction motors causes nuisance tripping of the short-circuit protection. In lieu of incorporating an intentional time delay or increasing the trip setting of the circuit breaker, the detector may be used to momentarily inhibit circuit breaker action during motor starts. It is envisioned that the detector would be located near the circuit breaker. The device would temporarily inhibit breaker action only if high phase

angles and high currents were indicated for all phases. It is recommended that the activation point of the current magnitude detector be adjusted to the required magnetic setting of the circuit breaker. Consequently, the device would remain inactive for currents less than the circuit breaker setting. When phase currents exceed this level, a built-in delay in detector activation would prevent false indications for the initial period of motor starts. Because the phase-angle characteristics of motors depend on motor voltage, class, manufacturer, and horsepower, presetting of the detector would be impractical. In application, the device activation point plus some margin would be determined by starting the protected motor a dozen times. This would account for any transients resulting from the randomness of the instant of energization relative to the voltage cycle.

## V. SUMMARY AND CONCLUSIONS

The NIOSH Pittsburgh Research Laboratory investigated electrical safety in coal mines through research into short-circuit protection of mine power systems. Voltage and current waveforms of mine induction motors were recorded during field tests, and their salient characteristics were evaluated. An attribute of motor-start signatures that distinguished them from short circuits was the relatively large phase angle between voltage and current. This was the focus of subsequent efforts to devise a means to discriminate between motor starts and short circuits. Electronic circuitry was designed to differentiate between phase angles associated with motor starts and faults and react to momentarily disable circuit breaker action for motor starts. A prototype was successfully evaluated with a three-phase induction motor in the laboratory.

By devising a method to distinguish between motor starts and short circuits, any intentional time delays in response to short circuits can be significantly reduced from up to 0.25 s to 66 ms. Rapid response to short circuits will help ensure that the surface temperatures of energized electrical apparatus will not exceed gas or dust ignition thresholds when such faults occur. In addition, the capability of differentiating motor starts from short circuits will preclude nuisance protective device activation. Ultimately, this work may result in revisions to high-voltage long-wall approval guidelines and improvements in circuit breaker designs. Moreover, the technology may be applicable to motor circuits at all voltage levels.

## REFERENCES

- [1] *Recommended Practice for Electric Power Distribution for Industrial Plants (IEEE Red Book)*, ANSI/IEEE Standard 141, 1993.
- [2] *IEEE Recommended Practice for Protection and Coordination of Industrial and Commercial Power Systems (IEEE Buff Book)*, ANSI/IEEE standard 242, 1986, p. 344.
- [3] C. M. Boring and K. J. Porter, "Criteria for approval of mining equipment incorporating on-board switching of high-voltage circuits," in *Proc. Ninth WVU Mining Electrotechnology Conf.*, Morgantown, WV, 1988, pp. 267–274.
- [4] *Code of Federal Regulations*, Office of the Federal Register, U.S. Government Printing Office, Washington, DC, <AUTHOR: YEAR?>.
- [5] J. E. DeCastro, R. T. Beck, C. Cai, and L. Yu, "Stall protection of large induction motors," *IEEE Trans. Ind. Applicat.*, vol. 31, pp. 1159–1166, Sept./Oct. 1995.
- [6] "Mine safety and health administration: Proposed rules," *Federal Register*, 57 Fed. Reg. 39036, 1992.

- [7] H. Lord H and F. K. Pearson, "Ultra-sensitive instantaneous fault protection for cage induction motor supplies," *Mining Technol.*, vol. 62, pp. 219–223, 1980.
- [8] L. A. Morley, J. N. Tomlinson, G. Moore, and D. E. Kline, "Portable trailing cables, splices, and couplers design and installation considerations," The Pennsylvania State Univ., University Park, PA, U.S. Bureau of Mines Contract J0199106, 1982.
- [9] L. A. Morley, T. Novak, and I. Davidson, "The application of 2,400 V to longwall face equipment," *IEEE Trans. Ind. Applicat.*, vol. 26, pp. 886–892, Sept./Oct. 1990.
- [10] J. M. Schulman, W. A. Elmore, and K. D. Bailey, "Motor starting protection by impedance sensing," *IEEE Trans. Power App. Syst.*, vol. PAS-97, pp. 1689–1695, <AUTHOR: MONTH?> 1978.



**Michael R. Yenchek** (S'70–M'71–SM'89) received the B.S.E.E. and M.S.E.E. degrees from the University of Pittsburgh, Pittsburgh, PA, in 1971 and 1977, respectively.

From 1971 to 1980, he was an Electrical Engineer with the Coal Mine Safety and Health Division, Mine Safety and Health Administration. In 1980, he joined the Pittsburgh Research Laboratory, U.S. Bureau of Mines (now National Institute for Occupational Safety and Health), Pittsburgh, PA, where he is currently the Chief of the Protective Equipment Section, Mining Injury Prevention Branch. He has been responsible for research programs concerning grounding and ground fault, dc haulage, motor, and trailing cable protection.

Mr. Yenchek is a member of Eta Kappa Nu and a Registered Professional Engineer in the Commonwealth of Pennsylvania.



**James C. Cawley** (M'82–SM'83) received the B.S.E.E. degree from The Pennsylvania State University, University Park, and the M.B.A. degree from the University of Pittsburgh, Pittsburgh, PA.

He designed vibration monitoring instrumentation for Reliance Electric Company, Columbus, OH, and industrial communications systems for Marshall Electronics Company, Pittsburgh, PA, prior to joining the Pittsburgh Research Center, U.S. Bureau of Mines, Pittsburgh, PA. In positions there as an Electrical Engineer and later as an Engineering Supervisor, he was active in the fields of intrinsic safety, explosion-proof enclosures, and mine electrical systems and diagnostic systems for mine machinery. Since the activities of the former U.S. Bureau of Mines were assumed by the National Institute for Occupational Safety and Health, he has worked on electrical safety issues related to overhead power-line contact with cranes and trucks and in the causal analysis of electrical incidents.

Mr. Cawley is a Registered Professional Engineer in the Commonwealth of Pennsylvania.



**Albert L. Brautigam** received the B.S. and M.S. degrees in electrical engineering from the University of Pittsburgh, Pittsburgh, PA.

He has more than 30 years of experience in the design of control, measurement, and data acquisition systems. He was a Research Engineer at the Graham Research Laboratory, Jones & Laughlin Steel Corporation, Senior Engineer for the Westinghouse Electric Corporation Water Reactors Division, and Specialist Engineer for Boeing Services International, Inc. Currently, he is an Electrical Engineer with the Pittsburgh Research Laboratory, National Institute for Occupational Safety and Health (formerly the U.S. Bureau of Mines), Pittsburgh, PA. He is responsible for the development of electronic control and measurement systems for mining equipment.



**Jeffrey Shawn Peterson** received the B.E. degree in electrical engineering from Youngstown State University, Youngstown, OH, and the M.S. degree from the University of Pittsburgh, Pittsburgh, PA, in 1987 and 1998, respectively.

Since August 1987, he has been with the U.S. Bureau of Mines/Department of Energy/National Institute for Occupational Safety and Health, Pittsburgh, PA. He has conducted research in a variety of mining areas, including the detection of downed trolley lines, short-circuit protection of high-voltage longwall circuits, and intrinsic safety. During the previous three years, his research focus has shifted to hearing loss prevention, in which area he has worked extensively in the areas of signal collection and analysis and engineering controls.