

# TECHNICAL REPORT

Final Report  
C5490

SAFE DISTANCES FOR BLASTING WIRING FROM  
COMMONLY ENCOUNTERED UNDERGROUND ELECTROMAGNETIC ENERGY SOURCES

by

Ramie H. Thompson

September 1983

Prepared for

U.S. Bureau of Mines  
Department of Interior  
Washington, D.C.

Contract No. J0328023



**Franklin Research Center**

A Division of The Franklin Institute

The Benjamin Franklin Parkway, Phila., Pa. 19103 (215) 448-1000

The views and conclusions contained in this document are those of the author and should not be interpreted as necessarily representing the official policies or recommendations of the Interior Department's Bureau of Mines or of the U.S. Government.

#### ACKNOWLEDGEMENTS

This project was ~~carried out~~ by personnel of the Applied Physics Laboratory of the Franklin Research Center. The mine measurements were carried out principally by the author, Mr. Ramie H. Thompson, Principal Scientist, Mr. James Stuart, Research Scientist, and Mr. A. W. Cipkins, Technical Associate.

Thanks are due to Messrs. Harry Dobroski and James Means of the U.S. Bureau of Mines in providing specialized equipment and actual help in the preliminary measurements.

## CONTENTS

<u>Section</u>	<u>Title</u>	<u>Page</u>
ABSTRACT		
ACKNOWLEDGEMENTS		
1.0	INTRODUCTION	
	1.1 Background	
	1.2 Early Efforts	
	1.3 Final Measurements	
2.0	MINE MEASUREMENT DESCRIPTIONS	
	2.1 The Mines and the Measurement Locations	
	2.2 Apparatus	
	2.3 Apparatus Check Out	
	2.4 Measurement Procedure	
3.0	MINE MEASUREMENT RESULTS	
	3.1 Loop Measurement Results	
	3.2 Transmission Line Results	
4.0	ANALYSIS OF MEASUREMNT RESULTS	
	4.1 Loop Data Analysis	
	4.2 Transmission Line Data Analysis	
5.0	CONCLUSION FROM MEASUREMENTS	
6.0	SAFE DISTANCES FROM SOURCES	
	6.1 Critical Values of the Field	
	6.2 Free Space Values of the Field From Various Sources	
	6.3 Safe Distances From Trolley Phone Line Conductors	
	6.4 Safe Distances From Loop Sources	
	6.5 Summary of Safe Distances and Comment	
7.0	REFERENCES	

## 1.0 INTRODUCTION

### 1.1 BACKGROUND

In many underground coal mining operations the use of electromagnetic field equipment, particularly communication systems, not only increases the overall efficiency of the mining operation but can be directly linked with mine safety considerations. The use of electromagnetic field producing equipment in underground coal mining operations can only be expected to grow. Several new communication systems have already been proposed. In addition, high-frequency producing equipments for many diverse uses in mining operations are under study.

The use of these equipment in underground mining operations is hampered by the possibility of their electromagnetic fields interacting with the electric blasting cap operations commonly carried out in the mines. Such interactions can have at least two results bearing directly on mine safety:

- o premature initiation of the cap, either in its normal shot location or during hookup or transportation;
- o dudding of the cap so that normal firing operations do not cause irritation, thereby leaving unexploded high explosives after normal firing.

Since the consequences of a premature initiation could, particularly in coal mines operations, result in catastrophe involving human life, the overall approach to prediction of possible hazard must be, as far as possible, of a "worst case" nature.

The general problem of predicting possible RF hazards for any electroexplosive device (EED) is best treated by reference to Appendix A of

this report. Appendix A considers the general problem from a military/space agency viewpoint but blasting caps are the primitive models for most EEDs so the material is directly applicable to blasting cap problems.

In brier, the specific problem of analytically predicting possible RF hazards to blasting caps can be reduced to finding answers to the following three questions:

- (1) How much power, at the frequency of concern, is necessary to function the cap?
- (2) How much power is coupled to the cap by a given field existing in the vicinity of the cap and its associated wiring?
- 3) What fields will exist in the vicinity of the blasting cap and its wiring for a given source, physical environment, frequency and separation?

A considerable body of work<sup>1,2,3</sup> exists that deals with questions (2) and (3) for aboveground blasting operations and sources. Although some of the results of this work are directly applicable to underground mining operations, the factors of minimum distance between transmitting sources and caps, tunnel geometry, unknown electrical properties of the surrounding minerals, etc., that are inherent in underground operations limit complete application of these methods and results. Some limited theoretical investigations<sup>4,5</sup>, tailored to a specific underground communication system, have been performed. In the end, electromagnetic hazard evaluation of the system was forced to rely on experimental data taken in a tunnel of the mine in which the communication system was to be installed.

Under the U.S. Bureau of Mines Contract HO210068 The Franklin Institute undertook a program aimed at producing a worst case model for electromagnetic energy/blasting cap interactions in underground workings. The results were presented in FIRL Report F-C3102, "Evaluation and Determination of Sensitivity

---

<sup>1</sup>Superscripts refer to numbered references of Section 7.

of Electromagnetic Interactions of Commercial Blasting Caps."<sup>6</sup> R.H. Thompson, August 1973.

The experimental program showed that, for blasting caps of American manufacture, the application of 40 mW of average RF power, either continuous wave or with a typical radar pulse signature, to the input impedance of the cap, either pin-to-pin or pin-to-case, could be expected to result in an initiation less than once in one thousand applications with a 95% confidence level. Thus the use of a 40 mW "no-fire" level for underground caps, a level that had been tentatively established for all American-made blasting caps, was confirmed.

Under U.S. Bureau of Mines Contract HO252015, the Applied Physics Laboratory of The Franklin Research Center undertook measurements in coal mines that, coupled with the 40 mW "no-fire" level, previously developed worst case wiring pick up antenna models, published electromagnetic mineral parameter data and a "lossy layer" model for propagation in the mine, could be used to predict safe distances for blasting operations underground. This work is reported in "RF Hazards to Blasting Caps in Coal Mines."<sup>7</sup> The predicted safe distances in that report for frequencies less than 10 MHz were quite large. They are given in Figure 1-1. This was the direct result of the demonstration by our measurement results that, at these frequencies, underground sources coupled well to longitudinal conductors along the drifts. Thus, the energy from the source could propagate long distances with relatively small attenuation. The analyses assumed a large coupling factor between the source and any nearby conductors, thus large values of the fields were predicted at very large distances. We recognized at the time that the assumption of very good coupling between the source and the conductors in the mine was in error but the measurements taken provided no way to produce a valid worst case estimate of smaller magnitude.

The present project is aimed directly at this difficulty. Our overall effort was directed at source frequencies of 10 MHz, or less. In this frequency regime coupling between the source and the blasting cap can be considered to be completely by magnetic induction. If the magnetic field,  $B$ , is known in the vicinity of the blasting wiring, then an upper limit on the

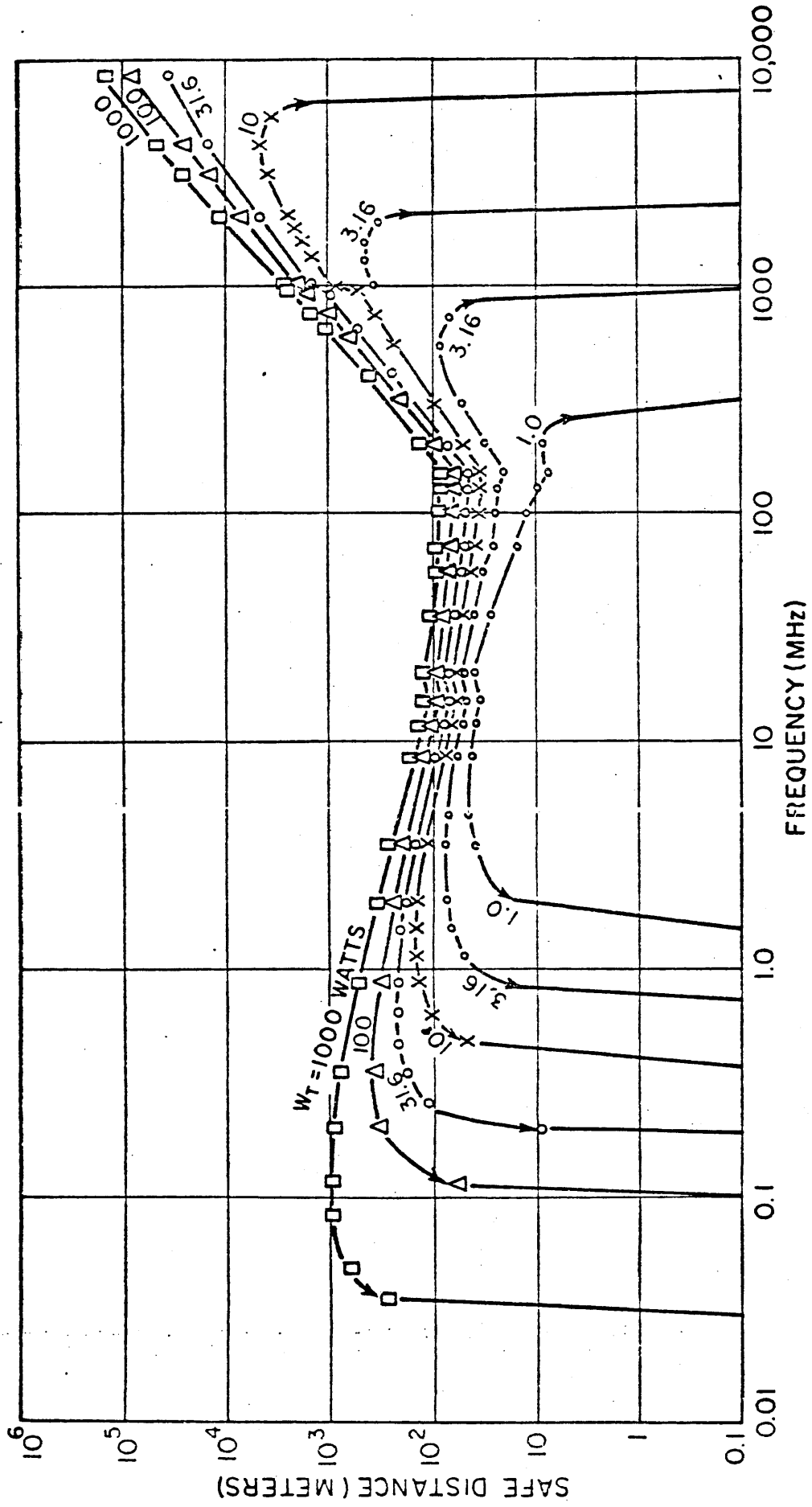

Figure 1-1 Safe Distances



power absorbed by a blasting cap in the wiring can be made. Since the magnetic field can be thought of as having its source in currents driven by electromagnetic equipment, and these equipments can be related to the maximum currents they can produce, we see that a knowledge of the B field in the vicinity of known currents would allow us to predict safe distances for these currents. The experimental work on this project was directed to determining the B field distribution around typical underground current carrying conductor configurations.

In particular, we chose loop current sources to approximate the "back pack" antennas and bandolier antennas being used for communication in coal mines. We also made measurements on a configuration approximating the conventional trolley line communication systems.

Our overall measurement scheme was guided by the following approach to computing safe distances in the frequency band below 10MHz.

The maximum voltage induced in a loop of blasting wiring containing a cap can be written as

$$V_R = \int_A \frac{\partial B}{\partial t} \cdot dA \quad (1-1)$$

where  $V_R$  is the RMS open circuit voltage (volts)

$B$  is the RMS magnetic field (maxwells)

linking the loop and

$A$  is the area of the loop (meters<sup>2</sup>)

Total worst case power to the cap ( $W_R$ ) is

$$W_R = \left| \frac{V_R}{Z_b} \right|^2 R_{dc}$$

where  $W_R$  is the worst case power (watts), and  $Z_b$  is the total impedance of the cap, and

$R_{dc}$  is the resistance of the cap --

about 1 ohm.

If the received power is less than 40 milliwatts, we assume the cap is safe in its environment. Now, we could easily compute B at the blasting

wiring location if we knew the direction, magnitude and location of all driven currents in the vicinity and the overall conductor configuration were located in free space. The actual fact is that the driven currents exist underground and there are other conductors present in the mine. The direction, magnitude and location of the driven currents can be estimated -- in a worst case sense -- from the equipments used in the mine and the conductors they drive, thus we need a correction factor that can be applied to the free space calculation of the B field that compensates -- in a worst case sense -- for the presence of the additional conductors in the mine and the presence of the minerals that make up the overall mine environment.

The determination of such a correction factor was the object of our measurements.

## 1.2 EARLY EFFORTS

Various loop antennas and transmission line simulating antennas were employed in late 1981 in a gallery of the U.S. Bureau of Mines Bruceston experimental mine. Measurements were taken of the variation of magnetic field with distance from the known currents in the transmitting antennas. The measurements, as expected, showed values larger than those predicted from free space calculations. The various conductor locations -- metal roof mesh, water pipes, electrical conduit, pipes, etc. -- were closely determined in the mine. A complete mockup of the mine -- constructed of wooden 2x4's was erected in an open field in Millville, N.J.

All conductors were simulated in this mockup. The overall idea was to determine if the conductors or the minerals of mine contributed most to the elevated B field measurements obtained in the actual mine. Hindsight is much better than foresight. We found our aboveground measurements to be completely useless. All our measurements were contaminated by large pickups -- large in relation to our previous measurements -- from AM & FM radio stations, even though these stations were many miles away. In the main, this entire result

was due to the fact that the 300 foot long conductors were excellent antennas for the commercial radio stations.

This entire phase of our effort provided no insight into our problem but did produce improvements in our source equipment and measurement techniques.

### 1.3 FINAL MEASUREMENTS

The measurements presented herein were aimed at the determination of B field variation -- in coal mine settings -- from known straight line and loop driven current sources. The measurements were performed at three locations in each of three mines. The individual locations were selected to provide a wide variation in local conduction density and degree of wetness.

## 2.0 MINE MEASUREMENT DESCRIPTIONS

### 2.1 THE MINES AND THE MEASUREMENT LOCATIONS

The measurements were performed in two mines in New Raton, New Mexico and a mine in Ashland, PA. In the data presented the measurement locations are given by a number 1 to 9.

#### The York Canyon Mines

Two underground coal mines called respectively "Main" and "Central" are in York Canyon near Raton, New Mexico. Franklin Research Center personnel made electromagnetic measurements in three locations in each of these two mines. The mines were temporarily shut down at the time of measurements with only maintenance and supervisory personnel present.

The mines are owned by the Kaiser Steel Co. The cooperation of the following people, among others, was greatly appreciated: Mr. Harry Elkin, Manager; also Fred Revera, M.A. Bertola, Paul Starkovich and Joe Romero. Help and hospitality from Mike Sepich and Larry Stolarczyk of A.R.F. Products Incorporated, manufacturers of mine-communications equipment, is also acknowledged.

- (1) Location 1 was in York Canyon Main Mine, number nine left intake, in front of the entrance to cross-cut thirty-six. This was a dry location. Density of metallic conductors present was high. A three-inch steel water-pipe ran along one wall along with many heavy electric cables. Thin steel plates called "mats", approximately fifteen inches wide by fifteen feet long, with their long dimension oriented across the tunnel, were bolted to the roof at four-foot intervals. The circular antenna loops were hung with the top of the loop approximately eighteen inches below the roof. This location was about three miles in from the mine portal and close to a long-wall continuous-mining apparatus.

- (2) Location 2 was not far from the previous location: York Canyon Main Mine, number nine left intake, in crosscut twenty-seven. This was a dry location. Density of metallic conductors present was medium. There was just one electric cable hung along the side of the crosscut, and no pipes. There were steel mats on the roof like those described previously. Transverse steel I-beams were used as roof supports. The antenna-loop was hung with its top two feet below the roof.
- (3) Location 3 was York Canyon Main Mine, number nine left intake, in crosscut 26. This was a dry location. Density of metallic conductors present was low. There were no cables or pipes running along the side of the crosscut. Steel mats were on the roof in an irregular pattern. The roof was held up by steel I-beams going from one side of the crosscut to the other, supported at the ends by sturdy wooden posts. These I-beams were about eight feet apart. The loop antenna was hung so its top was about two feet below the roof, in a spot fourteen feet into the crosscut from the place where it opened into the haulageway. Thirty feet from the loop in the other direction was a concrete-block wall with a small door leading to a beltway.
- (4) Location 4 was York Canyon Central Mine, main intake, first south, in the haulageway between crosscuts eleven and twelve. This was a dry location. Density of conductors was medium. There were two three-inch-diameter high-voltage electric cables running along the side of the tunnel; these were the only longitudinal conductors. Steel I-beams ran across the roof every eight feet, supported by vertical logs at the tunnel sides. Between these I-beams were one or two of the "mats" described previously, running across the tunnel and bolted to the roof. The antenna-loop was hung with its top three feet below a roof mat, in the center of the haulageway.

- (5) Location 5 was York Canyon Central Mine, first south intake, near crosscut thirteen. This was a wet location. Density of conductors was high. Because this was close to the face there were a great many longitudinal conductors, pipes and electric cables running along the sides of the tunnel. The roof, about five feet five inches high, was steel mats, oriented transversely, bolted to the roof, spaced about four feet apart. There were steel I-beams running across the roof, supported by vertical logs at the ends. These I-beams were about twenty feet apart in this tunnel. The floor was covered with puddles. Our radiofrequency apparatus was put onto duckboards. The roof dripped water everywhere. Icicles up to three feet long hung from the roof; we had to clear a small space through the icicles so we could set up the antennas to make measurements. The loop antenna was hung with its top approximately eighteen inches below the roof, one foot away from a steel I-beam which was at roof-level.
- (6) Location 6 was York Canyon Central Mine, first south intake, in the haulageway near crosscut twelve. This was a wet location. Density of conductors was medium. The only longitudinal conductors were a few electric cables and a telephone wire. There were puddles all over the floor. Water dripped from many places on the roof, and icicles hung all around. The steel roof mats were like those in location 5.

#### Pioneer Tunnel

This is a 70-year-old coal mine in Pennsylvania's anthracite region. The mine has three levels, three hundred vertical feet apart. All the tunnels have steel rails on the floor, and many places have electricity and compressed-air pipe. The mine was not operating, i.e. not producing coal at the time we were there. The

author would like to express their gratitude to George Staudenmeier, manager, and to William Whyne, foreman.

- (7) Location 7 was the so-called Little Buck Gangway. There were steel rails underfoot. Two wires ran overhead, along the center of the tunnel, attached to insulators nailed to logs or to the roof. Those were the only conductors present except for water, which dripped slowly from many places on the roof, but did not form puddles on the floor. The "Little Buck" vein of anthracite coal was two or three feet wide and slanted up at about a forty-five-degree angle. Above and below this vein were layers of hard rock. The bottom layer of rock had been blasted and excavated to make the tunnel. It was ten feet wide, with a horizontal floor and a smooth, sloping rock roof which was nine feet from the floor at its highest point. The vein of coal could be seen clearly. It continued up on one side, and down on the other side of the tunnel, parallel with and just below the tunnel's slanted rock roof. In most places no roof-supports of any kind were necessary. Infrequently (about fifty-foot intervals) there were a few vertical logs at the walls, and horizontal logs across the top, to give support at places where a chute led into this gangway from levels further up. The transmitting-loops for our measurements were hung with their centers about five feet from the floor, in the middle of the tunnel.
- (8) Location 7 was called "West number two Buck Mountain Gangway." There were no conductors at all here. The rails and electric wires had stopped farther back, and the roof did not drip water. The roof was twelve feet off the floor at its highest point, sharply slanted over a two-foot-wide coal seam. At the end of the gangway, where we were, the coal seam pinched down to one foot wide. In other respects this location was like the one described above. The transmitting coils were hung with center approximately four-and-a-half feet above the floor, in the center of the tunnel.

- (9) Location 8 was called "West Orchard Gangway." The roof dripped much water, and there were puddles on the floor. There were rails underfoot, and spare rails, pipes, tools and metal cans were stacked against the wall. This gangway had logs against the walls about every two feet, supporting horizontal logs overhead. Evidently the roof here needed more support than the roof in the other two gangways where we took data. This gangway was about ten feet wide, seven feet high, and seventy feet long. The transmitting coils were hung about twelve feet from the face at the end of this gangway. The gangway ended abruptly at a face or vertical wall where the coal seam, three feet wide here and tilted up at forty-five degrees, could be seen clearly in cross-section.

## 2.2 APPARATUS

Measurement of the B field was performed using a loop antenna source at frequencies of approximately 0.175, 0.5, 1.0, 5.0 and 10.0 MHz in each mine location. Measurements were also made using a rectangular loop 1 by 10 meters at approximate frequencies of 0.175, 0.5 and 1.0 MHz.

All loops were one-half meter in diameter. At the lower frequencies (175 KHz, 500 KHz, 1 MHz) a loop with fifteen turns was used, with appropriate matching-circuits which were different for each frequency. At 5 MHz a two-turn loop was used, and at 10 MHz a one-turn loop. Typical total antenna currents (number of turns times current) were up to six amperes.

Current flowing in the antennas was measured by a clip-on current probe, Hewlett-Packard type 1110A. Peak-to-peak current, displayed on the oscilloscope described below, was entered by hand in a notebook. The transfer impedance of this current probe was 1 ohm, so that voltages displayed on the oscilloscope were of equal magnitude to currents enclosed by the probe jaws.



The mobile transmitter which drove the antennas consisted of a low-power oscillator (General Radio 1211-B serial number 1215, or Hewlett-Packard 204B serial number 416-08150) and a 35-watt RF power amplifier (E.N.I. 440LA serial number 141).

The electromagnetic-field sensor consisted of a one-turn pickup loop of 10 cm diameter, with a 160-ohm load paralleled by the 50 ohm measurement cable leading to the oscilloscope. This small size and low "Q" eliminated resonance effects over the entire frequency band of interest. The coaxial cable, terminated in its characteristic impedance, carried the pickup signal without reflections to a small battery-powered oscilloscope (Leader LBO-308S, serial number 1080193). Peak-to-Peak voltage, displayed on this oscilloscope, was entered by hand in a notebook.

The low-frequency transmitting-antenna, a 15-turn loop, is shown in Figure 2-1. Figure 2-2 shows the apparatus for measurement of RF current on the single-turn 10-MHz loop.

The rectangular loop or long wire antenna was one meter high and ten meters long, with the lower conductor right on the ground or floor of the tunnel. This long-wire running down the center of the tunnel was intended to serve as a model or mockup of a trolley wire carrying radiofrequency signals. The RF magnetic field was then measured at points near the center of this wire, far enough from the ends that this mockup might be approximated theoretically by a wire of infinite length carrying uniform current. Naturally this long-wire could only be used at the lower frequencies (0.175, 0.5, 1 MHz) where the current was approximately uniform over its length. The B field measurements were made using the same 10 cm probing loop described above. Preliminary measurements were made to insure that the current in this loop was approximately uniform.

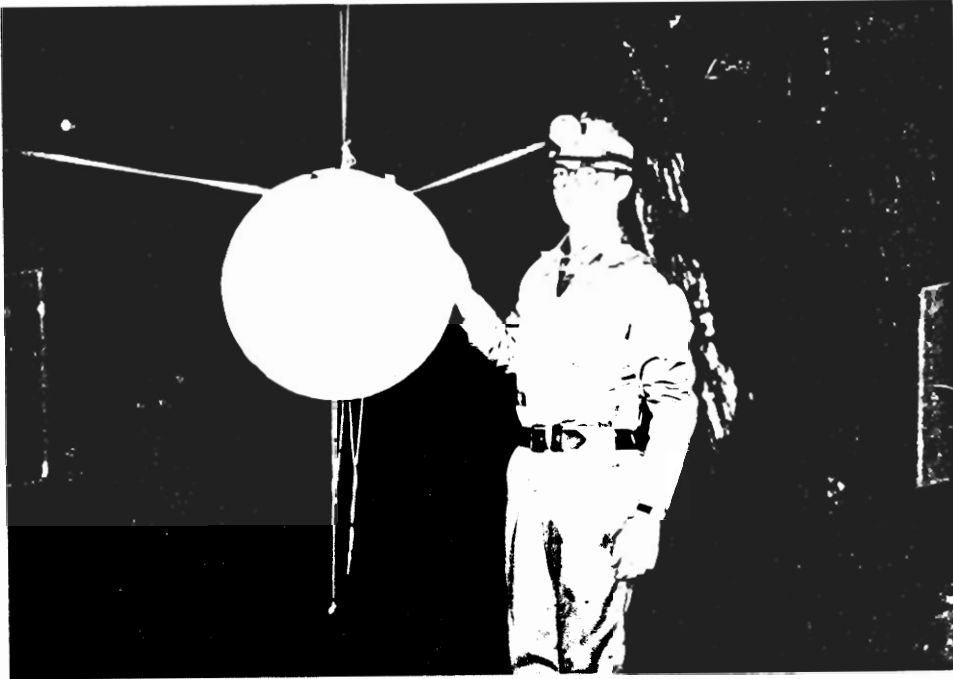

Figure 2-1 Low-Frequency Transmitting Antenna



Figure 2-2 Measurements of 10-MHz RF Current

### 2.3 APPARATUS CHECK OUT

In order to determine if the source antennas and the measurement apparatus were functioning properly we performed all anticipated measurements aboveground in conductor free environments. These check out measurements were performed on an open field here in Philadelphia outside our laboratory and again on the grounds of the Bruceston experimental mine.

The pickup results were very close to those calculated by free space assumptions.

### 2.4 MEASUREMENT PROCEDURE AT EACH MINE LOCATION

A circular loop antenna was hung in the center of the tunnel, at eye level, with its axis pointing along the tunnel. Current in the loop was driven by the transmitter set to that antenna's tuned frequency. Loop current was measured by the current probe. The strength of the radiotrequency magnetic field was first measured at points along the axis of the loop, and then at points in the plane of the loop. Approximately twenty-four measurements were made, at distances up to three meters from the center of the loop. This was a practical limit because at greater distances the signal level was generally too low to measure.

Then the loop was rotated so its axis pointed across the tunnel. This was important because we expected the tunnel-loop coupling to be dependent upon the relative orientation of the loop and the tunnel. Another twenty-four measurements were then made like those described above.

Having thus finished with the first frequency, the loop antenna was exchanged for another one, tuned to another frequency, and the whole procedure described above was followed again. In all, data was taken at five frequencies (approximately 0.175, 0.5, 1, 5, 10 MHz) in each mine location.

After the loop measurement the long-wire antenna was set up. The wire was suspended on wooden forms so that it was 1 meter above the flow for its 10 meters of length. The rectangular loop was driven by the same transmitters used for the circular loops and current in the source loop measured with the current probe. The magnetic field was measured at a point 5 meters (half way down) from the driven end at heights of 0.5 and 1.0 meters at various distances from the plane of the rectangular loop. Measurements were carried out at approximately 0.175, 0.5 and 1.0 MHz.

Note that all data were recorded for B field measurements as millivolts -- (peak-to-peak) displayed on the oscilloscope. All source antenna currents were also recorded as total amps (number of turns times current, peak-to-peak) so that no conversion from RMS to peak-to-peak was needed for our calculations.

### 3.0 MINE MEASUREMENT RESULTS

#### 3.1 LOOP MEASUREMENT RESULTS

The raw loop data is given in Appendix B. The loop is always assumed to be in the X,Y plane with the axis of the loop perpendicular to this plane. Further, the loop is assumed to be suspended along the Y axis. Thus if the axis of the loop is pointed along the drift, Z is measured along the drift from the center of the loop. X is then measured to the drift wall from the center of the loop. This orientation, with the axis of the loop in the direction of the drift axis is referred to in Appendix B as direction 1.

Direction 2 is associated with the axis of the loop pointing to the drift wall. In this case also X and Z are defined as above. Thus, the X,Y,Z coordinate system is associated with the loop, not its orientation in respect to the tunnel.

In particular, if  $X=0$  for a data point, then the measurement is at a point along the axis of loop and if  $Z=0$ , the measurement point is in the plane of the loop. Note that both X and Z values can be greater than or less than zero. Measurements were made in both directions along the axes.

In Appendix B the column headed "Current" gives the total (number of turns times single turn current) current in the source loop, the column headed "Pickup" is the peak-to-peak voltage recorded from the oscilloscope connected to the 10 cm search coil.

The order of measurements in Appendix B is the Actual order in which the measurements were taken.

#### 3.2 TRANSMISSION LINE RESULTS

Appendix C gives all the raw data for the transmission line measurements. Notation is the same as in Section 3.1; note that here,

however, we have no direction notation since the long line always runs down the drift. The coordinate system is a bit different here. With the transmission line measurement data were always taken at the midpoint of the line with the two dimensions taken as vertical height from the floor (Z). The Y direction is measured toward the mine wall from the middle of the drift (the location of the transmission line). A sketch of the coordinate system is given as the first page of Appendix H.

## 4.0 ANALYSIS OF MEASUREMENT RESULTS

### 4.1 LOOP DATA ANALYSIS

The raw data listing of Appendix B is difficult to interpret even if exactly the same frequencies were used at each location and exactly the same loop source currents were obtained. In order to compare the results at differing locations we have lumped all frequencies that are close together, e.g. all 0.173, 0.174 and 0.175 frequencies can be lumped together for clarity. Also, we expect all results of these experiments to be linear in relation to source current. Therefore, all source currents can be normalized to a single value if the "pickups" are changed by the same factor. Applying these rules and normalizing all the data to a 10 ampere source current we have plotted the results for all frequencies (1.73, 0.5, 1.0, 5.0 and 10.0 MHz) for both possible directions of the loop axis and for both X=0 and Z=0 data. These plots are given in Appendix D. Note that some individual curves show a sawtooth pattern. This is the result of our plotting both the result at a negative coordinate and a positive coordinate at the same positive value of the coordinate. Each individual curve on a given graph thus presents all data for a single location and direction along the indicated coordinate.

The curves of Appendix D, then, present a good visual picture of the variation from location to location for the same conditions. Our overall interest is in determining how far our measurement data deviates from a computed free space value. The free space values of induced voltage in a 10 cm diameter loop at various distances from a 0.5 meter loop along both the X and Z axes can easily be computed for a frequency of 1 MHz. These data are shown in Figures 4-1 and 4-2. Note that Figure 4-1(b) expands 4-1(a) at the 1 meter point where our first data point in the Z direction was taken. Figure 4-2 provides the same data for the X direction. Figures 4-3 and 4-4 present the same data in tabular form. Thus, we know the calculated data for all the data points at 1 MHz.

The pickup values at all frequencies are assumed to be proportional to  $\frac{df}{dr}$ , thus all pickups can be scaled to any other frequency. For the 10 MHz data we can simply divide the measured pickup by 10 to scale it to 1 MHz. Appendix E presents all the loop data scaled to 1 MHz and 10 amperes source loop current. It also presents the free space calculated value for data and the ratio of measured over calculated values. This ratio of measured to

Figure 4-1(A) Calculated Z pickup

F-C5490

DRIVEN LOOP: R= 0.250 I= 10.000 CENT 0.0 0.0 0.0 AXIS 0.0 0.0 1.0  
 PKUP LOOP R= 0.050; PICKUP VRS DISTANCE FROM LOOP CENTER: FMZ= 1.00

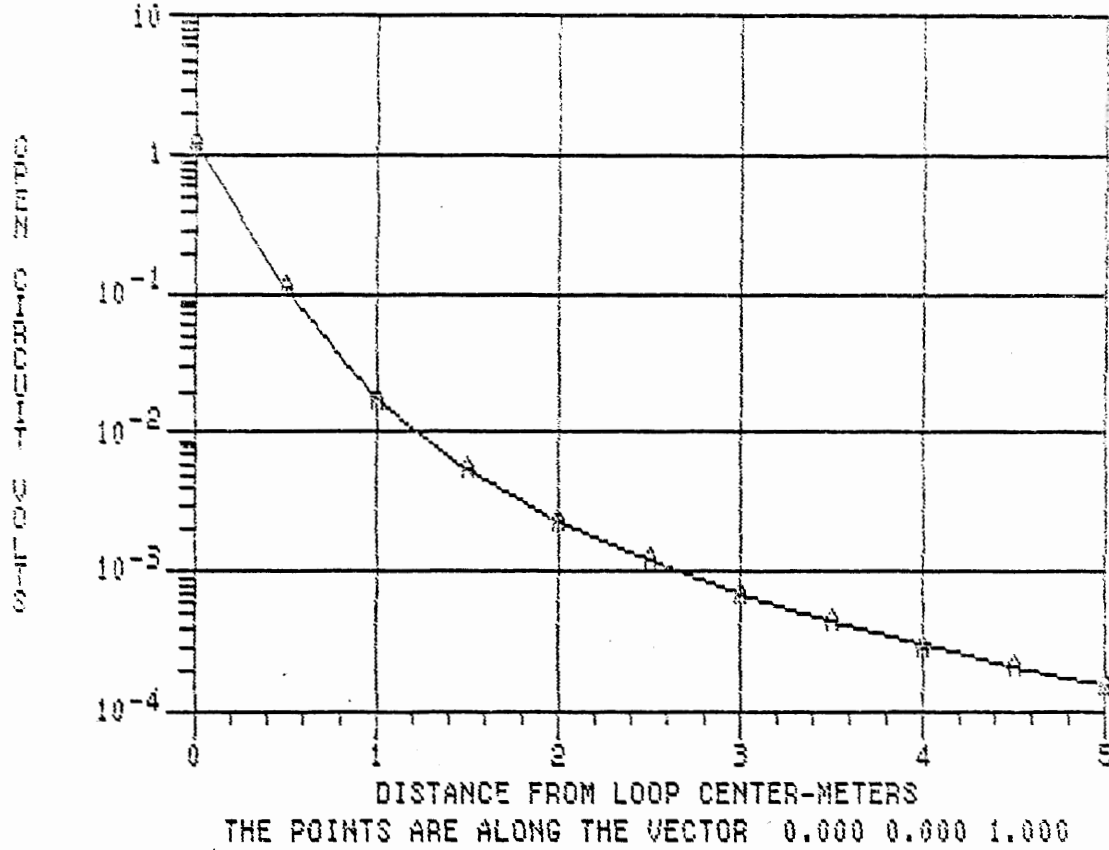
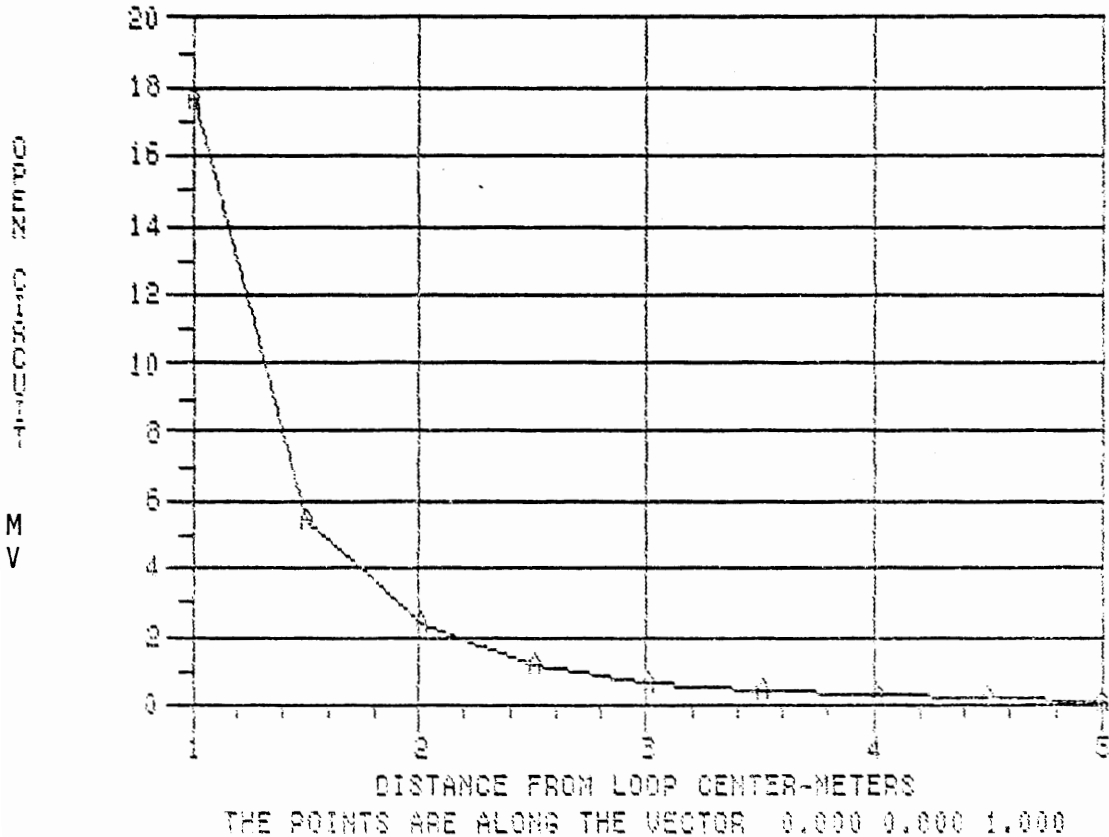

Figure 4-1(B)

DRIVEN LOOP: R= 0.250 I= 10.000 CENT 0.0 0.0 0.0 AXIS 0.0 0.0 1.0  
 PKUP LOOP R= 0.050; PICKUP VRS DISTANCE FROM LOOP CENTER: FMZ= 1.00





DRIVEN LOOP: R= 0.250 I= 10.000 CENT 0.0 0.0 0.0 AXIS 0.0 0.0 1.0  
 PKUP LOOP R= 0.050: PICKUP VRS DISTANCE FROM LOOP CENTER: FMC= 1.00

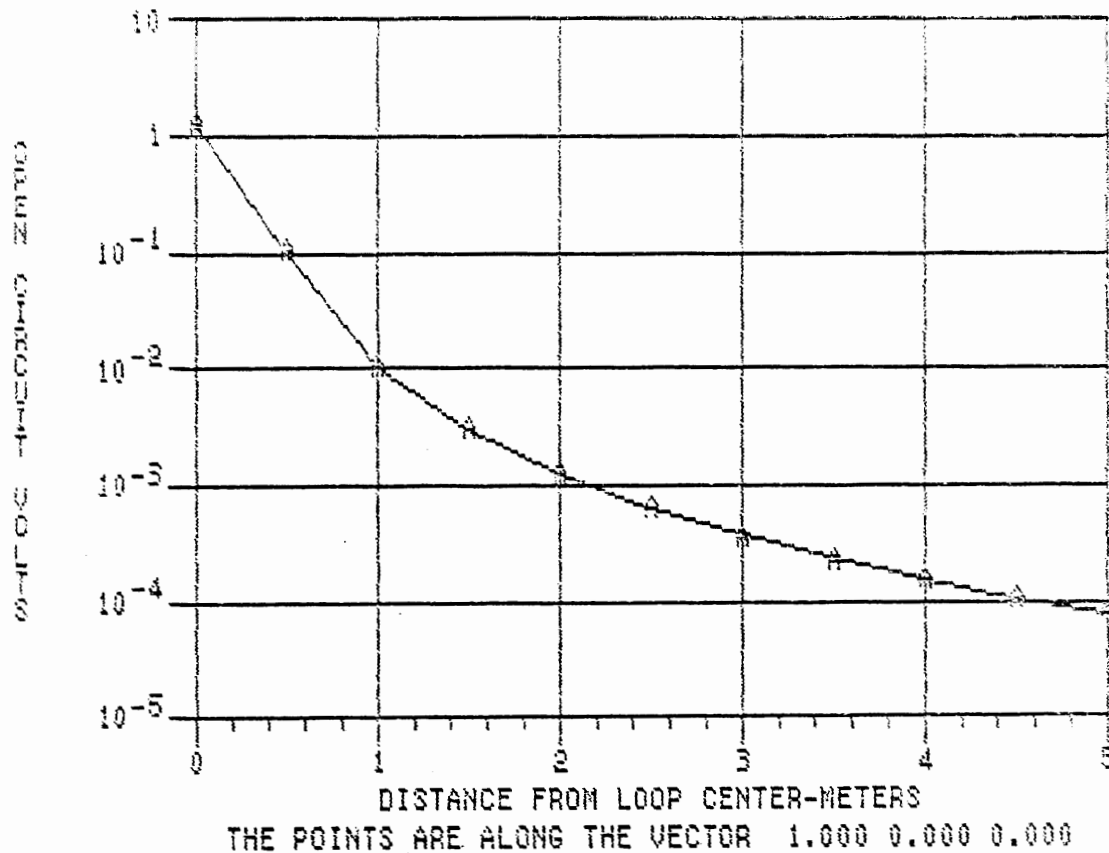

DRIVEN LOOP: R= 0.250 I= 10.000 CENT 0.0 0.0 0.0 AXIS 0.0 0.0 1.0  
 PKUP LOOP R= 0.050: PICKUP VRS DISTANCE FROM LOOP CENTER: FMC= 1.00

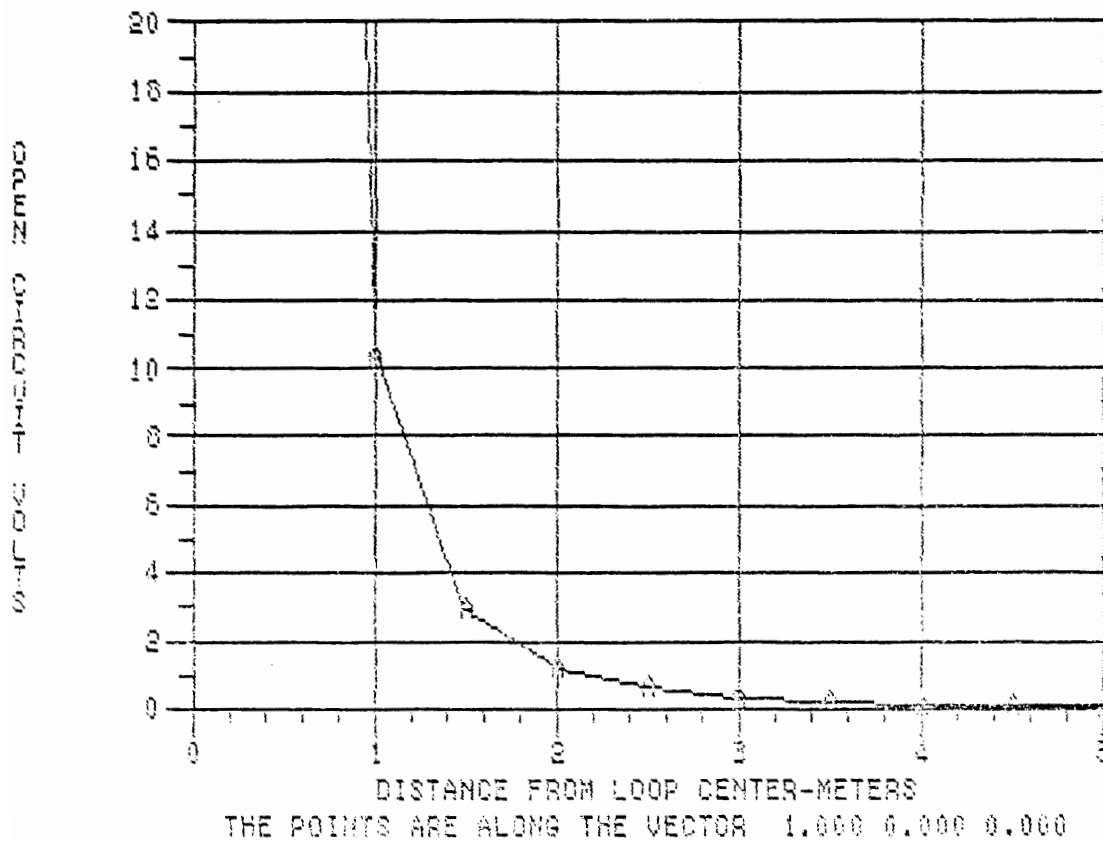

COMPUTED PICKUP FOR A 0.5 CM RADIUS LOOP  
SOURCE CURRENT IS A 10 AMPERE LOOP OF 0.25 M

DISTANCE Z (METERS)	PICKUP (VOLTS)
0.000000	1.240850
0.500000	0.106922
1.000000	0.010413
1.500000	0.002961
2.000000	0.001231
2.500000	0.000626
3.000000	0.000361
3.500000	0.000227
4.000000	0.000151
4.500000	0.000106
5.000000	0.000077

Figure 4-4

COMPUTED PICKUP FOR A 0.5 CM RADIUS LOOP  
SOURCE CURRENT IS A 10 AMPERE LOOP OF 0.25 M

DISTANCE X (METERS)	PICKUP (VOLTS)
0.000000	1.240850
0.500000	0.110916
1.000000	0.017693
1.500000	0.005512
2.000000	0.002368
2.500000	0.001223
3.000000	0.000711
3.500000	0.000450
4.000000	0.000302
4.500000	0.000213
5.000000	0.000155

calculated values is precisely the "correction factor" mentioned in the Introduction.

Comparison of data from location to location or direction to direction is difficult in Appendix E. Figure 4-5 gives a breakdown of the ways the ratio of measured to calculated pickup vary with direction. Here, all measurements along a given axis, at a given frequency, are lumped together. Note the figure suggests that changing the direction of the loop axis has only a small effect on the data obtained.

Figure 4-6 gives much the same data as 4-5 but here direction of the axis is ignored.

Figure 4-7 breaks down the variation in the ratio for each measurement distance and direction. Note that high values of the ratio seems to be associated most frequently with high values of X or Z.

Appendix F investigates this association in detail. Here, each ratio larger than 2, 3, 4, 5 ... is listed so that distance, location, direction can all be evaluated. There were approximately 193 data points taken at each location. Study of Appendix F shows that these were 294 points greater than 2. Of these, 103 occurred at Location 5 -- our most conductor rich location. Study of the locations and conditions for values of the ratio greater than 5 shows that there were 29 such values and, of these, only 3 occur at distances less than 2.5 or 3 meters. At these distances (2.5 and 3 meters) we are close to our noise level and small changes in field can make large changes in our ratio. Also, note that 16 of the 29 values are from location 5 and location 1 -- our high conductor density locations.

For ratios equal or greater than 7 all 10 occur close to the wall of the drift -- except one occurring in location 5. The values of the ratio greater than 8 all show the same pattern. We checked these against the data notebook and some show marginal notations showing that they were taken close to conductors.

Figures 4-8 and 4-9 are bar graphs of the occurrence of various values of the ratio on differing scales. We see that we had only 39 of 1744 occurrences of the ratio larger than 5 -- approximately 1.7% -- and it seems that most of these are associated with measurements close to conductors and relatively far (2 to 3 meters) from the source loops.

Figure 4-5

F-C5490

RATIO OF NORMALIZED DATA TO COMPUTED VALUE  
FOR THE DATA NORMALIZED IN FREQUENCY AND DRIVE CURRENT  
TO 1 MHZ AND 10.0 AMPS

WITH X=0.0 AND DIRECTION= ALONG THE DRIFT

FREQ(MHZ)	PICKUP RATIO			# OF ITEMS	SIGMA
	MAX	MIN	AVG.		
.173	2.4	.7	1.4	99	.3
.530	5.4	.1	1.6	107	.9
1.000	2.7	.5	1.3	108	.3
5.000	2.7	.6	1.3	81	.4
10.000	3.7	.4	1.4	104	.6

NOTE THAT SIGMA (S) IS COMPUTED FROM:

$$S^{*2} = (1/(N-1)) * (\text{SUM}((X-\text{MEAN})^{*2}))$$

WHERE: N=# OF ITEMS; X IS PICKUP; AND MEAN IS THE MEAN OF THE PICKUPS

WITH X=0.0 AND DIRECTION= ACROSS THE DRIFT

FREQ(MHZ)	PICKUP RATIO			# OF ITEMS	SIGMA
	MAX	MIN	AVG.		
.173	2.0	.5	1.2	85	.3
.530	4.8	.9	1.7	88	.8
1.000	4.1	.4	1.6	87	.7
5.000	4.2	.6	1.4	67	.5
10.000	3.5	.6	1.4	66	.5

WITH Z=0.0 AND DIRECTION= ALONG THE DRIFT

FREQ(MHZ)	PICKUP RATIO			# OF ITEMS	SIGMA
	MAX	MIN	AVG.		
.173	3.2	.8	1.7	71	.4
.530	7.1	.7	2.0	87	1.3
1.000	2.8	1.0	1.6	85	.4
5.000	8.0	.4	1.9	63	1.2
10.000	13.0	.4	2.9	92	2.4

WITH Z=0.0 AND DIRECTION= ACROSS THE DRIFT

FREQ(MHZ)	PICKUP RATIO			# OF ITEMS	SIGMA
	MAX	MIN	AVG.		
.173	3.3	.9	1.6	89	.4
.530	5.8	.8	1.8	100	.9
1.000	5.3	.9	1.8	104	.8
5.000	6.1	.5	2.0	79	1.1
10.000	7.5	.5	2.4	82	1.5

Figure 4-6

RATIO OF NORMALIZED DATA TO COMPUTED VALUE  
FOR THE DATA NORMALIZED IN FREQUENCY AND DRIVE CURRENT  
TO 1 MHZ AND 10.0 AMPS

WITH X=0.0

FREQ(MHZ)	PICKUP RATIO			# OF ITEMS	SIGMA
	MAX	MIN	AVG.		
.173	2.4	.5	1.3	184	.3
.530	5.4	.1	1.6	195	.9
1.000	4.1	.4	1.4	195	.5
5.000	4.2	.6	1.4	148	.4
10.000	3.7	.4	1.4	170	.5

WITH Z=0.0

.173	3.3	.8	1.7	160	.4
.530	7.1	.7	1.9	187	1.1
1.000	5.3	.9	1.7	189	.7
5.000	8.0	.4	2.0	142	1.1
10.000	13.0	.4	2.7	174	2.0

FOR ALL DATA

.173	3.3	.5	1.5	344	.4
.530	7.1	.1	1.8	382	1.0
1.000	5.3	.4	1.6	384	.6
5.000	8.0	.4	1.6	290	.9
10.000	13.0	.4	2.0	344	1.6

NOTE THAT SIGMA (S) IS COMPUTED FROM:

$$S^{**2} = (1/(N-1)) * (SUM((X-MEAN)**2))$$

WHERE: N=# OF ITEMS; X IS PICKUP; AND MEAN IS THE MEAN OF THE PICKUPS

Figure 4-6 (Continued)

F-C5490

WITH X=0.0 ; Z=1.5 AND DIRECTION= ALONG THE DRIFT

FREQ(MHZ)	PICKUP RATIO			# OF ITEMS	SIGMA
	MAX	MIN	AVG.		
.173	1.6	.7	1.2	19	.2
.530	3.8	.1	1.5	18	.8
1.000	2.7	.9	1.4	18	.4
5.000	1.8	.8	1.2	13	.3
10.000	2.0	.7	1.2	20	.4

WITH X=0.0 ; Z=1.5 AND DIRECTION= ACROSS THE DRIFT

FREQ(MHZ)	PICKUP RATIO			# OF ITEMS	SIGMA
	MAX	MIN	AVG.		
.173	1.5	.7	1.2	18	.2
.530	4.7	1.1	1.7	18	1.0
1.000	3.1	1.1	1.6	18	.6
5.000	2.3	.7	1.3	16	.4
10.000	1.7	.6	1.2	15	.3

WITH X=0.0 ; Z=2.0 AND DIRECTION= ALONG THE DRIFT

FREQ(MHZ)	PICKUP RATIO			# OF ITEMS	SIGMA
	MAX	MIN	AVG.		
.173	1.7	1.0	1.4	19	.2
.530	3.9	.9	1.6	18	.8
1.000	1.5	.9	1.3	18	.2
5.000	1.6	1.0	1.2	12	.2
10.000	2.7	.6	1.4	17	.6

WITH X=0.0 ; Z=2.0 AND DIRECTION= ACROSS THE DRIFT

FREQ(MHZ)	PICKUP RATIO			# OF ITEMS	SIGMA
	MAX	MIN	AVG.		
.173	1.9	.5	1.3	14	.4
.530	3.6	1.1	1.6	15	.8
1.000	3.6	.8	1.6	15	.7
5.000	1.6	.6	1.3	8	.4
10.000	2.4	.9	1.4	10	.5

WITH X=0.0 ; Z=2.5 AND DIRECTION= ALONG THE DRIFT

FREQ(MHZ)	PICKUP RATIO			# OF ITEMS	SIGMA
	MAX	MIN	AVG.		
.173	1.9	1.1	1.7	15	.2
.530	4.8	.7	1.7	18	1.1
1.000	1.6	1.0	1.3	18	.2
5.000	1.8	.7	1.3	12	.4
10.000	2.5	.4	1.5	15	.6

Figure 4-6 (Continued)

WITH X=0.0 ; Z=2.5 AND DIRECTION= ACROSS THE DRIFT

F-C5490

FREQ(MHZ)	PICKUP RATIO			# OF ITEMS	SIGMA
	MAX	MIN	AVG.		
.173	1.9	.7	1.3	11	.4
.530	3.4	.9	1.7	13	.8
1.000	4.1	1.0	1.8	11	.9
5.000	2.2	.9	1.5	7	.5
10.000	2.3	.6	1.5	6	.7

WITH X=0.0 ; Z=3.0 AND DIRECTION= ALONG THE DRIFT

FREQ(MHZ)	PICKUP RATIO			# OF ITEMS	SIGMA
	MAX	MIN	AVG.		
.173	2.4	1.4	1.8	8	.4
.530	5.4	1.1	1.8	17	1.2
1.000	1.7	1.0	1.3	18	.2
5.000	2.7	.6	1.6	12	.7
10.000	3.7	.7	2.2	12	.9

WITH X=0.0 ; Z=3.0 AND DIRECTION= ACROSS THE DRIFT

FREQ(MHZ)	PICKUP RATIO			# OF ITEMS	SIGMA
	MAX	MIN	AVG.		
.173	2.0	1.1	1.3	6	.4
.530	3.0	1.1	1.7	6	.7
1.000	2.5	.4	1.6	7	.8
5.000	4.2	.7	2.1	4	1.5
10.000	3.5	1.1	2.1	3	1.2

WITH X= .5 ; Z=0.0 AND DIRECTION= ALONG THE DRIFT

FREQ(MHZ)	PICKUP RATIO			# OF ITEMS	SIGMA
	MAX	MIN	AVG.		
.173	3.2	.8	1.8	17	.6
.530	7.1	1.0	2.1	18	1.5
1.000	2.5	1.0	1.6	18	.4
5.000	2.7	.9	1.7	16	.4
10.000	3.4	.8	2.0	20	.8

WITH X= .5 ; Z=0.0 AND DIRECTION= ACROSS THE DRIFT

FREQ(MHZ)	PICKUP RATIO			# OF ITEMS	SIGMA
	MAX	MIN	AVG.		
.173	2.4	.9	1.4	18	.4
.530	3.6	.8	1.6	18	.8
1.000	5.3	1.2	2.2	18	1.1
5.000	2.5	1.1	1.7	16	.4
10.000	4.0	.8	1.7	16	.9

Figure 4-6 (Continued)

F-C5490

WITH X=1.0 ; Z=0.0 AND DIRECTION= ALONG THE DRIFT

FREQ(MHZ)	PICKUP RATIO			# OF ITEMS	SIGMA
	MAX	MIN	AVG.		
.173	2.0	1.0	1.5	17	.3
.530	4.6	1.1	1.8	18	1.0
1.000	2.2	1.0	1.4	18	.3
5.000	1.8	.9	1.4	16	.3
10.000	2.2	.4	1.4	20	.5

WITH X=1.0 ; Z=0.0 AND DIRECTION= ACROSS THE DRIFT

FREQ(MHZ)	PICKUP RATIO			# OF ITEMS	SIGMA
	MAX	MIN	AVG.		
.173	2.4	1.1	1.5	18	.3
.530	4.1	1.1	1.6	18	.8
1.000	4.3	1.2	1.8	18	.8
5.000	1.9	.5	1.3	15	.4
10.000	2.1	.5	1.5	16	.4

WITH X=1.5 ; Z=0.0 AND DIRECTION= ALONG THE DRIFT

FREQ(MHZ)	PICKUP RATIO			# OF ITEMS	SIGMA
	MAX	MIN	AVG.		
.173	1.9	1.1	1.6	17	.2
.530	5.0	.7	1.8	18	1.1
1.000	2.8	1.1	1.5	18	.4
5.000	4.0	.4	1.7	13	.9
10.000	3.6	.8	2.0	19	.7

WITH X=1.5 ; Z=0.0 AND DIRECTION= ACROSS THE DRIFT

FREQ(MHZ)	PICKUP RATIO			# OF ITEMS	SIGMA
	MAX	MIN	AVG.		
.173	2.7	.9	1.5	18	.4
.530	4.1	1.1	1.6	18	.8
1.000	3.8	.9	1.6	18	.7
5.000	3.5	.7	1.8	14	.7
10.000	2.9	1.1	1.9	15	.6

WITH X=2.0 ; Z=0.0 AND DIRECTION= ALONG THE DRIFT

FREQ(MHZ)	PICKUP RATIO			# OF ITEMS	SIGMA
	MAX	MIN	AVG.		
.173	2.1	1.0	1.7	12	.3
.530	4.8	1.1	1.9	15	1.1
1.000	2.3	1.1	1.5	15	.3
5.000	3.5	1.1	2.2	8	.9
10.000	6.7	1.2	3.3	15	1.6



Figure 4-6 (Continued)

F-C5490

WITH X=2.0 ; Z=0.0 AND DIRECTION= ACROSS THE DRIFT

FREQ(MHZ)	PICKUP RATIO			# OF ITEMS	SIGMA
	MAX	MIN	AVG.		
.173	2.8	1.4	1.8	16	.5
.530	3.8	1.1	1.6	18	.8
1.000	4.1	.9	1.6	18	.7
5.000	2.8	.9	1.9	12	.7
10.000	4.3	1.3	2.6	14	.9

WITH X=2.5 ; Z=0.0 AND DIRECTION= ALONG THE DRIFT

FREQ(MHZ)	PICKUP RATIO			# OF ITEMS	SIGMA
	MAX	MIN	AVG.		
.173	2.7	1.8	2.0	6	.4
.530	6.1	1.1	2.3	13	1.6
1.000	2.4	1.3	1.8	13	.3
5.000	6.1	1.4	2.9	6	1.7
10.000	8.3	2.4	5.2	11	1.9

WITH X=2.5 ; Z=0.0 AND DIRECTION= ACROSS THE DRIFT

FREQ(MHZ)	PICKUP RATIO			# OF ITEMS	SIGMA
	MAX	MIN	AVG.		
.173	2.6	1.3	1.9	13	.4
.530	4.8	1.3	1.9	18	1.1
1.000	4.3	1.0	1.8	17	.7
5.000	3.5	1.0	2.2	11	.9
10.000	6.2	1.6	3.5	11	1.6

WITH X=3.0 ; Z=0.0 AND DIRECTION= ALONG THE DRIFT

FREQ(MHZ)	PICKUP RATIO			# OF ITEMS	SIGMA
	MAX	MIN	AVG.		
.173	1.9	1.9	1.9	2	
.530	6.9	1.4	2.7	5	2.4
1.000	2.5	1.4	1.8	3	.6
5.000	8.0	1.4	4.0	4	3.1
10.000	13.0	3.3	8.1	7	3.7

WITH X=3.0 ; Z=0.0 AND DIRECTION= ACROSS THE DRIFT

FREQ(MHZ)	PICKUP RATIO			# OF ITEMS	SIGMA
	MAX	MIN	AVG.		
.173	3.3	1.9	2.2	6	.6
.530	5.8	1.4	2.4	10	1.5
1.000	4.4	1.1	2.0	15	.8
5.000	6.1	.8	3.3	11	1.9
10.000	7.5	2.8	4.6	10	1.9

RATIO OF NORMALIZED DATA TO COMPUTED VALUE  
FOR THE DATA NORMALIZED IN FREQUENCY AND DRIVE CURRENT  
TO 1 MHZ AND 10.0 AMPS

WITH X=0.0 ; Z= .5 AND DIRECTION= ALONG THE DRIFT

FREQ(MHZ)	PICKUP RATIO			# OF ITEMS	SIGMA
	MAX	MIN	AVG.		
.173	1.7	.9	1.2	19	.2
.530	4.2	1.1	1.6	18	.8
1.000	1.7	.8	1.3	18	.3
5.000	1.9	1.2	1.4	16	.2
10.000	1.7	.6	1.3	20	.3

NOTE THAT SIGMA (S) IS COMPUTED FROM:

$$S^{**2} = (1/(N-1)) * (SUM((X-MEAN)**2))$$

WHERE: N=# OF ITEMS; X IS PICKUP; AND MEAN IS THE MEAN OF THE PICKUPS

WITH X=0.0 ; Z= .5 AND DIRECTION= ACROSS THE DRIFT

FREQ(MHZ)	PICKUP RATIO			# OF ITEMS	SIGMA
	MAX	MIN	AVG.		
.173	1.8	.7	1.2	18	.3
.530	4.4	1.0	1.7	18	.9
1.000	4.1	1.0	1.6	18	.7
5.000	1.7	1.3	1.5	16	.1
10.000	2.1	1.1	1.5	16	.3

WITH X=0.0 ; Z=1.0 AND DIRECTION= ALONG THE DRIFT

FREQ(MHZ)	PICKUP RATIO			# OF ITEMS	SIGMA
	MAX	MIN	AVG.		
.173	1.6	.9	1.2	19	.2
.530	3.6	1.0	1.6	18	.7
1.000	2.3	.5	1.3	18	.4
5.000	1.5	.6	1.2	16	.2
10.000	1.8	.6	1.2	20	.3

WITH X=0.0 ; Z=1.0 AND DIRECTION= ACROSS THE DRIFT

FREQ(MHZ)	PICKUP RATIO			# OF ITEMS	SIGMA
	MAX	MIN	AVG.		
.173	1.6	.7	1.2	18	.2
.530	4.8	1.1	1.7	18	.9
1.000	3.2	.7	1.5	18	.7
5.000	2.1	.9	1.3	16	.3
10.000	1.6	.9	1.2	16	.2

Figure 4-8

F-C5490

\*\*\*\*\* BAR GRAPH FOR VARIABLE: PKUP \*\*\*\*\*

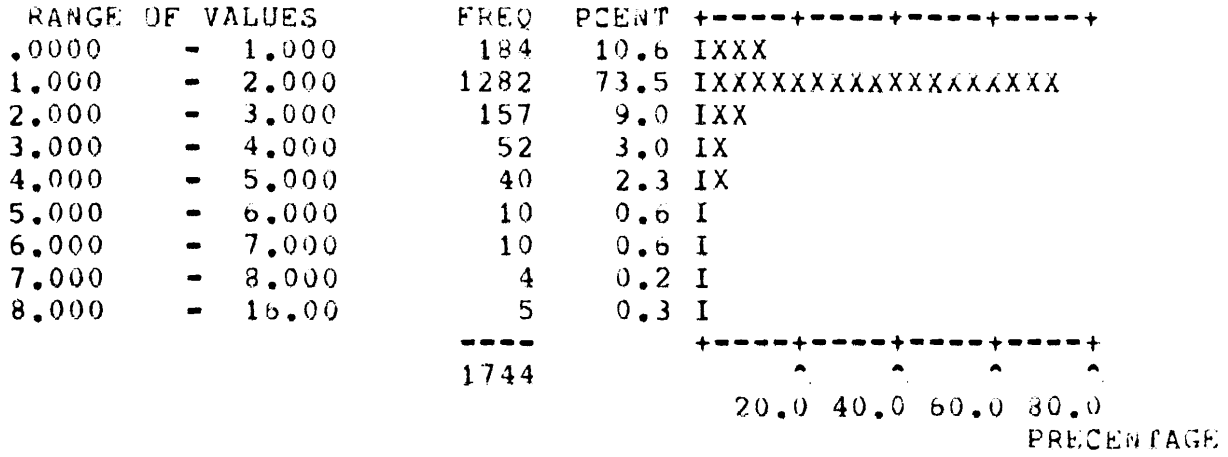

Figure 4-9

F-C5490

\*\*\*\*\* BAR GRAPH FOR VARIABLE: PKUP \*\*\*\*\*

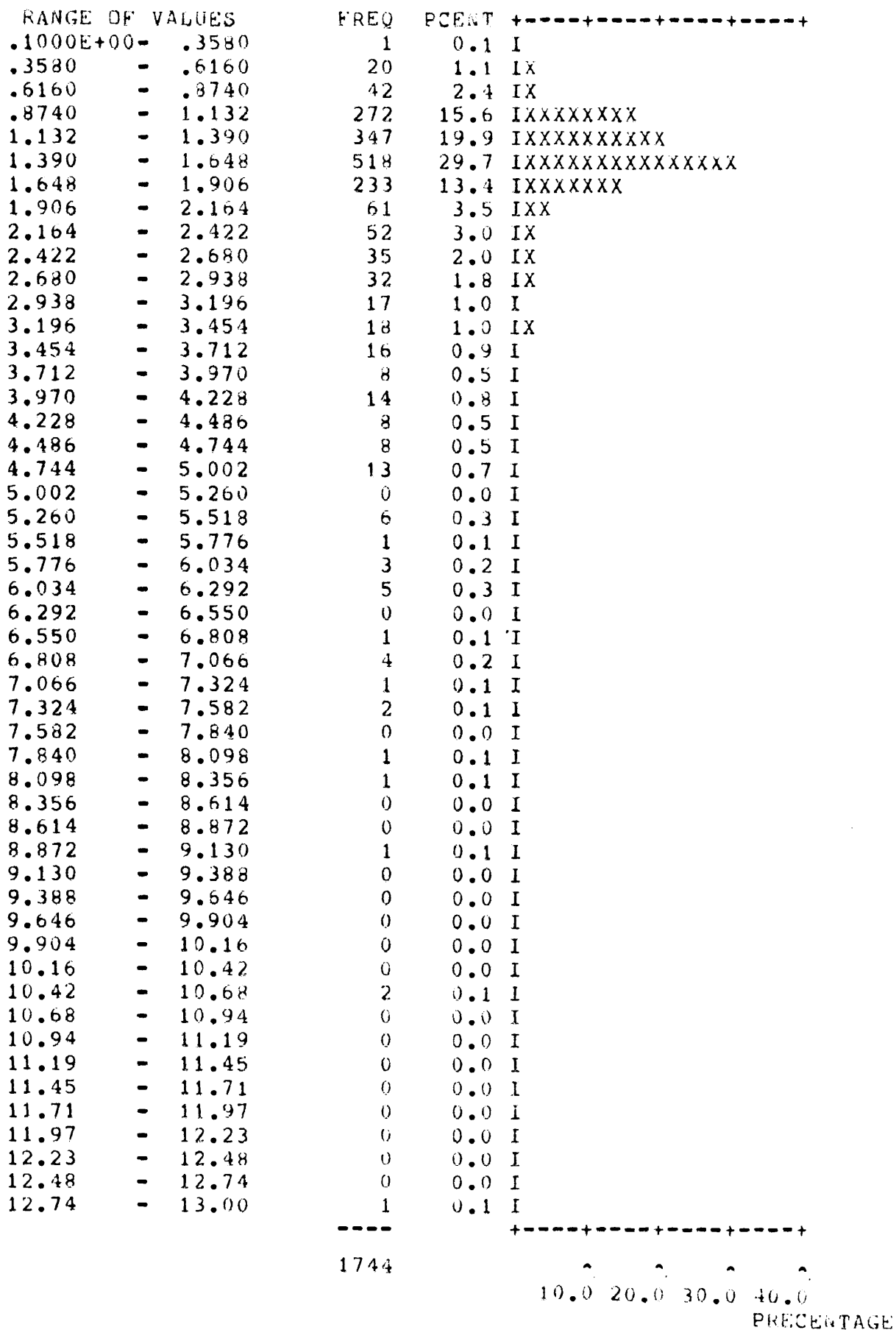

Figure 4-10 is the output of a commonly available statistics program (STP) that evaluated the basic statistics for the 1744 values of the measured to collected ratios. Figure 4-11 is an evaluation of the same data by the program that prepared the previously presented breakdowns. We present it here to show the agreement.

## 4.2 TRANSMISSION LINE RESULTS

We have processed the transmission line data in much the same manner as the loop data. In order to compare data at different mines the nearby frequencies are first grouped, e.g. 0.175, 0.74, 0.72 MHz, all go to 0.170 MHz, then all pickup data is normalized to a line current of 10 amperes. The data are all also normalized to a pickup for 1.0 MHz. The resulting data is plotted in Appendix G. Note that plots are presented for both  $Z = 0.5$  and  $Z = 1.0$  meters. This allows a comparison of the spread in the data for both mine location and  $Z$  distance.

We next computed the free space pickup from a 10 amp., 1 MHz current. This computation was performed by a specialized computer program. The results are given in Figure 4-12. The computer program only computes the magnitude and direction of the H field. Pick up for the 10 cm diameter search loop was computed from:

$$\text{Pickup (volts)} = A \omega \mu / H$$

where  $A$  = area of the pickup coil (radius 0.05 m)

$\omega = 2 \pi \text{ frequency} = 2 \pi \times 10^6$  for  $f = 10^6$

$\mu = 4 \pi \times 10^{-7}$  h/m

$/H/$  = magnitude of the H field linking the search coil

Appendix G gives the computer program output.

Using the calculated pickup and the current normalized data we can compare the measured results to the calculated free space values. The comparison is given for each measurement in Appendix I. Figure 4-13 breaks down the data by location and measurement point. Figure 4-14 gives the basic

Figure 4-10

## NORMALIZED PICKUP FOR ALL MINES

THERE ARE 1 VARIABLES AND 1744 OBSERVATIONS

VAR. PKUP	MEANS 1.696101	STD.DEV. 1.010665	VARIANCE 1.021444		
VAR. PKUP	MEDIAN 1.400000	MODE 1.400000	MAXIMUM 13.00000	MINIMUM 0.100000E+00	
VAR. PKUP	STD ERR OF MEAN 0.2420104E-01	SKEWNESS 3.968134	COEF. OF VAR. 59.58756		

Figure 4-11

RATIO OF NORMALIZED LOOPDATA TO COMPUTED VALUE  
FOR THE DATA NORMALIZED IN FREQUENCY AND DRIVE CURRENT  
TO 1 MHZ AND 10.0 AMPS

FOR ALL LOOP DATA

PICKUP RATIO			# OF ITEMS	SIGMA
MAX	MIN	AVG.		
13.0	.1	1.7	1744	1.0107

Figure 4-12

Free Space H Field and Pickup From Transmission Line  
Wire Configuration -- 10 Amps at 1 MHz

---

Z Meters	Y Meters	H Amps/Meters	Pickup (mV)
0.5	0.5	3.21	199
0.5	1.0	1.3	80.6
0.5	1.5	0.664	41.176
1.0	0.5	1.3	80.6
1.0	1.0	0.826	51.22
1.0	1.5	0.52	32.2

---

Figure 4-13

FOR TRANSMISSION LINE DATA  
 ALL DATA NORMALIZED TO 10 AMPS AND 1 MHz

F-C5490

RATIO OF MEASURED/CALCULATED FOR DATA

LOCATION	MIN	MAX	AVG	# ITEMS
1	.591	2.481	1.302	14
2	.764	2.256	1.218	16
3	.914	2.377	1.333	18
4	.680	1.997	1.093	16
5	.731	1.997	1.084	16
6	.607	1.861	.991	16
7	.827	4.726	2.354	8
8	.993	5.104	2.123	10
9	.837	2.995	1.549	14

RATIO OF MEASURED/CALCULATED FOR ALL DATA

MIN	MAX	AVG	# ITEMS
.591	5.104	1.361	128

RATIO OF MEASURED/CALCULATED FOR DATA  
 FOR ALL Y=.5 DATA

MIN	MAX	AVG	# ITEMS
.591	5.104	1.725	52

RATIO OF MEASURED/CALCULATED FOR DATA  
 FOR ALL Y=1.0 DATA

MIN	MAX	AVG	# ITEMS
.620	2.231	1.167	46

RATIO OF MEASURED/CALCULATED FOR DATA  
 FOR ALL Y=1.5 DATA

MIN	MAX	AVG	# ITEMS
.607	1.581	1.026	30

RATIO OF MEASURED/CALCULATED FOR DATA  
 FOR ALL Z=0.5 DATA

MIN	MAX	AVG	# ITEMS
.591	1.914	.980	64

RATIO OF MEASURED/CALCULATED FOR DATA  
 FOR ALL Z=1.0 DATA

MIN	MAX	AVG	# ITEMS
.731	5.104	1.741	64



Figure 4-14

F-C5490

TRANSMISSION LINE - MEASURED/CALCULATED

THERE ARE 1 VARIABLES AND 128 OBSERVATIONS

VAR.	MEANS	STD.DEV.	VARIANCE	
PKUP	1.360641	0.7601704	0.5778590	
VAR.	MEDIAN	MODE	MAXIMUM	MINIMUM
PKUP	1.116000	0.6200000	* 5.104000	0.5910000
* MORE THAN 1 MODE EXISTS - ONLY THE FIRST IS SHOWN				
VAR.	STD ERR OF MEAN	SKEWNESS	COEF. OF VAR.	
PKUP	0.6719620E-01	2.552539	55.86856	

Transmission Line Data Basic Statistics

statistics for all the transmission line measured/calculated ratios and Figures 4-15 and 4-16 are bar graphs of the distribution.

Note that there are only 4 of the 128 ratios more than 3 (about 3.2%) and of these, 2 occur at location 7 and 2 at location 8. Study of the notebook entries -- and Appendix C -- shows that all three values greater than 4 are associated with a measurement at 170 or 500 KHz at a point 0.5 meters from the plane of the rectangular loop and 1 meter from the floor. This measurement point is the one nearest to the driven wires of the loop. The field varies more rapidly at this point than at any other measurement point. Errors in pickup measurement due to pickup loop location uncertainty would be expected to be maximum at this point.

Figure 4-15

F-C5490

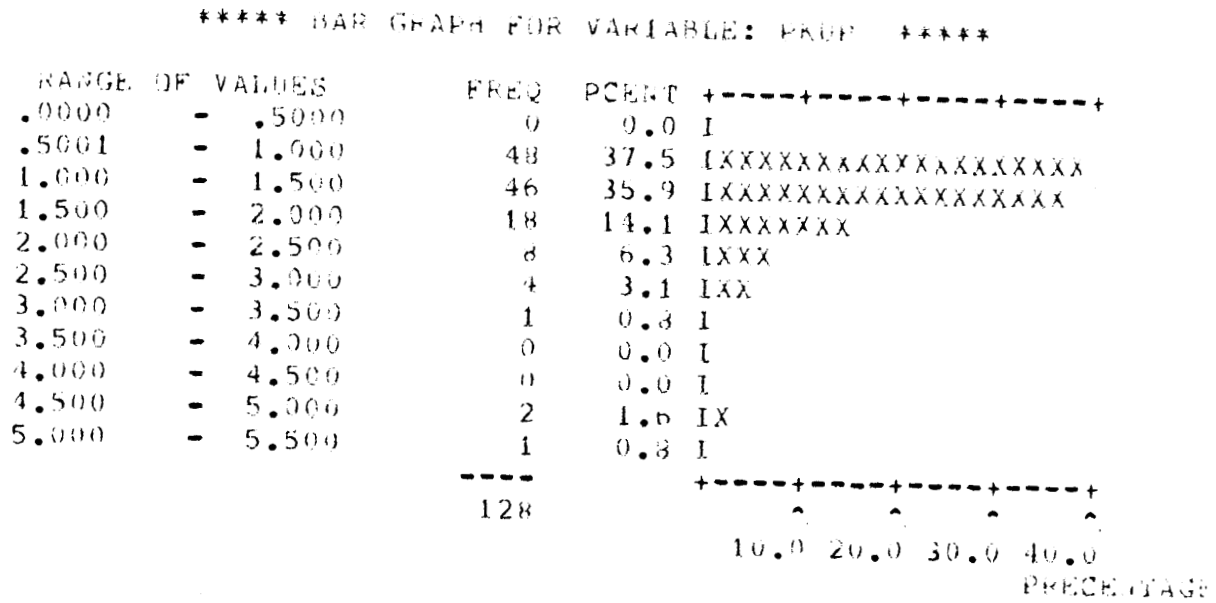

Bargraph of Measured/Calculated  
Ratio Distribution—Course Division

Figure 4-16

EMISSION LINE - MEASURED/CALCULATED

\*\*\*\*\* BARGRAPH FOR VARIABLE: FREQ \*\*\*\*\*

F-C5490

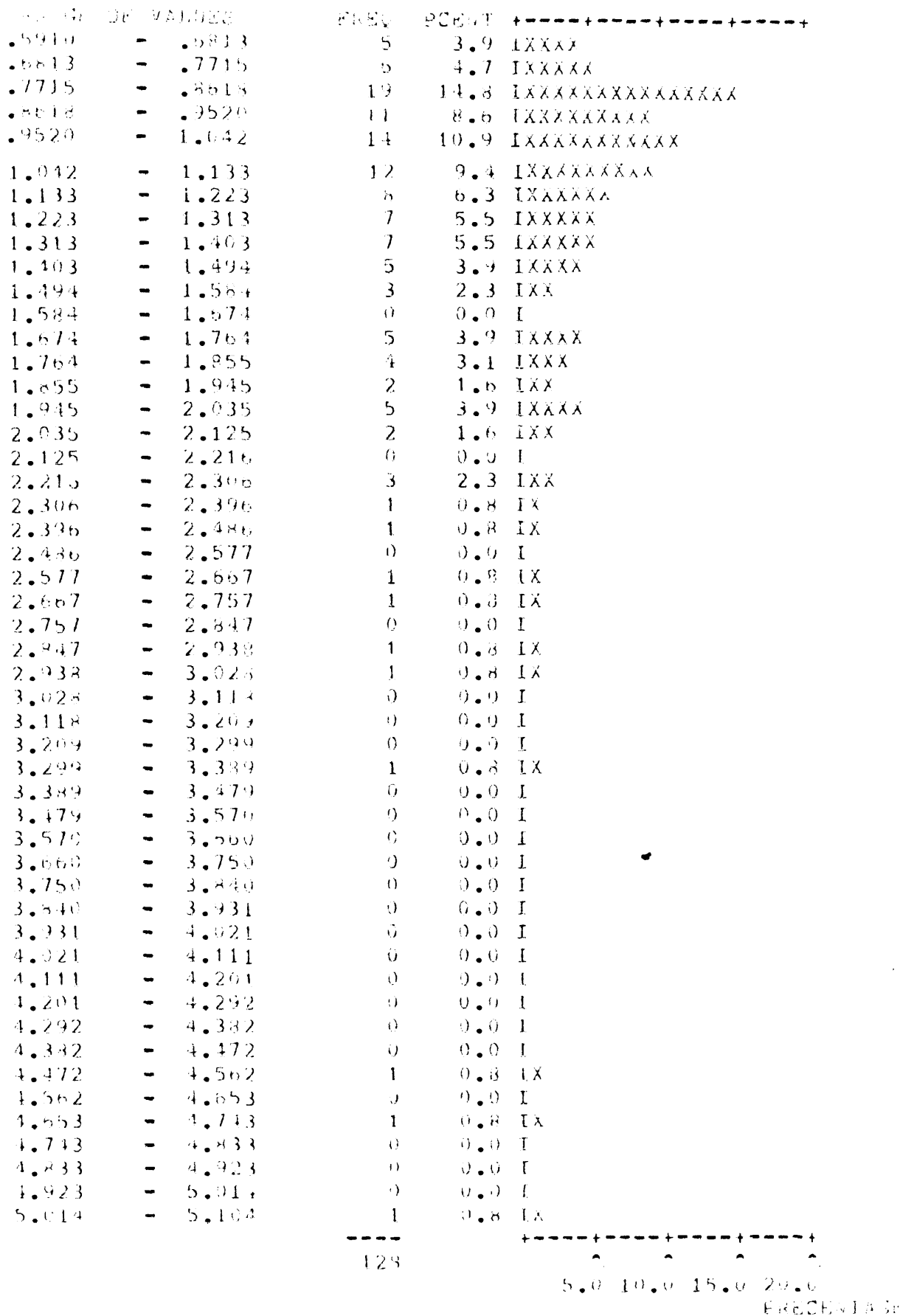

\*\* Bargraph of Measured/Calculation Ratio Distribution - Fine Division \*\*

## 5. CONCLUSIONS FROM MEASUREMENTS

Study of our data indicates that, for frequencies of 10 MHz and below, an adequate worst case approximation for the magnitude of the magnetic field, for use in blasting safe distances, can be computed from the free space predictions of the magnetic field if we use a multiplying factor of 5.

Only one of our transmission line measurements showed ratios as high as 5 and of the 1.7% of our loop measurements that were greater than 5, most seem to be associated with measurements taken very close to conductors or in -- or close to -- our noise level for the measurement. Further those ratios greater than 5 that were not associated with measurement near conductors or close to the noise level are isolated, i.e. the neighboring values are not greater than five. This indicates a "hot spot" of small extent or errors in the measurements. For use in the calculation of blasting safe distances, "hot spots" of very localized extent will not contribute unduly to the overall pickup and they can be safely ignored.

## 6.0 SAFE DISTANCES FROM SOURCES

## 6.1 CRITICAL VALUES OF THE FIELD

In order to evaluate safe distances for blasting wire from transmission line and loop sources we assume -- as a worst case estimate -- that the shorted loop of blasting wiring is arranged normal to the B field produced by the source and that it is formed as a circle of area A square meters. This assures maximum area for a given lead length. Further, we assume that the  $/B/$  linking the loop is the maximum  $/B/$  anywhere in the loop. Thus, if the edge of the loop is at a given maximum of the source field and the field is less at other portions of the loop, we will use the maximum value of  $/B/$  everywhere in the loop. This is a worst case assumption. We further assume that the blasting wiring loop is loaded with only one cap and that its resistance is  $R_{dc}$  and  $R_{dc}$  equals 1 ohm. This, too, is a worst case assumption in that more resistance lessens power pickup and the nominal resistance of American made caps is 1.2 ohms or greater (Reference 7, p. 4-3).

The maximum open circuit voltage included in the blasting wiring is then

$$V_b = A \frac{2}{2\epsilon} \frac{/B_m/}{\epsilon} \cos \omega t \quad (6-1)$$

where  $\omega = 2\pi f_{\text{MHz}} \times 10^6$   
 $f_{\text{MHz}}$  = frequency in megahertz  
 $/B_m/$  = the maximum B field magnitude linking the loop. Note that we will use this notation throughout this report, i.e.  $/A/$  is read as "magnitude of the vector (or phasor) A."  
 A = area of the blasting cap  
 $V_b$  = open circuit voltage and

In terms of the H field ( $B = \mu H$ )

$$|V_b| = A \omega \mu |H| \quad (6-2)$$

where  $\ell = 4 \pi \times 10^{-7}$  henrys/meter and  
 $|H|$  = maximum  $|H|$  linking the loop - amps/meter

The total current  $|I_B|$  that will flow in the blasting wiring loop is

$$|I_B| = \frac{|V_b|}{Z_b} = \frac{A \omega \mu |H|}{|Z_b|} \quad (6-3)$$

where  $Z_b$  is the total impedance of the blasting wiring loop. This impedance includes  $R_{dc}$  -- the blasting cap resistance -- any reactance of the cap, any internal drop of the wire forming the loop and the external inductance for the loop. The external inductance term is of considerable importance for our application. It represents the reduction in current flow due to the reduction of the linking B field by the field produced by the current in the loop. Reference 8, Chapter 5, gives an excellent outline of these points.

$$\text{Thus, } Z_b = R_{dc} + Z_i + j\omega L_o + jX_{cap} \quad (6-4)$$

where  $Z_b$  is the internal impedance of the blasting wire forming the loop,  
 $L_o$  is the external inductance of the loop and,  
 $X_{cap}$  is the reactance of the cap.

We will assume that the blasting wire that forms the pickup loop is 20 gauge (B & W) copper wire. Caps are usually supplied in 22 gauge for short leads (30 feet or less) and 20 gauge for longer wires. 20 gauge wire has a diameter of 31.96 mils (0.8118 millimeters) and a dc resistance of

10.15 ohms/1000 feet. Figure 6-1 is from reference 8, p. 297. It shows the variation of the internal impedance terms for round wires in terms of  $R_0$  (the dc resistance),  $r_0$  (the radius of the wire) and  $\delta$  (the skin depth). Figure 6-2 gives the same data in a more accessible way for the internal resistance term.

Using these figures, we compute that

$$Z_i = \left\{ 0.008 + 0.102(1+j)\sqrt{f_{MHz}} \right\} \text{ ohms/meter} \quad (6-5)$$

For a circle of this wire of area A square meters,

$$Z_i = \sqrt{A\pi} \left\{ 0.016 + 0.204(1+j)\sqrt{f_{MHz}} \right\} \text{ ohms} \quad (6-6)$$

The  $X_{cap}$  term is of the form  $\omega L_c$ , where  $L_c$  is the external inductance of the small rectangular loop (approximately 1mm x 1 cm) formed where the cap leads enter the base of the cap through the cap plug. The external inductance for a circular loop of the same area can be evaluated using (see reference 8, page 311)

$$L = r_0 \mu \left[ \ln \left( \frac{8r_0}{a_c} \right) - 2 \right] \quad (6-7)$$

where  $r_0$  is the radius of the loop,  $\mu = 4\pi \times 10^{-7}$  and  $a_c$  is the radius of the wire (.81 mm). Since the area of our loop is  $(10^{-3} \times 10^{-2}) = 10^{-5} \text{ m}^2$ , and  $r = \sqrt{A/\pi}$  for a circle, we compute

$$L_c = 0.00196 \text{ microhenrys}$$



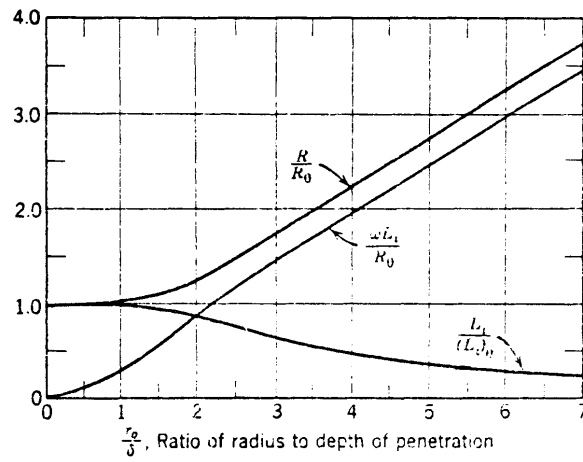
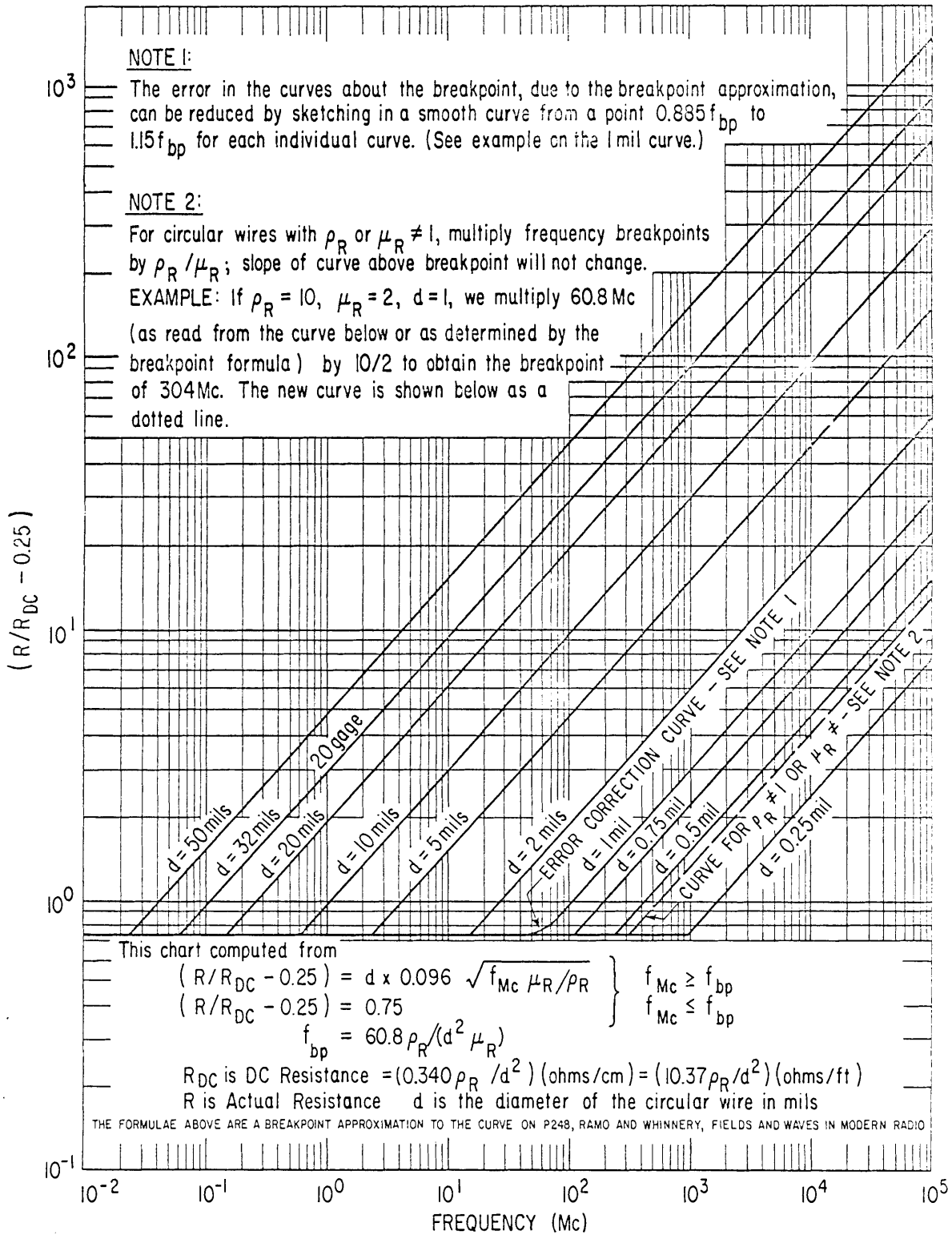

Figure 6-1

Solid wire skin effect quantities compared with d-c values.

Figure 6-2



$(R/R_{DC} - 0.25)$  vs. Frequency for a Circular Wire  $R = R = 1$

The  $L_0$  term of (6-4) is evaluated in the same way from equation 6-7; we obtain

$$L_0 = \sqrt{\frac{A}{\pi}} \cdot 4\pi \cdot 10^{-7} \left[ \ln \left( \frac{e \cdot \sqrt{A}}{c \cdot 3118 \cdot 10^3} \right) - \frac{2}{\pi} \right] \text{microhenrys} \quad (6-8)$$

We can now write equation (6-4) as

$$Z_b = R_{dc} + \sqrt{A\pi} \left\{ 0.016 + 0.204(1+j)\sqrt{f_{att}} \right\} + j\omega \sqrt{\frac{A}{\pi}} \cdot 4\pi \cdot 10^{-7} \left[ \ln \left( \frac{e \cdot \sqrt{A}}{c \cdot 3118 \cdot 10^3} \right) - \frac{2}{\pi} \right] + j\omega \cdot 1.96 \cdot 10^{-9} \quad (6-9)$$

At frequencies as high as 10 MHz and areas as large as 10 square meters, all of the terms can have magnitudes comparable to  $R_{dc} = 1$  so we will retain them all in our calculations.

The no-fire power level (0.1% probability) with 95% confidence) for American made caps is 0.04 watts. For a 1 ohm cap this gives a no-fire current level of 0.2 amperes. If we substitute this value for current in equation 6-3 we form an expression for  $|H|$  that will just produce the no-fire current in the cap. Thus

$$0.2 = \frac{A \mu \omega |H|}{|Z_b|} \quad (6-10)$$

or

$$|H_c| = \frac{0.2 |Z_b|}{A \mu w} \quad (6-11)$$

where here we have written  $|H_c|$  to call attention to the fact that this is the critical value of  $|H|$  and we have indicated that the magnitude of the impedance  $Z_b$  is to be used. Note that  $Z_b$  is given completely in terms of frequency and area (A) of the blasting cap wiring. We have used a computer program to evaluate equation 6-11. Figure 6-3 lists the values of  $|H_c|$  for frequencies up to 10 MHz and areas up to 10 square meters. Figure 6-4 shows  $|H_c|$  for a finer gradation of frequencies for the 0.1 to 1 MHz range.

If we can now calculate the free space values of  $|H|$  due to various sources; we can determine safe distances for the blasting wiring configurations.

## 6.2 FREE SPACE VALUES OF THE FIELD FROM VARIOUS SOURCES

Our main concern is with small loop antennas such as those used in "back pack" applications and bandolier configurations. Also we are interested in the typical "trolley wire" communication systems.

For the trolley wire configuration, we consider the geometry of Figure 6-5. Figures 6-6 through 6-10 give, for a current of 1 ampere, the magnitude of the H field along various lines indicated in Figure 6-5. Figure 6-11 through 6-13 give the same sort of data for the lines indicated in Figure 6-14. Study of these plots shows the magnitude of the H field ( $|H|$ ) around the 2 meter separation transmission line varies from about 0.318 half way between the driven lines, to about 0.15 at 1 meter away along the y axis. Figure 6-15 shows some of the values. For the 0.5 meter radius loop the  $|H|$

Figure 6-3

## Frequencies from 0.01 to 10 MHz

VALUES OF HAZARD CRITICAL H FIELD FOR VARIOUS CONDITIONS  
 RDC=1 OHM, CRITICAL HAZARD CURRENT= 0.2 AMPS

FOR PICKUP AREA= 0.000100 SQ. METERS

FREQUENCY(HZ)	HC (AMPS/METER)	X/RDC	MICROHENRYS
0.010000	25346.717000	0.001693	0.026937
0.031623	8017.672500	0.004852	0.024419
0.100000	2536.912600	0.014453	0.023002
0.316228	803.648980	0.044122	0.022206
1.000000	256.638170	0.136710	0.021758
3.162278	87.602976	0.427312	0.021506
10.000000	42.578767	1.342380	0.021365

FOR PICKUP AREA= 0.000316 SQ. METERS

FREQUENCY(HZ)	HC (AMPS/METER)	X/RDC	MICROHENRYS
0.010000	8019.391600	0.003370	0.053634
0.031623	2537.328200	0.009767	0.049156
0.100000	803.391260	0.029303	0.046637
0.316228	255.363250	0.089850	0.045221
1.000000	83.698559	0.279125	0.044424
3.162278	33.865993	0.873773	0.043976
10.000000	23.476313	2.747287	0.043724

FOR PICKUP AREA= 0.001000 SQ. METERS

FREQUENCY(HZ)	HC (AMPS/METER)	X/RDC	MICROHENRYS
0.010000	2538.258600	0.006708	0.106757
0.031623	803.516550	0.019629	0.098793
0.100000	254.888810	0.059259	0.094314
0.316228	82.000418	0.182390	0.091796
1.000000	29.401626	0.567869	0.090379
3.162278	16.437565	1.779934	0.089583
10.000000	14.427429	5.600504	0.089135

Figure 6-3 (Con't.)

## Frequencies from 0.01 to 10 MHz

VALUES OF HAZARD CRITICAL H FIELD FOR VARIOUS CONDITIONS  
RDC=1 OHM, CRITICAL HAZARD CURRENT= 0.2 AMPS

FOR PICKUP AREA= 0.003162 SQ. METERS

FREQUENCY(HZ)	HC(AMPS/METER)	X/RDC	MICROHENRYS
0.010000	803.992080	0.013274	0.211270
0.031623	254.816410	0.039163	0.197106
0.100000	81.303556	0.118841	0.189142
0.316228	27.291609	0.366910	0.184663
1.000000	12.290029	1.144466	0.182144
3.162278	9.458130	3.590916	0.160728
10.000000	9.095986	11.305431	0.179932

FOR PICKUP AREA= 0.010000 SQ. METERS

FREQUENCY(HZ)	HC(AMPS/METER)	X/RDC	MICROHENRYS
0.010000	255.023160	0.026074	0.414983
0.031623	81.081456	0.077449	0.389797
0.100000	26.378213	0.236018	0.375634
0.316228	10.070351	0.730526	0.367669
1.000000	6.351298	2.281992	0.363191
3.162278	5.803572	7.166248	0.360572
10.000000	5.724734	22.572677	0.359256

FOR PICKUP AREA= 0.031623 SQ. METERS

FREQUENCY(HZ)	HC(AMPS/METER)	X/RDC	MICROHENRYS
0.010000	81.122809	0.050531	0.809006
0.031623	26.033408	0.151844	0.764218
0.100000	9.016372	0.464347	0.739032
0.316228	4.501701	1.440254	0.724869
1.000000	3.708405	4.504440	0.716904
3.162278	3.596779	14.155299	0.712426
10.000000	3.574220	44.604736	0.709907

FOR PICKUP AREA= 0.100000 SQ. METERS

FREQUENCY(HZ)	HC(AMPS/METER)	X/RDC	MICROHENRYS
0.010000	25.967046	0.098405	1.566173
0.031623	8.577597	0.295361	1.486528
0.100000	3.503371	0.905871	1.441740
0.316228	2.412869	2.814573	1.416554
1.000000	2.250639	8.811472	1.402391
3.162278	2.221423	27.706073	1.394426
10.000000	2.212444	87.332887	1.389947

Figure 6-3 (Con't.)

## Frequencies from 0.01 to 10 MHz

VALUES OF HAZARD CRITICAL H FIELD FOR VARIOUS CONDITIONS  
 RDC=1 OHM, CRITICAL HAZARD CURRENT= 0.2 AMPS

FOR PICKUP AREA= 0.316228 SQ. METERS

FREQUENCY (MHZ)	HC (AMPS/METER)	X/RDC	MICROHENRYS
0.010000	8.438153	0.189317	3.013072
0.031623	3.031642	0.570531	2.871440
0.100000	1.650155	1.754135	2.791795
0.316228	1.411882	5.458072	2.747007
1.000000	1.373349	17.101691	2.721821
3.162278	1.363191	53.798885	2.707656
10.000000	1.358800	169.626590	2.699693

FOR PICKUP AREA= 1.000000 SQ. METERS

FREQUENCY (MHZ)	HC (AMPS/METER)	X/RDC	MICROHENRYS
0.010000	2.848272	0.362205	5.764681
0.031623	1.239297	1.095351	5.512820
0.100000	0.902526	3.374814	5.371188
0.316228	0.817935	10.513852	5.291543
1.000000	0.835790	32.966307	5.246755
3.162278	0.831147	103.748190	5.221559
10.000000	0.828803	327.190690	5.207406

FOR PICKUP AREA= 3.162278 SQ. METERS

FREQUENCY (MHZ)	HC (AMPS/METER)	X/RDC	MICROHENRYS
0.010000	1.049966	0.689607	10.975444
0.031623	0.606452	2.091739	10.527565
0.100000	0.526829	6.456410	10.275704
0.316228	0.511293	20.135550	10.134072
1.000000	0.506214	63.173774	10.054427
3.162278	0.503808	198.883120	10.009639
10.000000	0.502516	627.341150	9.984453

FOR PICKUP AREA= 10.000000 SQ. METERS

FREQUENCY (MHZ)	HC (AMPS/METER)	X/RDC	MICROHENRYS
0.010000	0.450191	1.307308	20.806476
0.031623	0.334888	3.975824	20.010023
0.100000	0.313564	12.291247	19.562144
0.316228	0.307646	38.367910	19.310283
1.000000	0.305131	120.440090	19.168651
3.162278	0.303822	379.282510	19.089005
10.000000	0.303101	1196.582500	19.044217

Figure 6-4  
Frequencies from 0.1 to 1 MHz

VALUES OF HAZARD CRITICAL H FIELD FOR VARIOUS CONDITIONS  
FDC=1 DB, CRITICAL HAZARD CURRENT= 0.2 AMPS

FOR PICKUP AREA= 0.000100 SQ. METERS

FREQUENCY(HZ)	HC (AMPS/METER)	X/RDC	MICROHENRYS
0.100000	2536.912700	0.014453	0.023002
0.200000	1269.427900	0.028236	0.022469
0.300000	846.995750	0.041909	0.022233
0.400000	635.859130	0.055525	0.022093
0.500000	509.250480	0.069104	0.021997
0.600000	424.909770	0.082658	0.021926
0.700000	364.724080	0.096191	0.021871
0.800000	319.636220	0.109710	0.021826
0.900000	284.614070	0.123215	0.021789
1.000000	256.638180	0.136710	0.021758

FOR PICKUP AREA= 0.000316 SQ. METERS

FREQUENCY(HZ)	HC (AMPS/METER)	X/RDC	MICROHENRYS
0.100000	803.391270	0.029303	0.046637
0.200000	402.518840	0.057415	0.045689
0.300000	269.046640	0.085330	0.045259
0.400000	202.441200	0.113145	0.045019
0.500000	162.586730	0.140894	0.044848
0.600000	136.108340	0.168598	0.044722
0.700000	117.274720	0.196266	0.044624
0.800000	103.217460	0.223967	0.044545
0.900000	92.344069	0.251526	0.044480
1.000000	83.698562	0.279125	0.044424

FOR PICKUP AREA= 0.001000 SQ. METERS

FREQUENCY(HZ)	HC (AMPS/METER)	X/RDC	MICROHENRYS
0.100000	254.688820	0.059259	0.094314
0.200000	128.262950	0.116400	0.092629
0.300000	86.287155	0.173193	0.091882
0.400000	65.478232	0.229865	0.091437
0.500000	53.133698	0.286302	0.091133
0.600000	45.017464	0.342718	0.090909
0.700000	39.313161	0.399071	0.090734
0.800000	35.112133	0.455375	0.090594
0.900000	31.909330	0.511639	0.090478
1.000000	29.401627	0.567869	0.090379



Figure 6-4

## Frequencies from 0.1 to 1 MHz

VALUES OF HAZARD CRITICAL B FIELD FOR VARIOUS CONDITIONS  
RDC=1 OHM, CRITICAL HAZARD CURRENT= 0.2 AMPS

FOR PICKUP AREA= 0.003162 SQ. METERS

FREQUENCY (MHZ)	HC (AMPS/METER)	X/RDC	MICROHENRYS
0.100000	61.303558	0.118841	0.189142
0.200000	41.548839	0.233916	0.186145
0.300000	28.595594	0.348371	0.184817
0.400000	22.326551	0.462505	0.184025
0.500000	18.713458	0.576434	0.183485
0.600000	16.412630	0.690218	0.183088
0.700000	14.848695	0.803891	0.182776
0.800000	13.734988	0.917477	0.182526
0.900000	12.913379	1.030992	0.182319
1.000000	12.290029	1.144446	0.182144

FOR PICKUP AREA= 0.010000 SQ. METERS

FREQUENCY (MHZ)	HC (AMPS/METER)	X/RDC	MICROHENRYS
0.100000	26.378213	0.236018	0.375634
0.200000	14.187886	0.465337	0.370304
0.300000	10.433078	0.693555	0.367942
0.400000	8.730432	0.921262	0.366535
0.500000	7.810013	1.148484	0.365574
0.600000	7.256774	1.375508	0.364865
0.700000	6.898905	1.602335	0.364314
0.800000	6.654383	1.829008	0.363870
0.900000	6.480607	2.055553	0.363502
1.000000	6.351298	2.281992	0.363191

FOR PICKUP AREA= 0.031623 SQ. METERS

FREQUENCY (MHZ)	HC (AMPS/METER)	X/RDC	MICROHENRYS
0.100000	9.016372	0.464347	0.739032
0.200000	5.534014	0.916783	0.729554
0.300000	4.587165	1.367260	0.725355
0.400000	4.197691	1.816722	0.722851
0.500000	4.000662	2.265536	0.721143
0.600000	3.887174	2.713890	0.719882
0.700000	3.815666	3.161895	0.718902
0.800000	3.767542	3.609623	0.718112
0.900000	3.733484	4.057126	0.717458
1.000000	3.708405	4.504439	0.716904

FOR PICKUP AREA= 0.100000 SQ. METERS

FREQUENCY (MHZ)	HC (AMPS/METER)	X/RDC	MICROHENRYS
0.100000	3.503371	0.905871	1.441746
0.200000	2.635429	1.799561	1.424865
0.300000	2.430577	2.671767	1.417417
0.400000	2.356743	3.551168	1.412966
0.500000	2.310896	4.429417	1.409928

0.600000	2.267816	5.306847	1.407686
0.700000	2.273053	6.183656	1.405943
0.800000	2.262915	7.059975	1.404539
0.900000	2.255576	7.935892	1.403375
1.000000	2.250039	8.811472	1.402391

Figure 6-4 (Con't.)  
Frequencies from 0.1 to 1 MHz

VALUES OF HAZARD CRITICAL H FIELD FOR VARIOUS CONDITIONS  
RDC=1 OHM, CRITICAL HAZARD CURRENT= 0.2 AMPS

FOR PICKUP AREA= 0.316228 SQ. METERS

FREQUENCY (MHZ)	HC (AMPS/METER)	X/RDC	MICROHENRYS
0.100000	1.650155	1.754135	2.791795
0.200000	1.458986	3.470604	2.761822
0.300000	1.415690	5.180877	2.748543
0.400000	1.398250	6.887942	2.740627
0.500000	1.389099	8.592957	2.735225
0.600000	1.383510	10.296515	2.731238
0.700000	1.379743	11.998971	2.728139
0.800000	1.377027	13.700553	2.725641
0.900000	1.374969	15.401421	2.723571
1.000000	1.373349	17.101691	2.721821

FOR PICKUP AREA= 1.000000 SQ. METERS

FREQUENCY (MHZ)	HC (AMPS/METER)	X/RDC	MICROHENRYS
0.100000	0.902526	3.374814	5.371188
0.200000	0.859685	6.682649	5.317887
0.300000	0.848950	9.979463	5.294274
0.400000	0.844132	13.270574	5.280198
0.500000	0.841360	16.558039	5.270592
0.600000	0.839532	19.842915	5.263501
0.700000	0.838220	23.125828	5.257990
0.800000	0.837224	26.407186	5.253548
0.900000	0.836434	29.687279	5.249868
1.000000	0.835790	32.966306	5.246755

FOR PICKUP AREA= 3.162278 SQ. METERS

FREQUENCY (MHZ)	HC (AMPS/METER)	X/RDC	MICROHENRYS
0.100000	0.526829	6.456410	10.275704
0.200000	0.515193	12.793711	10.180920
0.300000	0.511657	19.111415	10.138929
0.400000	0.509861	25.418976	10.113698
0.500000	0.508737	31.720054	10.096815
0.600000	0.507951	38.016528	10.084206
0.700000	0.507353	44.309512	10.074405
0.800000	0.506901	50.599733	10.066506
0.900000	0.506526	56.887699	10.059962
1.000000	0.506214	63.173772	10.054427

FOR PICKUP AREA= 10.000000 SQ. METERS

FREQUENCY (MHZ)	HC (AMPS/METER)	X/RDC	MICROHENRYS
0.100000	0.313504	12.291247	19.562144
0.200000	0.309324	24.370685	19.393591
0.300000	0.307812	36.415276	19.318929
0.400000	0.306977	48.441827	19.274407
0.500000	0.306429	60.456851	19.244030

Figure 6-4 (Con't.)

F-C5490

0.600000	0.306035	72.463687	19.221606
0.700000	0.305734	84.464318	19.204179
0.800000	0.305494	96.469037	19.190131
0.900000	0.305297	108.451740	19.178494
1.000000	0.305131	120.440080	19.168651

Figure 6-5

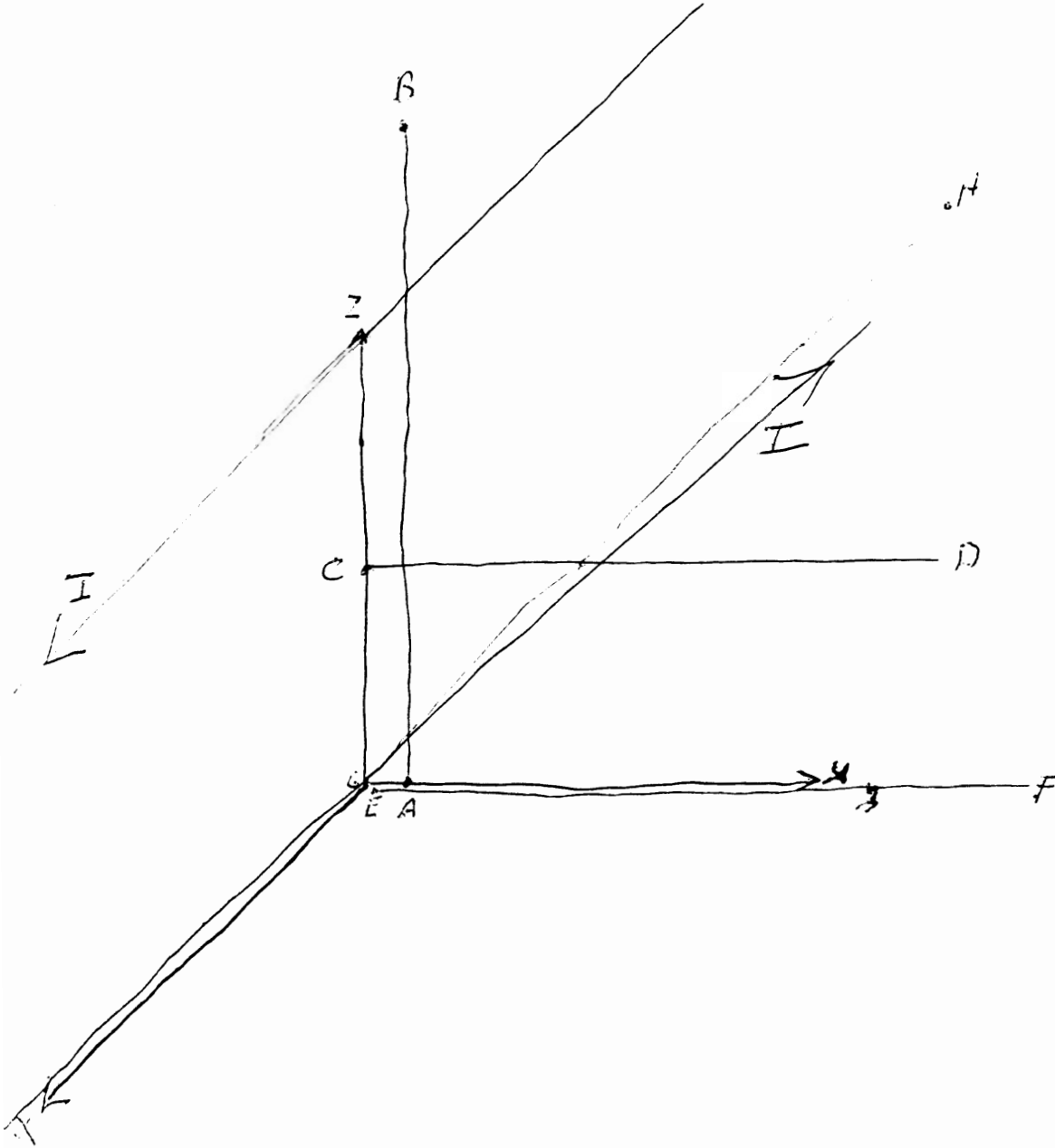

Trolley Wire Coordinate System For H Field Sampling

Figure 6-6

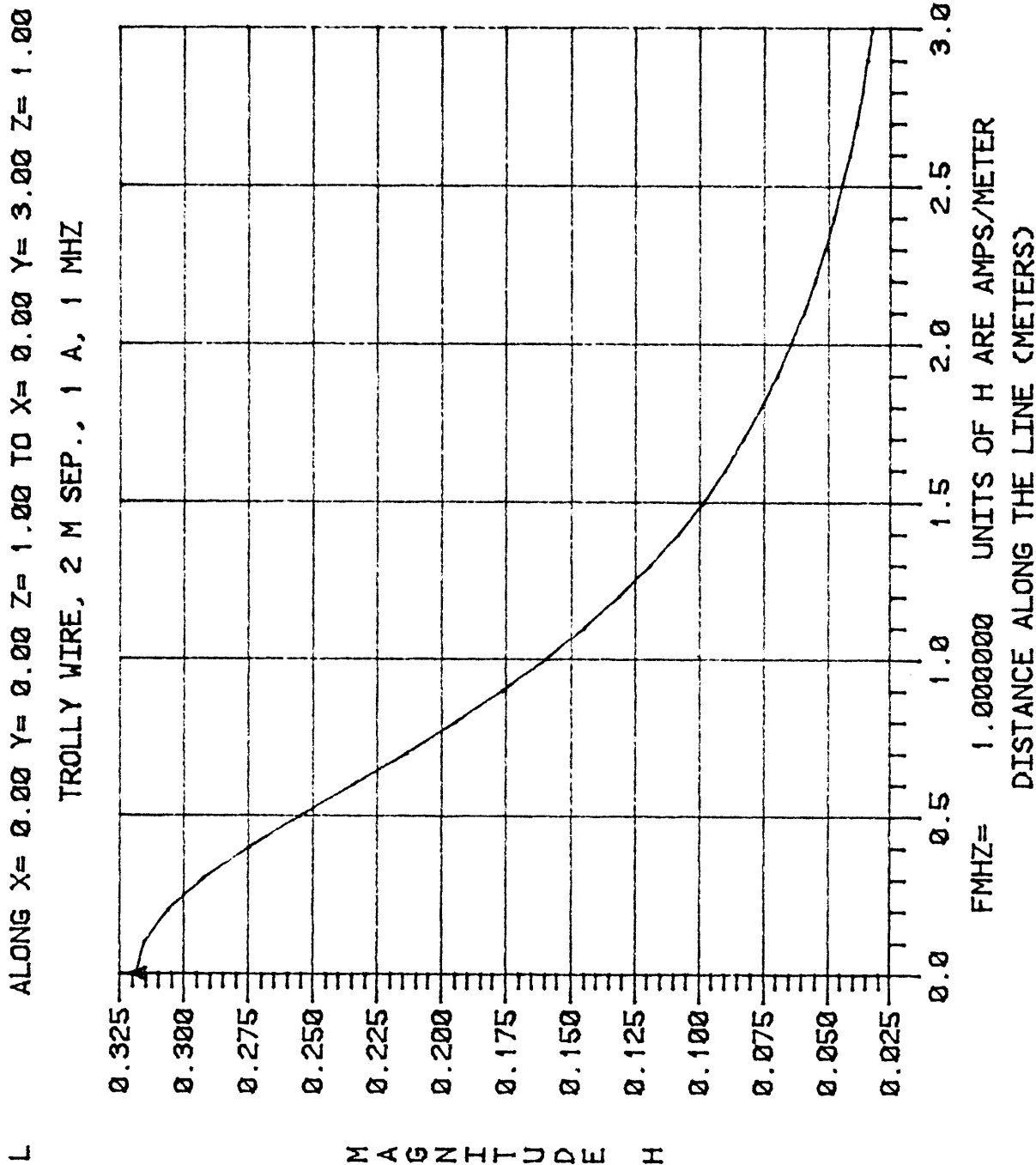

Figure 6-7

L ALONG X= 0.00 Y= 0.05 Z= 0.05 TO X= 0.00 Y= 3.00 Z= 3.00  
 TROLLEY WIRE, 2 M SEP., 1 A, 1 MHZ

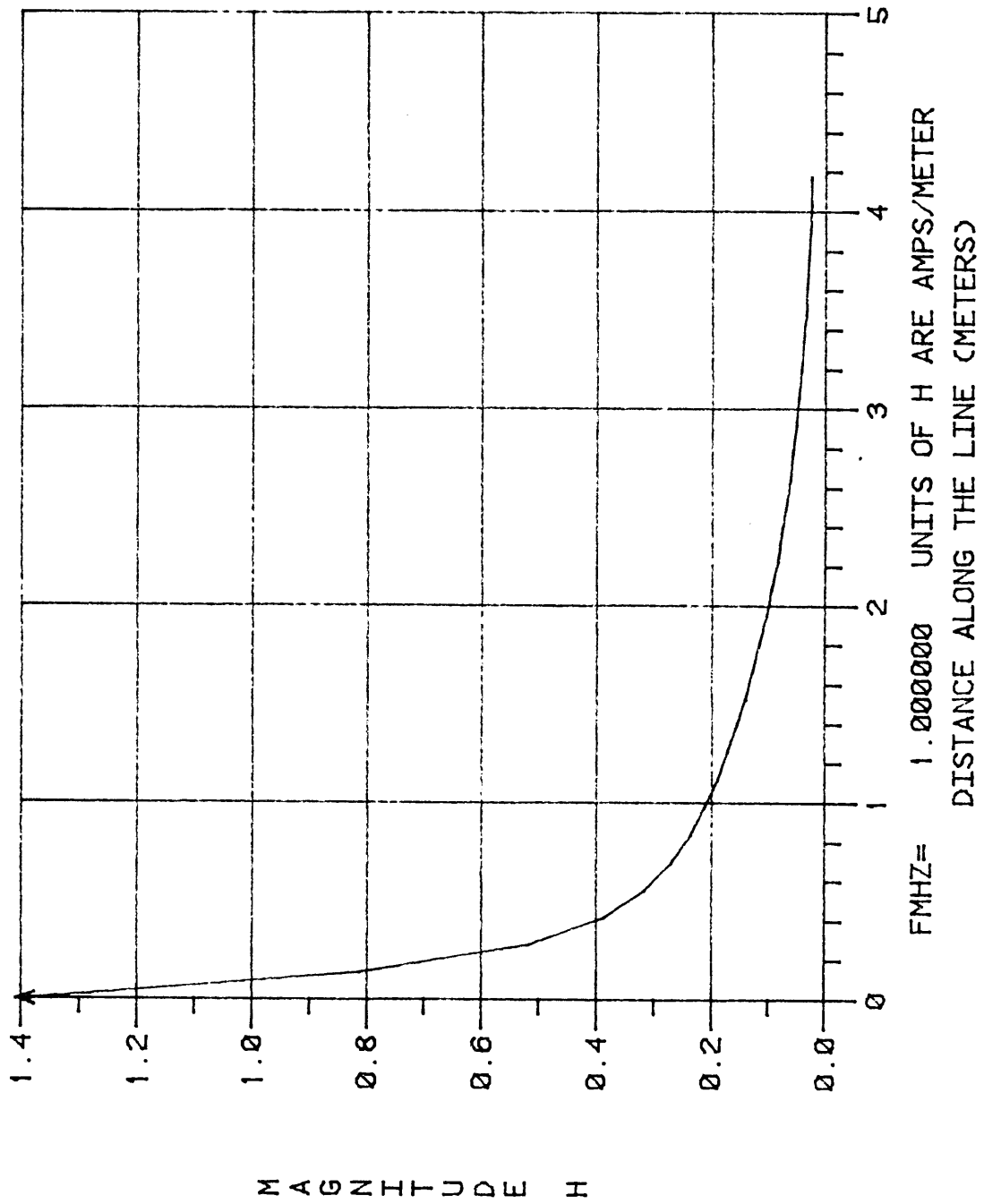

Figure 6-8

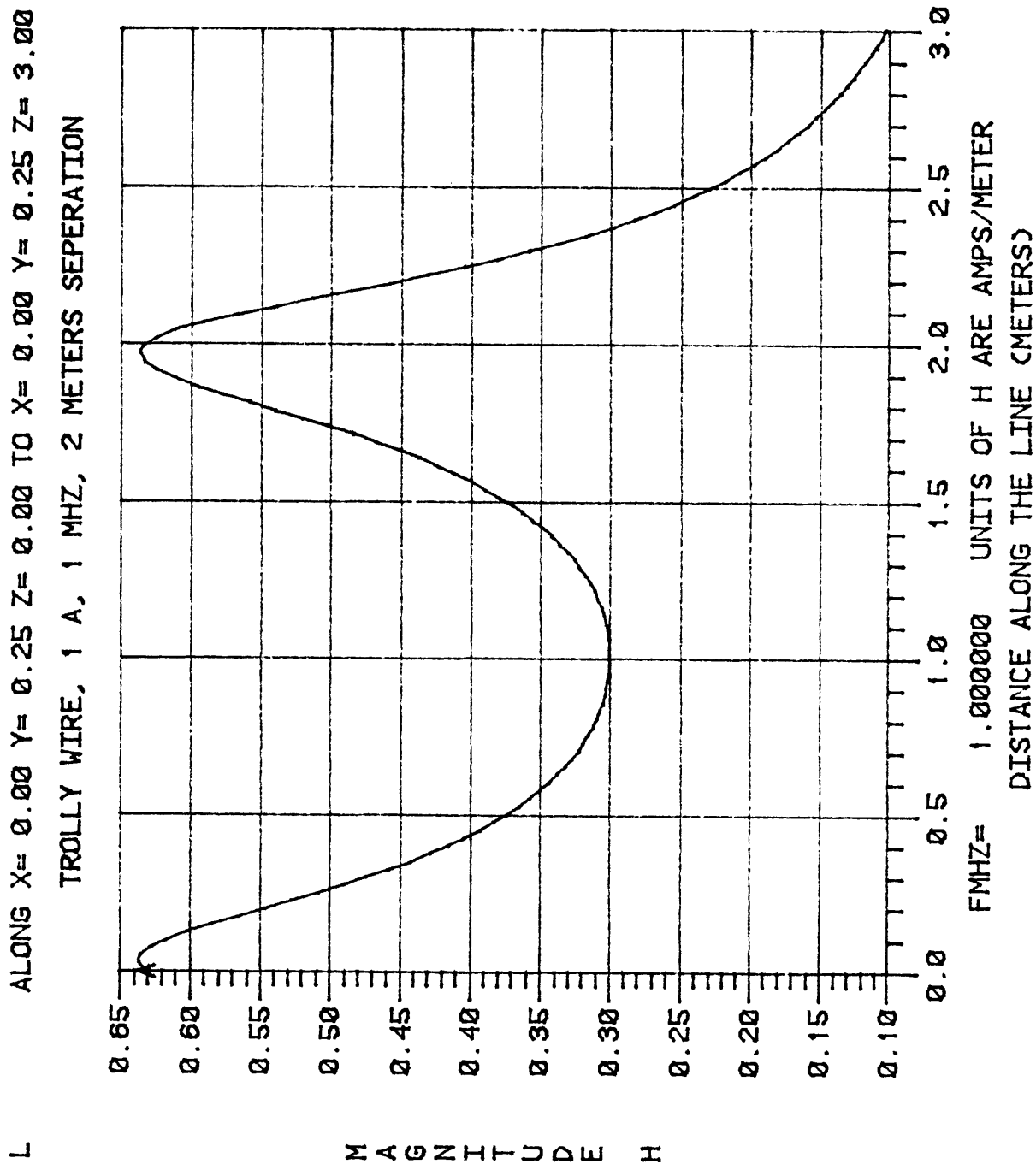



Figure 6-9

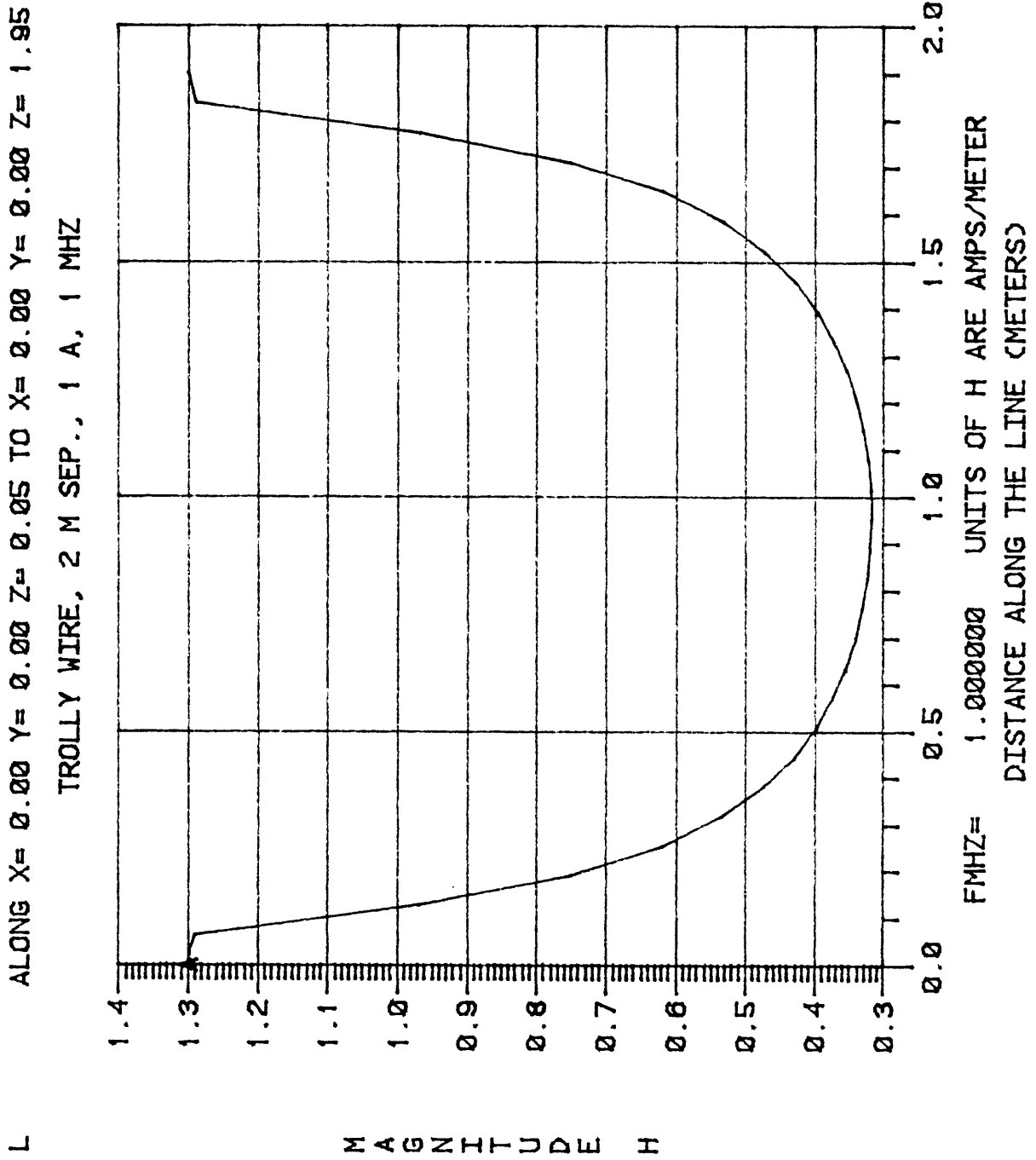

Figure 6-10

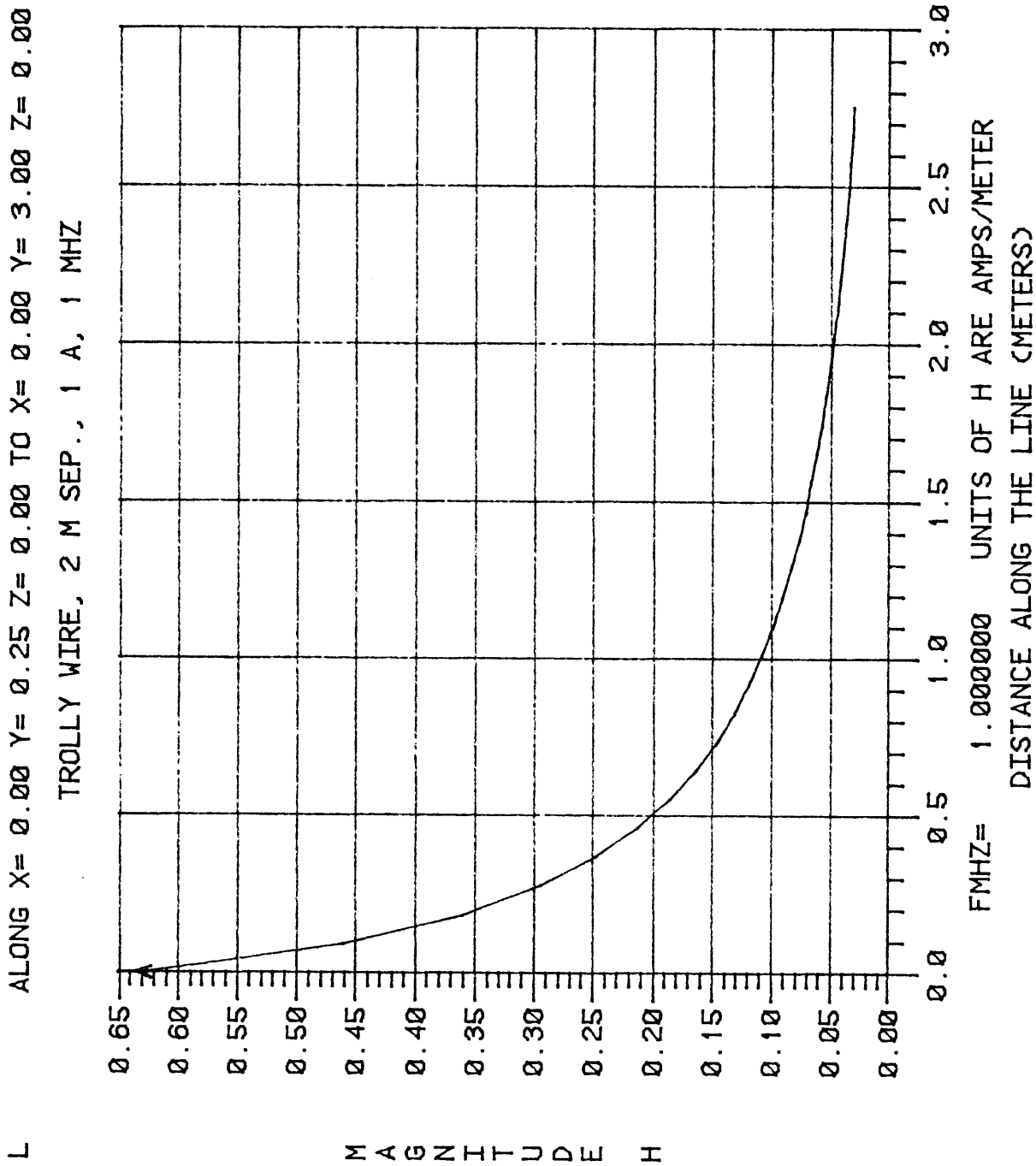

Figure 6-11

L ALONG X= 0.00 Y= 0.00 Z= 0.00 TO X= 3.00 Y= 0.00 Z= 3.00  
 LOOP, RADIUS= 0.5 METERS, 1 A, 1 MHZ

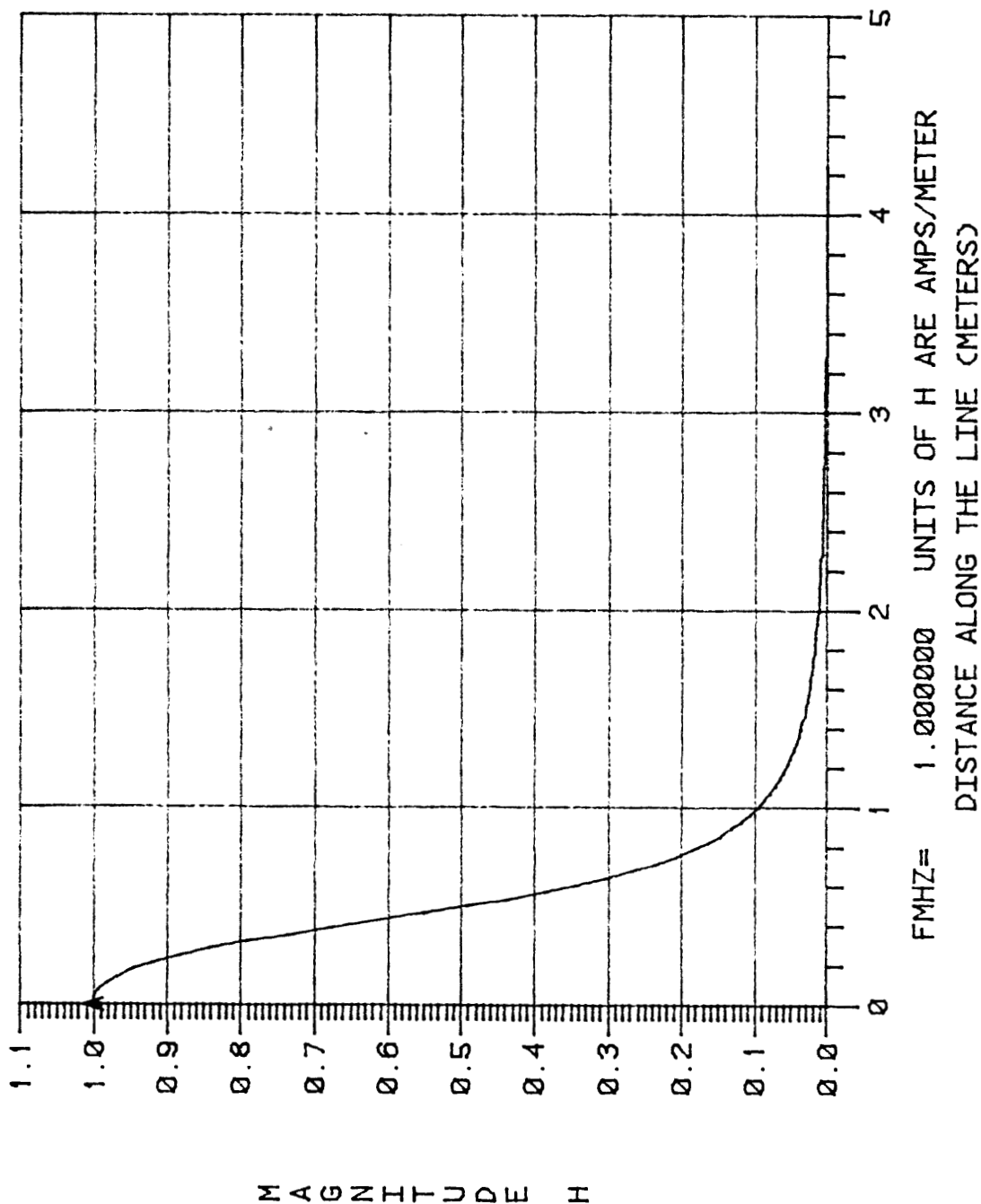

Figure 6-12

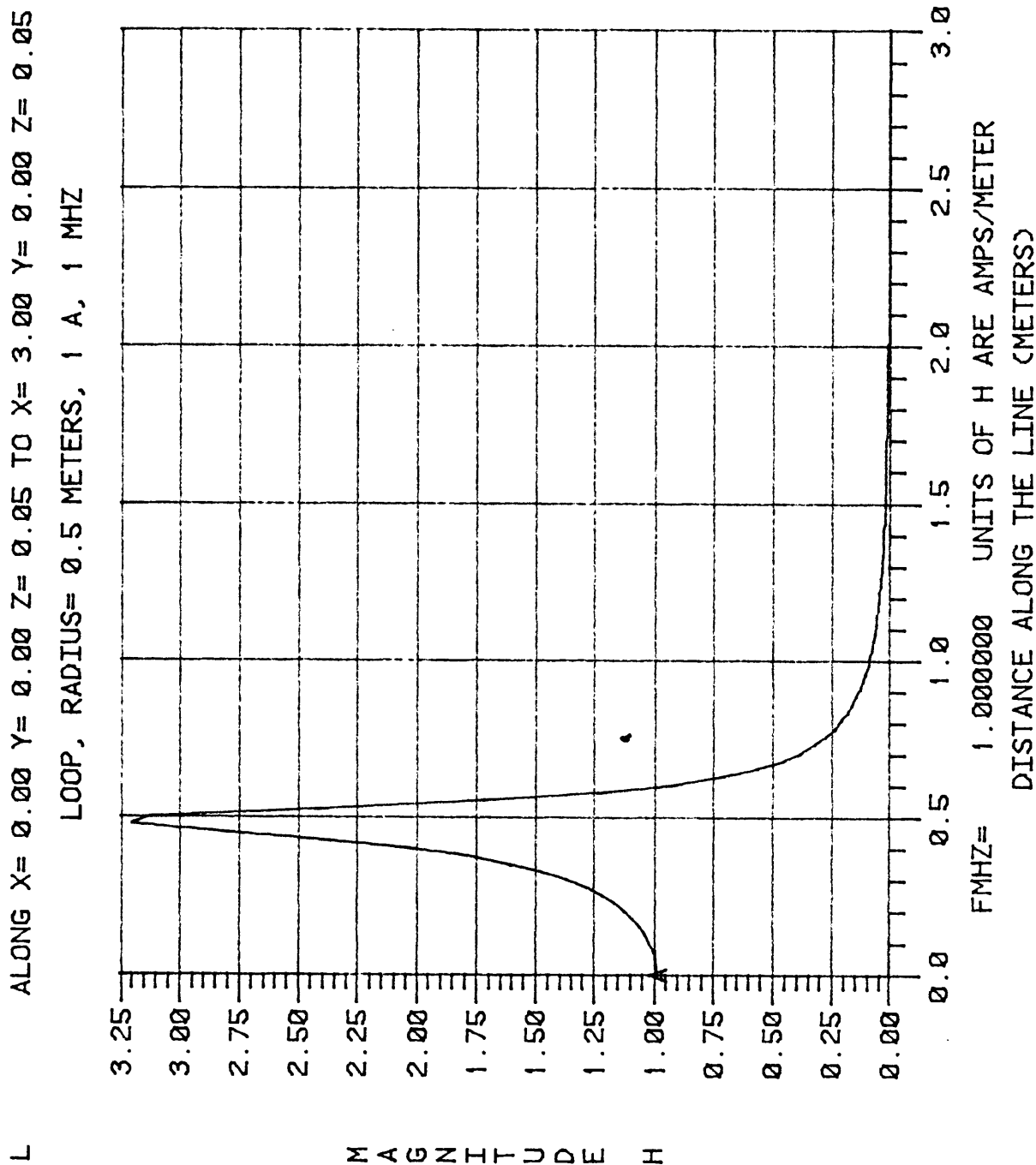

Figure 6-13

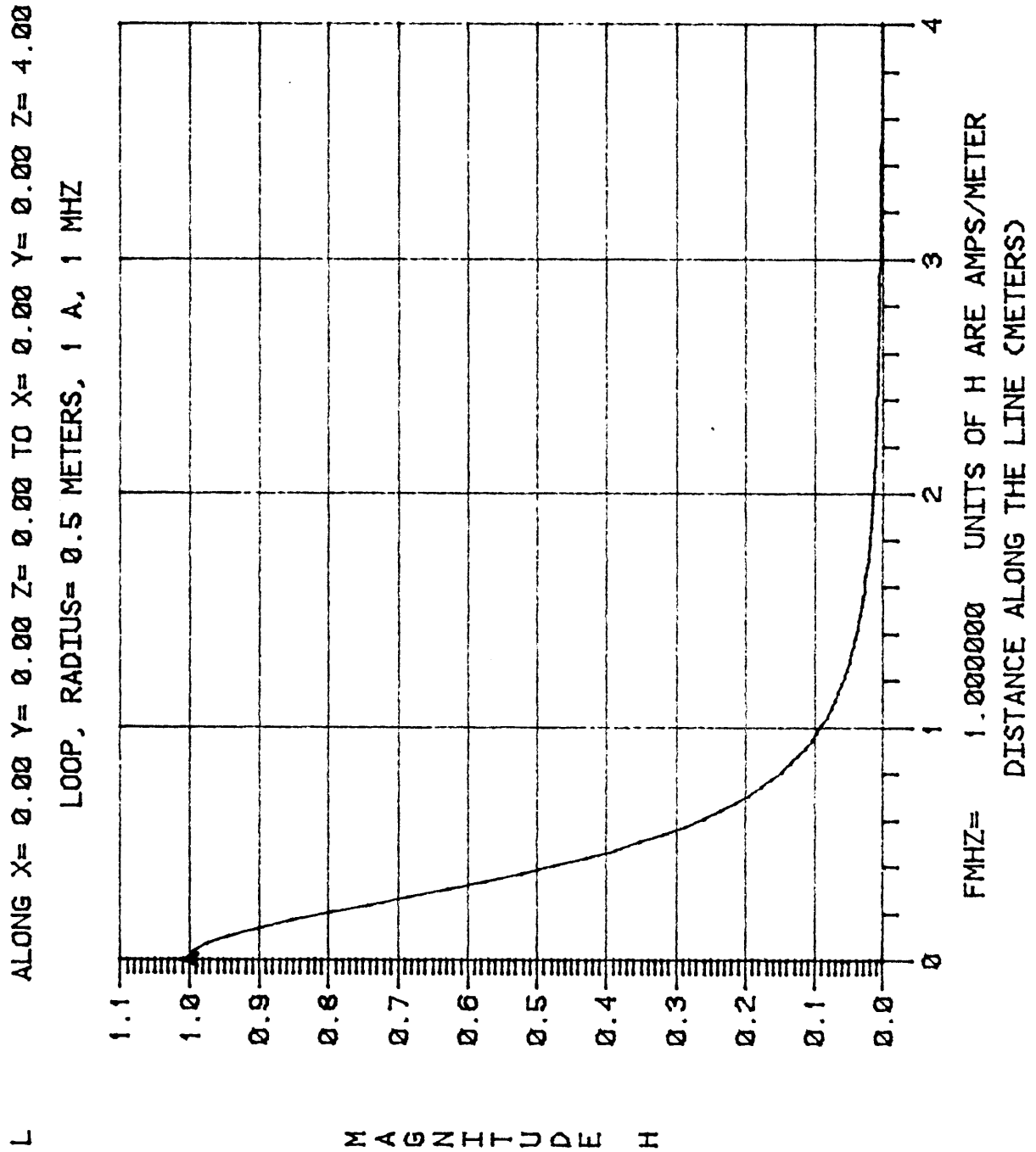
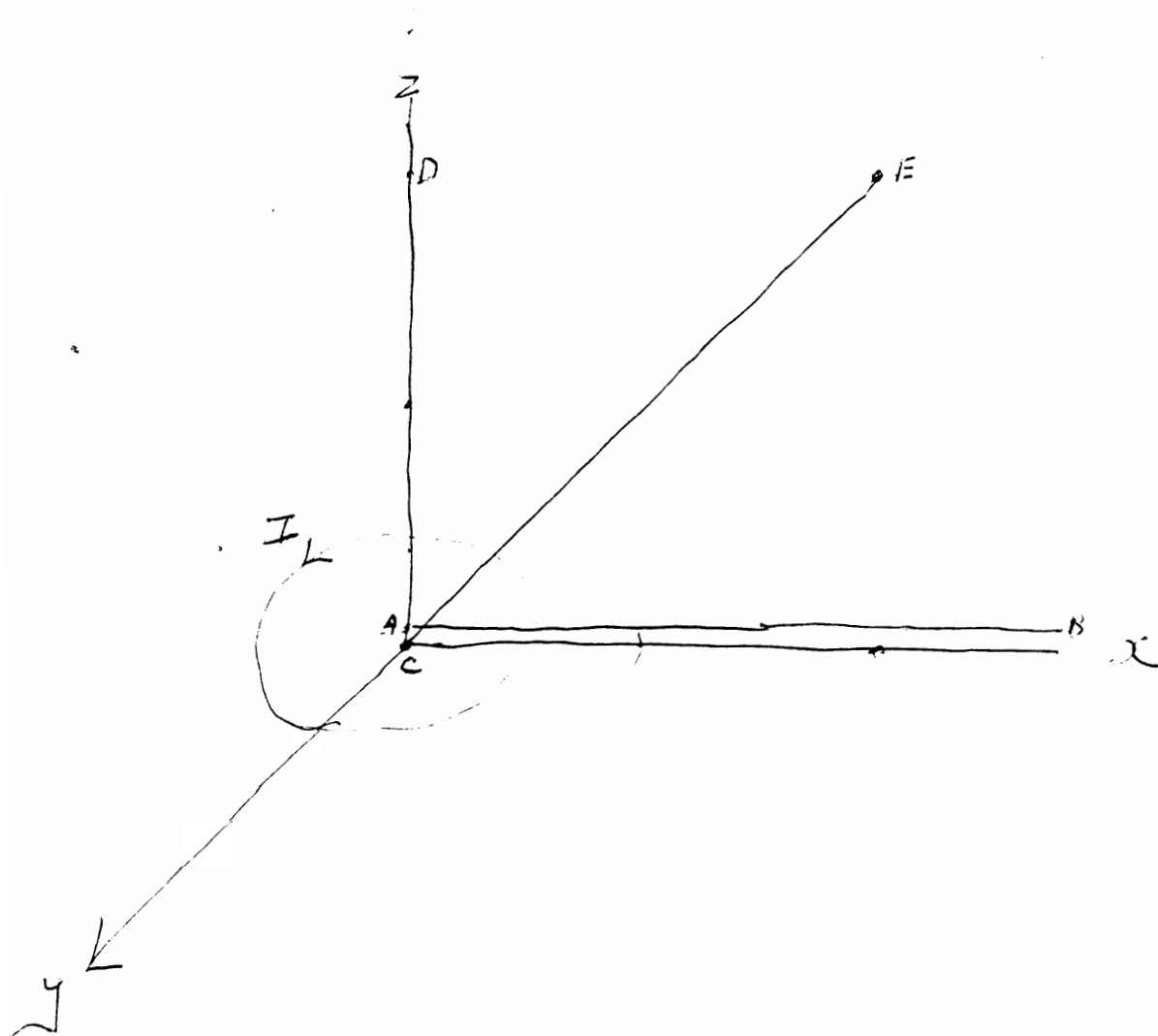

Figure 6-14

Loop Coordinate System  
for H Field Sampling



The loop is in the  $x, y$  plane, centered at the origin.

Figure 6-15

H Values at various points around the transmission line.

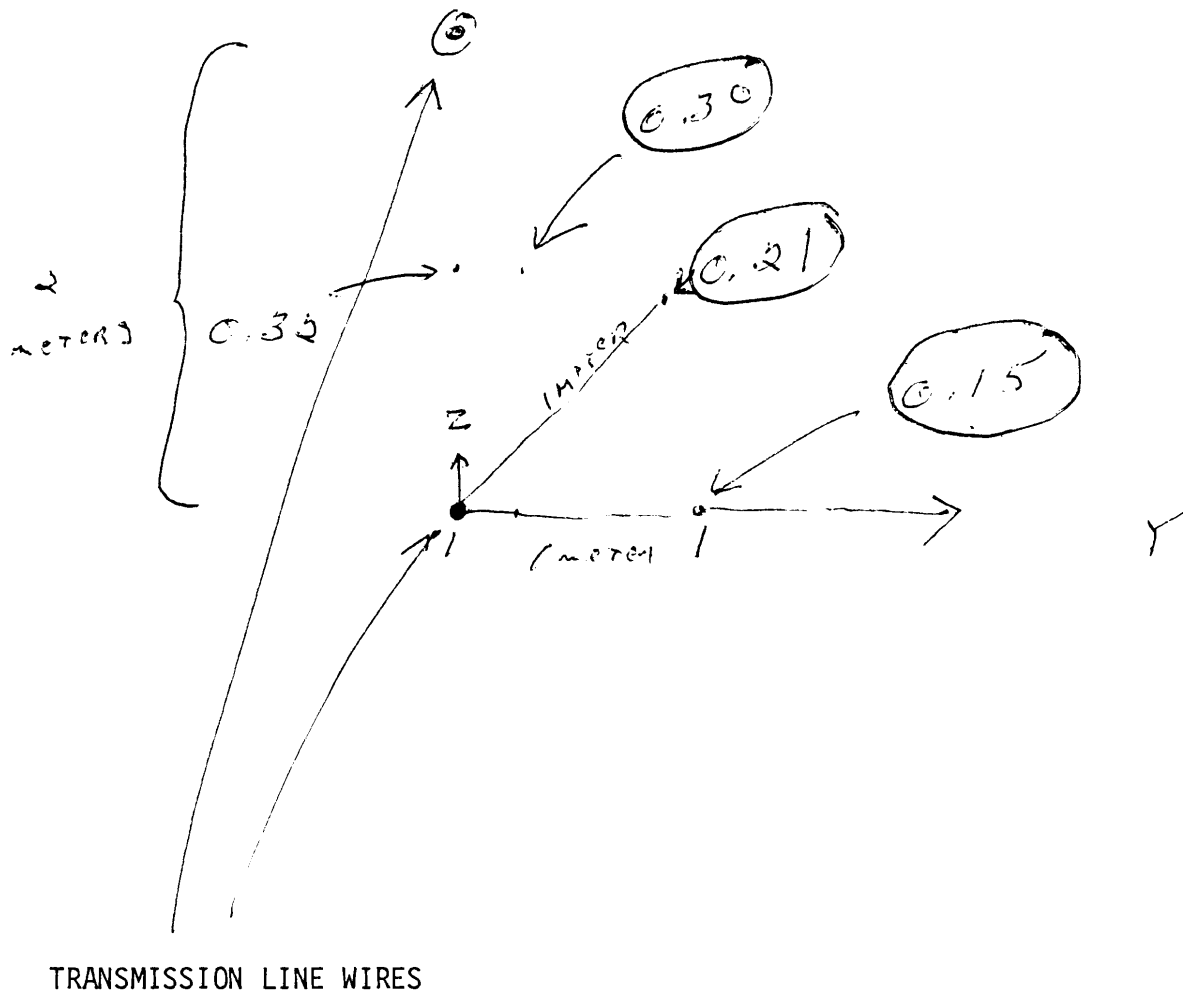
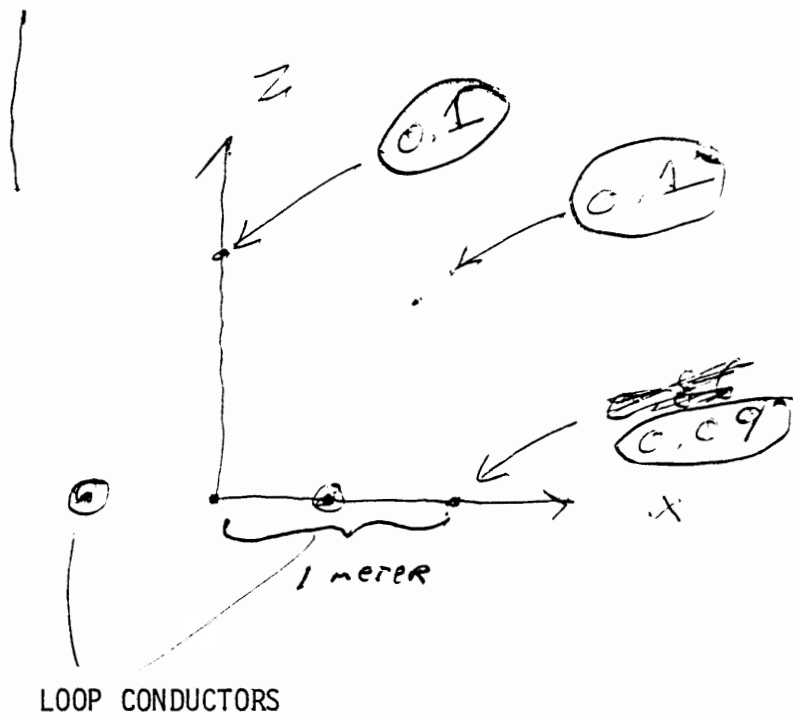

Figure 6-16

H Values at various points  
from the 0.5 M Radius Loop





varies as shown by the points in Figure 6-16. For the moment we can note that  $/H/ = 0.32$  for a 1 meter separation from the transmission line current carriers and  $/H/ = 0.1$  for a 1 meter separation from the loop source.

### 6.3 SAFE DISTANCES FROM TROLLEY PHONE LINE CONDUCTORS

A. D. Little's Mr. Robert LaGace has supplied us with data on mine trolley carrier phones -- see Appendix J -- that indicates that the carrier frequencies are no more than 0.190 MHz and the maximum short circuit current for the transmitters -- and therefore the maximum current on the trolley line -- is approximately 2.6 amperes RMS.

For a trolley phone operating at the worst-highest-frequency, say 200 KHz, and running into a shorted line with the short located precisely right -- about a half wavelength away (a distance somewhat smaller than 3000 meters or about 2 miles) with no loss in the lines, then the maximum current close to the end of the line near the short will be 2.6 amperes. The values of  $/H/$  given in Figure 6-15 multiplied by 2.6 and again multiplied by our correction factor of 5 (to account for the difference between free space and the mine environment) indicate that the maximum H field one meter from either transmission conductor line would be 4.16 or less. Indeed, since the return would be through the track, the 4.16 a/m figure would be high for a 1 meter separation from either rail.

If we consult Figure 6-4, we see that a blasting wiring loop of area 0.0316 square meters has a critical H field value,  $/H_c/$ , of 5.53 a/meter for 200 KHz. Thus, blasting wiring loops of less than 0.0316 square meters would be safe at .1 meter from any trolley phone conductor. This is the area of a square about 17.8 cms (about 8 inches) on a side or a circular loop formed of 63 cm (about 2 feet) of wire.

With the "worst case" trolley phone and a loop of this size at a point one meter from the trolley phone conductor wire we would still need to orient

the loop correctly to receive maximum power. At that orientation we assume that the "no fire" current -- the current that will function the cap with 0.1% probability at 95% confidence, i.e. 1 in 1000, 95% of the time, -- will flow in the cap. Our analysis has "worst case" several other factors however; we assume that the maximum  $B$  field can be normal to our loop over its total area of the blasting wiring; we assume that the cap lead wires are only as long as the loop periphery -- they are in general longer and will tend to reduce the current due to inductance and resistance --; and most important, we assume that our correction factor of 5 applies at all times and all places in the mines.

Each of these "worst case" factors, however, cannot be shown to be improbable. At some time they may all occur naturally together. So our overall result is that blasting cap wiring with areas of greater than 0.0316 sq. meters -- a square about 8 inches on a side -- not be brought closer than 1 meter to any trolley phone wire or track return.

Lest we convey the idea that our assumptions are so "worst case" as to be restrictive of cap use, consider a cap with six foot leg wires and the short still on the wires. If the leg wires were pulled apart in the middle forming an approximate 1 sq. meter loop and this loop were placed coplaner (plane of the loop in the plane of the trolley phone conductors) with the conductors of a normally operating trolley phone at 200 KHz with about 1.3 amps in the conductors, we can see from Figure 6-8 that the H field would be more than  $0.3 \times 1.32 = 0.4$  amp/meter over the loop assuming no correction factor of 5. Figure 6-4 shows the  $H_c$  for this area to be about 0.85 a/m. So we would be about a factor or two from the "no fire" level even if we were in free space. It is also wise to consider that the spread in currents for blasting caps from the "no fire" level to the "all fire" level -- 99.9% probability with 95% confidence -- is about 1.2 to 1.4, e.g. 1.25 times the "no fire" current level for at least one American-made cap gives the "all fire." So the total safety factor

separating us from a "sure fire" would be about  $2 \times 1.2 = 2.4$ . Study of the data taken in our mine measurements shows that, under some conditions, "correction factors" of much greater than 2.4 has been measured. This would convince me to leave the area quickly.

#### 6.4 SAFE DISTANCES FROM LOOP SOURCES

Study of Figures 6-11 and 6-13 shows that the magnetic field of the loop along the loop's axis is larger -- at a given distance from the center of the loop -- than the magnetic field in any other direction. The field variation along the axis has a particularly simple form.

$$H_a = \frac{I R_l^2}{2(R_l^2 + Z^2)^{3/2}} \quad (6-12)$$

where  $H_a$  is the H field on the axis,  
 $Z$  is distance (meters) from the center of the loop,  
 $R$  is the loop radius in meters, and  
 $I$  is the loop current in amperes.

For  $Z \gg R$

$$H_a \cong \frac{I R_l^2}{2 Z^3} = \frac{I \pi R_l^2}{2 \pi Z^3} = \frac{I A_l}{2 \pi Z^3} \quad (6-13)$$

where  $A_l$  is the area of the loop.

If we define the magnetic moment of the loop as

$$M_m = IA_l$$

where  $M_m$  is the magnetic moment ,

then for  $Z \gg R$

$$H_a \cong \frac{M_m}{2 \pi Z^3} \quad (6-14)$$

This definition allows us to treat small loop antenna sources without regard to the geometrical differences and actual number of turns. Note that equation 6-14 is valid only for  $Z \gg R_{\ell}$ . How much bigger is "much, much" bigger. Figure 6-17 plots H field variation for a  $R_{\ell} = 0.5$  meter loop along the Z axis. On this "log log" plot the slope of -3 at distances such that  $Z > 2R_{\ell}$  is readily apparent. We therefore write, with only very small error

$$H_z \cong \frac{M_m}{2\pi Z^3} \quad Z > 2R \quad (6-15)$$

To determine safe distances from loops we need only compare 5.0 times  $H_z$  in (6-15) to the  $|H_c|$  values of Figures 6-3 and 6-4 for various values of blasting wiring loops.

Mr. Larry Stolarczyk of the ARF Company of Raton, New Mexico, has informed us, by private communication, that the "back pack" and vehicular communication systems, that they manufacture for underground use, operate at frequencies of less than 400 KHz and that the magnetic moments of the antennas are 1.5 ampere turns meter<sup>2</sup> for the "back pack" system and 11.09 (6.3 x 11 x 0.16) for the vehicular system. Table 6-1 shows the results of substituting these values for  $M_m$  in

$$H_c(A) \Big|_{f=400\text{ KHz}} = \frac{M_m \cdot (5.0)}{2\pi Z^3} \quad (6-16)$$

and solving for Z. The values of  $H_c(A) \Big|_{f=400\text{ KHz}}$  are taken from Figure 6-4. Note that we have included the "correction factor" of 5 in (6-16)

Transmitting systems of this type are usually tuned for peak current and any malfunction of the system results in less current flowing in the antenna

Figure 6-17

ALONG X= 0.00 Y= 0.00 Z= 0.00 TO X= 0.00 Y= 0.00 Z=20.00  
 LOOP, RADIUS=0.5 METERS, I A, 1 MHZ

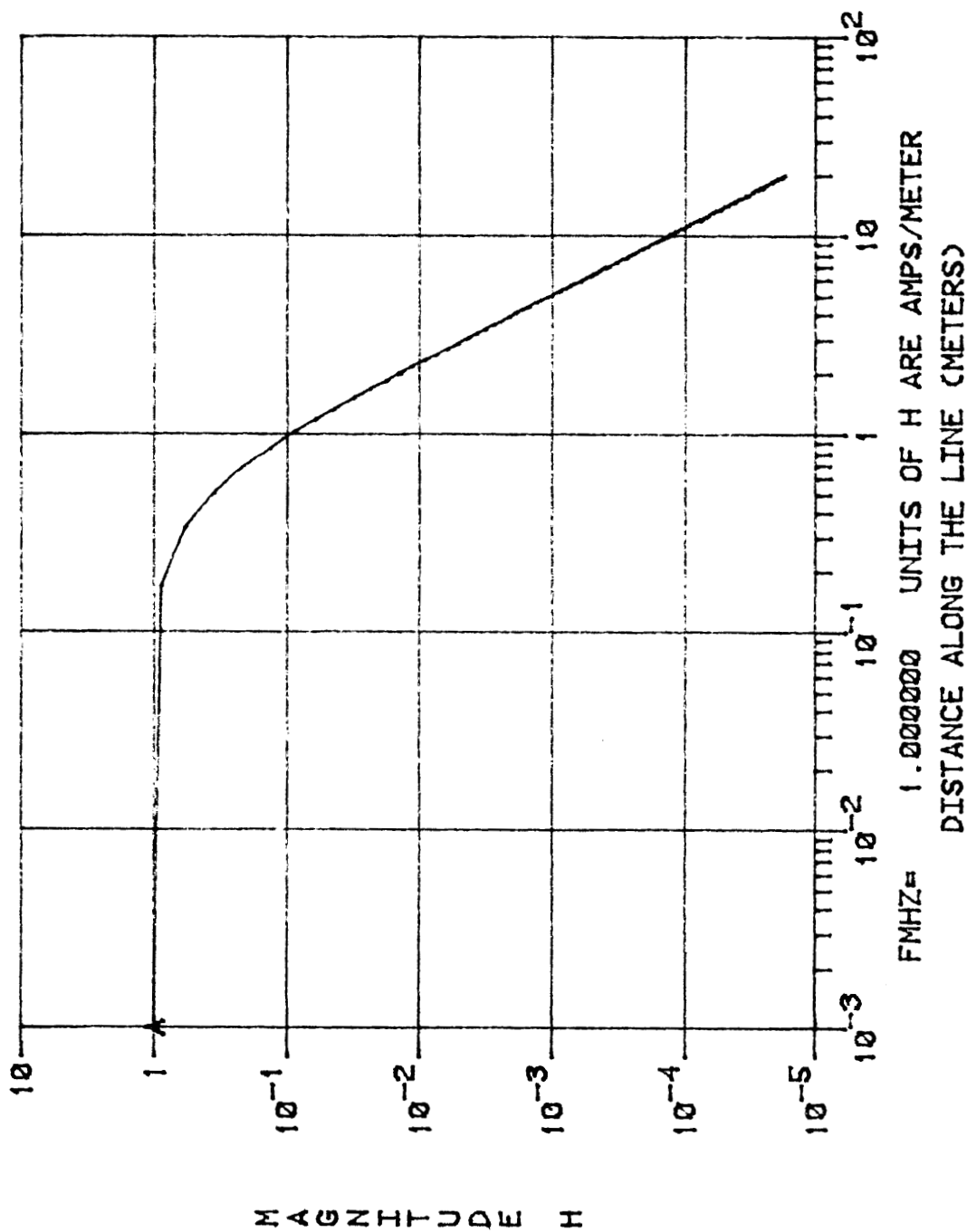

Table 6-1. Values for Safe Distance (Z) for ARF Transmitter Antennas

Blasting Wire Area (sq. m)	Safe Distance (Z) (meters)		/H <sub>C</sub> / amp/meter
	Vehicular System M <sub>m</sub> =11.088	"Back Pack" System M <sub>m</sub> =1.5	
0.0316	1.28	0.65	4.19
0.10	1.54	0.79	2.35
0.316	1.84	0.96	1.39
1.00	2.19	1.13	0.84
3.16	2.58	1.33	0.51
10.00	3.06	1.55	0.31

than the design value. We therefore feel that the above distances are valid even for equipment malfunction conditions.

Note that a blasting wiring configuration having a 10 square meter area is large indeed. This is the area of a typical blasting face layout -- the maximum we would expect to see underground. Table 6-1 shows that we would be safe -- even for 10 sq. meters of blasting wiring loop area -- if such portable transmitter equipment is always kept about 3 meters from any blasting wiring. This is a convenient number in that any electronic or electrical equipment should always be kept five (about 1.55 meters) or ten feet (about 3.06 meters) from any portion of a blasting wiring layout to eliminate potential premature firings due to dropping the equipment on the wiring or due to a man carrying (body mounted) equipment falling on or into the wiring and having the equipment come in contact with the blasting wiring.

Safe distances from other underground loop sources such as "bandolier" antennas can be calculated by the same methods as used above if the frequency exceeds 400 KC and/or the magnetic mount exceeds 11.09 amp-turns-meters squared.

#### 6.5 SUMMARY OF SAFE DISTANCES AND COMMENT

Section 6.3 recommends that blasting wiring with areas of greater than 0.0316 square meters -- a square about 8 inches on a side or a circle formed from 2 feet of wire -- not be brought closer than 1 meter to any trolley phone wire or track return. Certainly no blasting wiring should approach even this close to a "hot" dc trolley wire.

This recommendation can be implemented most easily by prohibiting any blasting operation in a haulage way containing an operating trolley phone. The recommendation would allow, however, a shot line from a remote blasting wiring configuration to be run into (or along) a haulage way that contains an

operating trolley phone. Thus firing could be done from the haulage way if care is taken to keep the shot line conductors close together so that any shorted loop is less than 64 sq. inches in area.

Section 6.4 recommends that the "back pack" and vehicular antennas (operating at less than 400 KHz) made by ARF be kept respectively 5 feet and 10 feet from blasting wiring of 10 square meters area to preclude RF hazard. In essence this recommendation says that as long as these antennas are restrained from being within 10 feet of any blasting wiring configuration we eliminate the possibility of RF hazard. Since the hazard separation distance would be smaller for smaller areas, one might conclude that smaller separations are desirable for smaller blasting wiring areas. We do not believe so. Some minimum distance should be provided to eliminate accidental contact between the blasting wires and the transmitting equipment.

Note that we have considered here only the shorted blasting wire configuration. For frequencies and sources below 10 MHz at the distances considered, the entire possibility of RF hazards to blasting caps is eliminated by keeping the blasting circuit open. We do not recommend this procedure however. Caps are shipped shorted with the leg wires configured so as to form a minimum coupling area. Good blasting practice -- dictated by consideration of electrostatic hazards and stray currents -- requires that blasting circuits be kept shorted. We agree.

Also note that we have considered only the pin-to-pin firing mode of the caps. American-made caps require very high voltages to function in the pin-to-pin case mode for the frequency range up to 10 MHz. The open circuit voltages produced by the sources considered in the blasting wiring pin-to-case loops is extremely small for the separations recommended and thus safety for the pin-to-pin mode insures -- for the conditions considered here -- safety for the pin-to-case mode.



## 7.0 REFERENCES

1. "Investigations of the RF Hazards to Electric Blasting Caps" - FIRL Technical Report F-B2256, R.H. Thompson, P.F. Mohrbach, et al -- prepared for the Institute of Makers of Explosives, 1965.
2. "RF Pickup of Antenna Simulating Blasting Wiring Configurations, Measurement Results" -- FIRL Technical Report F-B2256-2, R.H. Thompson -- prepared for the Institute of Makers of Explosives, 1966.
3. "Measurements of the RF Coupling Between an Antenna Simulating a Blasting Wiring Configuration and Nearly Mobile Transmitting Antenna," FIRL Technical Report F-C1951, R.H. Thompson, K. Fertner -- prepared for the Institute of Makers of Explosives, 1967.
4. "The Possible RF Hazard to Blasting Caps Caused by a Lossy Communication System" -- FIRL Technical Report F-C2399, R.H. Thompson, P.F. Mohrbach -- prepared for Motorola, Inc., 1969.
5. "RF Pickup of Blasting Face Wiring" -- FIRL Technical Report F-C2942, R.H. Thompson -- prepared for Motorola, Incorporated, 1970.
6. "Evaluation and Determination of Sensitivity and Electromagnetic Interaction of Commercial Blasting Caps" -- FIRL Technical Report F-C3102, HO210068, August 1973.
7. "RF Hazards to Blasting Caps in Coal Mines" -- FIRL Technical Report F-C4075, R.H. Thompson -- prepared for U.S. Bureau of Mines under Contract HO252015, October 1976.
8. "Fields and Waves in Communication Electronics," Ramo, Whinnery & Van Duzer, 1965, John Wiley & Sons, NY, NY.