



**report**

*Collins Radio Company*

*Volume 4 Environmental Measurements*

**Research and Development Contract  
for Coal Mine Communication System**



**report**

*Volume 4 Environmental Measurements*

---

# **Research and Development Contract for Coal Mine Communication System**

---

*Prepared for Department of Interior  
Bureau of Mines  
Washington, D.C.  
USBM Contract No. H0232056*

---

*Printed in the United States of America*

**Disclaimer Notice:** "The views and conclusions contained in this document are those of the authors and should not be interpreted as necessarily representing the official policies of the Interior Department's Bureau of Mines or the US Government."

Table of Contents

|  | Page |
|--|------|
| Section 1 Introduction .....   | 1-1  |
| Section 2 Experimental UHF and VLF Tests<br>at the Inland Steel Mine ..... | 2-1  |
| 2.1 UHF Tests .....  | 2-1  |
| 2.2 VLF Tests .....  | 2-2  |
| 2.3 Test Site.....   | 2-3  |
| 2.4 Propagation Characteristics .....                                      | 2-3  |
| 2.4.1 UHF Propagation .....  | 2-9  |
| 2.4.2 Experimental VLF Propagation.....                                    | 2-17 |
| 2.4.3 Summary and Conclusion.....  | 2-25 |
| 2.5 Acknowledgment.....  | 2-26 |
| 2.6 References.....  | 2-26 |
| Section 3 Experimental VLF to LF Tests at<br>Robena No. 1 Mine .....       | 3-1  |
| 3.1 VLF and LF Tests.....  | 3-1  |
| 3.2 Comparison of VLF Predictions.....                                     | 3-11 |
| 3.3 VLF Summary .....  | 3-17 |
| 3.4 Tables.....  | 3-17 |
| Section 4 UHF Predictions .....  | 4-1  |
| Appendix A Test Equipment and Experimental<br>Setups                       |      |
| Appendix B Tables  |      |

## List of Illustrations

| Figure   | Page |
|--|------|
| 2-1 Coal Mine Test Site .....  | 2-5  |
| 2-2 Tunnel Cross Section .....   | 2-7  |
| 2-3 Corner No. 1 Layout .....  | 2-8  |
| 2-4 Corner No. 2 Layout .....  | 2-8  |
| 2-5 Observed 200-MHz Transmission Loss for a<br>Straight Coal Mine Tunnel .....                | 2-10 |
| 2-6 Observed 415-MHz Transmission Loss for a<br>Straight Coal Mine Tunnel .....                | 2-11 |
| 2-7 Observed 1000-MHz Transmission Loss for a<br>Straight Coal Mine Tunnel .....               | 2-12 |
| 2-8 200-MHz Corner Attenuation for Coal Mine Tunnel....  | 2-14 |
| 2-9 415-MHz Corner Attenuation for Coal Mine Tunnel....  | 2-15 |
| 2-10 1000-MHz Corner Attenuation for Coal Mine<br>Tunnel .....                                 | 2-16 |
| 2-11 Observed Transmission Loss for Roof-Bolt<br>Antennas in Coal Mine .....                   | 2-18 |
| 2-12 Observed Transmission Loss for Roof-Bolt<br>Antennas in Coal Mine .....                   | 2-19 |
| 2-13 Observed Transmission Loss for Roof-Bolt<br>Antennas in Coal Mine .....                   | 2-20 |
| 2-14 Observed Field Strength for Roof-Bolt-to-Loop<br>Antennas in Coal Mine .....              | 2-22 |
| 2-15 Observed Field Strength for Roof-Bolt-to-Loop<br>Antennas in Coal Mine .....              | 2-23 |
| 2-16 Observed Field Strength for Roof-Bolt-to-Loop<br>Antennas in Coal Mines .....             | 2-24 |
| 3-1 8-Inch Loop to 20-Meter Loop.....  | 3-1  |
| 3-2 Line Source to Loop.....   | 3-2  |
| 3-3 Line Source to Loop.....   | 3-2  |
| 3-4 Received Signal Vs Frequency (8-Inch Loop to<br>20-Meter Loop) .....                       | 3-3  |
| 3-5 Received Signal Vs Frequency (8-Inch Loop to<br>Roof Bolt) .....                           | 3-4  |
| 3-6 Received Signal Vs Frequency (Roof-Bolt to<br>8-Inch Loop) .....                           | 3-5  |
| 3-7 Received Signal Vs Frequency (20-Meter Loop to<br>8-Inch Loop) .....                       | 3-6  |
| 3-8 $S/N_0$ Vs Separation (Roof-Bolt to 8-Inch Loop) .....                                     | 3-7  |
| 3-9 $S/N_0$ Vs Separation (20-Meter Loop to 8-Inch Loop<br>and Roof Bolt to 8-Inch Loop) ..... | 3-8  |
| 3-10 $S/N_0$ Vs Separation (8-Inch Loop<br>to Roof Bolt).....                                  | 3-9  |
| 3-11 $S/N_0$ Vs Separation (8-Inch Loop to 20-Meter Loop) .                                    | 3-10 |

List of Illustrations (Cont)

| Figure   | Page |
|--|------|
| 3-12 S/N <sub>0</sub> Vs Separation (8-Inch Loop to 20-Meter Loop) .....   | 3-12 |
| 3-13 S/N <sub>0</sub> Vs Separation (Roof-Bolt to Loop Transmission) .....   | 3-13 |
| 3-14 S/N <sub>0</sub> Vs Separation (20-Meter Loop to 8-Inch Loop) .....   | 3-14 |
| 3-15 Lateral Magnetic Field Intensity for Varying Displacement .....   | 3-18 |
| 4-1 UHF Propagation (1-Watt Transceiver Transmitting to 1-Watt Transceiver - 1,800 ft) .....                         | 4-2  |
| 4-2 UHF Propagation (1-Watt Transceiver Transmitting to 1-Watt Transceiver - 3,300 ft) .....                         | 4-3  |
| 4-3 UHF Propagation (20-Watt Transceiver Transmitting to 1-Watt Transceiver - 2,000 ft) .....                        | 4-4  |
| 4-4 UHF Propagation (20-Watt Transceiver Transmitting to 1-Watt Transceiver - 3,800 ft) .....                        | 4-5  |
| 4-5 UHF Propagation (1-Watt Transceiver Transmitting to 1-Watt Transceiver With Corner Reflectors - 1,800 ft) .....  | 4-6  |
| 4-6 UHF Propagation (1-Watt Transceiver Transmitting to 1-Watt Transceiver, With Corner Reflectors - 3,300 ft) ..... | 4-7  |
| 4-7 UHF Propagation (20-Watt Transceiver Transmitting to 1-Watt Transceiver With Reflectors - 2,000 ft) ....         | 4-8  |
| 4-8 UHF Propagation (20-Watt Transceiver Transmitting to 1-Watt Transceiver With Corner Reflectors - 3,800 ft) ..... | 4-9  |
| 4-9 UHF Propagation (20-Watt Transceiver Transmitting to 1-Watt Transceiver With Corner Reflectors - 2,000 ft) ..... | 4-10 |
| 4-10 UHF Propagation (1-Watt Transceiver Transmitting to 1-Watt Transceiver With Corner Reflectors - 3,300 ft) ..... | 4-11 |
| A-1 UHF Test Setup.....  | A-2  |
| A-2 VLF Test Setup.....  | A-2  |
| A-3 Antenna Complement for Coal Mine Tests .....   | A-3  |
| A-4 415-MHz Corner Reflector Assembly .....  | A-4  |
| A-5 Corner Attenuation Curves for Coverage Predictions.....  | A-5  |

## List of Tables

| Table   | Page |
|---|------|
| 2-1 UHF Test Parameters .....   | 2-1  |
| 2-2 VLF Test Parameters .....   | 2-2  |
| 2-3 Observed Attenuation Rates for a Straight Coal<br>Mine Tunnel ..... | 2-9  |
| 2-4 Observed Attenuation At Tunnel Edges Relative<br>To Center .....    | 2-13 |
| 2-5 Observed Corner Reflector Gain .....                                | 2-16 |
| 2-6 UHF Noise Sensitivity Threshold .....                               | 2-17 |
| 3-1 Roof-Bolt Antenna Measurements, Robena No. 1 .....                  | 3-15 |
| 3-2 Roof-Bolt Antenna Measurements, Robena No. 1 .....                  | 3-17 |
| B-1 Roof-Bolt Transmitter, 8-Inch Receiver Loop .....                   | B-1  |
| B-2 Large Loop Transmitters, 8-Inch Receive Loop .....                  | B-2  |
| B-3 8-Inch Transmit Loop .....  | B-4  |
| B-4 Roof-Bolt and Large-Loop Transmission .....                         | B-5  |
| B-5 8-Inch Transmit Loop Normalized to 10-W, 1-Hz<br>Bandwidth .....    | B-5  |
| B-6 Large Loop Transmission .....                                       | B-7  |
| B-7 Roof-Bolt Transmission .....  | B-8  |
| B-8 Small-Loop Transmission .....                                       | B-9  |

This report summarizes the results of several field tests conducted by Collins for the Bureau of Mines under contract S0122076 and contract H0232056. The field projects represent a part of Collins continuing effort on a broad study of coal mine communications.

These experiments analyze the propagation characteristics of radio signals in a working coal mine environment. The intent of the program is to provide basic propagation loss characteristics by which we may evaluate various approaches to an integrated mine communications system. The goal of such a system is to satisfy both operational and emergency communications needs in the mine.

Field testing was conducted during the last week of November 1972, at a coal mine operated by Inland Steel Company, near Sesser, Ill, and in the Robena No. 1 Mine, Waynesburg, Pa, on 12 March 1974. The tests included uhf propagation losses and noise (200 MHz to 1 GHz) in the Sesser, Ill mine location and vlf propagation loss and noise (1 to 200 kHz) in both of the above locations. The basic experimental parameters were frequency, polarization, antenna type/orientation, and distance.

The following reports treat the various aspects of the test programs in detail. Since different antenna configurations were used in the two mines, each report contains its own experimental predictions drawn from its corresponding test activities.

A test equipment list and block diagrams of typical experimental setups for the tests of section 2 are contained in appendix A.

---

 Experimental UHF and VLF Tests at the  
 Inland Steel Mine

The coal mine test program has substantially followed the test plans and procedures as presented to Bureau of Mines personnel at a program review held in Cedar Rapids on 20 October 1972. The original scope of vlf testing was reduced slightly to accommodate uhf corner reflector tests. Propagation loss and noise measurements were conducted in two regions of the radio spectrum, 200 MHz to 1 GHz (uhf) and 1 to 50 kHz (vlf).

Paragraphs 2.1 and 2.2 explain these tests in further detail.

### 2.1 UHF TESTS

Primary emphasis of the test program was on uhf propagation characteristics in mine tunnels. The basic measurements include transmission loss along tunnels and around corners and received noise level. The variable parameters include frequency, polarization, distance, and the orientation of corner reflectors, when used. Table 2-1 shows the various test types and associated parameters.

Table 2-1. UHF Test Parameters.

| FREQUENCY | SIGNAL LEVEL     |                       |                     | SPOT NOISE           |
|-----------|------------------|-----------------------|---------------------|----------------------|
|           | DISTANCE<br>(ft) | POLARIZATION          | CORNER<br>REFLECTOR |                      |
| 200 MHz   | 0 to 800         | Vert, cross           | None                | At each signal point |
| 415 MHz   | 0 to 2000        | Vert, cross,<br>horiz | Yes                 | At each signal point |
| 1000 MHz  | 0 to 2750        | Vert, cross,<br>horiz | Yes                 | At each signal point |

Propagation characteristics were determined by measuring signal and noise levels at selected points in the mine. A 20-watt uhf transmitter and  $\lambda/4$  ground-plane antenna were used as a fixed source of signals. The receiver consisted of a battery-powered field intensity meter and standard dipole antenna of the type normally used for field strength measurements. The receiving apparatus was transported to the measurement points by a battery-powered mine scooter. Before any measurements were made, the scooter was driven into a crosscut to prevent interference with signals in the main tunnel. Specific test equipment types and experimental setups are described in appendix A.



At each receive point, a series of measurements was made to determine local signal strength variation over a range of several wavelengths. Horizontal and vertical polarization measurements were conducted to determine the extent of signal depolarization. Measurements were continued along straight tunnels and around corners at appropriate intervals determined by the rate of signal attenuation. Measurements were continued outward from the transmitter until no further signal could be detected. Spot noise measurements were made at each point by tuning the receiver slightly above or below the transmitter signal and observing the incident noise level.

Throughout the field measurements, 1-watt uhf walkie talkies (460 MHz) were used for coordination between the fixed transmitter and mobile receiver locations. Owing to the 20-watt transmitter power and propagation differences, the measurement range often exceeded the walkie talkie range. In these cases, a relay point was established to maintain coordination for polarization changes, etc. Qualitative performance of the walkie talkies was recorded along with signal/noise measurements for later comparison.

## 2.2 VLF TESTS

Phase two of the field measurements concentrated on the vlf propagation characteristics of intramine paths. Basic measurements include transmission loss or field strength and noise levels. The variable parameters include frequency, distance, receive antenna type, and antenna orientation. Table 2-2 shows the various test types and associated parameters.

Table 2-2. VLF Test Parameters.

| FREQUENCY | SIGNAL LEVEL  |                  | SPOT NOISE           |
|-----------|---------------|------------------|----------------------|
|           | DISTANCE (ft) | *ANTENNA         |                      |
| 1 kHz     | 0 to 675      | Loop, roof bolts | At each signal point |
| 3 kHz     | 0 to 675      | Loop, roof bolts | At each signal point |
| 10 kHz    | 0 to 675      | Loop, roof bolts | At each signal point |
| 20 kHz    | 0 to 675      | Loop, roof bolts | At each signal point |
| 50 kHz    | 0 to 675      | Loop, roof bolts | At each signal point |

\*Each loop measurement includes readings for three orthogonal axes; each roof bolt measurement includes readings for two orthogonal axes.

Propagation characteristics were determined by measuring signal and noise levels at selected points in the mine. An audio oscillator and power amplifier provided a nominal 10-watt transmit signal into a roof-bolt (line source) antenna. The receiver consisted of a battery operated preamplifier and tunable voltmeter. Two different receive antennas were evaluated; the first was a roof-bolt antenna of similar configuration to the transmit antenna, the second was a calibrated loop (magnetic dipole) antenna of the type normally used for field strength measurements. Vlf receive equipment was also transported via battery-powered mine scooter. Specific test equipment types and setups are described in appendix A.

At each receive point, signal strength readings were made for two orthogonal positions of the roof-bolt antenna and three orthogonal positions for the loop. The entire measurement sequence was then repeated for a second orientation of the transmit antenna. Measurements were conducted at three points spaced at intervals determined by the rate of signal attenuation. Spot noise measurements were made at each receive location and operating frequency. Uhf walkie talkies were used throughout the vlf tests for coordination.

### 2.3 TEST SITE

The Inland Steel Coal Mine is located in the Illinois No. 6 seam, approximately 10 miles north of Sesser, Illinois. The mine has a vertical shaft entry with 750 feet of overburden. It is a 9,000-ton-per-day continuous mine operation with belt haulage to a second vertical shaft where an elevator removes the coal to the surface. Transportation of men, equipment, and supplies to the various sections is done using dc battery operated rover carts. The mine is presently 8,000 feet north-south by 13,000 feet east-west with an ultimate size 3 miles north-south by 7.5 miles east-west. All tunnels and haulage ways are 14 feet wide by 7 to 8 feet high with pillars running 60 feet by 74 feet. Roof bolts are 6 to 9 feet in length and are placed on 4-foot centers.

A layout of the test area within the mine is shown in figure 2-1. The general measurement area extends along the no. 1 mains west for a 4,450-foot segment extending from the 2 left entry to the 8 right entry as indicated in the figure. The fixed transmitter location is shown between the 4 and 5 right entries at a point where 115-Vac power was available. Measurements taken along the 4,450-foot east-west dimension were in the same entry used for haulage of men and supplies. This tunnel also contained a 7200-Vac, 3-phase prime power cable suspended from the roof. A typical cross section of the mine in the measurement area is shown in figure 2-2.

Measurements of corner attenuation were made along tunnels or crosscuts at right angles to the main tunnel. Because of the importance of these measurements, expanded scale layouts of the corner geometry are shown in figures 2-3 and 2-4. All measurement points, including the points at right angles to the main tunnel were located in the inlet airways. This precaution was necessary to permit the use of nonapproved test equipment. As a result, measurements were not made near working faces of the mine. However, the test locations and geometries as shown in figures 2-2, 2-3, and 2-4 are representative of working areas within the mine so that the measured signal levels are generally valid.

### 2.4 PROPAGATION CHARACTERISTICS

The coal mine tests as described in paragraphs 2.2 and 2.3 have yielded a number of significant results at both uhf and vlf. These results are presented below in the form of graphs and tables showing transmission loss, field strength, or noise density as a function of the test parameters given in tables 2-1 and 2-2. The data are arranged for convenience in the engineering of communications systems as well as to demonstrate the radio propagation characteristics in mines.

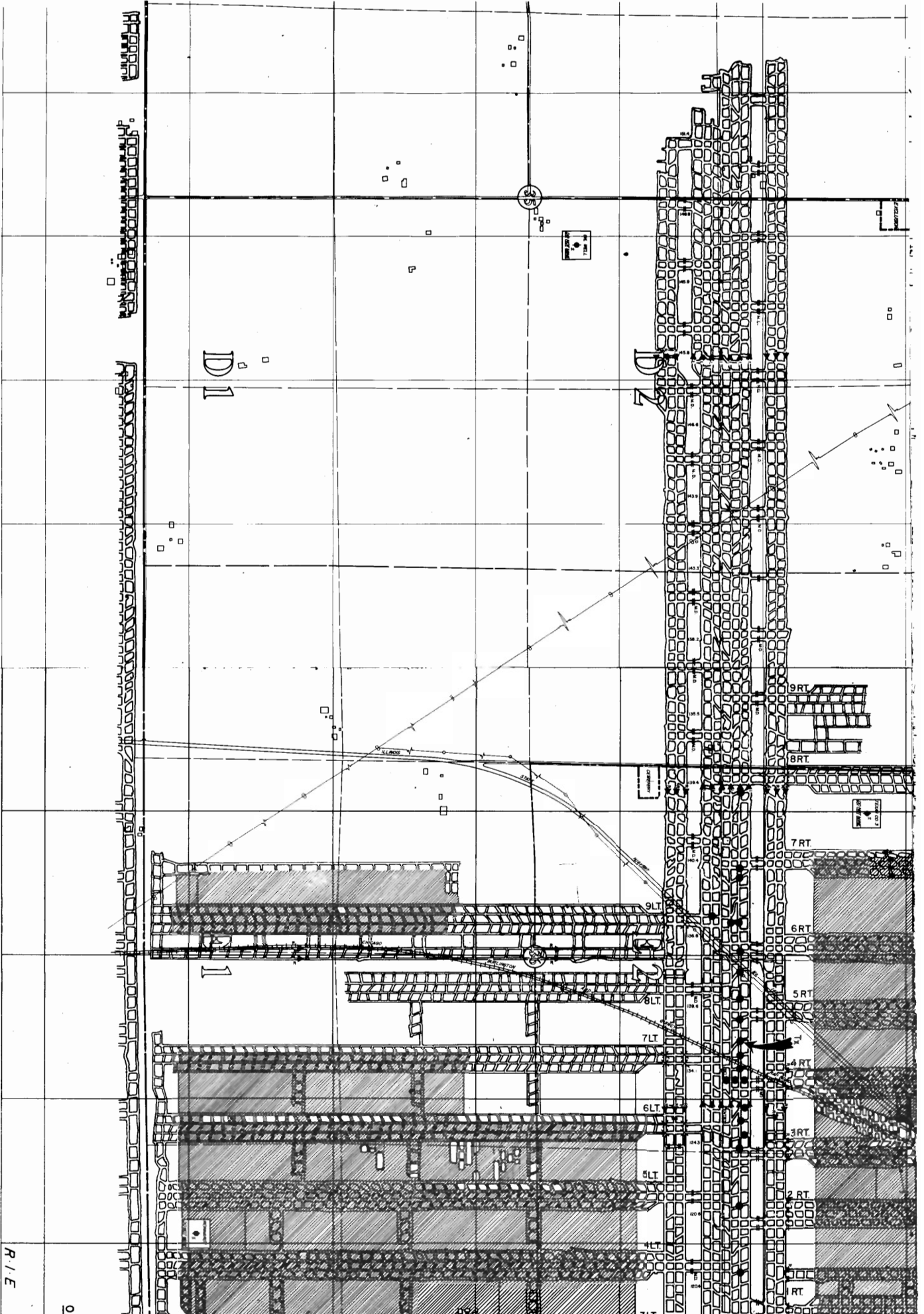

R/E

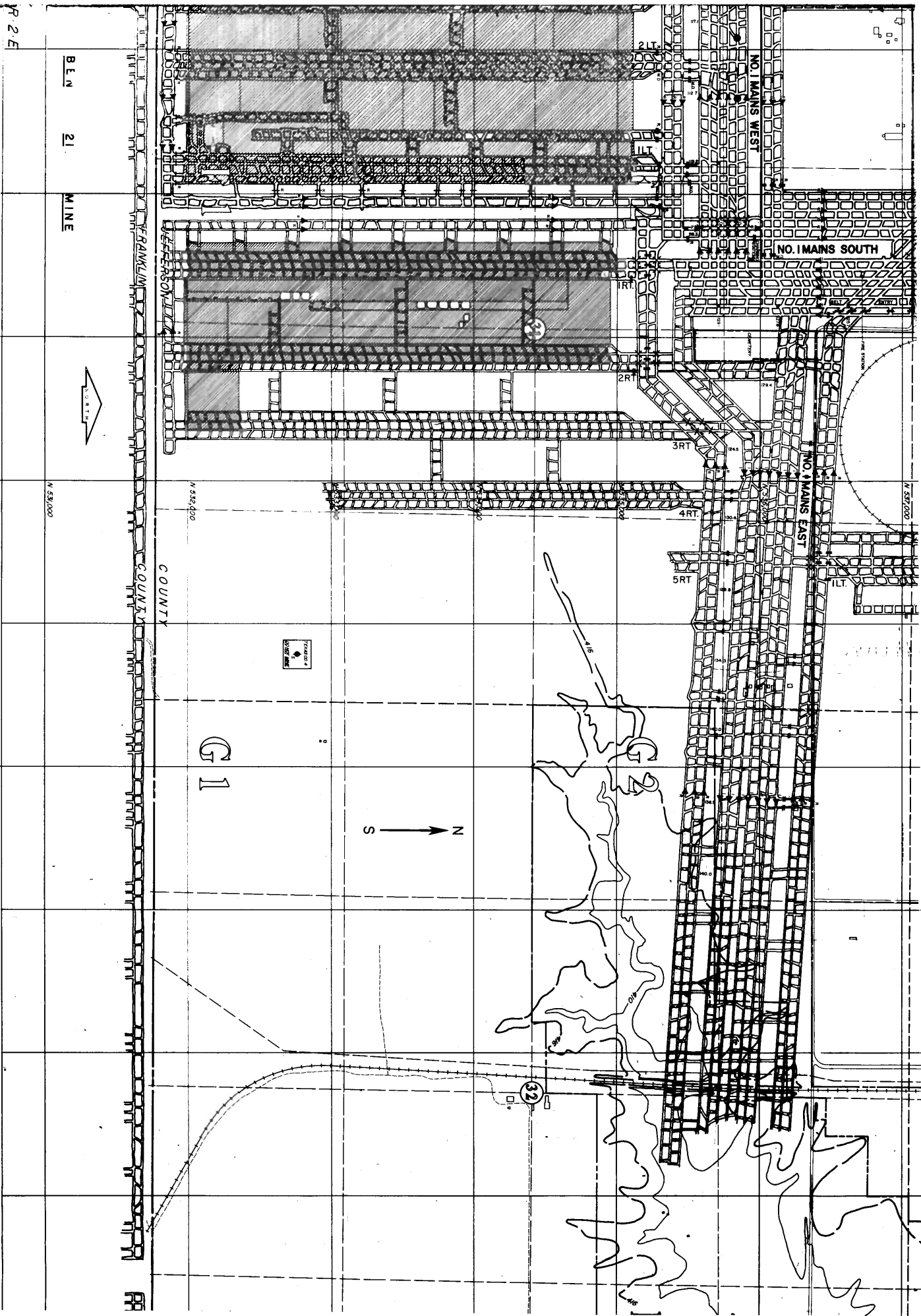
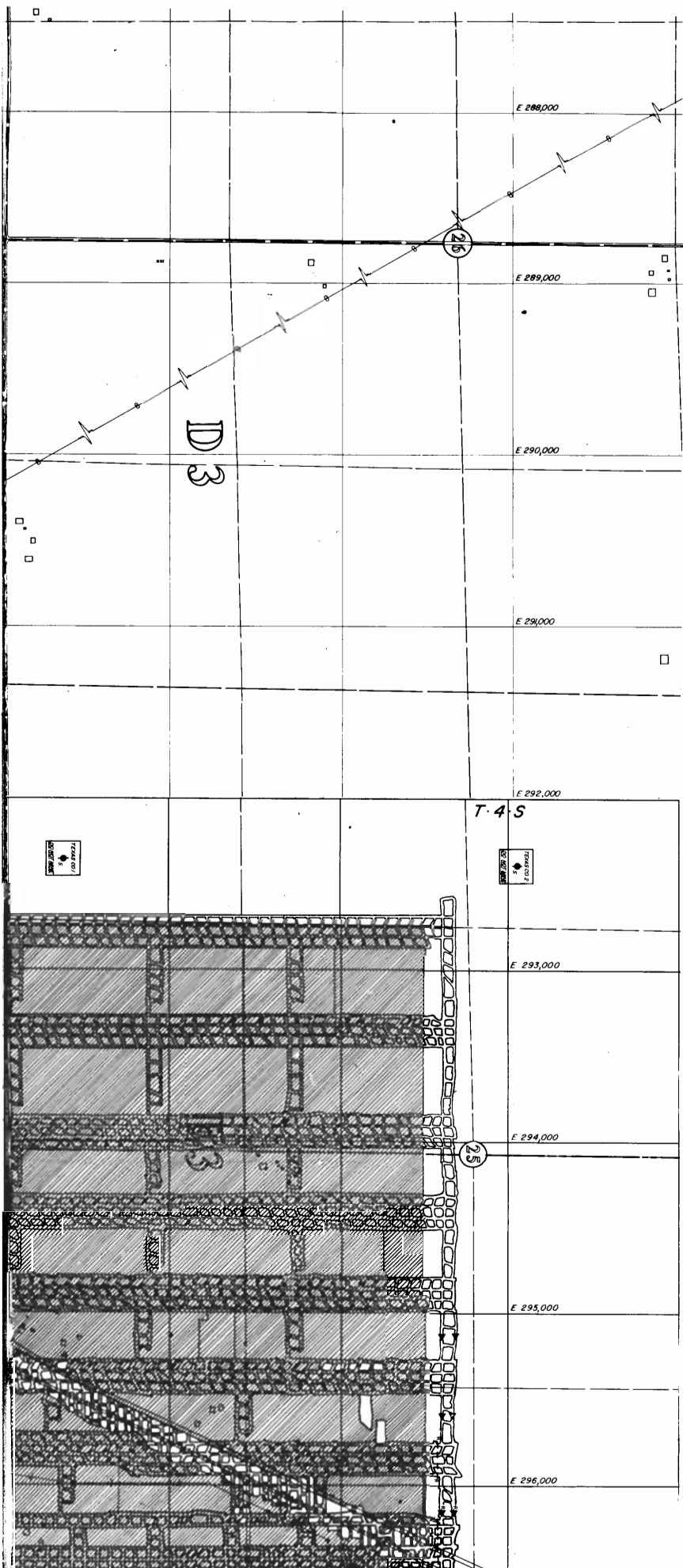
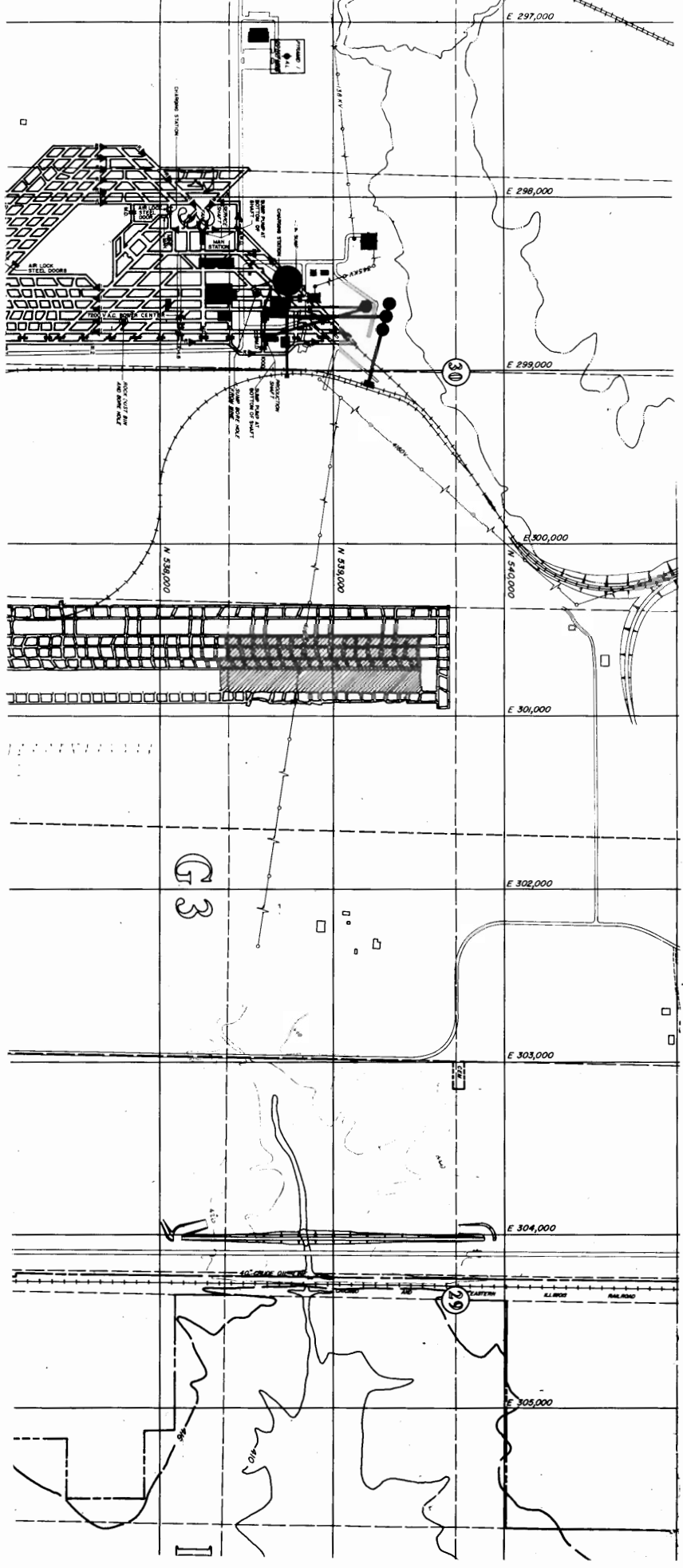

Figure 2-1. Coal Mine Test Site.



BALD  
ELK



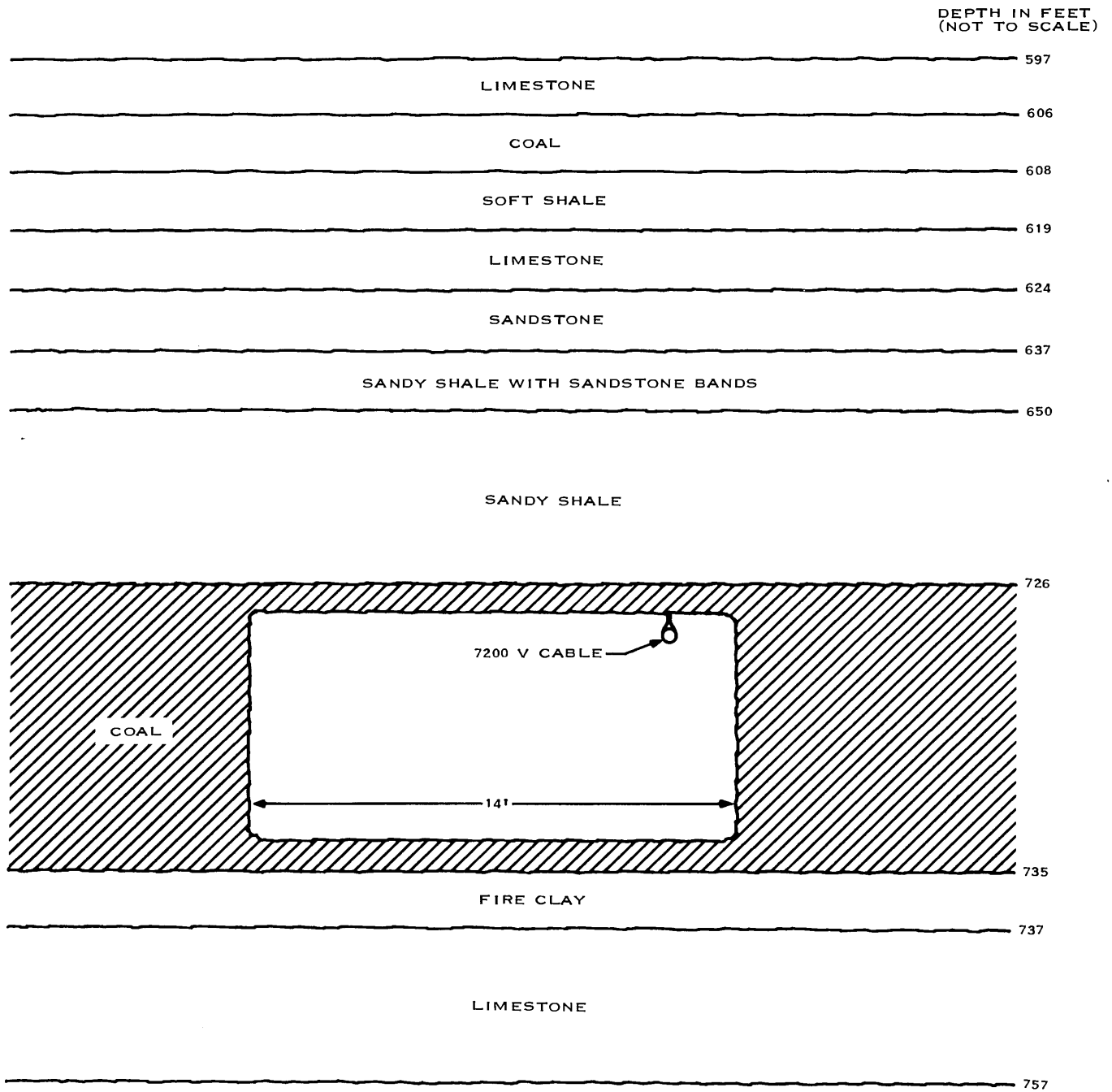

Figure 2-2. Tunnel Cross Section.

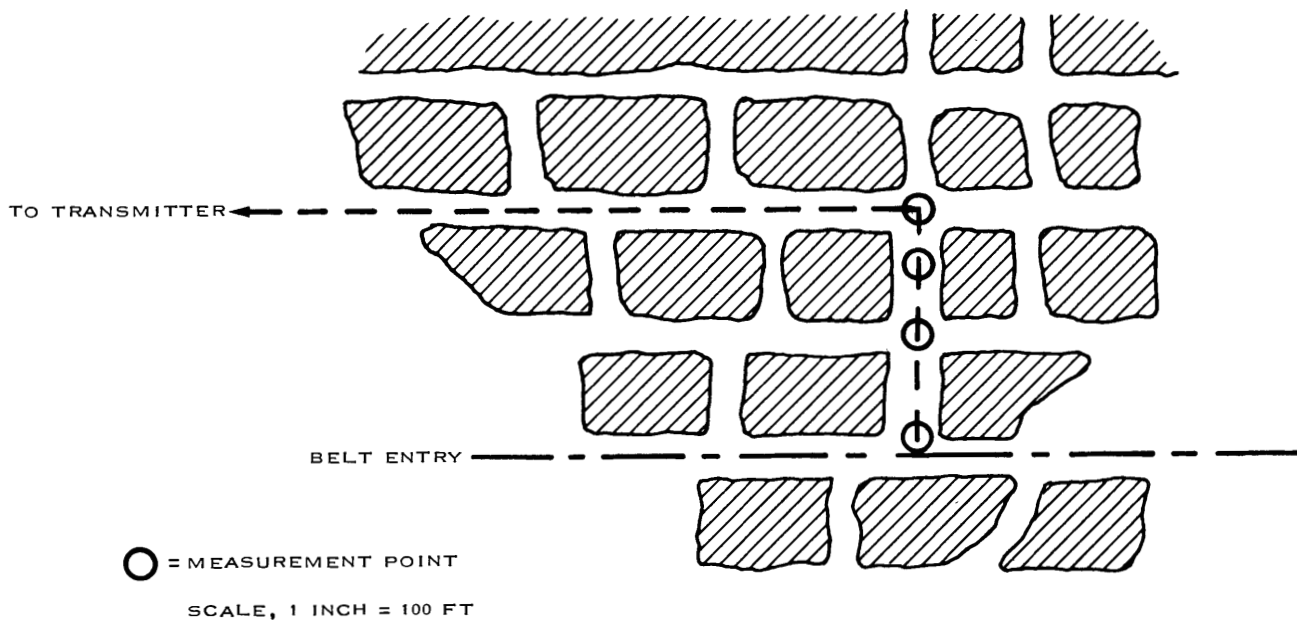

Figure 2-3. Corner No. 1 Layout.

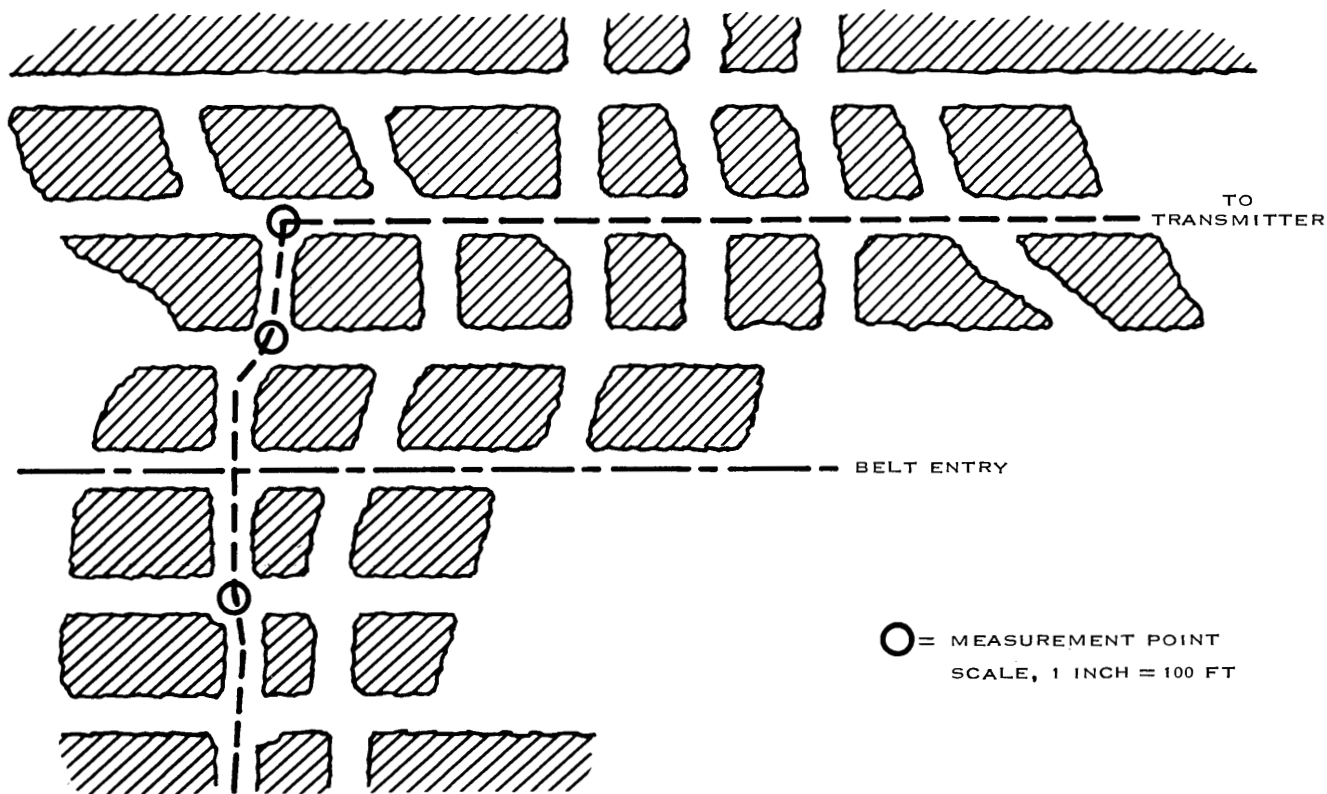

Figure 2-4. Corner No. 2 Layout.



## 2.4.1 UHF Propagation

### 2.4.1.1 Straight Tunnels

The observed signal attenuation along a straight tunnel is shown in figures 2-5, 2-6, and 2-7 for 200, 415, and 1000 MHz respectively. Attenuation is plotted as the power transfer ratio between isotropic antennas (basic transmission loss) for the indicated polarizations. Transmission loss may be combined directly with transmitter power, antenna gains, and rf cable losses to determine the received signal for any candidate uhf system. In terms of transmission loss, a pair of 1-watt uhf walkie-talkies has a range of 143 to 146 dB.

It should be noted that the uhf attenuation curves are the result of an "eyeball fit" to the observed data. As with any uhf field measurements, individual points show some deviation from the curve owing to small-scale differences at each measurement location. In most cases, scatter from the established line is less than 3 to 4 dB. In a few cases, deviation in excess of 5 dB is observed. The transmission loss measurement accuracy is estimated to be  $\pm 2.5$  dB.

Significant propagation characteristics apparent from figures 2-5, 2-6, and 2-7 are as follows:

- a. Attenuation (in dB) increases nearly linearly with increasing distance.
- b. Horizontal polarization produces significantly lower transmission loss at a given distance than does vertical polarization. Cross polarization produces a loss intermediate between horizontal and vertical.
- c. Transmission loss decreases significantly at a given distance as the frequency is increased.

Linear attenuation (in dB) versus distance is a characteristic of waveguide propagation; the tunnel geometry (figure 2-2) also suggests a guided mode of propagation. From the slope of attenuation curves, attenuation rates have been determined as shown in table 2-3. The values for 200 MHz are considered to be very approximate because they are based on a small number of data points. For comparison, Farmer and Shepherd<sup>1\*</sup> report a value of 12 dB/100 ft at 160 MHz for straight passageways underground and in buildings. Crary<sup>2</sup> reports calculations for a circular waveguide tunnel approximation of 5.2 to 8.0 dB/meter (158 to 254 dB/100 ft) at 160 MHz, 0.6 to 1.5 dB/meter (18.3 to 45.5 dB/100 ft) at 500 MHz and 0.1 to 0.2 dB/meter (3.05 to 6.1 dB/100 ft) at 1 GHz.

Table 2-3. Observed Attenuation Rates for a Straight Coal Mine Tunnel.

| FREQUENCY | POLARIZATION                        |             |              |
|-----------|-------------------------------------|-------------|--------------|
|           | VERTICAL                            | *CROSS      | HORIZONTAL   |
| 200 MHz   | $\approx 25\text{dB}/100\text{ ft}$ | 15dB/100 ft | ---          |
| 415 MHz   | 6dB/100 ft                          | 6dB/100 ft  | 6dB/100 ft   |
| 1000 MHz  | 4dB/100 ft                          | 3dB/100 ft  | 2.5dB/100 ft |

\*Vertical transmit, horizontal receive.

\*See references at end of this section in paragraph 2.6.

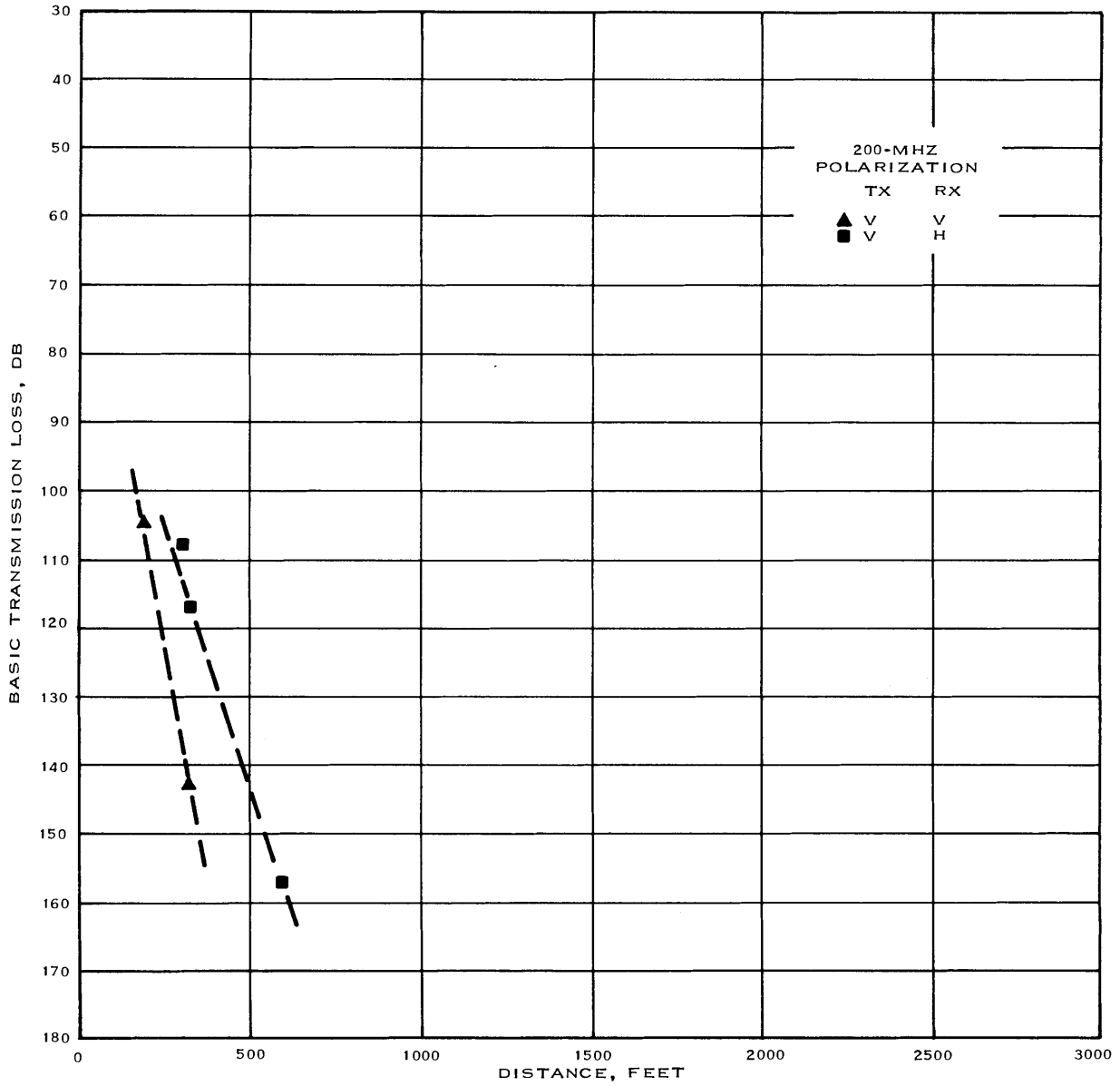

Figure 2-5. Observed 200-MHz Transmission Loss for a Straight Coal Mine Tunnel.

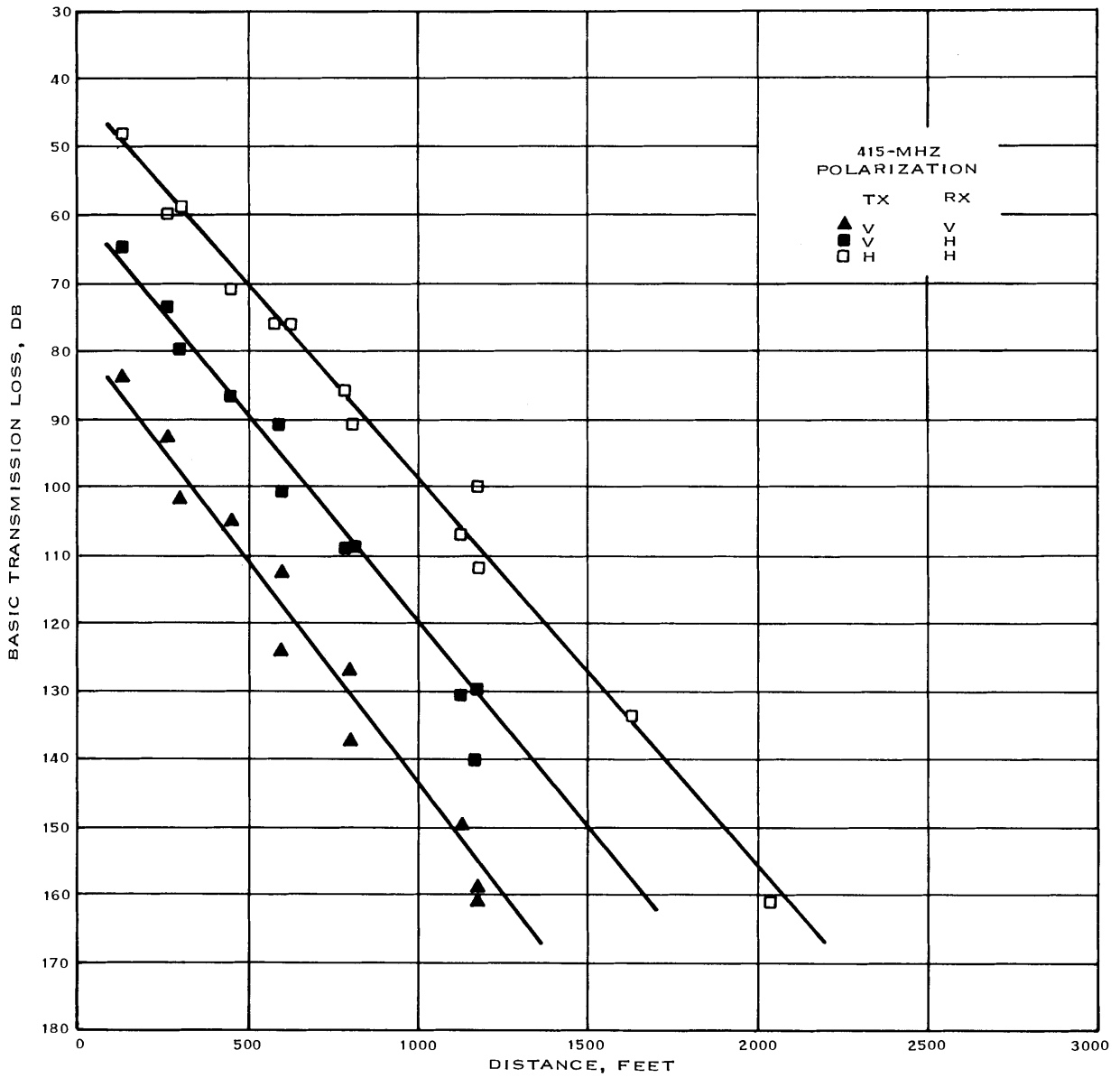

Figure 2-6. Observed 415-MHz Transmission Loss for a Straight Coal Mine Tunnel.

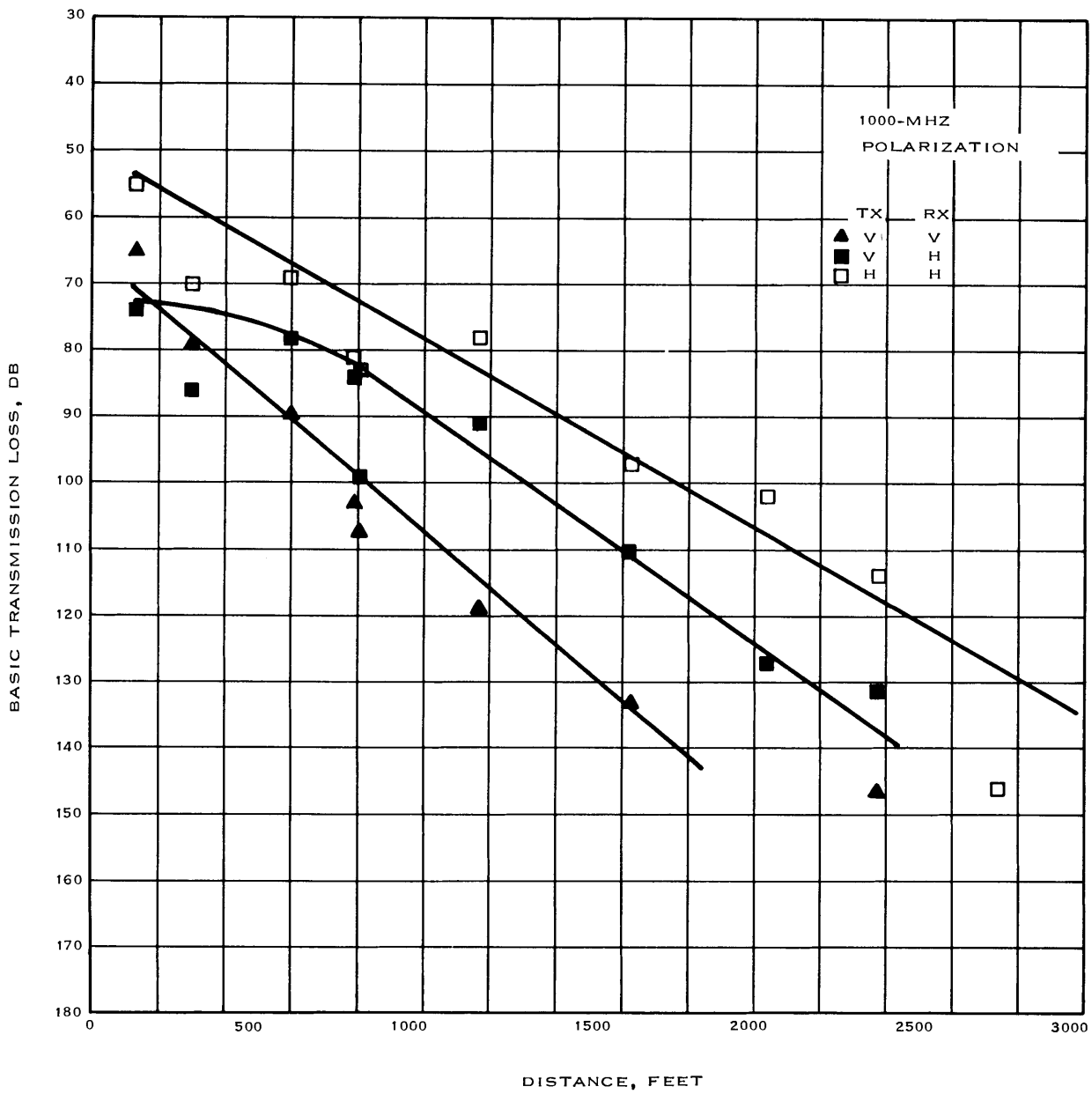

Figure 2-7. Observed 1000-MHz Transmission Loss for a Straight Coal Mine Tunnel.

The considerable difference between vertical and horizontal polarization is an interesting result. At 400 MHz, the observed signal attenuation for horizontal polarization is typically 40 dB less than that for vertical. The cross-polarized (vertical transmit, horizontal receive) attenuation is 22 dB less than vertical. At 200 MHz, no horizontal measurements were made, however the cross-polarized attenuation is on the order of 25 dB less than vertical, while at 1 GHz horizontal attenuation averages 30 dB less than vertical, and cross-polarized attenuation averages 17 dB less than vertical. A further result, seen at both 200 and 415 MHz is that this polarization behavior is observed within 130 feet of the transmitter.

As the frequency is increased, propagation along the guide should become less affected by the presence of dissipative walls because of the method of launching signals from an antenna completely internal to the tunnel. However, as the frequency is increased without limit, signal attenuation will become practically infinite when a line-of-sight path along the tunnel does not exist. Evidence of reduced wall effects is seen in comparing attenuation values for the three frequencies. As frequency is increased, the transmission loss decreases, the attenuation rate decreases, and the difference between horizontal and vertical polarization also decreases. Particularly evident at 1 GHz at the 130-ft distance is the fact that the observed vertical signal strength is only 10 dB below horizontal, while the cross-polarized value is 20 dB below horizontal. Thus, the observations are approaching the more typical case for short distances at uhf where horizontal and vertical attenuations are approximately equal and the cross-polarized value is considerably weaker. It is apparent from the observed data that the optimum frequency for the measured tunnel lies above 1 GHz.

In an attempt to determine what effect, if any, the 7200-Vac power cable had upon observed transmission loss, measurements were made across the tunnel at each distance increment. Referring to figure 2-2, measurement points were located in the center of the tunnel, directly under the cable, and away from the cable within three feet of the opposite wall. Table 2-4 shows the average signal attenuation relative to that observed at the tunnel center position. These results indicate that the lowest transmission loss occurs at the tunnel center with modest increases in attenuation near the tunnel walls. At 415 MHz there appears to be no appreciable field distortion caused by the power cable, while at 1 GHz signal attenuation is slightly larger under the cable.

Table 2-4. Observed Attenuation At Tunnel Edges Relative To Center.

| FREQUENCY | HORIZONTAL UNDER CABLE | POLARIZATION AWAY FROM CABLE | VERTICAL UNDER CABLE | POLARIZATION AWAY FROM CABLE |
|-----------|------------------------|------------------------------|----------------------|------------------------------|
| 200 MHz   | ---                    | ---                          | ---                  | ---                          |
| 415 MHz   | 5 dB                   | 6.5 dB                       | 3.5 dB               | 4.0 dB                       |
| 1000 MHz  | 2 dB                   | 0.5 dB                       | 2.0 dB               | 0.5 dB                       |

#### 2.4.1.2 Corners

With the straight tunnel measurements as a reference, data were also obtained around corners for the two situations shown in figures 2-3 and 2-4. Observed corner attenuation is shown in figures 2-8, 2-9, and 2-10 for 200, 415, and 1000 MHz, respectively. Corner attenuation is plotted in dB relative to the horizontally polarized signal level observed in the center of the main tunnel. The same statements regarding curve fitting and measurement accuracy that pertain to the straight tunnel data also pertain to corner data.

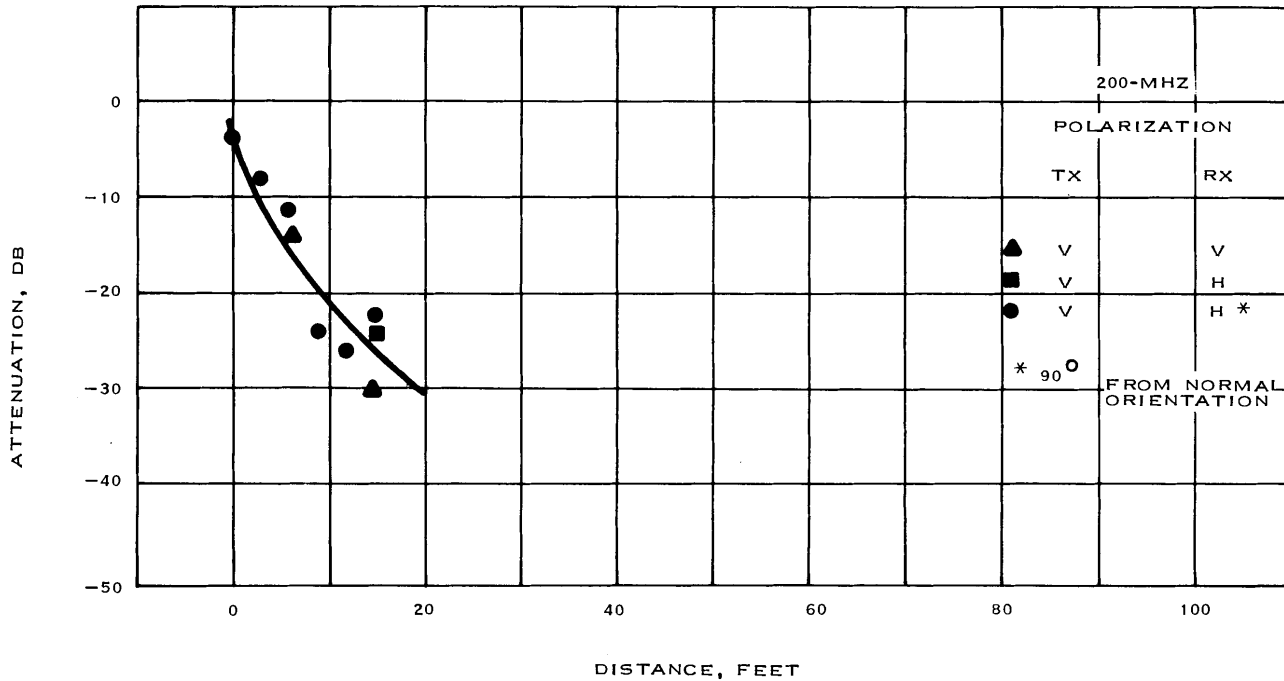

Figure 2-8. 200-MHz Corner Attenuation for Coal Mine Tunnel.

Significant propagation characteristics apparent from figures 2-8, 2-9, and 2-10 are as follows:

- Signal attenuation immediately around a corner is considerable at all three frequencies.
- There appears to be complete depolarization of signals around the corner.

Because of the high attenuation of a single corner, propagation around multiple corners is expected to be even more severely attenuated. Consequently, the signal existing at any point can be reasonably assumed to have followed the path including the least number of corners. The transmission loss at any point along a cross-tunnel can then be estimated by adding the attenuation from the appropriate curve in figure 2-8, 2-9, or 2-10 to the transmission loss corresponding to the distance along the main tunnel from the transmitter to the corner of the cross-tunnel. The corner attenuation curves are relative to the horizontal field at the center of the main tunnel. Therefore, if transmit polarization is horizontal, the horizontal curve from figure 2-5, 2-6, or 2-7 is used; if transmit polarization is vertical, the cross-polarization curve is used. (Note that receive polarization is unimportant because of depolarization around the corner.)

For example, if the receive point lies 750 ft along the main tunnel and 60 ft along a cross-tunnel, the transmission loss at 415 MHz is 147 dB when horizontal transmit polarization is used and 166 dB when vertical transmit polarization is used.

As a check of the measured data, the walkie talkies were used to determine communications range along the main tunnel and several cross-tunnels. At three points where the communication signal became marginal, the transmission losses were determined to be 148, 150, and 136 dB using the appropriate 415-MHz curves. These losses compare favorably with the 143 to 146 dB range of the 1-watt walkie talkies.

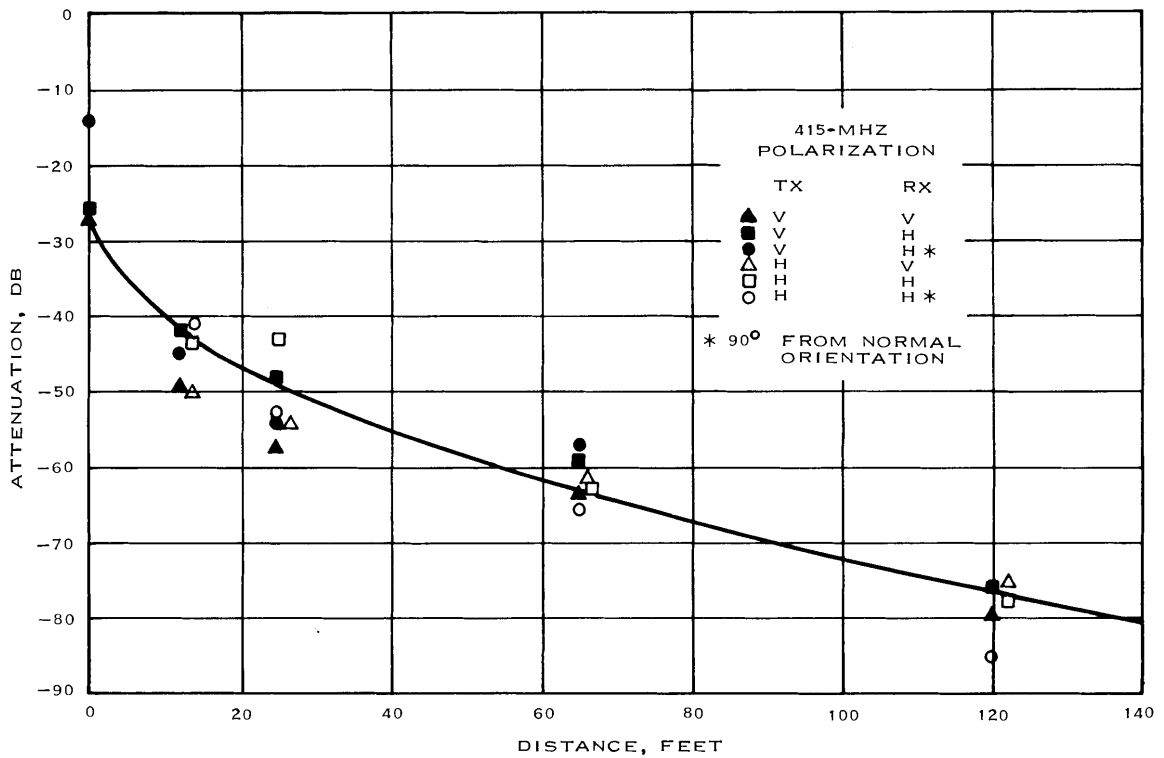

Figure 2-9. 415-MHz Corner Attenuation for Coal Mine Tunnel.

### 2.4.1.3 Corner Reflector

Because of the severe attenuation experienced around corners, measurements were made to determine the amount of improvement gained through the use of corner reflectors to divert additional energy along the cross-tunnels. At 415 MHz, the reflector consisted of two corner reflector antennas connected back-to-back electrically and physically. Design parameters and a picture of the antenna assembly (configured for vertical polarization) are provided in appendix A. At 1 GHz, a square aluminum plate of  $6\lambda^2$  area was used.

Observed corner reflector gain is shown in table 2-5 for 415 and 1000 MHz. No tests were performed at 200 MHz. Reflector gain is defined as the difference between signal levels observed before and after the reflector is set in position. The reference point for signal measurement is 65 feet along the cross-tunnel from the corner of the main tunnel. In each of the cases tested, significant reflector gain was noted.

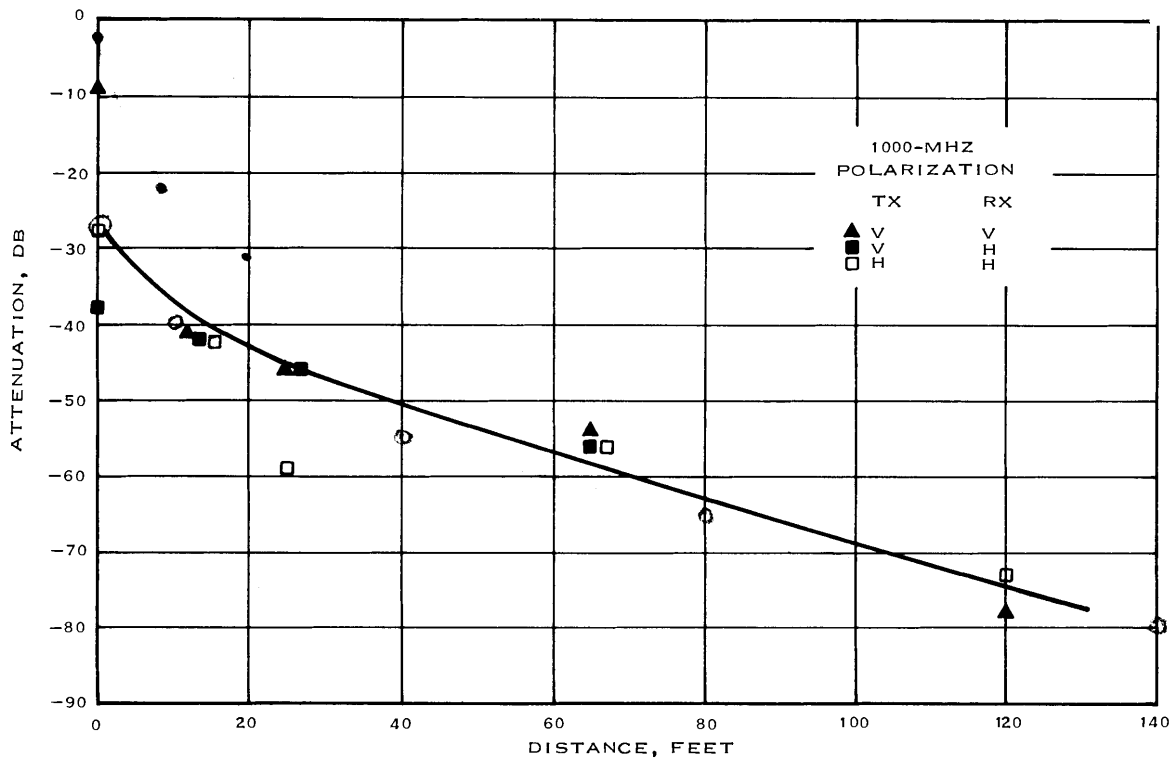

Figure 2-10. 1000-MHz Corner Attenuation for Coal Mine Tunnel.

Table 2-5. Observed Corner Reflector Gain.

| FREQUENCY                                 | TRANSMITTER | POLARIZATION REFLECTOR | RECEIVER | GAIN  |
|---|-------------|------------------------|----------|-------|
| 415 MHz                                   | H           | H                      | H        | 31 dB |
|   | H           | H                      | V        | 17 dB |
|   | V           | V                      | H        | 18 dB |
|   | V           | V                      | V        | 19 dB |
| 1 GHz                                     | H           | *                      | H        | 25 dB |
|   | V           | *                      | H        | 20 dB |
|   | V           | *                      | V        | 23 dB |
| *Flat plate reflects either polarization. |             |                        |          |       |



Two trends appear in the measurements of corner reflector that require additional data points for confirmation.

The first trend is away from the depolarized field observed without the corner reflector toward a dominant horizontal field, as observed in the main tunnel. This effect can be seen in table 2-5 in comparing the 31-dB gain value to the 17-dB value. Unfortunately, no corresponding data was taken at 1 GHz for comparison to the 25-dB value. With a vertical transmitter, however, the field appears to remain depolarized (18 vs 19 dB, 20 vs 23 dB).

The second trend, observed at 1 GHz, indicates a much lower attenuation rate along the cross-tunnel when a corner reflector is used. The observed attenuation rate more closely matches the 2- to 3-dB/100-ft rate observed in the main tunnel rather than the 30-dB/100-ft rate shown in figure 2-10. No data is available at 415 MHz for comparison.

#### 2.4.1.4 UHF Noise

Spot noise measurements were made at each receiving point for horizontal and vertical polarization. In each case the external noise level was sufficiently below internal receiver noise to be undetectable. This type of noise survey is very superficial; however, the most probable source of uhf noise in the mine is from machine and power line generated rfi. Measurements made in the vicinity of heavy, battery-operated equipment and the 7200-Vac power line produced no observable noise. Threshold noise sensitivity for the uhf field meter is listed in table 2-6.

Table 2-6. UHF Noise Sensitivity Threshold.

| FREQUENCY | NOISE THRESHOLD SENSITIVITY |
|-----------|-----------------------------|
| 200 MHz   | -166 dBm/Hz                 |
| 415 MHz   | -166 dBm/Hz                 |
| 1000 MHz  | -157 dBm/Hz                 |

#### 2.4.2 Experimental VLF Propagation

##### 2.4.2.1 Roof Bolts

Observed signal attenuation for intramine roof-bolt-to-roof-bolt antennas is shown in figures 2-11 and 2-12 plotted against frequency and in figure 2-13 plotted against distance. Attenuation is plotted as the power transfer ratio between the roof-bolt antenna terminals. Transmission loss may be added directly to transmitter power to determine the received signal level (available power into matched load). The vlf attenuation curves are straight line segments connecting related data points. Transmission loss measurement accuracy is estimated to be  $\pm 2$  dB.

Because of emphasis on the uhf measurements, only three field points were measured at vlf. During vlf testing, the antennas were established in cross-tunnels just north of the main tunnel (figure 2-1) so that no line-of-sight path existed between receiver and transmitter. Walkie-talkie communication between the field points was possible; however, signals were typically weak.

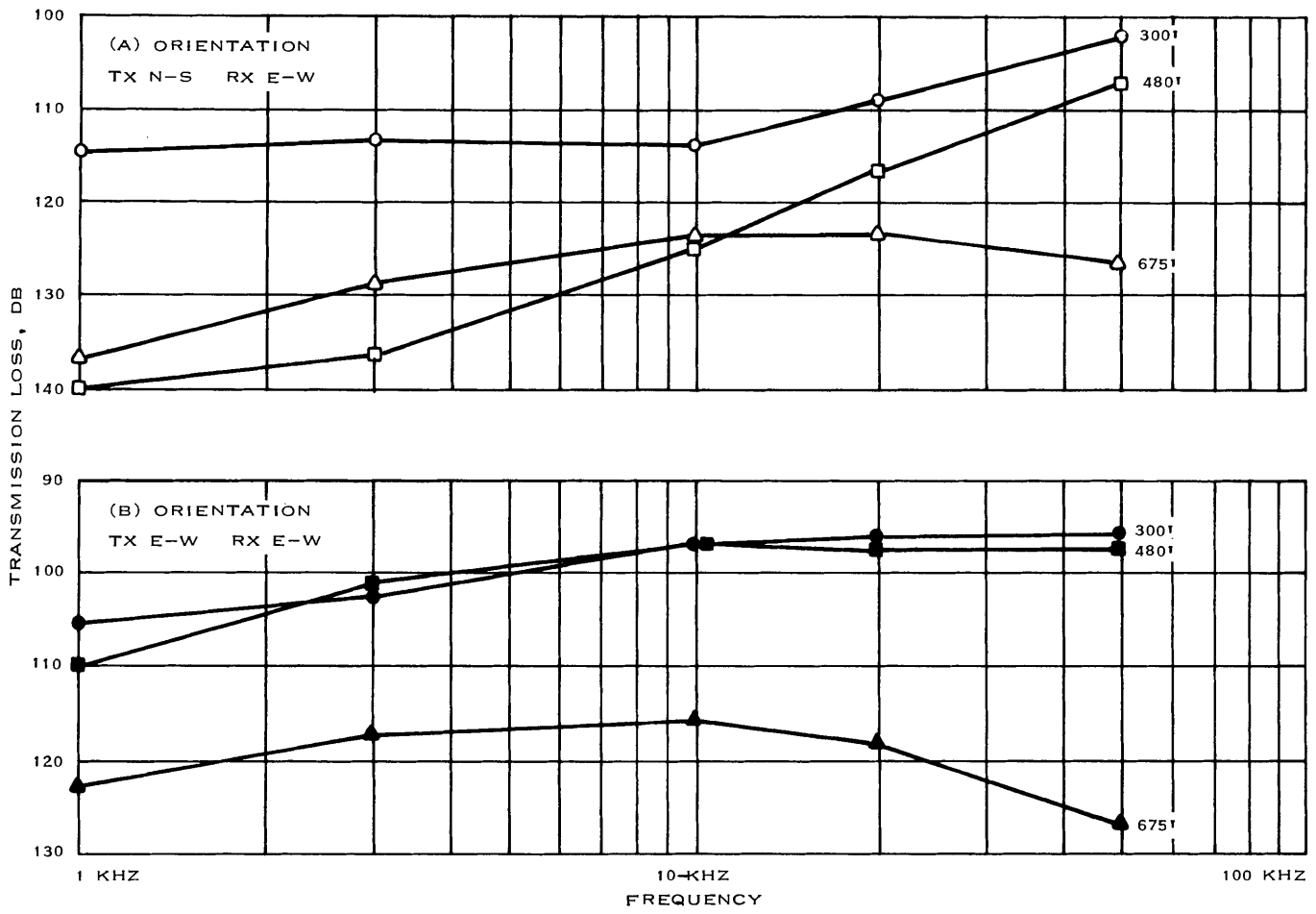

Figure 2-11. Observed Transmission Loss for Roof-Bolt Antennas in Coal Mine.

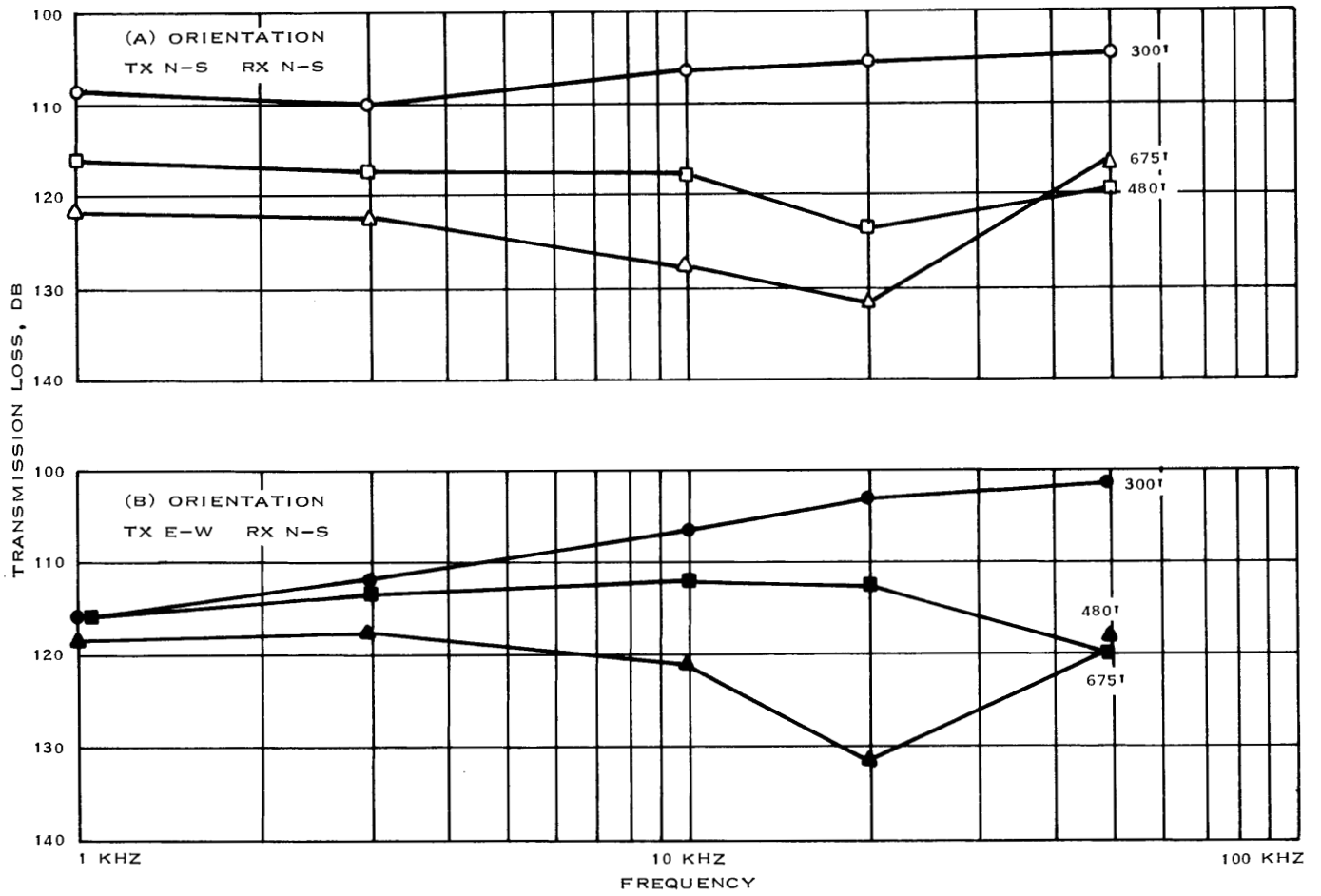

Figure 2-12. Observed Transmission Loss for Roof-Bolt Antennas in Coal Mine.

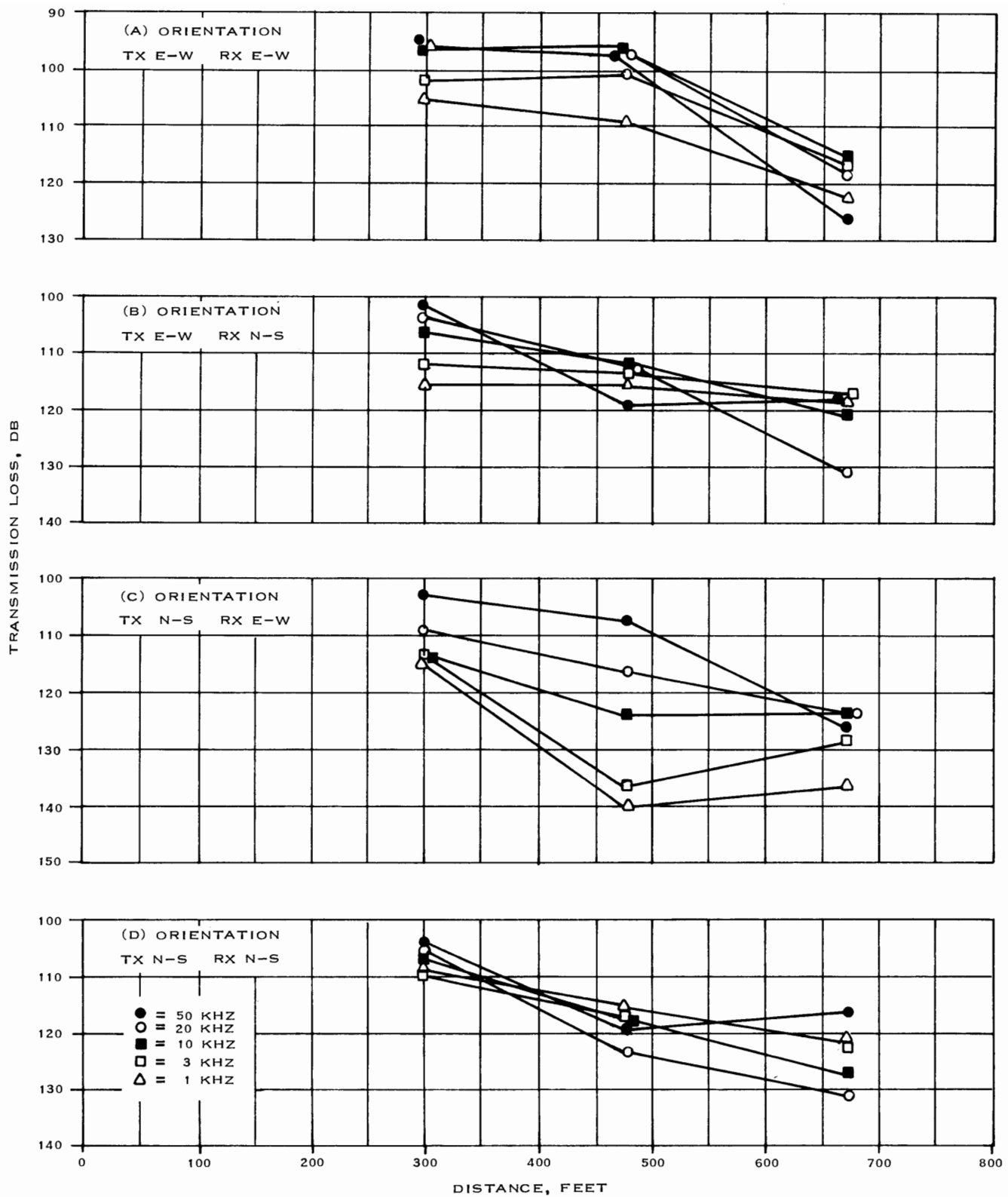

Figure 2-13. Observed Transmission Loss for Roof-Bolt Antennas in Coal Mine.

Tests were conducted for two orientations of the receive and transmit antennas for a total of four configurations. An antenna was established by clamping a pair of test leads to two roof-bolt heads separated by 52 feet. Each roof bolt was cleared of accumulated rock dust and rust to ensure good electrical connection. The north-south antenna orientation resulted in the antenna leads running perpendicular to the main east-west tunnel. The east-west orientation resulted in antenna leads running parallel to the main tunnel. A roof-bolt spacing of 52 feet was used throughout the tests. The impedance of the antennas was 100 to 120 ohms, resistive, over the 1- to 50-kHz measurement range.

Significant propagation characteristics apparent from figures 2-11, 2-12, and 2-13 are as follows:

- a. Minimum transmission loss occurs for the east/west-to-east/west antenna combination indicating maximum coupling off the ends of the antennas.
- b. Transmission loss is relatively flat versus frequency.
- c. The attenuation rate is approximately 5 dB/100 ft averaged over all frequencies and antenna orientations.

The available measurements do not fully characterize the propagation behavior. In particular, measurements over a greater range of distance, frequency and roof-bolt spacing are desirable. However, the range of a roof-bolt voice radio system can be estimated from measured data. Assuming a 25-watt transmitter, 10-dB noise figure receiver, 10-dB external noise, and a required voice  $S/N_0$  of 47 dB-Hz, the system has a range of 158 dB. Further assuming that the curves of figure 2-13 extrapolate at 5 dB/100 ft, 158-dB transmission loss then occurs at a distance of 1,200 to 1,400 feet, depending on antenna orientation.

#### 2.4.2.2 Roof-Bolt Noise

Spot noise measurements were made at each receiving point for both orientations of the receiver roof-bolt antenna. In each case, the external noise level was below or on the order of the receiver internal noise in the 5- to 50-kHz region. Receiver noise threshold sensitivity was approximately -150 dBm/Hz. This result suggests excess noise was 24 dB or less over the 5- to 50-kHz region.

The spot type of noise survey is superficial, at best, particularly since the measurement area was not close to a working face. However, measurements were taken in the vicinity of the 7200-Vac power cable. Below 5 kHz, the harmonic levels were sufficient to be a potential source of interference to a voice bandwidth communication system; however, specific levels were not recorded.

#### 2.4.2.3 Loops

Observed field strength for intramine roof-bolt-to-loop antennas is shown in figures 2-14 and 2-15 plotted against frequency and in figure 2-16 plotted against distance. Field strength is shown as the magnetic field intensity in dB/ $\mu$ A/m. This quantity is chosen rather than transmission loss because system performance analysis with loop antenna parameters as a variable is more convenient when the incident field strength is known. Also, direct comparison with noise data that is given in units of dB/ $\mu$ A/m/ $\sqrt{\text{Hz}}$  is possible without first correcting for the differences between the loop used for signal measurements and the loop used for noise measurement. The field strength curves are straight line segments connecting related data points. Field strength measurement accuracy is estimated at  $\pm 2$  dB.

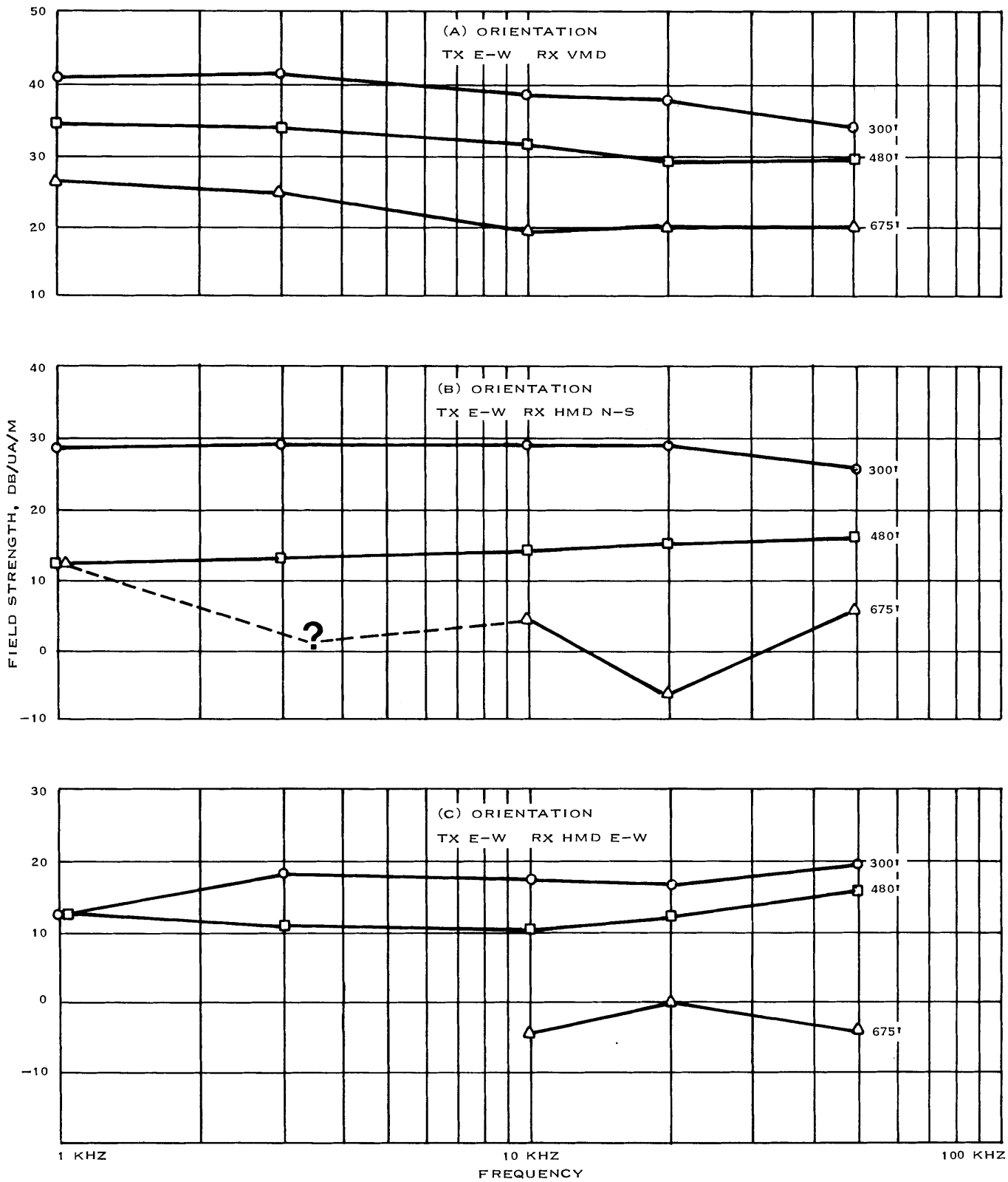

Figure 2-14. Observed Field Strength for Roof-Bolt-to-Loop Antennas in Coal Mine.

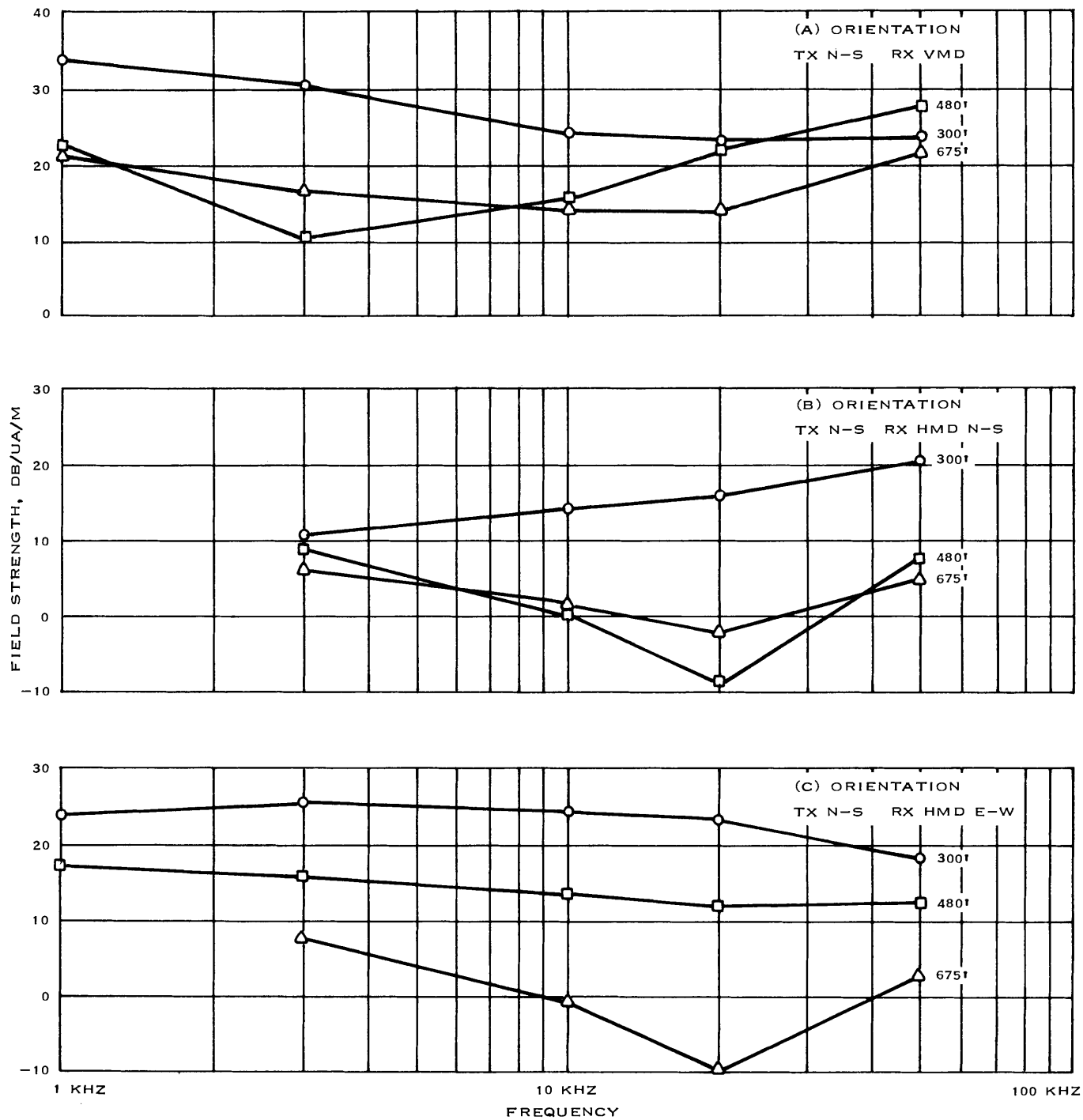

Figure 2-15. Observed Field Strength for Roof-Bolt-to-Loop Antennas in Coal Mine.

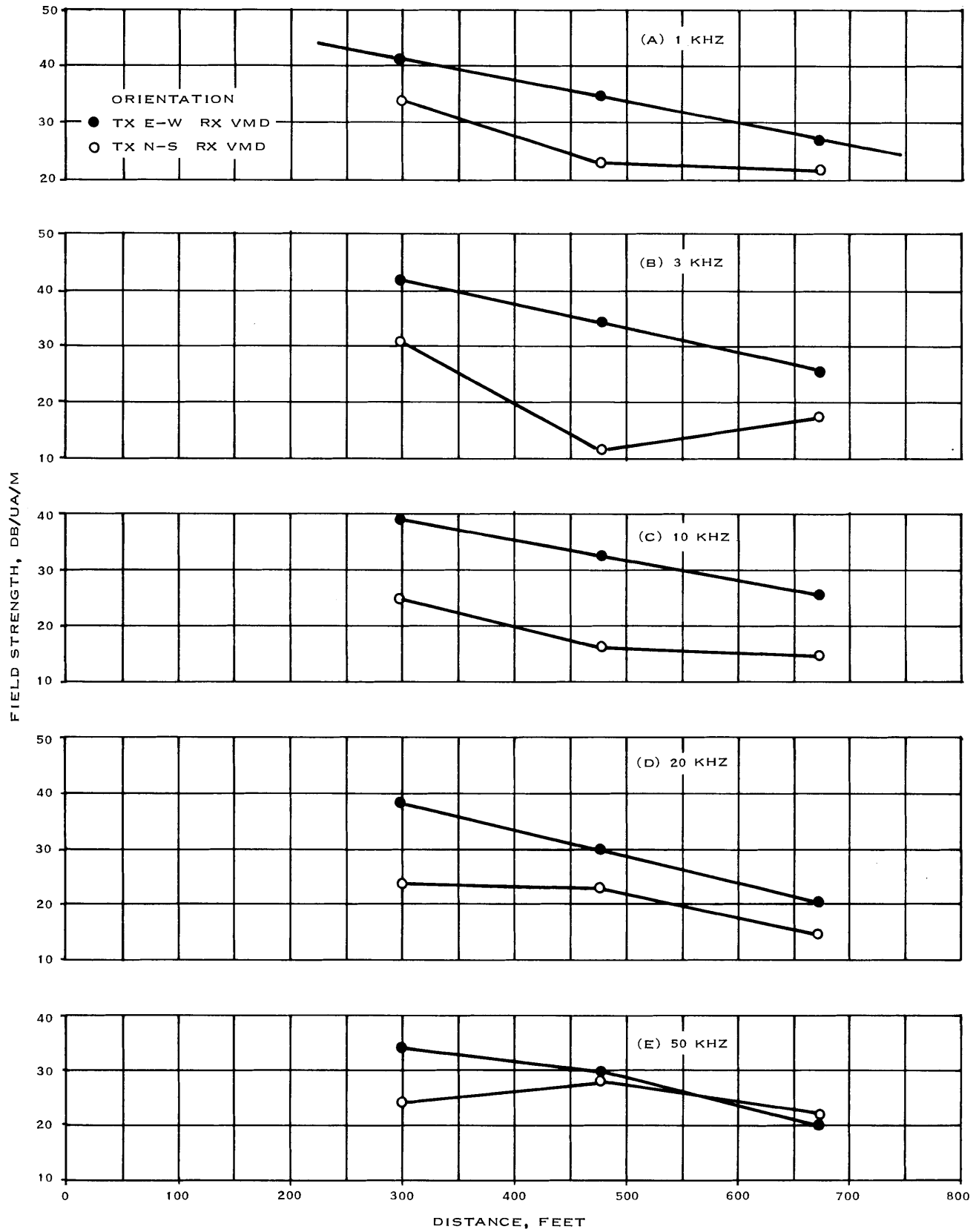

Figure 2-16. Observed Field Strength for Roof-Bolt-to-Loop Antennas in Coal Mines.



During vlf testing, antennas were established in cross-tunnels just north of the main tunnel (figure 2-1), so that no line-of-sight path existed between receiver and transmitter. Walkie-talkie communication between the field points was possible; however, signals were typically weak.

Tests were conducted for three orientations of the receiver loop and two orientations of the transmit roof-bolt antenna for a total of six configurations. The north-south and east-west orientations of the roof-bolt antenna are described in the above paragraph on roof bolts (paragraph 2.4.2.1).

The three orientations of the receive loop are given with respect to the magnetic dipole axis, that is, vertical (VMD); horizontal east-west (HMD E-W); horizontal north-south (HMD N-S). The relative configurations of the antennas can be seen with the aid of figure 2-1.

Significant propagation characteristics apparent from figures 2-14, 2-15, and 2-16 are as follows:

- a. Maximum field strength occurs for the E-W roof bolt-to-VMD configuration.
- b. Field strength is relatively flat versus frequency.
- c. The attenuation rate is approximately 4 dB/100 ft averaged over all frequencies and antenna orientations.

The available measurements do not fully characterize the propagation behavior. In particular, measurements over a greater range of distance, frequency, and roof-bolt spacing are desirable. However, the range of a roof-bolt-to-loop-voice bandwidth radio system can be estimated from measured data. Assuming a 25-watt transmitter, 10-dB noise figure receiver, 10-dB externally caused antenna noise, loop antenna similar to those used for field measurements, and a required voice  $S/N_0$  of 47 dB-Hz, the required field strength is -14 dB/ $\mu$ A/m at 50 kHz and +20 dB/ $\mu$ A/m at 1 kHz. Further assuming that the curves of figure 2-16 extrapolate at 4 dB/100 ft, the minimum useful field strengths are reached at approximately 1,500 feet at 50 kHz and 800 feet at 1 kHz when the loop is oriented as a VMD.

#### 2.4.2.4 Loop Noise

Spot noise measurements were made at each receiving point for three receive loop orientations. In each case the external noise level was below internal receiver noise, across the 7- to 50-kHz region. Receiver noise sensitivity was approximately -150 dBm/Hz, equivalent to an incident field strength of -43 dB/ $\mu$ A/m/ $\sqrt{\text{Hz}}$  at 50 kHz, and increasing at 6 dB/octave below 50 kHz. Sensitivity from 20 to 50 kHz was adequate only for the detection of noise levels near the maximum to be expected according to results obtained at WVU.<sup>3</sup>

The spot type of noise survey is superficial, at best, particularly since the measurement area was not close to a working face. However, measurements were taken in the vicinity of the 7200-Vac power cable. Below 7 kHz, power line harmonics were detected. Below 2 kHz, harmonic levels were sufficient to be a potential source of interference to a voice bandwidth communication system; however, specific levels were not recorded.

#### 2.4.3 Summary and Conclusion

A series of radio measurements were conducted in a working coal mine to determine uhf and vlf propagation characteristics. Measurements included the effects of frequency, polarization, antenna type, and distance. The uhf tests included propagation along straight tunnels and around corners, and a comparison of results using passive reflectors at tunnel corners. The vlf tests evaluated the performance of roof-bolt and loop antennas. A number of results were obtained that have practical significance in the definition, design, and implementation of radio communications systems in mines.

#### 2.4.3.1 UHF

At uhf a strong dependence of signal attenuation on frequency and polarization was noted. Along a straight tunnel, attenuation rates varied from 15 to 25 dB/100 ft at 200 MHz to 2.5 to 4 dB/100 ft at 1 GHz. Minimum attenuation is expected at frequencies above 1 GHz. Horizontal polarization was found to yield significantly improved results compared to vertical or cross polarization. The attenuation of horizontally polarized signals averaged 40 dB less than vertically polarized signals at 415 MHz and 30 dB less at 1 GHz. Considerable attenuation was observed in radio signals propagated around tunnel corners. Signal attenuation was approximately 45 dB at a point 20 feet past the corner at 415 and 1000 MHz. The rate of attenuation past 20 feet averaged 30 dB/100 ft as opposed to the 3 to 6 dB/100 ft rate observed in the main tunnel at 415 and 1000 MHz. Complete signal depolarization was noted along the cross-tunnel as opposed to the strong horizontal polarization observed in the main tunnel. The use of a corner reflector raised the signal level from 20 to 30 dB at a point 65 feet past the corner. At 1 GHz, the reflector appeared to lower the attenuation rate along the cross-tunnel, resulting in even greater effective gains further away from the corner.

#### 2.4.3.2 VLF

At vlf, minimum attenuation between two roof-bolt antennas occurred in the end-to-end configuration, but other combinations yielded only 10 to 15 dB more attenuation. Attenuation was relatively flat over the frequency range 1 to 50 kHz and exhibited an attenuation rate of approximately 5 dB/100 ft for all frequencies and orientations. The communications radius of a 25-watt, roof-bolt voice radio system is predicted to be 1,200 to 1,400 feet.

Minimum attenuation for a roof-bolt-to-loop antenna system occurred along the axis of the roof-bolt antenna with the loop magnetic axis oriented vertically. The field strength produced by the roof-bolt antenna was relatively independent of frequency over the range 1 to 50 kHz. The attenuation rate averaged 4 dB/100 ft over all frequencies and orientations with individual measurements deviating only slightly from the average. The communications radius of a 25-watt roof-bolt-to-loop voice radio system is predicted to be 1,500 feet at 50 kHz and 800 feet at 1 kHz when the loop's magnetic axis is vertical.

### 2.5 ACKNOWLEDGMENT

The cooperation and assistance of management and engineering personnel at the Inland Steel Co. coal mine is gratefully acknowledged. Their interest, patience, and commitment of personnel and resources have made the field test program a success. Particular acknowledgment is due to Mr. Doug Dwosh and Mr. Mark Morgan for extra efforts to help get the job done.

### 2.6 REFERENCES

1. Farmer, R. A., and N. H. Shepherd, "Guided Radiation...The Key to Tunnel Talking," IEEE Trans on Vehicular Communications, pp 93-102, March 1965.
2. Crary, J. H., "Determination of the Electromagnetic Environment in Coal Mines," Final Technical Report, ITS, Boulder, Colorado, 1 March 1972.
3. Mine Communication and Monitoring Second Quarterly and Intermediate Annual Technical Progress Report (5 Sep to 4 Dec 1972) Department of Electrical Engineering - WVU, Morgantown, WVA.

---

 Experimental VLF to LF Tests at Robena No. 1 Mine

A later series of in-mine propagation studies were conducted under contract H0232056 in the Robena No. 1 mine on 12 March 1974, and the results are included in the text which follows. Large loop to small loop, small loop to large loop, line source to small loop, and small loop to line source arrangements are evaluated at separations of 50 ft, 100 ft, 200 ft, and 400 ft. In order for comparison of the experimental data with that obtained theoretically, all values are normalized to 10 watts input power and a 1-Hz bandwidth.

### 3.1 VLF and LF Tests

For the test setups for each particular configuration, refer to figures 3-1 through 3-3 of this section. Figures 3-4 through 3-11 graphically depict the results of the experimental data.

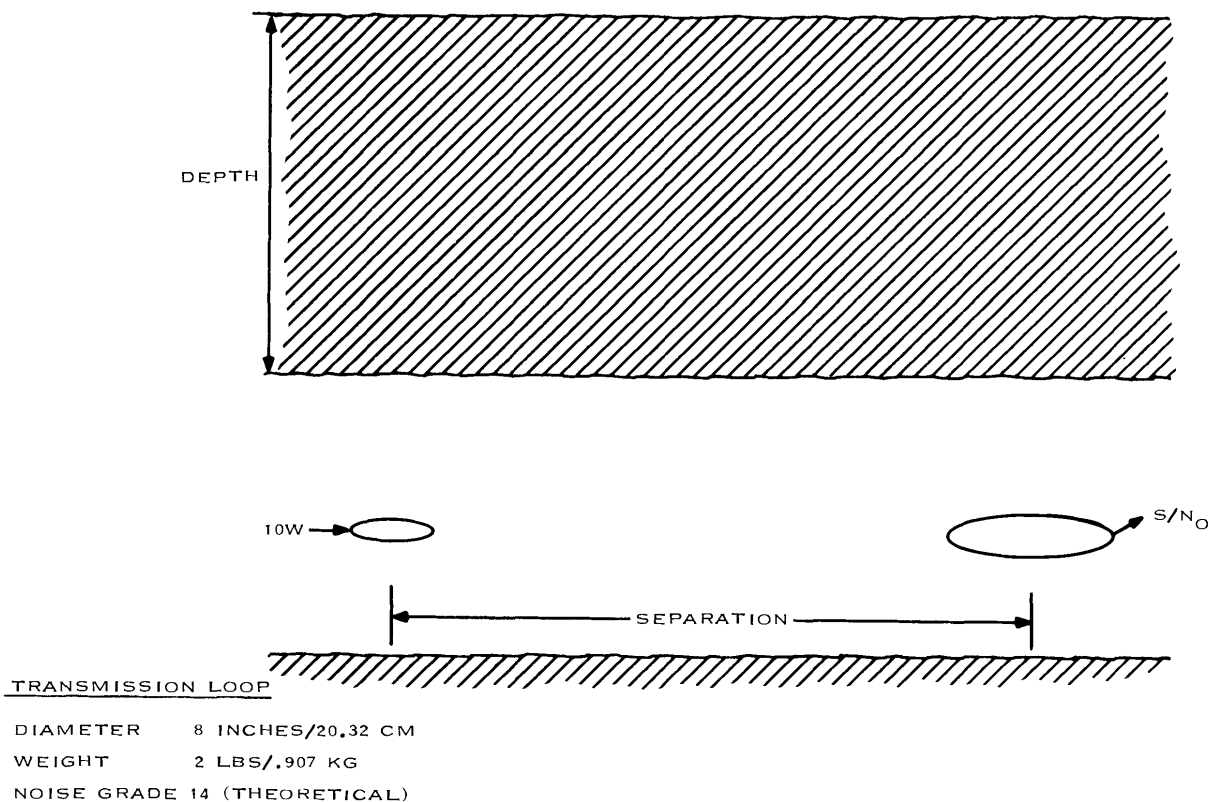
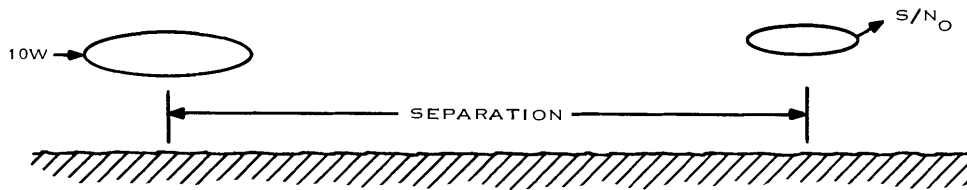
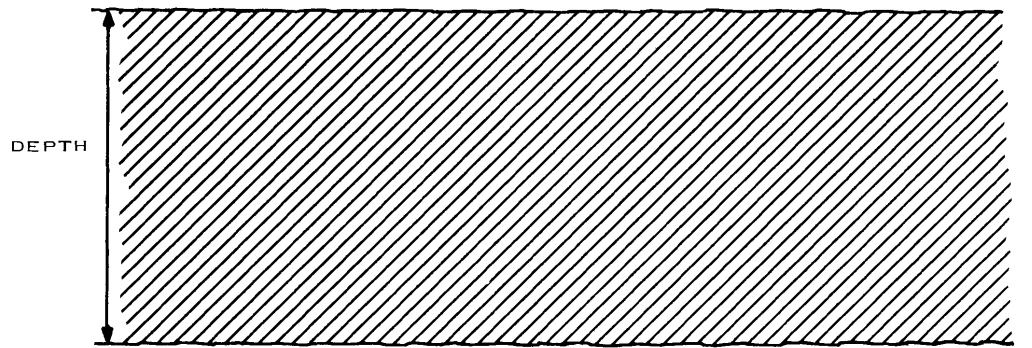

Figure 3-1. 8-Inch Loop to 20-Meter Loop.



TRANSMISSION LOOP

RADIUS 20 METERS/65.7 FT  
 WEIGHT 6 KG/13.23 LB  
 WIRE SIZE NO 10  
 NOISE GRADE 14 (THEORETICAL)

Figure 3-2. 20-Meter Loop to 8-Inch Loop.

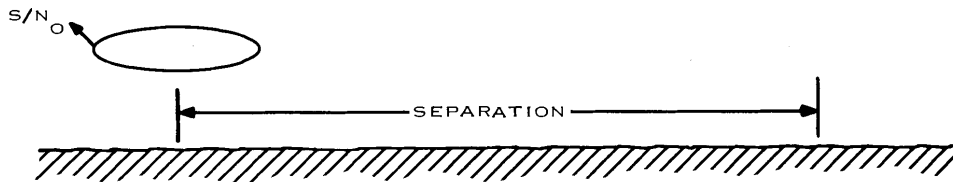
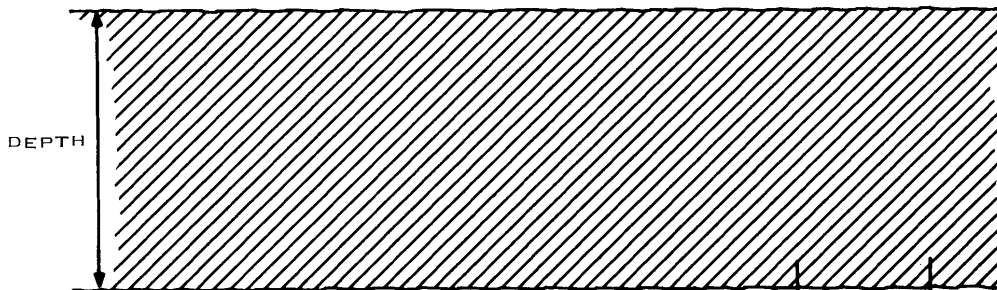

TRANSMITTING LINE

LENGTH 100 M/328 FT  
 WEIGHT 10.3 LB /4.67 KG  
 NOISE GRADE 14 (THEORETICAL)  
 WIRE SIZE NO 10

Figure 3-3. Line Source to Loop.

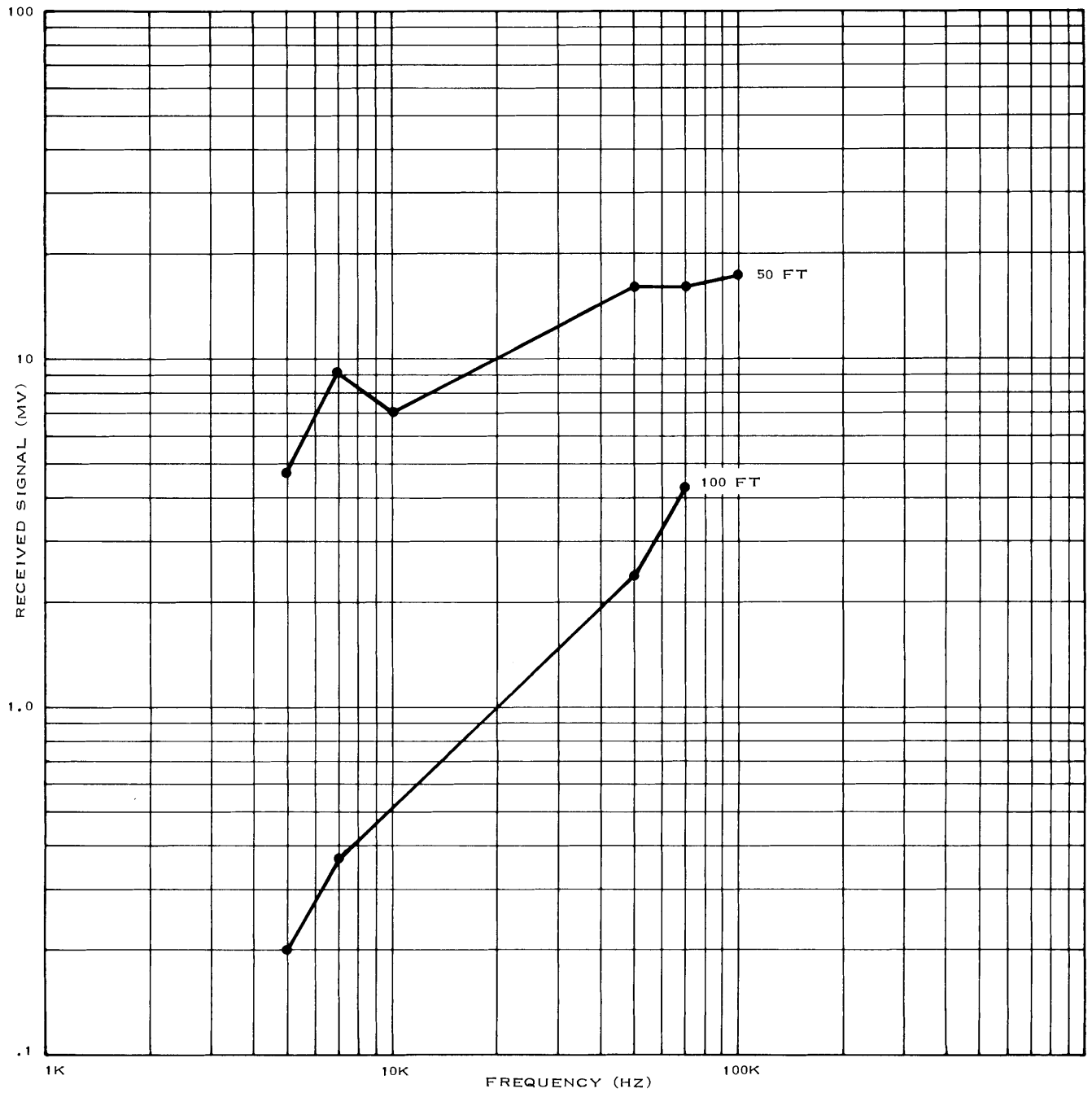

Figure 3-4. Received Signal Vs Frequency (8-Inch Loop to 20-Meter Loop).

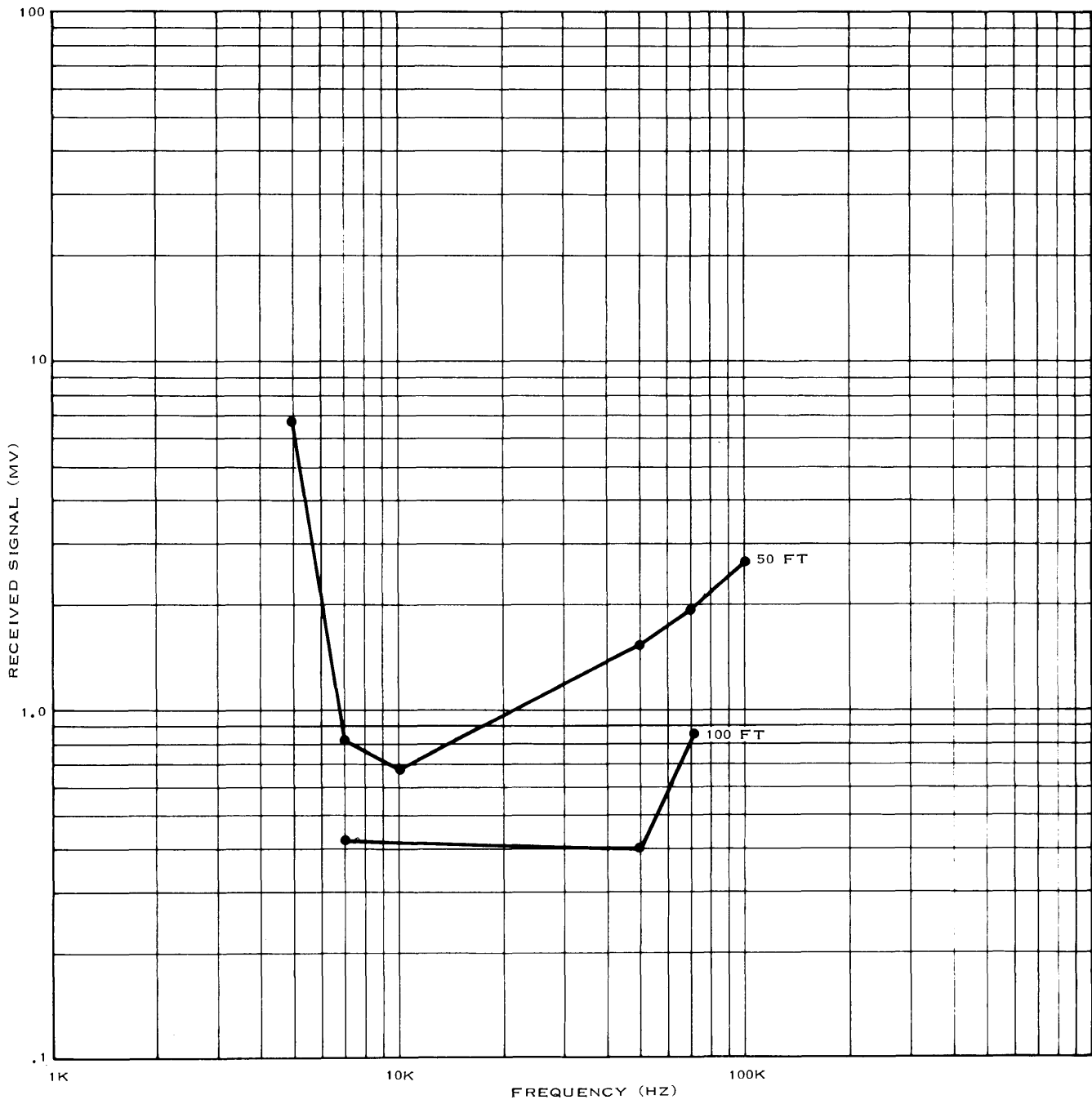

Figure 3-5. Received Signal Vs Frequency (8-Inch Loop to Roof Bolt).

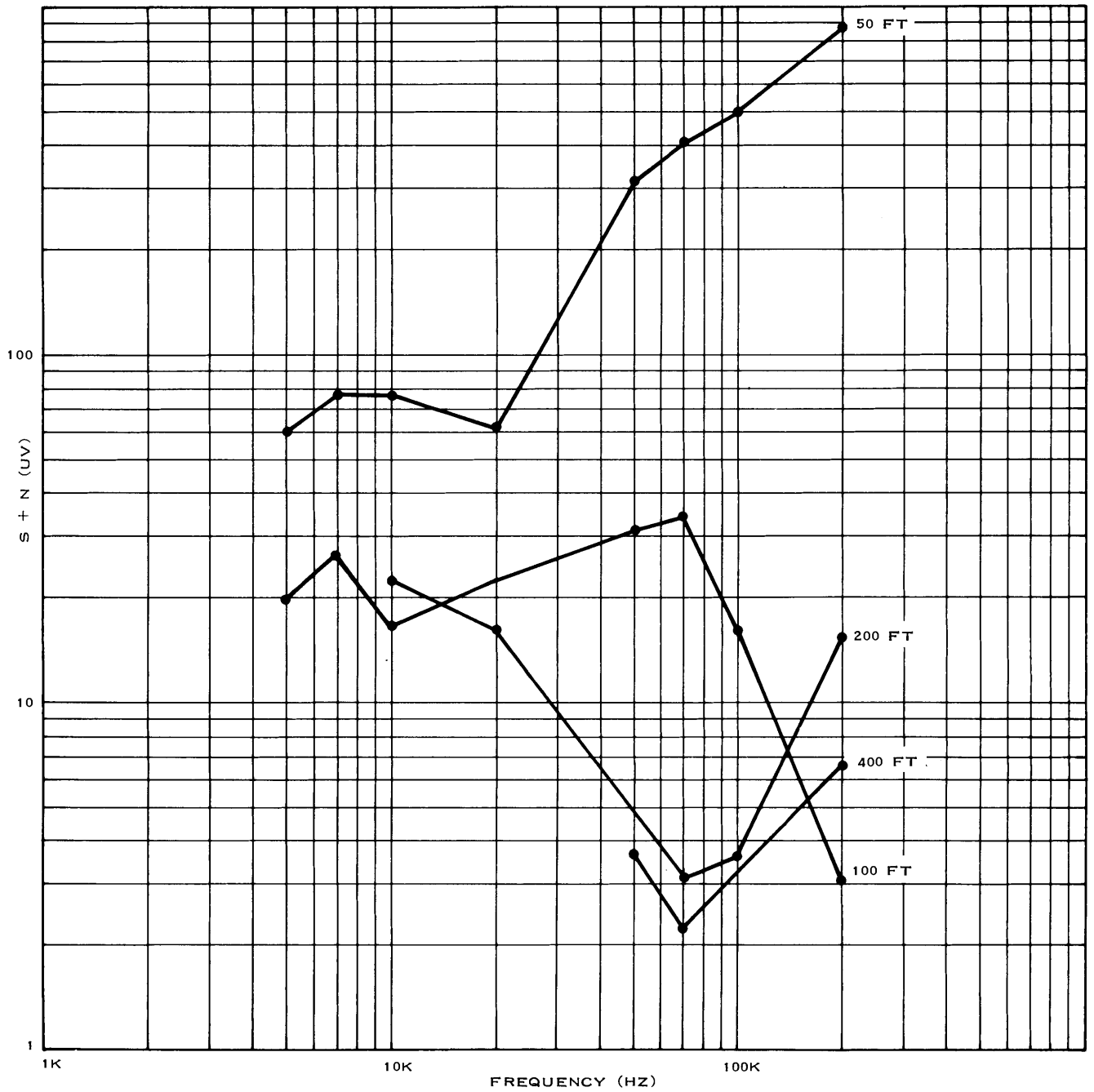

Figure 3-6. Received Signal Vs Frequency (Roof Bolt to 8-Inch Loop).

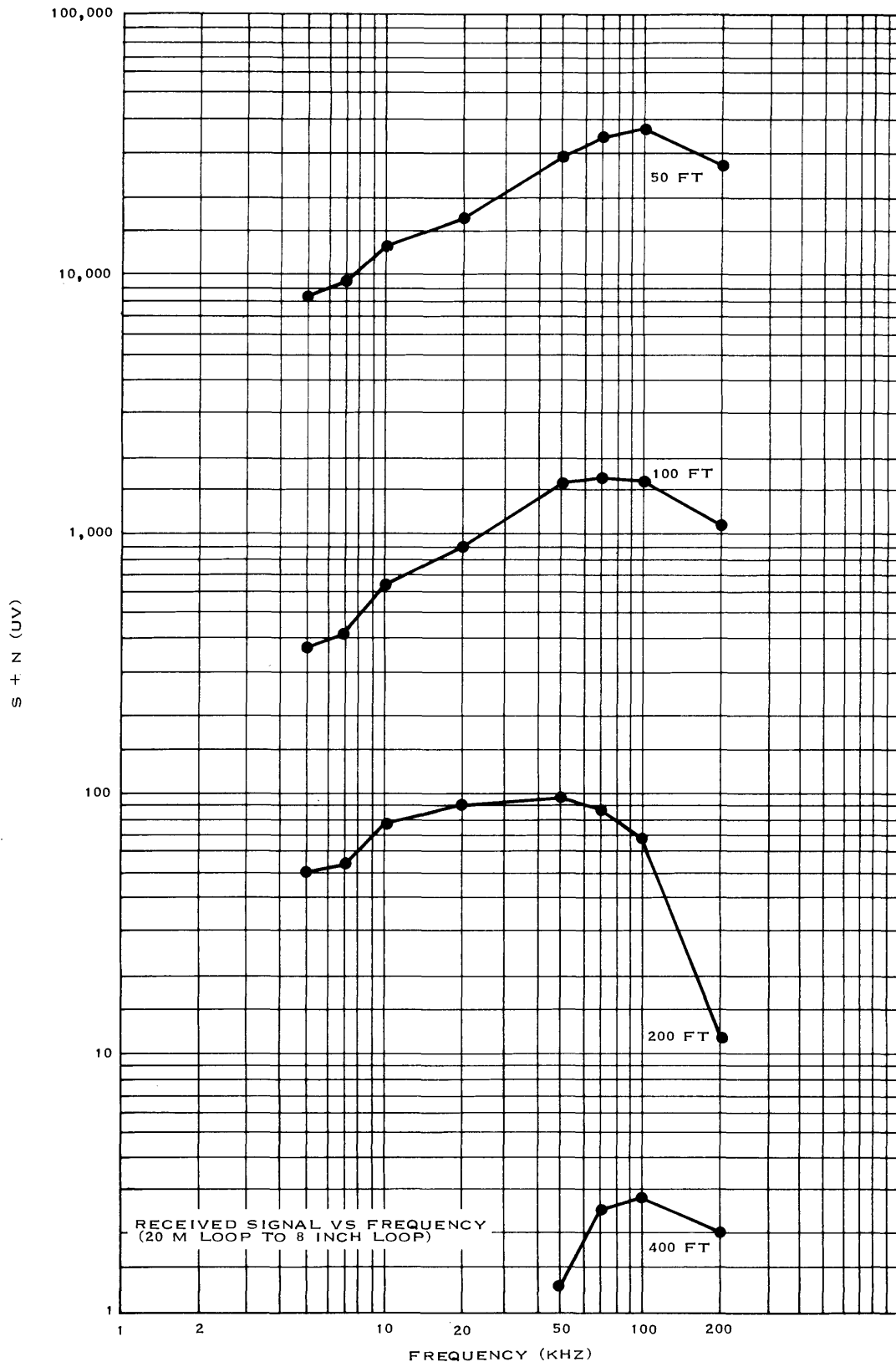

Figure 3-7. Received Signal Vs Frequency (20-Meter Loop to 8-Inch Loop).



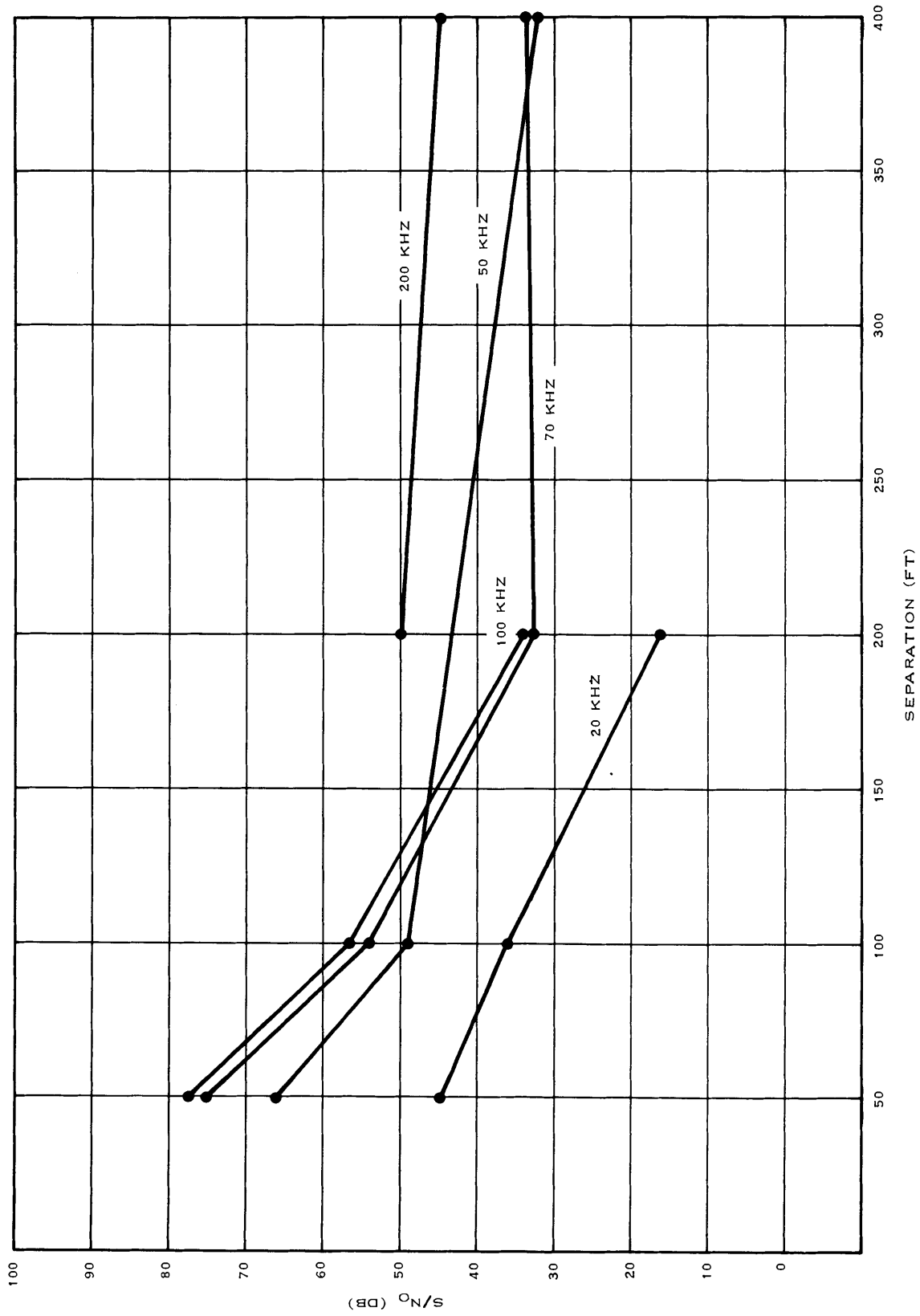

Figure 3-8. S/N<sub>0</sub> Vs Separation (Roof Bolt to 8-Inch Loop).

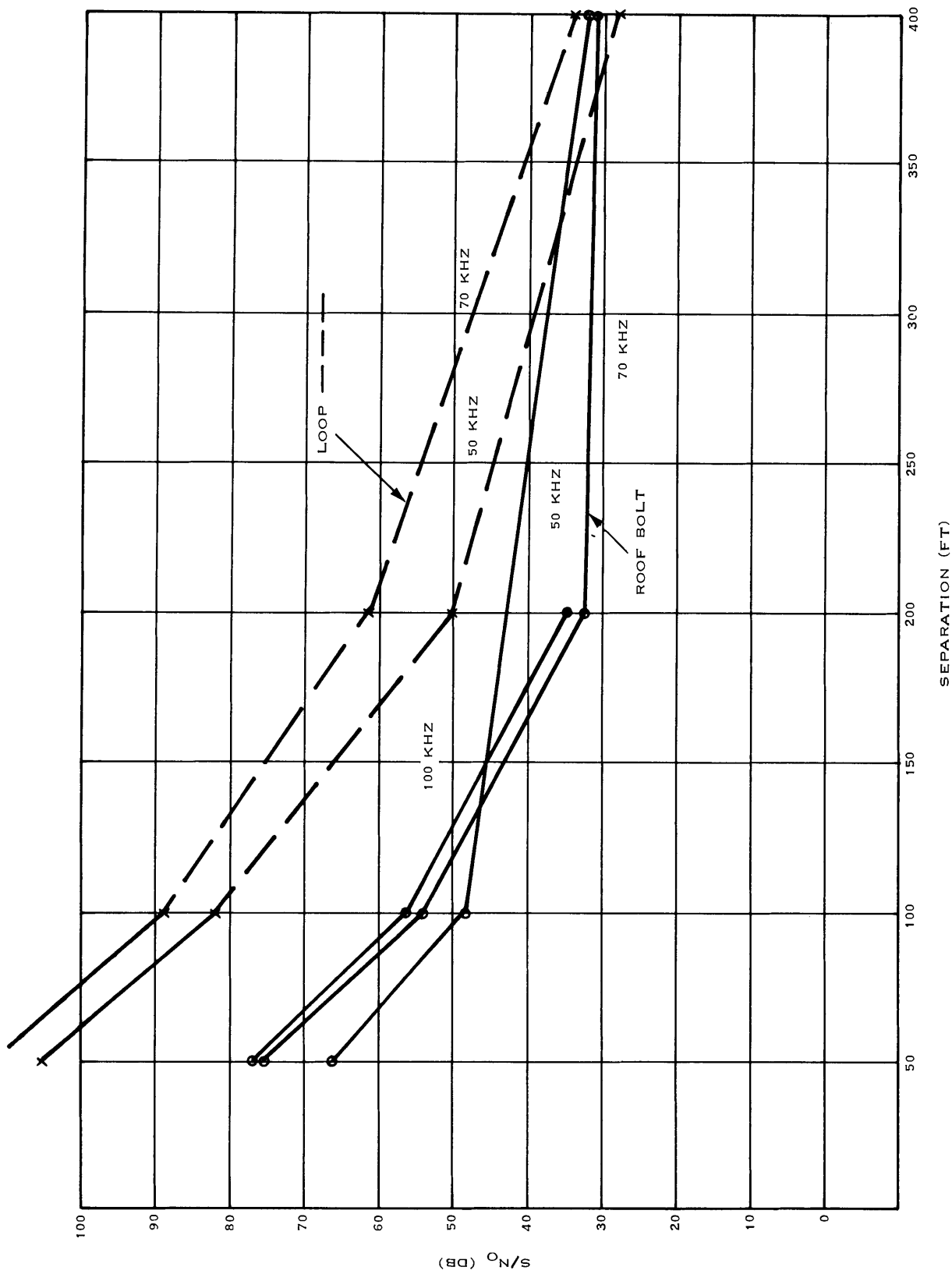

Figure 3-9. S/N<sub>0</sub> Vs Separation (20-Meter Loop to 8-Inch Loop and Roof Bolt to 8-Inch Loop).

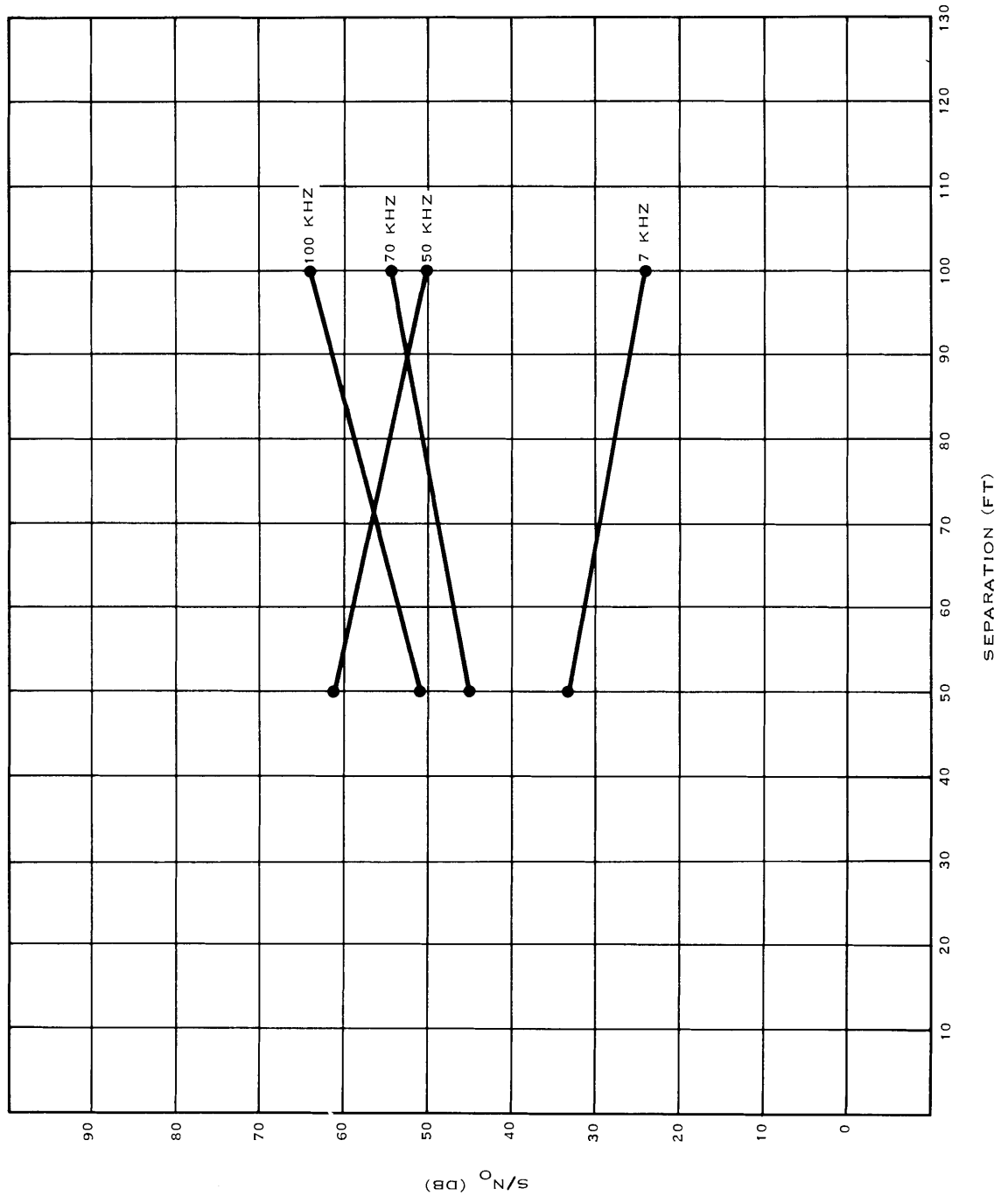

Figure 3-10. S/N<sub>0</sub> Vs Separation, (8-Inch Loop to Roof Bolt).

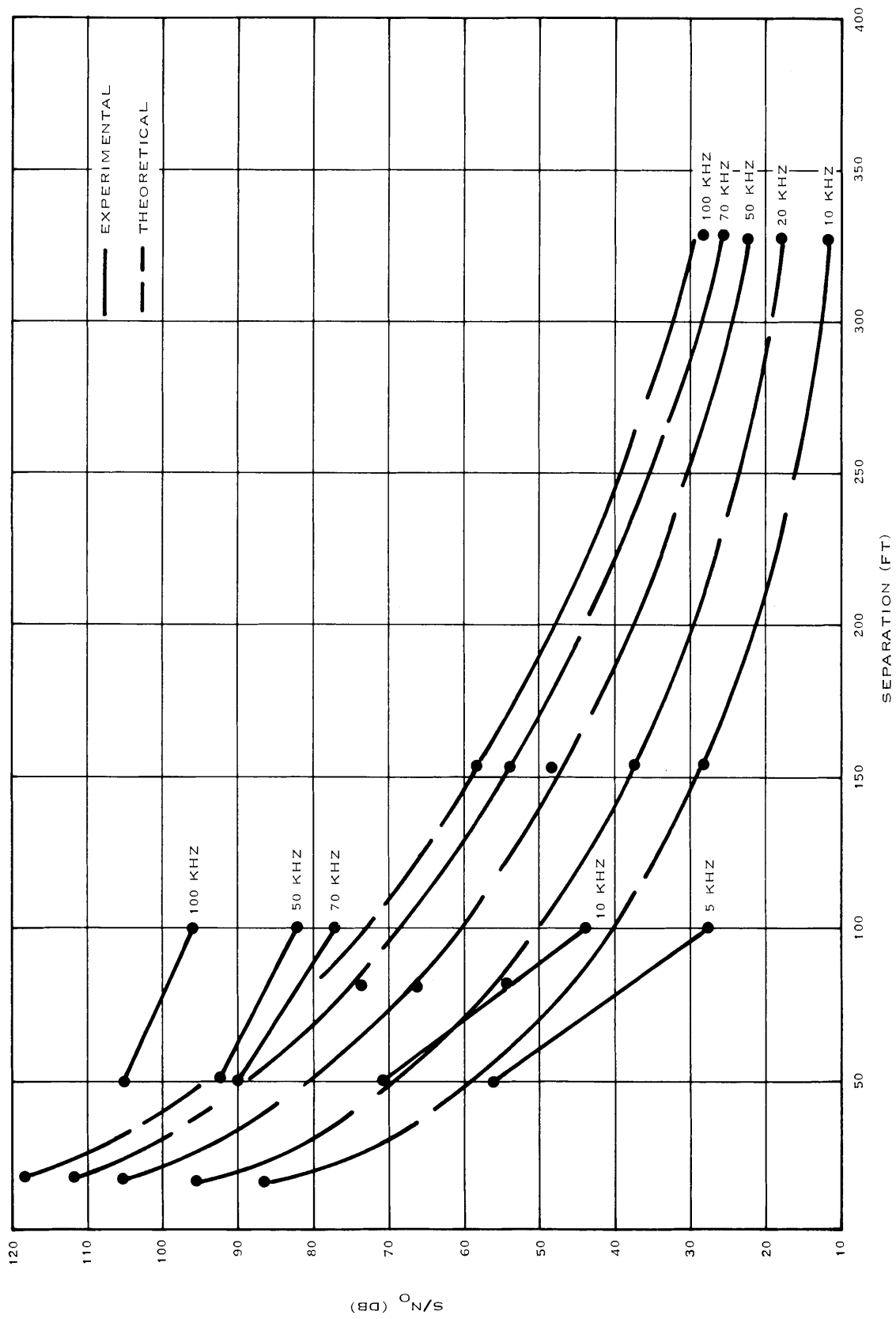

Figure 3-11.  $S/N_0$  Vs Separation (8-Inch Loop to 20-Meter Loop).

Experimental predictions obtained from the figures are as follows:

- a. The optimal frequency for a 4-inch radius transmit loop is in the 100-kHz range.
- b. The optimal frequency for a 20-meter transmit loop is the 100- to 200-kHz range.
- c. The optimal frequency for roof-bolt transmission is in the 100- to 200-kHz range.
- d. Loop-to-loop transmission is considerably better than line source to loop at the smaller separations; however, at separations of 400 feet, line source transmissions and 20-meter loop transmission appear equivalent. Predictions as to maximum attainable separation are not made, since readings beyond 400 ft are not available.
- e. Also since readings beyond a 400-ft separation could not be made, optimal frequency ranges will probably decrease at the larger separations.

In the preceding measurements, a VMD to VMD arrangement is employed for all loop-to-loop operations; that is, the planes of the transmitting and receiving loops are parallel to the horizontal. The curves illustrating coupling between line source and loop also indicate characteristics with the loop operated as a VMD. During the measurements, however, an anomaly was observed while transmitting with the line source. At the higher frequencies and at separations beyond 50 feet, greater signal levels were received with the receiving loop held parallel to the vertical. Up to a 400-foot separation, the greatest signal strength occurred with the loop parallel to the transmit antenna. At 400 feet, a strong signal was also received when the loop was perpendicular to the transmit antenna. These unexpected signals apparently are due to the higher frequencies being coupled into the 7200-volt line and then reradiated. However, more study in this area is required before firm conclusions can be made.

### 3.2 COMPARISON OF VLF PREDICTIONS

By use of the NBS noise data and the experimental readings, comparison of observed and predicted propagation can be made. The following graphs, figures 3-12 through 3-14, compare theoretical and experimental  $S/N_0$  ratios for a 20-meter loop transmitting to an 8-inch loop, an 8-inch loop to a 20-meter loop, and a 200-foot line source transmitting to a loop. Many discrepancies exist. These can be explained in part by the following:

- a. Theory assumed a homogeneous medium of  $\sigma = 0.01$  Mho/m. Actual conductivity will vary with the layers of different material.
- b. Effect of steel in roof (roof bolts) is not included in theory.
- c. Effect of other conducting material, such as trolley lines, was left untouched. In actual communication, these conducting materials may be usable to improve the received signal as demonstrated in the experimental data.
- d. Experimented readings employ actual mine noise that may be higher or lower than noise grade 14, which was used for theoretical calculations.

One of the major differences observed between the predictions and measurements was received signal strength. In theory the received signal could be expected to be highest at the lower frequencies and to steadily decline with increasing frequency. In many cases, however, the experimental received signal increased with increasing frequency. It appears that, in the true mine environment, as the frequency is increased, more scattering of the transmitted electromagnetic waves back into the tunnel by the tunnel walls or roof bolts occurs, thus resulting in a higher received signal. However, more study and experimentation will have to be done in order to obtain a reliable explanation for this inconsistency.

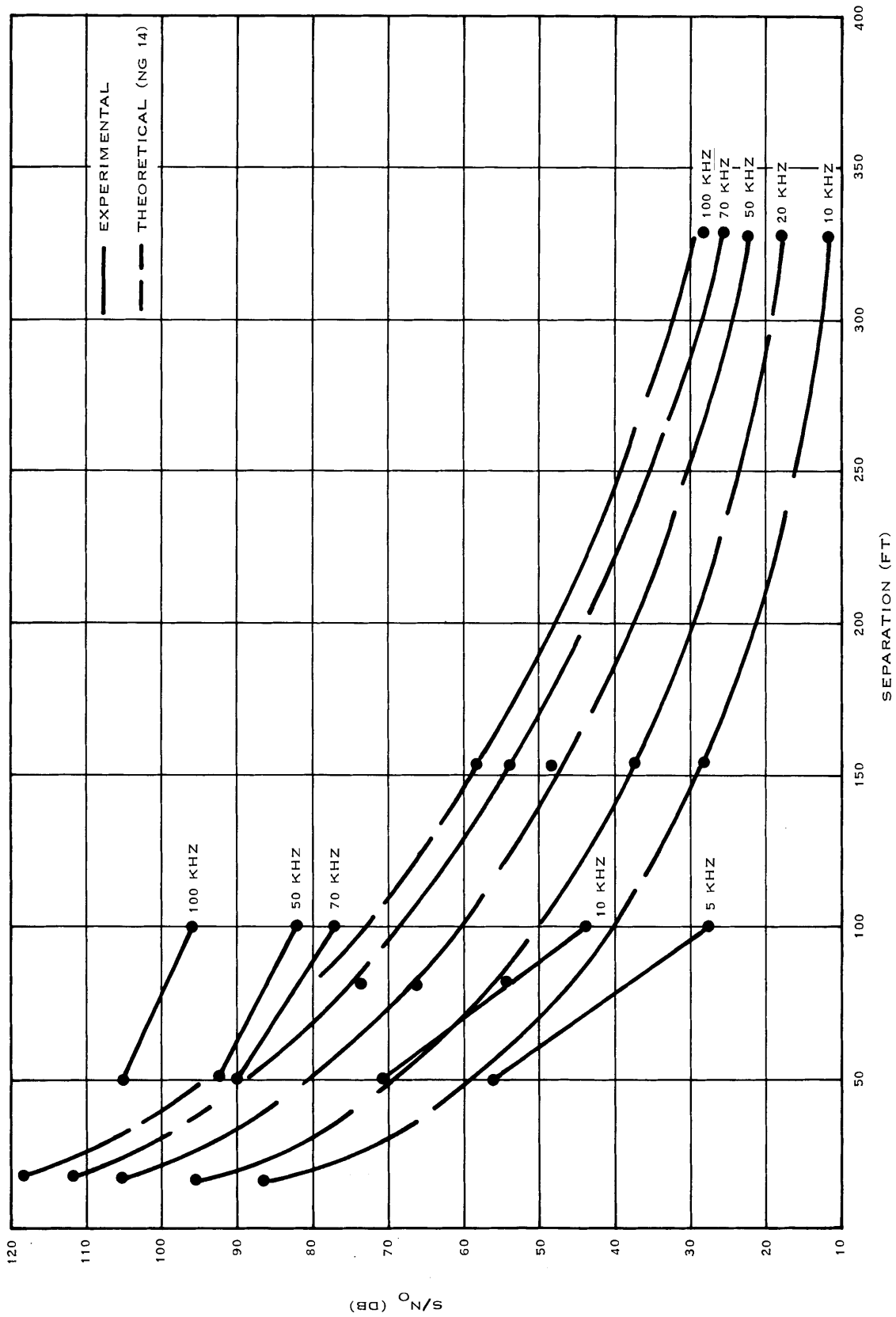

Figure 3-12. S/N<sub>0</sub> Vs Separation (8-Inch Loop to 20-Meter Loop).

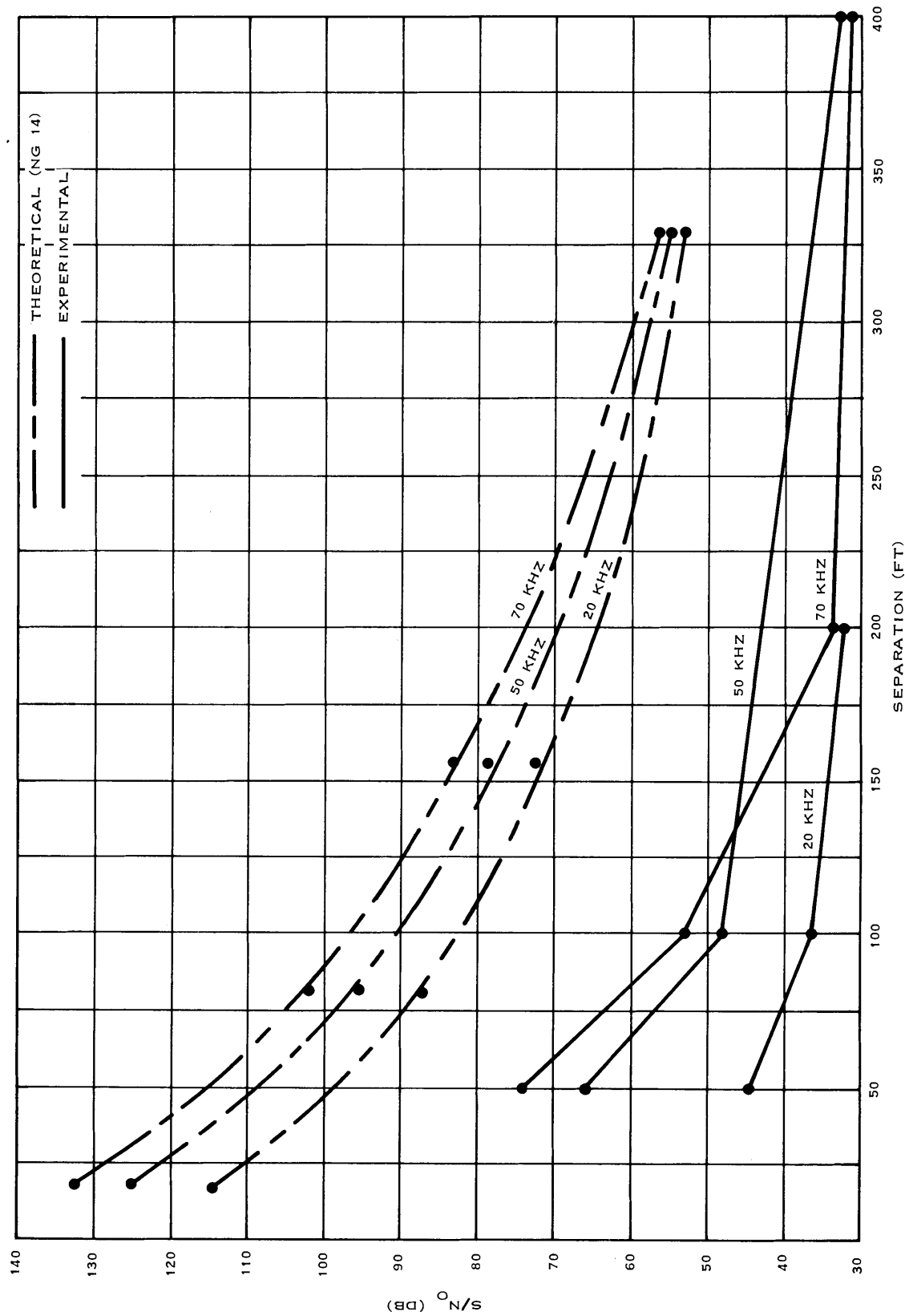

Figure 3-13.  $S/N_0$  Vs Separation (Roof Bolt-to-Loop Transmission).

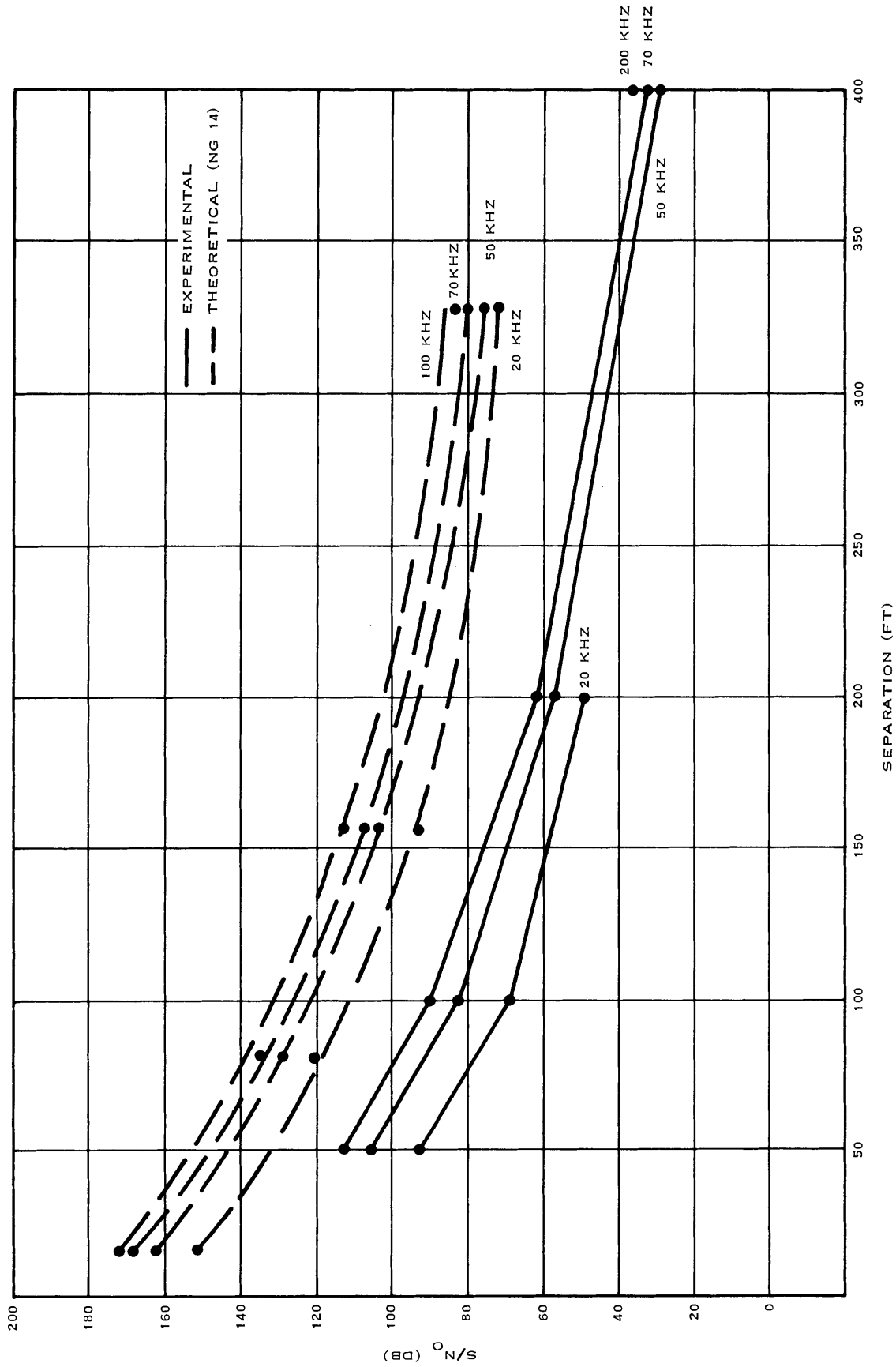

Figure 3-14. S/N<sub>0</sub> Vs Separation (20-Meter Loop to 8-Inch Loop).



Overall comparison between experimental and calculated data yields the following conclusions:

- a. Measured data indicated an optimum frequency range comparable to that obtained in theory at these separations.
- b. In small loop transmission measured  $S/N_0$  ratio was larger than that calculated.
- c. Large loop and roof-bolt transmission provided higher  $S/N_0$  ratio in theory than that obtained experimentally.
- d. Actual roof-bolt antennas exhibit a much larger impedance than that predicted. This impedance was also observed to be capacitive instead of inductive as expected. The indication is that such impedances will vary drastically from mine to mine and be dependent on the composition of the roof strata. Antenna impedance obtained at Robena are shown in tables 3-1 and 3-2.

Table 3-1. Roof-Bolt Antenna Measurements, Robena No. 1.

| F   | R            | L ( $\mu$ H) | X        | Z         | $\theta$ |
|---|--------------|--------------|----------|-----------|----------|
| Antenna = 100 Feet, 100 Feet Between Bolts      |              |              |          |           |          |
| 20 kHz  | 288 $\Omega$ | -375         | -47.124  | 291.83    | -9.293   |
| 50 kHz  | 258 $\Omega$ | -148         | -46.496  | 262.156   | -10.216  |
| 100 kHz   | 224 $\Omega$ | -74          | -46.496  | 228.775   | -11.726  |
| 200 kHz   | 200 $\Omega$ | -21.6        | -27.143  | 201.83345 | -7.729   |
| 500 kHz   | 147 $\Omega$ | +23          | 72.257   | 163.799   | 26.176   |
| Antenna = 200 Feet, 200 Feet Between Bolts      |              |              |          |           |          |
| 30 kHz  | 425 $\Omega$ | -450         | -84.82   | 433.38    | -11.2866 |
| 50 kHz  | 400 $\Omega$ | -273         | -85.755  | 409.089   | -12.1    |
| 100 kHz   | 350 $\Omega$ | -140         | -87.955  | 360.882   | -14.11   |
| 200 kHz   | 278 $\Omega$ | -82          | -103.044 | 296.483   | -20.338  |
| 500 kHz   | 228 $\Omega$ | 34.8         | 109.327  | 252.856   | 25.618   |
| Antenna = 400-Foot Wire, 385 Feet Between Bolts |              |              |          |           |          |
| 20 kHz  | 340 $\Omega$ | -278         | -34.934  | 341.79    | -5.866   |
| 50 kHz  | 312 $\Omega$ | -72          | -22.619  | 312.819   | -4.146   |
| 100 kHz   | 292 $\Omega$ | 7            | 4.398    | 292.033   | 0.8629   |
| 200 kHz   | -            | -            | -        | -         | -        |
| 500 kHz   | -            | -            | -        | -         | -        |

Table 3-1. Roof-Bolt Antenna Measurements, Robena No. 1 (Cont).

| F   | R            | L ( $\mu\text{H}$ ) | X      | Z       | $\theta$ |
|---|--------------|---------------------|--------|---------|----------|
| 200- Foot Roof-Bolt Antenna, Willow Tree Main |              |                     |        |         |          |
| Robena No. 1, 10-Foot Roof Bolts              |              |                     |        |         |          |
| 20 kHz  | 530 $\Omega$ | -                   | -      |         |          |
| 50 kHz  | 500 $\Omega$ | -193 $\mu\text{H}$  | -60.63 | 503.662 | -6.914   |
| 100 kHz                                       | 420 $\Omega$ | -113 $\mu\text{H}$  | -71.0  | 475.332 | -8.59    |
| 200 kHz                                       | 420 $\Omega$ | -43 $\mu\text{H}$   | 54.04  | 423.46  | 7.332    |
| 500 kHz                                       | 390 $\Omega$ | 0                   | 0      | 390     | 0°       |

Table 3-2. Roof-Bolt Antenna Measurements, Robena No. 1  
(Just Outside Dispatcher's Shed).

| FREQ (Hz)   | R ( $\Omega$ ) | L ( $\mu\text{H}$ ) | X        | Z       | $\theta$ |
|---|----------------|---------------------|----------|---------|----------|
| Antenna $\approx$ 200-Foot Wire, 180 Feet Between Bolts |                |                     |          |         |          |
| 20 k  | 371            | -398                | -50.014  | 374.356 | -7.678   |
| 50 k  | 338            | -174                | -54.664  | 342.392 | -9.187   |
| 100 k   | 299            | -73                 | -45.867  | 302.498 | -8.721   |
| 200 k   | 258.5          | -19.4               | -24.374  | 259.646 | -5.386   |
| 500 k   | 242            | +59.6               | 187.238  | 306.0   | 37.729   |
| Antenna $\approx$ 200-Foot Wire, 150 Feet Between Bolts |                |                     |          |         |          |
| 20 k  | 415            | -470                | -59.062  | 419.18  | -8.01    |
| 50 k  | 372            | -228                | -71.628  | 378.833 | -10.899  |
| 100 k   | 322            | -102                | -64.088  | 328.32  | -11.257  |
| 200 k   | 282            | -23                 | -28.9026 | 283.477 | -5.85    |
| 500 k   | 235            | 55.4                | 174.044  | 292.43  | 36.524   |

Table 3-2. Roof-Bolt Antenna Measurements, Robena No.1

(Just Outside Dispatcher's Shed) (Cont).

| FREQ (Hz)  | R ( $\Omega$ ) | L ( $\mu$ H) | X       | Z       | $\theta$ |
|--|----------------|--------------|---------|---------|----------|
| Antenna = 50-Foot Wire $\approx$ 40 Feet Between Bolts |                |              |         |         |          |
| 10 k   | 165            | -290         | -18.22  | 166.003 | -6.30    |
| 20 k   | 158            | -168         | -21.112 | 159.4   | -7.61    |
| 50 k   | 142            | -70          | -22.0   | 143.69  | -8.807   |
| 100 k  | 134            | -38.4        | -24.13  | 136.155 | -10.208  |
| 200 k  | 115            | -6.5         | -8.168  | 115.289 | -4.063   |
| 500 k  | 91             | 13.1         | 41.155  | 99.873  | 24.335   |

### 3.3 VLF SUMMARY

Preliminary analysis of vlf propagation within coal mines indicates adequate operation within a limited range. Figure 3-15 shows that intramine propagation characteristics are such that signal strengths, from an 8-inch diameter loop, vary several dB to in excess of 100 dB below those expected from surface transmission at the same displacements. Assuming 10 watts of input power and a 20-meter radius transmitting loop or roof-bolt transmitter, communication should be possible in excess of 150 meters (492 ft). Larger transmit distances seem possible by using techniques to couple into conductive devices such as a trolley wire. Based upon present knowledge, a vertical magnetic dipole (VMD) antenna arrangement provides the best signal-to-noise ratio for maximum displacement for a portable unit. Large loop-to-loop transmissions at lesser displacements provide the best  $S/N_0$ ; however, at larger displacements, line source to loop and large loop to loop are relatively equivalent.

The impedance presented by the roof bolt at the Robena Mine was capacitive and much higher than expected. Instead of the predicted inductive load of 50 to 100 ohms, a capacitive load of 400 to 500 ohms was measured. Due to the large ohmic resistance, absence of radiation resistance, and the short length of the roof bolt, efficient signal coupling is rather poor.

Because of the shortage of time and financing, ultimate solutions may not have been found. Much more study and experimental tests are needed in this area to obtain firm conclusions as to propagated fields of all the antenna arrangements, especially the roof bolt.

### 3.4 TABLES

The tables in appendix B show actual measured frequency, voltage, current, noise, and signal-plus-noise readings obtained in the Robena Mine for the various antenna arrangements.

$(s + n)/n$  was calculated in dB and normalized to 10 watts input power, 1-Hz bandwidth, and corrected for length and weight. These values were used in obtaining the experimental graphs evaluated earlier.

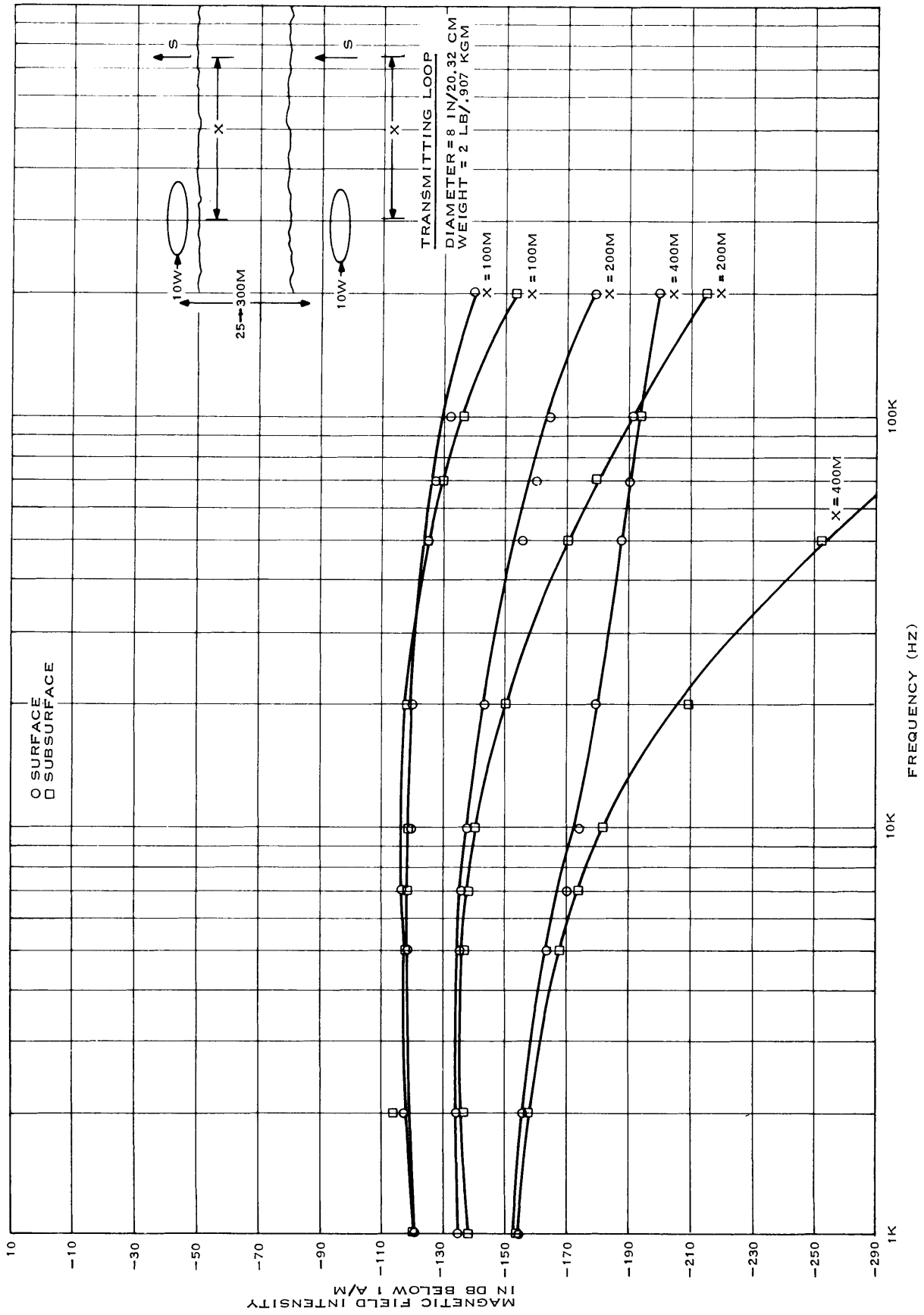

Figure 3-15. Lateral Magnetic Field Intensity for Varying Displacement.

With the foregoing experiments as a reference, many uhf propagation predictions can be made. Testing arrangements consist of a transceiver centrally located in a typical mine cross section transmitting to a portable unit. For frequencies of 415 MHz and 1 GHz, a 1-watt portable transceiver transmitting to a 1-watt portable transceiver is shown along with a 20-watt fixed station transceiver transmitting to a 1-watt portable unit. These arrangements are also shown with the addition of corner reflectors that reflect the propagated waves 90 degrees to the original mode of travel, thus allowing for greater overall coverage. Figures 4-1 through 4-10 are examples of coal mine entries and crosscuts with propagation predictions for different uhf system arrangements shown. Variance of the predicted values due to obstructions, such as stoppings, will also be discussed.

Major uhf characteristics are as follows:

- a. Optimal frequency is in the 1-GHz range.
- b. Corner attenuation is quite pronounced for both 415 MHz and 1 GHz. Propagation around more than one corner is quite remote.
- c. Maximum straight line tunnel propagation distance for a system with 144-dB range at 415 MHz is 1,800 ft, while that for 1 GHz is 3,300 ft.
- d. Use of corner reflectors greatly enhance propagation coverage.
- e. Horizontal polarization provides approximately 25 dB higher received signal than does vertical or approximately 18 dB higher than does cross polarization.
- f. Depolarization is noted after propagation around corners.

It should be noted that all predictions are based on testing that was done in an actual mine environment with no visual contact between transmitter and receiver.

The presence of stoppings for direction of airflow, passages blocked by machinery, or blockage caused by a roof fall seriously limit the communication range of a uhf system. Obstructions highly attenuate all uhf signal transfer, thus making the same systems rather impractical for some mine applications. Additional testing needs to be completed to obtain a quantitative value for the effect these stoppings have on uhf systems.

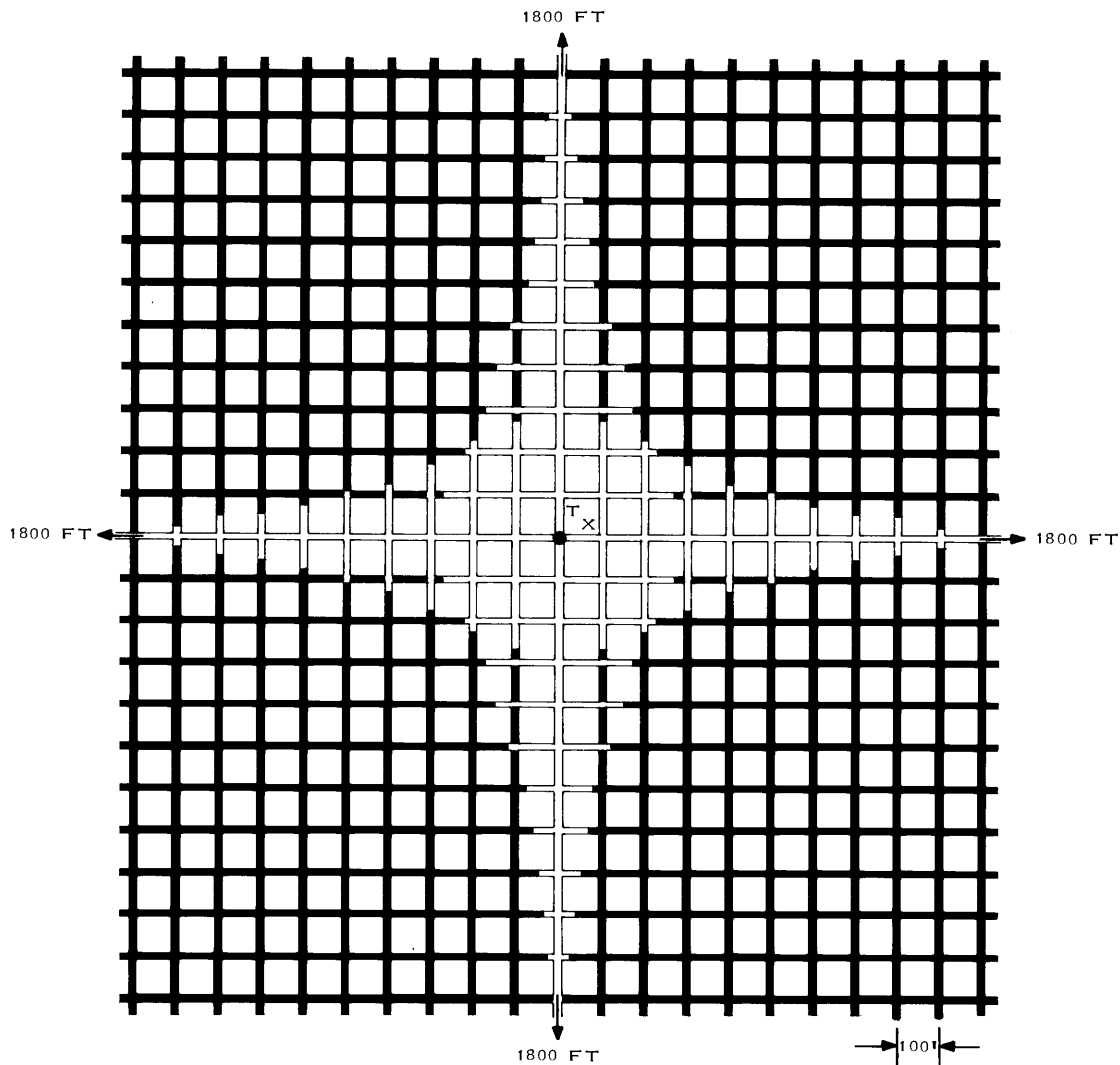

Figure 4-1. UHF Propagation (1-Watt Transceiver Transmitting to 1-Watt Transceiver - 1,800 ft).

Transmit frequency - 415 MHz

Polarization - Horizontal

Base station - 1-watt transceiver

Portable station - 1-watt transceiver

System range - 144 dB

Antenna - Omnidirectional, horizontal polarized, turnstyle

(Darkened area indicates loss of transmission)

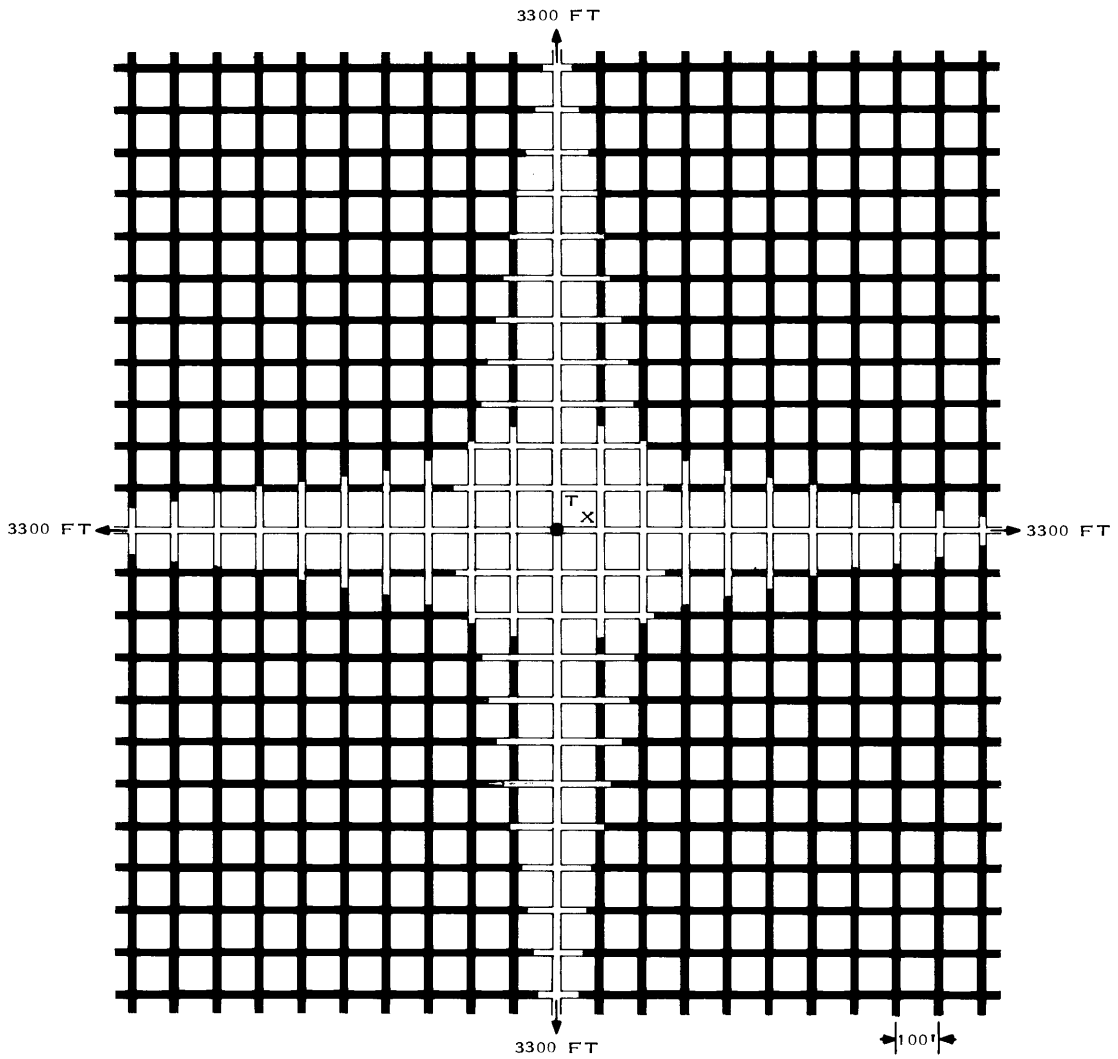

Figure 4-2. UHF Propagation (1-Watt Transceiver Transmitting to 1-Watt Transceiver - 3,300 ft).

Transmit frequency - 1GHz

Polarization - Horizontal

Base station - 1-watt transceiver

Portable station - 1-watt transceiver

System range - 144 dB

Antenna - Omnidirectional, horizontal polarization, turnstyle

(Darkened area indicates loss of transmission)

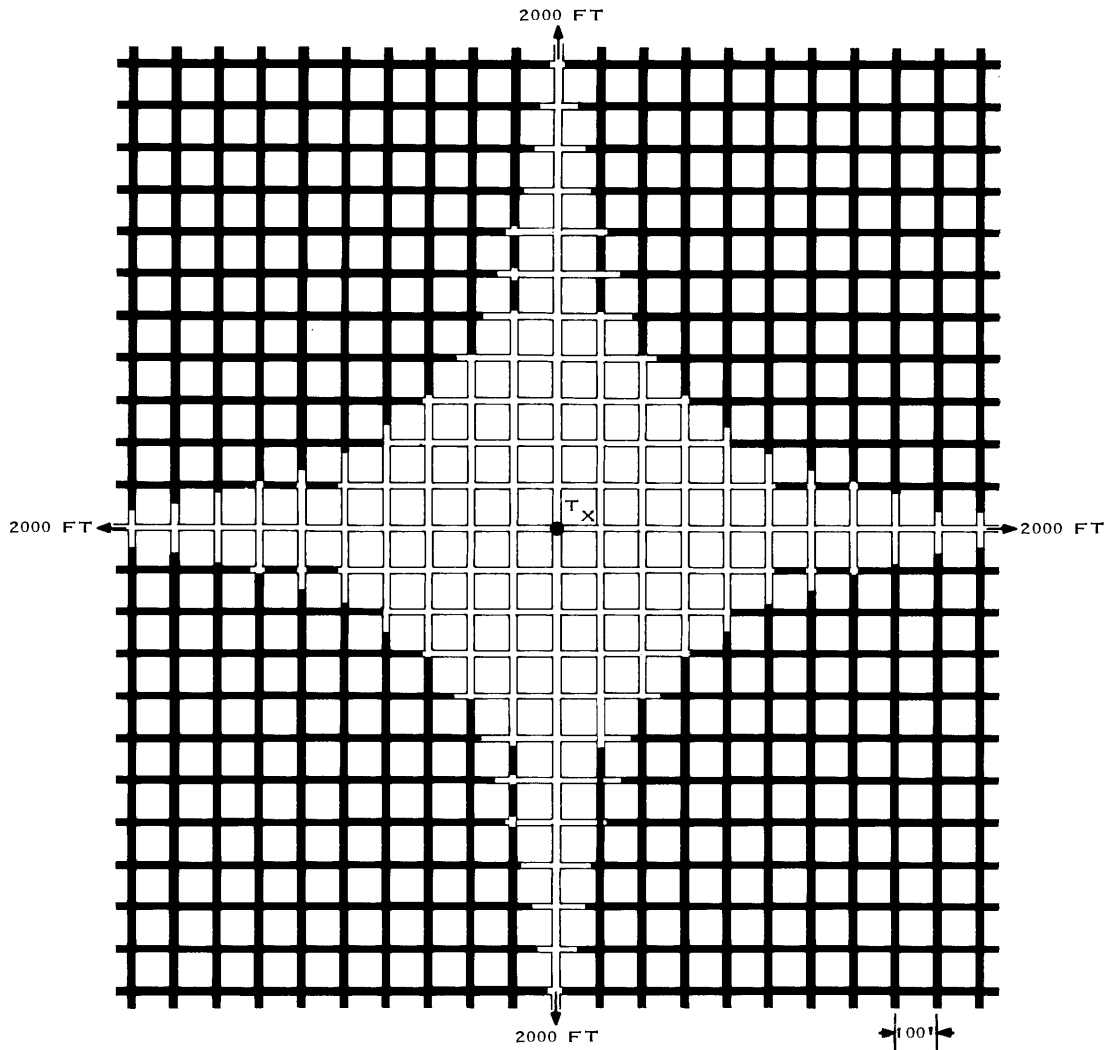

Figure 4-3. UHF Propagation (20-Watt Transceiver Transmitting to 1-Watt Transceiver - 2,000 ft).

Transmit frequency - 415 MHz

Polarization - Horizontal

Base station - 20-watt transceiver

Portable station - 1-watt transceiver

System range - 157 dB

Antenna - Omnidirectional, horizontal polarized, turnstyle

(Darkened area indicates loss of transmission)



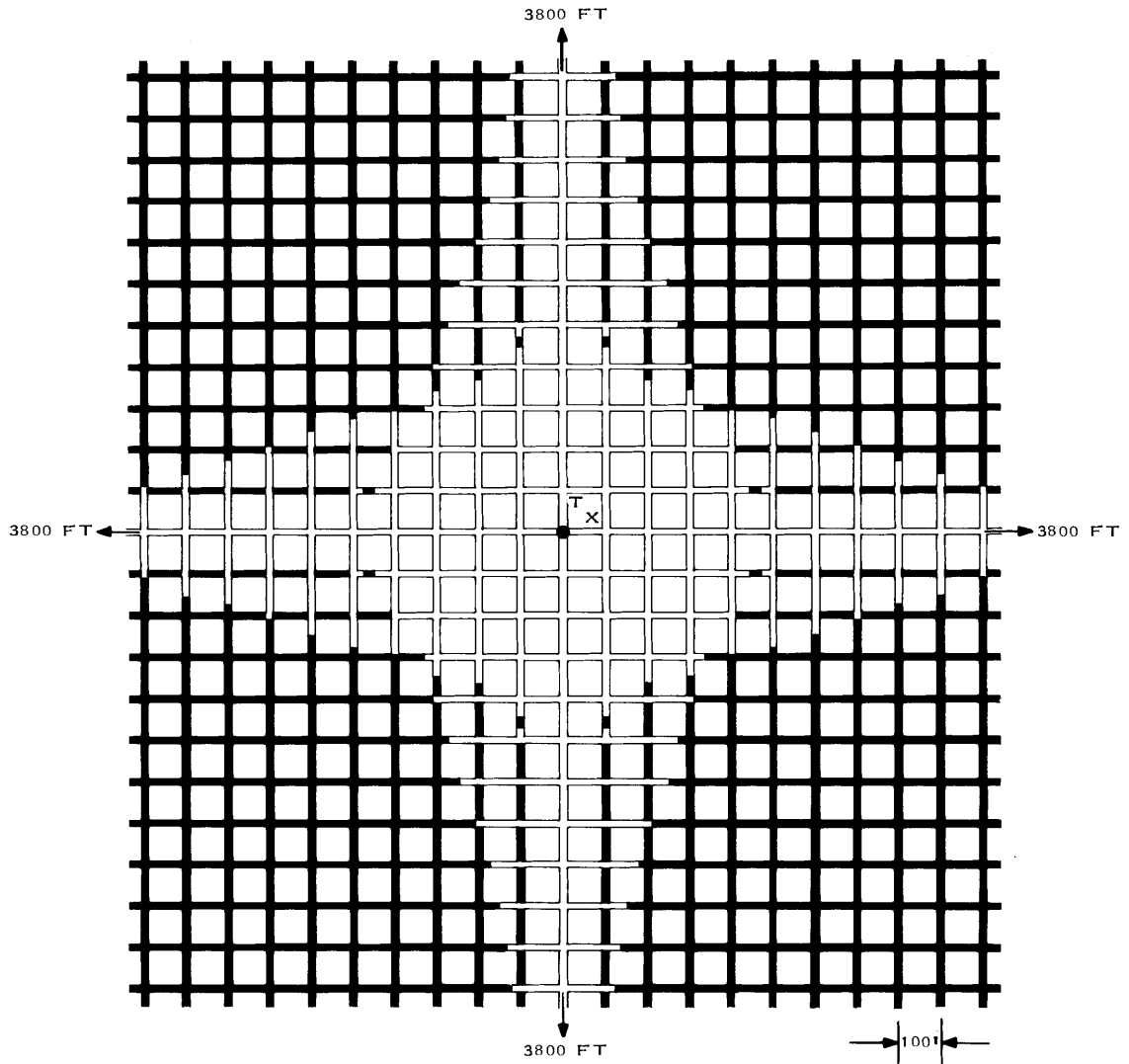

Figure 4-4. UHF Propagation (20-Watt Transceiver Transmitting to 1-Watt Transceiver - 3,800 ft).

Transmit frequency - 1 GHz

Polarization - Horizontal

Base station - 20-watt transceiver

Portable station - 1-watt transceiver

System range - 157 dB

Antenna - Omnidirectional, horizontal polarized, turnstyle

(Darkened area indicates loss of transmission)

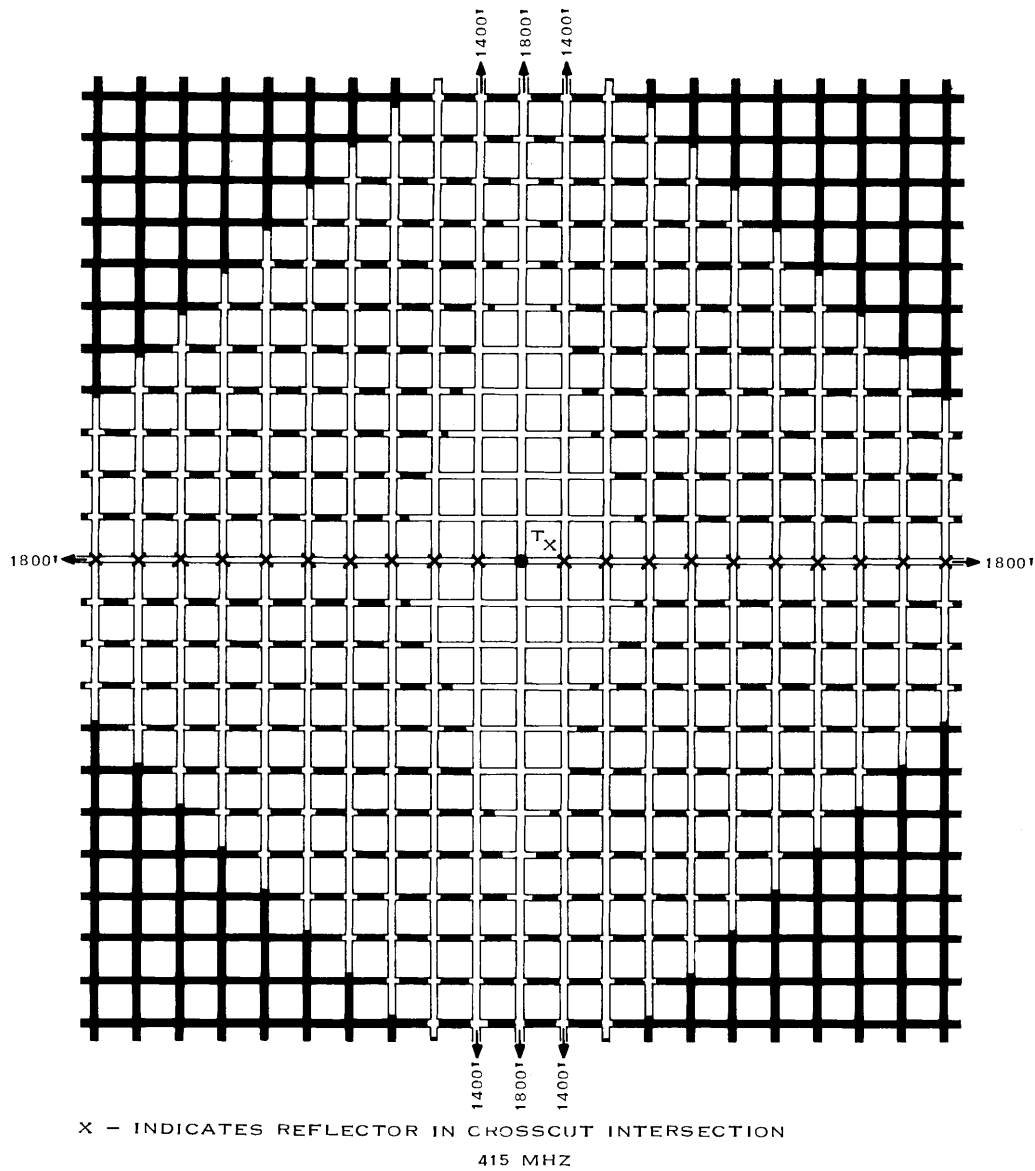

Figure 4-5. UHF Propagation (1-Watt Transceiver Transmitting to 1-Watt Transceiver With Corner Reflectors - 1,800 ft).

Transmit frequency - 415 MHz

Polarization - Horizontal

Base station - 1-watt transceiver

Portable station - 1-watt transceiver

System range - 144 dB

Antenna - Omnidirectional, horizontal polarization, turnstyle

Reflector gain over isotropic - 24 dB

(Darkened area indicates loss of transmission)

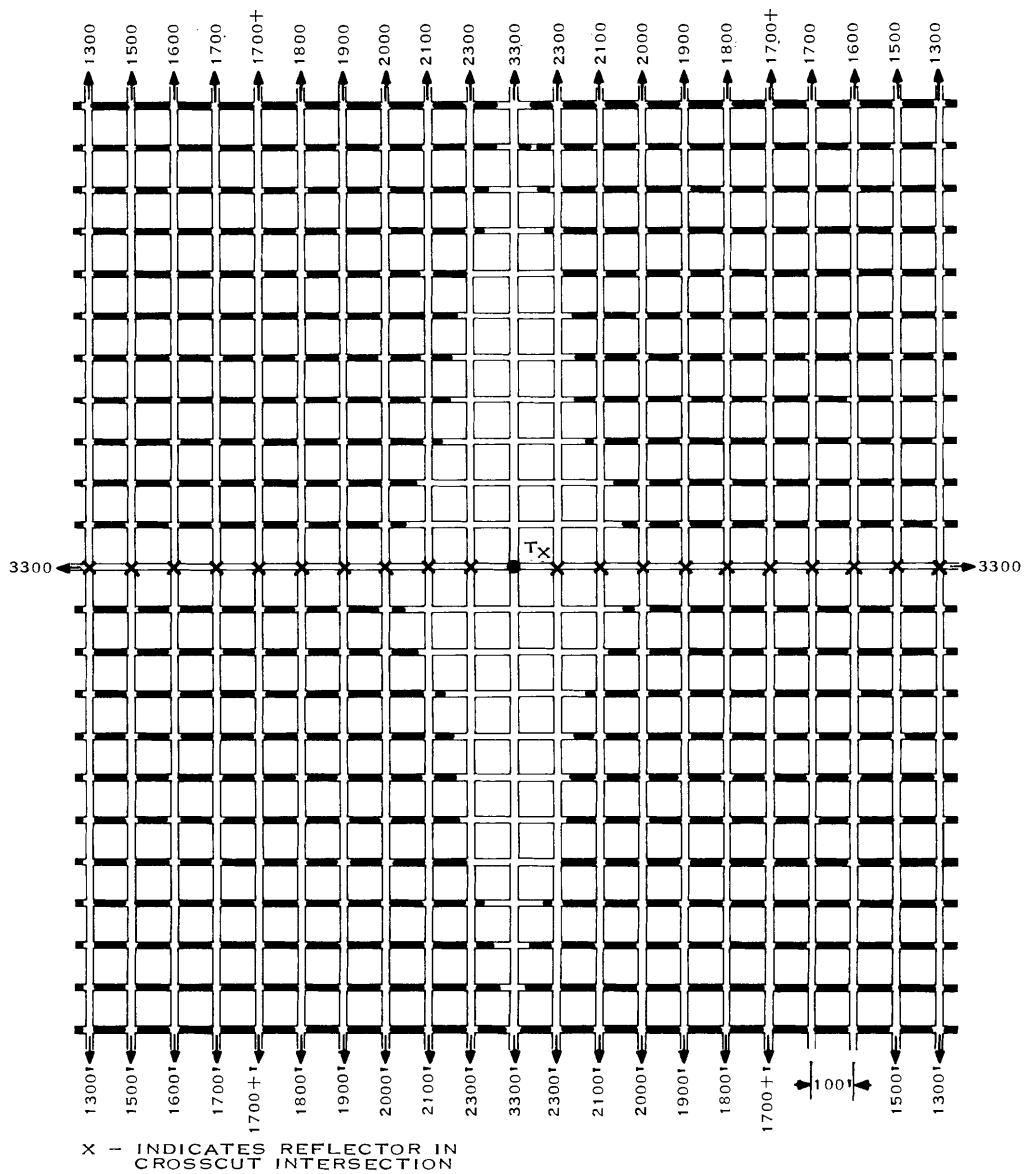

Figure 4-6. UHF Propagation (1-Watt Transceiver Transmitting to 1-Watt Transceiver, With Corner Reflectors - 3,300 ft).

Transmit frequency - 1 GHz

Polarization - Horizontal

Base station - 1-watt transceiver

Portable station - 1-watt transceiver

System range - 144 dB

Antenna - Omnidirectional, horizontal polarization, turnstyle

Reflector gain over isotropic - 24 dB

(Darkened area indicates loss of transmission)

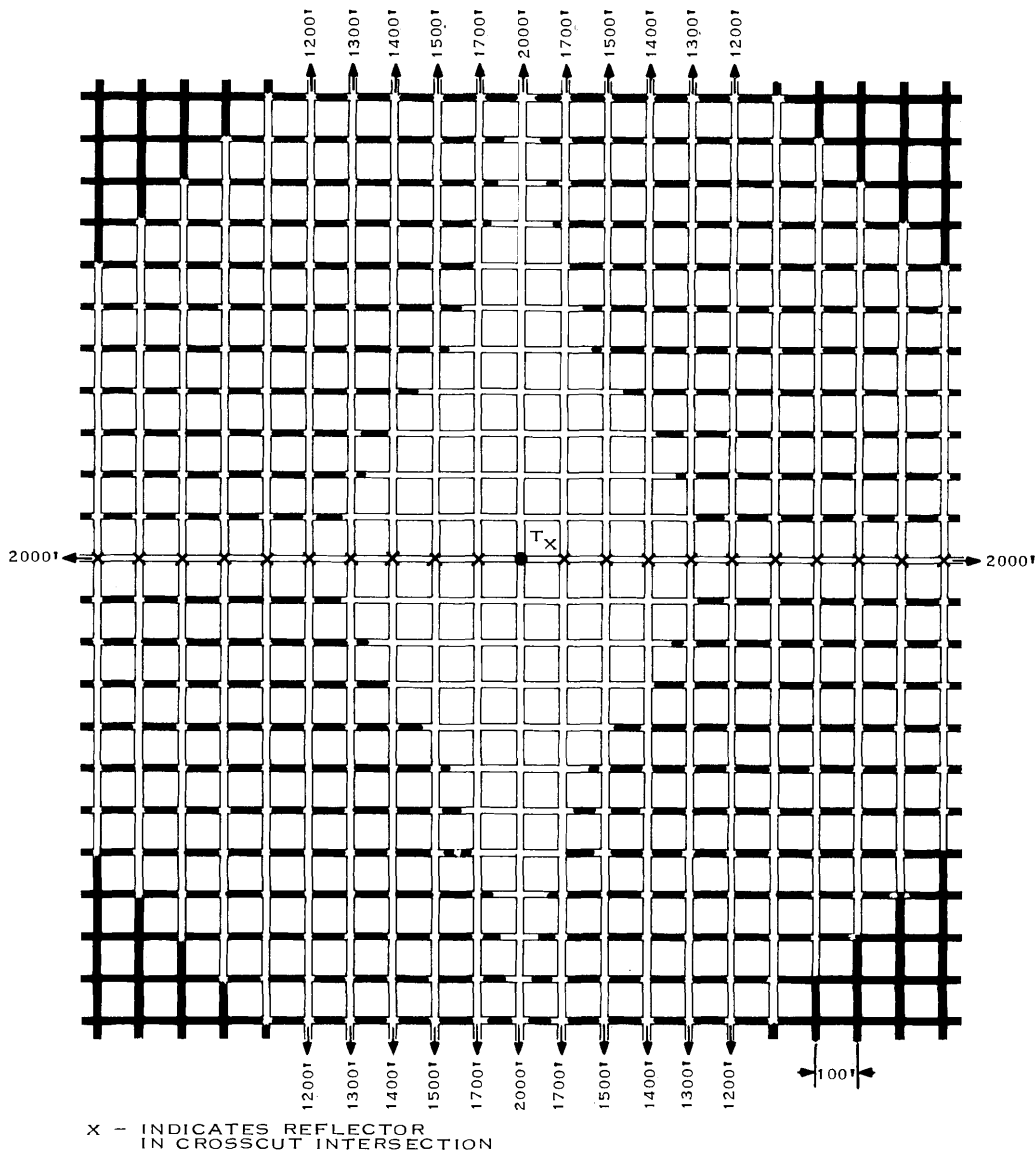

Figure 4-7. UHF Propagation (20-Watt Transceiver Transmitting to 1-Watt Transceiver With Reflectors - 2,000 ft).

Transmit frequency - 415 MHz

Polarization - Horizontal

Base station - 20-watt transceiver

Portable station - 1-watt transceiver

System range - 157 dB

Antenna - Omnidirectional, horizontal polarization, turnstyle

Reflector gain over isotropic - 24 dB

(Darkened area indicates loss of transmission)

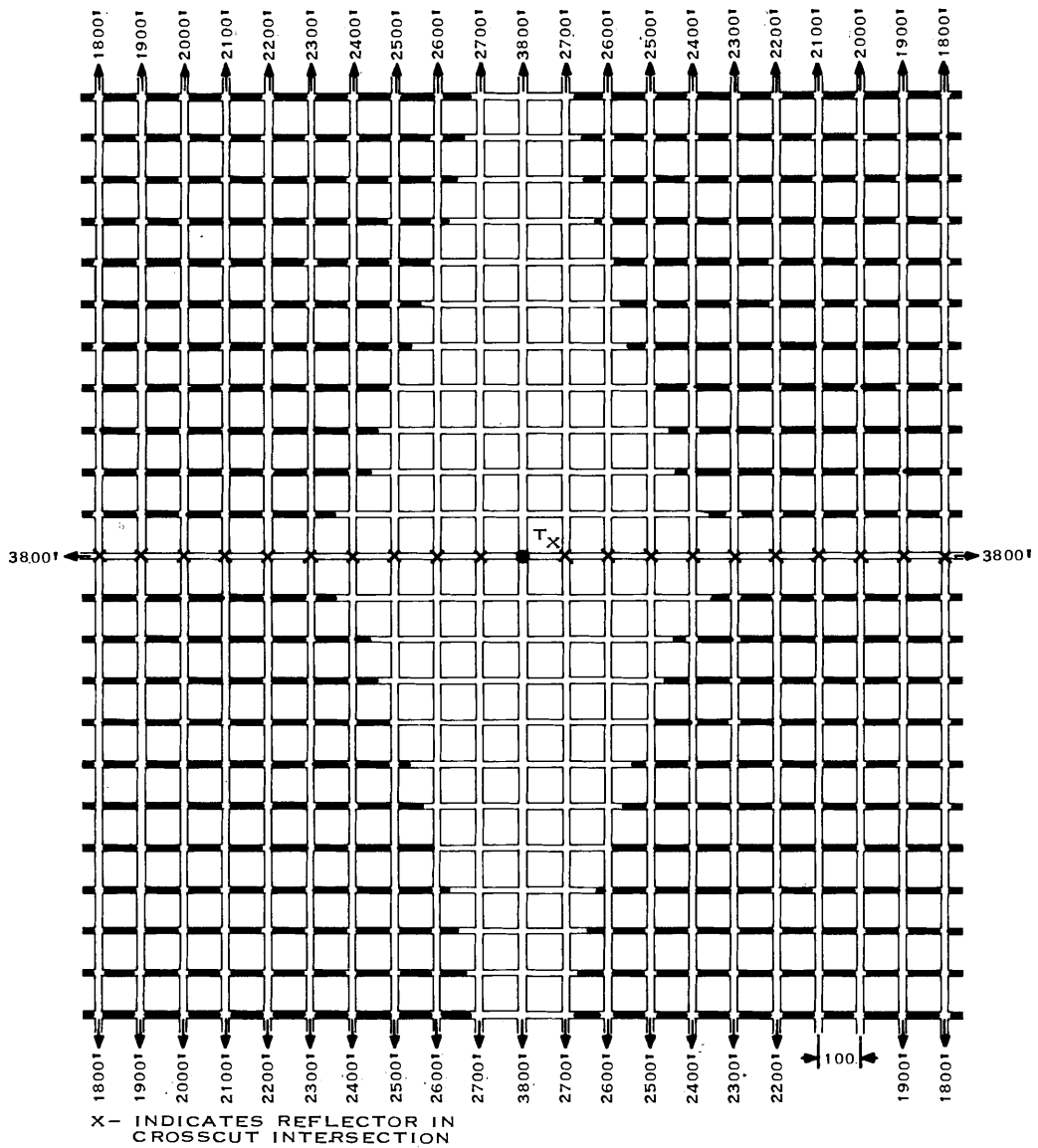

Figure 4-8. UHF Propagation (20-Watt Transceiver Transmitting to 1-Watt Transceiver With Corner Reflectors - 3,800 ft).

Transmit frequency - 1 GHz

Polarization - Horizontal

Base station - 20-watt transceiver

Portable station - 1-watt transceiver

System range - 157 dB

Antenna - Omnidirectional, horizontal polarization, turnstyle.

Reflector gain over isotropic - 24 dB

(Darkened area indicates loss of transmission)

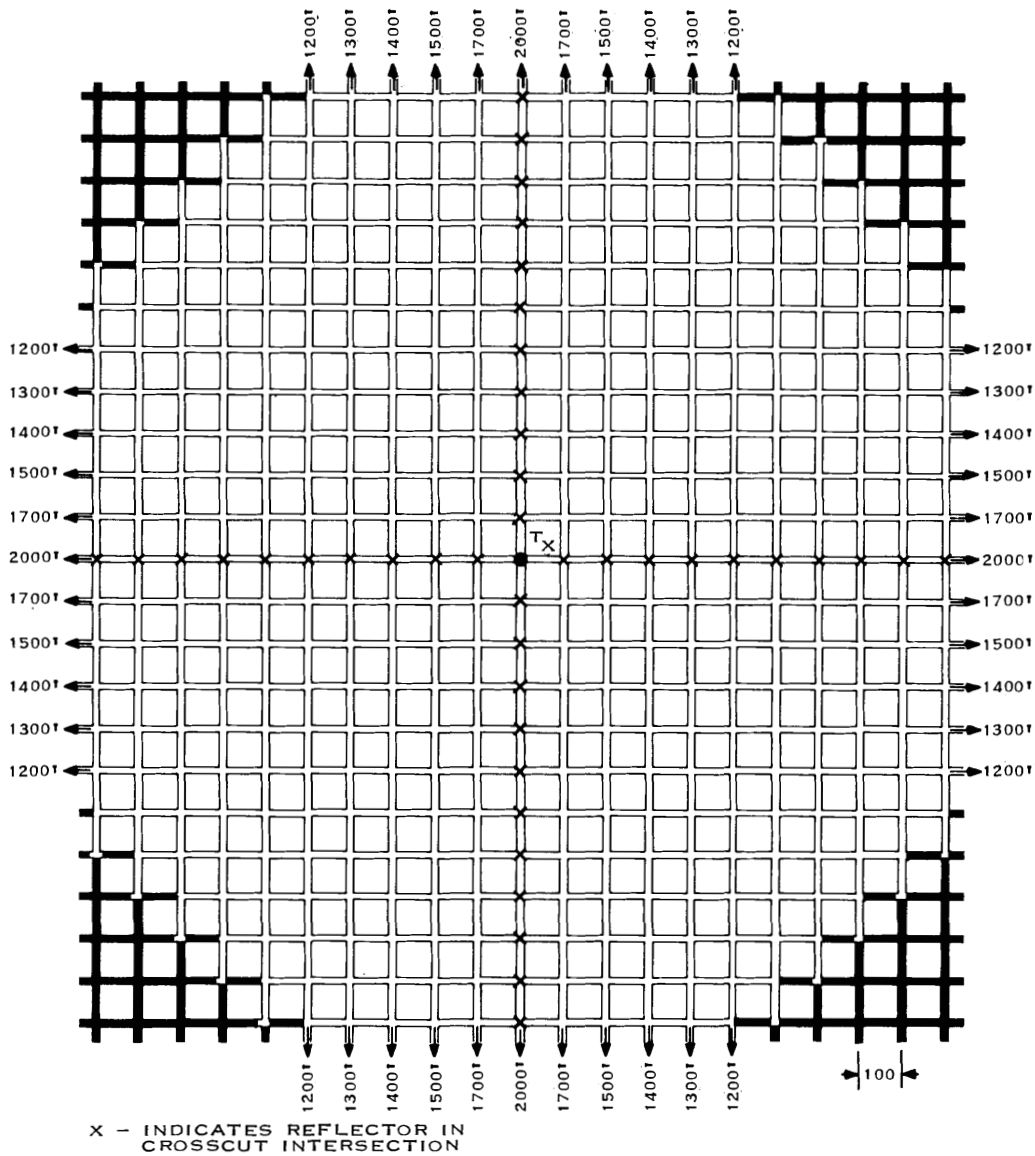

Figure 4-9. UHF Propagation (20-Watt Transceiver Transmitting to 1-Watt Transceiver With Corner Reflectors - 2,000 ft).

Transmit frequency - 415 MHz

Polarization - Horizontal

Base station - 20-watt transceiver

Portable station - 1-watt transceiver

System range - 157 dB

Antenna - Omnidirectional, horizontal polarization, turnstyle

Reflector gain of isotropic - 24 dB

(Darkened area indicates loss of transmission)

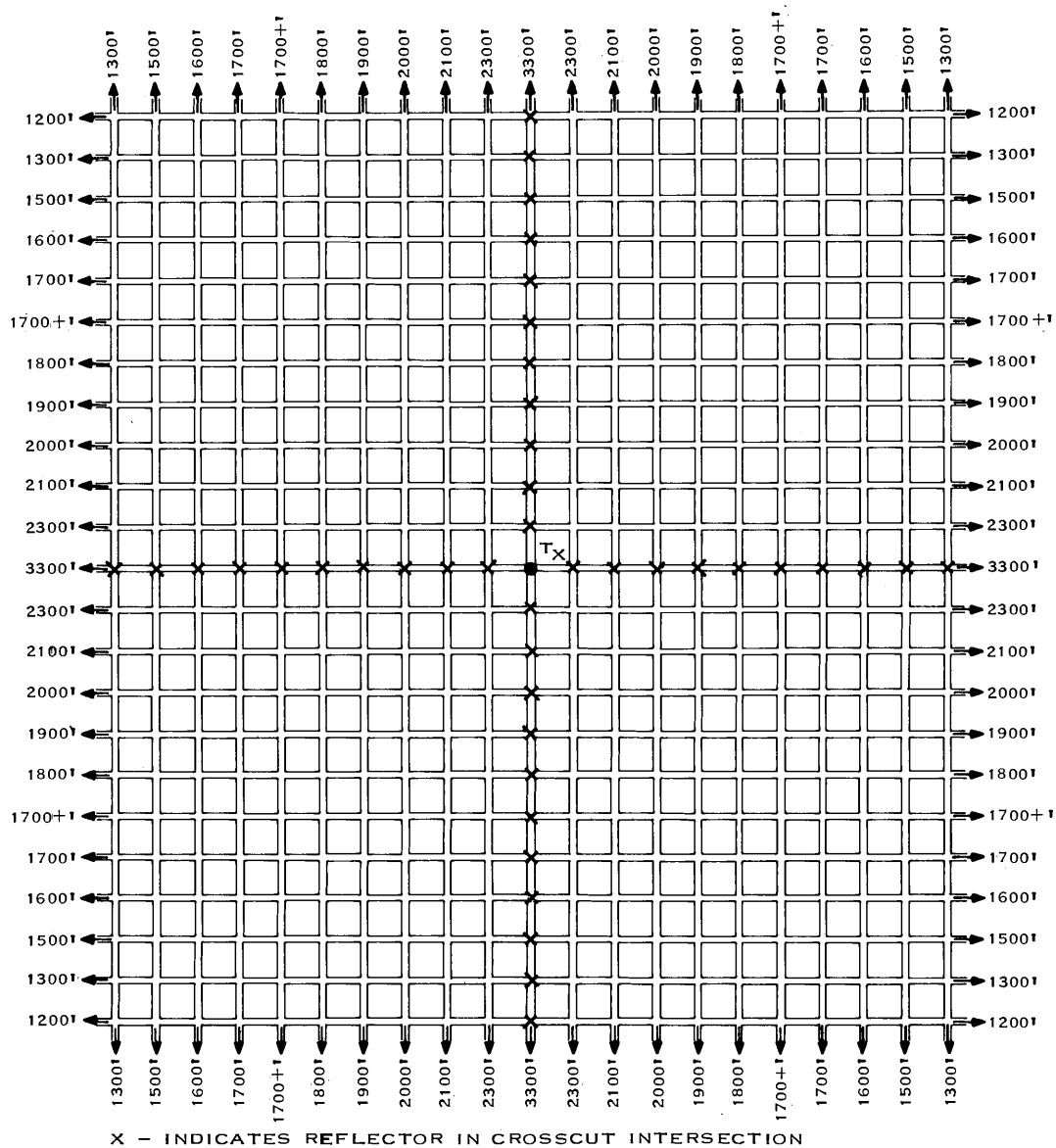

Figure 4-10. UHF Propagation (1-Watt Transceiver Transmitting to 1-Watt Transceiver With Corner Reflectors - 3,300 ft).

Transmit frequency - 1 GHz

Polarization - Horizontal

Base station - 1-watt transceiver

Portable station - 1-watt transceiver

System range - 144 dB

Antenna - Omnidirectional, horizontal polarization, turnstyle

Reflector gain above isotropic - 24 dB

(Darkened area indicates loss of transmission)

---

Test Equipment and Experimental Setups



This appendix lists the specific test equipments and configurations used during the coal mine field measurement program. Each item of standard test equipment carried a valid calibration sticker from Collins test equipment labs. Specific items built for this program, such as the vlf preamplifier and rf coaxial test leads were calibrated in Collins engineering lab prior to field use.

Table A-1 indicates the various items of equipment used to accomplish each test. Figures A-1 and A-2 show the associated equipment configurations for uhf and vlf, respectively. Figure A-3 shows the antenna complement, left to right: 200-, 415-, and 1000-MHz ground-plane antennas; 415-MHz corner reflectors; 200- and 415/1000-MHz dipoles; 1/3/10- and 20/50-kHz loops. Figure A-4 shows a close-up view of the 415-MHz corner reflector assembly.

Specifications for the vlf preamplifier are as follows:

Bandwidth (3 dB): 1 to 60 kHz  
Gain: 20 dB, nominal at 5 kHz  
Input:  $51\Omega$  or  $10\text{ k}\Omega$ , balanced or unbalanced  
60-Hz rejection: Greater than 30 dB  
Power: +12 and -12 Vdc, 5 mA

Design of the 415-MHz corner reflectors follows that given by Jasik.\*

Antenna parameters are as follows:

Center frequency: 415 MHz  
Corner angle: 90 degrees  
Reflector size:  $h=0.6\lambda$  (17 in)  
 $l=0.7\lambda$  (20 in)  
Dipole to corner spacing:  $s=0.35\lambda$  (9 7/8 in)  
Predicted gain: 12 dBi

The complete corner reflector assembly consists of two identical corner reflectors connected back -to-back physically and electrically. In this manner, the available power from one antenna will be reradiated by the other antenna in a direction at 90 degrees to the original signal. The effective reradiated power is  $2 \times 12 = 24$  dB above that reradiated by a matched isotropic antenna, equivalent to a plane reflector of  $1.3\lambda$  \*\* projected area. The maximum projected area of the corner reflector assembly is  $0.6\lambda$  \*\* hence the corner reflector approach results in a physical structure of approximately half the area of a plane reflecting surface.

Figure A-5 is an extended curve of the corner attenuation for uhf transmission at frequencies of 415 MHz and 1 GHz. Since measured values only extended to 120 feet, attenuation at greater distances was predicted. It was assumed that after rounding a corner, the attenuation of the electromagnetic wave would once again approach that of straight tunnel attenuation; that is 2.8 dB/100 ft for 1 GHz and 6 dB/100 ft for 415 MHz. This graph was used in the preparation of the uhf predictions. More study of corner attenuation is necessary before actual curves can be drawn.

---

\*Jasik, Henry, "Antenna Engineering Handbook," McGraw-Hill, New York, 1961, Chapter 11.

\*\*Jasik, Henry, "Antenna Engineering," McGraw-Hill, New York, 1961, Chapter 13.

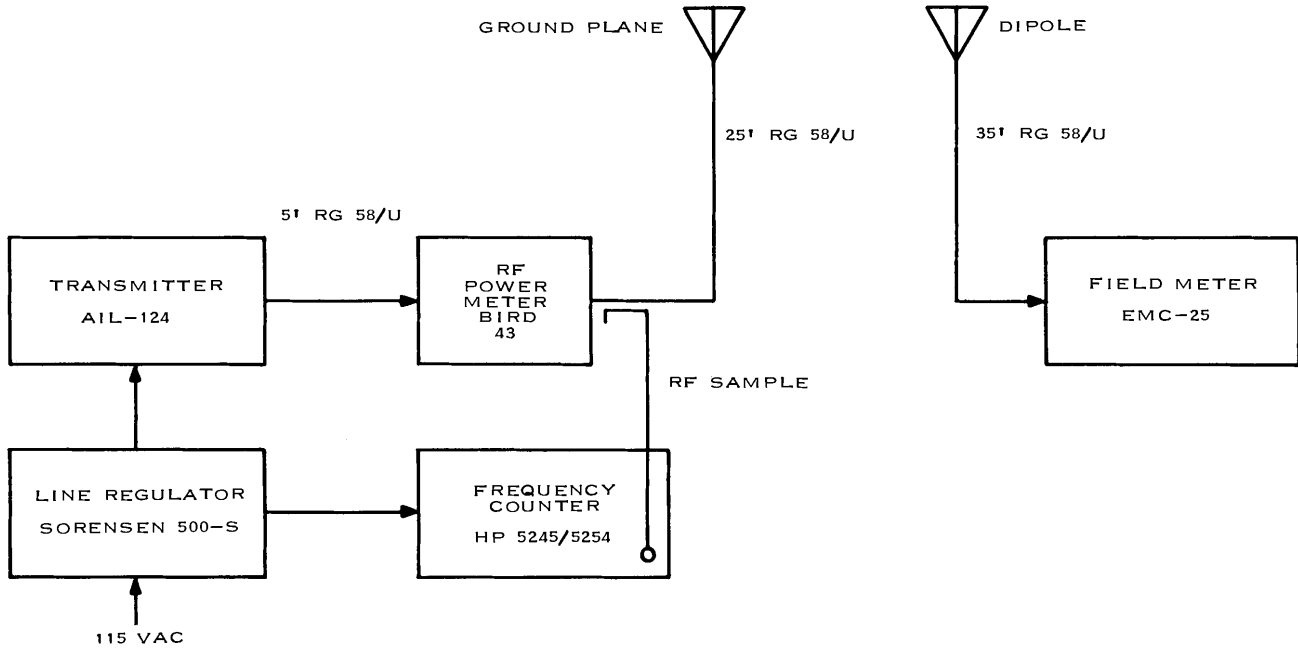

Figure A-1. UHF Test Setup.

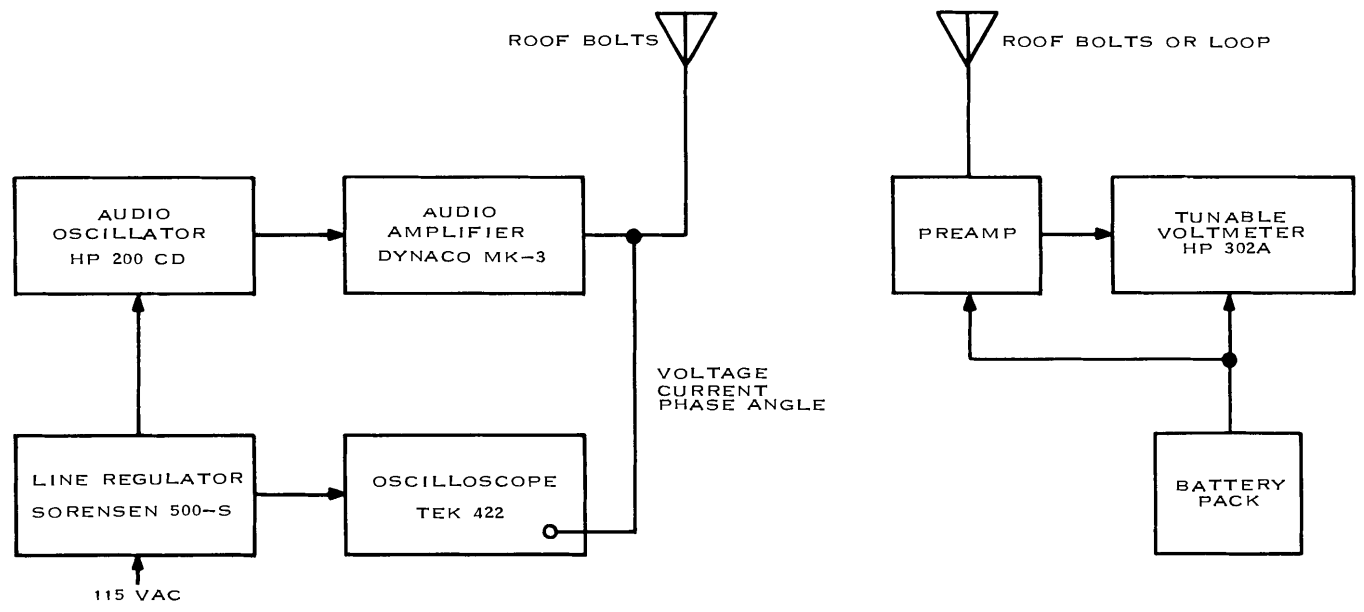

Figure A-2. VLF Test Setup.

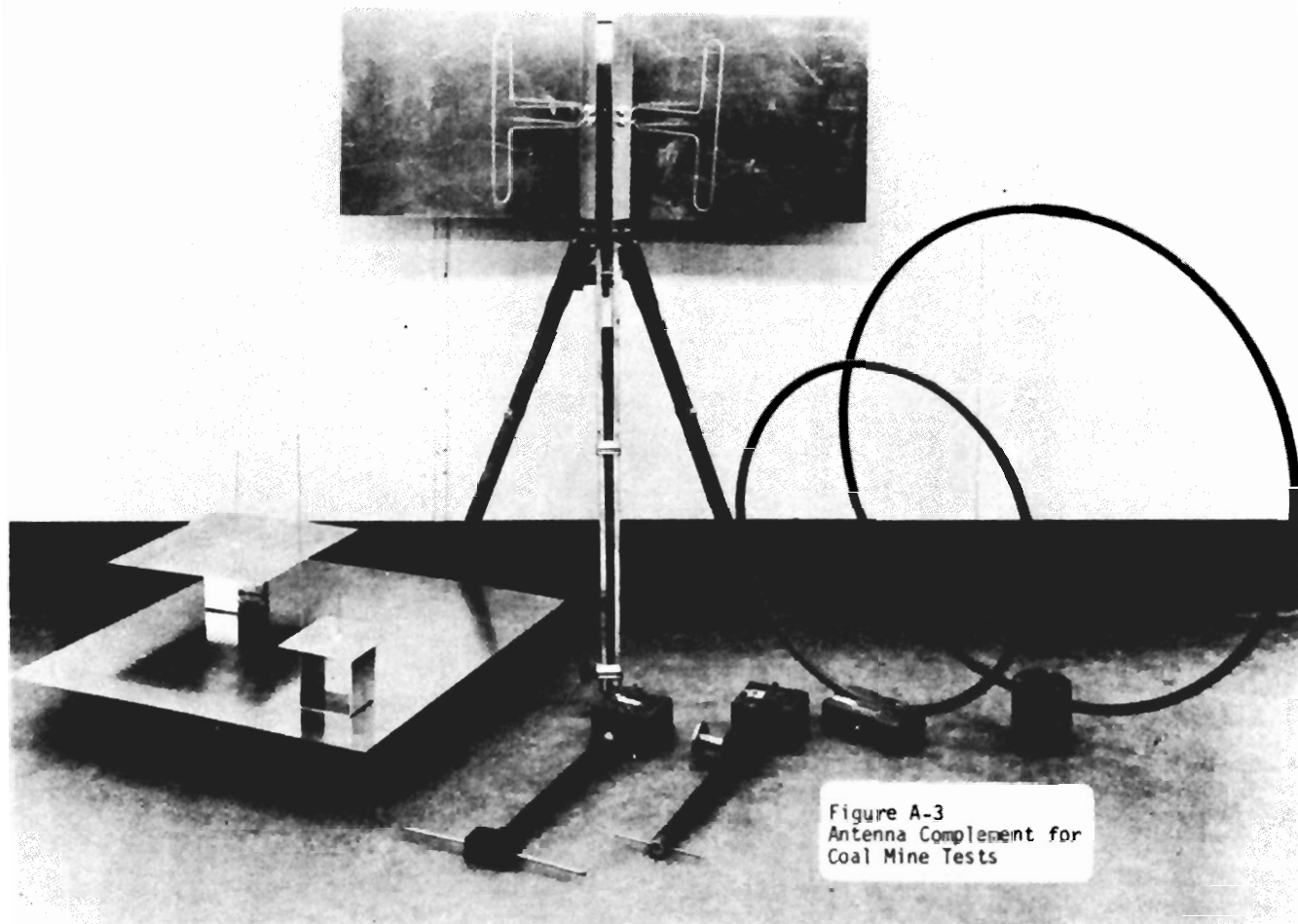

Figure A-3. Antenna Complement for Coal Mine Tests.

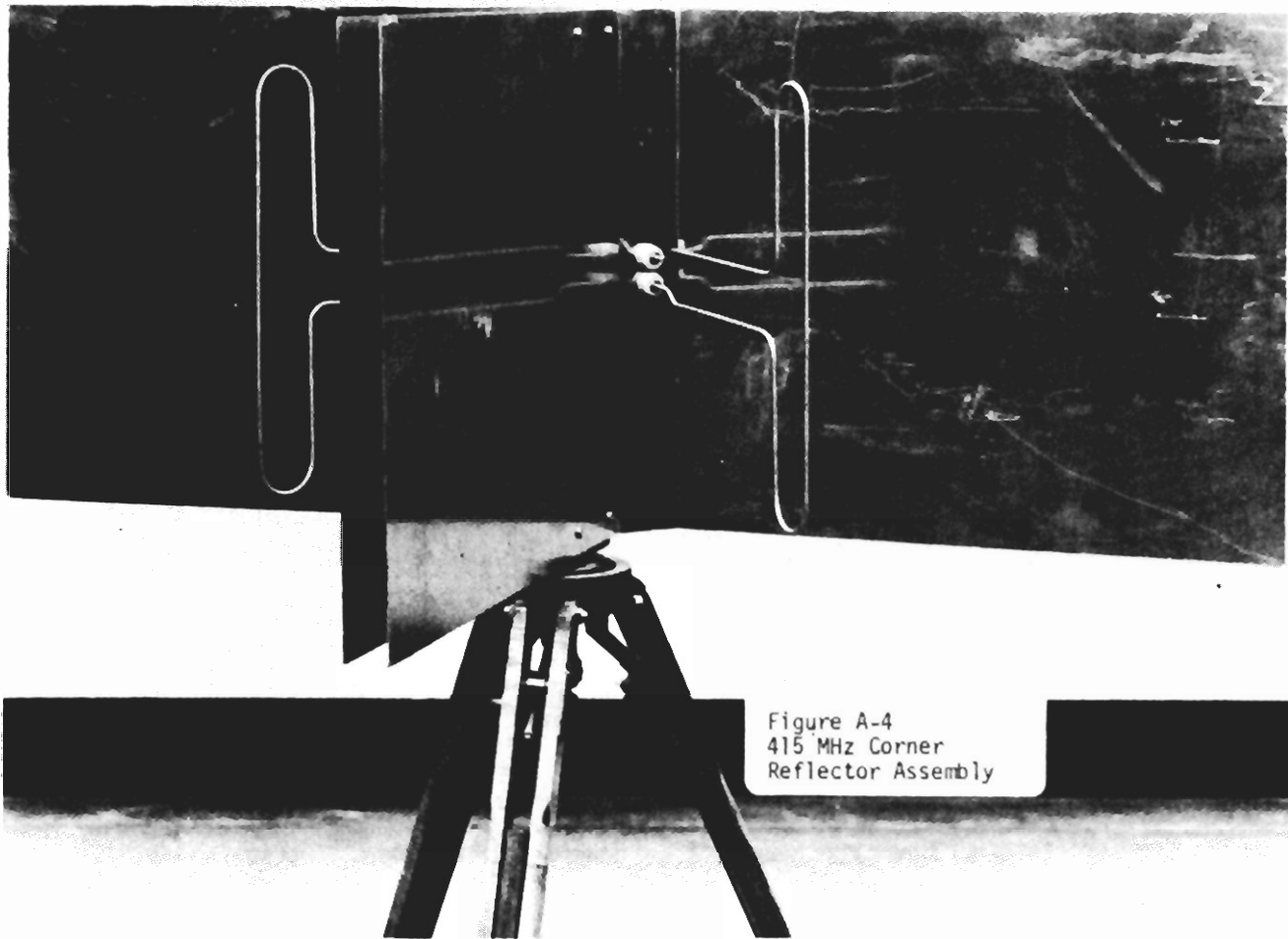

Figure A-4. 415-MHz Corner Reflector Assembly.

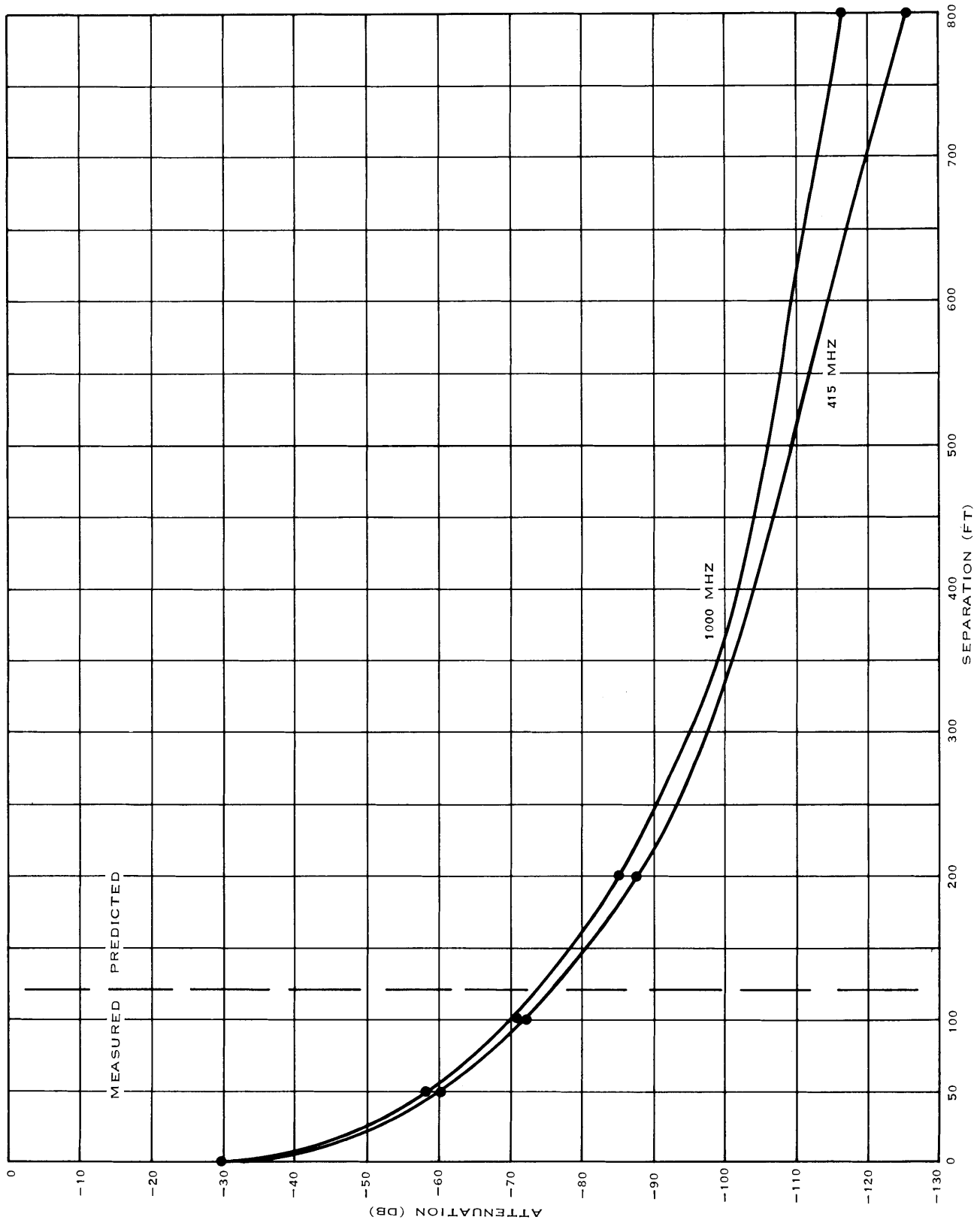

Figure A-5. Corner Attenuation Curves for Coverage Predictions.

Table A-1. Test Equipment List.

| ITEM  | UHF SIGNAL<br>ATTENUATION<br>AND NOISE | VLF SIGNAL<br>ATTENUATION<br>AND NOISE |
|---|--|--|
| Power Oscillator<br>AIL-124   | X                                      |  |
| RF Power Meter<br>BIRD 43   | X                                      |  |
| Frequency Counter<br>HP 5254L/5254C   | X                                      |  |
| Field Meter<br>EMC-25   | X                                      |  |
| Audio Oscillator<br>HP-200 CD   |  | X                                      |
| Audio Amplifier<br>DYNACO MK-3  |  | X                                      |
| Oscilloscope<br>TEKTRONIX 422   |  | X                                      |
| Tunable Voltmeter<br>HP 302A  |  | X                                      |
| VLF Preamplifier<br>COLLINS   |  | X                                      |
| A-C Line Stabilizer<br>SORENSEN 500-S                                       | X                                      | X                                      |
| Dipole Antennas<br>EMPIRE DM105-T2<br>DM105-T3                              | X                                      |  |
| Coaxial Log Spiral<br>STODDART 93490-1                                      | X                                      |  |
| $\lambda/4$ Groundplane<br>COLLINS  | X                                      |  |
| Loop Antennas<br>EMPIRE LG-105 (20/50 kHz)<br>FAIRCHILD ALP-10 (1/3/10 kHz) |  | X                                      |

Appendix B

---

Tables

This appendix contains the actual measurements relating to frequency, voltage, current, noise, and signal-plus-noise readings obtained in the Robena Mine for the various antenna arrangements noted in Section 3.

Table B-1. Roof-Bolt Transmitter, 8-Inch Receiver Loop.

| FREQ<br>(kHz)       | V<br>(volts) | A<br>(amperes) | NOISE<br>( $\mu$ V) | S+N<br>( $\mu$ V) | (S+N)/N | (S+N)/N<br>(dB) | P<br>(watts) |
|---------------------|--------------|----------------|---------------------|-------------------|---------|-----------------|--------------|
| 50-Foot Separation  |              |                |                     |                   |         |                 |              |
| 5                   | 25           |                | 13.0                | 19                | 1.4615  | 3.296           | 1.01         |
| 7                   | 25           |                | 10.0                | 25                | 2.5     | 7.96            | 1.04         |
| 10                  | 25           |                | 7.0                 | 25                | 3.57    | 11.057          | 1.08         |
| 20                  | 25           |                | 5.0                 | 21                | 4.2     | 12.465          | 1.18         |
| 50                  | 25           |                | 2.2                 | 110               | 50.0    | 33.98           | 1.23         |
| 70                  | 25           |                | 1.0                 | 150               | 150.0   | 43.52           | 1.29         |
| 100                 | 25           |                | 1.0                 | 180               | 180.0   | 45.105          | 1.30         |
| 200                 | 25           | .1             | Meter<br>noise      | 330               |         |                 | 1.46         |
| 100-Foot Separation |              |                |                     |                   |         |                 |              |
| 5                   | 25           |                | 3.8                 | 6.2               | 1.63    | 4.252           | 1.01         |
| 7                   | 25           |                | 3.6                 | 8.5               | 2.361   | 7.462           | 1.04         |
| 10                  | 25           |                | 4.8                 | 5.5               | 1.146   | 1.182           | 1.08         |
| 20                  | 25           |                | 4.5                 | 7.3               | 1.622   | 4.202           | 1.18         |
| 50                  | 25           |                | 1.6                 | 11.0              | 6.875   | 16.745          | 1.23         |
| 70                  | 25           |                | 0.9                 | 12.3              | 13.66   | 22.713          | 1.29         |
| 100                 | 25           |                | 0.8                 | 5.8               | 7.25    | 17.207          | 1.30         |
| 200                 | 25           | .1             | Meter<br>noise      | 1.2               |         |                 | 1.46         |
| 200-Foot Separation |              |                |                     |                   |         |                 |              |
| 5                   | 25           |                | 15.0                | --                |         |                 | 1.23         |
| 7                   | 25           |                | 11.5                | --                |         |                 | 1.23         |
| 10                  | 25           |                | 7.0                 | 7.4               | 1.057   | 0.481           | 1.23         |
| 20                  | 25           |                | 5.2                 | 5.5               | 1.058   | 0.487           | 1.23         |
| 50                  | 25           |                | 1.8                 | --                |         |                 | 1.23         |
| 70                  | 25           |                | 1.0                 | 1.1               | 1.1     | 0.828           | 1.6          |
| 100                 | 25           |                | 1.2                 | 1.3               | 1.083   | 0.695           | 1.3          |
| 200                 | 25           |                | 0.7                 | 6.0               | 8.57    | 18.66           | 2.5          |



Table B-1. Roof-Bolt Transmitter, 8-Inch Receive Loop (Cont).

| FREQ<br>(kHz)       | V<br>(volts) | A<br>(amperes) | NOISE<br>( $\mu$ V) | S+N<br>( $\mu$ V) | (S+N)/N | (S+N)/N<br>(dB) | P<br>(watts) |
|---------------------|--------------|----------------|---------------------|-------------------|---------|-----------------|--------------|
| 400-Foot Separation |              |                |                     |                   |         |                 |              |
| 5                   | 25           |                | --                  | --                | --      | --              |              |
| 7                   | 25           |                | --                  | --                | --      | --              |              |
| 10                  | 25           |                | --                  | --                | --      | --              |              |
| 20                  | 25           |                | --                  | --                | --      | --              |              |
| 50                  | 25           |                | 1.3                 | 1.3               | 1       | 0               | 1.23         |
| 70                  | 25           |                | 0.8                 | 0.85              | 1.0625  | 0.5266          | 1.6          |
| 100                 | 25           |                | 0.9                 | --                | --      | --              | 1.3          |
| 200                 | 25           |                | 0.5                 | 8.5               | 17      | 24.61           | 2.5          |

Table B-2. Large Loop Transmitters, 8-Inch Receive Loop.

| FREQ<br>(kHz)       | V<br>(volts) | A<br>(amperes) | NOISE<br>( $\mu$ V) | S+N<br>(mV)       | (S+N)/N  | (S+N)/N<br>(dB) | P<br>(watts) |
|---------------------|--------------|----------------|---------------------|-------------------|----------|-----------------|--------------|
| 50-Foot Separation  |              |                |                     |                   |          |                 |              |
| 5                   | 20           | 0.5            | 13                  | 8.1               | 623.08   | 55.89           | 10.0         |
| 7                   | 25           | 0.33           | 13                  | 8.2               | 630.77   | 56.00           | 8.25         |
| 10                  | 17           | 0.55           | 7                   | 13                | 1857.14  | 65.38           | 9.35         |
| 20                  | 23           | 0.48           | 5                   | 17                | 3400     | 70.63           | 11.04        |
| 50                  | 25           | 0.42           | 2.2                 | 29                | 13181.82 | 82.40           | 10.5         |
| 70                  | 25           | 0.37           | 1                   | 32                | 32000    | 90.10           | 9.25         |
| 100                 | 25           | 0.3            | 1                   | 32                | 32000    | 90.10           | 7.5          |
| 200                 | 25           | 0.46           | Meter<br>noise      | 30.5              |          |                 | 11.5         |
| 100-Foot Separation |              |                |                     |                   |          |                 |              |
| 5                   | 20           | 0.5            | 3.8                 | ( $\mu$ V)<br>360 | 94.74    | 39.53           | 10.0         |
| 7                   | 25           | 0.38           | 3.6                 | 370               | 102.78   | 40.237          | 10.0         |
| 10                  | 17           | 0.57           | 4.8                 | 620               | 129.17   | 42.22           | 9.69         |
| 20                  | 23           | 0.48           | 4.6                 | 930               | 202.17   | 46.114          | 11.04        |
| 50                  | 25           | 0.42           | 1.6                 | 1550              | 968.75   | 59.72           | 10.5         |
| 70                  | 25           | 0.37           | 0.9                 | 1640              | 1822.2   | 65.212          | 9.25         |
| 100                 | 25           | 0.3            | 0.8                 | 1460              | 1825.0   | 65.23           | 7.5          |
| 200                 | 25           | 0.46           | Meter<br>noise      | 1100              |          |                 | 11.5         |

Table B-2. Large Loop Transmitters, 8-Inch Receive Loop (Cont).

| FREQ<br>(kHz)       | V<br>(volts) | A<br>(amperes) | NOISE<br>( $\mu$ V) | S+N<br>(mV)      | (S+N)/N | (S+N)/N<br>(dB) | P<br>(watts) |
|---------------------|--------------|----------------|---------------------|------------------|---------|-----------------|--------------|
| 200-Foot Separation |              |                |                     |                  |         |                 |              |
| 5                   | 20           | 0.5            | 15.0                | ( $\mu$ V)<br>50 | 3.33    | 10.458          | 10.0         |
| 7                   | 25           | 0.38           | 11.5                | 49               | 4.26    | 12.59           | 10.0         |
| 10                  | 17           | 0.57           | 7.0                 | 76               | 10.857  | 20.71           | 9.69         |
| 20                  | 23           | 0.48           | 5.2                 | 98               | 18.846  | 25.5            | 11.04        |
| 50                  | 25           | 0.42           | 1.8                 | 100              | 55.56   | 34.89           | 10.5         |
| 70                  | 25           | 0.37           | 1.0                 | 85               | 85.0    | 38.588          | 9.25         |
| 100                 | 25           | 0.3            | 1.2                 | 60               | 50.0    | 33.979          | 7.5          |
| 200                 | 25           | 0.46           | Meter<br>noise      | 13               |         |                 | 11.5         |
| 400-Foot Separation |              |                |                     |                  |         |                 |              |
| 5                   | 20           | 0.5            | --                  | ( $\mu$ V)<br>-- | --      | --              | 10.0         |
| 7                   | 25           | 0.38           | --                  | --               | --      | --              | 10.0         |
| 10                  | 17           | 0.57           | --                  | --               | --      | --              | 9.69         |
| 20                  | 23           | 0.48           | --                  | --               | --      | --              | 11.04        |
| 50                  | 25           | 0.42           | 1.3                 | 1.4              | 1.076   | 6.36            | 10.5         |
| 70                  | 25           | 0.37           | 0.8                 | 2.4              | 3.0     | 9.54            | 9.25         |
| 100                 | 25           | 0.3            | 0.9                 | 2.5              | 2.78    | 8.874           | 7.5          |
| 200                 | 25           | 0.46           | 0.5                 | 2.2              | 4.4     | 12.87           | 11.5         |



Table B-4. Roof-Bolt and Large-Loop Transmission.

(Compensation for 200-Hz to 1-Hz Bandwidth and Normalized to 10 Watts Input Power).

| FREQUENCY         | (50FT)<br>NORMALIZED<br>(S+N)/N (dB) | (100 FT)<br>NORMALIZED<br>(S+N)/N (dB) | (200 FT)<br>NORMALIZED<br>(S+N)/N (dB) | (400 FT)<br>NORMALIZED<br>(S+N)/N (dB) |
|-------------------|--------------------------------------|--|--|--|
| Root-Bolt Source  |                                      |  |  |  |
| 5                 | 35.396                               | 36.35                                  | -                                      | -                                      |
| 7                 | 40.06                                | 39.56                                  | -                                      | -                                      |
| 10                | 43.167                               | 33.28                                  | 32.58                                  | -                                      |
| 20                | 44.565                               | 36.302                                 | 32.59                                  | -                                      |
| 50                | 66.08                                | 48.845                                 | -                                      | 32.1                                   |
| 70                | 74.48                                | 53.09                                  | 32.56                                  | 31.48                                  |
| 100               | 76.96                                | 49.07                                  | 32.56                                  | -                                      |
| 200               |                                      |  | 50.00                                  | 45.32                                  |
| Large-Loop Source |                                      |  |  |  |
| 5                 | 78.87                                | 62.51                                  | 33.44                                  | -                                      |
| 7                 | 79.833                               | 63.46                                  | 35.81                                  | -                                      |
| 10                | 88.68                                | 65.36                                  | 43.85                                  | -                                      |
| 20                | 93.2                                 | 68.68                                  | 48.07                                  | -                                      |
| 50                | 105.19                               | 82.51                                  | 57.68                                  | 29.14                                  |
| 70                | 113.44                               | 88.55                                  | 61.93                                  | 32.88                                  |
| 100               | 114.35                               | 89.48                                  | 58.23                                  | 33.12                                  |
| 200               |                                      |  |  | 35.81                                  |

Table B-5. 8-Inch Transmit Loop Normalized to 10-W, 1-Hz Bandwidth.

| LARGE LOOP         |                | ROOF BOLT                 |
|--------------------|----------------|---------------------------|
| FREQ (kHz)         | (S + N)/N (dB) | NORMALIZED (S + N)/N (dB) |
| 50-Foot Separation |                |                           |
| 5                  | 56.03          | 46.65                     |
| 7                  | 70.12          | 33.46                     |
| 10                 | 73.12          | 32.44                     |
| 20                 | -              | -                         |
| 50                 | 92.86          | 62.65                     |
| 70                 | 90.25          | 44.94                     |
| 100                | 107.97         | 53.43                     |

Table B-5. 8-Inch Transmit Loop Normalized to 10-W, 1-Hz Bandwidth (Cont).

| LARGE LOOP                           |                  | ROOF BOLT                       |
|--------------------------------------|------------------|---------------------------------|
| FREQ (kHz)                           | (S + N)/N (dB)   | NORMALIZED (S + N)/N (dB)       |
| 100-Foot Separation                  |                  |                                 |
| 5                                    | 33.30            | -                               |
| 7                                    | 43.29            | 25.98                           |
| 10                                   | 45.14            | 24.16                           |
| 20                                   | -                | -                               |
| 50                                   | 83.60            | 51.06                           |
| 70                                   | 83.50            | 54.09                           |
| 100                                  | 96.06            | 64.37                           |
| To Large Loop - 100-Foot Separation  |                  |                                 |
| FREQ                                 | S + N (mV)       | S + N (NORMALIZED TO 10 W) (mV) |
| 5                                    | 0.1              | 0.2                             |
| 7                                    | 0.31             | 0.36                            |
| 10                                   | -                | -                               |
| 20                                   | -                | -                               |
| 50                                   | 2.05             | 2.37                            |
| 70                                   | 2.2              | 4.23                            |
| 100                                  | -                | -                               |
| To Line Source - 100-Foot Separation |                  |                                 |
| FREQ                                 | S + N ( $\mu$ V) | S + N (NORMALIZED TO 10 W) (mV) |
| 5                                    | -                | -                               |
| 7                                    | 0.350            | 0.41                            |
| 10                                   | -                | 0.277                           |
| 20                                   | -                | -                               |
| 50                                   | 0.35             | 0.40                            |
| 70                                   | 0.43             | 0.83                            |
| 100                                  | -                | 1.081                           |

Table B-6. Large Loop Transmission.

| FREQ                | S + N (mV) | S + N (NORMALIZED TO 10 W) (mV) |
|---------------------|------------|---------------------------------|
| 50-Foot Separation  |            |                                 |
| 5                   | 8.1        | 8.1                             |
| 7                   | 8.2        | 9.03                            |
| 10                  | 13.0       | 13.44                           |
| 20                  | 17.0       | 16.18                           |
| 50                  | 29.0       | 28.30                           |
| 70                  | 32.0       | 33.27                           |
| 100                 | 32.0       | 36.95                           |
| 200                 | 30.5       | 28.44                           |
| 100-Foot Separation |            |                                 |
| 5                   | 360        | 360.0                           |
| 7                   | 401        | 401.0                           |
| 10                  | 620        | 629.84                          |
| 20                  | 930        | 885.11                          |
| 50                  | 1550       | 1512.65                         |
| 70                  | 1640       | 1705.0                          |
| 100                 | 1460       | 1686.0                          |
| 200                 | 1100       | 1025.76                         |
| 200-Foot Separation |            |                                 |
| 5                   | 50         | 50.0                            |
| 7                   | 53         | 53.0                            |
| 10                  | 76         | 77.21                           |
| 20                  | 98         | 93.27                           |
| 50                  | 100        | 98.0                            |
| 70                  | 85         | 88.39                           |
| 100                 | 60         | 69.28                           |
| 200                 | 113        | 12.37                           |
| 400-Foot Separation |            |                                 |
| 5                   | -          | -                               |
| 7                   | -          | -                               |
| 10                  | -          | -                               |
| 20                  | -          | -                               |
| 50                  | 1.4        | 1.37                            |
| 70                  | 2.4        | 2.50                            |
| 100                 | 2.5        | 2.89                            |
| 200                 | 2.2        | 2.05                            |

Table B-7. Roof-Bolt Transmission

| FREQ                | S + N ( $\mu$ V) | S + N (NORMALIZED TO 10 W) ( $\mu$ V) |
|---------------------|------------------|---------------------------------------|
| 50-Foot Separation  |                  |                                       |
| 5                   | 19               | 50.18                                 |
| 7                   | 25               | 76.28                                 |
| 10                  | 25               | 61.28                                 |
| 20                  | 21               | 59.88                                 |
| 50                  | 110              | 313.65                                |
| 70                  | 150              | 417.00                                |
| 100                 | 180              | 499.0                                 |
| 200                 | 330              | 862.51                                |
| 100-Foot Separation |                  |                                       |
| 5                   | 6.2              | 17.68                                 |
| 7                   | 8.5              | 24.24                                 |
| 10                  | 5.5              | 15.68                                 |
| 20                  | 7.3              | 20.81                                 |
| 50                  | 11.0             | 31.36                                 |
| 70                  | 12.3             | 34.75                                 |
| 100                 | 5.8              | 16.09                                 |
| 200                 | 1.2              | 2.4                                   |
| 200-Foot Separation |                  |                                       |
| 5                   | -                | -                                     |
| 7                   | -                | -                                     |
| 10                  | 7.4              | 21.10                                 |
| 20                  | 5.5              | 15.68                                 |
| 50                  | -                | -                                     |
| 70                  | 1.1              | 2.75                                  |
| 100                 | 1.3              | 3.61                                  |
| 200                 | 6.0              | 85.68                                 |
| 400-Foot Separation |                  |                                       |
| 50                  | 1.3              | 3.71                                  |
| 70                  | 0.85             | 2.13                                  |
| 200                 | 8.5              | 6.53                                  |

Table B-8. Small-Loop Transmission.

| FREQ                                | S + N (mV) | S + N (NORMALIZED TO 10 W) (mV) |
|-------------------------------------|------------|---------------------------------|
| To Large Loop - 50-Foot Separation  |            |                                 |
| 5                                   | 2.6        | 4.84                            |
| 7                                   | 8.6        | 9.07                            |
| 10                                  | 6.1        | 7.04                            |
| 20                                  | -          | -                               |
| 50                                  | 14.0       | 16.17                           |
| 70                                  | 9.0        | 16.43                           |
| 100                                 | 14.0       | 17.71                           |
| To Line Source - 50-Foot Separation |            |                                 |
| 5                                   | 3.5        | 6.54                            |
| 7                                   | 0.79       | 0.83                            |
| 10                                  | 0.59       | 0.68                            |
| 20                                  | -          | -                               |
| 50                                  | 1.33       | 1.54                            |
| 70                                  | 1.0        | 1.83                            |
| 100                                 | 2.1        | 2.66                            |