

February, 2020

NIOSH Manual of Analytical Methods (NMAM), 5th Edition

Editors: Ronnee Andrews, Ph.D. and Paula Fey O'Connor, NIOSH

[This document is current as of the publication date above and will be periodically updated. For the most current listing of methods and guidance chapters, please visit the NMAM website at www.cdc.gov/niosh/nmam.]



**Centers for Disease Control
and Prevention**
National Institute for Occupational
Safety and Health

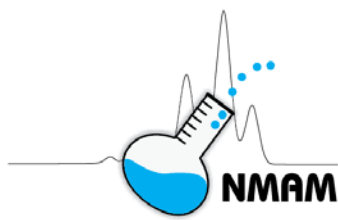

Foreword

The National Institute for Occupational Safety and Health (NIOSH) is the U.S. federal agency responsible for conducting research and making recommendations for the prevention of work-related injury and illness. NIOSH is part of the Centers for Disease Control and Prevention (CDC) in the U.S. Department of Health and Human Services. The NIOSH Manual of Analytical Methods (NMAM) is a compilation of validated sampling and analytical methods that are used globally for occupational exposure assessment in the industrial (occupational) hygiene field and related professions. The methods that are published in NMAM are evaluated and validated in consideration of their fitness-for-purpose for exposure monitoring in work areas. NIOSH methods primarily address workplace air sampling and analysis, but NMAM also includes protocols for biological, surface, dermal, and bulk samples. Within NMAM, but separate from the methods themselves, are assorted chapters providing background and guidance covering a number of subjects. Explanatory chapters on quality assurance, sampling guidance, method development and evaluation, aerosol collection, etc., provide valuable information to users of NIOSH methods. NMAM chapters provide a convenient resource that augments technical information often (but not always) available elsewhere in texts and monographs. Now in its fifth edition, NMAM is continuously updated as new or revised methods are evaluated and their performance verified.

This document is a compilation of its guidance chapters and methods, current as of the date shown on the front page. NMAM is published online on the NIOSH web page (www.cdc.gov/niosh/nmam) and is available worldwide free of charge. Users are encouraged to visit the NMAM 5th edition website for the most current methods and guidance chapters.



CHAPTERS

- PS - Purpose and Scope
- ME - Development and evaluation of methods
- UA - Measurement uncertainty and NIOSH method accuracy range
- SA - General considerations for sampling airborne contaminants
- AE - Factors affecting aerosol sampling
- BA - Sampling and characterization of bioaerosols
- FP - Filter pore size and aerosol sample collection
- FI - Measurement of fibers
- SM - Sampling and analysis of soluble metal compounds
- DL - Monitoring diesel particulate exhaust in the workplace
- CN - Analysis of carbon nanotubes and nanofibers on mixed cellulose ester filters by transmission electron microscopy
- GL - Glossary



METHODS

| | |
|--|---|
| 0501 - PARTICULATES N.O.R., Total | 7082 - LEAD by Flame AAS |
| 1453 - VINYL ACETATE | 7302 - ELEMENTS by ICP (Microwave Digestion) |
| 2005 - NITROAROMATIC COMPOUNDS | 7304 - ELEMENTS by ICP (Microwave Digestion) |
| 2008 - CHLOROACETIC ACID | 7306 - ELEMENTS by Cellulosic Internal Capsule Sampler |
| 2014 - <i>p</i> -CHLOROPHENOL | 7400 - ASBESTOS and OTHER FIBERS by PCM |
| 2016 - FORMALDEHYDE | 7405 - ALKALI METAL CATIONS Na ⁺ , K ⁺ , Li ⁺ |
| 2027 - KETONES | 7502 - ZINC OXIDE |
| 2514 - ANISIDINE | 7600 - CHROMIUM, HEXAVALENT |
| 2520 - METHYL BROMIDE | 7602 - SILICA, Respirable Crystalline, by IR (KBr pellet) |
| 2531 - GLUTARALDEHYDE | 7603 - QUARTZ in Respirable Coal Mine Dust, by IR (Redeposition) |
| 2536 - VALERALDEHYDE | 7605 - CHROMIUM, HEXAVALENT by Ion Chromatography |
| 3800 - ORGANIC & INORGANIC GASES by Extractive FTIR Spectrometry | 7701 - LEAD BY PORTABLE ULTRASONIC EXTRACTION/ASV |
| 3900 - Volatile Organic Compounds, C1 to C10, Canister Method | 7703 - CHROMIUM, HEXAVALENT by Field-Portable Spectrophotometry |
| 5004 - HYDROQUINONE | 7704 - BERYLLIUM in Air by Fluorometry |
| 5005 - THIRAM | 7906 - PARTICULATE FLUORIDES and HYDROFLUORIC ACID by Ion Chromatography |
| 5007 - ROTENONE | 7907 - VOLATILE ACIDS by Ion Chromatography |
| 5008 - PYRETHRUM | 7908 - NON-VOLATILE ACIDS - (Sulfuric Acid and Phosphoric Acid) |
| 5009 - BENZOYL PEROXIDE | 8007 - TOLUENE in Blood |
| 5016 - STRYCHNINE | 8200 - ELEMENTS in Tissues |
| 5022 - ARSENIC, organo- | 8308 - FLUORIDE in Urine |
| 5033 - <i>p</i> -NITROANILINE | 8318 - 2,5-HEXANEDIONE in Urine |
| 5040 - DIESEL PARTICULATE MATTER (as Elemental Carbon) | 8319 - ACETONE and METHYL ETHYL KETONE in Urine |
| 5100 - CARBON BLACK | 8320 - BUTYLTIN TRICHLORIDE in Urine |
| 5504 - ORGANOTIN COMPOUNDS (as Sn) | 8321 - <i>o</i> -CRESOL in Urine |
| 5509 - BENZIDINE and 3,3'-DICHLOROBENZIDINE | 8322 - TRICHLOROACETIC ACID IN Urine |
| 5524 - METALWORKING FLUIDS (MWF) ALL CATEGORIES | 8324 - 3-BROMOPROPIONIC ACID in Urine |
| 5526 - METHYLTIN CHLORIDES | 8326 - S-BENZYL MERCAPTURIC ACID AND S-PHENYLMERCAPTURIC ACID IN Urine |
| 5600 - ORGANOPHOSPHORUS PESTICIDES | 9000 - ASBESTOS, CHRYSOTILE by XRD |
| 5601 - ORGANONITROGEN PESTICIDES | 9106 - METHAMPHETAMINE and Illicit Drugs, Precursors and Adulterants on Wipes by Liquid-Liquid Extraction |
| 5700 - FORMALDEHYDE ON DUST (TEXTILE OR WOOD) | 9109 - METHAMPHETAMINE and Illicit Drugs, Precursors and Adulterants on Wipes by Solid-Phase Extraction |
| 6001 - ARSINE | 9110 - BERYLLIUM in Surface Wipes by Fluorometry |
| 6002 - PHOSPHINE | 9111 - METHAMPHETAMINE on Wipes by LC/MS |
| 6010 - HYDROGEN CYANIDE | |
| 6012 - SULFURYL FLUORIDE | |
| 6016 - AMMONIA by IC | |
| 6604 - CARBON MONOXIDE | |

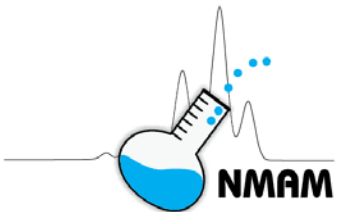

CHAPTERS



NIOSH Manual of Analytical Methods (NMAM), 5th Edition

Purpose, Scope and Use of the NIOSH Manual of Analytical Methods

by Kevin Ashley, Ph.D. and Paula Fey O'Connor, NIOSH

| | | |
|---|-------------------|------|
| 1 | Purpose and scope | PS-2 |
| 2 | How to use NMAM | PS-3 |
| 3 | References | PS-8 |



**Centers for Disease Control
and Prevention**
National Institute for Occupational
Safety and Health



1 Purpose and scope

The health of working people in myriad industries and occupations is potentially at risk through workplace exposure to airborne chemical and biological agents [Hathaway and Proctor 2004; Rose and Cohrsen 2011; Eduard et al. 2012; Jakubowski 2012]. Commonly it is the responsibility of occupational hygienists and often other public health professionals to determine the effectiveness of measures taken to minimize and control worker exposures to airborne toxins and toxicants, and this is normally achieved by monitoring workplace air quality [DiNardi 2003; Vincent 2007, 2012; Kulkarni et al. 2011]. Air monitoring is vital because inhalation is ordinarily the most likely route of exposure in occupational settings. Frequently other routes of workplace exposure, notably dermal contact with chemical and biological agents, must also be considered [Semple and Cherrie 2003; Brisson and Ashley 2011; Behroozy 2013]. Complementary biomonitoring methods are also often used to assess occupational exposures to toxic chemical compounds through measurement of specific analytes, e.g., metabolites and/or biomarkers, in body fluids (normally blood and urine) and tissues [Angerer and Greim 2006].

The *NIOSH Manual of Analytical Methods* (NMAM) is a compilation of analytical methods for air, biological, surface (including dermal) and bulk samples that have been evaluated and validated in consideration of their fitness for purpose for workplace exposure monitoring [NIOSH 1995]. NIOSH sampling and analytical methods are intended to promote accuracy, sensitivity, and specificity in industrial hygiene analyses and related applications. NMAM, which is published online (available at: www.cdc.gov/niosh/nmam), is constantly updated as new methods are developed and validated and as revised methods are evaluated and their performance verified. The methods published in NMAM are relied upon by authoritative bodies such as accrediting organizations and regulatory agencies. Besides sampling and analytical methods, NMAM also includes chapters on quality assurance, portable instrumentation, measurement of fibers, aerosol sampler design, and other guidance on specific areas of interest.

Often there are situations during use where certain NIOSH methods may require modification, for instance, to accommodate interfering compounds from a particular workplace, to take advantage of unique laboratory capabilities, to make use of equivalent sample preparation or analysis techniques, or to make possible the analysis of a single sample for multiple contaminants. When method modifications are made, quality control data demonstrating the reliability of the modified method must be obtained, recorded and reported. Examples where method modifications might be required include the following:

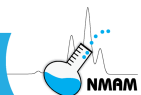

- The volume of air sampled on solid sorbents should be reduced in cases of high vapor concentration or high humidity and, in some cases, may be increased if such concentrations are relatively low.
- Automation of sample preparation and measurement procedures usually requires modification of the manual procedure on which the modified method is based.
- Chromatographic conditions, including choice of column and detector, can be modified to eliminate interferences or increase sensitivity during measurement.
- Acid mixtures used for sample dissolutions for elemental analysis may require modification for certain sample matrices that are difficult to dissolve.

For the measurement of each analyte or group of analytes of concern in workplace environmental samples or in biological specimens obtained from workers, it is desired to produce sampling and analytical methods that will meet the needs of field investigators (e.g., industrial hygienists, control engineers or occupational physicians) as well as laboratory personnel (e.g., analytical chemists, biochemists, epidemiologists or toxicologists). Many NIOSH methods are developed in parallel with related voluntary consensus standards [Ashley 2015]. The ultimate goal of the formalized NIOSH method development, evaluation and validation protocol is to make available sampling and analytical methods for applications in the occupational hygiene arena that are fit for purpose, analytically rigorous, and adequately ruggedized.

2 How to use NMAM

NIOSH methods are grouped alphabetically by method name, and some method names may refer to a group of related substances. It is also possible to locate methods through their arrangement by method number. Methods for particular analytes or groups of analytes can additionally be accessed by searching their Chemical Abstracts Service (CAS) number(s) through the online link.

a. Locating a NIOSH method

Often the easiest and fastest way to locate a method is to refer to the online method index, which contains an alphabetical listing of analytes and listing by method number. Each method's cover page contains information on alternate chemical names and information on: Compound(s), Method Number, Method Name, Sampling Rate, Minimum Volume, Maximum Volume, Reagents, Analytical Technique and Sampler (for a quick reference). It is also possible to search electronically by method number and/or CAS number (if known).



b. Method numbering system

The general NMAM method numbering system is outlined in the table below. Substances having the same sampling device, sample preparation procedure and measurement technique are often grouped together in one method (e.g., organic vapors; metals).

| Method No. | Substances |
|-------------------|--|
| 0001-0799 | General air samples |
| 0800-0999 | Bioaerosols |
| 1000-1999 | Organic vapors on charcoal sorbents |
| 2000-3499 | Organic vapors on other solid sorbents |
| 3500-3999 | Organic vapors on other samplers (e.g., liquids; direct-reading instruments) |
| 4000-4999 | Organic vapors on diffusive samplers |
| 5000-5999 | Organic aerosols |
| 6000-6999 | Inorganic gases and vapors |
| 7000-7999 | Inorganic aerosols |
| 8000-8999 | Biological samples |
| 9000-9999 | Bulk samples; wipe samples |

c. Indexes and Appendixes

Within the NMAM website there is an online link to indexes that can be used to locate methods published in previous editions of the Manual:

1) Fourth Edition Methods

An index of fourth edition methods in order of method number. Note that the same method numbering system is used for third, fourth and fifth edition NIOSH methods. Also denoted is the current disposition of historical or discontinued methods.

2) First and Second Edition Method Numbers

An index of the first and second edition “P&CAM” and “S” methods, from which many of the subsequent methods were derived. This index shows the disposition of all of these earlier methods, whether they were later revised / updated or not.

3) Names and Synonyms

An alphabetical listing of chemical names and synonyms used in current (and many previous edition) methods, including CAS numbers.

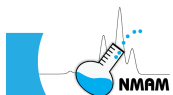

An online “Appendixes” link is also available for obtaining unit equivalents or for carrying out air concentration calculations for comparisons to Occupational Safety and Health Administration (OSHA) standards.

d. Method format

NIOSH methods consist of three major parts:

1) Front page

The first page of each method concisely summarizes sampling and measurement parameters and gives estimates of limit of detection, working range, overall and measurement precision, and interferences. References to other relevant methods are given. Also provided are Method Classification, NIOSH Registry of Toxic Effects of Chemical Substances (RTECS) number, and an estimate of method accuracy (see Figure 1).

2) Instructions

The second page of each method begins with lists of required reagents and equipment. Please note that these reflect the conditions under which the methods were evaluated and that there may still be some latitude for variation. The user of the methods is responsible for assuring the accuracy of the results (e.g., to determine that breakthrough and recovery are acceptable for each lot of samplers used). For example, typical tolerances for sorbent tubes are illustrated:

- Glass tubing used to contain solid sorbents: Inside diameter is usually not critical within the range of 4 to 6 mm; length should be sufficient to contain the specified mass of sorbent.
- Contents of sorbent tubes: Mass of sorbent within $\pm 10\%$ of specification; separators of either glass wool or cleaned polyurethane foam (unless otherwise indicated); sorbent mesh size of 20/40 unless sampling efficiency dictates otherwise. Filled sorbent tubes should be sealed to protect them from contamination.

The Special Precautions section gives guidance on safe practices to be observed during sampling, sampler preparation and measurement. Next are the step-by-step instructions for Sampling, Sample Preparation, Calibration and Quality Control, Measurement, and Calculations. Any lengthy instructions for sampler preparation and standardization of stock solutions appear in method appendixes. Nomenclature is consistent with the NMAM Glossary (chapter) of Abbreviations, Definitions and Symbols. (Note that additional general information relating to sampling and measurement is contained in other NMAM chapters.)

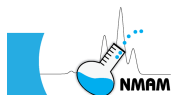

3) Supporting information

Laboratory and field data relating to the method are summarized in the Evaluation of Method section and on the summary page, along with pertinent references.

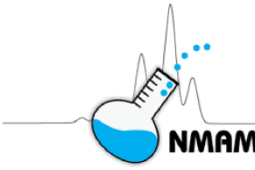
|  | | CHEMICAL NAME | METHOD #### |
|---|---|---|---|
| FORMULA | Molecular or Atomic Weight | Chemical Abstracts Service # | RTECS # |
| METHOD: number | | EVALUATION: (Full, Partial, Unrated, N/A) is assigned by NMAM editors. | Issue Date: |
| OSHA: | These exposure limit values, i.e., OSHA | PROPERTIES: Boiling/melting points, equilibrium vapor pressure, and density help determine the sample aerosol/vapor composition. | |
| NIOSH: | Permissible Exposure Limits (PELs) and/or | | |
| Other OELs: | NIOSH Recommended Exposure Limits (RELs), are those in effect at the time of publication of the method. | | |
| SYNONYMS: Common synonyms for the substance(s). | | | |
| SAMPLING | | MEASUREMENT | |
| SAMPLER: | Brief description of sampling equipment | TECHNIQUE: | The measurement technique used |
| FLOW RATE: | Acceptable sampling range, L/min | ANALYTE: | The chemical species actually measured. A summary of the measurement equipment, sample preparation and measurement steps appearing on the second page of the method is given here including detector specification. |
| VOL-MIN: | Minimum sample volume (L); corresponds to Limit of Quantitation (LOQ) | CALIBRATION: | Summary of type of standards used |
| -MAX: | Maximum sample volume (L) to avoid analyte breakthrough or overloading | RANGE: | Range of calibration standards to be used; from LOQ to upper limit of measurement (NOTE: More concentrated samples may be diluted in most cases to fall within the calibration range.) |
| SHIPMENT: | Indicates whether sample shipment is routine or requires special considerations, e.g., refrigeration | ESTIMATED LOD: | Limit of detection (Method Detection Limit) |
| SAMPLE STABILITY: | Indicates whether samples are stable or not, and over what time period and temperature range, etc. | PRECISION (\bar{S}_r): | Experimental precision of spiked samplers; precision of analytical method |
| BLANKS: | Each set should have at least 2 field blanks, up to 10% of samples, plus 6 or more media blanks in the case of coated sorbents, impinger solutions or other special samplers. | | |
| ACCURACY | | | |
| A summary of data from experiments in which known atmospheres of the substance were generated and analyzed according to the method including range studied, bias, overall precision (\bar{S}_r) and accuracy. Target accuracy is less than 25% difference from actual concentration over the range of the method. | | | |
| APPLICABILITY: The conditions under which the method is useful, including the working range in mg/m ³ (from the LOQ to the maximum sampler loading) for a stated air volume are given here. | | | |
| INTERFERENCES: Compounds or conditions which are known to interfere in either sampling or measurement are listed. | | | |
| OTHER METHODS: Methods from earlier editions of NMAM and current methods which are related to this one, as well as similar consensus standards, OSHA and literature methods. | | | |

NIOSH Manual of Analytical Methods (NMAM), Fifth Edition

Figure 1. Layout of front page of NIOSH methods

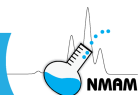

e. Method classification

Methods in previous (fourth) edition of NMAM are classified into evaluation categories: Full, Partial, Unrated and Not Applicable. Classification is based on the results of laboratory testing and evaluation criteria as described in a NIOSH guidelines document [NIOSH 1995] and in Chapter ME (Development and Evaluation of Methods). Most methods in the fifth edition are classified as 'fully validated.'

The performance data from these evaluations are summarized in the Evaluation of Method section in each method. This section may also contain other corroborating data, e.g., results from collaborative testing, Proficiency Analytical Testing (PAT) data, or field data from NIOSH studies. For partially evaluated methods, this section will state which evaluation points were not tested, thus providing the user with information on which to make a reasonable judgment on the quality of the data obtained.

Evaluation – Full: Fully evaluated methods are those that have been tested and found to have met all of the factors of the NIOSH evaluation protocol [NIOSH, 1995].

Evaluation – Partial: Partially evaluated methods are those that have been subjected to some of the evaluation experiments but have not received a full evaluation (e.g., short-term method development). These may also include methods that were fully tested but did not meet one or two of the evaluation criteria specified in the NIOSH protocol [NIOSH, 1995]; for example, some of the earlier-developed methods that do not meet the current $\pm 25\%$ accuracy criterion.

Evaluation – Unrated: Unrated methods have not been tested by NIOSH, but may have been developed by a recognized independent source such as OSHA.

Evaluation – N/A: The designation, Not Applicable (N/A), is applied to methods where no quantitative data are collected, such as:

- Procedures for sample collection only. The collected samples are analyzed subsequently by an appropriate analytical method.
- Qualitative methods that indicate results as a positive or negative (or inconclusive).

f. User experience with NIOSH methods

NIOSH strives to make the methods published in NMAM useful and fit for purpose in industrial hygiene analyses. Therefore, feedback on the experiences of people using the methods is important to us. Suggestions for improvement and questions relating to



NMAM are welcome and should be directed to the editors of the Manual. Their contact information is provided on the NMAM webpage.

Disclaimer

Mention of any company or product does not constitute endorsement by NIOSH. In addition, citations to websites external to NIOSH do not constitute NIOSH endorsement of the sponsoring organizations or their programs or products. Furthermore, NIOSH is not responsible for the content of these websites. All web addresses referenced in this document were accessible as of the publication date.

3 References

Angerer J, Greim H, eds. [2006]. Essential biomonitoring methods. Weinheim, Germany: Wiley-VCH.

Ashley K [2015]. NIOSH manual of analytical methods 5th edition and harmonization of occupational exposure monitoring. *Gefahrstoffe Reinh Luft* 75(1/2):7-16.

Behroozy A [2013]. On dermal exposure assessment. *Int J Occup Environ Med* 4:113-127.

Brisson M, Ashley K, eds. [2011]. Surface and dermal Sampling (ASTM STP No. 1533). West Conshohocken, PA: ASTM International.

DiNardi SR, ed. [2003]. The occupational environment – Its evaluation, control, and management, 2nd ed. Fairfax, VA: American Industrial Hygiene Association (AIHA).

Eduard W, Heederik D, Duchaine C, Green BJ [2012]. Bioaerosol exposure assessment in the workplace – The past, present and recent advances. *J Environ Monit* 14:334-339.

Hathaway GJ, Proctor NH, eds. [2004]. Chemical hazards of the workplace, 5th ed. New York: Wiley.

Jakubowski M [2012]. Biological monitoring versus air monitoring strategies in assessing environmental – occupational exposure. *J Environ Monit* 14:348-352.

Kulkarni P, Baron PA, Willeke K, eds. [2011]. Aerosol measurement – Principles, techniques, and applications, 3rd ed. New York: Wiley.



NIOSH [1995]. Guidelines for air sampling and analytical method development and evaluation. By Kennedy ER, Fischbach TJ, Song R, Eller PM, Shulman SA. Cincinnati, OH: National Institute for Occupational Safety and Health, DHHS (NIOSH) Publication No. 95-117.

Rose VE, Cohrssen B, eds. [2011]. Patty's industrial hygiene and toxicology, 6th ed. New York: Wiley.

Semple S, Cherrie, JW [2003]. Dermal exposure assessment. In: Nieuwenhuijsen MJ, ed. Exposure assessment in occupational and environmental epidemiology. Oxford, UK: Oxford University Press.

Vincent JH [2007]. Aerosol sampling – Science, standards, instrumentation, and applications. New York: Wiley.

Vincent JH [2012]. Occupational and environmental aerosol exposure assessment – A scientific journey from the past, through the present and into the future. *J Environ Monit* 14:340-347.



NIOSH Manual of Analytical Methods (NMAM), 5th Edition

Development and Evaluation of Methods

by Eugene R. Kennedy, Ph.D., Thomas J. Fischbach, Ruiguang Song, Ph.D., Peter M. Eller, Ph.D.,
Stanley A. Shulman, Ph.D., and R. DeLon Hull, Ph.D., NIOSH

| | | |
|---|--|-------|
| 1 | Method Development | ME-2 |
| 2 | Method Evaluation | ME-5 |
| 3 | Field Evaluation | ME-13 |
| 4 | Documentation | ME-14 |
| 5 | Appendix - Accuracy and its Evaluation | ME-15 |
| 6 | References | ME-17 |



**Centers for Disease Control
and Prevention**
National Institute for Occupational
Safety and Health

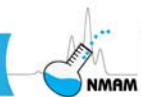

1 Method development

The development and evaluation of analytical methods that are useful, reliable and accurate for industrial hygiene monitoring problems require the application of some general guidelines and evaluation criteria. The guiding objective in this work requires that, over a specified concentration range, the method provide a result that differs no more than $\pm 25\%$ from the true value 95 times out of 100. The application of consistent evaluation criteria and guidelines is particularly important when methods are developed by different individuals and organizations (e.g., contractors or outside laboratories) and compiled into a single manual. Adherence to guidelines should minimize overlooking potential problems in the methodology during its development, as well as provide cohesiveness and uniformity to the method that is developed. This chapter provides an outline of a generalized set of evaluation criteria prepared by NIOSH researchers for the evaluation of sampling and analytical methodology [NIOSH 1995].

In the development of a sampling and analytical method, there is a logical progression of events that cover a search of the literature to gather pertinent information and the preliminary experimentation for selection of analysis technique and sampling medium. To initiate the development of a method, the identity of the analyte must be as fully defined as possible. Physical and chemical properties of the analyte should be defined so that procedures for proper handling and use of the analyte can be prepared. These also aid in establishment of analyte purity. Potential sources of this information include chemical reference books, health hazard evaluation reports, bulk sample analyses, material safety data sheets, chemical process information, etc.

Since innovation is a key element in the sampling and analytical method development process, detailed experiments for the initial development of the sampling approach and optimization of the analytical procedure are better left to the discretion of the researcher. During development, it should be recognized that appropriate, statistically designed experiments will optimize the amount of information obtained. Therefore, consultation with a statistician about appropriately designed experiments will be of value during this phase of the research.

a. Preliminary experimentation

Several key points, including calibration and selection of measurement technique and sampling media, should be studied during the initial method development experiments. The selection of sampling medium and procedure is a decision that usually is made early in the method development process. The physical state of the analyte (i.e., gas, aerosol, vapor, or combination thereof) plays an important factor in the selection of an appropriate sampler. Analytes which can exist in more than one physical state may require a



combination of sampling media in one sampler for efficient collection [NIOSH 1995]. Where possible, commonly available and easily used samplers should be investigated initially. As the preliminary testing of a sampling method progresses, further modification in the sampling medium or sampler design may be required and may affect the measurement procedure. Sampler design and media selection considerations should include U.S. Department of Transportation regulations and restrictions for shipment back to a laboratory for analysis.

Since industrial hygiene analytical methods are geared toward measuring personal exposure, the size, weight, and convenience of the sampler are important elements in sampler design. The personal sampler should allow freedom of movement and should be unobtrusive, unbreakable, and not prone to leakage. The pressure drop across the sampler should not be so great as to limit sample collection times to 10 h with personal sampling pumps. For situations where only a short term sample will be required (i.e., 15 min for ceiling determinations), this 10 h recommendations can be reduced to 1 h. The use of potentially toxic reagents should be avoided unless they can be used safely. Reagents used should not pose any exposure hazard to the worker wearing the sampler or to the industrial hygienist taking the samples.

b. Recovery of the analyte from the medium

During the course of method development experiments, the ability to recover the analyte from the sampling medium should be determined. A suggested experiment to accomplish this entails the fortification of sets of 6 samplers with amounts of analyte equivalent to sampling concentrations of 0.1, 0.5, 1.0, and 2.0 (or higher) times the exposure limit for a minimum of 4 h at the typical sampling rate used for that type of sampler. If the analyte has a ceiling or short-term exposure limit, the amount of analyte fortified should be adjusted for the shorter sampling time required for this type of exposure limit. If the sampler has a backup section, then a like number of separate backup sections should be fortified with amounts of analyte equivalent to 25% of the amount fortified on the front sections of the samplers, since this amount has been used to characterize the breakthrough limit of useful samples [Streicher et al. 1994]. Samples (and backup sections) should be prepared for analysis and analyzed according to previously determined procedures. Results of these analyses should be expressed in terms of estimated percent recovery according to the following formula:

$$\text{Percent Recovery}_{\text{(est.)}} = \left[\frac{\text{Amount of analyte found on sampler}}{\text{Amount of analyte fortified on sampler}} \right] \times 100 \%$$

After initial analyses of the samples, the samples should be resealed and analyzed on the following day, if possible. If the sample workup procedure results in a solution of the

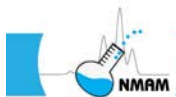

sample, these solutions should be recapped after the initial analysis, if possible, and reanalyzed on the following day using fresh standards.

The recovery of the analyte should be calculated for the primary and backup media in the sampler. Although complete recovery of the analyte from the sampler is most desirable, at a minimum, the estimated recovery of the analyte from the primary collection medium should be greater than or equal to 75% for concentrations equivalent to sampling 0.1, 0.5, 1.0, and 2.0 times the exposure limit. If recovery varies with analyte loading, results should be graphed as recovery versus loading during calibration of the method, so that appropriate correction can be made to sample results, as long as recovery is greater than 75% [Melcher et al. 1978]. If estimated recovery does not exceed 75%, the method is not suitable for monitoring at this limit.

Estimated recovery from any backup media should be noted so that appropriate corrections can be applied if breakthrough of the sampler has occurred during sampling. The recovery of the analyte from the medium in the backup section of a sampler may be different from that of the front section, since the backup section of a sorbent-based sampler usually contains only half of the sorbent of the primary section. If the same volume of desorption solvent is used for both the primary and backup sections of the sampler, the desorption equilibrium can be shifted, since the backup section is being desorbed by twice the volume (i.e., on a mL solvent/mg sorbent basis) [Saalwaechter et al. 1977].

Reanalysis of the samples on the day after initial analysis indicates if immediate analysis after sample preparation is required. Often when processing a large number of samples, it may be necessary to prepare the samples for analysis as a batch. In these instances, the last samples may not be analyzed for up to 24 h or more after preparation because of the time required for analysis. If samples prepared for analysis exhibit time-dependent stability after desorption, analyses must be conducted within acceptable time constraints. Analysis and reanalysis results should agree within 5% of each other.

c. Stability of the analyte on the medium

An extension to the experiment described above may be performed to investigate potential stability problems early in the experimentation. An additional set of fortified samples at each of the 4 concentrations should be prepared and analyzed after 7-days' storage at room temperature. Recovery should be similar to the above results within experimental error. Discrepancies larger than those expected by experimental error indicate sample stability problems that will need correcting by additional developmental effort (e.g., refrigerated storage). Comparison of results can be performed with statistical tests, such as an analysis



of variance (ANOVA) [Posner and Okenfuss 1981] test of the “Day” difference or a paired t-test [Box et al. 1978] of the means of the Day 1 and Day 7 storage results.

2 Method evaluation

After the initial development experiments for the method have been completed and a method has been proposed, the sampling and analysis approach should be evaluated to ensure that the data collected provides reliable, precise, and accurate results. Specifically, the goal of this evaluation is to determine whether, on the average, over a concentration range of 0.1 to 2 times the exposure limit, the method can provide a result that is within $\pm 25\%$ of the true concentration 95% of the time. For simplification, the true concentration is assumed to be represented by an independent method. An experimental approach for collecting the data necessary for this determination is described below.

As part of the evaluation of a method, the sampling of a generated atmosphere is needed to more adequately assess the performance of a method [NIOSH 1984; Nelson 1971; Nelson 1992]. This allows the determination of 1) the capacity of the sampler; 2) the efficiency of analyte collection by the sampler; 3) the repeatability of the method; 4) the bias in the method; 5) interferences in the collection of the sample. Concentration ranges to be used in the evaluation of the method should be based on several factors. These ranges, at a minimum, should cover 0.1 to 2.0 times the exposure limit. In some instances, higher multiples of the exposure limit can be added if needed (e.g., 10 times the exposure limit). In situations where multiple exposure limits (i.e., from different authorities) exist for an analyte, the lowest exposure limit should be used to set the lower limit of the evaluation range (0.1 times lowest exposure limit) and the highest limit used to calculate the upper limit of evaluation range (2 times the highest exposure limit). Intermediate evaluation concentrations should be within these exposure limits. The toxicity of an analyte (e.g., suspected carcinogenicity) may indicate that a concentration lower than that calculated by the exposure limit should be included in the measurement and evaluation ranges. Previous monitoring information from other methods may indicate that typical concentrations of the analyte may be below or above a concentration range based on the exposure limit. In this case, this lower or upper level may be included in the method evaluation.

a. Feasibility of analyte generation

In order to provide a realistic test of the method under study, air concentrations covering the range from 0.1 to 2 times the exposure limit of the analyte should be generated. The generated atmospheres should be homogeneous in concentration and representative of the environment encountered when sampling for the analyte in the workplace.



When attempting to generate a concentration of an analyte, the impact of environmental conditions, such as temperature, pressure, humidity, and interferences, on sampler performance and/or generation should be considered. The effect of elevated temperature on the collection medium of a sampler may decrease the capacity of the sampler or may decompose the analyte during generation and sampling. Reduced pressure may also reduce the capacity of a sampler. High relative humidity in many instances has been observed to reduce sampler capacity [Melcher et al. 1978]. In other instances it has increased sampler capacity [Cassinelli 1991]. A typical interference(s) should be generated along with the analyte to approximate a typical workplace sampling environment.

Generation of particulate material can be extremely complex [Willeke 1980; Hinds 1982], especially if particles of a required size range must be generated for the evaluation of a specified sampler inlet design. The aerodynamic performance of the generator is a factor in the generation of this type of atmosphere and should be evaluated carefully. Appropriate, independent methods should be available to verify particle size, if this is a critical element in the generation.

The concentration of the generated atmosphere should be verified either by well characterized gravimetric/volumetric means or by analysis of replicate samples (if possible) by an independent method at each concentration used. Further details on this verification are included in the literature [NIOSH 1995; Ashley 2015]. A statistician should be consulted for advice on the design and sample sizes to accomplish this validation. Ideally, the independent method should not be biased and should provide an accurate estimate of the concentration generated, assuming error is randomly distributed around the mean. Also the precision and bias of the independent method should be homogeneous over the concentrations investigated. (See NIOSH [1995] for the definitions of these attributes.) In instances where the concentration of the generator can be based only on calculations using flow rates in the generator and the amount of analyte injected, the generation system should be well characterized so that analyte losses are minimized.

In some instances, generation of an analyte may be difficult and even hazardous. As an alternative to direct generation in these cases, samplers may be fortified with an amount of analyte expected to be sampled over a specified period of time at a specific flow rate. When this is necessary, fortification of the sampler by vaporization of a known amount of analyte onto the sampling medium is a more appropriate method, since this approach more closely approximates a generated atmosphere. The alternative of direct application of a solution of analyte onto the collection medium is less desirable but may be necessary in some instances. After fortification, air, conditioned at both high and low humidity, should be drawn through samplers at the flow rate and time period used in the calculations for the



amount of analyte expected to be collected. In the method report, the fact that samples were not collected from a generated atmosphere should be discussed.

b. Capacity of the sampler and sampling rate

To determine the applicability of the sampling method, the capacity of the sampler should be determined as a function of flow rate and sampling time. This is particularly important if the analyte has both a short-term exposure limit (STEL) and a time-weighted average. Flow rates typical for the media selected should be used. These may range from 0.01 to 4 L/min, depending on sampler type. At extremely low flow rates (ca. 5 mL/min), the effect of diffusion of the analyte into the sampler must be considered. Flow rates should be kept at a high enough rate to prevent diffusion from having a positive bias in the sampler. Sampling should be performed at three different flow rates covering the range appropriate for the particular sampler type, unless the sampler is designed to operate at only one flow rate.

Sampling times should range from 22.5 min for STELs to 900 min (15 h) for time-weighted averages. Shorter sampling times (e.g., 7.5 to 22.5 min) may be used for ceiling (C) measurements. Flow rates should be based on accurately calibrated sampling pumps or critical orifices. The amount of analyte collected at the lowest flow rate and shortest sampling time should be greater than the limit of quantitation of the method. The generated concentration used for capacity determination should be at least 2 times the highest published exposure limit and verified by an independent method.

Sampling should be conducted at ambient, elevated ($>35\text{ }^{\circ}\text{C}$), and low ($<20\text{ }^{\circ}\text{C}$) temperatures to assess the effect of temperature on sampling. To assess the effect of humidity on capacity, sampling should be performed at both low and high humidity (20% and 80%), since both have been observed to affect capacity [Cassinelli 1991; Melcher et al. 1978]. Triplicate samplers at three different flow rates should be included to verify capacity at each of the six different humidity and temperature levels. For samplers which contain backup sampling media, only the front section of the sampler should be used. A means is required to quantitate analyte in the effluent from the sampler. This may involve the use of a backup sampler, continuous monitor or other appropriate means which can provide a measure of analyte concentration in the sampler effluent (ca. 1 to 5% of the influent concentration). If the mass of analyte found on a backup sampler totals 5% of the mass found on the front sampler or if the effluent concentration of the sampler contains 5% of the influent concentration, breakthrough has occurred and the capacity of the sampler has been exceeded.

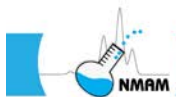

If the analyte is a particulate material and collected with a filter, the capacity of the filter is defined by the pressure drop across the sampler or by the loading of the filter. For 37-mm filter-based samplers, pressure drop should be less than 1000 mm of water for total loading less than 2 mg. Larger filters and especially filter capsules [Harper and Ashley 2013; O'Connor et al. 2014] will tolerate higher loadings (e.g, up to 5 mg).

If the collection process is based primarily on adsorption, breakthrough time should be proportional to the inverse of the flow rate [Jonas and Rehrmann 1973]. This relationship can be checked by plotting the 5% breakthrough time versus the inverse of the flow rate. If the resulting plot is a straight line, then this relationship should hold for all flow rates in the flow rate range studied. Some nonlinearity in the plot may be noted due to experimental variability and assumptions made to simplify the relationship of breakthrough time and flow rate. Results from these experimental trials should provide a prediction of the capacity of the sampler at various flow rates and sampling times. If the flow rates and sampling times used in the experiment do not provide for sufficient capacity, a lower flow rate range may have to be studied and the experiment repeated.

With samplers which use reagents for collection of the analyte, the amount of the reagent in the sampler will also be a limiting factor in the capacity of the sampler, based on the stoichiometry of the reaction. Other factors, such as residence time in the sampler and kinetics of reaction between analyte and reagent, may affect the capacity of this type of sampler.

The combined temperature and humidity conditions that reduce sampler capacity to the greatest extent should be used in all further experiments. The Maximum Recommended Sampling Time (MRST) for a specific flow rate is defined as the time at which sampler capacity was reached, multiplied by 0.667. This adds a measure of safety to this determination. The relationship of breakthrough time with flow rate can be used to adjust flow rates to optimize specific sampling times.

c. Sampling and analysis evaluation

To assess the performance of a method, certain additional experimental parameters should be evaluated through a series of defined experiments. The effect of environmental conditions (e.g., pressure, interferences) on sampling efficiency of the sampling medium can be evaluated by a factorial design [Box et al. 1978]. The temperature, relative humidity, flow rate, and sampling times, determined in the experiment described above to have most severely limited sampler capacity, should be used in these experimental runs [Ashley 2015]. At a minimum, the effect of concentration on method performance should be investigated. Three sets of 12 samples should be collected from an atmosphere containing



concentrations of 0.1, 1.0, and 2.0 times the exposure limit at the humidity determined above to have reduced sampler capacity for the MRST determined in the preceding experiment.

If the analyte has a short-term or ceiling exposure limit in addition to an 8-hour time-weighted average, an additional 12 samplers should be collected at the STEL or C limit for the recommended sampling period at the appropriate flow rate. Potential interferences in the work environment should be included in the generation experiments to assess their impact on method performance. Concentrations up to 2 times the exposure limit value for the interference should be included. Other environmental factors may be studied, but will require a more comprehensive experimental design.

The effects of environmental conditions on analyte recovery should be assessed. A factorial design can be used to evaluate these factors to determine which exert a significant effect on analyte recovery. Those factors which are found to influence analyte recovery should be investigated further to determine if their impact is predictable. If these effects are not predictable, the utility of the method will be limited, based on the conditions defined by this experiment. If only concentration is evaluated, the analyte recovery should be the same at all concentrations after correctable biases have been included, such as desorption efficiency.

d. Sample stability

To assess sample stability, samples should be collected from a generated atmosphere, stored under defined conditions (i.e., ambient or refrigerated, light or dark), and analyzed at specified time periods. A concentration of 0.5 times the lowest exposure limit should be sampled with 30 samplers for a minimum of $\frac{1}{2}$ the MRST. The humidity and temperature of the generator should be at the same level as defined in the sample capacity experiment to reduce sample capacity. The samplers should be divided randomly into one group of 12, one group of 6, and four groups of 3, with the group of 12 analyzed as soon after collection as possible (Day 0). The group of 6 samplers should be analyzed after 7 days. The four remaining sets of 3 samplers should be analyzed after 10, 14, 21, and 30 days. The conditions of storage are determined by the nature of the analyte. If there is an indication of analyte instability on the sampling medium, refrigeration of the samplers may be required. However, storage for the first 7 days should be at room temperature.

Samples should normally be stable for a minimum of 7 days under ambient conditions to simulate shipping to a laboratory for analysis. If the average analysis results of the samplers analyzed on day 7 differs from the set analyzed on day 0 by more than 10%, the method does not meet the sample stability criterion. Either additional precautions, such as



shipment on ice and refrigerator storage, may be required or the method may have to be modified to address this problem. (Note: In practice, reactive or unstable samples should be shipped by overnight mail and analyzed as quickly as possible.) If a plot of recovery versus time indicates that recovery decreased by more than 10% after the initial 7-day storage period, sample instability is a problem. If samples need to be stored for longer periods, more restrictive storage conditions are required. Remedial action, such as cold storage may solve this longer term storage problem. After remedial precautions have been instituted in the method, the sample stability of the method must be determined anew.

e. Precision, bias, and accuracy

Results from four sets of samplers used in the analyte recovery experiment, the sampling and analysis experiments (e.g., the environmental parameters experiments), and the sample stability experiment can be used for the estimation of precision, bias, and accuracy of the method. A more exacting treatment of this is described elsewhere [NIOSH 1995]. Sampler results from the multi-level factorial design at the 0.1, 1.0, and 2.0 times the exposure limit value; the sampler stability experiment (at 0.5 times the exposure limit); and the environmental factors experiment are used in the calculations of method precision. The calculations for the estimated method precision, \hat{S}_{RT} , have been described previously [NIOSH 1995; Anderson et al. 1981; Busch and Taylor 1981; NIOSH 1980]. Before obtaining a pooled estimate of method precision from the four sets of samplers listed above, the homogeneity of the precision over the range of concentrations studied should be checked using a test, such as Bartlett's test [NIOSH 1995; Anderson et al. 1981; Busch and Taylor 1981]. If the precision is not found to be constant over concentrations, the sample set collected at 0.1 times exposure limit should be removed and Bartlett's test recalculated. Homogeneity of the method precision at all concentration levels is an assumption required to obtain pooled estimate of method precision.

Bias is assumed to be homogeneous over the evaluation range. This assumption should be tested by estimating the bias at each concentration and testing these for homogeneity using the procedures described in the literature [NIOSH 1995]. Method bias should be less than 10%. A test for this is also described [NIOSH 1980].

The bias and precision estimates can be used with the graph presented in Figure 1 or in Table I to estimate accuracy [NIOSH 1995]. The bias and precision estimates are plotted on the x- and y-axes of the graph. The intersection of these points on the parabolic grid in the graph can be used to estimate the accuracy of the method. This procedure gives an estimate of method accuracy but does not yield the statistic required to test compliance of the method with the $\pm 25\%$ accuracy criterion. Techniques for the latter determination are discussed in the Appendix and elsewhere [NIOSH 1995].

If the results for 4 concentrations fail the 25% accuracy criterion, then the set of samples collected at the lowest concentration level should be excluded from the data set. The pooled \hat{S}_{RT} and the bias should be recalculated on this reduced data set before performing the accuracy analysis described in the previous paragraph.

For the 12 samplers collected at the ceiling limit, the accuracy analysis described above should be repeated using only the data collected at the ceiling limit.

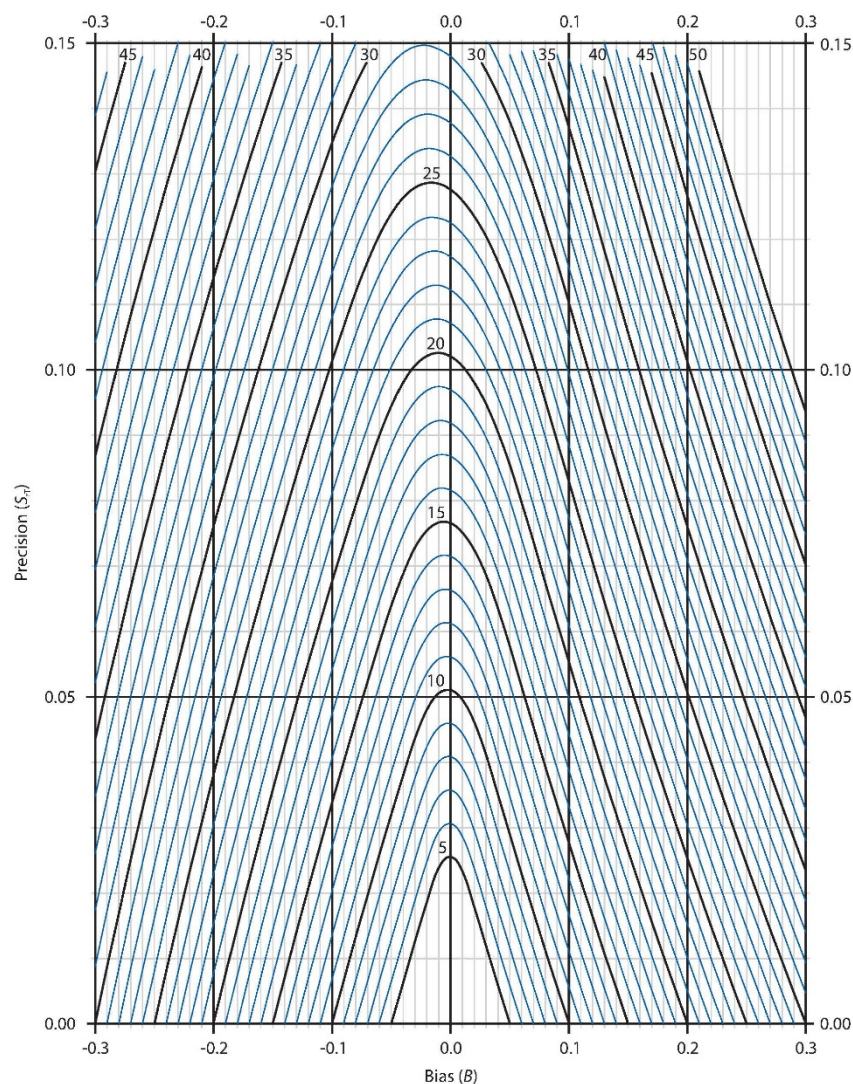

Figure 1. Nomogram relating accuracy to precision and bias. Accuracy (A), in percentage units, is a function of the bias (B) and the precision (S_{RT}). Each curve is the locus of all points (B, S_{RT}) that yield the value of A indicated on the curve.



Table I. Values of the bias (B) and the precision (S_{rt}) required to obtain designated values of accuracy (A) in percentage units[#]

| A (%) | B (%) | S_{rt} (%) |
|-----------------|------------------------|--------------|
| 5 | -3.5 | 0.945* |
| 5 | -2.5 | 1.559* |
| 5 | 0.0 | 2.551* |
| 5 | 2.5 | 1.483* |
| 5 | 3.5 | 0.881* |
| 10 | -7.5 | 1.643* |
| 10 | -5.0 | 3.200 |
| 10 | 0.0 | 5.102 |
| 10 | 5.0 | 2.895* |
| 10 | 7.5 | 1.414* |
| 15 | -10.0 | 3.378* |
| 15 | -5.0 | 6.381 |
| 15 | 0.0 | 7.653 |
| 15 | 5.0 | 5.774 |
| 15 | 10.0 | 2.764* |
| 20 | -10.0 | 6.755 |
| 20 | -5.0 | 9.448 |
| 20 | 0.0 | 10.20 |
| 20 | 5.0 | 8.548 |
| 20 | 10.0 | 5.527 |
| 25 | -10.0 | 10.13 |
| 25 | -5.0 | 12.39 |
| 25 | 0.0 | 12.75 |
| 25 | 5.0 | 11.21 |
| 25 | 10.0 | 8.287 |
| 30 [§] | -15.0 ^{&} | 10.73 |
| 30 [§] | -7.5 | 14.55 |
| 30 [§] | 0.0 | 15.31 |
| 30 [§] | 7.5 | 12.52 |
| 30 [§] | 15.0 ^{&} | 7.930 |
| 35 [§] | -15.0 ^{&} | 14.31 |
| 35 [§] | -7.5 | 17.59 |
| 35 [§] | 0.0 | 17.86 |
| 35 [§] | 7.5 | 15.14 |
| 35 [§] | 15.0 ^{&} | 10.57 |

Note: the values shown in this table are population or theoretical values.
 * Below the minimum attainable precision with a 5% pump correction.
 § Does not fulfill the Accuracy Criterion ($\pm 25\%$ of the true value).
 & Does not fulfill the bias criterion ($\pm 10\%$).

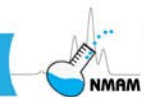

3 Field evaluation

While field evaluation is not required in method evaluation, it does provide a further test of the method, since conditions which exist in the field are difficult to reproduce in the laboratory. Also unknown variables may affect sampling results when field samples are taken. This type of evaluation is recommended to further study the performance of the method in terms of field precision, bias, interferences and the general utility of the method. Both the collection of area samples and personal samples should be included in the field evaluation of the method.

Area samples should provide an estimate of field precision and bias. Personal samples may confirm these values and also provide a means to assess the utility of the method. A statistical study design should be prepared, based on the variability of the method and the statistical precision required for estimates of the differences in analyte concentrations yielded by the independent method and the method under evaluation [CEN 2015].

If this type of statistically designed study is not feasible, a minimum of 20 pairs of samples of the method under study and an independent method should be used for personal sampling. Placement of the samplers on the workers should be random to prevent the biasing of results due to the "handedness" of the worker. Workers sampled should be in areas where both low and high concentrations of the analyte may be present.

As a minimum, sets of 6 area samplers paired with independent methods should be placed in areas of low, intermediate, and high analyte concentration. If the atmosphere sampled is not homogeneous, precautions may have to be taken to ensure that all samplers are exposed to the same concentrations. This can be done by using field exposure chambers, such as those described in the literature [Cassinelli et al. 1985; Kennedy et al. 1985].

Field precision and bias of the area sampler results of the method under study should compare with laboratory evaluation results, provided that precautions have been taken to ensure that all samplers have been exposed to the same homogeneous atmosphere. Differences in precision and bias should be investigated. Sources of variation should be studied and corrections implemented where necessary. Evaluation of personal sampler results should be done cautiously, because observable differences may be due to work practices or other situations which are beyond the control of the method.

A field evaluation of a method also allows the developer of the method to determine its ruggedness. Although this may be a subjective judgement, first-hand experience with the method in the field may suggest changes in the sampler or method that may make the method more easily used in the field and less subject to variability.

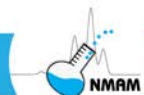

4 Documentation

Development and evaluation research on a sampling and analytical method should be documented in a final report. The report should describe what was determined about the method. If the results of the statistical analysis of the data indicate there is not 95% confidence that the accuracy of the method is less than or equal to $\pm 25\%$, the report should state this fact. In some instances, the method may actually have an accuracy of less than 25%, but a larger sample size must be used to prove this statistically (See Appendix 1 of NIOSH 1995).

The final report can be either a technical report or a failure report. The technical report (acceptable method developed) documents the successful development of the method. This report may be prepared in a format appropriate for submission to a peer-reviewed journal for publication. The failure report (no acceptable method developed) documents the research performed on an attempted method development for an analyte or analytes. The report should describe the failure of the method, as well as other areas of the method research that were successful. Recommendations to solve the failure of the method may be included.

If an acceptable method is developed, a sampling and analytical method should be prepared in appropriate format. The format of the resulting method should provide clear instructions for the use of the method. Sampling, sample workup, and analysis procedures should be clearly described. The necessary equipment and supplies for the method should be listed clearly in the method. A summary of the evaluation of the method should be included, as well as a discussion of method applicability and lists of interferences and related references. As a check on the clarity and performance, new methods should be reviewed and submitted to a user check (i.e., the method is used to analyze spiked or generated samples of known concentration by someone other than the researcher who developed it) and to a collaborative test, if feasible.

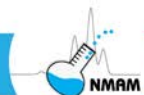

5 Appendix - Accuracy and its evaluation

In the development of a sampling and analytical method, one of the goals is to minimize the measurement error to the lowest feasible and practical levels. It is assumed that all feasible corrections to reduce error have been made in the laboratory experimentation process. Method evaluation requires adequate characterization of the magnitude and distribution of the uncorrectable error that cannot be prevented. One might consider a hypothetical experiment in which a method is used repeatedly to measure the same concentration, T , under the same conditions. These measurements would tend to exhibit a pattern or statistical distribution, here assumed to be normal, with a mean, μ , and standard deviation, \hat{S} . The distribution can be characterized in terms of two components: its location relative to T , which is the systematic error termed bias (B), is given by $(\mu - T)/T$; and its spread, which is the random error termed imprecision (\hat{S}_{rT}), is given by \hat{S}/μ . The bias and imprecision are used to determine the inaccuracy of the method but they are also important characteristics of the error in and of themselves, as will be discussed below.

Accuracy refers to the closeness of the measurements to T but it is defined in terms of the discrepancy of the measurements from T . Inaccuracy (I) is defined as the maximum error, regardless of sign, expressed as a percentage of T that occurs with a probability of 0.95. Thus, an inaccuracy (or accuracy) of 20% means that on the average 95 of every 100 measurements will differ from T by no more than $0.2T$. The accuracy criterion for single measurements mentioned at the beginning of this chapter, often termed the “NIOSH Accuracy Criterion,” requires inaccuracy to be less than or equal to 25%.

Accuracy, bias, and imprecision have the following relationship:

$$0.95 = \Phi((1-B)/((1+B)S_{rT})) - \Phi((-1-B)/((1+B)S_{rT}))$$

where Φ denotes the probability that a standard normal random variable is less than or equal to Φ . A practically exact numerical solution to Equation (1) can be readily programmed using statistical software packages [Press et al. 1986]. A DOS program, ABCV.EXE, is also available which solves for I (denoted by A in the program), \hat{S}_{rT} (denoted by CV in the program), or B when the values for the other two quantities are input. An estimate of I can be obtained in either case by entering estimates of B and \hat{S}_{rT} . An approximate solution, which is accurate to about 1.1 percent, is given as follows [NIOSH 1995]:

$$I = 1.57 (B+1)S_{rT} + \sqrt{((0.39 (B + 1) \cdot S_{rT})^2 + B^2)} \quad \text{for theoretical or true } I$$

$$\hat{I} = 1.57 (\hat{B} + 1)\hat{S}_{rT} + \sqrt{((0.39 (\hat{B} + 1) \cdot \hat{S}_{rT})^2 + \hat{B}^2)} \quad \text{for estimates of } I$$



Also, the nomogram in Figure 1 can be used to solve for I or an estimate of I by entering B and S_{RT} or their estimates. Procedures for obtaining “best” single point and 95% confidence interval estimates of B , and S_{RT} and a 90% confidence interval estimate for I are given in NIOSH [1995].

The 90% confidence interval for I can be used to infer whether the method passes or fails the 25% accuracy criterion (AC) for single measurements with 95% confidence as follows:

- 1) The method passes with 95% confidence if the interval is completely less than 25%.
- 2) The method fails with 95% confidence if the interval is completely greater than 25%.
- 3) The evidence is inconclusive if the interval includes 25% (there is not 95% confidence that the AC is true or that it is false).

When researchers interpret the results from analyses of the type described above, it is important to consider that most methods have many uses in addition to individual measurement interpretation. Because accuracy is very important whenever any quantity is to be estimated, the ideal (“other things being equal”) is to use the most accurate estimator regardless of its bias or imprecision. However, it is crucial to distinguish between the accuracy of the source or “raw” measurements and that of the final estimator, which might involve many intermediate analyses or operations. Unfortunately, the most accurate input or raw measurements do not always produce the most accurate final result unless the latter is a single measurement. The bias and imprecision of the source measurements can be differentially affected by intermediate operations in producing the final estimate. For example, if the final estimate is a function of a single average of many source measurements, its bias is not affected by the averaging while imprecision is reduced as a function of the square root of the number of measurements. Thus, a lower biased method might be preferable to another even if the inaccuracy of the latter is less. On the other hand, in comparative studies, the desired estimate is either a difference or ratio of means of measurements in which there can be partial or complete cancellation of the bias in the source measurements. Thus, the bias of the method used for the source measurements may be of little importance. If there are several methods applicable for a given user’s project (regardless of whether all fulfill the accuracy criterion for single measurements), the analyst would be well-advised to consult with the user (preferably in advance of measurement) to determine which of those methods would produce the optimal accuracy for the final results or estimates needed by that particular user. Accuracy, bias, and imprecision jointly form a complete or sufficient set for the efficient description of the measurement error characteristic of any method.



Disclaimer

Mention of any company or product does not constitute endorsement by NIOSH. In addition, citations to websites external to NIOSH do not constitute NIOSH endorsement of the sponsoring organizations or their programs or products. Furthermore, NIOSH is not responsible for the content of these websites. All web addresses referenced in this document were accessible as of the publication date.

6 References

- Anderson C, Gunderson E, Coulson D [1981]. Sampling and analytical methodology for workplace chemical hazards. In: Choudhary G, Ed. Chemical Hazards in the Workplace. Washington: American Chemical Society, pp. 3-19.
- Ashley K [2015]: NIOSH Manual of Analytical Methods 5th edition and harmonization of occupational exposure monitoring. *Gefahrstoffe Reinh Luft* 75:7-16 (and references therein).
- Box GEP, Hunter WG, Hunter JS [1978]. Statistics for experimenters. New York: John Wiley & Sons.
- Busch K, Taylor D [1981]. Statistical protocol for the NIOSH validation tests. In: Choudhary G, ed. Chemical Hazards in the Workplace. Washington: American Chemical Society, pp. 503-517.
- Cassinelli ME [1991]. Development of a solid sorbent monitoring method for chlorine and bromine in air with determination by ion chromatography. *Appl Occup Environ Hyg* 6:215-226.
- Cassinelli ME, Hull RD, Cuendet PA [1985]. Performance of sulfur dioxide passive monitors. *Am Ind Hyg Assoc J* 45:599-608.
- Comité Européen de Normalisation (CEN) [2015]. EN 482:2012+A1:2015 Workplace exposures - General requirements for the performance of procedures for the measurement of chemical agents. Brussels, Belgium: Comité Européen de Normalization.
- Harper M, Ashley K [2013]. Acid-soluble internal capsules for closed-face cassette elemental sampling and analysis of workplace air. *J Occup Environ Hyg* 10:297-306.
- Hinds WC [1982]. Aerosol technology. New York: John Wiley & Sons.



Jonas LA, Rehrmann JA [1973]. Predictive equations in gas absorption kinetics. *Carbon* 11:59-64.

Kennedy ER, Smith DL, Geraci CL [1985]. Field evaluations of sampling and analytical methods for formaldehyde. In: Turoski V, ed. *Formaldehyde – Analytical Chemistry and Toxicology*, Washington, DC: American Chemical Society, pp. 151-159.

Melcher R, Langner R, Kagel R [1978]. Criteria for the evaluation of methods for the collection of organic pollutants in air using solid sorbents. *Am Ind Hyg Assoc J* 39:349-361.

NIOSH [1980]. Development and validation of methods for sampling and analysis of workplace toxic substances. By Gunderson E, Anderson C, Smith R, Doemeny L, Busch K. Cincinnati, OH: U.S. Department of Health and Human Services, Centers for Disease Control and Prevention, National Institute for Occupational Safety and Health; DHHS (NIOSH) Publication No. 80-133.

NIOSH [1984]. Gas and vapor generating systems for laboratories. By Woodfin W. Cincinnati, OH: U.S. Department of Health and Human Services, Centers for Disease Control and Prevention, National Institute for Occupational Safety and Health; DHHS (NIOSH) Publication No. 84-113.

NIOSH [1995]. Guidelines for air sampling and analytical method development and evaluation. By Kennedy ER, Fischbach TJ, Song R, Eller PM, Shulman SA Cincinnati, OH: U.S. Department of Health and Human Services, Centers for Disease Control and Prevention, National Institute for Occupational Safety and Health; DHHS (NIOSH) Publication No. 95-117.

O'Connor S, O'Connor PF, Feng HA, Ashley K [2014]. Gravimetric analysis of particulate matter using air samplers housing internal filtration capsules. *Gefahrstoffe Reinh Luft* 74:403-410.

Posner J, Okenfuss J [1981]. Desorption of organic analytes from activated carbon. *Am Ind Hyg Assoc J* 42:643-646.

Press WH, Flannery BP, Teukolsky SA, Vettering WT [1986]. *Numerical recipes – the art of scientific computing*. Cambridge, UK: Cambridge University Press.

Saalwaechter A, McCammon C, Roper C, Carlberg K [1977]. Performance of the NIOSH charcoal tube technique for the determination of air concentrations of organic vapors. *Am Ind Hyg Assoc J* 38:476-486.



Streicher R, Kennedy E, Lorderau C [1994]. Strategies for simultaneous collection of vapours and aerosols with emphasis on isocyanate sampling. *Analyst* 119:89-97.

Willeke K, ed. [1980]. *Generation of Aerosols and Facilities for Exposure Experiments*. Ann Arbor, MI: Ann Arbor Science Publishers.



NIOSH Manual of Analytical Methods (NMAM), 5th Edition

Measurement Uncertainty and NIOSH Method Accuracy Range

by David L. Bartley, PhD, Stanley A. Shulman, PhD, and Paul C. Schlecht, MS, NIOSH

| | | |
|---|---|-------|
| 1 | Introduction | UA-2 |
| 2 | ISO GUM | UA-4 |
| 3 | The symmetric accuracy range A as used by NIOSH | UA-6 |
| 4 | Uncertainty and analytical lab procedures | UA-9 |
| 5 | Discussion | UA-13 |
| 6 | Technical notes | UA-14 |
| 7 | References | UA-20 |
| 8 | Terminology | UA-22 |



**Centers for Disease Control
and Prevention**
National Institute for Occupational
Safety and Health

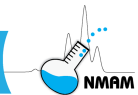

1 Introduction

Recently, the ISO Guide to the Expression of Uncertainty in Measurement (GUM) has come close to being universally adopted as the standardized way to characterize and document measurement uncertainty [ISO 2002, 2005, 2009, 2010; Ellison and Williams 2012]. Since the mid-1970s, accuracy criteria have been an integral part of the evaluations of the sampling and analytical methods used by the National Institute for Occupational Safety and Health (NIOSH), the Occupational Safety and Health Administration (OSHA), the Mine Safety and Health Administration (MSHA), and others. NIOSH has previously published extensive discussions addressing the issue of accuracy as a factor in the development, evaluation, and characterization of analytical methodology. Both traditional method accuracy and new measurement uncertainty concepts are intended to communicate measurement limitations to laboratory clients. Naturally, laboratories are interested in how NIOSH accuracy requirements [Busch 1977; NIOSH 1995] relate to measurement uncertainty.

This chapter provides guidance for achieving consistency in determining measurement uncertainty by those laboratories using NIOSH methods. Minor modifications to NIOSH accuracy measures, and an expansion of ISO GUM to cover situations unique to workplace atmospheric measurement can improve consistency and utility. See Bartley [2004] for additional information.

ISO GUM proposes pooling estimated variance components from diverse error sources. The square root of the pooled variance estimate is termed the *combined uncertainty* u_c . Multiplication of u_c by a *coverage factor* k (generally in the range of 2 to 3) results in an *expanded uncertainty* U . The purpose of the expanded uncertainty is for each measurement to provide an interval bracketing the *measurand* (the true value of what is to be measured) to account for errors in both the measurement and the determination of the uncertainty components themselves.

ISO GUM is somewhat unclear about the *coverage factor* k . Furthermore, the coverage factor can be interpreted in several ways. Most straightforward is the limited case where the uncertainty components can be re-evaluated each time the method is used (resulting in k proportional to a Student-t quantile). In this case, the covering intervals bracket the *measurand* for (for example) 95% of the measurements.

Alternatively, the coverage factors based on the Student-t quantile specify intervals containing measurand values at levels of evaluation confidence in the *mean* (i.e., averaging over many method evaluations). In other words, for roughly 50% of method evaluations, intervals used at each measurement contain the measurand value greater than (for example) 95% of the time. The concept is consistent with the statistical theory of tolerance or prediction intervals.

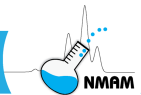

This approach is important to industrial hygiene since workplace air concentrations vary spatially and over time to such a degree that a method cannot be evaluated by simply taking replicate measurements [Vaughan et al. 1990]. However, industrial hygiene measurement methods have traditionally required confidence levels greater than 50% in the method evaluation. Generally, 95% confidence in a method validation is required. The different types of confidence levels are reflected simply in the numerical value and interpretation of the coverage factor.

Of equal importance in the industrial hygiene field are details needed to handle systematic error (*bias*) relative to reference concentration measurements found during method evaluation. For example, the sampling rate of a given diffusive sampler for gases or vapors is generally measured once by the diffusive sampler manufacturer prior to use by multiple clients. As the samplers are not re-calibrated for each use, residual *bias* exists in the measurements due to uncertainty in sampling rates used [ASTM 2013a]. (NIOSH methods typically do not cite performance for passive samplers because agreement among diffusive monitor manufacturers on test protocols has not yet been achieved, and a system of third party evaluation of diffusive monitor manufacturers sampling rates is not available.) Similarly, the calculation of desorption efficiencies may be performed only once or infrequently and can, therefore, introduce residual *bias* in measurements that use sorbent-captured samples, e.g., charcoal tubes.

In aerosol sampling, detailed knowledge of the particle size-dependent *bias* of a sampler relative to a sampling convention, such as adopted by ISO/CEN/ACGIH/ASTM [ISO 1995; CEN 1993; ACGIH 2015; ASTM 2013b] for defining respirable dust, is often necessary to judge the usefulness of a given sampler. Each type of aerosol sampler is characterized by specific particle collection characteristics, and some analytical methods (e.g. silica) may also exhibit particle size effects. Typically the issue of aerosol sampler *bias* is avoided or minimized in the industrial hygiene field by narrowing use to a specific aerosol sampler. For example, common industrial hygiene practice establishes a single sampler type, such as the 1.7 L/min 10-mm nylon Dorr-Oliver cyclone, for respirable dust sampling in a particular application.

Sensitivity to other environmental factors, referred to in ISO GUM as *influence variables*, must be acknowledged. Suppose a sampler is sensitive to temperature changes that are impractical to measure in the field; i.e., sampler estimates are not temperature corrected. Then, suppose during method evaluation in the laboratory, measurement of this sensitivity is combined with knowledge of the expected temperature variation for a given field application. Putting together both would determine the uncertainty associated with the effect. Examples of the important effects of influence variables - such as wind velocity, temperature, pressure, and fluctuating workplace concentrations - on diffusive monitor uptake rates are common.



2 ISO GUM

ISO GUM presents several concepts. One of these calls for the identification of sources (labeled $j = 1, 2, \dots$) of uncertainty u_j (standard deviation estimate components) in a measurement method and for their classification into Type A or Type B uncertainties. Type A uncertainty is one that has been characterized by a statistically sound approach. In this case, u_j^2 is given by s_j^2 , an unbiased estimate (with ν_j degrees of freedom) of variance σ_j^2 . On the contrary, Type B uncertainty generally requires professional judgment. See Table 1 for examples of possible uncertainty components.

A common example of Type B uncertainty is the conservative assignment of a 5% relative standard deviation component (without error, i.e., with infinite degrees of freedom) as the random sampling pump uncertainty. As described in ISO GUM, such an assignment would be a result of sampling pump random errors that had a uniform distribution and fell within $\pm\sqrt{3} \times 5\%$ of zero with a probability “for all practical purposes equal to one”. Therefore, if it is judged that sampling pump variations are *within* these bounds, then the assignment of 5% as the relative standard deviation component is conservative. Other similar ways of handling Type B uncertainties are found in ISO GUM.

Table 1. Examples of potential uncertainty component sources.

Sampling

- personal sampling pump flow rate: setting the pump and subsequent drift sampling rate of diffusive sampler
- sampler dimension (aerosol and diffusive sampling)

Sample handling

- sample preparation (e.g., handling silica quasi-suspensions) sample loss during transport or storage

Analytical

- aerosol weighing
- recovery (e.g, GC-based methods)
- Poisson counting (e.g., in XRD methods)
- Sensor variation
- operator effects giving inter-lab differences (if data from several labs are to be used)



Evaluation

- calibration material uncertainty
- evaluation chamber concentration uncertainty
- other bias-correction uncertainty

Environmental influence parameters

- temperature (inadequacy of correction, if correction is made as with diffusive samplers)
- atmospheric pressure
- humidity
- aerosol size distribution (if not measured by a given aerosol sampling method)
- ambient wind velocity
- sampled concentration magnitude itself (e.g., sorbent loading)

Within the field of industrial hygiene, the quantities u_j are often standard deviation component estimates obtained from a *single* measurement-method evaluation, rather than from replicates. When the estimates are independent, a *combined uncertainty* u_c may be computed (through the propagation of uncertainty approximation) as:

$$u_c = \sqrt{u_1^2 + u_2^2 + \dots} \quad (1)$$

Through a *coverage factor* k , generally approximated conservatively (e.g., see *Technical Note 2* at end of chapter), as equal to 3 for a single method evaluation, an *expanded uncertainty* U may be computed as:

$$U = k \times u_c \quad (2)$$

The purpose of the expanded uncertainty U is to provide intervals, which generally contain measurand values (often referred to as the *true* values). In particular, given a concentration estimate \hat{c} (hats, as here, indicate estimates), the measurand value C is bracketed at better than 95% confidence by intervals of the type:

$$\hat{c} - U < C < \hat{c} + U \quad (3)$$

at 95% confidence in the method evaluation. The coverage factor k is intended to account for both (1) the fluctuation of the measurement about the measurand value and (2) the uncertainty in the assessment of this fluctuation.

Note: Requiring only mean confidence in the evaluation leads to k given in terms of a *Student-t* quantile. Here, however, in fixing the method evaluation confidence (e.g., at 95%), the *chi-*

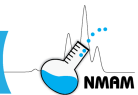

square distribution takes the place of the Student-t distribution. Double confidence levels (in the measurement and evaluation) directly relate to a well-developed [Bartley 2001; Bartley and Irwin 2002; Hald 1952; Wald 1942, 1943; Wald and Wolfowitz 1946; Wilks 1941, 1942; Aitchison and Dunsmore 1975] statistical theory of *tolerance* or *prediction intervals*.

Another point of ISO GUM is semantic. *Uncertainty*, as in common usage, covers only what is *unknown* about a measurement. The *known* but uncorrected systematic deviation or *bias* relative to reference concentrations does not enter into measurement uncertainty.

A related concept, *accuracy*, is defined qualitatively within ISO GUM as the “closeness of agreement between the result of a measurement and a true value of the measurand”. Accuracy can have both random and systematic components. It is not surprising then that if a *bias* correction is made and if accuracy is quantified reasonably, the expanded uncertainty and an accuracy confidence limit can be equivalent.

As mentioned above, another aspect of ISO GUM deals with *influence factors*. If measurement results are expected to be sensitive to an environmental factor (e.g., ambient temperature), then the effect of such a factor on the measurement method must be measured in the laboratory. Given estimates of the environmental variations expected during method application, influence components of the combined uncertainty can be estimated for inclusion in the uncertainty budget of Eq. 1. Table 1 lists several *influence factors*, which may or may not be significant.

3 The symmetric accuracy range A as used by NIOSH

a. Definition and its approximation

The *symmetric accuracy range A* is defined as the fractional range, symmetric about the true concentration C , within which 95% of sampler measurements \hat{c} are to be found.

Another way of saying this is:

$$C \times (1 - A) < \hat{c} < C \times (1 + A) \quad \text{for 95\% of measurements } \hat{c} \quad (4)$$

It is clear from this simple definition that the accuracy range function A must increase with both random effects and *bias* magnitude and therefore, is one means of quantifying accuracy as defined above according to ISO GUM.

More specifically, suppose that estimates \hat{c} are normally distributed about population mean c with standard deviation σ . Then we may characterize random measurement effects

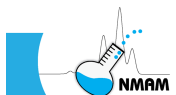

in terms of the (true) relative standard deviation $TRSD$ and $bias$ of the mean concentration estimate c relative to the true concentration C as:

$$bias = \frac{c - C}{C}$$
$$TRSD = \frac{\sigma}{C}.$$
(5)

The descriptive definition of Eq. 4 implies that the symmetric accuracy range A increases with both $TRSD$ and $bias$ magnitude $|bias|$. This feature can be seen directly in the following close approximation to the accuracy range function A , which follows [See Bartley 2001; Bartley and Irwin 2002 for derivation] from the definition in Eq. 4:

$$A = 1.960 \times \sqrt{bias^2 + TRSD^2}, \text{ if } |bias| < \frac{TRSD}{1.645};$$
$$A = |bias| + 1.645 \times TRSD, \text{ otherwise.}$$
(6)

This expression is simple enough for calculation by most hand-held calculators, and it is also a useful starting point for estimating the 95% confidence limit $A_{95\%}$ on the accuracy range as measured during a method evaluation, accounting for evaluation errors.

b. Uses of the symmetric accuracy range

1) Method validation

One application of the symmetric accuracy range is for evaluating measurement methods. As mentioned in NMAM guidance chapters, a method evaluation consists of a number of measurements taken from replicate samplers at each of several controlled and known concentrations covering the range of expected method application. This type of experiment gives information about the samplers' random errors and also the $bias$ relative to reference concentrations. A confidence limit on the accuracy range can then be computed. One objective in a method suitable for NIOSH application is that the 95% confidence limit $A_{95\%}$ not exceed 25%. A includes both the uncertainty (as the term is used by ISO GUM) and the systematic deviation or $bias$, so that correction of the $bias$ by the sampler vendor or developer is encouraged by the very statement of this objective. See Eqs. 9-11 below for computing $A_{95\%}$ when $bias$ is negligible.

2) Measurement uncertainty

Suppose then that $bias$ correction has been made. For example, suppose that following evaluation, the sampler is used for future measurement with $bias$ corrected on the basis of its measurement during the evaluation itself. Then computation of the confidence

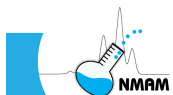

limit $A_{95\%}$ is possible accounting for the residual *bias* which is uncorrectable due to evaluation limitations, but nevertheless will be present in all future measurements. The quantity $\hat{c} \times A_{95\%}$ forms the counterpart to the expanded uncertainty U of ISO GUM for specifying evaluation confidence at 95%.

The relationship between $\hat{c} \times A_{95\%}$ (with corrected *bias*) and *expanded uncertainty* U can be seen most clearly in the case that $A_{95\%}$ is significantly smaller than 100%. In this case, Eq. 4 can be rewritten as the approximation:

$$\hat{c} - \hat{c} \times A_{95\%} < C < \hat{c} + \hat{c} \times A_{95\%}, \quad (7)$$

which means that at 95% confidence in the method evaluation, the inequality bracketing the measurand value C holds at probability $> 95\%$. A study using 10,000-point simulations indicates that $A_{95\%}$ can be as large as 25%, with method evaluation confidence close to 95% using the approximation of Eq. 7. As can be seen directly, Eq. 7 is the analogue to Eq. 3 when $\hat{c} \times A_{95\%}$ is adopted as the *expanded uncertainty* U :

$$U = \hat{c} \times A_{95\%}. \quad (8)$$

In the case that *bias* is known to equal zero (*Technical Note 1* at the end of this chapter), $A_{95\%}$ (at 15 degrees of freedom in the evaluation experiment) is simply:

$$A_{95\%} = 2.8 \times TRSD. \quad (9)$$

Eq. 8 then gives:

$$\begin{aligned} U &= 2.8 \times TRSD \times \hat{c} \\ U &= 2.8 \times u_c. \end{aligned} \quad (10)$$

Therefore, the coverage factor k is

$$k = 2.8, \quad (11)$$

consistent with the use of $k = 3$ as a conservative but not excessive value.

The user of a method then may report the expanded uncertainty U in a concentration Estimate \hat{c} using Eq. 8, knowing the accuracy range confidence limit $A_{95\%}$ as reported in the method. Of course, this approach relies on the sense of double confidence—in the evaluation and also in the subsequent application.

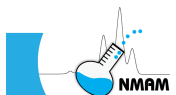

Note: The European Assessment of Workplace Exposures Technical Committee, CEN TC 137, has adopted a similar viewpoint regarding method performance [CEN 2015]. In this case, an *overall uncertainty*, defined as $|bias| + 2 \times RSD$, is used to quantify accuracy. When compared to Eq. 6, the overall uncertainty can be regarded as an approximation to the symmetric accuracy range.

4 Uncertainty and analytical lab procedures

Interest in measurement uncertainty and ISO GUM is currently finding its way into the criteria for the accreditation of analytical labs [ISO 2005]. The result will no doubt be high confidence in understanding one component of the combined or expanded uncertainty—namely the analytical component. Several general approaches to controlling and characterizing analytical uncertainty in routine lab practices seem reasonable.

a. Validated method adoption

One possibility is for a lab to adopt a published, evaluated method. Such an adoption would require an initial establishment of the method within the lab's capabilities. Equivalence to the published method would be established during this initial phase. Thereafter, the method's uncertainty as documented in the original publication would be claimed for the lab results. Ongoing analysis of a limited number of quality control samples would provide evidence that the method as implemented in the lab remains stable.

An example of this approach is the current practice in some labs that handle sorbent tubes to analyze about 4 lab blanks per set of field samples analyzed. The variability in the blank results are then continually compared to past lab performance so as to detect problems which may occur in analysis. Though the small number of degrees of freedom ($= 3$) does not give a tight figure on the uncertainty, it nevertheless gives assurance that the method is stable.

As a specific example of method evaluation data and documentation of an uncertainty budget, data from $n = 16$ exposures of diffusive samplers in a controlled environment are shown in Table 2. The evaluation is somewhat simplified for this example; a more comprehensive evaluation would also measure effects of wind velocity, humidity, temperature, and concentration time-dependence (potentially significant to diffusive monitoring). Analysis of these data can be handled by an ordinary calculator capable of computing means and standard deviations.



Note that the uncertainty ($T\hat{R}SD/\sqrt{n}$, where $n = 16$ is the number of measurements) in the *bias* is the value that accounts for residual *bias* due to imperfect correction. Very similarly, the uncertainty in the reference concentration is pooled to arrive at a combined uncertainty. Interestingly, neither of these two contributions corresponds to quantities that vary during sampler application subsequent to its initial evaluation. The background for documenting residual (uncorrectable) *bias* can be seen in *Technical Note 2* at the end of this chapter.

Table 2. Example of method evaluation and uncertainty budget

Evaluation of experimental results

The following are results from a simplified evaluation of a specific diffusive sampler for o-xylene. There were four experimental runs with four samplers each. The reference concentration set within the exposure chamber is denoted as \hat{C} having an assigned (Type B) relative uncertainty = 1%.

| Run | \hat{C} (ppm) | replicates (ppm) | $\Rightarrow T\hat{R}SD_{inter}[s/\hat{C}]$ | <i>biâs</i> |
|-----|-----------------|------------------|---|-------------|
| 1 | 123 | 139.2 | 2.6% | 14.0% |
| | | 138.2 | | |
| | | 138.6 | | |
| | | 145 | | |
| 2 | 101.1 | 108.3 | 1.8% | 9.2% |
| | | 110 | | |
| | | 110.7 | | |
| | | 112.8 | | |
| 3 | 12.7 | 14.2 | 7.9% | 12.2% |
| | | 15.3 | | |
| | | 12.9 | | |
| | | 14.6 | | |
| 4 | 91.3 | 109 | 2.1% | 17.8% |
| | | 109.2 | | |
| | | 107.1 | | |
| | | 105 | | |

Averaging the above *bias* estimates and pooling the inter-sampler estimates $T\hat{R}SD_{inter}^2$ results in: Mean *bias* estimate: *biâs* = 13.3% from average of $4 \times 4 = 16$ data points. The *TRSD* estimate is $T\hat{R}SD_{inter} = 4.4\%$ having $4 \times 3 = 12$ degrees of freedom.

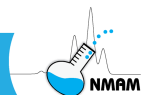
**Table 2. Continued****Uncertainty budget**

The following includes *bias* correction by dividing future concentration estimates by $(1 + \text{biâs})$ as in *Technical Note 2*.

| <i>Source</i> | <i>Component</i> | <i>Category</i> |
|------------------------------------|---|-----------------|
| Inter-sampler | 3.9% [= 4.4% / (1+.133)] | Type A |
| <i>Bias</i> Correction Uncertainty | 0.97% [= 3.9%/√16] | Type A |
| Ref Concentration Uncertainty | 0.5% [1%/√4, but not /(1 + <i>biâs</i>)] | Type B |
| Combined (Relative) Uncertainty | $u_c = \sqrt{3.9\%^2 + 0.97\%^2 + 0.5\%^2} =$ | 4.0% |
| Expanded (Relative) Uncertainty | $U = k \times u_c = 12.1\%$ ($k = 3$). | |

Notes: Here $k = 3.0$. A more accurate determination based on the chi-square quantile at 12 degrees of freedom and $\text{prob} = 0.05$, gives $k = 2.97$, which is consistent with conventional use of 3 as a conservative value.

Again, an expanded (relative) uncertainty U means that with greater than 95% of future *bias*-corrected estimates \hat{c} , true concentrations C are bracketed by:

$$\hat{c} x (1 - U) < C < \hat{c} x (1 + U),$$

at 95% confidence in the above evaluation experiment. Generally, a quality control program is required to ensure that the method remains stable following evaluation.

Note that many methods (e.g., those based on sorbent tubes) employ personal sampling pumps, in which case normally a 5% (Type B) component representing sampling pump uncertainty would be included in the uncertainty budget.

Note also that the inter-sampler component includes both analytical and sampling sub-components. Further refinement of the inter-sampler component may perhaps be useful for improving a method, but is not needed for establishing confidence intervals around (true) measurand values.

Note further that storage effects require estimating and inclusion in the budget if considered significant.

b. Pooled quality control results

Another approach utilizes a large number (e.g., 50) of the most recent quality control sample results. By pooling uncertainty values, a running method evaluation can be



effected. The result is (1) a direct measure of the analytical uncertainty of the method as implemented in the lab, and (2) a means of detecting any problems that may creep into a method during routine use. Note that a running uncertainty average is similar to a partial method evaluation and not to a method re-evaluation at each measurement because consecutive running averages are strongly correlated.

This approach is adopted within a current MSHA procedure for the analysis of silica. A sampling filter is dissolved and re-deposited onto an analysis filter where the silica is quantified by infrared absorption. From each batch of samples to be analyzed, an analysis filter is retained for re-dissolution, re-deposition, and re-analysis within a subsequent batch. The result is a large number of pairs of nearly identical samples, which can give a running estimate of the method's analytical uncertainty.

c. Continual method re-evaluation

A third possibility, the closest to the original measurement approach of GUM uses a large number (e.g., 30) of *independent control* samples for each application measurement. This is the most expensive approach, but also may give the best estimate of the analytical uncertainty, especially in cases where uncertainties may be measurement-dependent. Because many more evaluative measurements per application measurement are needed, this approach is not easily implemented for most industrial hygiene applications.

As an example of this approach [ISO 2002], suppose that a lab estimates only a 30-day average concentration of a given gas or vapor. Further, every day a measurement is taken of a known calibration gas concentration. Then, if the method is expected to behave similarly for measurements of gas and field samples calibrations, the 30 control samples give analytical uncertainty estimates that differ month-to-month and from field measurement to field measurement.

d. Limit of detection and detection limit

When the concentration is low, approaching the method uncertainty u_c , concepts of the limit of detection (*LOD*) and a related detection limit L_D may be useful. *LOD* is used for controlling false positives when asserting the presence of a substance. On the other hand, the detection limit specifies what measurand value (e.g., concentration) is required so that the false negative rate is negligible when the substance is actually present. The limits can refer to the analytical measurement only or, as in this section, to the entire sampling and analytical measurement method.

In the following examples, several often realistic assumptions are made. The standard deviation in concentration estimates is assumed constant (i.e., independent of the sampled



concentration), unlike the commonly occurring constant *relative* standard deviation at larger concentrations. Also, *bias* (or uncertainty in its correction) is assumed to be negligible. More complicated cases generally have specific difficulties that are best be approached by a statistician.

With these assumptions, in terms of the combined uncertainty u_c the limit of detection is traditionally [Keith et al. 1983; Currie 1997] taken to be:

$$LOD = 3 \times u_c, \quad (12)$$

and the detection limit may be defined as

$$L_D = 2 \times LOD. \quad (13)$$

Note that u_c includes the uncertainty associated with correction, if any, with blank subtractions. See ISO [2009] for a detailed example.

After LOD and L_D have been determined for a method they may be used as follows. A substance may be asserted as present if an estimate \hat{x} exceeds LOD . Moreover, if unknown (true) concentration X exceeds L_D , an estimate \hat{x} is likely to exceed LOD . Given the above definitions and assumptions, the false positive rate r on asserting presence is closely equal to the non-detection rate.

Note: If the combined uncertainty u_c is determined from a method evaluation providing an effective number ν (as in *Technical Note 2*) degrees of freedom, then at 95% confidence in the method evaluation, the false positive rate r is limited by:

$$r < 1 - \phi \left[3 \times \sqrt{\frac{\chi_{0.05,\nu}^2}{\nu}} \right], \quad (14)$$

where ϕ is the cumulative normal function. For example, if $\nu=15$, then $r < 3.5\%$.

5 Discussion

The approach presented here to document method accuracy range and uncertainty relates to the statistical theory [Bartley 2001; Wald and Wolfowitz 1946; Wilks 1941, 1942; Aitchison and Dunsmore 1975; CEN 2015; Smith 1936; Satherthwaite 1946] of *tolerance* or *prediction intervals*. This theory was originally developed in simplified form to predict the range of future measurements of a normally distributed random variable on the basis of n initial



measurements. The *initial measurements* are analogous to the method evaluation, whereas the *future measurements* represent method application subsequent to evaluation.

Because of measurement cost, workplace assessments cannot at present be conducted in such a way that continual re-evaluation is done at each measurement. The prediction interval approach given here shows a less costly way to document measurement uncertainty in those cases where a method has been initially evaluated and then used many times without re-evaluation. The approach closely follows ISO GUM. Of course, for such an approach to actually make sense, an adequate quality control program must be instituted so that the measurement method remains stable during the time of its application following evaluation.

Several generalizations and variations of the material presented in this chapter are possible. The relative standard deviation and relative *bias* sometimes depend on the concentration sampled in a complicated way, requiring special attention. See, for example Currie [1997]. Also, asymmetric confidence intervals are sometimes required. Single-sided intervals are useful in some instances, e.g., alarm systems, as well as in quantifying limits of detection or quantitation, described briefly above. Ways to handle environmental influence parameters may also be complicated. See, for example ASTM [2013a]. In any case, despite the complexities possible, the examples given in this chapter may help to characterize method uncertainty in a reasonable manner. For additional examples and explanations, see Appendices A and D of Components for Evaluation of Direct-Reading Monitors for Gases and Vapors [NIOSH 2012] and ASTM standards on accuracy and uncertainty [ASTM 2014, 2015].

6 Technical notes

a. Note 1: Example of accuracy range confidence limit:

Suppose it is known that the *bias* is zero. For example, an exposure standard may be set that specifies a given sampling and analytical method. In this case, the hazardous concentration may be said to be *operationally defined*. Operationally defined methods include NIOSH Methods 7400 and NIOSH 5040.

If the *bias* is zero, Eq. 6 simplifies to:

$$A = 1.960 \times TRSD.$$

Furthermore, if the relative standard deviation is estimated as $TR\hat{RSD}$ with ν degrees of freedom (computed using the Smith-Satterthwaite approximation [ISO 2010; Hald 1952;

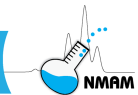

Wald 1942] if $TRSD$ has more than one component), then the 95% confidence limit on $TRSD$ is:

$$TRSD_{95\%} = TR\hat{S}D \times \sqrt{\frac{v}{\chi_{v,0.05}^2}},$$

where $\chi_{v,0.05}^2$ is a 5% quantile value for the chi-square distribution, which can be read from a table in most elementary statistics texts. This determines the 95% confidence limit on the accuracy range itself as:

$$A_{95\%} = \hat{A} \times \sqrt{\frac{v}{\chi_{v,0.05}^2}}.$$

If $v = 15$, $\sqrt{\frac{v}{\chi_{v,0.05}^2}}$ giving coverage factor $k = 2.8$ (Eq. 11).

Note that $TRSD_{95\%}$ can be interpreted as a conservative estimate of $TRSD$ and therefore can be treated as a Type B uncertainty with infinite number of degrees of freedom as described following Table 1.

b. Note 2: Single-evaluation correction of *bias*.

Details are given here illustrating the tolerance interval approach, *bias* correction, imprecise reference concentrations, and the use of the symmetric accuracy range function. The derivation is not entirely general, but is given here for guidance in handling the myriad possibilities in measurement uncertainty. Though the derivation is slightly complicated, the result obtained is simple.

Suppose that estimates \hat{c} having an as-yet-unknown constant *bias* relative to true concentrations C (not necessarily constant) may be modeled as:

$$\hat{c} = C \cdot [1 + \textit{bias} + \hat{\varepsilon}],$$

where the random variable $\hat{\varepsilon}$ is approximately normally distributed about zero with variance $TRSD^2$. For evaluating the method, assume that reference concentration measurements \hat{C} can be made simultaneously and modeled by:

$$\hat{C} = C \cdot [1 + \hat{\varepsilon}_{ref}],$$

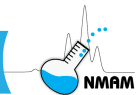

where $\hat{\varepsilon}_{ref}$ has variance $TRSD_{ref}^2$ assumed known accurately. Measure n values of the ratio $\hat{\theta}$:

$$\hat{\theta} \equiv \frac{c}{\hat{c}} = 1 + bias + \hat{\varepsilon}_c$$

and compute estimates $bi\hat{a}s$ and $\overline{TRSD_c^2}$ at $\nu = n-1$ degrees of freedom, where the approximately normally distributed random variable $\hat{\varepsilon}_c$ has variance $\overline{TRSD_c^2}$ given by:

$$TRSD_c^2 = TRSD^2 + (1 + bi\hat{a}s)^2 \times TRSD_{ref}^2$$

(to the order of $TRSD$, neglecting Cauchy effects of reciprocals of random variables).

Future *bias*-corrected measurements \hat{x}' of unknown concentration X can be defined in terms of raw measured values \hat{x} as:

$$\hat{x}' \equiv \frac{\hat{x}}{1 + bi\hat{a}s}.$$

The residual corrected *bias'* is then given by:

$$bias' = \frac{bias - bi\hat{a}s}{1 + bi\hat{a}s}$$

If n is large enough, $|bias'|$ will be small enough that the corrected symmetric accuracy range A' can be accurately approximated (Eq. 6) as:

$$A'^2 = \frac{a^2 1.960^2}{(1 + bi\hat{a}s)^2},$$

where the unknown a^2 is:

$$a^2 = (bias - bi\hat{a}s)^2 + TRSD^2,$$

whose confidence limit is now required.

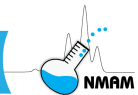

First note that the expected value of the first term is:

$$E[(bias - bi\hat{a}s)^2] = \frac{TRSD_c^2}{n}.$$

Therefore, an estimate \hat{a}^2 for a^2 can be constructed as:

$$\hat{a}^2 \equiv \frac{T\hat{R}SD_c^2}{n} + T\hat{R}SD^2$$

$$T\hat{R}SD^2 \equiv T\hat{R}SD_c^2 - (1 + bi\hat{a}s)^2 \times TRSD_{ref}^2.$$

Expressed in terms of $T\hat{R}SD^2$, \hat{a}^2 is:

$$\hat{a}^2 = T\hat{R}SD^2$$

$$+ \frac{1}{n}T\hat{R}SD^2$$

$$+ \frac{1}{n} \cdot (1 + bi\hat{a}s)^2 \times TRSD_{ref}^2.$$

Each term can now be identified, forming the basis for an uncertainty budget: the first is the (uncorrected) method uncertainty (squared); the second and third reflect the *bias*-correction uncertainty owing to finiteness of the validation experiment and the uncertainty in the reference concentration (as here measured n times).

A confidence limit a_β^2 at confidence level β (e.g., 95%) on a^2 is now constructed using \hat{a}^2 :

$$a_\beta^2 = K^2 \cdot \hat{a}^2,$$

where the constant K is to be determined so that

$$prob\{a_\beta^2 < a^2\} = 1 - \beta.$$

First of all, the distribution of \hat{a}^2 is approximated as chi-square:

$$v_{eff} \frac{\hat{a}^2}{E[\hat{a}^2]} \approx \chi^2,$$

where v_{eff} is determined as with the Smith-Satterthwaite [Keith et al. 1983; Currie 1997] approximation, forcing variances to agree; often $v_{eff} \approx n - 1$.

Now,

$$a_\beta^2 < a^2 \Leftrightarrow \hat{a}^2 < K^{-2}a^2,$$

or, in other words:

$$\chi^2 < \frac{v_{eff}(K^{-2}a^2)}{E[a^2]}.$$

[Note that, $E[\hat{a}^2] = E[a^2]$, but $\neq a^2$ unlike *Technical Note 3*.]

Remembering that a^2 depends on the estimate $bi\hat{a}s$, K is given as a solution of the following integral equation:

$$\begin{aligned} 1 - \beta &= \int_{-\infty}^{+\infty} dbi\hat{a}s P[bi\hat{a}s] \int_0^{v_{eff} \cdot K^{-2} \cdot a^{-2} / E[a^2]} d\chi^2 P_{v_{eff}}[\chi^2] \\ &= \int_0^{v_{eff} \cdot K^{-2}} d\chi^2 P_{v_{eff}}[\chi^2] \times (1 + O[1/n^2]), \end{aligned}$$

where the correction $O[1/n^2]$ is easily proved by expanding the integrand about $TRSD_c^2$ in $(bi\hat{a}s - bias)^2$. Therefore, the following simple asymptotic expression for K^2 results:

$$K^2 \approx \frac{v_{eff}}{\chi_{1-\beta, v_{eff}}^2}.$$

Thus, the coverage factor k is approximated as:

$$k \approx 1.960 \cdot \sqrt{\frac{v_{eff}}{\chi_{1-\beta, v_{eff}}^2}},$$

which is less than and close to 3.0, if the effective number of degrees of freedom $v_{eff} \geq 12$, and $\beta=0.95$.

In summary, the *bias* uncertainty is pooled together with the uncertainty components in $TRSD^2$. It should be remembered, however, that only $TRSD$ refers to quantities, which vary at each of the future measurements following the initial evaluation.

c. Note 3: Characterizing effects of uncorrected *bias*:

If the systematic error (*bias*) is non-zero, confidence limits on the accuracy range A may be approximated as follows. The Smith-Satterthwaite approximation is generalized in approximating estimates \hat{A} in terms of a chi-square random variable χ_v^2 for the two cases in Eq 6 by:

$$\frac{\hat{A}}{A} = \sqrt{\frac{\chi_v^2}{v}}, \text{ if } |bias| < \frac{RSD}{1.645};$$

$$\frac{\hat{A}}{A} = \frac{\chi_v^2}{v}, \text{ otherwise}$$

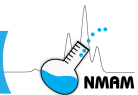

The effective number of degrees of freedom ν is determined by forcing the variance of χ^2_ν to reproduce the estimated variance of \hat{A}^2 or \hat{A} in their respective cases:

$$\nu = \frac{2A^4}{\text{var}[\hat{A}^2]}, \text{ if } |\text{bias}| < \frac{RSD}{1.645};$$

$$\nu = \frac{2A^2}{\text{var}[\hat{A}]}, \text{ otherwise}$$

Calculation of $\text{var}[\hat{A}^2]$ or $\text{var}[\hat{A}]$ is generally straightforward and depends on specifics of the evaluation experiment and on significant influence parameters. The confidence limit $A_{95\%}$ is then determined as in Eq 9:

$$A_{95\%} = \hat{A} \times \sqrt{\frac{\nu}{\chi^2_{0.05,\nu}}}, \text{ if } |\text{bias}| < \frac{RSD}{1.645};$$

$$A_{95\%} = \hat{A} \times \frac{\nu}{\chi^2_{0.05,\nu}}, \text{ otherwise}$$

This expression has been found [Bartley and Irwin 2002] quite accurate, exhibiting negligible effects from the discontinuity: The chi-square approximation is expected to be worst when $|\text{bias}|$ is large relative to $TRSD$. As an example, suppose the uncertainty has the following components: 5% from pump error and also a 5% analytical relative standard deviation. Suppose $\text{bias} = 20\%$. Suppose bias and the analytical uncertainty are measured with $\nu = 15$ degrees of freedom. Then 10,000-point simulations indicate that the calculated $A_{95\%}$ is slightly conservative, giving 96% confidence.

Disclaimer

Mention of any company or product does not constitute endorsement by NIOSH. In addition, citations to websites external to NIOSH do not constitute NIOSH endorsement of the sponsoring organizations or their programs or products. Furthermore, NIOSH is not responsible for the content of these websites. All web addresses referenced in this document were accessible as of the publication date.



7 References

ACGIH [2015]. Appendix C: Particle size-selective sampling criteria for airborne particulate matter. In: 2015 TLVs® and BEIs®. Cincinnati, OH: American Conference of Governmental Industrial Hygienists.

Aitchison J, Dunsmore IR [1975]. Statistical prediction analysis, Cambridge, England: Cambridge University Press.

ASTM [2013a]. D6246-08(2013) Standard practice for evaluating the performance of diffusive samplers. West Conshohocken, Pennsylvania: American Society for Testing and Materials International (ASTM).

ASTM [2013b]. D6062-07(2012) Standard guide for personal samplers of health-related aerosol fractions. West Conshohocken, Pennsylvania, American Society for Testing and Materials International.

ASTM [2014]. D3670 Standard guide for determination of precision and bias of methods. West Conshohocken, Pennsylvania, American Society for Testing and Materials International.

ASTM [2015]. D7440 Standard practice for characterizing uncertainty in air quality measurements. West Conshohocken, Pennsylvania, American Society for Testing and Materials International.

Bartley DL [2001]. Definition and assessment of sampling and analytical accuracy. *Ann Occup Hyg* 45(5):357-364.

Bartley DL and Irwin KC [2001]. Accuracy in measurements using diffusive samplers. In: *Proceedings of the International Conference on Diffusive Samplers*, Montpellier, France, pp. 99-107.

Bartley DL [2004]. Reconciling traditional accuracy assessment with the ISO guide to the expression of uncertainty in measurement (ISO/GUM). *J Occup Environ Hyg* 1:D37-D41.

Busch KA [1977]. Appendix A: SCP Statistical Protocol. In: Taylor DG, Kupel RE, Bryant JM, eds. *Documentation of the NIOSH validation tests*. Cincinnati, OH: U.S. Department of Health, Education, and Welfare, Center for Disease Control, National Institute for Occupational Safety and Health, DHEW (NIOSH) Publication. No. 77-185, pp. 7-11.



CEN [1993]. CEN EN481:1993 Workplace atmospheres – size fraction definitions for measurement of airborne particles. Brussels, Belgium: European Standardization Committee.

CEN [2015] EN 482:2012+A1:2015 Workplace exposures - General requirements for the performance of procedures for the measurement of chemical agents. Brussels, Belgium: Comité Européen de Normalization.

Currie LA [1997]. Detection: international update, and some emerging dilemmas involving calibration, the blank, and multiple detection decisions. *Chemom Intell Lab Syst* 37(1):151-181.

Ellison SLR, Williams A eds. [2012]. *Eurachem/CITAC guide: Quantifying Uncertainty in Analytical Measurement*, 3rd edition, Eurachem.

Hald A [1952]. *A statistical theory with engineering applications*. New York: John Wiley & Sons.

ISO [1995]. Air quality–particle size fraction definitions for health-related sampling. ISO 7708:1995(en). Geneva, Switzerland: International Organization Standardization.

ISO [2002]. ISO 11222:2002 Air quality - determination of the uncertainty of the time average of air quality measurements. Geneva, Switzerland: International Organization for Standardization.

ISO [2005]. ISO/IEC 17025:2005 General requirements for the competence of testing and calibration laboratories. Geneva, Switzerland: International Organization for Standardization.

ISO [2009]. ISO 15767:2009 Workplace atmospheres - controlling and characterizing uncertainty in weighing collected aerosols. Geneva, Switzerland: International Organization for Standardization.

ISO [2010]. *Evaluation of measurement data - guide to the expression of uncertainty in measurement*. Geneva, Switzerland: International Organization for Standardization (ISO).

Keith LH, Crummett W, Deegan J Jr., Libby RA, Taylor JK, Wentler G [1983]. Principles of environmental analysis. *Anal Chem* 55(14):2210-2218.



NIOSH [2012]. Components for Evaluation of Direct-Reading Monitors for Gases and Vapors. Cincinnati, OH: U.S. Department of Health and Human Services, Centers for Disease Control and Prevention, National Institute for Occupational Safety and Health, DHHS (NIOSH) Publication No. 2012-162.

NIOSH [1995]. Guidelines for air sampling and analytical method development and evaluation. By Kennedy ER, Fischbach TJ, Song R, Eller PM and Shulman SA. Cincinnati, Ohio: U.S. Department of Health and Human Services, Centers for Disease Control and Prevention, National Institute for Occupational Safety and Health, DHHS (NIOSH) Publication No. 95-117.

Satterthwaite FE [1946]. An approximate distribution of estimates of variance components. *Biometrics Bulletin* 2(6):110-114.

Smith HF [1936]: The problem of comparing the results of two experiments with unequal errors. *Journal of the Council of Scientific and Industrial Research* 9:211-212.

Vaughn NP, Chalmers CP, Botham RA. [1990]. Field comparison of personal samplers for inhalable dust. *Ann Occup Hyg*, 34(6):553-573.

Wald A [1942]. Setting tolerance limits when the sample is large, *Ann Math Statist* 13(4):389-399.

Wald A [1943]. An extension of Wilk's method for setting tolerance limits. *Ann Math Statist* 14(1):45-55.

Wald A, Wolfowitz J [1946]. Tolerance limits for a normal distribution. *Ann Math Statist* 17(2):208-215.

Wilks SS [1941]. Determination of sample sizes for setting tolerance intervals. *Ann Math Statist* 12(1):91-96.

Wilks SS [1942]. Statistical prediction with special reference to the problem of tolerance limits. *Ann Math Statist* 13(4):400-409.

8 Terminology

A — *symmetric accuracy range*, relative (%) range of 95% of a method's measurements about the (true) measurand

*A*_{95%} — 95% confidence limit on the symmetric accuracy range

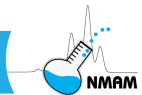

$bias$ — mean concentration estimate $bias$ relative to the (true) measurand

$bi\hat{a}s$ — bias estimate

\hat{c} — concentration estimate

C — true concentration

\hat{C} — reference concentration (estimate)

k — *coverage factor*, a constant containing confidence information for obtaining the expanded uncertainty U as a factor of the combined uncertainty u_c

L_D — *detection limit* (for controlling false negatives)

LOD — *limit of detection* (for controlling false positives)

n — number of measurements in a method evaluation

s_j^2 — unbiased estimate of variance σ_j^2

σ_j^2 — j th population variance component

$TRSD$ — (true) relative standard deviation

u_j — j th *uncertainty* component, an estimated standard deviation

u_c — *combined uncertainty*, pooled uncertainty components

U — *expanded uncertainty*, a value giving intervals bracketing the (true) measurand at given confidence in the measurement and method evaluation

U_j — degrees of freedom in an estimate

$\chi_{v,0.05}^2$ — chi-square quantile. This quantity by definition exceeds the chi-square variable at probability = 5%. Note that many tables use the notation $\chi_{v,0.05}^2$ for this quantity.

In general, hats represent estimates. Primes indicate bias-corrected quantities.



NIOSH Manual of Analytical Methods (NMAM), 5th Edition

General Considerations for Sampling Airborne Contaminants

by **Charles S. McCammon, Ph.D., CIH** and **Mary Lynn Woebkenberg, Ph.D.**; recension by **Kevin Ashley, Ph.D., NIOSH**

| | | |
|----|---|-------|
| 1 | Choosing measurement methods and sampling media | SA-2 |
| 2 | Types and uses of solid sorbents | SA-3 |
| 3 | Types and uses of aerosol samplers | SA-5 |
| 4 | Factors affecting the collection of gases, vapors, and aerosols | SA-5 |
| 5 | Establishing sampling parameters | SA-7 |
| 6 | Bulk samples | SA-10 |
| 7 | Blanks | SA-11 |
| 8 | Direct-reading methods | SA-12 |
| 9 | Sampling Strategy | SA-13 |
| 10 | Sampling and calibration techniques | SA-13 |
| 11 | References | SA-20 |



**Centers for Disease Control
and Prevention**
National Institute for Occupational
Safety and Health

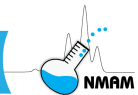

1 Choosing measurement methods and sampling media

In choosing methods for sampling of chemical and biological agents related to occupational exposures, thorough advance planning is required. Proper planning minimizes sampling and measurement costs while enabling the collection of high-quality data. Many criteria must be considered before collecting field samples from workplaces [ASTM International 2014]. The first step is to define the sampling objectives. These may include: a) documenting exposures in particular work settings; b) assessing compliance/non-compliance with existing regulatory or recommended occupational exposure limits (OELs); and/or c) determining sources of airborne contaminants. Sampling parameters that should be considered might include: a) type of sample (area vs. personal); b) contaminant(s) to be sampled; c) physical nature of airborne sample (vapor and/or aerosol); d) duration of sample collection; e) potential interferences; and f) estimated contaminant concentrations. Once these parameters are established, the suitable analytical method(s) and sampling media can be selected. For instance, when sampling for aerosols, the relevant particle size fraction to be sampled must be taken into account. Other general information needed to properly plan a sampling campaign include: a) the number of employees; b) the sampling strategy plan (discussed later); c) process flow diagram; d) safety data sheets on all process materials; and e) potential hazards involved in collecting and shipping field samples.

An accredited analytical laboratory should be used to conduct analysis of collected samples, and it is essential to consult with the analytical laboratory before sampling to ensure that the measurement methods available can meet the defined measurement needs. Consultation with the laboratory should be an early part of survey planning. The laboratory can also assist in choosing sampling media that are compatible with the sampling needs and the measurement methods available. The APPLICABILITY sections of the individual methods in NMAM can be helpful in choosing which of the available methods is best for a particular situation. Apart from NIOSH methods, methods from other organizations such as OSHA, ASTM International and ISO may be appropriate [Ashley 2015].

Whether through consultation with the laboratory or as cited in the relevant measurement method, the sampling media will be specifically identified. Methods will specify parameters such as: a) pore size and type of filter (for aerosol collection); b) concentration and amount of liquid media required (e.g., for impinger sampling or impregnation of filters); and c) type and amount of solid sorbent (for collection of gases / vapors); see below for common types and characteristics of various sampling media.



The physical state(s) of the contaminant(s) being sampled may also be a factor in determining the media required. In the case of polyaromatic hydrocarbons (PAHs), for example, the correct sampler consists of a membrane filter to collect particulate matter and a solid sorbent tube to trap the vapors of certain PAHs so that total collection is assured. Also, for sampling of gases and vapors, it is generally necessary to mount a prefilter in front of the gas/vapor collection media in order to trap aerosols that might otherwise interfere with subsequent analysis of target analytes.

The sampling pump used to collect the sample must also be compatible with the sampling needs and the media used. Specifically, the pump must be capable of maintaining the desired flow rate over the time period needed using the sampling media specified. Some pumps may not be able to handle the large pressure drop of the media. This may be the case for fine mesh solid sorbent tubes, small pore size filters or when attempting to take a short-term sample on a sorbent tube of a higher than normal pressure drop at higher flow rates. As a rule of thumb, higher-flow pumps (>1 L/min) can handle at least 3 kPa pressure drop at 1 L/min for 8 h. Some pumps can handle up to 7.5 kPa pressure drop at flows up to 5 L/min. Most low flow pumps (0.01 to 0.2 L/min) can handle the pressure drops of available sorbent tubes without problems, except that the nominal flow rate may decrease for certain models. All pumps should be calibrated with representative sampling media prior to use. It is good practice to check the pump calibration before and after use each day. As a minimum, calibration should be done before and after each use.

2 Types and uses of solid sorbents* [Melcher 1987]

a. Activated charcoal

By far the most commonly used solid sorbent is activated charcoal. This sampling medium is characterized by a very large surface area to weight ratio. It has a reactive surface and high adsorptive capacity. This surface reactivity means that activated charcoal is not useful for sampling reactive compounds (e.g., mercaptans, aldehydes) because of poor desorption efficiency. The high capacity, however, makes it the sorbent of choice for those compounds that are stable enough to be collected and recovered in high yield. Breakthrough capacity is a function of type (source) of the charcoal, its particle size and packing configuration in the sorbent bed. Humidity may affect the adsorption characteristics as well.

*NOTE: Solid sorbents are used for the collection of vapors only. Aerosols are not collected effectively by most sorbent beds, but may be collected by other components of the sampler (e.g., a prefilter).

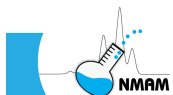

b. Silica gel

Silica gel is less reactive than charcoal. In part because of its polar nature, coated silica gel has been shown to be effective for sampling airborne ketones and aldehydes [Tejada 1986; García-Alonzo and Pérez-Pastor 1998].

c. Porous polymers

Porous polymers feature lower surface area and much less reactive surface than charcoal. Adsorptive capacity is, therefore, generally lower, but reactivity is much lower as well.

d. Synthetic sorbents

Synthetic carbonaceous sorbents demonstrate properties midway between charcoal and porous polymers.

e. Coated sorbents

Coated sorbents are those upon which a layer of a reagent has been deposited. The adsorptive capacity of such systems usually approaches the capacity of the reagent to react with the particular analyte of interest [Kennedy 1988].

f. Molecular sieves

Zeolites and carbon molecular sieves retain adsorbed species according to molecular size. A limiting factor is that the water molecule is of similar size to many small organic compounds and is usually many orders of magnitude higher in concentration than the species of interest. This unfavorable situation may result in the displacement of the analyte by water molecules. Drying tubes may be used during sampling to eliminate the effects of humidity [Langhorst 1983].

g. Thermal desorption

Thermal desorption tubes may contain several different sorbents in order to collect a wide range of different chemical agents [Hodgson et al. 1988]. These tubes are generally used in situations where unknown chemicals or a wide variety of organics are present, e.g., in indoor environmental air quality investigations. Subsequent analysis is often by gas chromatography/mass spectrometry (GC/MS).



3 Types and uses of aerosol samplers

[Baron 1998]

a. Membrane filters

By far the most frequently used as sampling media for aerosols are membrane filters. This class of filters includes those made from polyvinyl chloride, polytetrafluoroethylene (PTFE), copolymers, and mixed cellulose esters (MCE). Filters from this class are used for sampling airborne particles such as asbestos, crystalline silica, particulate PAH's, particles not otherwise regulated, and elements for atomic spectrometric analysis.

b. Glass and quartz fiber filters

Quartz filters have replaced glass fiber in many applications. They are used in applications such as sampling for mercaptans and diesel exhaust. Impregnated quartz filters are often used to sample reactive aerosols.

c. Polycarbonate straight pore filters

Because of their characteristics, polycarbonate filters are good for the collection of particles to be analyzed by electron microscopy and x-ray fluorescence.

d. Respirable dust samplers

Cyclone samplers are used to collect airborne respirable dust. For instance, a high-flow cyclone attached to a sampler containing a polyvinyl chloride filter is used to collect respirable crystalline silica.

e. Inhalable dust samplers

Various samplers have been designed and/or evaluated for collecting samples of inhalable airborne particles. For example, the Institute of Occupational Medicine's (IOM) sampler is used, in conjunction with a polyvinyl chloride filter, for sampling formaldehyde on dust [NIOSH 1994a].

4 Factors affecting the collection of gases, vapors, and aerosols

[Hebisch et al. 2009; Jones 1994; Baron 1994; Kulkarni et al. 2011]

a. Temperature

Since adsorption is typically exothermic, adsorption is generally reduced at higher temperatures. Additionally, if there is a reaction between an adsorbed species and the surface, or between two or more adsorbed species (e.g., hydrolysis or polymerization), the

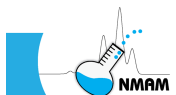

rate of such reactions increases at higher temperatures. The temperature stability of a filter must be considered when sampling in hot environments.

b. Humidity**

Water vapor is adsorbed by polar sorbents; their breakthrough capacity for the analyte is thereby reduced for most organic compounds. However, for water-soluble compounds, the breakthrough capacity is increased, e.g., for chlorine and bromine [Cassinelli 1991] and formaldehyde [NIOSH 1994b]. This effect varies from substantial for more polar sorbents, such as charcoal and silica gel, to a smaller effect for synthetic carbonaceous and porous polymers.

Filter media may also be affected by humidity; moisture may affect a filter's collection efficiency. Very low humidities ($\leq 10\%$ RH) may make some filters (e.g., MCE) develop high charge levels, causing non-uniform deposits and repulsion of particles [Chen and Baron 1996]. Water absorption by some filters (e.g., MCE) can cause difficulty in obtaining tare weights for gravimetric analysis; thus weight-stable filter materials must be used for this application.

c. Sampling flow rate**/face velocity

Breakthrough volume of a solid sorbent bed tends to be smaller at higher sampling flow rates, particularly for coated solid sorbents. For sorbents such as charcoal, whose breakthrough capacity for most organic compounds can be significantly reduced by high humidity, lower sampling flow rates may actually result in smaller breakthrough volumes [Foerst 1979]. The collection efficiency of membrane filters will change with face velocity.

d. Concentration**

As the concentration of contaminant in air increases, breakthrough capacity (mg adsorbed) of a solid sorbent bed increases, but breakthrough volume (L of air sampled) decreases [Foerst 1979]. The effect of concentration is similar for filters.

****NOTE:** It is important to distinguish between equilibrium (saturation) adsorptive capacity and kinetic (breakthrough) adsorptive capacity of the solid sorbent. Breakthrough capacity is the important characteristic in actual sampling situations; it may be affected significantly by sampling flow rate and relative humidity of the air being sampled and may be significantly less than saturation capacity, which is not dependent on sampling flow rate or relative humidity.



e. Particle characteristics

Filter collection efficiency is a function of effective pore size [Lee and Ramamurthi 1993]. Particles smaller than about 0.2 μm are collected primarily by diffusion, while particles larger than about 0.2 μm are collected primarily by impaction and interception. Most sampling filters are highly efficient (>95%) for all particle sizes, with the minimum efficiency in the 0.2 μm size range. Polycarbonate straight pore filters exhibit poor collection by diffusion, so particles smaller than the pores are not collected efficiently.

f. Filter considerations

The pressure drop of a filter can limit the sampling time because of the load on the personal sampling pump [Breuer 2012]. In addition, pressure drop increases with dust loading on the filter [Lippman 1995]. Fine particles (<0.5 μm) will increase the pressure drop much faster than coarse particles (>10 μm). Heavy loading (> about 2 mg) may result in poor adhesion of collected particles to the filter surface.

5 Establishing sampling parameters

Once the sampling media and measurement method are chosen, the specific sampling parameters need to be determined [Eller 1986; ASTM International 2013]. For most methods, this will not pose a problem as the flow rate recommended in the method can be used for the desired sampling period, e.g., 1 to 5 L/min for 8 h for most aerosols or 10 to 200 mL/min for 8 h for most sorbent tube samples. It is necessary to consider the applicable OEL for short-term (e.g., 15 min) or long-term (e.g., 8 h) time-weighted average (TWA) sampling. Generally, the parameters which must be considered are flow rate, total sample volume, sampling time (tied into the two previous parameters), and limit of quantitation (LOQ). Some of these variables will be fixed by sampling needs, e.g., sampling time or by the measurement method of choice (LOQ or maximum sampling volumes). The choice of these variables can best be explained through the use of the following examples.

a. Sampling for gases and vapors using solid sorbents

NIOSH Method: 1453 for Vinyl Acetate [NIOSH 2013]

Recommended Sample Volume: 1.5 – 24 L

Applicable Range: 0.07 to 46 mg/m^3 (0.02 to 13.1 ppm)

NIOSH REL: 14 mg/m^3 (4 ppm) - Ceiling

17.5 mg/m^3 (5 ppm) – (European OEL) TWA

Recommended Flow Rate: 0.05 to 0.2 L/min

Breakthrough Time: 30 min @ 0.2 L/min and 150 mg/m^3

Breakthrough Capacity: 9 mg

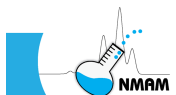

Suppose it is desired to determine both ceiling and TWA exposures of workers exposed to vinyl acetate and the concentrations are unknown.

1.) Ceiling Determination:

If sampling were done at 0.2 L/min for 30 min and a total sample volume of 6 L collected, would this present a breakthrough problem? Probably not, since breakthrough tests were carried out in concentrations ca. 10x above the NIOSH Ceiling value [NIOSH 2013]. In the breakthrough test, a concentration of 10 times the NIOSH Ceiling value (150 mg/m^3) was sampled at 0.2 L/min for 30 min (6 L) before breakthrough occurred, collecting a total weight of 9 mg of vinyl acetate. This test was conducted in a humid environment with only vinyl acetate present. A safety factor of 50% should normally be allowed to account for humidity effects. Thus, if sampling is done for about 15 min at 0.2 L/min, levels of vinyl acetate up to 40 ppm could still be collected without sample breakthrough.

Also to be considered are the other organics present. If a concentration of 200 ppm acetone exists in this environment, then an additional safety factor should be added. An arbitrary 50% reduction in sampling rate at 0.1 L/min might be done. With the safety factors built in, collecting a 6-L sample should be acceptable.

2.) TWA Determination:

In a similar situation, the goal is to collect 8-h samples for comparison to the 5 ppm TWA [NIOSH 2013]. If sampling were done at 0.1 L/min, then the total sample volume would be 48 L, substantially above the 24-L recommended sample volume. If the flow was dropped to 0.05 L/min, then the sample volume would be halved (to 24 L, the maximum recommended in the method). This sample volume might be acceptable if the vinyl acetate concentrations are around 10 ppm and no other competing organics are present, e.g., acetone. However, the safer approach would be to collect two consecutive samples at 0.05 L/min for 4 h (total sample volume of 12 L each).

b. Pushing a method to the limit – limit of quantitation

NIOSH Method 1009 for Vinyl Bromide (VB) [NIOSH 1994c]

Recommended Sample Volume: <10 L @ 0.20 L/min or less

Working Range: 0.3 to 33 ppm (1.3 to 145 mg/m^3) for a 6-L air sample;

this equals 8 to 355 μg VB per tube

Limit of Detection: 3 μg VB per tube

In this particular example, let us say that the object is to estimate exposure down to 0.1 ppm (0.44 mg/m^3), which is below the working range. In order to collect 8 μg of vinyl



bromide (the limit of quantitation) at this concentration, 20 L of air will have to be collected. This volume is substantially above the maximum recommended sample volume of 10 L. Since the recommended sample volume is generally a conservative value used to protect against breakthrough under worst case conditions (i.e., high humidity and high concentrations), considerable leeway exists for the size of the air sample. In this example, the 20-L air samples should be taken at 0.2 L/min or lower, and the possibility of breakthrough should be monitored by observing the relative amounts of analyte on the backup sections of the samples.

The best approach is to consult with the analytical laboratory and then to take a sufficient number of samples to determine the useful limits of the sampler in the particular application. The presence of high relative humidity and other organic solvents will severely reduce the number of active sites available on the sorbent for collection of the contaminant of interest (with concomitant breakthrough a concern). In pushing a method to the limit, it is often necessary to sample beyond the breakthrough volume, normally while observing recommended maximum sampling flow rate, in order to obtain the sensitivity to determine the concentration of interest. If this is done, then the risk must be accepted that the method may not apply outside the limits tested.

c. Sampling for aerosols using a filter

NIOSH Method 7908: Non-volatile Acids (Sulfuric and Phosphoric Acids)
[NIOSH 2014]

Recommended Sample Volume: 15 – 2000 L

Applicable Range of the Method: 0.010 to > 10 mg/m³

NIOSH REL: 1 mg/m³ (H₃PO₄) (TWA); 3 mg/m³ (STEL)

Recommended Flow Rate: 1 to 5 L/min

Suppose it is desired to determine both an exposure taking place during a specific 15-minute operation as well as a TWA exposure of workers exposed to phosphoric acid, and the concentrations are unknown.

1.) 15-Minute Process Sample:

This sample would meet the method conditions by sampling for the 15 minutes at 5 L/min, since this would collect 75 L. Sampling at 1 L/min for 15 minutes would probably not allow for the collection of sufficient sample required for analysis.



2.) TWA Determination:

In this situation, it is necessary to collect an 8-h sample to compare with the 1 mg/m^3 NIOSH REL. Since an 8-h TWA sample covers 480 minutes, sampling can no longer be done at 5 L/min since this would collect >2000 L, in excess of the upper recommended sample volume. Sampling at 1 L/min would collect a 480 L sample, and sampling at 2 L/min would collect a 960 L sample: both acceptable per the conditions of the method.

6 Bulk samples

The collection of bulk samples can often assist with air sampling efforts. This is especially true where there is mixed solvent exposure or unknown dust exposure, and for determining silica content of dusts. The primary purpose of obtaining bulk samples is to provide the analytical laboratory with a large enough sample for qualitative and sometimes quantitative analysis. The two main types of bulk samples are bulk air and mass bulk (liquid or solid) samples.

a. Bulk air samples

Generally, a bulk air sample is defined as a large volume area sample collected for the purpose of qualitative analysis. A good example is a multiple solvent exposure where the exact identity of the airborne solvents is unknown, e.g., painting operations. For most organic solvents, a bulk air sample consists of a sorbent tube collected at 1 L/min for an hour or more. Although the sample is likely to exhibit breakthrough, this does not matter since one is primarily interested in identifying which substances are present rather than their exact concentrations (the latter aim is accomplished through the separate collection of air samples in accordance with defined method parameters). Any questions concerning how or whether or not a bulk air sample is needed should be addressed to the analytical laboratory prior to sampling. In the case of silica sampling, either a bulk air or solid bulk sample (e.g., a deposited sample) or both are suggested so that enough material will be available to determine free silica content.

b. Bulk liquids and solids

Collection of bulk materials may be needed to identify the substances present in the workplace and, in some cases, to estimate the relative levels of certain substances present in the raw material. A good example of the latter is the case of mixed solvent exposure when determining whether a certain contaminant of interest is present, e.g., benzene. In some cases, up to 30 solvents may be present, but their identities and proportions are not certain. This example is also true for dusts, as was discussed previously for silica, and for metals, which may exist in trace quantities.



In choosing bulk samples for collection, the end goal must be considered: qualitative and/or quantitative analysis. Any information that can be given to the laboratory on what may or may not be present will help with the analysis. Advance consultation with the laboratory is desirable. In choosing bulk dust samples, the sample should be representative of the airborne dust to which the workers are being exposed. Usually this is a settled dust sample collected from locations near the workers' job site. In other cases, a process dust sample may be chosen to determine the composition of the material before it becomes airborne.

When shipping bulk samples, care must be taken to preserve the integrity of the samples and to follow established shipping regulations. If applicable, hazardous shipping procedures must be followed. Consult with an experienced hazardous goods shipper to determine appropriate protocol. Only 5 to 10 mL of the liquid or 10 to 100 mg solid is typically needed, so generally bulk sample sizes are kept small. It is important to consult with the laboratory before collecting bulk samples to ensure proper sample size and containers. In general, leak-proof glass containers are best since they will not react with most chemicals; however, polyethylene containers can be used in the majority of cases. A convenient container is a 20-mL scintillation vial with PTFE-lined cap. Specific chemicals for which polyethylene containers should not be used include aromatic compounds, chlorinated hydrocarbons and strong acids. The lids of the containers should be sealed with shrink bands or tape for further assurance against leakage. Specific restrictions and labeling requirements should be checked prior to shipping any samples.

In the case of volatile bulk samples (and some air samples), consideration should be given to shipping the samples on dry ice or with bagged refrigerant (e.g., "blue ice"). Do not ship volatile compounds together with air samples. Specific labeling is usually required when dry ice is used in shipping.

7 Blanks

Certain numbers of blanks are required by the analytical laboratory for each set of samples to be analyzed. The specific method being used should be consulted concerning the number and type of blanks required. There are two types of sampler blanks: field and media blanks. Field blanks are clean samplers taken to the sampling site, handled in the same way as the air samples, except that no air is drawn through them. Media blanks are simply unopened, new samplers which are sent to the laboratory with the field samples (these blanks are not usually taken to the field). It is also recommended that additional blind field blanks be sent along with the field samples, and labeled as field samples, as a further check on the analysis. Blanks are good insurance to deal with contamination, but the best approach is to avoid sample contamination by using careful sampling protocols. The general recommendation for the



number of field blanks is three field blanks for each batch of samples. Media blanks should also be included. These unexposed, unopened samplers are used to give an estimate of media background. The laboratory should analyze at least three (3) media blanks from the same lot as the field samples. This number should be increased for media which are coated or impregnated with reagent. Again, it is crucial to consult the specific method for the number and type of blanks as these numbers will vary. Another recommended practice is to include blind spiked samples as quality control checks of the analytical laboratory.

8 Direct-reading methods [Pearce and Coffey 2011]

The variety of types of direct-reading methods available is large and expanding, including detector tubes (both short- and long-term), aerosol monitors, passive monitors for certain gases and portable instrumentation for gas chromatography or infrared spectrometry [Todd 1997]. Many direct-reading instruments now used for personal or area measurements have evolved from laboratory or process control instruments [Woebkenberg and McCammon 1995; Todd 1997]. Some direct-reading instruments are screening devices while others give quantitative result and can be used for compliance purposes [Song et al. 2001; Ashley et al. 2002].

Some of the considerations (e.g., specificity and sensitivity) for the use of direct-reading methods for quantitative determinations are similar to those already given for filter or sorbent sampling and analytical methods. In many cases, direct-reading instruments, which are physically small and portable, qualify as personal sampling devices.*** These offer the additional advantages over classical methods by reducing labor and analytical costs and may be the methods of choice when instantaneous results are important, even at the expense of some degree of sensitivity or specificity. In general, manufacturers' instructions should be followed in the calibration and use of these devices. Because of the severe conditions to which direct-reading instruments may be subjected, performance checks and preventive maintenance on a periodic basis or before each use are very important. Many direct-reading instruments are powered by batteries which can fail to provide a full charge over the full sampling period unless frequently or fully discharged and recharged several times just prior to use. An additional responsibility, i.e., that of field calibration of the direct-reading instrument, falls on the field sampling personnel.

*****NOTE:** Portable instrument are generally described as weighing less than 5 kg and powered by self-contained batteries [Ashley 2003]. For personal monitoring, the instrument configuration should be such that the breathing zone can be monitored.

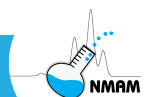

9 Sampling Strategy

To obtain the maximum amount of information during the course of a sampling campaign with a minimum number of samples, a statistical sampling strategy should be developed before conducting any study [Leidel et al. 1977; ASTM International 2013]. Several pieces of information must be known in advance to plan a sampling strategy, including the size of the workforce to be sampled, the accuracy of the sampling and measurement method to be used and the confidence one wishes to have in predicting the occupational exposures.

For example, to determine with 90% confidence that at least one worker from a workplace subgroup will be in the top 10% of the exposures occurring in the group, the number of employees to sample would be chosen from the scheme below. (Other figures are applicable for confidence limits of 95% and for the top 20% of exposures.) Again, judicious use of sampling statistics will optimize the number of samples needed.

Table 1. Minimum sample size (n) for including (@ 90% confidence level) at least one high risk employee^A [Leidel et al. 1977]

| Size of employee group (N) | | | | | | | | | | | | | | | | | | | |
|--|---|---|---|---|---|---|---|---|----|-------|-------|-------|-------|-------|-------|-------|-------|-------|-----|
| 1 | 2 | 3 | 4 | 5 | 6 | 7 | 8 | 9 | 10 | 11-12 | 13-14 | 15-17 | 18-20 | 21-24 | 25-29 | 30-37 | 39-29 | 40-49 | 50+ |
| Minimum number of measured employees (n) | | | | | | | | | | | | | | | | | | | |
| 1 | 2 | 3 | 4 | 5 | 6 | 7 | 7 | 8 | 9 | 10 | 11 | 12 | 13 | 14 | 15 | 16 | 17 | 18 | 22 |

^A Exposure in highest 10% of N.

10 Sampling and calibration techniques

The following are suggested general techniques for active sampling using some of the more common samplers. These instructions elaborate on those given in NIOSH methods. Consult individual methods for details regarding sample size.

a. Calibration of personal sampling pumps

The accuracy of determining the concentration of a toxic substance in air is no greater than the accuracy with which the air volume is measured. Therefore, accurate calibration of the airflow rate through the sampling train is necessary. Ordinarily, pumps should be calibrated in the laboratory and the field, both before field use and after each field sampling campaign.

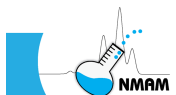

The choice of a reference instrument will depend on where the calibration is to be performed. For laboratory use, primary standards, such as a spirometer or soap-bubble meter, are recommended [Okladek 1988]. Several electronic soap-bubble calibrators and dry-cell calibrators are commercially available as primary calibrators. Other instruments, such as a wet-test, mass-flow or a dry-gas meter, may be used. The following instructions are for the soap-bubble meter. If another calibration device is used, equivalent procedures should be followed.

- 1.) Set up the apparatus as shown in Figure 1.
- 2.) Ensure that the rechargeable batteries will power the pump for the entire sampling interval by one of the following methods: 1) run the pump for that length of time, checking for satisfactory operation; or 2) test the battery independently of the pump using a current capacity tester [Kovein and Hentz 1988]. Fully recharge the batteries.
- 3.) Turn the pump on and moisten the inner surface of the soap-bubble meter with the soap solution. Draw bubbles upward until they travel the entire length of the buret without breaking.
- 4.) Adjust the pump to the desired nominal flow rate. Check the water manometer. The pressure drop across the sampler should not exceed 2.5 cm Hg of water.
- 5.) Start a soap bubble in the buret and, with a stopwatch, measure the time that it takes to traverse two calibration marks. For a 1000-mL buret, a convenient calibration volume is 500 mL. Repeat the determination at least twice more. Average the results and calculate the flow rate by dividing the calibration volume by the average time.
- 6.) Record the following data:
 - a. volume measured
 - b. elapsed time
 - c. pressure drop
 - d. air temperature
 - e. atmospheric pressure
 - f. serial number of the pump
 - g. pump model
 - h. date and name of operator.

- 7.) If the sampling pump used for sample collection uses a variable area flow meter (rotameter) for flow rate indication, the calibrated flow rate must be adjusted for the actual air pressure and temperature during sampling [Okladek 1988]. The expression for this correction is as follows.

NOTE: This correction is not used for non-rotameter sampling pumps.

V (Corrected volume, L) = $Q t (P_c T_s / P_s T_c)^{0.5}$ where:

Q = indicated flow rate (L/min)

t = sampling time (min)

P_c = pressure during calibration of sampling pump (kPa)

P_s = pressure of air sampled (same units as P_c)

T_c = temperature during calibration of sampling pump (K)

T_s = temperature of air sampled (K).

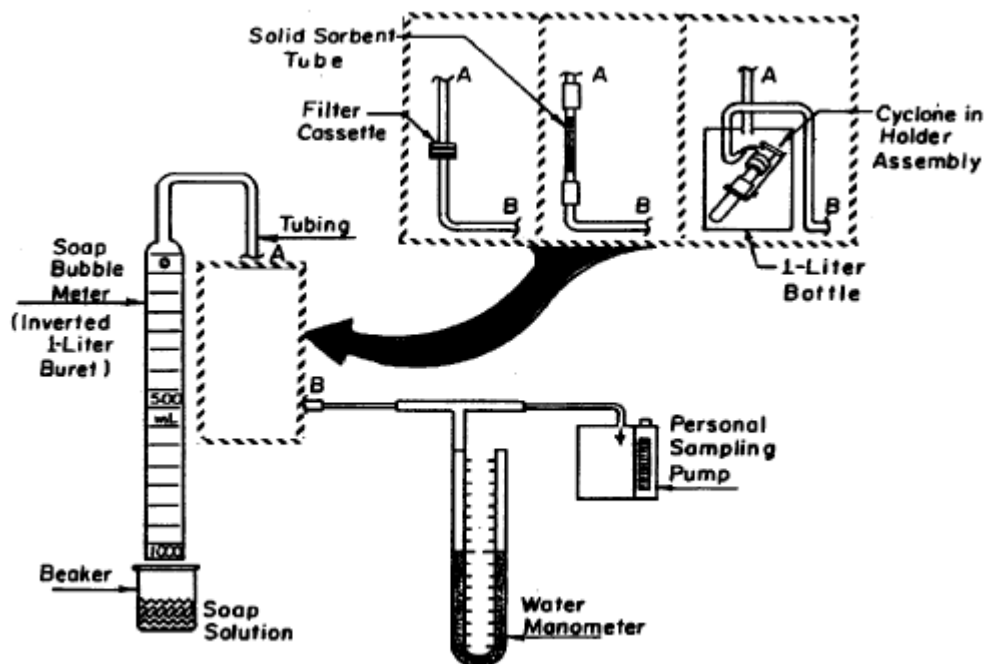
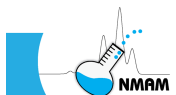

Figure 1. Calibration Apparatus

b. Sampling instructions for solid sorbent tube sampler

Use these instructions for active personal sampling (i.e., pumped sample airflow) for substances which are retained on solid sorbents such as activated charcoal, silica gel, porous polymers, etc.



- 1.) Calibrate each personal sampling pump at the desired flow rate with a representative solid sorbent tube in line. Use a bubble meter or equivalent flow measuring device.
- 2.) Break the ends of the solid sorbent tube immediately before sampling to provide an opening at least one-half of the internal diameter at each end.
- 3.) Connect the solid sorbent tube to a calibrated personal sampling pump with flexible tubing with the smaller sorbent section (backup section) nearer to the pump. Do not pass the air being sampled through any hose or tubing before entering the solid sorbent tube. Position the solid sorbent tube vertically during sampling to avoid channeling and premature breakthrough.
- 4.) Prepare the field blanks at about the same time as sampling is begun. These field blanks should consist of unused solid sorbent tubes from the same lot used for sample collection. Handle and ship the field blanks exactly as the samples (e.g., break the ends and seal with plastic caps) but do not draw air through the field blanks. A minimum of three field blanks are normally required for each batch of samples.
- 5.) Take the sample at an accurately known flow rate as specified in the method for the substance and for the specified air volume. Typical flow rates are in the range 0.01 to 0.2 L/min. Check the pump during sampling to determine that the flow rate has not changed. If sampling problems preclude the accurate measurement of air volume, discard the sample. Take a minimum of three replicate samples for quality control for each set of field samples.
- 6.) Record pertinent sampling data including location of sample, times of beginning and end of sampling, initial and final air temperatures, relative humidity and atmospheric pressure.
- 7.) Seal the ends of the tube immediately after sampling with plastic caps. Label each sample and blank clearly with waterproof identification.
- 8.) Pack the tubes tightly with adequate padding to minimize breakage for shipment to the laboratory. In addition to the sample tubes and field blanks, ship at least six unopened tubes to be used as media blanks and three additional tubes so that desorption efficiency studies can be performed on the same lot of sorbent used for sampling.

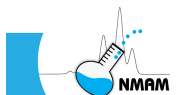

- 9.) Ship bulk samples in a separate package from the air samples to avoid contamination of the samples. If applicable, hazardous shipping procedures must be followed. Consult with an experienced hazardous goods shipper to determine appropriate protocol. Suitable containers for bulk samples are glass with a polytetrafluoroethylene (PTFE)-lined cap, e.g., 20-mL glass scintillation vials. It is important to consult with the laboratory before collecting bulk samples to ensure use of proper sample size and containers.

c. Sampling instructions for filter sampler

Use these instructions for personal sampling of inhalable aerosols. Methods requiring these instructions specify FILTER as the sampling method. These instructions are not intended for respirable aerosol sampling.

- 1.) Calibrate the personal sampling pump with a representative filter in line using a bubble meter or equivalent flow measuring device.
- 2.) Assemble a filter or internal capsule in a cassette filter holder. Support the filter by a cellulose backup pad or stainless steel screen. Close the filter holder to ensure that its parts mate evenly and securely to prevent leakage [Frazee and Tironi 1987]. Seal the filter holder with plastic tape or a shrinkable cellulose band.
- 3.) Remove the filter holder plugs and attach the filter holder to the personal sampling pump with a piece of flexible tubing. Position the filter holder in the worker's personal breathing zone, with the sampler inlet pointed downwards.
- 4.) Prepare the field blanks at about the same time as sampling is begun. These field blanks should consist of unused filters (or internal capsules) and filter holders from the same lot used for sample collection. Handle and ship the field blanks exactly as the samples, but do not draw air through the field blanks. Three field blanks are required for each batch of samples.
- 5.) Sample at the prescribed flow rate (usually 1 to 5 L/min) until the recommended sample volume is reached. Set the flow rate as accurately as possible (e.g., within $\pm 5\%$) using a calibrated flowmeter. Take three replicate samples (minimum) for quality control for each set of field samples.

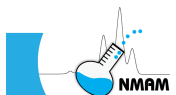

- 6.) Observe the sampler frequently and terminate sampling at the first evidence of excessive filter loading or change in personal sampling pump flow rate. (It is possible for a filter to become plugged by heavy particulate loading or by the presence of oil mists or other liquids in the air.)
- 7.) Disconnect the filter holder after sampling. Cap the inlet and outlet of the filter holder with plugs. Label the sample. Record pertinent sampling data, including times of beginning and end of sampling, initial and final air temperatures, relative humidity and atmospheric pressure. Record the type of personal sampling pump used and location of the sampler.
- 8.) Ship the samples to the laboratory as soon as possible in a suitable container designed to prevent damage in transit. Ship bulk material to the laboratory in a chemically inert container. Never store, transport or mail bulk samples in the same container as the samples or field blanks. In addition to the samples and field blanks, ship at least four unused filters or filter capsules from the same lot for use as media blanks.

d. Sampling instructions for filter + cyclone sampler

Use these instructions for personal sampling of respirable (or thoracic) aerosols [Frazee and Tironi 1987]. Methods requiring these instructions specify CYCLONE + FILTER as the sampling method.

- 1.) Calibrate the pump to the rate specified by the cyclone, with a representative cyclone sampler in line using a bubble meter (or a secondary flow measuring device which has been calibrated against a bubble meter). The calibration of the personal sampling pump should be done close to the same altitude where the sample will be taken.
- 2.) Assemble the pre-weighed filter in the cassette filter holder. Use a conductive or static-dissipative cassette. Support the filter with a cellulose backup pad or stainless steel screen. Close firmly to prevent sample leakage around the filter. Seal the filter holder with plastic tape or a shrinkable cellulose band.
- 3.) Remove the cyclone's grit cap and vortex finder before use and inspect the cyclone interior. If the inside is visibly scored, discard this cyclone since the dust separation characteristics of the cyclone might be altered. Clean the interior of the cyclone to prevent reentrainment of large particles.



- 4.) Assemble the two-piece filter holder, coupler, cyclone and sampling head. The sampling head rigidly holds together the cyclone and filter holder. Check and adjust the alignment of the filter holder and cyclone in the sampling head to prevent leakage. Connect the outlet of the sampling head to the personal sampling pump by a 1-m piece of 6-mm ID flexible tubing.
- 5.) Position the cyclone assembly in the worker's personal breathing zone and attach the personal sampling pump to a belt or harness. Ensure that the cyclone hangs vertically with the inlet pointed downwards. Explain to the worker that the cyclone must not be inverted.
- 6.) Prepare the field blanks at about the same time as sampling is begun. These field blanks should consist of unused filters and filter holders from the same lot used for sample collection. Handle and ship the field blanks exactly as the samples, but do not draw air through the field blanks. A minimum of three field blanks are required for each batch of samples.
- 7.) Turn on the pump and begin sample collection. If necessary, reset the flow rate to the pre-calibrated value, using the manufacturer's adjustment procedures. Since it is possible for a filter to become plugged by heavy particulate loading or by the presence of oil mists or other liquids in the air, observe the filter and personal sampling pump frequently to keep the flow rate within $\pm 5\%$ of the target flow rate. Sampling should be terminated at the first evidence of a problem.
- 8.) Disconnect the filter after sampling. Cap the inlet and outlet of the filter holder with plugs. Label the sample. Record pertinent sampling data, including times of beginning and end of sampling, initial and final air temperatures and atmospheric pressure or elevation above sea level. Record the type of personal sampling pump, filter, cyclone used and the location of the sampler.
- 9.) Ship the samples and field blanks to the laboratory in a suitable container designed to prevent damage in transit. Ship bulk samples in a separate package.
- 10.) Take a minimum of three replicate samples for every set of field samples to assure quality of the sampling procedures. The set of replicate samples should be exposed to the same dust environment, either in a laboratory dust chamber or in the field. The quality control samples must be taken with the same equipment, procedures and personnel used in the routine field samples. The relative standard deviation, sr,



calculated from these replicates, should be recorded on control charts and action taken when the precision is out of control.

Disclaimer

Mention of any company or product does not constitute endorsement by NIOSH. In addition, citations to websites external to NIOSH do not constitute NIOSH endorsement of the sponsoring organizations or their programs or products. Furthermore, NIOSH is not responsible for the content of these websites. All web addresses referenced in this document were accessible as of the publication date.

11 References

ACGIH [2015]. Threshold Limit Values for Chemical Substances and Physical Agents and Biological Exposure Indices. Cincinnati, OH: American Conference of Governmental Industrial Hygienists.

Ashley K, Song R, Schlecht PC [2002]. Performance criteria and characteristics of field screening test methods. *Am Lab* 34(12):32-39.

Ashley K [2003]. Field-portable spectroscopy. *Appl Occup Environ Hyg* 18:10-15.

Ashley K [2015]. Harmonization of NIOSH sampling and analytical methods with related international voluntary consensus standards. *J Occup Environ Hyg* 12:D107-D115.

ASTM International [2014]. ASTM E1370, Standard guide for air sampling strategies for worker and workplace protection. West Conshohocken, PA: ASTM International; www.astm.org. Date accessed: March 23, 2016.

Baron PA [1998]. Personal aerosol sampler design – A review. *Appl Occup Environ Hyg* 13:313-320.

Breuer D [2012]. Flow resistance of samplers for personal monitoring in work areas and requirements for sampling pump performance. *J Occup Environ Hyg* 9:D25-D32.

Cassinelli ME [1991]. Development of a solid sorbent monitoring method for chlorine and bromine with determination by ion chromatography. *Appl Occup Environ Hyg* 6:215-226.

Chen CC, Baron PA [1996]. Aspiration efficiency and wall deposition in the fiber sampling cassette. *Am Ind Hyg Assoc J* 52:142-152.



Eller PM [1986]. Operational limits of air analysis methods. *Appl Ind Hyg* 1(2):91- 94.

Foerst D [1979]. A sampling and analytical method for vinylidene chloride in air. *Am Ind Hyg Assoc J* 40:888-893.

Frazeo PR, Tironi G [1987]. A filter cassette assembly method for preventing bypass leakage. *Am Ind Hyg Assoc J* 48:176-180.

García-Alonzo S, Pérez-Pastor R [1998]. Use of C18 and silica-gel coated Sep-Pak cartridges for the determination of carbonyls in air by liquid chromatography. *Anal Chim Acta* 367:93-99.

Hodgson AT, Binenboym J, German JR [1988]. A multisorbent sampler for volatile organic compounds in indoor air. In: *Advances in air sampling (American Conference of Governmental Industrial Hygienists, ACGIH)*. Chelsea, MI: Lewis Publishers, pp. 143-157.

Hebisch R, Breuer D, Krämer W, Maschmeier C-P, Tschickardt M [2009]. Sampling and analysis of gases and vapours. In: *The MAK Collection, Part III – air monitoring methods, Vol. 11 (Deutsch Forschungsgemeinschaft, DFG)*. Weinheim, Germany: Wiley-VCH, pp. 13-47.

Jones FE [1994]. *Toxic organic vapors in the workplace*. Boca Raton, FL: Lewis Publishers.

Kennedy ER [1988]. Sampling reactive materials. In: *Advances in air sampling, ACGIH*. Chelsea, MI: Lewis Publishers, pp. 175-188.

Kovein RJ, Hentz PA [1988]. A digital current capacity tester for rechargeable batteries. *Appl Ind Hyg* 3(2):51-54.

Kulkarni PS, Baron PA, Willeke K, eds. [2011]. *Aerosol measurement – principles, techniques, and applications*. 3rd ed. Hoboken, NJ: Wiley.

Langhorst ML [1983]. A hollow fiber device for separating water vapor from organic vapors. *Am Ind Hyg Assoc J* 44:592-599.

Lee KW, Ramamurthi M [1993]. Filter Collection. In: Willeke KW, Baron PA, eds. *Aerosol measurement*. New York: Van Nostrand Reinhold.



Leidel NA, Busch KA, Lynch JR [1977]. Occupational Exposure Sampling Strategy Manual. Cincinnati, OH: U.S. Department of Health, Education, and Welfare, Center for Disease Control, National Institute for Occupational Safety and Health, DHEW (NIOSH) Publication No. 77-173.

Lippmann M [1995]. Filters and filter holders. In: Cohen BS, Hering SV, eds. Air sampling instruments. 8th ed.; Cincinnati, OH: ACGIH, pp. 247 - 278.

Melcher RG [1987]. Laboratory and field validation of solid sorbent samplers. In: Taylor JK, ed. Sampling and calibration for atmospheric measurements (ASTM STP 957). Philadelphia PA: American Society for Testing and Materials, pp. 149-165.

NIOSH [1994a]. Formaldehyde in dust: Method 5700. In: Eller PM, Cassinelli ME, eds. NIOSH manual of analytical methods (NMAM). 4th ed. Cincinnati, OH: U.S. Department of Health and Human Services, Centers for Disease Control and Prevention, National Institute for Occupational Safety and Health, DHHS (NIOSH) Publication No. 94-113 [www.cdc.gov/niosh/nmam/].

NIOSH [1994b]. Formaldehyde: Method 1206. In: Eller PM, Cassinelli ME, eds. NIOSH manual of analytical methods (NMAM). 4th ed. Cincinnati, OH: U.S. Department of Health and Human Services, Centers for Disease Control and Prevention, National Institute for Occupational Safety and Health, DHHS (NIOSH) Publication No. 94-113 [www.cdc.gov/niosh/nmam/].

NIOSH [1994c]. Vinyl Bromide: Method 1009. In: Eller PM, Cassinelli ME, eds. NIOSH manual of analytical methods (NMAM). 4th ed. Cincinnati, OH: U.S. Department of Health and Human Services, Centers for Disease Control and Prevention, National Institute for Occupational Safety and Health, DHHS (NIOSH) Publication No. 94-113 [www.cdc.gov/niosh/nmam/].

NIOSH [2013]. Vinyl Acetate: Method 1453. In: Ashley K, O'Connor PF, eds. NIOSH manual of analytical methods (NMAM), 5th ed. Cincinnati, OH: U.S. Department of Health and Human Services, Centers for Disease Control and Prevention, National Institute for Occupational Safety and Health, DHHS (NIOSH) Publication No. 2014-151 [www.cdc.gov/niosh/nmam/].

NIOSH [2014]. Non-Volatile Acids: Method 7908. In: Ashley K, O'Connor PF, eds. NIOSH manual of analytical methods (NMAM), 5th ed. Cincinnati, OH: U.S. Department of Health and Human Services, Centers for Disease Control and Prevention, National Institute for

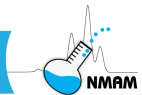

Occupational Safety and Health, DHHS (NIOSH) Publication No. 2014-151
[www.cdc.gov/niosh/nmam/].

Okladek J [1988]. An overview of flow metering devices. *Am Lab* 20:84-90.

Pearce T, Coffey C [2011]. Integrating direct-reading exposure assessment methods into industrial hygiene practice. *J Occup Environ Hyg* 8:D31-D36.

Song R, Schlecht PC, Ashley K [2001]. Field screening test methods – Performance criteria and performance characteristics. *J Hazard Mater* 83:29-39.

Tejada SB [1986]. Evaluation of silica gel cartridges coated in situ with acidified 2, 4-dinitrophenylhydrazine for sampling aldehydes and ketones in air. *Int J Environ Anal Chem* 26:167-185.

Todd LA [1997]. Direct-reading instruments for gases, vapors, and aerosols. In: DiNardi SR, ed. *The occupational environment – its evaluation and control*. Fairfax, VA: American Industrial Hygiene Association, pp. 177-208.

Wobkenberg ML, McCammon CS [1995]. Direct-reading gas and vapor Instruments. In: Cohen BS, Hering SV, eds. *Air sampling instruments*. 8th ed. Cincinnati, OH: ACGIH, pp 439-510.



Factors Affecting Aerosol Sampling

by Paul A. Baron, Ph.D., NIOSH

The NMAM team gratefully acknowledges Bon-Ki Ku, Kevin Ashley and Pramod Kulkarni for insightful review of this chapter.

| | | |
|----|---------------------------------------|---------|
| 1 | Introduction | AE - 2 |
| 2 | Inlet efficiency of the sampler | AE - 8 |
| 3 | Classifier accuracy | AE - 11 |
| 4 | Sampler assembly | AE - 15 |
| 5 | Electrostatic losses | AE - 16 |
| 6 | Sampler deposition uniformity | AE - 18 |
| 7 | Sampler wall losses | AE - 19 |
| 8 | Collection media and analytical issue | AE - 20 |
| 9 | Sampler field comparisons | AE - 22 |
| 10 | Conclusions | AE - 24 |
| 11 | References | AE - 25 |





1 Introduction

The need for aerosol sampling is driven by research or regulatory needs to understand or quantify the properties of airborne particles in the workplace or ambient environments. The property of most common interest is the airborne concentration of particulate mass defined as the aerosol mass per unit volume of air, usually expressed in units of micrograms or milligrams per cubic meter. Alternatively, concentrations of other related properties such as surface area or number, or particle size distributions are also of interest in certain cases, especially where exposure to nanoparticles or ultrafine aerosols are involved. In many applications, airborne concentration of a certain chemical or analyte, usually expressed in terms of micrograms per cubic meter, is more important. Aerosol sampling is the process of collecting a representative sample of airborne particles of interest from the air environment by physically separating them from the sampled air of known volume. The degree to which the physically separated sample represents the in situ aerosol depends on the design of the physical separation device, often known as the aerosol sampler. Other factors that affect the representativeness of the particulate sample include environmental conditions (e.g., wind, temperature, humidity), particle characteristics (particularly if they are highly irregular or nonspherical), and subsequent analytical methods used for particle analysis. This chapter focuses mainly on the key characteristics of aerosol samplers that may influence the representativeness of the sampled aerosol. Direct-reading aerosol samplers are not discussed in this chapter.

Most samplers use size-selective inlets that conform to certain health-based conventions. The American Conference of Governmental Industrial Hygienists (ACGIH) [Vincent 1999a; ACGIH 2015], the International Organization for Standardization (ISO) [ISO 1995], and the European Standardization Organization (Comité Européen de Normalisation, CEN) [CEN 1993] have adopted identical particle size-selective sampling conventions for inhalable, thoracic, and respirable aerosols (Figure 1). The purpose of these conventions is to provide a scientific basis for a new generation of particle size-selective occupational exposure limits (OELs) for aerosols. Such OELs can therefore be matched to the relevant sites of aerosol deposition after inhalation into the respiratory tract, and in turn to the health effects of interest in a given exposure assessment. These sampling conventions are used throughout this manual unless otherwise specified.

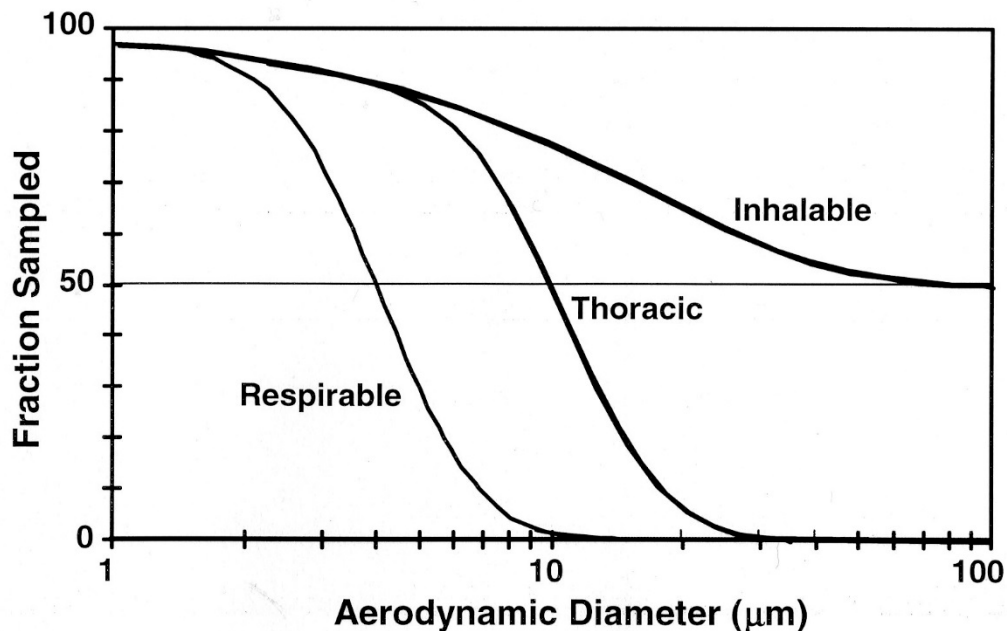

Figure 1. ISO/ACGIH/CEN sampling conventions [ISO 1995]. An ideal sampler should have a sampling efficiency curve that matches one of these curves as closely as possible under all wind directions and velocities. The 50% cut points for the respirable and thoracic conventions are 4 and 10 µm, respectively.

The criteria presented in this manual are used to determine the most appropriate aerosol sampling equipment. The type of sampling to be performed determines which criteria are important for estimating the adequacy of the sampler and determining aerosol concentration levels. For example, “total dust” samplers generally do not have a size selective particle classifier preceding the filter media and fall under the inhalable sampling convention. Alternatively, sampling for regulatory or voluntary compliance with aerosol exposure standards usually requires greater accuracy, increased efficiency, size-specific selectivity, and good analytical precision. Furthermore, regulations may require the use of a specific sampler and sampling conditions to standardize sampling results (eliminate bias) and reduce uncertainty among laboratory reports. See the chapter on measurement uncertainty and NIOSH method accuracy for further discussion on standardization and aerosol measurement error.

Open-face filter cassettes do not use constricted opening or tubing and expose the filter directly to the aerosol to minimize the losses. They provide relatively uniform particle deposition on the filter. On the other hand, closed-face filter cassettes are often necessary to connect to upstream tubing or size-selective inlets.

Over the past decades, researchers have pointed out strengths and weaknesses with several types of aerosol samplers (Figures 2A-J). Some of these samplers were adapted from existing devices used for other purposes, e.g., the 10-mm nylon cyclone and the 37-mm cassette, without the benefit of current testing technology and understanding of particle behavior.

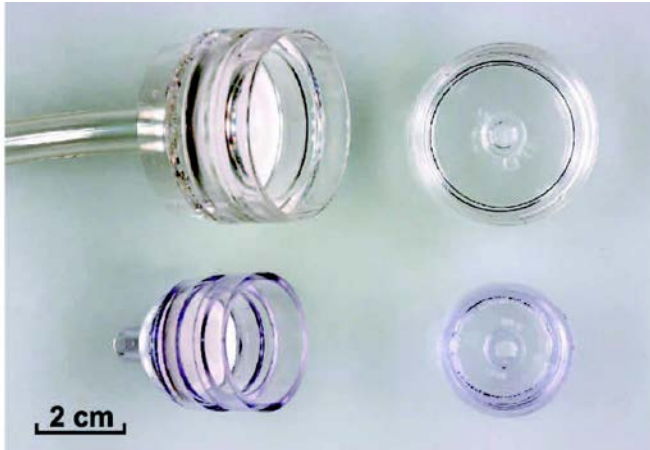

Figure 2A. 37-mm (top) and 25-mm (bottom) filter cassettes. Open faced cassettes are shown on left. Closed-faced cassettes include placement of clear piece (on right) over filter. These are shown in acrylic copolymer (clear, non-conducting) material and are more prone to electrostatic losses. Other construction materials are available, including conducting plastic. Sampling flow rates range from 0.5 to 10 L/min.



Figure 2B. IOM inhalable sampler. This is the first sampler designed specifically to match the inhalable sampling convention. The sampling cartridge is shown on the right with the inlet, filter, and support grid. All dust entering the cartridge is collected and analyzed. Sampler is made of conductive plastic and operates at 2 L/min.

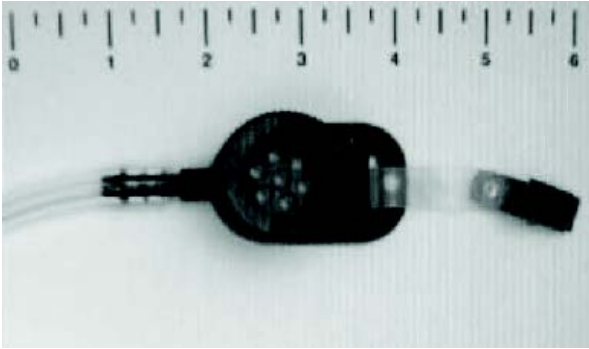

Figure 2C. Seven hole sampler used for inhalable dust sampling in the UK. Sampler is made of conductive plastic and operates at 2 L/min.



Figure 2D. Button sampler. So-named because the inlet, a hemispherical screen with ~380 μm diameter holes, resembles a large button. It was developed as an inhalable sampler with reduced wind direction response and improved filter deposit uniformity. The sampler uses metal construction and operates at 4 L/min.

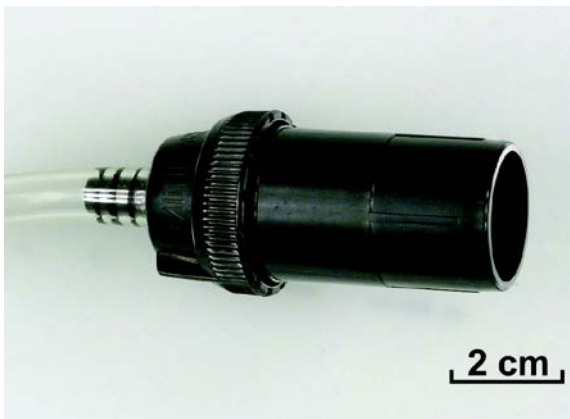

Figure 2E. Asbestos sampling cassette. The long (50 mm) inlet was designed to prevent incidental contact with the filter surface and, when facing downward, acts to a certain extent as an elutriator, preventing larger particles from reaching the filter surface. It is made of conductive plastic and is operated at a flow rate between 0.5 L/min to 16 L/min.



Figure 2F. Bell mouth cowl sampler. An alternative to the standard asbestos sampling cassette. The inlet is flared to reduce the effect of external air motion on sample uniformity. It is made of conductive plastic and is operated at a flow rate between 0.5 L/min to 16 L/min.



Figure 2G. Dorr-Oliver 10-mm nylon cyclone. It is used as a respirable sampler most often at 1.7 L/min. A version of this sampler is used at 2 L/min in coal mines with a 1.38 correction factor applied to the resultant mass. The holder encases body of the cyclone so that only the inlet section is visible just below the connection to the 37 mm cassette. The coal mine dust sampler version uses a cassette with an aluminum cartridge encasing the collection filter.



Figure 2H. Higgins-Dewell cyclone. This sampler was developed and used primarily as a respirable sampler in the UK. This version provides an interface directly to a 37-mm cassette. Cyclone construction is steel and operates at 2.2 L/min.



Figure 2I. GK2.69 cyclone. This cyclone was designed to match the slope of the thoracic and respirable conventions more closely than other sampling cyclones. Cyclone construction is stainless steel and operates at 4.2 L/min as a respirable sampler and 1.6 L/min as a thoracic sampler. GK4.162 RASCAL Cyclone is also available for higher flow rates of 8.5-9 L/min.



Figure 2J. Personal cascade impactor sampler (model Marple 290, Thermo Fisher Scientific). The sampler has five stages in the version shown and an additional three stages are available to provide cutpoints from 0.4 μm to 21 μm . The flap over the inlet reduces direct projection of large particles into the inlet. This sampler allows measurement of aerosol size distribution and calculation of respirable and thoracic fractions. It is constructed of aluminum and operates at 1.7 L/min.

More recently developed aerosol samplers were designed to either maximize the information gained regarding aerosol concentration levels or to minimize any inherent losses associated with the sampler design. Thus, each sampler design may have been based on some of the following criteria: inlet or aspiration efficiency, classifier accuracy, cassette assembly (bypass leakage), electrostatic losses, particle deposition uniformity, collection media stability, sampler surface losses, and sampler field comparisons. These criteria are discussed in the following sections of this chapter.

2 Inlet efficiency of the sampler

An important review of sampling theory and practice was compiled in a book by Vincent [2007]. The inlet efficiency of several samplers has been evaluated including thin-walled tubular inlets [Grinshpun et al. 1993], a cyclone [Cecala et al. 1983], an asbestos sampler [Chen and Baron 1996], total aerosol sampling cassettes [Fairchild et al. 1980], and inhalable aerosol samplers [Kenny et al. 1997; Aizenberg et al. 2001]. All samplers have an inlet efficiency, also called aspiration efficiency, which varies as a function of particle aerodynamic diameter, inlet velocity, inlet shape and dimensions, dimensions of the body it is attached to, external wind velocity, and external wind direction. The *aspiration efficiency* of an aerosol sampler can be defined as

$$A = \frac{C_s}{C_0}$$

where C_s is the concentration of particles passing directly through the plane of the sampling orifice and C_0 is the ambient concentration. This is true for aerosol samplers for which the entire amount of aerosol that enters the plane of the sampling orifice is quantified, as is the



case for the IOM sampler (SKC, Inc., Eighty Four, PA). However, it is important to note that many commercially available aerosol samplers use only the aerosol collected on the filter that is housed in the sampler, while any particles deposited on the inner surfaces upstream of the filter are disregarded. Performance of this type of sampler is therefore best characterized by its *sampling efficiency*, in which the aspiration efficiency is modified by the particle size-dependent wall losses prior to the filter. The aspiration or sampling efficiency of a particular aerosol sampler, whichever is the most relevant, expressed as a function of particle aerodynamic diameter, is the primary index of sampler performance. The overall size-dependent transmission efficiency of the sampler must match the appropriate health-based criterion (e.g., the inhalability criterion) to allow its use for a health-based assessment of personal aerosol exposure.

As an aerosol is being sampled, the large-particle trajectories are more affected by external flow fields than those of small particles. Thus, the shape, orientation, and inlet flow field will be most critical for inhalable aerosol sampler inlets; they will be less important for thoracic samplers and unlikely to be important for respirable samplers, except at very high wind velocities. The flow field near the inlet of a sampler is different when the sampler is mounted on a person (or in laboratory simulations using a mannequin) than when it is freestanding. Therefore, it has been recommended that measurement of inhalability be determined from mannequins in wind tunnels [Vincent 1999a; Kennedy et al. 1995; Kennedy and Hinds 2002; Aitken et al. 1999]. Flow field studies using mannequins in wind tunnels indicate that the air is slowed down by the body, resulting in an enrichment of large particles in the upstream side of the body [Rodes et al. 1995]. When intended for use at low wind speeds (less than about 1 m/s [200 ft/min] (representing most indoor workplaces), it may be possible to test the samplers as freestanding devices if it can be shown there is no effect from the mannequin body [CEN 1997]. However, if the sampler is to be used at higher windspeeds, which frequently occur outdoors, personal aerosol samplers should be evaluated on a mannequin in a wind tunnel [CEN 1997].

Respirable aerosol samplers generally do not have problems with inlet effects because the particles being sampled have low enough inertia and settling velocity. However, Cecala et al. [1983] found that the 10-mm nylon cyclone operated free-standing in a wind tunnel oversampled at external air velocities greater than 4 m/s when the inlet faced the wind and undersampled at 90° and 180° to the wind at velocities greater than 1 m/s. The maximum sampling error of about 40% was observed at 10 m/s. It is expected that these errors would be reduced if the sampler were located on a person, because the air velocity decreases near the body surface. It should be noted that the Cecala et al. work was conducted in the context of aerosol sampling in underground mining environments. Here, windspeeds of the magnitude quoted are not uncommon. However, in industrial workplaces more generally, windspeeds are much lower. Two surveys of a wide range of workplaces [Baldwin and Maynard 1998; Berry



and Froude 1989] revealed that actual indoor windspeeds rarely exceeded 0.2 to 0.3 m/s and more typically were less than 0.1 m/s.

The EPA PM₁₀ standard for environmental sampling specifies a sampler that has a 50% cutpoint at 10.6 μm particle diameter, approximately the same as that for the thoracic sampler [Baron and John 1999]. Although the requirements for environmental PM₁₀ samplers stipulate wind tunnel testing, similar work on personal PM₁₀ and thoracic samplers is yet to be performed. It is expected that these samplers will be more susceptible to wind effects than respirable samplers because larger particles are more susceptible to inertial and gravitational effects.

The most extensive comparison of available inhalable aerosol samplers was that carried out under the auspices of the European Commission (EC) [Kenny et al. 1997]. Eight samplers were tested: CIP-10 (foam-based, French); 37-mm closed-face cassette (Spain and US) (Figure 2A); 37-mm open-face cassette (Sweden) (Figure 2A); PAS-6 (Netherlands); PERSPEC (Italy); GSP (Germany, sold as CIS sampler in US; BGI, Inc. Waltham MA); IOM (United Kingdom; (Figure 2B); and the Seven-Hole Sampler (United Kingdom; Casella CEL, Inc., UK) (Figure 2C). Conditions of the experiment included measurement of sampler collection efficiencies on a mannequin for aerosol particles with diameters as large as 100 μm at a wind speed of 0.5m/s, 1.0 m/s, and 4 m/s. Samplers were positioned on a mannequin rotating within a wind tunnel. The samplers were all conductive; the 37-mm cassette samplers were painted with an external conductive coating. The aerosol was, however, not neutralized. The results of this experiment indicated high inter-sampler variability, but permitted estimates of bias relative to the inhalable convention. The EC study also indicated that most samplers work reasonably well at low wind speeds (<1 m/s) for particle median diameters below 25 μm [Kenny 1995]. The study indicated that experiments of this type were difficult, expensive, and generally had poor precision. Perhaps better understanding of the flow field near the body may lead the way to improved and simplified sampler testing. Recent work suggests ways of making the wind tunnel testing of inhalable samplers simpler and less expensive, e.g., by using a compact body to simulate the chest of a mannequin [Witschger et al. 1997] and by using miniaturized mannequins and samplers that are calculated to be aerodynamically equivalent [Ramachandran et al. 1998].

The orientation and diameter of an inhalable sampler inlet may affect the collection of very large particles (generally >100 μm), since these may be thrown into the inlet as projectiles. The current definition of inhalable aerosol only covers particles up to 100 μm aerodynamic diameter.

In situations where large particles can be generated (e.g., abrasive blasting, wood working, and grinding operations) excessive collection of particles up to the millimeter range is likely to



occur. There have been some attempts to modify inlets with shields to provide a barrier against the collection of large particles, but these modified inlets have not been demonstrated to provide the same agreement with the inhalable convention as the unmodified ones.

Another potential problem with inhalable samplers is the collection of passively sampled particles. Measurements when the sampler airflow is turned off indicate that IOM samplers, which pointed outward from the body and had a large inlet diameter (15-mm), can collect quite significant amounts of dust, with median values of 9 to 32 percent of the mass collected during active sampling [Lidén et al. 2000b]. Open-faced cassettes had only 2 to 11 percent of the mass passively collected. These samplers have a larger inlet (37-mm), but point downward, reducing the likelihood of particle settling onto the collection surface. The mechanism of collection is unclear, but the dust may be transported into the inlet by turbulence and deposited by settling or turbulent diffusion. How this passively collected dust modifies the amount collected during active sampling remains under investigation.

A comparison of measurements obtained with the 37-mm closed-face cassette (4-mm inlet diameter) to the IOM sampler (15-mm inlet diameter) in several workplaces gave similar results when the material on the interior walls of the 37-mm cassette were added to the analyte deposited on the filter [Demange et al. 2002; Harper and Demange 2007]. This suggests that the two samplers can have similar inlet efficiencies in spite of differences in inlet size and orientation if the median particle size sampled is not too large. Therefore, if the total aspiration (which includes the mass from filter and the wall deposits) of the IOM sampler conforms with the ISO inhalable size-selection criterion, then so does the total aspiration of the closed cassette filter. Several studies have now shown that in metals industries the total of mass from particulate filter and the wall deposit are comparable for both the closed cassette filter and the IOM samplers [Harper and Demange 2007].

3 Classifier accuracy

The theory of classifier separation is based on particle aerodynamic diameter, which is defined as the diameter of a 1 g/cm³ density sphere having the same gravitational settling velocity as the particle in question. If the particle is markedly nonspherical or irregularly shaped, the aerodynamic diameter may depend on particle's orientation and other factors, possibly contributing to sizing errors. For example, fibers and plate-like particles settle slightly differently depending on orientation [Kulkarni et al. 2011]. Thus, the sampling conventions, based on aerodynamic diameter of particles reaching specified parts of the respiratory system, become somewhat ambiguous for these types of particles. For such nonspherical particles, further testing of classifiers to simulate particle behavior in the respiratory tract may be necessary. For instance, Maynard [1996] found that plate-like particles may orient differently in elutriators, impactors, and cyclones. This preferred orientation in a cyclone produced a



collection efficiency 15% below that estimated to occur in the respiratory system. In addition, Baron et al. [2008] showed that the overall enveloping physical size of airborne single-walled carbon nanotube (SWCNT) agglomerates is much larger than their aerodynamic size, by a factor of up to 10. Ku and Kulkarni [2015] measured both aerodynamic and mobility (or diffusion) diameters of airborne carbon nanotubes (CNTs) and other nanomaterials to show that aerodynamic diameter is smaller by a factor of 2 to 4 than mobility diameter for SWCNT and multi-walled CNT particles. These studies indicate that relevant equivalent diameters must be used to obtain reliable estimation of lung deposition fraction. Improved understanding of fiber [Esmen and Erdal 1991], nanotube [Baron et al. 2008; Ku and Kulkarni, 2015] and plate-like particle [Maynard 1996] behavior in the respiratory tract is needed to aid in development of more accurate samplers for these types of particles. The phase (i.e. liquid or solid) of the aerosol particles also influences sampling errors. Koehler et al. [2012] examined the sampling efficiency as a function of particle phase of three personal aerosol samplers, including the IOM and button sampler. They found that large liquid droplets have low transmission efficiencies through the screened inlets and that the bounce of solid particles significantly affects the aspiration efficiencies of screened inlets.

Various types of classifiers have been constructed to meet the ACGIH/ISO conventions. For example, respirable samplers have used cyclones [Caplan et al. 1977], impactors [Marple 1978; Kimura 1978; John 1994], elutriators [Lynch 1970], and porous foam [Brown 1980; Courbon et al. 1988] to remove non-respirable particles from the aerosol prior to filter collection. The technology for testing these samplers has improved in recent years through use of a real-time aerodynamic sizing instrument and resulted in quicker and more precise measurements [Baron 1993; Gudmundsson and Lidén 1998]; this technique has allowed the accuracy of these samplers to be investigated more carefully [Bartley et al. 1994]. However, a round-robin comparison of 50% cut-point measurements from six laboratories using an aerodynamic sizing instrument to test the same cyclone agreed within a range of 11% [Lidén 2000a]. Further work on the testing protocol is needed to improve interlaboratory agreement. Many current classifiers do not match the shape of the respirable convention exactly and produce biases that depend on size distribution. Two comparisons of several respirable samplers have been performed using the aerodynamic sizing technique [Chen et al. 1999b; Görner et al. 2001].

The introduction of the thoracic fraction in the ACGIH/ISO conventions has spurred interest in thoracic classifiers for certain types of aerosols, e.g., cotton dust, asbestos and sulfuric acid [Baron and John 1999]. The performance characteristics of the vertical elutriator (operated at 7.4 L/min) used for cotton dust approximately meets the thoracic definition [Robert 1979]. Laboratories in many countries perform asbestos fiber measurement using the technique of counting only fibers with diameters of 3 μm or less; this size selection was shown to be approximately equivalent to thoracic sampling [Baron 1996]. Further tests indicate that



several thoracic samplers may be appropriate for asbestos sampling [Jones et al. 2001; Maynard 1999]. Thoracic sampling is also recommended for sulfuric acid [Lippmann et al. 1987] and metal working fluids [NIOSH 1998].

Several samplers based on inertial, cyclone and foam separators have been specifically developed to meet the thoracic definition [Fabriès et al. 1989; Fang and Lippmann 1995; Mark et al. 1988; Kenny and Gussman 1997]. The CIP-10 sampler has been used for thoracic sampling in Europe [Gorner et al. 1994], but is not applicable to aerosols with a significant submicrometer fraction [Fabriès et al. 1989]. Several of these samplers have been tested to compare with the thoracic convention [Jones et al. 2001; Maynard 1999]. The GK2.69 cyclone (Figure 2I) has been used for metal working fluids [NIOSH 1998] and GK4.162 cyclone has been used for measurement of crystalline silica [Qi et al., 2015]. Several developmental samplers have also been developed. Koehler and Volckens [2013] have developed multistage regional deposition sampler that allows estimation of regional deposition of aerosol in the human respiratory system. This sampler is not suitable for gravimetric analysis but is well suited for measurement using variety of chemical analyses. A personal nanoparticle respiratory deposition sampler was developed by Cena et al. [2011] for particles smaller than 300 nm diameter, whose aspiration efficiency curves matches the fractional International Commission on Radiological Protection (ICRP) deposition curve for human respiratory tract below ~300 nm. Tsai et al. [2012] have developed a personal nanoparticle sampler which simultaneously collects both respirable and nanoparticles fraction (<100 nm aerodynamic diameter).

The PM₁₀ standard for environmental sampling is very similar to the thoracic convention and impactors with a 10 µm cutoff size have been used for personal PM-10 sampling [Buckley et al. 1991]. A cascade impactor, e.g., the Andersen personal cascade impactor (Figure 2J), can be used to calculate the thoracic fraction of an aerosol. Although a thoracic sampler is commercially available (Figure 2I), further work is needed to determine its applicability for specific types of aerosol. For example, a thoracic sampler for fibers must result in a uniform deposit of the particles on the filter for accurate analysis results.

The overall accuracy of a classifier with respect to sampling in accordance with the one of the sampling conventions can be estimated using a bias map (Figure 3). The bias map displays the percent difference between the predicted mass collected by the sampler and the mass expected according to the convention as a function of the parameters of a lognormal particle diameter distribution for a range of likely workplace distributions. Such a bias map can be used for selecting a sampler for a workplace having a certain range of particle sizes or for developing samplers that agree more closely with the sampling conventions.

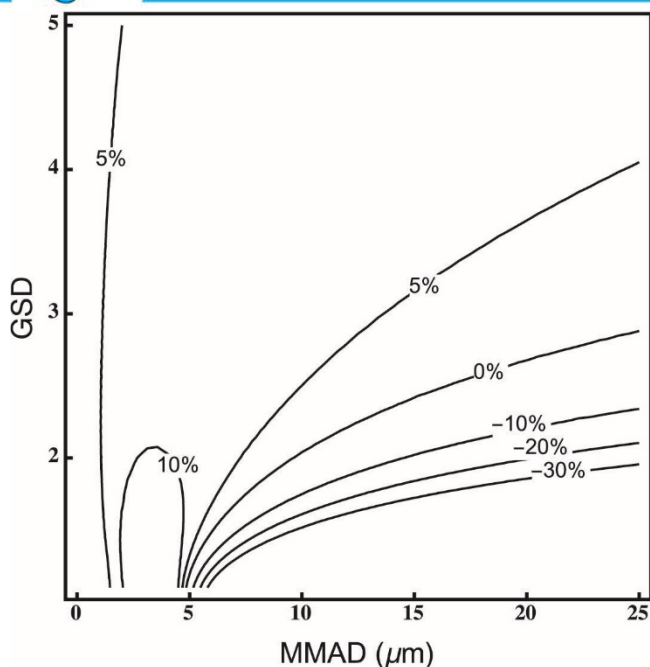

Figure 3. Bias map for the 10-mm nylon cyclone (operated at 1.7L/min) compared with the respirable convention [Courbon et al. 1988]. The contour lines represent percent bias for specific lognormal size distributions. The calculation of this map is based on laboratory measurement of cyclone penetration and can be used with field size distributions to estimate sampling bias.

The bias map in Figure 3 was created by: (a) fitting the penetration curve for the 10-mm nylon cyclone (Figure 2G) [Gudmundsson and Lidén 1998] at 1.7 L/min with a lognormal curve (a logistic curve also can be used), (b) calculating the bias between the respirable convention and the curve from the previous step for a range of lognormal size distributions, and (c) plotting the bias contour lines as a function of the size distribution mass median aerodynamic diameter (MMAD) and geometric standard deviation (GSD). The 10-mm nylon cyclone shows significant negative biases, especially at large MMADs and small GSDs, because the cyclone penetration curve drops off more rapidly with size than the curve for the respirable convention. The “best” flow rate to use in a workplace when sampling according to one of the conventions becomes a matter of judgment, depending on the size distribution typically encountered in that workplace. A cyclone that fits the convention more exactly will exhibit smaller biases throughout the entire size distribution range. Bias maps are available for several respirable samplers [Chen et al. 1999b; Görner et al. 2001]. It should be mentioned that in some cases, e.g., coal mine dust sampling, a single sampler is specified by regulation. This sampler specification eliminates the question of bias for that type of measurement.

Investigation of the effect of changing the physical dimensions of a commercial cyclone resulted in modifications that improved the match to the respirable sampling convention



[Lidén and Gudmundsson 1996]. Chen and coworkers developed a virtual cyclone that appeared to give excellent compliance with the respirable curve [Chen et al. 1999a]. It is possible to make samplers that have predicted biases less than 10% over the entire range of likely workplace size distributions. While the behavior of certain samplers, such as impactors, can be predicted theoretically, it is still important to measure penetration curves experimentally to ensure correct application of the theory. Bias maps based on these data then allow estimation of accuracy for a specific workplace application. As improved samplers are tested and become commercially available, more accurate thoracic and respirable aerosol measurement on a routine basis will be possible.

As mentioned above, several inhalable samplers were investigated in a wind tunnel to evaluate their sampling efficiency compared to the inhalable convention [Kenny et al. 1997]. Based on these data, sampler performance (maximum bias confidence limit) was ranked [Bartley 1998] and the IOM, GSP, and CIP-10 samplers were rated the best.

As interest in the new particle size-selective conventions by standards setting bodies has grown, efforts have been made to define protocols to guide the testing and validation process for available samplers. One approach was developed by the CEN [Lidén 1994; CEN 1998]. In the CEN model, for any given sampler to be tested, the first step is a critical review of the sampling process for the instrument in question. This is intended to identify factors that may influence the performance of the sampler, including particle size, windspeed, aerosol composition, filter material, etc. This is essential in the process of sampler evaluation, determining under what conditions the sampler will need to be tested. Three options are then presented for the testing of samplers: (a) the laboratory testing of samplers to compare performance with the sampling conventions, (b) the laboratory comparison of instruments, and (c) the field of comparison of instruments. Research projects have been conducted in recent years to define testing protocols (option a), funded both by the European Community and by NIOSH, to consolidate the scientific basis for such protocols and to identify improved and more cost-effective methods.

4 Sampler assembly

Some samplers are designed such that improper assembly can result in internal leakage, i.e., aerosol particles bypassing the filter. This bypass leakage has been noted in the 37-mm closed-face cassette [Frazee and Tironi 1987; Van den Heever 1994]. Although at least one study found no problem with hand assembly of these cassettes [Puskar et al. 1991], NIOSH and others have occasionally observed, after sampling black or colored dusts, streaks of dust on the filter's compression seal region or an incomplete compression mark, indicating aerosol leakage bypassing the filter. An airtight seal in these cassettes is achieved by compression of two plastic parts that must be parallel and joined with the proper force. If this seal is not



compressed with sufficient force, the vacuum behind the filter may pull the filter from the seal, especially at high flow rates. Too high a compression force results in cracking the cassette or cutting the filter, also producing leakage.

Prudence dictates that a check of cassette integrity and the seal area on each filter should be made after sampling to ensure that the cassette was properly assembled; otherwise, the sample may underestimate the actual exposure.

At least two approaches to eliminating the sealing problem with press-fitted cassettes have been taken. One was to assemble the cassette using a press. Pressing the cassette together by hand often produces misalignment of the cassette parts, resulting in bypass leakage. Frazee and Tironi [1987] designed a mechanical press that held the two cassette pieces in proper alignment, while applying just enough pressure to effect a seal, but not so much as to cause cracking of the plastic. This press was designed to allow motion of the cassette pieces to compress to a certain distance. A commercial pneumatic press (Accu-Press™, Omega Specialty, Chelmsford, MA) used a selected pressure to compress the cassette components. For additional information on bypass leakage and bypass leak test procedures see [Baron 2002]. The second approach was to redesign the cassette to provide a more positive filter seal [Van den Heever 1994]. In a well-designed sampler, opening the seal should not cause tearing and loss of the filter or collection medium during removal from the sampler.

The 37-mm closed-face cassette is usually sealed with tape or shrink bands around the outside. There is a common misconception that this seal prevents bypass leakage in the cassette. These external seals primarily cover the joint between the cassette components to prevent deposited particles on the external surface of the cassette from contaminating the sample during filter removal. The tape or shrink band also aids in holding the cassette together and preventing external air leakage. However, Puskar, et al. [1991] found that even by using this precaution, a significant amount of dust was found downstream of the filter. The authors hypothesized that this dust was deposited during filter removal.

Three other commercial samplers, the IOM (Figure 2B), the CIS, and the coal mine dust sampler (MSA, Inc., Pittsburgh, PA) use a cartridge to hold the filter. For the first two samplers, an external threaded cover applies pressure to the cartridge to ensure a good seal around the filter. This prevents twisting at the filter surface while creating positive, even contact around the filter edge.

5 Electrostatic losses

Most aerosol particles generated in workplaces have electrostatic charge levels considerably higher than the steady-state or equilibrium charge level [Johnston et al. 1985]. The



equilibrium charge (Boltzmann equilibrium) levels are usually achieved after particles are suspended in the ambient atmosphere for approximately an hour in the presence of naturally occurring atmospheric ions of positive and negative polarity. When freshly generated particles are sampled in the presence of an electric field, as when a sampler walls are highly charged [Baron and Deye 1990b], the particle trajectories can be modified to such an extent that the particles are inefficiently sampled. No electrostatically induced particle motion occurs when either the particle charge or electric field during sampling is zero. When both the sampler walls and particles are both highly charged, external force on the particles from electrical field is much greater than that caused by gravity, inertia, diffusion or other mechanisms.

Samplers can achieve a high charge level when they are electrically insulated from ground and are triboelectrically charged (i.e., by contacting or rubbing against other surfaces); this sampler charging, as well as particle charging, tends to occur more frequently at low (<20% RH) humidity levels. Certain plastic materials, such as polycarbonate, polytetrafluoroethylene, polyvinyl chloride (PVC), and polystyrene readily retain high charge levels; others, such as Tygon® or conductive silicone rubber tubing retain relatively little charge [Liu et al. 1985]. The PVC/polystyrene copolymer used in the 37-mm closed-face cassette is an excellent electrical insulator and can retain high charge levels on its surface. These charges can be incorporated in the bulk plastic during manufacture or accumulated on the surface by handling or contact with other objects; the charge levels and polarity are highly localized and variable. Such samplers can exhibit particle losses to the internal walls of the cassette and negative sampling biases [Baron and Deye 1990a]. Non-conductive plastic asbestos samplers were shown to produce large negative biases and variable results [Baron and Deye 1990a,b; Baron et al. 1994].

Conductive samplers have demonstrably lower losses when sampling charged particles. Metal samplers obviously have high conductivity. Samples collected using nylon cyclones were shown to exhibit higher variability [Almich and Carson 1974; Briant and Moss 1984] and negative biases [Briant and Moss 1984] when sampling charged dusts. However, the degree of conductivity required is not high; as long as charges can move over the sampler surface and reach equilibrium in seconds, the effect of charges transferred to the sampler is likely to be minimized. Materials with this low level conductivity (surface resistivity <108 ohms/square) are often termed “static-dissipative.” Graphite-loaded plastics were developed that have adequate conductivity to distribute charges over the surface of the cassette (e.g., the 25-mm asbestos sampler). A simple test to ensure adequate conductivity of these samplers can be performed by attaching a good quality multimeter at any two points on the sampler surface. Resistance readings in the range of tens of megohms or less indicate sufficient conductivity for sampling purposes.



Some metals are coated with a thin, non-conductive layer, e.g., anodized aluminum. These coatings may retain a surface charge, but this charge will induce an opposite charge in the conductive layer beneath the surface, effectively canceling out the field produced by the surface charge. Recent measurements at NIOSH using a non-contacting electrostatic voltmeter (Model 300, Trek Inc., Medina NY) indicated that no significant external field (<50 volts) could be produced near an anodized surface by rubbing the surface with various plastics or other materials. Plastic or cellulose-based materials rubbed in a similar manner produced electrostatic potentials measured in the hundreds to thousands of volts. Thus, metals with a thin, insulating surface layer are not likely to produce significant external fields that would affect aerosol sampling.

Digestible cassette inserts or capsules, consisting of a static-dissipative plastic dome directly sealed to a filter, have been developed for metals analysis that substantially reduce the error associated with wall losses [Ashley et al. 2013].

A further electrostatic problem not specifically associated with the cassette is the use of filters made of highly nonconductive materials, such as PVC, polytetrafluoroethylene, or polycarbonate. In addition to having desirable chemical properties, these filters have the advantage of not absorbing water from atmosphere, leading to improved weight stability [Lowrey and Tillery 1979; Bowman et al. 1984; NIOSH 1994]. However, these filters can retain a high electrostatic charge level, resulting in non-uniform particle deposition and even repulsion of particles from the filter surface. Such filters are also more difficult to handle during weighing because of charge effects. Even filters that are normally more conductive, such as cellulose-based filters, can become non-conductive and exhibit non-uniform particle deposition and particle losses at very low humidity levels (<10% RH) [Chen and Baron 1995].

A treatment was developed to make filters more conductive without significantly affecting weighing accuracy or moisture absorption [Mark 1974]. In one study, it was found that applying this treatment to the filter decreased particle losses from 14% to 2% [Blackford et al. 1985]. Anti-static sprays are available that leave a temporary static-dissipative coating on surfaces.

6 Sampler deposition uniformity

Some analytical methods require that sampled particles be deposited uniformly on the filter surface. For instance, asbestos fiber analysis by microscopy requires uniform deposition of fibers on the filter for accurate results. Direct silica analysis of collected filter samples also is improved with uniform particle deposition. Classifiers using inertial or gravitational forces tend to stratify the aerosol stream. A small, high velocity inlet in a sampler, such as the 4-mm opening in the 37-mm closed-face cassette, can also result in the larger particles being



deposited in a small central area on the filter. Even sampling at high flow rates through more open inlets can cause a non-uniform deposit [Feigley et al. 1992]. This results in particle deposits that vary in uniformity as a function of particle size. Such deposition patterns are visible when sampling colored particles [Sass-Kortsak et al. 1993]. Open-pore foam classifiers may improve the uniformity of particle deposits on the filter, but have not been thoroughly evaluated [Aitken et al. 1993; Vincent et al. 1993]. Careful design of classifiers to ensure mixing of the aerosol prior to deposit on the filter may result in adequate uniformity [Fang and Lippmann 1995]. Even inhalable samplers or samplers that have no classifier may be prone to non-uniform deposits under certain conditions of sampler orientation relative to gravitational settling, orientation relative to external winds, or when sampling charged particles [Baron and Deye 1990b; Liu et al. 1985; Baron et al. 1994; Chen and Baron 1995]. Flaring the inlet of such a sampler, as in the commercial “bell-mouth cowl,” (Figure 2F, Envirometrics, Charleston, SC), is one approach to improving sample uniformity under anisokinetic conditions [Feigley et al. 1992]. In another study, a sampler having an inlet screen (button sampler, Figure 2D, SKC, Inc. Eighty Four, PA) exhibited improved filter deposit uniformity when compared to a closed-face cassette [Hauck et al. 1996].

The filters in some samplers require support to prevent tearing or distortion of the filter. The support device may cause occlusion of parts of the filter surface, resulting in non-uniform particle deposits [Hook et al. 1983].

On occasion, it was observed that poorly-sized tubing connectors protruded into the 37-mm cassette and touched the filter surface. This caused all the airflow to pass through the filter adjacent to the small area of the connector opening. When undetected, this caused low sampling efficiency and pump failure because of the high pressure drop.

7 Sampler wall losses

Particle deposits on internal surfaces (i.e., wall losses) of the 37-mm closed-face cassette for several hundred field measurements were found to be large and highly variable (2 - 100% of dust collected in the cassette) [Demange et al. 1990]. Another study found only 22% of the dust on the filter, 65% on the upstream portion of the cassette, and 22% downstream of the filter [Puskar et al. 1991]. In a study of an in-line cassette of similar shape, it was found that the internal wall deposition of particles could be largely eliminated by: (a) making the cassette conductive, (b) creating an aerodynamically smooth surface having no corners for eddies to form, and (c) decreasing the diameter of the filtration area so that dust does not deposit on the filter adjacent to the upstream walls of the cassette [Blackford et al. 1985]. By incorporating these three corrective measures, the wall losses in the latter cassette were reduced from 25-30% to 5%. These losses appear to be caused by a combination of electrostatic, inertial, gravitational and diffusion mechanisms.



Another solution to the problem of not capturing 100% of the sampled particles on the filter is to use an internal capsule sealed to the filter. All the particles collected in the combined filter capsule are analyzed. The air stream entering the cassette is surrounded by the cartridge and any deposition on the walls of the capsule is retained for analysis. The IOM sampler for inhalable dust uses this approach by having a cartridge form the inlet of the sampler (Figure 2B). This approach also has been used in the in-line cassette of the coal mine dust personal sampling unit (MSA, Pittsburgh, PA) where an aluminum foil cover is crimped onto the filter. A similar cartridge was designed for the 37-mm closed-face cassette in measurements of pharmaceutical dust [Puskar et al. 1992]. Capsules made of “static dissipative” plastic for gravimetric analysis and capsules composed of cellulosic media for elemental analysis are commercially available (Accu-Cap™, Omega Specialty Instruments, Chelmsford, MA; Woodchek™, MSA Inc. Pittsburgh, PA). It is important that capsule material be compatible with the analytical method. For instance, the plastic material used in the first version of the IOM sampler cartridge (Figure 2B, SKC, Eighty Four, PA) was found to absorb milligrams of water over periods of days, making the accuracy of gravimetric measurements problematic [Smith et al. 1997; Li and Lundgren 1999; Lidén and Bergman 2001]. Demange et al. [2002] more recently demonstrated significantly improved agreement between inhalable sampling using the IOM sampler and the 37-mm cassette by including all deposits inside the cassette. This suggests that the accuracy and precision of the 37-mm cassette can be improved by including internal sampler deposits by wiping or washing, or by using an internal capsules [Ashley and Harper 2013; Harper and Ashley 2013; Andrews et al. 2016].

8 Collection media and analytical issues

Interaction of particulate filter with the sampled aerosol and the flow can lead to certain measurement errors, which are sometimes referred to as filter artifacts. These artifacts can include adsorption of gases and vapors from the air stream, the adsorption or desorption of moisture by the filter media, evaporation of volatile or semi-volatile organic matter from the filter media, and particle bounce from the filter media. All these factors can contribute to the measurement bias.

The filter medium should be compatible with the analytical method. Some analytical methods require specific filter media or properties. For instance, atomic absorption and inductively coupled plasma analyses typically require complete ashing of the filter material; organic compound analyses require that no reaction or adsorption of the compounds occur at the filter surface. Several studies have dealt with gravimetric stability of different filter types and recommended specific procedures [Lowrey and Tillery 1979; Bowman et al. 1984; NIOSH 1994; ASTM 2000; Chow 1995; Raynor et al. 2011]. Generally, plastic materials that do not absorb water (polycarbonate, polyvinyl chloride, polytetrafluoroethylene) are more weight



stable than natural cellulose-based materials; uncoated glass fiber filters also may absorb water [Lowrey and Tillery 1979; Bowman et al. 1984; NIOSH 1994; ASTM 2000; Chow 1995].

Controlled environmental conditions in the weighing room, where temperature and humidity are strictly controlled, are essential to reduce measurement bias in gravimetric analysis. In a controlled study Tsai et al. [2012] have shown that the mass of MCE membrane filters was less stable than that of the glass fiber filters in both controlled and uncontrolled environmental conditions. Also, they found that under uncontrolled conditions (where humidity and temperatures were not controlled), glass fiber filter mass was much less stable than that of PTFE and PVC membrane filters. MCE and glass fiber filters demonstrated significantly better stability under controlled conditions; whereas the PVC and especially the PTFE filters were found to be extremely stable in both controlled and uncontrolled conditions [Raynor et al., 2011]. Other non-aqueous vapors can also adsorb to the filter media or previously collected particulate deposits. However, these artifacts are typically important only for semi-volatile organic compounds.

It should be noted that weight stable materials also tend to be more highly charged, resulting in more charged particle repulsion and deposit non-uniformity. When a plastic (Tyvek®) backup pad is crimped into a cartridge together with a filter, the weight stability of the cartridge may suffer [Kogut et al. 1999]. To improve the weight stability of coal mine dust sampler cartridges, stainless steel backup pads have been used by MSHA. The IOM sampler can be purchased with either a plastic or a stainless steel cartridge. The plastic cartridge has been shown to exhibit poor weight stability and should not be used for gravimetric analysis [Smith et al. 1997; Lidén and Bergmann 2001].

Lawless and Rodes investigated the use of modern electronic balances to determine factors affecting the accuracy of gravimetric measurements and found that balance stability, balance leveling, vibration and thermal drafts, electrostatic charge reduction, positioning of the filter in the balance so that the filter did not hang over the edge of the pan, and temperature and humidity control were all important in achieving accurate results [Lawless and Rodes 2001].

Although not strictly a problem with the collection medium, the sampler construction material should not outgas vapors that can condense on the collection medium and affect the analysis. Early (circa 1970) versions of the closed-face cassette were made of a plastic called “tenite,” which resulted in weight gain of the filter over time. This currently does not appear to be a problem.

Impactors have been used as samplers and, especially with cascade impactors, the deposits on the impaction stages are measured. Particle bounce from the collection substrates on the impaction plates can be severe, especially for large solid particles impacting onto a smooth



metal plate [Marple and Olsen 2011]. Bounce can also be significant for highly nonspherical, low density particles, as was shown recently for nanotubes agglomerates [Birch et al. 2011; Maynard et al. 2004; Baron et al. 2008]. Several modifications to the collection substrate are available to improve collection efficiency of each stage. These modifications should be compatible with the analytical method. Oil can be placed on the collection substrate that wicks up over collected particles and continually provides an oiled surface. To avoid the interference or contamination of particles by oil, the following scheme has been used in recent studies: a pair of cascade impactors was prepared for sampling at a given location. Oiled filters were used on every other stage of each impactor. One of the impactors was loaded with oiled filters on Stages A and C, while Stages B and D were uncoated and used to sample particles onto the substrates. The second impactor contained oiled filters on Stages B and D, while Stages A and C were used for particle sampling. This approach provided data for all four stages (plus after filter) and minimized bounce to the adjacent lower stage [Baron et al. 2008; Birch et al. 2011]. A filter or sintered metal can be used to provide a reservoir for this oil. For gravimetric analysis, this oil must have a low vapor pressure and not migrate off the collection substrate. Alternatively, grease can be used, but after the surface is coated with collected particles, additional particles are more likely to bounce. Filters have also been used as substrates and provide a convenient substrate that is somewhat better than a smooth metal surface. Selection and use of an impactor is a complex issue and has been described in reviews [Lodge and Chan 1986; Marple et al. 2001]. Accurate analysis of cascade impactor data can also be difficult and simple regression analysis of the data may not provide the best answer [Marple et al. 2001; Kandlikar and Ramachandran 1999; Cooper 2001].

9 Sampler field comparisons

Direct field comparisons of various samplers are frequently reported in the literature. Because of the typical high variability of aerosol concentrations and size distributions in workplaces, it is difficult to use these situations for accurate assessment of sampler performance. However, field studies are important to verify the overall performance of a sampler and to indicate specific sampler issues. The problems with samplers as discussed above can be highlighted with some examples observed in field studies.

a. Sampler bias affected by internal deposits

A study of wood dust sampling comparing collocated free-standing samplers indicated that an MSA cassette (having an aluminum cartridge crimped onto the filter) used as a sampler gave two times better precision and collected 2.6 to 3.5 times more dust than the standard 37-mm closed-face cassette [NACSI 1992]. Both these samplers have the same size and shape of inlet. The same study showed that the IOM sampler collected 1.3 times more dust than the MSA cassette, indicating that the particle size, inlet shape and inlet orientation are important factors in inhalable sampling. Among a number of inhalable

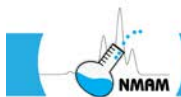

samplers in current use around the world, the IOM sampler appears to agree the best with the inhalable dust sampling convention [Kenny et al. 1997; Bartley 1998]. Several studies have shown that the IOM sampler collects anywhere from slightly more to 3.5 times more dust than the closed-face cassette [Vaughan et al. 1990; Burdorf et al. 1994; Notø et al. 1996; Perrault et al. 1996; Wilsey et al. 1996]. However, Demange et al. showed that for several work sites with relatively small MMAD (about 15 μm diameter), measurements from 37-mm cassettes agreed well with the IOM results if the deposits on the internal surfaces of the cassette were added to the filter analyte [Demange et al. 2002; Harper and Demange 2007]. Measurements with the 37-mm cassette are not expected to agree as well with the IOM when the particle sizes are much larger because of differences in aspiration efficiency. However, by including all aspirated material, i.e., all material entering the 37-mm cassette inlet, in the analysis, agreement with the inhalable convention can be improved.

b. Sampler precision affected by internal deposits

The issue of measurement bias from internal wall deposits in the sampler has gained increasing recognition over the past few decades [Ashley and Harper 2013]. Though it is now widely recognized that the wall deposits must be included in the analysis, many published methods have not been modified. OSHA currently recommends including wall deposits.

In a field study of lead dust, it was found that the measurements from a closed-face 37-mm cassette gave a coefficient of variation (CV) of 1.0 and 0.33 when sampling at 2 L/min and 10 L/min, respectively, while the button sampler gave a CV of 0.10 under the same conditions [Hauck et al. 1996]. The button sampler has few internal surfaces for wall deposition, suggesting that elimination of this type of loss would improve the precision of the 37-mm cassette. Demange et al. [2002] found improved precision for the 37-mm cassette data when the wall deposits were added to the analyte.

In spite of some of its drawbacks, the 37-mm cassette is likely to be used for some time. It appears that from the standpoint of improving agreement with the inhalable convention and improving precision, the inhalable sampler wall losses should be minimized through sampler design (or through use of a cartridge such as the AccuCap or in the MSA coal mine cassette) or the wall deposits should be included in the analysis.

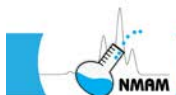

10 Conclusions

Clearly, when proper features are incorporated in the sampler design, significant improvements in bias and precision can be achieved for some currently used aerosol samplers. Several recommendations regarding the application of these samplers are listed:

- Classifiers used to select respirable, thoracic, or other fractions should be evaluated based on bias maps obtained from experimental data and combined with particle size distributions from workplace measurements to evaluate their applicability.
- Further research and development is needed to improve sampler design to better match ACGIH/ISO conventions and reduce inter-laboratory variability in conducting aerosol sampling. It is important to report the sampler and flow rate used to allow evaluation of potential biases due to sampling. It is also important to account for wall losses to reduce overall bias and allow better comparison across different samplers and ISO standards.
- The filter cassette and fittings should be air-tight and have no bypass leakage. A pneumatic or mechanical press should be used to assemble the cassette and a leak test should be used to establish appropriate pressure and proper assembly procedures. See [Baron 2002].
- The sampler should be made of conductive or static-dissipative materials.
- Internal deposits in sampling cassettes should be included in the analysis. One approach to improving the closed-face cassette measurements is to use an internal digestible cassette insert or cartridge that collects all the sampled dust entering the cassette. The cartridge must be compatible with the analytical method. Another approach is to wipe or wash the internal surfaces of the cassette and add this material to the filter analyte.

Disclaimer

Mention of any company or product does not constitute endorsement by NIOSH. In addition, citations to websites external to NIOSH do not constitute NIOSH endorsement of the sponsoring organizations or their programs or products. Furthermore, NIOSH is not responsible for the content of these websites. All web addresses referenced in this document were accessible as of the publication date.

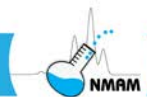

11 References

- ACGIH [2015]. Appendix C: Particle size-selective sampling criteria for airborne particulate matter. In: 2015 TLVs® and BEIs®. Cincinnati, OH: American Conference of Governmental Industrial Hygienists.
- Aitken RJ, Vincent JH, Mark D [1993]. Application of porous foams as size selectors for biologically relevant samplers. *Appl Occup Environ Hyg* 8:363-369.
- Aitken RJ, Baldwin PEJ, Beaumont GC, Kenny LC, Maynard AD [1999]. Aerosol inhalability in low air movement environments. *J Aerosol Sci* 30:613-626.
- Aizenberg V, Choo K, Grinshpun S, Willeke K, Baron P [2001]. Evaluation of personal aerosol samplers challenged with large particles. *J Aerosol Sci* 32:779-793.
- Almich BP, Carson GA [1974]. Some effects of charging on 10-mm nylon cyclone performance. *Am Ind Hyg Assoc J* 34:603-612.
- Andrews RN, Feng HA, Ashley K [2016]. Interlaboratory evaluation of cellulosic acid-soluble internal air sampling capsules for multi-element analysis. *J Occup Environ Hyg* 13:40-47, <http://dx.doi.org/10.1080/15459624.2015.1072635>.
- Ashley K, Harper M [2013]. Closed-face filter cassette (CFC) sampling—Guidance on procedures for inclusion of material adhering to internal sampler surfaces. *J Occup Environ Hyg* 10(3):D29-D33.
- ASTM [2011]. Standard practice for controlling and characterizing errors in weighing collected aerosols D6552-06(2011). West Conshohocken, PA: ASTM International.
- Baldwin PEJ and Maynard AD [1998]. A survey of windspeeds in indoor workplaces. *Ann Occup Hyg* 20:303-313.
- Baron PA [1983]. Sampler evaluation with an aerodynamic particle sizer. In: Marple VA, Liu BYH, eds. *Aerosols in the mining and industrial work environment*. Vol. 3 Instrumentation. Minneapolis, MN: Ann Arbor Press, pp. 861-877.
- Baron PA [1996]. Application of the thoracic sampling definition to fiber measurement. *Am Ind Hyg Assoc J* 57:820-824.



Baron PA [1998]. Personal aerosol sampler design: A review. *Appl Occup Environ Hyg* 13:313-320.

Baron PA [2002]. Using a filter bypass leakage test for aerosol sampling cassettes. *Appl Occup Environ Hyg* 17(9):593-597.

Baron PA, Deye GJ [1990a]. Electrostatic effects in asbestos sampling I: experimental measurements. *Am Ind Hyg Assoc J* 51:51-62.

Baron PA, Deye GJ [1990b]. Electrostatic effects in asbestos sampling II: comparison of theory and experiment. *Am Ind Hyg Assoc J* 51:63-69.

Baron PA, John W [1999]. Sampling for thoracic aerosol. In: Vincent JH, ed. Particle size-selective sampling for particulate air contaminants. Cincinnati, OH: American Conference of Governmental Industrial Hygienists, pp. 141-154.

Baron PA, Chen CC, Hemenway DR, O'Shaughnessy P [1994]. Non-uniform air flow in inlets: the effect on filter deposits in the fiber sampling cassette. *Am Ind Hyg Assoc J* 55:722-732.

Baron PA, Deye GJ, Chen BT, Schwegler-Berry DE, Shvedova AA, Castranova V [2008]. Aerosolization of single-walled carbon nanotubes for an inhalation study. *Inhal Toxicol* 20:751-760.

Bartley DL, Chen C-C, Song R, Fischbach TJ [1994]. Respirable aerosol sampler performance testing. *Am Ind Hyg Assoc J* 55:1036-1046.

Bartley DL [1998]. Inhalable aerosol samplers. *Appl Occup Environ Hyg* 13:274-278.

Berry RD, Froude S [1989]. An investigation of wind conditions in the workplace to assess their effect on the quantity of dust inhaled, Internal Report IR/L/DS/89/3. Health and Safety Executive, London.

Birch ME, Ku BK, Evans DE, Ruda-Eberenz TA [2011]. Exposure and emissions monitoring during carbon nanofiber production-part I: Elemental carbon and iron-soot aerosols. *Ann Occup Hyg* 55:1016-1036.

Blackford DB, Harris GW, Revell G [1985]. The reduction of dust losses within the cassette of the SIMPEDS personal dust sampler. *Ann Occup Hyg* 29:169-180.



Briant JK, Moss OR [1984]. The influence of electrostatic charges on the performance of 10-mm nylon cyclones. *Am Ind Hyg Assoc J* 45:440-445.

Brown RC [1980]. Porous foam size selectors for respirable dust samplers. *J Aerosol Sci* 11:151-159.

Buckley TJ, Waldman JM, Freeman NCG, Lioy PJ, Marple VA, Turner WA [1991]. Calibration, intersampler comparison and field application of a new PM-10 personal air-sampling impactor. *Aerosol Sci Technol* 14:380-387.

Burdorf A, Lillienberg L, Brisman J [1994]. Characterization of exposure to inhalable flour dust in Swedish bakeries. *Ann Occup Hyg* 38:67-78.

Caplan KJ, Doemeny LJ, Sorenson SD [1977]. Performance characteristics of the 10 mm cyclone respirable mass sampler: part I-monodisperse studies. *Am Ind Hyg Assoc J* 38:83-96.

Cecala AB, Volkwein J, Timko RJ, Williams KL [1983]. U.S. Bureau of Mines Report of Investigations RI-8764: Velocity and orientation effects on the 10-mm nylon Dorr-Oliver cyclone. Avondale, MD: U.S. Department of the Interior, Bureau of Mines.

CEN [1993]. Workplace atmospheres – size fraction definitions for measurement of airborne particles. CEN EN481:1993. Brussels, Belgium: European Standardization Committee.

CEN [1997]. Workplace atmospheres--assessment of performance of instruments for measurement of airborne particle concentrations. Draft European Standard CEN/TC137 N 164. Brussels, Belgium: European Standardization Committee.

CEN [1998], Workplace atmospheres - assessment of performance of instruments for measurement of airborne particle concentrations, European Standard EN 13205, Brussels, Belgium: European Standardization Committee.

Cena LG, Anthony TR, Peters TM [2011]. A personal nanoparticle respiratory deposition (NRD) sampler. *Environ Sci Technol* 45(15):6483-6490.

Chen C-C, Baron PA [1995]. Vortices in anisoaxial sampling inlets. *Aerosol Sci Technol* 23:224-230.

Chen C-C, Baron PA [1996]. Aspiration efficiency and wall deposition in the fiber sampling cassette. *Am Ind Hyg Assoc J* 52:142-152.



Chen C-C, Huang S-H, Lin W-Y, Shih T-S, Jeng F-T [1999a]. The virtual cyclone as a personal respirable sampler. *Aerosol Sci Technol* 31:422-432.

Chen C-C, Lai C-Y, Sheng T-S, Hwang J-S [1999b]. Laboratory performance comparison of respirable samplers. *Am Ind Hyg Assoc J* 60:601-611.

Chow JC [1995]. Measurement methods to determine compliance with ambient air quality standards for suspended particles. *J Air Waste Manage Assoc* 45:320-382.

Cooper DW [2001]. Methods of size distribution data analysis and presentation. In: Baron P, Willeke K, eds. *Aerosol measurement: principles, techniques and applications*. New York, NY: John Wiley & Sons, pp. 667-701.

Courbon P, Wrobel R, Fabriès J-F [1988]. A new individual respirable dust sampler: The CIP 10. *Ann Occup Hyg* 32:129-143.

Demange M, Gendre JC, Herve-Bazin B, Carton B, Peltier A [1990]. Aerosol evaluation difficulties due to particle deposition on filter holder inner walls. *Ann Occup Hyg* 34:399-403.

Demange M, Görner P, Elcabache J-M, Wrobel R [2002]. Field comparison of 37-mm closed-face cassettes and IOM samplers. *Appl Occup Environ Hyg* 17:200-208.

Esmen NA, Erdal S [1991]. The size of fibrous aerosols. *Appl Occup Environ Hyg* 6:764-772.

Fabriès JF, Gorner P, Wrobel R [1989]. A new air sampling instrument for the assessment of the thoracic fraction of an aerosol. *J Aerosol Sci* 20:1589-1592.

Fairchild CI, Tillery MI, Smith JP, Valdez FO [1980]. Collection efficiency of field sampling cassettes: Interagency Energy/Environment R & D Program Report. LA-8640-MS. Los Alamos NM: Los Alamos National Laboratory.

Fang CP, Lippmann M [1995]. Development of thoracic inlets for asbestos fiber sampling. Unpublished paper presented at American Industrial Hygiene Conference and Exposition, Kansas City, MO, May 20-26.

Feigley CE, Maguire KE, Hussey JR [1992]. Asbestos fiber deposition patterns on various 25-mm cassette filters at a high flow rate. *Appl Occup Environ Hyg* 7:749-757.



- Frazer PR, Tironi G [1987]. A filter cassette assembly method for preventing bypass leakage. *Am Ind Hyg Assoc J* 48:176-180.
- Görner P, Fabriès JF, Wrobel R [1994]. Thoracic fraction measurement of cotton dust. *J Aerosol Sci* 25:S487-S488.
- Görner P, Wrobel R, Micka V, Skoda V, Denis J, Fabriès J-F [2001]. Study of fifteen respirable aerosol samplers used in occupational hygiene. *Ann Occup Hyg* 45:43-54.
- Grinshpun S, Willeke K, Kalatoor S [1993]. A general equation for aerosol aspiration by thin-walled sampling probes in calm and moving air. *Atmos Environ* 27A:1459-1470.
- Gudmundsson A, Lidén G [1998]. Determination of cyclone model variability using a time-of-flight instrument. *Aerosol Sci Technol* 28:197-214.
- Hauck BC, Grinshpun SA, Reponen A, Reponen T, Willeke K, Bornschein RL [1996]. Field testing of new aerosol sampling method with a porous curved surface as inlet. *Am Ind Hyg Assoc J* 58:713-719.
- Harper M, Ashley K [2013]. Acid-soluble internal capsules for closed-face cassette elemental sampling and analysis in workplace air. *J Occup Environ Hyg* 10:297-306.
- Harper M, Demange M [2007]. Concerning sampler wall desposits in the chemical analysis of airborne metals. *J Occup Environ Hyg* 4(9):D81-D86.
- Hook MB, Feigley CE, Ludwig DA [1983]. Interwedge variation in the membrane filter method for airborne asbestos fibers. *Am Ind Hyg Assoc J* 44:542-546.
- ISO [1995]. Air quality–particle size fraction definitions for health-related sampling. ISO 7708:1995(en). Geneva: International Organization Standardization.
- John W [1994]. Universal impactor for particle collection within sampling criteria. Abstracts 13th Annual AAAR Conference (Los Angeles), p. 929. Los Angeles, CA: American Association for Aerosol Research.
- Johnston AM, Vincent JH, Jones AD [1985]. Measurements of electric charge for workplace aerosols. *Ann Occup Hyg* 29:271-284.



Jones AD, Aitken RJ, Armbruster L, Byrne P, Fabriès J-F, Kauffer E, Lidén G, Lumens M, Maynard A, Riediger G, Sahle W [2001]. Thoracic sampling of fibres. 349/2001, Sheffield, UK, Health and Safety Executive.

Kandlikar M, Ramachandran G [1999]. Inverse methods for analysing aerosol spectrometer measurements: a critical review. *J Aerosol Sci* 30:413-437.

Kennedy NJ, Hinds WC [2002]. Inhalability of large solid particles. *J Aerosol Sci* 33:237- 256.

Kenny LC [1995]. Pilot study of CEN protocols for the performance testing of workplace aerosol sampling instruments. EU project MAT1-CT92-0047, Sheffield, UK: Health and Safety Laboratory.

Kenny LC, Gussman RA [1997]. Characterization and modelling of a family of cyclone aerosol pre-separators. *J Aerosol Sci* 28:677-688.

Kenny LC, Aitken R, Chalmers C, Fabriès JF, Gonzalez-Fernandez E, Kromhout H, Lidén G, Mark D, Riediger G, Prodi V [1997]. A collaborative European study of personal inhalable aerosol sampler performance. *Ann Occup Hyg* 41:135-153.

Kimura K [1978]. On the t-r (total and respirable) dust sampler. *J Sci Labour (Japan)* 54: 9-17.

Koehler KA, Anthony TR, Van Dyke M, Volckens J [2012]. Solid versus liquid particle sampling efficiency of three personal aerosol samplers when facing the wind. *Ann Occup Hyg* 56(2):194-206.

Koehler KA, Volckens J [2013]. Development of a sampler to estimate regional deposition of aerosol in the human respiratory tract. *Ann Occup Hyg* 57(9):1138-1147.

Kogut J, Tomb TF, Gareis MB, Parobeck PS, Gero AJ [1999]. MSHA Internal Report: Variability in weight gain of unexposed filter capsules within batches of filter capsules used in MSHA's respirable coal mine dust enforcement program. Pittsburgh, PA: Mine Safety and Health Administration.

Ku BK, Kulkarni P [2015]. Measurement of transport properties of aerosolized nanomaterials. *J Aerosol Sci* 90:169-181.



Kulkarni P, Baron PA, Sorensen CM, Harper M [2011]. Nonspherical particle measurement: Shape factor, fractals, and fibers. In: Kulkarni P, Baron PA, Willeke K, eds. *Aerosol measurement: principles, techniques, and applications*. 3rd ed. New York: John Wiley & Sons, Inc., pp. 509-547.

Lawless PA, Rodes CE [2001]. Maximizing data quality in the gravimetric analysis of personal exposure sample filters. *J Air Waste Manage Assoc* 49:1039-1049.

Li S-N, Lundgren DA [1999]. Weighing accuracy of samples collected by IOM and CIS inhalable samplers. *Am Ind Hyg Assoc J* 60:235-236.

Lidén G [1994]. Performance parameters for assessing the acceptability of aerosol sampling equipment. *Analyst* 119:27-33.

Lidén G [2000a]. Presentation of the results from round 1 of ASTEX. *J Aerosol Sci* 31: S270-S271.

Lidén G, Bergman G [2001]. Weighing imprecision and handleability of the sampling cassettes of the IOM sampler for inhalable dust. *Ann Occup Hyg* 45:241-252.

Lidén G, Gudmundsson A [1996]. Optimization of a cyclone to the 1993 international sampling convention for respirable dust. *Appl Occup Environ Hyg* 11:1398-1408.

Lidén G, Juringe L, Gudmundsson A [2000b]. Workplace validation of a laboratory evaluation test of samplers for inhalable and "total" dust. *J Aerosol Sci* 31:191-219.

Lippmann M, Gearhart JM, Schlesinger RB [1987]. Basis for a particle size-selective TLV for sulfuric acid aerosols. *Appl Ind Hyg* 2:188-199.

Liu BYH, Pui DYH, Rubow KL, Szymanski WW [1985]. Electrostatic effects in aerosol sampling and filtration. *Ann Occup Hyg* 29:251-269.

Lodge JP, Chan TL, eds. [1986]. *Cascade impactor sampling and data analysis*. Akron OH: American Industrial Hygiene Association.

Lowrey L, Tillery M [1979]. Filter weight stability evaluation. LA-8061-MS. Los Alamos, NM: Los Alamos National Laboratory.



Lynch JR [1970]. Evaluation of size-selective presamplers: I. Theoretical cyclone and elutriator relationships. *Am Ind Hyg Assoc J* 31:548-551.

Mark D [1974]. Problems associated with the use of membrane filters for dust sampling when compositional analysis is required. *Ann Occup Hyg* 17:35-40.

Mark D, Borzucki G, Lynch G, Vincent JH [1988]. The development of a personal sampler for inspirable, thoracic and respirable aerosol. Unpublished paper presented at Annual Conference of the Aerosol Society, Bournemouth, UK, March 22-24.

Marple VA [1978]. Simulation of respirable penetration characteristics by inertial impaction. *J Aerosol Sci* 9:125-134.

Marple VA, Olson B [2011]. Sampling and measurement using inertial, gravitational, centrifugal, and thermal techniques. In: Kulkarni P, Baron P, Willeke K, eds. *Aerosol measurement: principles, techniques and applications*. 3rd ed. New York: John Wiley & Sons, Inc., pp. 129-151.

Maynard AD [1996]. Sampling errors associated with sampling plate-like particles using the Higgins- and Dewell-type personal respirable cyclone. *J Aerosol Sci* 27:575-586.

Maynard AD [1999]. Measurement of aerosol penetration through six personal thoracic samplers under calm air conditions. *J Aerosol Sci* 30:1227-1242.

Maynard AD, Baron PA, Foley M, Shvedova AA, Kisin ER, Castranova V [2004]. Exposure to carbon nanotube material: Aerosol release during the handling of unrefined single-walled carbon nanotube material. *J Toxicol Environ Health, Part A* 67:87-107.

NCASI [1992]. Comparison of personal sampling devices for the estimation of wood dust exposure levels. Special Report No. 92-09. Cary, NC: National Council for Air and Stream Improvement.

NIOSH [1984]. Accuracy criteria recommended for the certification of gravimetric coal mine dust samplers. By Bowman JD, Bartley DL, Breuer GM, Doemeny LJ, Murdock DJ. Cincinnati, OH: U.S. Department of Health and Human Services, Centers for Disease Control, National Institute for Occupational Safety and Health. Available from www.ntis.gov as accession no. PB 85-222446.

NIOSH [1994]. Particulates not otherwise regulated: Method 0500. In: Eller PM, Cassinelli ME, eds. *NIOSH manual of analytical methods*. 4th ed. Cincinnati, OH: U.S. Department of



Health and Human Services, Centers for Disease Control and Prevention, National Institute for Occupational Safety and Health, DHHS (NIOSH) Publication No. 94-113. [www.cdc.gov/niosh/nmam/].

NIOSH [1995]. Guidelines for air sampling and analytical method development and evaluation. By Kennedy ER, Fischbach TJ, Song R, Eller PM, Shulman SA. Cincinnati, OH: U.S. Department of Health and Human Services, Centers for Disease Control and Prevention, National Institute for Occupational Safety and Health, DHHS (NIOSH) Publication No. 95-117.

NIOSH [1998]. Criteria for a recommended standard: occupational exposure to metalworking fluids. Cincinnati, OH: U.S. Department of Health and Human Services, Centers for Disease Control and Prevention, National Institute for Occupational Safety and Health, DHHS (NIOSH) Publication No. 98-102.

Notø H, Halgard K, Daae HL, Bentsen RK, Eduard W [1996]. Comparative study of an inhalable and a total dust sampler for personal sampling of dust and polycyclic aromatic hydrocarbons in the gas and particulate phase. *The Analyst* 121:1191-1196.

Perrault G, Drolet D, Cloutier Y [1996]. Comparison of total and inhalable samplings of wood dust. Unpublished paper presented at American Industrial Hygiene Conference and Exposition, Washington, D.C., May 18-24.

Puskar MA, Harkins JM, Moomey JD, Hecker LH [1991]. Internal wall losses of pharmaceutical dusts during closed-face, 37-mm polystyrene cassette sampling. *Am Ind Hyg Assoc J* 52:280-286.

Puskar MA, Fergon SM, Harkins JM, Hecker LH [1992]. Gravimetric determination of airborne dust by using a filter cartridge inside a closed-face, 37-mm polystyrene cassette. *Am Ind Hyg Assoc J* 53:692-698.

Qi C, Echt A, Gressel MG [2016]. On the characterization of the generation rate and size-dependent crystalline silica content of the dust from cutting fiber cement siding. *Ann Occup Hyg* 60(2):220-230, <http://dx.doi.org/10.1093/annhyg/mev066>.

Ramachandran G, Sreenath A, Vincent JH [1998]. Towards a new method for experimental determination of aerosol sampler aspiration efficiency in small wind tunnels. *J Aerosol Sci* 29:875-891.



Raynor PC, Leith D, Lee KW, Mukund R [2011]. Sampling and analysis using filters. In: Kulkarni P, Baron PA, Willeke K, eds. *Aerosol measurements: principles, applications, and techniques*. 3rd ed. New York: John Wiley and Sons, Inc., pp.107-128.

Robert KQ [1979]. Cotton dust sampling efficiency of the vertical elutriator. *Am Ind Hyg Assoc J* 40:535-542.

Rodes CE, Kamens RM, Wiener RW [1995]. An experimental design to study the dispersal of contaminants released in close proximity to the body. *Am Ind Hyg Assoc J* 56:535-545.

Sass-Kortsak AM, O'Brien CR, Bozek PR, Purdham JT [1993]. Comparison of the 10-mm nylon cyclone, horizontal elutriator, and aluminum cyclone for silica and wood dust measurements. *Appl Occup Environ Hyg* 8:31-37.

Smith JP, Bartley DL, Kennedy ER [1997]. Laboratory investigation of the mass stability of sampling cassettes from inhalable aerosol samples. *Am Ind Hyg Assoc J* 59:582-585.

Tsai CJ, Liu CN, Hung SM, Chen SC, Uang SN, Cheng YS, Zhou Y [2012]. Novel active personal nanoparticle sampler for the exposure assessment of nanoparticles in workplaces. *Environ Sci Technol* 46(8):4546-4552.

Van den Heever DJ [1994]. Quantification of bypass leakage in two different filter cassettes during welding fume sampling. *Am Ind Hyg Assoc J* 55:966-969.

Vaughan NP, Chalmers CP, Botham RA [1990]. Field comparison of personal samplers for inhalable dust. *Ann Occup Hyg* 34:553-573.

Vincent JH [2007]. *Aerosol sampling: science, standards, instrumentation, and applications*. New York: John Wiley & Sons, Inc.

Vincent JH [1999a]. Sampling criteria for the inhalable fraction. In: Vincent JH, ed. *Particle size-selective sampling for particulate air contaminants*. Cincinnati OH: American Conference of Governmental Industrial Hygienists. pp. 51-72.

Vincent JH, ed. [1999b]. *Particle size-selective sampling for particulate air contaminants*. Cincinnati, OH: American Conference of Governmental Industrial Hygienists.

Vincent JH, Aitken RJ, Mark D [1993]. Porous plastic foam filtration media: penetration characteristics and applications in particle size-selective sampling. *J Aerosol Sci* 24:929-944.



Wilsey PW, Vincent JH, Bishop MJ, Brosseau LM, Greaves IA [1996]. Exposures to inhalable and "total" oil mist aerosol by metal machining shop workers. *Am Ind Hyg Assoc J* 57:1149-1153.

Witschger O, Willeke K, Grinshpun SA, Aizenberg V, Smith J, Baron PA [1997]. Simplified method for testing personal aerosol samplers. *J Aerosol Sci* 29:855-874.



NIOSH Manual of Analytical Methods (NMAM), 5th Edition

Sampling and Characterization of Bioaerosols

by William G. Lindsley, Brett J. Green, Francoise M. Blachere, Stephen B. Martin, Brandon F. Law, Paul A. Jensen and Millie P. Schafer, NIOSH

| | | |
|----|---|--------|
| 1 | Introduction | BA-2 |
| 2 | Principles of bioaerosol collection | BA-5 |
| 3 | Devices used for bioaerosol sampling | BA-10 |
| 4 | Considerations for bioaerosol sampling | BA-28 |
| 5 | Selection of bioaerosol samplers | BA-36 |
| 6 | Sample preparation for culturable bioaerosols | BA-39 |
| 7 | Identification of culturable bioaerosols | BA-42 |
| 8 | Enumeration of culturable bioaerosols | BA-46 |
| 9 | Sample analysis methods for non-viable and non-culturable bioaerosols | BA-49 |
| 10 | Limitations of bioaerosol sampling and characterization | BA-62 |
| 11 | Safety considerations | BA-65 |
| 12 | Resources | BA-65 |
| 13 | References | BA-66 |
| 14 | Appendix 1- List of manufacturers/distributors of common bioaerosol samplers and related products | BA-101 |
| 15 | Appendix 2 - Commonly used bioaerosol samplers | BA-104 |



Centers for Disease Control
and Prevention
National Institute for Occupational
Safety and Health

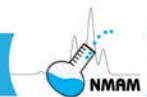

1 Introduction

Bioaerosols are airborne particles that originate from biological sources including animals, plants, fungi, bacteria, protozoa, and viruses. Examples of bioaerosols encountered in occupational environments include plant pollen, algae, fungal spores, bacteria such as actinomycetes, droplets produced during coughing and sneezing that may contain bacteria and viruses, dust containing insect excreta, animal dander, and fragments derived from each of these sources. Bioaerosols are ubiquitous and can be isolated from indoor, outdoor, and occupational environments using a variety of methods that either enumerate viable or a collection of viable and non-viable bioaerosols. Photomicrographs of example viral, bacterial, fungal, and plant bioaerosols are presented in Figure 1.

Bioaerosol monitoring is a rapidly emerging area of industrial hygiene due to the improved analysis methods such as polymerase chain reaction (PCR) and the impact that occupational exposures may have on worker respiratory health, particularly in microbial contaminated environments [Eduard et al. 2012; Environment Agency 2009; Haig et al. 2016; Hung et al. 2005; Macher 1999; Morey 2007; Nazaroff 2016]. Some human diseases encountered in healthcare settings such as measles and tuberculosis can be spread by bioaerosols containing infectious microorganisms [Ijaz et al. 2016; Jones and Brosseau 2015]. Soil saprophytic fungi such as *Coccidioides immitis* can be aerosolized during occupational disturbance activities and, if inhaled, can result in an acute pulmonary infection [Das et al. 2012; Wilken et al. 2014; Wilken et al. 2015]. The measurement of these bioaerosols in industrial hygiene includes the measurement of viable (culturable and non-culturable) and nonviable bioaerosols in indoor settings (e.g., industrial, office, education, and residential buildings), industrial facilities (e.g., biotechnology, composting, waste disposal, manufacturing, textile, and food processing), and outdoor environments (e.g., farms, feed lots, and general air quality). Monitoring for bioaerosols in the occupational environment is one of the many tools the industrial hygienist uses in the assessment of indoor air quality, infectious disease outbreaks, agricultural exposures, and industrial health.

Bioaerosol monitoring may be appropriate during workplace health and exposure assessments, epidemiological investigations, research studies, or in situations deemed appropriate by an occupational physician or immunologist. Sampling can also be used to evaluate occupational environments before and after mitigation of microbial contaminants. When investigating bioaerosols as a possible source of workplace exposures and health issues, bioaerosol sampling should be part of an integrated assessment of work conditions. This should also include examining heating, ventilation and air conditioning (HVAC) systems; checking for water infiltration and moisture control; evaluating microbial contamination in evaporative cooling systems, metal working fluids, and waste water; evaluating possible



internal and external sources of bioaerosols; and other measures [Macher 1999]. In general, if visible growth or contamination (microbial growth on floors, walls, or ceilings, or in the HVAC system) is observed, this normally should be mitigated first before indoor bioaerosol sampling is conducted. If personnel remain symptomatic after remediation, air sampling may be appropriate, but the industrial hygienist should be aware that false negative results are possible and should be interpreted with caution.

The industrial hygienist has a variety of tools and methodologies available to conduct an environmental survey [ASTM 2014a; Flannigan et al. 2011; Hung et al. 2005]. However, many of these approaches have lacked standardization and this has made the interpretation and comparison between studies challenging [Flannigan et al. 2011]. In 2005, the American Industrial Hygiene Association (AIHA) published the second edition of the Field Guide for the Determination of Biological Contaminants in Environmental Samples [Hung et al. 2005]. This reference provides the industrial hygienist access to the most up to date methods to detect and quantify bioaerosols in the environment, and covers methods of how to conduct a survey, sample bioaerosols, and interpret the collected data [Hung et al. 2005]. Similarly, other reference sources have been published by Flannigan et al. [2011] and the American Conference of Governmental Industrial Hygienists (ACGIH) [Macher 1999] that extensively outline available methods to analyze collected bioaerosols as well as strategies to conduct an environmental survey. ASTM International has issued a wide range of standards on indoor air quality, including assessment of fungal growth and collection of bioaerosols and a guide to developing an air sampling strategy [ASTM 2009; ASTM 2014a; ASTM 2014b; ASTM 2014d]. The European Committee for Standardization has also published standards on sampling for bioaerosols and related topics [CEN 2000; CEN 2003; CEN 2004]. The sections presented below provide a very broad overview of the viable and non-viable methods available to detect bioaerosol sources that are described in the references listed above.

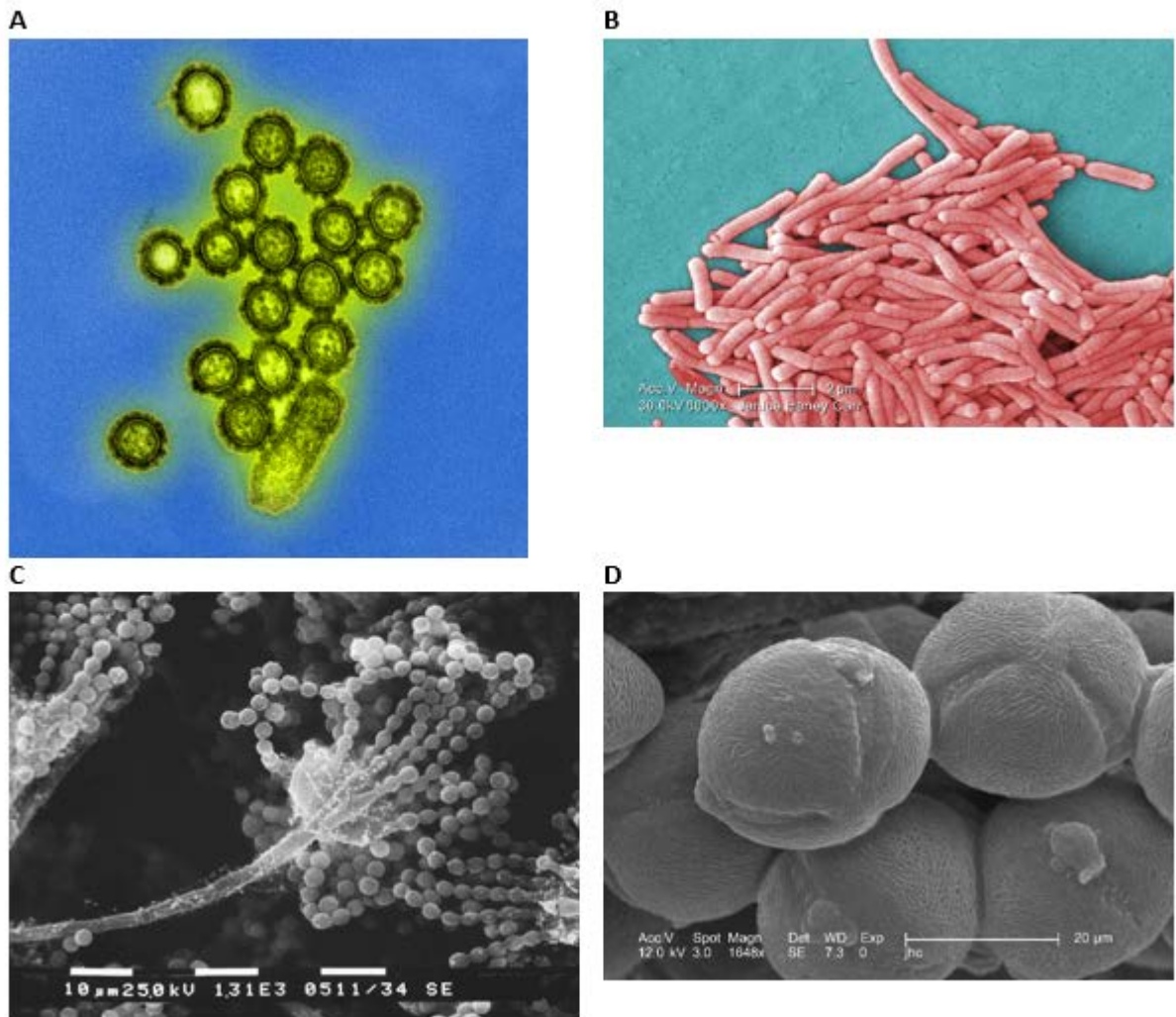

Figure 1: Photomicrographs of acellular, prokaryotic and eukaryotic microorganisms that can be encountered in occupational or industrial environments. (A) Transmission electron micrograph of Influenza/flu (H1N1) virus particles (Photo courtesy of National Institute of Allergy and Infectious Diseases; CDC Public Health Image Library (PHIL) ID#: 18156); (B) Scanning electron micrograph of bacilli derived from the Gram-negative bacteria, *Legionella pneumophila* (Photo courtesy of National Institute of Allergy and Infectious Diseases; CDC Public Health Image Library (PHIL) ID#: 11150); (C) Scanning electron micrograph of *Aspergillus* species reproductive structures including chains of asexual spores (Photo courtesy of CDC/ Robert Simmons; CDC Public Health Image Library (PHIL) ID#: 13367); and (D) Scanning electron micrograph of tricolpate pollen derived from the angiosperm plant species, *Oenothera fruticosa* (Photo courtesy of CDC/ Janice Carr, Betsy Crane; CDC Public Health Image Library (PHIL) ID#: 8729). The CDC Public Health Image Library at <http://phil.cdc.gov/Phil/home.asp> has thousands of health-related images available to the public free of charge.



2 Principles of bioaerosol collection

a. Aerodynamic diameter

The aerodynamic diameter of an airborne particle (usually written as “da” or “dae”) is the single most important parameter that determines how the particle will behave in the air, including how long it will stay airborne and where it will deposit in the respiratory system if inhaled. If a particle is falling in still air, it will reach an equilibrium velocity where the gravitational force pulling it downward is balanced by the drag force on its surface. This velocity is called the terminal settling velocity, and it depends upon the size, shape and density of the particle. The aerodynamic diameter of a particle is defined as the diameter of a sphere with unit density (that is, a density of 1 g/cm^3) that has the same terminal settling velocity as the particle. Consider, for example, the irregularly-shaped fungal fragment shown in Figure 2. Suppose this particle has a terminal settling velocity of 0.05 cm/sec . This is the same settling velocity as that of a spherical particle with a unit density that has a diameter of $4 \text{ }\mu\text{m}$. Thus, the fungal fragment is said to have an aerodynamic diameter of $4 \text{ }\mu\text{m}$. Similarly, a different particle with a terminal settling velocity of 1.21 cm/sec has an aerodynamic diameter of $20 \text{ }\mu\text{m}$, since a $20 \text{ }\mu\text{m}$ unit density sphere settles at that rate. It is important to note that the aerodynamic diameter may be very different from the physical size of a particle. A very dense and compact particle may have an aerodynamic diameter much larger than its actual dimensions, while a very light particle or one with fibrous branches may have an aerodynamic diameter that is much smaller than its physical size. It is possible for two particles to have very different shapes and physical sizes, but have the same aerodynamic diameter. Conversely, two particles may have similar physical sizes, but have very different aerodynamic diameters. A more detailed discussion of the aerodynamic diameter can be found in Hinds [1999] and Vincent [2007].

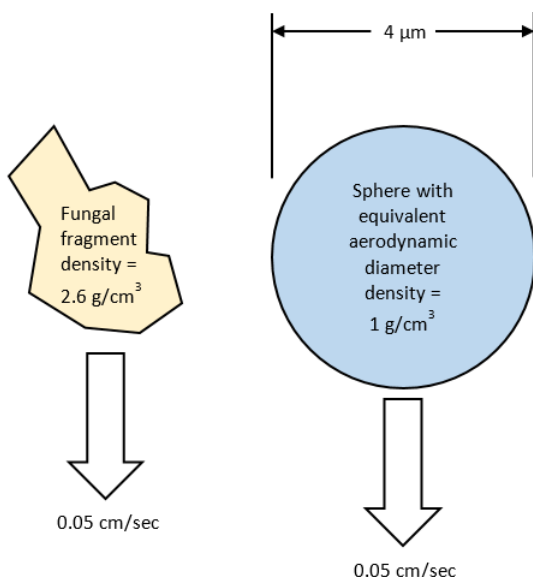

Figure 2: Aerodynamic diameter of an aerosol particle. In this case, the fungal fragment on the left is said to have an aerodynamic diameter of 4 μm , since it falls at the same terminal settling velocity as a 4 μm sphere with a unit density.

Aerodynamic diameter is used in aerosol science because particles with the same aerodynamic diameter tend to move and be collected in the same ways. For example, two particles with the same aerodynamic diameter will have the same likelihood of being collected by an impaction aerosol sampler even if they have different physical and morphological characteristics. For this reason, the performance of aerosol collection devices is usually described by giving the aerodynamic diameter of the particles that will be collected.

b. Collection efficiency and cut-off diameter

The collection efficiency of an aerosol sampler is the fraction of the aerosol particles of a particular aerodynamic diameter that will be collected by the sampler. For example, if 95% of the airborne particles with a 2 μm aerodynamic diameter that enter the sampler are deposited in the collection fluid or on the collection surface, then the sampler is said to have a 95% collection efficiency for 2 μm particles.

Most commonly-used aerosol filters have a high collection efficiency for particles of all sizes [NIOSH 2016b]. However, impactors, cyclones and impingers use the inertia of airborne particles to separate them from the air stream, and thus they have a high collection efficiency for particles with larger aerodynamic diameters and a low collection efficiency for smaller ones (Figure 3) [Hering 2001; Hinds 1999; Marple and Olson 2011]. These devices are said to have a “cut-off diameter”; that is, particles with an aerodynamic

diameter larger than the cut-off diameter are collected while particles with an aerodynamic diameter less than the cut-off diameter are not collected and pass through the device. A perfect collection device would have a 100% collection efficiency for particles larger than the cut-off diameter and 0% for smaller particles. In practice, this is not the case: the collection efficiency curve for an inertia-based sampler looks like the example curve shown in Figure 3. The aerodynamic diameter at which the collection efficiency is 50% is defined as the cut-off diameter (usually written as d_{50}). A device with a more abrupt transition from 100% to 0% collection efficiency (that is, closer to the ideal device) is said to have a sharp cut-off.

For a given inertial collection device, the 50% cut-off diameter depends upon the air flowrate through the device. Increasing the flowrate will decrease the d_{50} and shift the collection efficiency curve to the left, while decreasing the flowrate will increase the d_{50} and shift the collection efficiency curve to the right. For example, the first stage of the NIOSH two-stage cyclone aerosol sampler has a d_{50} of 4.9 μm at 2 liters/minute of air flow, 4.1 μm at 3.5 liters/minute, and 2.1 μm at 10 liters/minute [Blachere et al. 2009]. For this reason, it is important to check the air flowrate before aerosol sampling and control it during sampling so that the particles are correctly segregated by size.

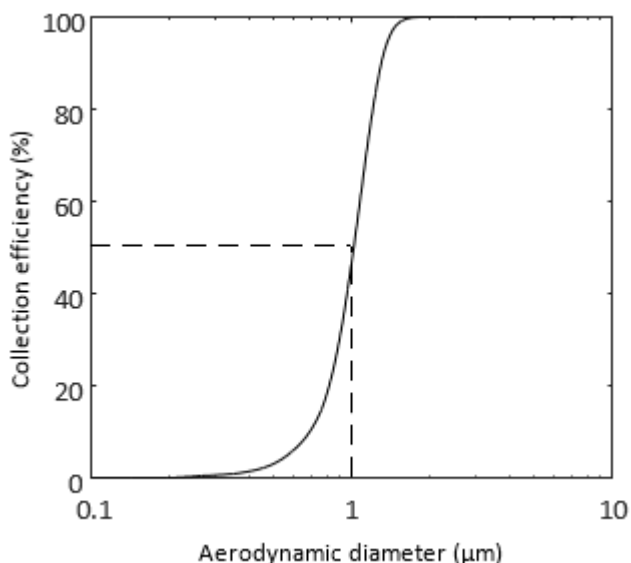
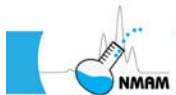

Figure 3: Example collection efficiency curve for an inertia-based aerosol sampler. Note that the collection efficiency is high for particles with large aerodynamic diameters and low for small particles. In this example, the 50% cut-off diameter (d_{50}) for this device is 1 μm .



c. Size-selective bioaerosol sampling in industrial hygiene

Size-selective bioaerosol sampling may be done for several reasons. Since the settling velocity of aerosol particles is determined by the aerodynamic diameter, knowing the size distribution of an aerosol helps in predicting how long the particles are likely to remain airborne and how far they can travel. In health care settings, for example, various medical procedures can produce a spray of droplets containing infectious microorganisms. Large droplets tend to fall onto surfaces fairly close to the source, while smaller droplets can remain airborne and carry pathogens many feet away from a patient [Davies et al. 2009; Jones and Brosseau 2015]. Another application of size-selection is to isolate different types of bioaerosol particles, such as separating fungal fragments from intact fungal spores [Adhikari et al. 2013; Seo et al. 2014].

Size-selective sampling is most commonly used to help understand the potential health effects of bioaerosol particles, which often depend upon where the particles are deposited in the respiratory tract. In general, larger bioaerosol particles tend to deposit higher in the respiratory tract (that is, in the nasal or oral cavities or larger airways), while smaller particles are able to travel deeper into the lungs to the smaller airways [Hinds 1999; Vincent 2005]. Some pathogens such as *Mycobacterium spp.*, *Bacillus spp.*, and *Aspergillus spp.* are thought to be more likely to cause a pulmonary infection if they reach the deeper airways, and the response to bioaerosols containing immunogenic material such as endotoxins or fungal antigens may also vary depending upon the site of deposition. For this reason, size-selective sampling is often used in industrial hygiene to better understand the potential risks that workplace bioaerosols present.

The American Conference of Governmental Industrial Hygienists (ACGIH), the International Organization for Standardization (ISO) and the European Standardization Committee (CEN) have defined three particle collection efficiency curves for aerosol samplers used to conduct size-selective aerosol sampling (Figure 4) [ACGIH 2001; ISO 2012; Vincent 2005]. The idea is that an aerosol sampler that conforms to one of the three criteria will collect aerosol particles in a way that approximates the fraction of particles that will reach different parts of the respiratory tract. These criteria are not specific to bioaerosols, but rather are applied to all types of aerosol particles.

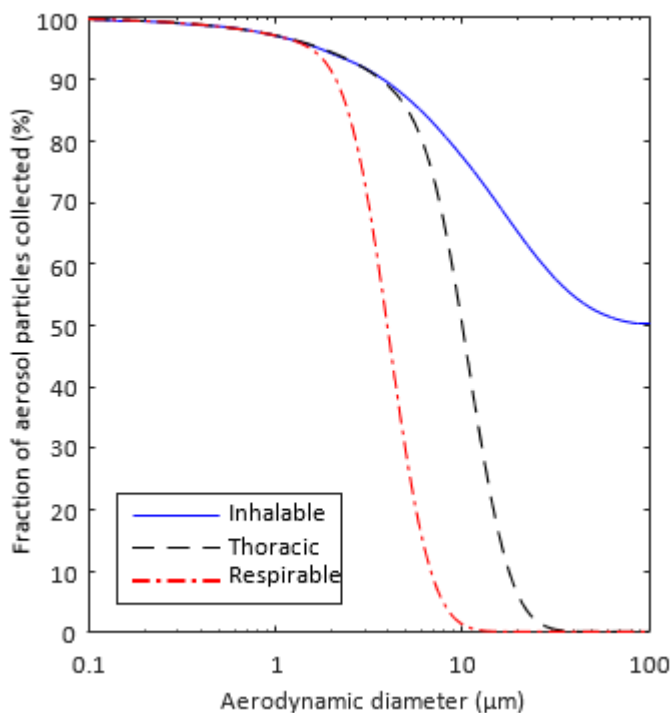
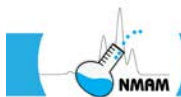

Figure 4: ACGIH/ISO sampling criteria for the inhalable, thoracic and respirable fractions of aerosol particles. The inhalable fraction contains all of the particles that are inhalable, which includes the particles in the thoracic and respirable fraction. Similarly, the thoracic fraction includes the particles in the respirable fraction. The 50% cut-off diameters are 100 µm for the inhalable fraction, 10 µm for the thoracic fraction, and 4 µm for the respirable fraction [ACGIH 2001; ISO 2012; Vincent 2005].

A sampler that collects the inhalable fraction accumulates the fraction of aerosol particles of each size that would be expected to be drawn into the nose or mouth during normal breathing. This includes larger particles that would be expected to be deposited in the nasal or oral cavities as well as smaller particles that can be conveyed to the lower airways. An aerosol sampler that conforms to the inhalable sampling criteria collects 50% of the 100 µm particles, 77% of the 10 µm particles, and 97% of the 1 µm particles in the ambient aerosol. The inhalable fraction is lower for larger particles because the greater inertia of these particles means they are less likely to be pulled into the body during inhalation. The thoracic fraction includes aerosol particles that are likely to travel into the trachea and bronchi. An aerosol sampler that conforms to the thoracic sampling criteria will collect 50% of the 10 µm particles and 97% of the 1 µm particles in the ambient aerosol. This fraction includes fewer large particles because these particles tend to be removed from the airstream by the head airways.



The respirable fraction includes aerosol particles that are able to reach the deepest airways, which are the respiratory bronchioles and the alveoli. An aerosol sampler that conforms to the respirable sampling criteria will collect 50% of the 4 μm particles, 97% of the 1 μm particles, and 99% of the 0.3 μm particles in the ambient aerosol. The respiratory bronchioles and the alveoli are of particular concern because these airways do not have cilia. Non-soluble particles that land in the nasopharyngeal region or upper airways tend to collect in the airway mucus and are removed from the respiratory tract by the cilia relatively quickly. However, particles that deposit in the alveoli and respiratory bronchioles can remain in the lungs for longer durations (in some cases, for life) unless they can be broken down or removed by migrating pulmonary macrophages. This fraction includes only the smallest particles because the larger particles are removed from the airstream by the head and thoracic airways.

It should be noted that, even though larger bioaerosol particles will tend to deposit in the upper airways and be cleared more quickly, they can still trigger an allergic/inflammatory response in susceptible individuals. Particles containing viable pathogens also commonly cause infections after being deposited in the upper airways.

When describing size-selective sampling, particles are often said to “penetrate” to a particular region of the respiratory tract. This does not mean penetrate in the sense of entering the tissue, but rather simply being present in the air stream flowing into that region, as compared to particles which were deposited before reaching a particular location. For example, an aerosol particle that is able to remain in the air stream and reach the lung alveoli is said to have penetrated to the alveolar region, even if it does not necessarily deposit there. This is the same context as with filtration, where a particle is said to penetrate a filter if it flows through the filter material and remains in the air stream. It also should be noted that the ACGIH/ISO criteria give an approximation of the fraction of aerosol particles that can penetrate to different regions of the respiratory tract. However, they do not indicate what fraction of the aerosol particles will actually deposit in the airways and what fraction will be exhaled. The lung deposition of aerosol particles is complex and depends upon many factors. More information about this topic can be found in Hinds [1999] and Vincent [2005; 2007].

3 Devices used for bioaerosol sampling

Most aerosol sampling devices involve techniques that separate particles from the air stream and collect them in or on a preselected medium. Impactors, filters, impingers and cyclones are four common sampling techniques used to separate and collect bioaerosols [Haig et al. 2016; Macher et al. 1995; Reponen et al. 2011b; Willeke and Macher 1999]. A few systems that use electrostatic precipitation or condensation-based collection are also available [Haig et al.



2016], and some real-time bioaerosol monitoring systems are available that do not require that the bioaerosol particles be isolated before analysis. Below are some specific types of bioaerosol sampling devices employed by industrial hygienists.

a. Filters

Aerosol filters are commonly used to collect bioaerosol particles because of their simplicity and low cost. Filter-based sampling is particularly useful for personal bioaerosol sampling because filter-based collectors are small and lightweight and work well with personal sampling pumps. Filters can be preceded by a size-selective inlet, such as a cyclone or impactor, to remove larger particles and provide size-classification of the bioaerosol particles. Most aerosol filter media can be classified as fibrous, membrane, or capillary pore (also called straight-through pore) [Raynor et al. 2011]. Fibrous filters are usually made of a deep mesh of glass fibers. Membrane filters are manufactured in a variety of pore sizes from polymers such as cellulose ester, polyvinyl chloride, or polytetrafluoroethylene (PTFE). Capillary pore filters are made of polycarbonate. The choice of a filter medium depends on the contaminant of interest and the requirements of the analytical technique. For gravimetric analysis, non-hygroscopic materials such as glass fibers, silver, or polyvinyl chloride membranes are selected because their masses are less affected by changes in humidity. For analysis by microscopy, cellulose ester or polycarbonate membranes are common choices because cellulose ester membranes can be rendered transparent for easier visualization, while polycarbonate filters have a smooth collection surface that works well with light or electron microscopy. Samples also can be eluted from cellulose ester and polycarbonate filters, but in some cases the recovery efficiency can be low [Eduard et al. 1990; Rule et al. 2007]. Samples to be cultured can be collected on gelatin filters, and the filters can then be dissolved in water and spread on culture plates, dissolved in growth media, or placed directly on culture plates and allowed to melt. Gelatin filters are fragile and can crack or melt in use. For analysis using immunological assays or polymerase chain reaction (PCR), PTFE filters are a common choice because they do not interfere with the assays and because samples can be readily eluted from them.

Filters are frequently described or specified using the term “pore size” or “equivalent pore diameter”. It is important to note that the filter pore size does NOT indicate the minimum particle size that will be collected by the filter; in fact, aerosol filters generally will collect particles much smaller than the nominal pore size. The mechanisms by which aerosol filters work and the role of pore size in selecting filters is described in more detail elsewhere [NIOSH 2016b].

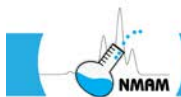

Aerosol filters are usually supplied as disks of 25, 37 or 47-mm diameter. Because the flow resistance (often called the pressure drop) of a filter increases with the air velocity through the filter, the use of a larger filter results in a lower flow resistance for a given volumetric flow rate. On the other hand, the use of a smaller filter concentrates the deposit of the contaminant onto a smaller total area, thus increasing the density of particles per unit area of filter. This may be helpful for direct microscopic examination of low concentrations of organisms, and reduces the amount of elution media needed for immunological or PCR-based assays. In areas of high concentration, the microorganisms may have to be eluted, diluted, and then refiltered for microscopic analysis. Breuer [2012] reported on the flow resistance of common aerosol filters and its relationship to sampling pump selection. Soo et al. [2016] measured the filtration characteristics and flow resistance of a variety of commonly-used aerosol filters.

In the USA, the most common method of aerosol sampling with filters is to place the filters in disposable two-piece or three-piece plastic filter cassettes with a support pad to add rigidity. The three-piece cassette may be used either in open- or closed-face modes. Open-face sampling is performed by removing the end plug and the plastic cover from the three-piece cassette and is used when the particulate matter must be uniformly deposited (i.e., for microscopic analysis). If a three-piece cassette is used in the open-face arrangement, the plastic cover is retained to protect the filter after sampling is concluded. It should be noted that the aspiration efficiencies of open-face and closed-face filter cassettes are reported to be somewhat different [Beaulieu et al. 1980; Kenny et al. 1997]. In addition to collecting on the filter, aerosol particles (especially large particles) may collect on the internal walls of the filter cassette. Depending upon the purpose of the collection, wall-deposited material may need to be included in the analysis. This can be done by using a filter with an attached capsule or by washing or wiping the internal surfaces of the cassette [Ashley and Harper 2013].

It is important to verify that the filter cassette and fittings are air-tight and have no bypass leakage around the filter. Cassettes should not be hand-assembled; they should be pressed together with a mechanical or hydraulic press. All plastic cassettes should be securely assembled and sealed with a cellulose shrink band or tape around the seams of the cassette to prevent external air leakage. The cassettes should be made of conductive or static dissipative materials to avoid losses due to electrostatic effects. More information on using filter cassettes for aerosol sampling can be found elsewhere [NIOSH 2003a; NIOSH 2016a].

b. Impactors

An impactor consists of a series of nozzles (circular- or slot-shaped) and an impaction surface [Hering 2001; Marple and Olson 2011; Marple and Willeke 1976]. Air is drawn into the impactor using a vacuum pump, and the air stream flows through the nozzles and toward the impaction surface, where particles are separated from the air stream by their inertia (Figure 5). Larger particles collect on the impaction surface, while small particles that do not impact follow the air stream. The impaction surface typically consists of a greased plate or tape, filter material, or growth media (agar) contained in Petri dishes. In some applications, impactors are not used as collection devices themselves, but rather to remove particles above a certain size before collection or characterization of the downstream aerosol.

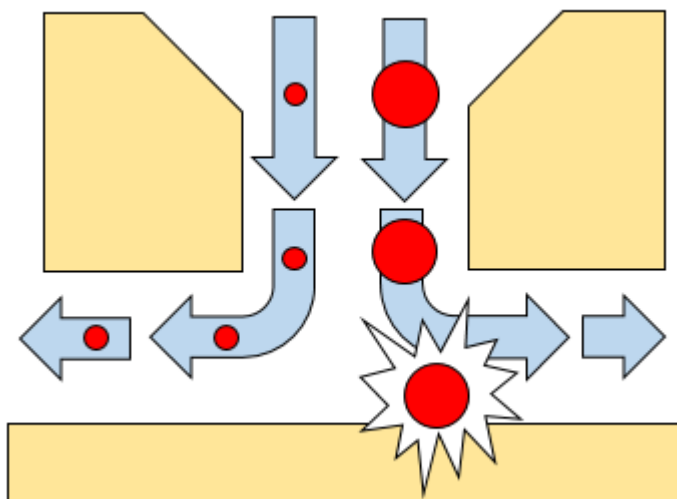

Figure 5: Impaction. As the air stream exits the impactor nozzle, it quickly changes direction as shown by the arrows. Smaller particles such as those on the left flow with the air stream and are not collected. Larger particles cannot change direction as quickly due to their higher inertia and collide with the collection surface, where they accumulate.

A cascade impactor consists of a stack of impaction stages: each stage consists of one or more nozzles and a target or substrate. The nozzles may take the form of holes or slots. Each succeeding stage has smaller nozzles and thus collects smaller particles (that is, each succeeding stage has a smaller cut-off diameter). A filter may be used after the final impaction stage to collect any particles smaller than the final cut-off diameter. If the substrate is a greased plate or filter media, it may be weighed to determine the collected mass, or it may be washed and the wash solution analyzed. If the substrate is growth media in culture plates, they may be incubated and examined for microbial growth.

The most commonly used impactor for sampling airborne culturable bacteria and fungi is the Andersen impactor, which uses from one to six impactor stages containing Petri plates as seen in Figure 6 [Andersen 1958]. Since the bioaerosol particles impact directly onto the growth media, the samplers can be directly transferred to an incubator and observed for microbial growth. However, this method depends upon collecting viable microorganisms that are capable of growth on the specific nutrient media.

Glass Petri plates are recommended for use with the Andersen impactor; plastic culture plates are often used, but this can result in loss of aerosol material due to electrostatic surface charges in the plastic [Andersen 1958; Kuo 2015]. NIOSH Method 0800 describes how to collect culturable airborne fungi and bacteria in buildings using an Andersen cascade impactor [NIOSH 2003b].

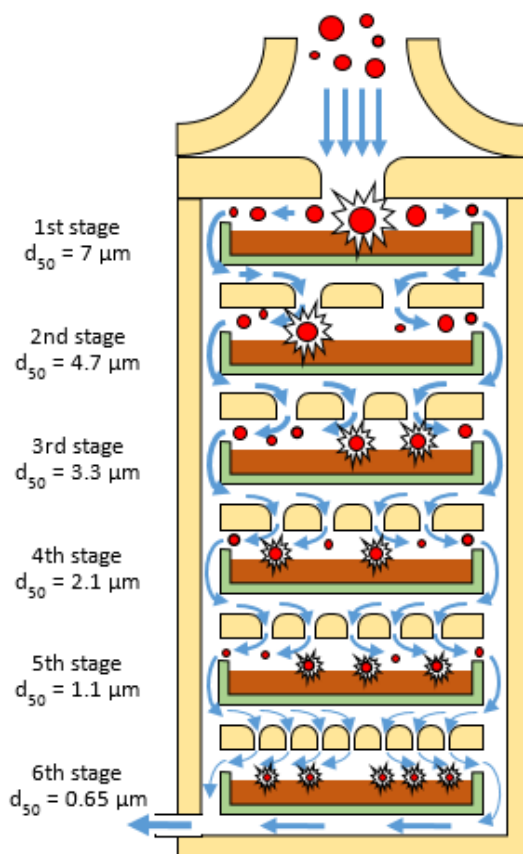
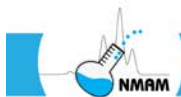

Figure 6: Schematic of a 6-stage Andersen cascade impactor [Andersen 1958]. Each stage contains a Petri plate (green) filled with nutrient agar (brown). The stages have progressively smaller nozzles, which create higher particle impaction velocities onto the agar. The aerosol particles (red) flow from the top into the first stage, where particles with aerodynamic diameters larger than 7 μm impact the agar. The remaining particles flow to the second stage, where particles with aerodynamic diameters between 7 μm and 4.7 μm are collected, and so on for the rest of the stages.



One significant advantage of the Andersen impactor is that samples can be collected directly onto culture plates and transferred to an incubator, which simplifies handling and eliminates some losses that can occur in processing. However, there are also several limitations. In low concentration environments, sampling time is limited to approximately 20 minutes to avoid drying the agar. The high flow rate (28.3 liters/minute) makes the sampler unsuitable for high concentration environments such as some agricultural sites (i.e. animal facilities) where a 1 minute sample may overwhelm the plates.

When using the Andersen impactor, it is also necessary to correct for “coincidence error” using a positive-hole correction factor. This occurs because it is possible for multiple particles, each containing one or more organisms, to pass through a particular hole during sampling and impact onto the growth medium, with one or more bacterial or fungal colonies forming at the same impaction sites. The colonies formed by the multiple particles can then be inaccurately counted as a single colony. As the number of organism-containing particles deposited onto the growth medium increases, the probability that the next organism-containing particle will impact an “occupied” hole increases. For example, if 75% of the holes have received at least one particle, the chance that the next particle will impact a “clean” hole is one in four (25%). To account for this, a probability-based coincidence correction factor needs to be applied to the results for each impactor stage. The basic formula for the coincidence correction is as follows [Andersen 1958; Macher 1989]:

$$P_r = N \left[\frac{1}{N} + \frac{1}{N-1} + \frac{1}{N-2} + \frac{1}{N-r+1} \right]$$

Where:

N = the total number of holes in the impactor stage

r = the number of colonies observed on the culture plate

P_r = the estimated culturable particle count

Andersen impactors have from one to 400 holes per stage. Macher [1989], Willeke and Macher [1999] and Andersen [1958] provide tables of positive-hole correction factors.

Investigators often employ stationary cascade impactors either as the primary collection mechanism, or as a preclassifier (for example, to remove nonrespirable particles from the sampled air stream). Marple and Willeke [1976] have reported that high velocity, inlet losses, interstage losses, and particle reentrainment affect the performance characteristics of an impactor. Particles larger than the cut-off diameter may bounce after impacting the collection surface and travel to subsequent impaction stages. This is particularly a problem with dry solid collection surfaces; for this reason, solid collection surfaces are usually greased or oiled [Hering 2001]. Fungal spores have been shown to be prone to de-aggregation and bounce when collected with an impactor, which can cause the spores to be collected on stages with smaller cut-off diameters. This can make the spore aggregates appear to have smaller aerodynamic diameters than is actually the case [Trunov et al.



2001]. Although personal cascade impactors are available, these devices are not as widely used in personal sampling for bioaerosols as are filters [Macher and Hansson 1987]. The slit-to-agar impactor is a type of impactor in which the aerosol particles are deposited on a Petri plate that slowly rotates. The rotation of the plate means that particles which are collected at different times deposit in different locations, and thus provides an indication of changes in the bioaerosol concentration over time [Ho et al. 2005; Jensen et al. 1992; Smid et al. 1989; USP 1997]. Examples of slit-to-agar samplers include the Dycor Slit Sampler from Dycor and the Air Trace Environmental Slit-to-Agar Sampler from Particle Measuring Systems.

The Hirst/Burkard spore trap has been widely used to collect outdoor aerospora. It was first described by Hirst [1952] and consists of a unit that houses a vacuum pump and rotating drum that is lined with polyester tape. The drum rotates at 2 mm per hour and is continuously run for seven days. Bioaerosols pass through an orifice on the sampler and particles impact on the tape. Following the seven-day sampling interval, the tape is removed and cut in 48 mm intervals that correspond to individual sampling days. Bioaerosols deposited on the tape are stained and then resolved, identified, and quantified using bright field microscopy.

[Tovey et al. 2016] developed a personal aerosol sampler with a rotating surface that allows time-resolved collection of aerosol particles onto an electret strip or an adhesive film. They used the sampler to study personal exposures to dust mite allergens over time. A novel example of an impaction-based personal bioaerosol sampler is the intranasal air sampler fabricated by Graham et al. [2000], which fits within the intranasal cavity of the subject. Bioaerosols enter the nasal cavity following inhalation and pass through slits where particles are deposited by impaction on either an adhesive backed tape or collection cup lined with silicon grease. This impaction sampler has been utilized in a number of studies that have evaluated exposure to indoor and occupationally relevant aeroallergen sources [Gore et al. 2002; Mitakakis et al. 2000; Renstrom et al. 2002].

Other impaction-based approaches have also been used in the assessment of outdoor bioaerosols, including the Rotorod, Air-o-cell and Allergenco samplers [Frenz 1999; Lee et al. 2004a; Pityn and Anderson 2013; Portnoy et al. 2000]. ASTM Standards D7391 and D7788 discuss the collection and analysis of airborne fungal structures by inertial impaction [ASTM 2009; ASTM 2014d].

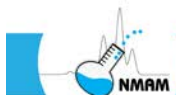

c. Cyclones

A cyclone sampler consists of a circular chamber with the aerosol stream entering through one or more tangential nozzles as shown in Figure 7 [Hering 2001]. Like an impactor, a cyclone sampler depends upon the inertia of the particle to cause it to deposit on the sampler wall as the air stream curves around inside the chamber. Also like an impactor, a cyclone sampler has a collection efficiency curve like the one shown in Figure 3, and the collection efficiency curve depends upon the flow rate. Cyclones are less prone to particle bounce than impactors and can collect larger quantities of material. They also may provide a more gentle collection than impactors, which can improve the recovery of viable microorganisms. However, cyclones tend to have collection efficiency curves that are less sharp than impactors, and it is simpler to design a compact cascade impactor compared to a cascade of cyclone samplers.

In industrial hygiene, cyclone aerosol samplers are frequently used in conjunction with a filter to conduct size-selective aerosol sampling [Hering 2001]. For example, in NIOSH Method 0600, a cyclone is used to remove the non-respirable fraction from the aerosol (following the ACGIH/ISO criteria described earlier), and a filter is then used to collect the respirable fraction [NIOSH 2003c]. A sampler developed at NIOSH uses two cyclones followed by a filter; the first cyclone collects the non-respirable fraction of the particles, the second cyclone collects the respirable particles $> 1 \mu\text{m}$, and the filter collects particles $< 1 \mu\text{m}$ [Blachere et al. 2009]. The NIOSH cyclone aerosol samplers have been used in applications including measurements of airborne viruses in healthcare settings; airborne fungi and fungal fragments in residences; airborne dimorphic fungal pathogens such as *Paracoccidioides brasiliensis* in Brazil, and bioaerosols in agricultural operations [Arantes et al. 2013; Blachere et al. 2009; Blais Lecours et al. 2012; Kettleison et al. 2013; Lee and Liao 2014; Lindsley et al. 2010a; Lindsley et al. 2010b; Martin et al. 2015; Seo et al. 2014; Singh et al. 2011a; Singh et al. 2011b].

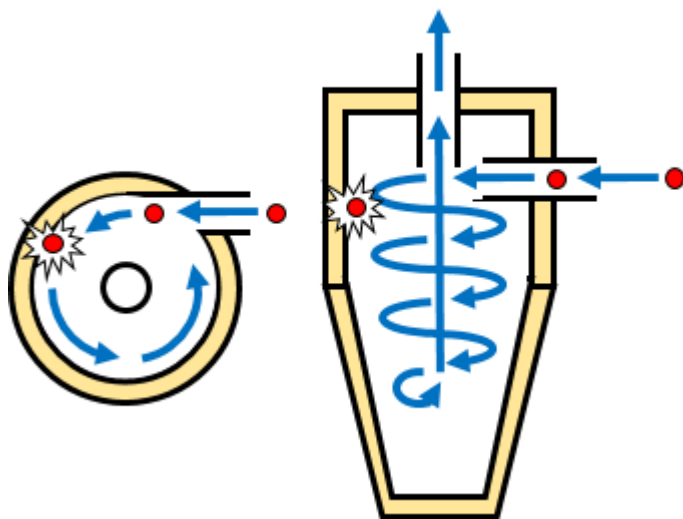

Figure 7: Cyclone aerosol collection. When the aerosol stream enters the body of the cyclone through the inlet, the air flow follows the curved interior wall and flows in a spiral pattern. If aerosol particles are larger than the cut-off diameter, then the inertia of the particles causes them to collide with the wall of the cyclone and accumulate. After spiraling downward, the air flow comes up through the center of the cyclone and exits through the outlet (called a vortex finder) at the top. The illustration shows a tangential inlet reversed-flow cyclone, which is the most common type of cyclone sampler.

d. Impingers

Many microorganisms can lose their viability if they are collected onto dry solid surfaces or filters because of impact damage and desiccation [Cox 1987; Jensen et al. 1992; Macher and First 1984; Verreault et al. 2008; Wang et al. 2001]. One way to avoid this is to collect culturable bioaerosols in liquids using an impinger [Henningson and Ahlberg 1994; Henningson et al. 1988; Lembke et al. 1981; Reponen et al. 2011b; Verreault et al. 2008]. A typical impinger is shown in Figure 8. The body of the impinger is filled with a collection liquid, and the aerosol stream flows down through a nozzle and enters the liquid at a high velocity. The aerosol particles are collected when they collide with the bottom of the collection vessel or disperse into the liquid. Impingers often have curved inlets to remove larger particles from the air stream before collection. Because impingers are essentially another type of inertial collection device, they have a collection efficiency curve and a cut-off diameter like impactors and cyclones. However, the collection efficiency curves tend to be less sharp. The high velocity air stream directed into the liquid also creates considerable agitation and can produce foaming if the collection liquid contains surfactants. Additives to the collection medium such as proteins, antifoam, or antifreeze aid in resuscitation of bacterial cells, prevent foaming and loss of the collection fluid, and minimize injury to the cells [Chang and Chou 2011; Cown et al. 1957; Dungan and Leytem 2015]. The presence

of proteins and other additives can also greatly influence the survival of airborne viruses during collection by impingers [Ijaz et al. 1985b; Schaffer et al. 1976; Verreault et al. 2008]. Water loss over time reduces the liquid level in the impinger and increases the concentration of the non-volatile components, which limits the available collection time [Lin et al. 1997]. Sample losses due to re-aerosolization and particle deposition inside the impinger can be significant [Grinshpun et al. 1997; Han and Mainelis 2012].

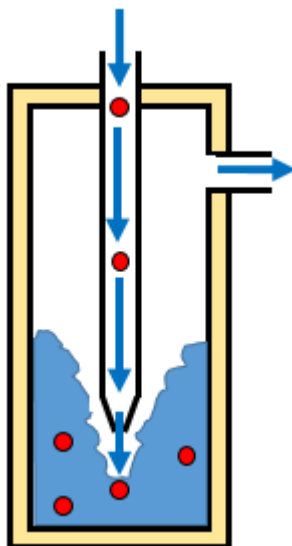
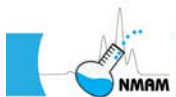

Figure 8: Impingement. Bioaerosol particles exit the nozzle of the impinger at high velocity and impact the liquid or the bottom surface of the collection vessel. Some types of impingers produce air bubbles in the collection media, which can enhance particle collection, but can damage some types of microorganisms.

Two common impingers used for bioaerosol sampling are the Greenburg-Smith impinger [Greenburg 1932] and the All-Glass Impinger with the nozzle 30 mm above the base of the collection vessel, called the AGI-30 [May and Harper 1957]. The Greenburg-Smith and AGI-30 samplers operate by drawing aerosols at nominal flow rates of 28.3 and 12.5 L/min, respectively, through an inlet tube [Macher et al. 1995]. The AGI-30 inlet tube is curved to simulate particle collection in the nasal passage [Cox 1987]. Investigators have reported problems with low sampling efficiencies and high losses due to particles in the collection being re-aerosolized and lost [Grinshpun et al. 1997; Kesavan et al. 2010; Lin et al. 1997].

When the AGI-30 is used to recover total airborne organisms from the environment, the curved inlet tube is washed with a known amount of collecting fluid after sampling because larger particles (i.e., over 15 μm) are collected on the tube wall by inertial force. After sampling for the appropriate amount of time, 10 mL of the full-strength collection



fluid is filtered through a 0.45- μm pore size membrane filter. Serial dilutions of the remaining collection fluid are handled similarly [Greenberg et al. 1992]. The membrane filters are placed in sterile plastic petri plates filled with the appropriate medium and incubated for later identification and enumeration.

e. Wetted-surface bioaerosol samplers

Several types of bioaerosol sampling devices have been developed in which the aerosol stream impacts onto a wetted surface or onto the wall of a cyclone wetted with collection media [Kesavan and Sagripanti 2015; Kesavan et al. 2011]. These systems largely avoid the bubbling and agitation associated with conventional impingers, which may be detrimental to some microorganisms [Lin et al. 2000], and can provide sharper collection efficiency curves. One of the simplest examples of a wetted-surface sampler is the SKC BioSampler [Lin et al. 2000; Willeke et al. 1998]. It is similar to an AGI-30, except that it has three nozzles that curve so that the aerosol stream is tangential to the wall of the collection vessel. This causes the collection liquid to swirl and greatly reduces the agitation, bubbling and consequent reentrainment seen with the AGI-30. The BioSampler collects particles with aerodynamic diameters of approximately 0.3 μm to 8 μm into the collection media, although the upper cut-off diameter is not sharp [Hogan et al. 2005; Kesavan et al. 2010; Willeke et al. 1998]. The BioSampler reportedly can be used with non-evaporating fluids such as mineral oil to eliminate the collection time limits imposed by water evaporation, provided that the microorganism can survive collection and processing [Lin et al. 2000]. Alternatively, fluid can be exchanged or added to the sampler as needed [Rule et al. 2005; Rule et al. 2007].

The CIP10-M, a modified version of the CIP10 aerosol sampler, collects airborne microorganisms in a liquid layer on the interior surface of a rapidly-rotating cup. As with the BioSampler, the CIP10-M can be used with mineral oil as the collection fluid to avoid fluid evaporation. It is reported to have collection efficiencies of >80% for particles >2.8 μm , 50% for 2.1 μm particles, and <10% for particles of <1 μm [Görner et al. 2006; Simon et al. 2016].

May [1966] designed a three-stage sampler in which aerosol particles are collected by impaction onto a wetted fritted surface in the first two stages and the third stage is a swirling aerosol collector similar to the BioSampler. Both glass and stainless steel versions are available. In his original report, May [1966] used particles with a density of 1.5 g/cm^3 and reported cut-off sizes of 6 μm , 3.3 μm and 0.7 μm , which correspond to aerodynamic diameters of about 7.3 μm , 4 μm , and 0.86 μm . The May sampler is reported to give comparable results to the Andersen impactor [Zimmerman et al. 1987].

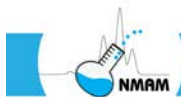

Several wetted-surface bioaerosol samplers recirculate the collection fluid and add additional fluid as needed to replace evaporative losses. This extends the collection time available and allows the concentration of the aerosol from a large volume of air at a high flow rate into a relatively small volume of liquid, which is of great advantage when searching for pathogens that may be present in very low concentrations. For this reason, such systems are often used for bioterrorism and homeland security applications. The Coriolis sampler [Carvalho et al. 2008], the OMNI-3000 [Zhao et al. 2014], the SASS 2000 [Ravva et al. 2012], and the SpinCon [Yooseph et al. 2013] use a wetted wall cyclone for bioaerosol collection, while the BioCapture 650 [Ryan et al. 2009] collects particles onto a wetted rotating impactor. Kesavan and Sagripanti [2015] reported the results of performance tests for several of these types of bioaerosol samplers.

When conducting long-term bioaerosol collection into liquid media, it is important to note that if the collected bioaerosol particles remain in the collection media for an extended time and if steps are not taken to inhibit growth, spore germination and cell amplification of some fungi and bacteria can occur. This can result in the appearance of much higher bioaerosol concentrations than are actually present in the environment.

f. Condensation-based bioaerosol samplers

Some bioaerosol particles are too small to be readily collected by impactors or impingers. These particles can be collected using filters, but filter collection can reduce the viability of microorganisms. One solution is to humidify the aerosol stream and then cool it, which causes water vapor to condense on the aerosol particles and create a droplet surrounding the particle. This larger particle can then be collected by impaction or impingement, as shown in Figure 9. This is similar in principle to condensation-based particle counters, which are used to measure the concentration of small airborne particles. Some researchers showed that adding water vapor to an aerosol stream enhanced the recovery of airborne viruses and bacteriophages, which may work by this method (although this is unclear) [Hatch and Warren 1969; Trouwborst and Kuyper 1974; Warren et al. 1969]. More recently, Milton developed a condensation-based system to collect fine particles containing influenza virus from the exhaled breath of human subjects [McDevitt et al. 2013; Milton et al. 2013]. A condensation-based bioaerosol sampler called a growth-tube collector has been used to collect MS2 bacteriophage and influenza virus in the laboratory, and is reported to be especially effective at recovering viable virus in sub-micrometer particles [Lednicky et al. 2016; Pan et al. 2016; Walls et al. 2016]. A version of this system called the Spot Sampler (Aerosol Devices, Inc.) is commercially available.

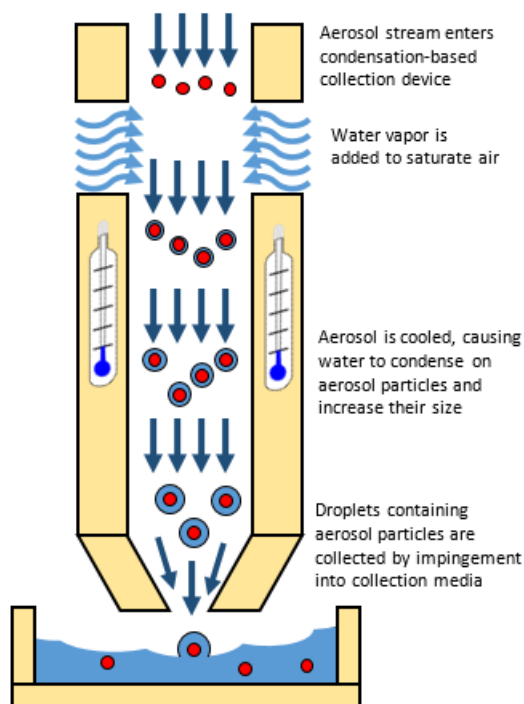
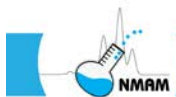

Figure 9: Condensation-based aerosol particle collector.

g. Electrostatic samplers

Electrostatic precipitation works by using a strong electric field to create a high concentration of unipolar ions. The rapid motion of these ions causes them to collide with and charge airborne particles, and the resulting charge on the particles causes them to be attracted to the collection surface [Hinds 1999]. Electrostatic precipitation systems have been used to collect bioaerosol particles such as allergens, bacteria and viruses [Artenstein et al. 1968; Artenstein et al. 1967; Custis et al. 2003; Donaldson et al. 1982; Heitkamp et al. 2006; Lee et al. 2004b; Parvaneh et al. 2000; Roux et al. 2013]. Such devices offer simplicity of design with few moving parts, and are generally effective at collecting small particles. One electrostatic bioaerosol sampling device is available commercially from Inspirotec [Gordon et al. 2015].

Some electrostatic bioaerosol samplers collect particles into liquid to concentrate the particles and help preserve the viability of microorganisms. The Large Volume Air Sampler (LVS) developed by Litton in the 1960's washed the collection surface with recirculating fluid; this sampler was successfully used to collect pathogenic respiratory bacteria and viruses in a variety of settings [Artenstein et al. 1968; Artenstein et al. 1967; Donaldson et al. 1982]. Pardon et al. [2015] developed a system that collects particles directly on a microfluidic chip. The electrostatic aerosol collector devised by Han et al. [2015] collects the deposited aerosol into rolling water droplets, which greatly



concentrates the particles. The Aerosol-to-Liquid Particle Extraction System (ALPES) uses an electrostatic system to collect aerosol particles into recirculating liquid, which helps preserve the viability of microorganisms [Heitkamp et al. 2006].

Electrostatically-charged cloths are used to collect airborne particles that settle onto them, and also to wipe settled dust from surfaces. These are discussed in the next two sections.

h. Passive bioaerosol samplers

Passive bioaerosol sampling refers to the collection of bioaerosols by allowing them to gravitationally settle onto a collection device, such as a culture plate, foil sheet, electret-based filter or electrostatically-charged cloth. Compared to active sampling, passive bioaerosol sampling has several advantages, including simplicity, low cost, lack of disturbance of the surrounding air, and the ability to collect for extended time periods [Haig et al. 2016; Pasquarella et al. 2000; Vincent 2007].

Passive bioaerosol sampling can be limited by several variables including the air currents around the device and airborne particle size. As discussed earlier, large particles settle much more quickly than small particles. Thus, large particles are much more likely to be collected by passive samplers [Haig et al. 2016; Reponen et al. 2011b]. As a result of these limiting variables, results from passive bioaerosol sampling cannot be directly related to the concentration of airborne particles and may not correlate well with results from active sampling [Reponen et al. 2011b]. However, some authors have proposed that passive sampling may be useful in evaluating the likelihood that bioaerosol particles will contaminate surfaces such as open wounds in operating rooms, since they mimic the contamination event more closely than does an active sampler [Friberg et al. 1999; Haig et al. 2016; Pasquarella et al. 2000].

Passive bioaerosol collectors are often placed 1.5 to 2 meters above the ground to avoid collection of large dust particles from sources other than airborne particles, such shoes, clothing, skin and animals [Frankel et al. 2012; Liroy et al. 2002; Noss et al. 2008; Rintala et al. 2012]. Grills, screens or shields may also be placed around or over the collection device to screen out large debris [Brown et al. 1996; Wagner and Macher 2003; Whitehead and Leith 2008; Wurtz et al. 2005].

1.) Settle plates

Settle plates (also called settling plates or sedimentation plates) are culture plates containing nutrient agar that are opened and placed collection-side up in a location of interest. Airborne particles are allowed to settle onto the plates for a specified time, and the plates are then closed, incubated and inspected for growth. Settle plates are

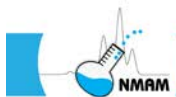

commonly used to assess airborne microbial contamination and are listed in methods and standards from the ISO, the American Public Health Association (APHA) and the United States Pharmacopeia (USP) [Dyer et al. 2004; ISO 2003; USP 1997]. However, because the results from settle plates cannot be directly compared to the amount of airborne microbes, they should only be used for qualitative, not quantitative, evaluations. The CDC recommends the use of high-volume air samplers rather than settle plates when investigating airborne fungal spore contamination in health care facilities [CDC 2003].

Settle plate methods suffer from a lack of standardization of methodology, which makes results difficult to compare. Pasquarella et al. [2000] reviewed the use of settle plates and proposed an Index of Microbial Contamination (IMA) to standardize the use of settling plates. To measure the IMA, 90 mm culture plates are placed 1 meter above the floor and 1 meter from any walls, and collect settled particles for 1 hour (called the 1/1/1 scheme). The number of colony-forming units (CFUs) detected on each plate is then used to calculate the IMA in CFUs/dm²/hour [Pasquarella et al. 2000].

2.) **Electrostatic dust collectors**

Noss et al. [2008] developed a method called the electrostatic dustfall collector (EDC) that collects settling airborne particles onto four electrostatically-charged cloths. EDC's have been used in studies of culturable bacteria and fungi, endotoxin, glucan and inflammatory mediators in airborne particles [Adams et al. 2015; Frankel et al. 2012; Huttunen et al. 2016; Kilburg-Basnyat et al. 2016; Kilburg-Basnyat et al. 2015; Noss et al. 2010; Noss et al. 2008]. Noss et al. [2008] and Frankel et al. [2012] reported good correlations between the EDC and active aerosol samplers. Adams et al. [2015] compared EDC's to Petri dishes and other passive collection materials and found that the results correlated reasonably well, but that a rigorous extraction protocol was required to get consistent results from the EDC's. Brown et al. [1996] developed a passive electrostatic-based personal aerosol sampler and reported that it gave a reasonable correlation with inhalable dust measurements at farms and a rubber plant.

3.) **Other passive bioaerosol samplers**

The UNC Passive Aerosol Sampler consists of a 6.8 mm diameter collection substrate mounted on a scanning-electron microscope stub and shielded by a protective screen [Wagner and Macher 2003; Whitehead and Leith 2008]. Airborne particles settle or diffuse onto the substrate and can be analyzed by optical or electron microscopy. Other investigators have used aluminum sheets in boxes, Petri dishes, and sheets of various plastic materials as passive bioaerosol collectors [Adams et al. 2015; Meadow et al. 2015; Wurtz et al. 2005].

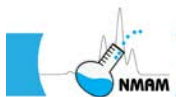

i. Settled dust collection devices

The collection and analysis of dust that has settled onto floors, carpets, and other surfaces is widely used as a means of identifying bioaerosols in buildings, especially allergens, endotoxin and molds [Hung et al. 2005; Lioy et al. 2002; Martyny et al. 1999; Morey 2007; Rintala et al. 2012]. Settled dust sampling allows for the collection of large quantities of material, provides a long-term sample, and does not require a dedicated sampling device for each location. Dust assays allow quantitative data to be generated per weight and surface area of dust. Some investigators find it useful to compare different sites in a building or to sample before and after remediation efforts to see if the source of a bioaerosol has been eliminated.

Settled dust will vary within a building depending upon the location and collection surface [Lioy et al. 2002; Rintala et al. 2012]. In addition to settling from the air, dust can be produced by a variety of other mechanisms, making it difficult to distinguish the source. Floor and carpet dust, for example, will include outside material brought in by shoes, skin flakes, clothing fibers and animal dander. Sampling locations well above floor level are often chosen to minimize the amount of dust that is not from settled airborne particles [Frankel et al. 2012; Rintala et al. 2012].

1.) Vacuums

The US Department of Housing and Urban Development has developed a protocol for the vacuum collection of home dust samples to test for allergens [HUD 2008].

Vacuum collection of settled dust from floors and carpets has been used to determine the Environmental Relative Moldiness Index (ERMI), which is a measure of mold contamination in homes [Kettleson et al. 2015; Reponen et al. 2012; Reponen et al. 2011a; Taubel et al. 2016; Vesper et al. 2013; Vesper et al. 2007]. ERMI is discussed in more detail later in this chapter. Note that vacuuming can increase the levels of bioaerosols in a location. Thus, air sampling should be completed before collecting surface samples by vacuuming [Hung et al. 2005; Hunter et al. 1988].

2.) Swabs

Swabs are widely used to collect airborne material that has settled onto surfaces. Swabs are also used to identify microbial contaminants that may be colonizing building materials within the indoor environment. However, obtaining consistent and reliable results from swab sampling is far more difficult than is often appreciated, and careful attention is needed to the choice of swab material, elution media, and method of swabbing. If swab samples are to be cultured, aseptic technique is needed to avoid contamination. ASTM International has a standard for collecting fungal material by swab [ASTM 2012]. The APHA has published a standard method for swab sampling of

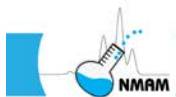

food-contact surfaces [Dyer et al. 2004], while the USP and ISO have standards that include swab sampling for microbiological contamination in clean rooms [ISO 2003; USP 1997].

An example of a validated protocol for swab sampling is that provided by NIOSH for surface sampling for *Bacillus anthracis* spores [Hodges et al. 2010; Hodges et al. 2006; NIOSH 2012b]. In this procedure, a defined area is first outlined using a template or a ruler and masking tape. A sterile macrofoam swab is then moistened using a buffer solution that neutralizes disinfectants. The surface is swabbed using horizontal strokes, followed by vertical strokes, and finally diagonal strokes, and the swab is then placed in a sterile tube for transport and analysis. Aseptic technique is used throughout the procedure.

The choice of swab material can have a significant impact on the collection of microorganisms from a surface. Moore and Griffith [2007] studied the recovery of *Escherichia coli* and *Staphylococcus aureus* from stainless steel squares using nylon-flocked swabs and spatulas, cotton swabs and rayon swabs. They reported that nylon-flocked and cotton swabs were equally effective at removing bacteria from dry surfaces, but that cotton swabs removed bacteria more effectively from wet surfaces than rayon or nylon-flocked swabs. However, nylon-flocked swabs and spatulas released the bacteria into the elution media more readily than rayon swabs, which in turn released more bacteria than cotton swabs. For viruses, polyester-tipped swabs were found to be more effective than cotton swabs or antistatic wipes at recovering MS2 bacteriophage from stainless steel and plastic [Julian et al. 2011], while macrofoam swabs performed best when recovering wet or dried norovirus from stainless steel surfaces, followed by cotton, rayon and polyester swabs [Park et al. 2015].

The elution media used to wet the swabs and recover the bacteria from the swabs also can have a substantial effect on sampling. Moore and Griffith [2007] tested eleven different swab wetting solutions containing various combinations of salts, surfactants and nutrients. They found that the recovery efficiency varied widely depending upon the species of bacteria, type of swab, and whether the surface was wet or dry. For MS2 bacteriophage, saline or Ringer's solution (an isotonic salt solution) worked better than viral transport media or pure water [Julian et al. 2011]. It is important to note that the elution media must both remove the biological material from the surface and subsequently elute it from the swab in order to be effective.

Although they may be overlooked, storage conditions play an important role in swab sampling. After sample collection, room temperature storage of moist swabs may lead

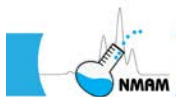

to microbial growth if the elution media or swab contain nutrients, while the presence of chemicals such as Tween 80 may reduce viability over time. These problems can be alleviated by placing the swabs in cold storage as quickly as possible [Moore and Griffith 2007].

3.) Wipes

All of the considerations and limitations of swab sampling also apply to wipe sampling. Swabs are typically more useful for small surfaces and hard-to-reach locations, while wipes are more effective at collecting dust from large non-porous surfaces [NIOSH 2012b]. Electrostatic wipes have been used to collect settled dust for studies of mold and endotoxin [Bolaños-Rosero et al. 2013; Thorne et al. 2005]. However, Thorne et al. [2005] found that wipes and gloves themselves were frequently contaminated with endotoxin and needed to be tested before use.

4.) Adhesive tape

Adhesive tape can be used to collect dust samples from surfaces for microscopic examination (this is called tape lift or cello tape sampling) [ASTM 2014c; Martyny et al. 1999; Morey 2007]. Typically, a section of adhesive tape is gently pressed onto a surface of interest, removed with a slow steady force, and then attached to a glass slide or placed in a vial. The samples are relatively simple to collect, but the results depend upon the ability of the examiner to identify microorganisms and their fragments, and do not provide a quantitative assessment of exposure.

5.) Contact plates

Contact plates are typically round culture plates in which the agar is poured so that the top of the agar forms a meniscus slightly above the top rim of the plate. A surface sample is collected by inverting the plate and pressing the agar directly onto a flat surface of interest. The plate is then removed, incubated and inspected for microbial growth. This sampling method is often called the replicate organism direct agar contact (RODAC) procedure, and it is commonly used for biocontamination monitoring in the pharmaceutical and food industries [Dyer et al. 2004; ISO 2003; USP 1997]. Because many of the surfaces of interest in these industries are routinely disinfected, contact plates are available with agars that contain neutralizers for disinfectants. One report indicated that nitrocellulose membranes were slightly more effective than RODAC plates at surface sampling, and are easier to use on curved surfaces [Poletti et al. 1999].

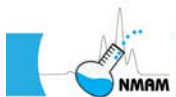

j. Heating, ventilation and air conditioning (HVAC) filters

Building HVAC systems filter large quantities of outside and recirculated inside air as they maintain environmental conditions inside buildings. Researchers have taken advantage of these existing filtration systems as a way to study bioaerosols in a variety of structures [Goyal et al. 2011; Haaland and Siegel 2016; Noris et al. 2011]. Testing the collected particulate material on HVAC filters provides an inexpensive way of studying bioaerosols collected from large volumes of air over long time periods. However, some limitations must be kept in mind. Extracting bioaerosols from these filters can be difficult and the methods require validation [Farnsworth et al. 2006]. Many microorganisms lose viability after collection, so although PCR-based methods may be effective, culture-based methods likely will not work except for very hardy microbes [Farnsworth et al. 2006]. Finally, commonly-used HVAC filters can have relatively low collection efficiencies, especially for small particles [ASHRAE 2009]. Haaland and Siegel [2016] reviewed 60 studies in which HVAC filter analyses were used to study bioaerosols in buildings.

k. Real-time bioaerosol monitoring

Many biological molecules have an intrinsic autofluorescence, and this phenomenon has been used as the basis for continuous real-time bioaerosol detection systems [Pöhlker et al. 2012]. This technique is most commonly employed for studies of atmospheric bioaerosol particles and for biodefense and biosecurity applications. These systems can distinguish biological from non-biological particles, and can usually provide information about the particle size and some characteristics of the bioaerosols. One device, the TSI Ultraviolet Aerodynamic Particle Sizer (UV-APS), was used in several studies [Bhangar et al. 2016; Hairston et al. 1997; Kanaani et al. 2008]; it has been replaced by an updated version called the Fluorescence Aerosol Particle Sensor (FLAPS) III. Other real-time bioaerosol detectors include the BioScout [Saari et al. 2014], the Wideband Integrated Bioaerosol Sensor (WIBS-4) [Toprak and Schnaiter 2013], and the Fido B2 (formerly called the Instantaneous Bioaerosol Analysis and Collection, IBAC) [Santarpia et al. 2013].

4 Considerations for bioaerosol sampling

a. Development of a bioaerosol sampling strategy

The first step in designing a sampling strategy for bioaerosol sampling is to determine the purpose of the sampling [ASTM 2014a]. For example, bioaerosol sampling may be conducted to estimate worker exposure to bioaerosols, or to select or evaluate engineering controls to reduce exposures, or to identify the source of a bioaerosol. A sampling strategy then should begin with an overview of the site of interest and development of initial hypotheses regarding the types, sources and distributions of bioaerosols. After this, the sampling methods, times, durations, and the analytical methods can be selected. Note that

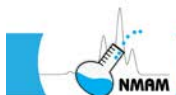

bioaerosol sampling is almost always done in conjunction with the collection of other types of data, such as worker health information, visual observations, air flow measurements, surface sampling, and information about possible sources.

b. Sampling locations

The sampling locations should be selected to assist in evaluation of the working hypotheses about possible exposures [ASTM 2014a]. If worker exposures are being evaluated, then the samplers should be placed in areas occupied by the workers. If contamination of a ventilation system is being examined, then sampling in the system and at the ventilation louvers would be appropriate. Care must be exercised to ensure that people do not tamper with the samplers and that microorganisms on surfaces or in duct work are not inadvertently aerosolized.

Bioaerosol samples should be drawn directly into the sampler rather than being transported to the sampler by tubing. If transport tubing must be used, it should be as short and straight as possible. Abrupt flow constrictions and bends in the tubing should be especially avoided, as considerable sample deposition can occur at these locations. The tubing diameter should be large enough that the flow is not turbulent and that the d50 of any bends is well above the size of the bioaerosol particles [Pui et al. 1987; Tsai and Pui 1990]. The tubing should be made of a material that does not lead to losses through electrostatic deposition [Liu et al. 1985]. A review of the many issues surrounding the transporting of aerosols through sampling lines is provided by Brockmann [2011].

Personal aerosol sampling provides a much better representation of worker and resident exposure to aerosol particles than area (static) sampling [Cherrie et al. 2011; Kissell and Sacks 2002; Rodes and Thornburg 2005]. However, most samplers for viable bioaerosols do not lend themselves to personal sampling. Thus, a combination of personal and area sampling may be necessary to fully characterize the exposure [Toivola et al. 2002].

c. Concentrations of indoor and outdoor bioaerosols

Indoor bioaerosol sampling is conducted in occupational (industrial, education, and office environments) and non-occupational (residential and buildings) settings. Outdoor bioaerosol sampling is often performed to provide comparative data for indoor sampling and to help determine possible sources of contaminants. Outdoor bioaerosol sampling also is conducted in occupational environments such as agricultural settings, composting sites and sewage treatment plants [Environment Agency 2009; Lee and Liao 2014; Masclaux et al. 2014]. In addition, outdoor sampling may be performed for pollen and fungi to assist allergists in their treatment of patients by identifying taxa distribution and concentrations in air over time.

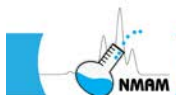

The concentrations of bioaerosol particles vary widely depending upon the meteorological parameters, the location of sources, the time of year and the amount of ventilation. Shelton et al. [2002] studied 1,717 buildings in the United States. They found that outdoor levels of airborne fungi are usually higher than indoor levels, and that fungal levels were highest in the fall and summer and lowest in the winter and spring. Outdoor levels varied from 1 to more than 8,200 colony-forming units (CFU)/m³ of air, with a median of 540 CFU/m³. Indoor levels ranged from 1 to over 10,000 CFU/m³, with a median of 82 CFU/m³. An examination of fungi in flood-damaged homes found fungal concentrations of 1,100 to 8,400 spores/m³ outside and 500 to 101,100 spores/m³ inside [Reponen et al. 2007]. An investigation of 100 large office buildings by Tsai and Macher [2005] found that airborne bacterial concentrations tend to be higher outdoors than indoor (except for Gram-positive cocci). Outdoor concentrations tended to be higher in the winter (194 vs. 165 CFU/m³), while indoor concentrations were higher in the summer (116 vs. 87 CFU/m³). Forty-one percent of the bioaerosol samples were below the detection limit, and >95% of the culturable bacteria were mesophilic (grow at moderate temperatures). In a report on agricultural workers working in animal confinements, Lee et al. [2006] found breathing zone culturable bioaerosol exposures of 300 to 36,000 CFU/m³ for fungi, 3000 to 3.3 x 10⁸ CFU/m³ for bacteria, and up to 2,800 CFU/m³ for actinomycetes. During grain harvesting, workers were exposed to culturable bioaerosol levels of 82,000 to 7.4 x 10⁶ CFU/m³ for fungal spores, 40,000 to 1.4 x 10⁶ CFU/m³ for bacteria, and up to 2.6 x 10⁴ CFU/m³ for actinomycetes.

If one or more genera of fungi or bacteria are found indoors in concentrations greater than outdoor concentrations, then the source of amplification may need to be found and remediated. When conducting indoor bioaerosol sampling, it is advisable to sample before, during, and after the sampling area is occupied, including times when the heating, ventilating, and air conditioning system is activated and inactivated.

d. Viable and nonviable bioaerosols

Viable microorganisms are metabolically active (living) organisms with the potential to reproduce, grow and colonize. Viruses are not metabolically active but are considered viable if they are capable of reproducing in an appropriate cellular host. Viable microorganisms may be culturable or non-culturable. Culturable organisms reproduce under controlled laboratory conditions. Non-culturable organisms do not reproduce in the laboratory because of intracellular stress or because the conditions (e.g., culture medium or incubation temperature) are not conducive to growth. Some bacteria can be very difficult or impossible to culture from bioaerosols. For example, although human *Mycobacterium tuberculosis* is readily transmitted among people and from people to Guinea pigs, it has never been successfully cultured from an environmental aerosol



sample, probably because of its extremely low airborne concentrations and slow growth rate [Nardell 2016]. Other bioaerosols such as *Histoplasma capsulatum* or *Pneumocystis carinii* may take weeks to grow or may not even grow in culture at all [Dennis 1990; Ibach et al. 1954]. As the name implies, viable bioaerosol sampling involves collecting a bioaerosol and culturing the collected particles. Only culturable microorganisms are enumerated and identified, thus leading to an underestimation of bioaerosol concentration. Non-viable and viable but non-culturable microorganisms are often studied by collecting them with a dry aerosol sampler or a membrane filter. The microorganisms are then enumerated and identified using microscopy, classical microbiology, molecular biology, or immunochemical techniques [Hung et al. 2005; Macher 1999; Reponen et al. 2011b; Tortora et al. 2013].

Assessment of viable bacteria is also dependent on a number of variables including nutrient media, temperature and culture conditions. In indoor environments the collection of viable bacteria may be confounded by endogenous bacterial microflora such as *Staphylococcus epidermis* that sheds with skin flakes [Hung et al. 2005]. Concentrations of viable bacteria have been reported to be as high as 105 CFU/m³ in indoor environments; however, like fungi, the proportion of the total bacterial burden may be higher if non-viable bacteria are also included [Hung et al. 2005]. In addition, viable assessment of several bacterial species of clinical significance may not be the best approach as these bacteria do not remain viable in the air. Alternative methods such as immunoassays or molecular-based methods may provide suitable approaches for quantifying bacterial pathogens.

e. Bioaerosol particle sizes

As noted earlier, the aerodynamic diameter (d_{ac}) of an airborne particle is the most important factor determining how long it will remain in the air, how likely it is to be inhaled, and where it will deposit in the respiratory tract. The sizes of bioaerosol particles can range from tens of nanometers for small fragments to hundreds of micrometers for pollen, fungi or large agglomerations. However, most of the bioaerosol particles of interest in the indoor environment fall between about 100 nm and 10 μm [Nazaroff 2016]. For bacteria, vegetative cells typically have physical diameters of about 0.2 to 2 μm and are 2 to 8 μm in length, while bacterial spores are somewhat smaller [Tortora et al. 2013]. Airborne particles containing bacteria were found to have aerodynamic diameters of about 1 to 3 μm in indoor environments [Gorny et al. 1999; Kujundzic et al. 2006; Meklin et al. 2002]. *Mycobacterium tuberculosis* is a rod-shaped bacteria with a length of about 6.6 μm [Schafer et al. 1999]. When aerosolized from a liquid culture, *M. tuberculosis* DNA was found in particles with aerodynamic diameters of 0.6 to 1.8 μm [Schafer et al. 1999]. Aerosolized *Mycobacterium bovis* BCG (a commonly-used surrogate for *M. tuberculosis*) was found in

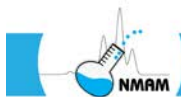

particles with aerodynamic diameters of 0.5 to 9.9 μm [Schafer et al. 1998]. Air sampling around indoor whirlpools in a public facility found airborne mycobacteria DNA in particles with aerodynamic diameters of 0.5 to 9.9 μm [Schafer et al. 2003]. *Actinomyces* spores tend to be smaller, with aerodynamic diameters of cultured spores ranging from 0.6 to 1.5 μm [Madelin and Johnson 1992; Reponen et al. 1998]. Fungal spores have physical diameters of about 0.5 to 30 μm or larger, while the aerodynamic diameters of airborne fungal spores and spore clusters are reported to be from 0.9 to 5 μm [Eduard 2009; Hussein et al. 2013; Reponen et al. 2011b].

Airborne microorganisms are often present as parts of aggregations, droplets or agglomerations that can be much larger than the size of the native microorganism. In indoor environments with large amounts of other aerosol particles like cigarette smoke, bacteria have been found on particles with aerodynamic diameters up to 10 μm , which was larger than airborne bacterial particles in cleaner environments. This was thought to occur because the aerosol particles were forming agglomerates [Gorny et al. 1999]. In a farm study, airborne *Actinomyces* and fungal spores were more likely to be found in aggregates in environments with higher spore concentrations [Karlsson and Malmberg 1989]. In two studies of airborne influenza virus in health care facilities, about half of the airborne virus was found in particles with aerodynamic diameters of 4 μm or greater, even though the virus itself is only about 100 nm in diameter, because the virus was contained in aerosolized droplets of respiratory fluids [Blachere et al. 2009; Lindsley et al. 2010a]. Agglomerates of fungal spores can break apart upon impaction inside an impactor and be collected on subsequent stages with smaller cut-off diameters [Trunov et al. 2001]. Bioaerosols may also be present as cellular fragments that are much smaller than the source microorganisms. Endotoxins are fragments of the cellular walls of Gram-negative bacteria that have been implicated in a variety of illnesses [Eduard et al. 2012; Jacobs 1989; Olenchok 2002]. Fragments of fungal cell walls also are thought to be associated with several types of adverse respiratory health effects [Green et al. 2011; Green et al. 2006b; Olenchok 2002]. Very high levels of fungal fragments have been measured in flood-damaged homes contaminated with mold [Reponen et al. 2007]. Fungal fragments also contain a variety of secondary metabolites, mycotoxins, beta-glucan, antigens and allergens [Green et al. 2011; Green et al. 2006b]. In one study of indoor air in homes, the majority of the endotoxin and fungal wall material was found in particles with aerodynamic diameters of less than 1 μm [Adhikari et al. 2013]. Another study found considerable amounts of endotoxin in aerosol particles from metalworking fluids that were between 0.16 and 0.39 μm [Wang et al. 2007]. Indoor and outdoor measurements of endotoxin levels found that the largest proportion was detected in particles with aerodynamic diameters of less than 1 μm [Kujundzic et al. 2006].

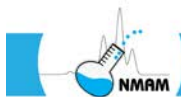

It is common to use an aerosol spectrometer in conjunction with bioaerosol sampling to better understand the size distribution of the airborne particles. One consideration when interpreting the data is, of course, that the large majority of these devices do not distinguish between biological and non-biological aerosols. Another less-obvious factor is that while a few aerosol spectrometers such as the TSI Aerodynamic Particle Sizer measure the aerodynamic diameter of the airborne particles, many aerosol spectrometers measure particles using light scattering and thus provide an approximate physical diameter instead [Hinds 1999; Sorensen et al. 2011]. The difference between the aerodynamic and optical diameters may be significant depending upon the shape and density of the particles.

f. Temperature and humidity

The temperature and humidity of the environment can affect the size of bioaerosol particles, the viability of airborne microorganisms, the growth of microorganisms on surfaces, and the amount of electrostatic charges on aerosols and surfaces. Because of these effects, the environmental temperature and humidity should be recorded during bioaerosol sampling.

Water evaporates rapidly from wet aerosol particles [Hinds 1999]. If an airborne particle is initially an aqueous solution containing non-volatile substances such as salts and organic material, and if the relative humidity is above the crystallization relative humidity (CRH, also called the efflorescence relative humidity), then some of the water will evaporate and the solution will become more concentrated, but the particle will remain liquid. If the relative humidity is below the CRH, then all of the water will evaporate (that is, the particle will desiccate) [Nicas et al. 2005]. Similarly, if an airborne particle is initially a dry combination of salts and organic material, and if the relative humidity is below the deliquescence relative humidity (DRH), then the particle will remain desiccated. However, if the relative humidity is above the DRH, then the particle will absorb water until it liquefies and becomes an aqueous solution. The DRH is always greater than the CRH [Nicas et al. 2005]. A particle in an environment above its CRH (or DRH if it was initially dry) will be larger and heavier and will settle faster than the same particle when the humidity is below the CRH, which can affect the size and amount of bioaerosol particles that are collected during sampling [Mikhailov et al. 2004]. This phenomenon was seen in a study of particles in human exhaled breath, where the particles detected in low humidity air were substantially smaller than those detected when the air was more humid [Holmgren et al. 2011].

Bioaerosol particles may also undergo an increase in size when the humidity increases due to water absorption and swelling of hygroscopic components. An increase in relative humidity has been shown to increase the aerodynamic diameter of fungal spores [Madelin

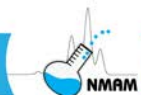

and Johnson 1992; Reponen et al. 1996]. Similar results have been reported for *Actinomyces* spores [Madelin and Johnson 1992].

For airborne viruses, survival decreases as air temperature increases [Ijaz et al. 2016; Tang 2009]. Exposing most viruses to temperatures of 60°C or higher for 60 minutes will inactivate them, although the viruses can be somewhat protected if they are encased in organic material [Tang 2009]. For example, in one set of experiments, airborne particles containing vaccinia virus, influenza virus, and Venezuelan equine encephalomyelitis virus all showed higher survival rates at 7-12°C than at 21-24°C, and still lower survival at 32-34°C [Harper 1961]. Aerosol transmission of influenza virus among Guinea pigs is blocked at air temperatures of 30°C [Lowen et al. 2008]. The effect of humidity on virus survival depends upon the virus; in general, viruses with lipid envelopes tend to survive better at low humidity, while non-enveloped viruses survive better at high humidity [Ijaz et al. 2016; Tang 2009]. For example, influenza viruses and coronaviruses have enveloped capsids, and both survive better at low humidities compared to high [Ijaz et al. 1985a; Ijaz et al. 2016; Noti et al. 2013; Schaffer et al. 1976]. On the other hand, rotaviruses and rhinoviruses have non-enveloped capsids and survive better at high humidities compared to low [Ijaz et al. 1985b; Ijaz et al. 2016; Karim et al. 1985].

The survival of airborne bacteria also decreases as air temperature increases; the survival of virtually all airborne bacteria declines when temperatures are above 24°C [Ijaz et al. 2016; Tang 2009]. However, as with viruses, the effects of humidity on bacterial survival are much more complex, and depend not only upon species but also upon the methods of culture and aerosolization [Cox 1989; Tang 2009]. In field experiments in a greenhouse, survival of certain bacteria was 35- to 65-fold higher at 80% RH than at 40% [Walter et al. 1990]. In laboratory experiments, survival of certain bacteria was virtually complete at low RH but was reduced at RH values above 80% [Cox 1968]. Higher humidities can also significantly decrease the efficacy of ultraviolet germicidal irradiation (UVGI) for reducing levels of viable airborne bacteria [Peccia et al. 2001]. Cox [1987] believes the potential for the movement of the solvent water is an important environmental criterion in assessing survivability of bacteria, viruses, and phages.

Fungi and fungal spores generally are better able to withstand environmental stresses compared to vegetative bacteria and viruses [Ijaz et al. 2016; Tang 2009]. Warm temperatures, wet substrates and humid air conditions favor the growth of fungi on surfaces [Eduard 2009; Tang et al. 2015]. Temperature can induce morphological changes in dimorphic fungi such as the pathogen *Histoplasma capsulatum* [Salvin 1949]. It is not clear, however, how air temperature and humidity affect the viability of airborne fungi and fungal spores [Tang 2009].

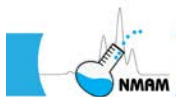

g. Electrostatic effects

Aerosol particles in the workplace can be highly charged, and the electrostatic charge can vary considerably depending upon the aerosol generation mechanism and the particle characteristics [Johnston et al. 1985]. Aerosol particles are especially prone to develop electrostatic charges in low humidity environments [Baron and Deye 1990]. Like most particles, freshly generated microbial aerosols are nearly always electrostatically charged unless steps are taken to neutralize them. Lee et al. [2004b] found that airborne fungi and bacteria carried a net negative charge in most of the laboratory and field environments that they studied. Mainelis et al. [2002] found that a strong positive electrostatic charge reduced the viability of *Pseudomonas fluorescens* bacteria but did not affect *Bacillus subtilis* spores.

The effect of electrostatic charge on aerosol collection is often overlooked, resulting in the possible bias of sampling results [NIOSH 2016a; Vincent 2007]. Aerosol samplers made of non-conductive plastics can develop substantial electrostatic charges, which can degrade their performance significantly [NIOSH 2016a; Baron and Deye 1990]. The use of polyethylene or polytetrafluoroethylene (PTFE) tubing to transport air streams to a sampler can remove a sizeable amount of aerosol particles by electrostatic deposition [Liu et al. 1985]. As noted above, the use of plastic Petri dishes in an Andersen impactor can result in bioaerosol particle losses [Andersen 1958; Kuo 2015]. Whenever possible, it is better to use aerosol samplers made of conductive materials such as metals or specially-treated plastics [NIOSH 2016a].

h. Flow calibration

Accurate airflow rates are very important in calculating the concentration of microorganisms in the air. All samplers should be calibrated before and after sampling to ensure that the flow rate is within the manufacturer's specifications and does not change from the initial calibration. Calibration may be performed using a primary standard such as a spirometer or bubble calibrator. Where it is not possible to calibrate using a primary standard, a calibrated secondary standard such as a dry gas meter may be used. The calibration of such a secondary standard should be traceable to a primary standard. A detailed explanation of the calibration of airflow rates is given by McCammon Jr. and Woebkenberg [NIOSH 2016c].

i. Blanks

Laboratory media blanks are unexposed, fresh samples of media, such as agar plates, filters and impinger fluids. These samples are generally not taken into the field. Before using any batch of media, incubate at least three culture plates under the same conditions as planned



for the field samples, in order to check for sterility of the media. Approximately five media blanks should be included with each sample set. If the samples are to be analyzed by an outside laboratory, consult the specific laboratory procedure for the number of blanks to be submitted. Similarly, blank filters should be processed in the same manner as planned for field samples in order to check for contamination.

Field blanks are simply unopened, fresh media samples that are handled in the same way as field samples, including labeling, except that no air is drawn through the sampler. The generally recommended practice for the number of field blanks is to provide at least two field blanks for every 10 samples with a maximum of 10 field blanks for each sample set.

5 Selection of bioaerosol samplers

The first step in selecting a bioaerosol sampling device is to establish the purpose of the sampling. Once the goal of the bioaerosol sampling is determined, the appropriate sampling methods may be chosen. The selected bioaerosol sampler must be capable of high efficiency particle collection within the physical and biological conditions required by the microorganisms to be sampled. The most appropriate sampling methods will be dictated in part by the techniques that will be used to analyze the sample. Methods for bioaerosol sample analysis are discussed in the next section. A list of some manufacturers and suppliers of bioaerosol sampling equipment and supplies is shown in Appendix I. The characteristics of several commonly used bioaerosol samplers are shown in Appendix II.

a. Sampling for airborne bacteria and fungi

Choosing a bioaerosol sampler for bacteria and fungi begins by deciding how the bioaerosol will be analyzed, and in particular whether the viability of the bacteria or fungi will be evaluated. Culturable bioaerosol sampling instruments must minimize injury during the collection process and maintain the culturability of the collected microorganisms. If the sample will not be cultured, then the samples usually can be collected dry using a membrane filter, cyclone, impactor, or a combination of these. Dry collection is typically simpler and less expensive to perform, and filters and cyclones can handle a wide range of particle concentrations. Organisms that are difficult or impossible to grow in culture are often collected using dry techniques and assessed using polymerase chain reaction (PCR) based methods, which have the advantage of speed and specificity. PCR has been used for rapid detection of *Histoplasma capsulatum* and mycobacteria [Reid and Schafer 1999; Schafer et al. 1999; Schafer et al. 2003]. A DNA-based mold specific quantitative PCR (mqPCR) method is widely used to evaluate indoor fungal bioaerosols in the academic, government and commercial sectors, and is the basis for the Environmental Relative Moldiness Index (ERMI) used to quantify mold contamination in

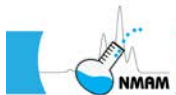

homes [Kettleson et al. 2015; Vesper et al. 2013]. The ERMI and other PCR-based assays are discussed in greater detail later in this chapter.

If viability is to be studied, then the samples usually will need to be collected with an impinger or in an Andersen impactor loaded with agar plates, because many microorganisms will lose viability due to damage or desiccation if collected dry [Cox 1987; Hung et al. 2005]. For example, a membrane filter sampler is not appropriate for sampling culturable *Escherichia coli* because the cells desiccate and become either nonviable or viable but not culturable under these conditions [Jensen et al. 1992]. Similar results have been reported for other bacteria and fungi [Macher and First 1984; Wang et al. 2001]. Depending upon the target microorganism, impingers may be filled with distilled water or a buffered isotonic solution, sometimes with antifoaming agents to reduce foaming and proteins to enhance survival. Mineral oil has also been used in impingers instead of aqueous solutions to avoid evaporation [Lin et al. 2000]. Impactors are loaded with agar plates; the choice of agar depends upon the microorganisms of interest and the desired selectivity (discussed in the next section).

As noted previously, depending upon the investigation that is being conducted, the particle size distribution of the bioaerosol may be very important in the evaluation of the data obtained. If particle size information is needed to, for example, determine how much of the bioaerosol is in the respirable size fraction, then a size-selective sampler should be used for at least some of the collections if possible. For example, if an SAS-Compact sampler was the selected sampler for collection of culturable *Escherichia coli*, an Andersen 6-Stage sampler could be used to determine the particle size distribution at each location sampled. The expected size of the bioaerosol particles is also an important factor in choosing a sampler. For example, an impactor with a d_{50} of 4 μm should not be used to collect *Aspergillus niger* spores (dae 1-3 μm) because most spores would remain entrained in the air and pass through the instrument.

NIOSH Method 0800 discusses sampling for culturable airborne bacteria and fungi with an Andersen cascade impactor [NIOSH 2003b]. Standard methods for the collection of airborne fungi by inertial impaction are presented in ASTM Standards D7788 [ASTM 2009; ASTM 2014d]. ASTM Standard D7391 also discusses the aspects related to the laboratory analysis.

b. Sampling for airborne viruses

Airborne viruses are more difficult to study in bioaerosols than bacteria and fungi for a variety of reasons [Prussin et al. 2014; Verreault et al. 2008]. Viruses are more difficult to culture because they are obligatory intracellular parasites that require a host cell for

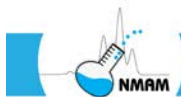

reproduction [Tortora et al. 2013]. Bioaerosols of pathogenic viruses have been found in many settings to be present in low concentrations that can be difficult to detect [Blachere et al. 2009; Bonifait et al. 2015; Lindsley et al. 2010a; Tseng et al. 2010; Yang et al. 2011]. Viruses also are generally more susceptible to damage during aerosol collection than are bacteria or fungi, although their sensitivity varies widely with the collection method and species [Appert et al. 2012; Turgeon et al. 2014; Zuo et al. 2013]. Aerosol sampling methods for viruses have been reviewed by Verreault et al. [2008].

Bacteriophages are viruses that infect bacteria rather than multicellular organisms. They are used in laboratory aerosol studies as tracers for aerosol particles and as surrogates for airborne viruses that infect humans [Fisher et al. 2012; Tseng and Li 2005; Turgeon et al. 2014]. Bacteriophages are not known to be hazardous to humans but are of interest to industries that rely on bacteria such as cheese manufacturers [Verreault et al. 2011]. Polymerase chain reaction (PCR) based methods are often used to study viral bioaerosols. PCR has the advantages of being very sensitive and very specific, and considerably easier to perform than viral cultural assays. For this reason, most recent field studies of airborne viruses have used PCR as the detection method. Examples include studies of viruses in healthcare facilities [Blachere et al. 2009; Booth et al. 2005; Lindsley et al. 2010a; Thompson et al. 2013; Tseng et al. 2010], influenza at poultry and pig farms [Corzo et al. 2013; Jonges et al. 2015], airborne viruses in a sewage treatment plant [Masclaux et al. 2014], and respiratory viruses in human coughs and exhaled breath [Gralton et al. 2013; Lindsley et al. 2010b; Milton et al. 2013].

PCR has both the advantage and disadvantage of not requiring that the virus be viable in order to be detected. This eliminates the need to preserve viability during and after collection and allows the use of dry collection methods such as cyclone samplers, dry impactors and filters, which are simpler and easier to carry out. On the other hand, this also means that it is unclear whether the airborne virus is infectious or not, which makes interpretation of data more difficult. This is a common criticism of PCR-based bioaerosol studies.

If the virus in a bioaerosol sample is to be cultured, in most cases the sample will need to be collected into an aqueous media using an impinger or wetted surface aerosol collector. Fabian et al. [2009] showed that collecting airborne influenza virus in aqueous media using an SKC BioSampler preserved infectivity much better than dry collection using filters or an impactor. A less-common method is to collect viable viruses using an Andersen impactor. Gustin et al. [2011] collected airborne influenza virus using an Andersen impactor by placing a filter and a thin layer of gelatin on top of the agar in the culture plates. After collection, the gelatin was removed and melted at 37°C to allow

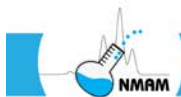

subsequent culture of the virus. Note that the collection media must be compatible with the cell culture system used to host the virus.

6 Sample preparation for culturable bioaerosols

Collecting and culturing viable airborne microorganisms is the most common technique used by industrial hygienists to assess bioaerosols [Macher 1999]. However, the appropriate sample preparation method is highly dependent upon the microorganism(s) of interest, sample source, and down-stream analysis. These sampling approaches are further confounded as viable bioaerosols have been estimated to account for approximately 1% of the total bioaerosol load, and non-viable bioaerosols are often overlooked [Hung et al. 2005]. In contrast, non-culturable bacteria and fungi cannot be grown in conventional lab-based conditions, but their presence is still important from a health perspective [Green et al. 2011; Mitakakis et al. 2003]. Non-viable bioaerosols can be determined through other detection methodologies such as microscopy, proteomic, immunological, and molecular analysis methods, and some of these approaches are discussed in section 9. A list of the common bioaerosols encountered in indoor and outdoor environments, as well as the fungi that are common contaminants of indoor building materials, can be found in Flannigan et al. [2011].

a. Sample preparation for bacteria and fungi

Viable bacterial and fungal bioaerosol identification is made through the collection, deposition, and growth of a viable propagule or intact cell on a selected nutrient agar medium contained in a sterile petri dish or liquid culture suspension [Macher 1999]. These methods are similar for both fungal and bacterial bioaerosols [Flannigan et al. 2011; Hung et al. 2005]. Selection of the nutrient media, incubation conditions (time and temperature), and potential damage to the culturable bioaerosol during sampling are among several critical variables to review before the collection, growth and proliferation of a viable propagule [Eduard et al. 2012; Hung et al. 2005; Macher 1999]. These parameters have been reviewed elsewhere, but should be taken into consideration when planning an environmental survey [Hung et al. 2005; Macher 1999].

Growth media can be defined as either broad or selective [Macher 1999]. As the term implies, broad nutrient media supports the growth of a diverse number of microorganisms. In contrast, a selective growth medium, with appropriate energy sources, nutrients, and pH, is used to enrich growth of the specific microorganism in question and inhibit the growth of competitive organisms [Macher 1999]. A variety of broad and selective nutrient media for bacteria and fungi are available to the industrial hygienist and can be found in Hung et al. [2005] and Macher [1999].

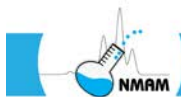

Following sample collection, liquid or agar cultures are incubated at a suitable temperature and atmosphere (facultative versus aerobic) for an appropriate time. Fast-growing bacteria may develop microcolonies in hours, while fungi may take days to develop into a visible colony and perhaps sporulate. Organisms such as *Mycobacterium tuberculosis* or the dimorphic fungal pathogens, *Histoplasma capsulatum* or *Blastomyces dermatitidis* may require weeks of incubation to produce visible colonies [ATS 1990; Babady et al. 2011]. For fungi, plates are typically incubated at room temperature (18°C-25°C) or, if it is a clinically relevant isolate, at 35°C [ACGIH 1989; Baron and Finegold 1990; Hung et al. 2005; Macher 1999]. In contrast, environmental bacteria are grown between 18°C and 28°C, while thermophilic bacteria are grown between 50°C and 58°C [Hung et al. 2005; Macher 1999].

After allowing for vegetative growth of all viable propagules on the selected nutrient medium, the number of colonies is identified, quantified and presented as colony forming units (CFUs) [Eduard et al. 2012]. Media blanks (laboratory and field) should be processed using the same methods as samples to control for environmental or laboratory contaminants. A collection of bioaerosol identification manuals is presented in both the AIHA and ACGIH manuals [Hung et al. 2005; Macher 1999]. Color micrographs of common fungal contaminants are also presented in Flannigan et al. [2011]. Along with the quantification of viable microorganisms, taxonomic data and an interpretation of the datasets are generally reported [Hung et al. 2005].

The interest in detecting and quantifying fungi has increased following consensus documents that reported associations between fungi in damp indoor environments and adverse respiratory health effects [IOM 2004; Mendell et al. 2011; WHO 2009]. Compared to bacteria, additional variables need to be taken into consideration by the industrial hygienist when evaluating viable fungal bioaerosols including water activity, colony competition, and carbohydrate nutrient sources [Hung et al. 2005; Macher 1999]. Broad viable culture approaches favor species belonging to the phylum Ascomycota, as well as species that outcompete slower-growing species. Several different types of media and physiological conditions (e.g. temperature) may also need to be employed to assess complete fungal diversity using this approach. For fungi, selection of the nutrient media may potentially bias the growth of specific viable fungal bioaerosols. Common nutrient media include malt extract agar (MEA) supplemented with chloramphenicol or rose bengal agar to suppress bacterial growth [Hung et al. 2005; Macher 1999]. Cellulose agar can also be used for the selection of indoor fungal contaminants such as *Stachybotrys chartarum* [Hung et al. 2005]. Dichloran glycerol (DG18) can be used to select for those fungi that are xerotolerant [Flannigan et al. 2011; Hocking and Pitt 1980; Macher 1999]. Temperature and incubation time can also be used to select for specific fungal bioaerosols such as *Aspergillus fumigatus* which are capable of growth within human hosts [Flannigan

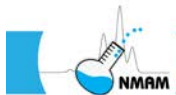

et al. 2011; Hung et al. 2005]. A selection of nutrient media and growth conditions that can be used for viable fungal culture can be found in Hung et al. [2005], Flannigan et al. [2011] and Macher [1999].

b. Sample preparation for viruses

Because viruses are obligate intracellular parasites, special precautions must be taken in an effort to minimize damage to the collected virus-laden aerosol. Environmental factors such as humidity, temperature and gas composition of the air can significantly impact the infectiousness of a virion and should be monitored closely [Ijaz et al. 2016]. Several studies have shown that the inactivation of an airborne virus is directly related to the relative humidity and temperature [Weber and Stilianakis 2008]. In one study, high humidity levels caused a loss of infectious influenza virus from simulated coughs [Noti et al. 2013]. Similarly, using a ferret animal model, Lowen et al. [2007] demonstrated a correlation between airborne transmission of influenza and the relative humidity and temperature. Through the use of an ozone-oxygen delivery system, researchers were able to show that ozone-mediated reactive oxygen species (ROS) caused lipid peroxidation and subsequent damage to the lipid envelope and viral capsid [Murray et al. 2008]. Such studies highlight the importance of collecting viral aerosols under optimal environmental conditions and, when possible, minimizing the detrimental effects of environmental factors on collected samples.

Air sampling techniques also may cause damage to the virus and compromise analysis. Before collecting viral aerosols, the hardiness of the target virus must be taken into account. Currently, there are over 200 known respiratory viruses that fall under one family of DNA viruses (Adenoviridae) and four families of RNA viruses (Orthomyxoviridae, Paramyxoviridae, Picornaviridae and Coronaviridae) [Abed and Boivin 2006]. While all viruses package their genome in a protective protein coat known as the capsid, some viruses also possess a lipid bilayer envelope that, as the name implies, surrounds the viral capsid. Once outside the host, the viral envelope is highly sensitive to desiccation, temperature fluctuations and readily undergoes degradation. Variations in temperature can greatly affect viral enzymatic activity and nucleic acid stability [Tang 2009]. As noted earlier, viruses with lipid envelopes tend to survive better at low humidity, while non-enveloped viruses survive better at high humidity [Tang 2009]. Also, RNA viruses are inherently more unstable than DNA viruses due to the presence of the 2'-hydroxyl group on the ribose sugar molecule of RNA that is susceptible to base-catalyzed hydrolysis and degradation. Therefore it is critical that collection methods do not disrupt the lipid membrane and/or compromise the integrity of nucleic acids. Impairment of either the lipid envelope or nucleic acids can significantly impact detection of the viral aerosol and lead to false negatives.



To optimize collection efficiency while maintaining infectiousness of the viral aerosol, researchers must be discriminating when deciding on what type of aerosol sampler to use and how long the sampling collection period should be. As discussed in Section 3, some commercially available bioaerosol sampling devices exist, each of which possesses unique collection properties. In a review by Verreault et al. [2008], liquid impingers were found to be the most effective sampling devices for capturing small viral particles while maintaining virion integrity and infectiousness [Verreault et al. 2008].

While liquid impingement preserves and maintains viral integrity (in comparison to dry impaction), the type of collection medium must also be considered. With culture-based identification methods, it is of utmost importance to maintain the stability of the collected viruses while using cell-culture compatible media. The type of liquid medium, as well as the volume used, are important variables to consider. Virus collection and transport media are typically isotonic solutions with a buffer to control the pH, protein to protect the virus, and antibiotics to prevent microbial growth. If used in an impinger, the viral collection media may also include an antifoaming agent. Specimen handling, storage time and storage temperature can significantly impact the integrity of sample analysis. Collection and storage under suboptimal conditions can result in viral inactivation and degradation of nucleic acids. Bioaerosol samples containing viruses should be processed as soon as possible after collection. They should be refrigerated or frozen and transported as quickly as possible. The stability and retention of viability depend upon the virus [Johnson 1990].

7 Identification of culturable bioaerosols

Identification of the microbial taxa is a critical element in the determination of the viable bioaerosol load in an industrial or occupational environment. The science of classification, especially the classification of living forms, is called taxonomy. The objective of taxonomy is to classify living organisms to establish the relationship between one group of organisms and another, and to differentiate between them based on phenotypic and genotypic characteristics. The identification of viable fungal bioaerosols has been challenging due to the confusion of current nomenclature [Flannigan et al. 2011]. As a result, investigators often use synonymous names that over time have been placed in another group. Familiarity with taxonomy and nomenclature is critical when undertaking assessments of the viable microbial burden in an environment [Flannigan et al. 2011]. Several criteria and methods for the classification of culturable microorganisms are briefly discussed in the following subsections. Besides using these methods, the nonviable and non-culturable methods of identification discussed in Section 9 may also be used in combination with these viable methods.

Classical microbiology includes general methods for classifying or identifying microorganisms. The least specific of these is the observation of growth characteristics.



Growth characteristics include the appearance of the microorganisms in a liquid medium, colony morphology on solid medium, pigmentation, and arrangement of reproductive structures such as fungal sexual or asexual spores.

a. Bacteria

Bacteria are prokaryotes with distinguishing morphological characteristics that include the cell shape, cell size, arrangement of cells, and the presence or absence of flagella, capsules, or endospores. Simple and differential staining may be performed on bacteria to enhance visualization and to aid in grouping and identification [Tortora et al. 2013]. In simple staining, a single basic dye is used that highlights the cellular morphology. Stains such as methylene blue, carbolfuchsin, crystal violet, or safranin may be used for bacteria.

A differential stain distinguishes among structures or microorganisms based on varying reactions to the staining procedure. Two examples of differential stains are the Gram stain and the acid-fast stain. In Gram staining, bacteria are stained and then washed with alcohol. Gram-positive bacteria possess a cell wall composed of a relatively thick peptidoglycan layer and teichoic acids, which retains the dye complex. Gram-negative bacteria possess a cell wall composed of a thin peptidoglycan layer and an outer membrane which consists of lipoproteins, lipopolysaccharides, and phospholipids, and do not retain the dye complex when washed [Tortora et al. 2013]. A few of the commercially available identification kits require a Gram-stain prescreening to assure that the correct reagents are used. Acid-fast stains are used for some species of bacteria, particularly those of the genus *Mycobacterium*, which do not stain readily. In the acid-fast staining process, the application of heat facilitates the staining of the microorganism [Tortora et al. 2013].

b. Legionella

Bacteria that are placed in the genus *Legionella*, are the etiological agents of pulmonary infections called Legionellosis [Fields 2002]. *Legionella pneumophila* (Figure 1B) is the most widely known species that has been implicated in Legionnaires' disease, which can result in pneumonia. Milder illness with fever and body aches is referred to as Pontiac fever. Bacteria placed in this genus consist of Gram negative rods and are associated with freshwater in the environment [ASTM 2015; Macher 1999]. Exposure to warm temperatures (25-42°C) can result in the growth and proliferation of the bacteria, a problem that has emerged in water and air handling systems within the indoor built environment [Hung et al. 2005]. Growth and persistence within Protista have also been reported [Hung et al. 2005]. For health care facilities, ASHRAE Guideline 12-2000 recommends storing and distributing cold water at <20°C (68°F), whereas hot water should be stored at >60°C (140°F) and circulated with a minimum return temperature of 51°C (124°F). In other settings, hot water should be stored at ≥40°C (≥120°F) [ASHRAE

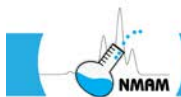

2000]. Building air conditioning cooling towers, humidifiers, or structures used for bathing such as hot tubs are particularly susceptible to *Legionella* amplification. *Legionella* can be aerosolized within water droplets via abiotic disturbance mechanisms and disseminated into the breathing zone of the subject. Airborne levels lower than 10 CFU/mL have been associated with Legionnaires' disease [ASTM 2015; Demirjian et al. 2015; Hung et al. 2005].

Since the identification of *L. pneumophila* and association with Legionnaires' disease in 1976, there have been many studies that have focused on a variety of approaches to detect and mitigate this bacterial species from the built environment. These approaches are broadly reviewed in Hung et al. [2005]. Along with industrial hygiene practices and building maintenance, environmental monitoring and surveillance programs are critical to ensure effectiveness of employed engineering controls and maintenance/disinfection programs [ASTM 2015]. ASTM International has published a standard for inspecting water systems and investigating outbreaks [ASTM 2015]. The CDC has also published a sampling procedure [CDC 2015].

In 2015, ASHRAE published a consensus standard for the primary prevention of Legionnaires' disease in building water systems [ASHRAE 2015]. Similar environmental assessment methods are utilized in maintenance programs and outbreak cases. In this approach, bulk water samples are typically collected (250 mL to 1 L for non-potable and 1000 mL for potable water), concentrated via filtration, resuspended, and then plated on a growth medium (such as buffered charcoal yeast extract media) to enable the propagation and identification of *Legionella spp.* [CDC 2015]. Samples may also be direct plated, acid treated, or heat treated to enhance the recovery of the bacterium. Colonies represent the viable fraction of *Legionella* in a water sample and these colonies are quantified and reported as CFU/mL

In addition to viable culture-based approaches, molecular-based methods such as PCR as well as antibody-based methods have been developed to enable the detection of *Legionella*. Air sampling is not considered a reliable method for *Legionella* surveillance in the built environment [Hung et al. 2005].



Using an environmental microbiology laboratory with expertise in propagating *Legionella* spp. is important when evaluating Legionella contamination of water systems within the built environment. A number of laboratories participate in the CDC's Environmental *Legionella* Isolation Techniques Evaluation (ELITE) Program. Participation in the program is voluntary and enables laboratories to test their proficiency in *Legionella* isolation and identification techniques against standardized samples. A list of ELITE member laboratories can be accessed at <https://wwwn.cdc.gov/elite/Public/MemberList.aspx>.

c. Fungi

In general, culturable fungi are classified by colony features including the septation of hyphae and colony morphological phenotypes, including pigmentation and the presentation of asexual and sexual spores on hyphae. Stains such as Calberla's solution, lactophenol cotton blue, periodic acid-Schiff stain, Grocott's methenamine silver stain, and calcofluor white may be used in combination with potassium hydroxide (10% KOH) to resolve these colony structures using microscopic-based approaches [Hung et al. 2005]. The identification and classification of fungal colonies should be performed by an examiner that is skilled in microbiology and mycology. A number of commercial labs that employ examiners skilled in the identification of microorganisms encountered in indoor and occupational environments are accredited by the AIHA Environmental Microbiology Laboratory Accreditation Program (EMLAP).

In addition to viable culture-based approaches, biochemical, physiological, and nutritional tests for bacteria and fungi can be used [Flannigan et al. 2011]. These testing strategies offer identification based on numerous variables including cell wall constituents, pigment biochemicals, storage inclusions, antigens, optimum temperature and temperature range, the effect of oxygen on growth, pH tolerance, osmotic tolerance, salt requirement and tolerance, antibiotic sensitivity, energy sources, carbon sources, nitrogen sources, fermentation products, and modes of metabolism (autotrophic, heterotrophic, fermentative, respiratory). As a rule, batteries of such tests, rather than any one individual test, are used to identify or classify microorganisms. A few commercially available test batteries are discussed briefly in the section on biochemical approaches.



8 Enumeration of culturable bioaerosols

a. Enumeration of bacteria and fungi

The total concentration of culturable airborne microorganisms in a sample is determined by collecting the bioaerosol sample on a culture plate or plates (or inoculating culture plates with a bioaerosol sample), incubating the plates, and dividing the number of colonies observed on the culture plates by the volume of air sampled. Note that, as discussed in section 2, the number of colonies counted on an agar plate from a bioaerosol impactor must be adjusted using a positive-hole correction factor to correct for multiple microorganisms depositing beneath an impactor hole [Andersen 1958; Leopold 1988; Macher 1989]. A colony is defined as a macroscopically visible growth of microorganisms on a solid nutrient medium. Concentrations of culturable bioaerosols collected during air sampling are normally reported as colony forming units (CFU) per unit volume of air [Eduard et al. 2012]. CFUs also can be determined from samples collected in a swab or dust sample collected from the floor or area of contamination [Hung et al. 2005]. Often, it is difficult to identify multiple colonies at one location on a plate because of the lack of differential colony morphology [Burge et al. 1977]. In addition, some organisms produce large, spreading colonies while others produce microcolonies. Analysis of plates containing multiple types of microorganisms can be difficult because the chemicals secreted by one microorganism might inhibit the growth of other microorganisms at that same location [Burge et al. 1977]. The morphology of the colony of one microorganism also may completely obscure that of another, and a fast-grower might obscure a slow-grower.

b. Enumeration of viruses

Before the advent and mainstreaming of molecular-based detection methodologies, cell culture-based methods and serological assays were considered the gold standard for the detection of viral pathogens. Typically, through the use of commercially available immortal cell lines, researchers can screen collected bioaerosols by inoculating cells and looking for common cytopathic effects (CPEs) such as rounding of infected cells, fusion with adjacent cells and lysis of cells. Examples of well-known cell lines that are routinely used in viral diagnostics include primary rhesus monkey kidney (RhMK) cells, primary rabbit kidney cells, human lung fibroblasts (MRC-5), human epidermoid carcinoma cells (HEp-2), human lung carcinoma cells (A549) and Madin Darby kidney cells (MDCK) [Leland and Ginocchio 2007]. Selection of the appropriate cell line is based on the specimen source and the suspected causal viral pathogen. Certain viral pathogens may require several cell passages before CPEs can be observed. More information on enumeration assays for viable viruses can be found in standard virology reference texts, such Principles of Virology [Flint et al. 2009b] and Fields Virology [Fields et al. 2007].

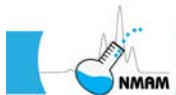

1.) **Viral plaque assay**

A widely used approach for detecting viral pathogens and quantifying viral titers is the viral plaque assay (VPA) [Condit 2007]. Under biological safety controls, the appropriate cell line is propagated and plated, usually in a 6-well format, at a concentration at which cells form a monolayer. The cell monolayer is next treated for a defined period (30-60 minutes) with a specific volume (0.1 mL to 1.5 mL) of the collected bioaerosol and incubated at the specified temperature and CO₂ levels for 24 to 72 hours. Throughout the incubation period, cells are routinely inspected and CPEs are documented. Upon completion of the incubation period, cells are chemically fixed, stained and plaques (zones of cellular clearing) are enumerated. The final concentration of the collected viral aerosols is calculated based on the number of plaques, dilution of the inoculum and volume plated, and is expressed in plaque forming units per mL (PFU/mL). While the VPA is a cost-effective method of assessing sample viral loads, results can take anywhere from 3-5 days. Other limitations such as the inability to detect low viral titers and inactivated (noninfectious) virus and the failure of some viruses to form plaques, may compromise detection and underestimate the viral loads in an aerosol sample. Likewise, common indoor and outdoor contaminants (such as fungi and bacteria) can impair the VPA by disrupting the cellular monolayer or outcompeting for nutrients in the cell culture medium.

2.) **Tissue culture infectious dose assay**

Another cell culture-based approach to identifying viral aerosols is the Tissue Culture Infectious Dose assay (TCID₅₀), also known as an endpoint dilution assay [Condit 2007]. As with the VPA, select cells are plated at a desired concentration in a 96-well format and inoculated with serial dilutions of the collected sample. Following a specified incubation period, cells are examined for CPEs. The TCID₅₀ is defined as the dilution of virus required to infect 50% of the cell culture wells [Reed and Muench 1938]. Based on the number of cells that are infected at the designated virus dilution, viral titers are mathematically calculated. Limitations of the TCID₅₀ are similar to those observed with the VPA.

3.) **Immunofluorescence antibody (IFA) assays**

To enhance viral detection and quantify viral loads, immunofluorescence antibody (IFA) assays (direct or indirect) are frequently used in combination with cell culture-based methods [Flint et al. 2009a; Tortora et al. 2013]. By combining infected cells with a fluorescently-labeled, antigen-specific antibody, it is possible to increase detection levels without the lengthy incubation periods that are typically necessary with VPAs and TCID₅₀ assays.



c. Interpretation of data

In industrial hygiene surveys that evaluate bioaerosols, indoor bioaerosol levels are usually compared to outdoor levels or to a control area. In general, indoor bioaerosol levels are lower than outdoor levels, and the taxa are similar [ACGIH 1989; Burge et al. 1977; Hung et al. 2005; Macher 1999; Solomon et al. 1980]. However, elevated indoor bioaerosol levels may be a sign of dampness, water infiltration, or microbial contamination [Hung et al. 2005]. In 2010, The ACGIH published a variety of occupational exposure limits for aerosols that are derived from biological material in specific industries and include subtilisins derived from *Bacillus subtilis*, as well as cotton, grain, flour, wood, and organic dusts [ACGIH 2015; Eduard et al. 2012]. To date, no occupational exposure limits for specific fungal bioaerosols exist and these typically fall under particulate matter not otherwise regulated (10 mg/m³ for inhalable dust; [ACGIH 2015; Eduard et al. 2012]. Proposed limits developed in other regions of the world are provided in Eduard et al. [2012].

Although the quantification of viable fungal propagules can provide helpful datasets to evaluate differences between indoor and outdoor fungal diversity, the interpretation of results should be evaluated closely. Total fungal exposure will be underestimated as non-viable fungal bioaerosols are not captured in the analysis [Eduard et al. 2012]. Fungal genera, including *Cladosporium*, *Alternaria*, and *Epicoccum*, and Basidiomycetes are predominantly localized in outdoor environments and the presence of elevated concentrations may be an indicator of indoor fungal contamination [Hung et al. 2005]. Similarly, the presence of certain hydrophilic species including *Stachybotrys chartarum* and *Aspergillus versicolor*, and *Chaetomium globosum* may be signs of indoor fungal contamination and may require immediate inspection [Flannigan et al. 2011; Hung et al. 2005].

Where local amplification and dissemination of bacteria have not occurred in an occupied, indoor environment, Gram-positive cocci (e.g., *Micrococcus* and *Staphylococcus*) are normally dominant [Morey et al. 1986]. Airborne human skin scales and respiratory secretions may contain Gram-positive cocci [ACGIH 1989; Hung et al. 2005]. Detection of high levels of these microorganisms may be an indication of over-crowding and inadequate ventilation. Indoor air that tests high for Gram-negative bacteria indicates a need to identify and eliminate the source of contamination. Concentrations ranging from 4,500-10,000 CFU/m³ have been suggested as the upper limit for ubiquitous bacterial aerosols [ACGIH 1989; Nevalainen 1989]. These exposure limits, however, do not apply to pathogenic microorganisms. Actinomycetes (mesophilic and thermophilic) are commonly found in agricultural areas. Their presence in indoor environments is an indicator of contamination [ACGIH 1989; Banaszak et al. 1970; Lacey and Crook 1988]. Thermophilic

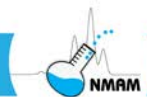

Actinomycetes at concentrations above 70 CFU/m³ in an affected person's work area have been regarded as the threshold for triggering remedial action [Otten et al. 1986].

9 Sample analysis methods for non-viable and non-culturable bioaerosols

The collection and classification of nonviable and non-culturable microorganisms cannot be performed by using viable culture methods. A large proportion of fungal bioaerosols are non-viable and would not grow and proliferate on nutrient media [Eduard et al. 2012]. This fraction of the bioaerosol load is equally important to assess in industrial hygiene surveys that investigate the role of personal bioaerosol exposure on respiratory health [Brasel et al. 2005; Green et al. 2011; Mitakakis et al. 2003]. These bioaerosols can also contain antigens, allergens, microbial volatile organic compounds and even mycotoxins [Brasel et al. 2005; Eduard et al. 2012; Green et al. 2011; Green et al. 2006b]. Identification of nonviable or non-culturable microorganisms or components of microorganisms (such as cell wall fragments) can be performed using a variety of other available assessment strategies such as microscopy, immunoassays and, more recently, molecular biology techniques [Afanou et al. 2015; Brasel et al. 2005; Eduard et al. 2012; Flannigan et al. 2011; Green et al. 2011; Hung et al. 2005; Macher 1999; Rittenour et al. 2012].

Microscopy includes a variety of approaches that utilize bright-field, light, phase contrast, fluorescence or even electron-based approaches [Eduard et al. 2012; Macher 1999]. These methods enable the enumeration of both viable and nonviable microorganisms [Macher 1999] as well as other non-culturable bioaerosols including cell wall fragments, plant pollen and pteridophyte and bryophyte spores [Green et al. 2011; Rittenour et al. 2012]. These approaches provide a platform to visualize particle morphology and to identify reproductive fungal structures of individual genera that are based on a combination of propagule phenotypes [Flannigan et al. 2011; Macher 1999]. However, these approaches can be confounded by observer bias, especially when it comes to differentiating bioaerosols that contain similar morphological phenotypes such as asexual spores (e.g. *Aspergillus conidia*) [Flannigan et al. 2011; Hung et al. 2005]. The ASTM has published a standard method for the use of optical microscopy to categorize and quantify fungal structures in samples collected by inertial impaction [ASTM 2009].

To overcome these methodological challenges, alternative methods based on the quantification of bioaerosol biomarkers (proteins or DNA) have been developed that enable the quantification of these bioaerosol sources [Eduard et al. 2012]. These include a variety of assessment methods that can be used to qualitatively and quantitatively assess bioaerosol exposure by detecting cell wall components, proteins, carbohydrates, or oligonucleotides (e.g.



endotoxin or β -glucan) [Eduard et al. 2012]. Other chemical and proteomic methods including HPLC, flow cytometry, and mass spectrometry-based approaches can also be used to detect and quantify cell wall components such as microbial volatile organic compounds and mycotoxins. These approaches have been reviewed more extensively by Flannigan et al. [2011].

Several modifications of classical biochemical procedures have been used in recent years to facilitate inoculation of media, decrease the incubation time, automate the procedure, and systematize the determination of species based on reaction patterns. Historically, clinical microbiological techniques have been used for analysis of environmental samples. However, clinical strains and environmental isolates may differ, requiring modification of clinically-based techniques.

a. Microscopy

1.) Bright-field or light

In bright-field or light microscopy, an ordinary microscope is used for the morphological observation and sizing of sampled bioaerosols. Visible light from an incandescent source is used for illumination and the specimen appears against a bright backfield. Objects smaller than 0.2 μm cannot be resolved. The image contrast (visibility) decreases as the refractive index of the substance/microorganism under observation and the mounting medium become similar. To maximize the contrast, the mounting medium should have the same refractive index as glass or the immersion oil. Membrane filters are often "cleared" by using the appropriate immersion oil or acetone vapor/triacetin combination. This method is commonly used to observe various stained specimens and to identify and count viable and non-viable bioaerosols. In addition, pollen grains are often identified and enumerated in this manner [Eduard et al. 1990].

Collection of fungal bioaerosols onto an adhesive surface followed by microscopic identification based on the morphological characteristics of the spores (size, shape, septation etc.) is another common method of assessment. This non-viable method overcomes limitations introduced in viable analyses and many genera can be differentiated based on differences in spore morphology [Eduard et al. 2012; Macher 1999]. Microscopic examination of fungi captured on filters or an adhesive tape are divided into seven spore morphological characteristics and include amero-, didymo-, helico-, stauro-, dictyo-, phragmo-, and scoleco- spores [Kendrick 2000]. Amerospores are the most common spore morphology encountered in air samples and are the most challenging to differentiate taxonomically [Kendrick 2000]. Amerospores are usually placed in a group represented as *Aspergillus/Penicillium* group [Hung et al. 2005].

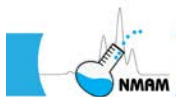

Many other common environmental fungal bioaerosols share similar morphologies which can make taxonomic placement challenging for the untrained or inexperienced observer [Eduard et al. 2012]. Typical magnification used in the assessment of fungal propagules ranges from 400-1000X. A standard operating procedure for the assessment of microscopic non-viable samples is presented in Hung et al. [2005] and by ASTM [2009].

The confounding factors associated with traditional fungal exposure assessment methods have limited our understanding of the spectrum of fungal bioaerosols in industrial and occupational environments. Measures using these approaches also cannot be acquired in real time. Furthermore, identifying and quantifying the complete diversity of fungal bioaerosols using a standardized methodology is critical in the determination of fungal bioaerosols within occupational environments [ASTM 2009; Hung et al. 2005].

2.) **Phase contrast**

Phase-contrast microscopy is used when the microorganism under observation (e.g., *Escherichia coli*) is hyaline and an alternative mounting medium is not possible. As light passes through the specimen, variations in the index of refraction of the components cause phase shifts in the light. A phase-contrast microscope uses a special condenser and diffraction plate that cause these phase shifts to appear as differences in brightness and contrast. One cannot see an object exactly matching the refractive index of the mounting liquid; however, very slight differences produce visible images. This type of microscope is commonly used to provide detailed examination of the internal structures of living specimens; no staining is required.

3.) **Fluorescence**

Fluorescence microscopy uses an ultraviolet or near-ultraviolet source of illumination that causes fluorescent compounds in a specimen to emit light. Fluorescence microscopy for the direct count of microorganisms has been described in a number of studies [Eduard et al. 2012]. Direct-count methods to enumerate microorganisms (especially bacteria) have been developed using fluorescence microscopy and some stains such as acridine orange, fluorescein isothiocyanate (FITC) and 4',6-diamidino-2-phenyl-indole (DAPI) [Macher 1999; Thermo Fisher Scientific 2014]. Utilization of stains such as calcofluor white can resolve fungal spores and hyphal structures [Haghani et al. 2013]. This stain binds to chitin; however, other plant-derived and insect bioaerosol sources (e.g. dust mite, plant pollen) may also be resolved using this stain. Viability stains also have been developed and are available commercially for the detection of viable fungi and bacteria bioaerosols in collected air samples [Thermo Fisher Scientific 2014].

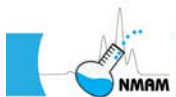

4.) **Electron**

Electron microscopy consists of a beam of electrons that enable structures smaller than 0.2 μm , such as viruses, to be resolved. Scanning electron microscopy (SEM) and, more recently, field emission scanning electron microscopy (FESEM), are approaches used to study the surface features of prokaryote and eukaryote cells as well as viruses (usually magnified 1,000-10,000X). These bioaerosols are immobilized onto a semi-solid filter submicron membrane or in the form of a liquid suspension and a three-dimensional image of the area is generated. Images from SEM can provide vital information about the size, morphology and concentration of the collected bioaerosol [Afanou et al. 2014; Eduard et al. 2012]. However, SEM does not provide information on viability of the collected bioaerosol. FESEM has been recently used to resolve fungal fragments that are produced from fungal colonies following abiotic disturbance [Afanou et al. 2015; Afanou et al. 2014]. Transmission electron microscopy can also be used to examine viruses or the internal ultrastructure in thin sections of cells (usually magnified 10,000-100,000X), although the image produced is not three-dimensional. Compared to other methods of assessment described in this chapter, SEM and FESEM-based approaches require a highly trained technician to obtain images from bioaerosols captured on filter membranes.

b. Endotoxin assays

The lipopolysaccharide endotoxin is a virulence factor possessed by all Enterobacteriaceae (as well as other Gram-negative bacteria) that is found in the outer membrane of the cell wall. Airborne endotoxin has been found in high concentrations in agricultural, industrial, and office environments [Eduard et al. 2012; Milton et al. 1990; Rylander and Vesterlund 1982; Singh et al. 2011b]. Individuals may experience disseminated intravascular coagulopathy, respiratory tract problems, cellular and tissue injury, fever, and other debilitating problems. Endotoxin can be detected in air samples collected on glass filters using the *Limulus* amoebocyte lysate (LAL) assay [Eduard et al. 2012]. This assay uses amoebocytes from the blood-like circulating fluid of the *Limulus polyphemus* (horseshoe crab). After exposure to the lysed amoebocyte cells, the chromogenic version of the LAL enables endotoxins to be quantified [Eduard et al. 2012]. Laboratories use this assay to test for contamination by Gram-negative bacteria [Baron and Finegold 1990].

Although widely used, endotoxin aerosol measurement techniques lack comparability between results obtained in different laboratories because of differing sampling, extraction, and analytical methods [Jacobs 1989; Milton et al. 1990; Olenchock et al. 1983; Rylander and Vesterlund 1982] and water-insoluble endotoxins are not detected [Eduard et al. 2012]. A monoclonal antibody assay has also been developed but it is less sensitive

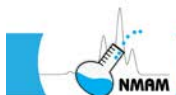

than the LAL method. Similarly, chemical-based approaches are available to detect endotoxins including gas chromatography-mass spectrometry [Eduard et al. 2012].

c. Biochemical analysis methods

Because of the high frequency of isolation of Gram-negative rods in clinical settings, several commercial multi-test systems have been developed for identification of members of the family Enterobacteriaceae and other pathogenic microorganisms. These microorganisms are indistinguishable except for characteristics determined by detailed biochemical testing. These systems require that a pure culture be examined and characterized. A list of some commercially available identification kits is provided in Table III. All of these multitest systems have documented accuracies greater than 90% in clinical settings [Baron and Finegold 1990; Koneman 1988]. For fungi, API (Analytab Products, Plainview, NY) and BIOLOG can also be used to differentiate yeasts based on the respective biochemical and physiological profiles [Flannigan et al. 2011].

d. Chemotaxonomic approaches

Cellular fatty acids (CFA) of bacteria are structural in nature, occurring in the cell membrane or cell wall of all bacteria. When the bacteria are grown under standardized growth conditions, the CFA profiles are reproducible within a genus, down to the subspecies or strain level in some microorganisms. The Sherlock Microbial Identification System (MIS), developed by MIDI (Newark, DE), provides a chromatographic technique and software libraries capable of identifying various microorganisms based on their CFA composition [Sasser 1990a; Sasser 1990b]. The chromatographic technique is also known as gas chromatography fatty acid methyl ester analysis (GC-FAME). MIS has a database containing the analysis libraries for culturable Gram-negative and Gram-positive bacteria, and yeasts. In a comparison study [Amy et al. 1992], only 8 of 18 isolates, identified by either API multitest or MIDI MIS, were identified accurately using BIOLOG multitest. A prototype method for extracting and analyzing fungi is currently being distributed by MIDI.

e. Chemical-based approaches

A variety of chemical-based approaches are available for the detection and quantification of bacteria and fungi in environmental samples [Flannigan et al. 2011; Hung et al. 2005]. Common approaches include thermal desorption - gas chromatography - mass spectrometry (TD-GC-MS), high performance liquid chromatography, gas chromatography-tandem mass spectrometry, and matrix-assisted laser desorption/ionization time of flight (MALDI-TOF) mass spectrometry [Flannigan et al. 2011]. These methods require the formation of a library of markers or spectral signatures that are used to discriminate between various prokaryote and eukaryote species. Examples

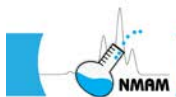

of spectral signatures that have been used for the detection of fungi include microbial volatile organic compounds (mVOCs), mycotoxins, ergosterol, 3-hydroxy fatty acids, muramic acid as well as intracellular and extracellular proteins. NIOSH Method 2549 is a TD-GC-MS based approach that allows for the detection of mVOCs in environmental samples [NIOSH 2003d].

f. High performance liquid chromatography

High performance liquid chromatography (HPLC) is commonly used for bioaerosol “fingerprinting” and biomass determination. Techniques such as proteomics and identifying variations in chromatographic patterns can be used to determine the source of airborne material. For example, ergosterol has been used for decades to detect fungal contamination [Seitz et al. 1979] and even determine taxonomy [Axelsson et al. 1995; Pasanen et al. 1999; Schnurer 1993]. Keratin analysis can be used to identify bioaerosols derived from vertebrates and possibly the habitat within an environment [Staton et al. 2013]. Detection can be as straightforward as using UV absorbance or as complex and specific as employing an ion trap mass spectrometer.

HPLC can be adventitious compared to other methods of analysis; it is an established technology, fairly inexpensive after initial equipment costs, fast and accurate. Its disadvantages include a lack of specificity inherent with detectors using UV absorbance (especially at lower wavelengths), and that complex matrices associated with bioaerosols can prove to be troublesome and may require multi-step enhancement procedures such as solid-phase extraction. Buffered solvent systems are sometimes required, which can be technically difficult to use.

1.) Mycotoxins

Fungal contamination is a concern in food production because it can modify the nutritional content of feed and cereal grains and introduce potentially adverse mycotoxins. Before the use of HPLC, methods of identifying fungal contamination were time consuming or missed non-viable organisms which still contributed to the biomass [Seitz et al. 1979]. HPLC can be used to detect ergosterol, which is a structural sterol nearly universally present in fungi but not naturally present in grains [Pasanen et al. 1999]. HPLC has also been used to detect ergosterol, mannitol and arabitol in bioaerosols [Buiarelli et al. 2013].

Ergosterol is extracted using a liquid-liquid extraction and concentrated. The clean samples are then analyzed by HPLC with UV detection. The ergosterol UV spectrum varies significantly from the UV spectrum of higher plant sterols, making it specific to fungal contaminants. Though the method is still fairly time consuming, it eliminates

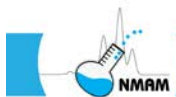

the need for fungal culturing and can detect the presence of non-viable fungi. When combined with other sterols this information can be used to help determine fungal species [Schnurer 1993].

In addition to using sterols to identify fungal contamination, mycotoxins can also be analyzed by liquid chromatography with mass spectrometry (LC-MS). Identification of specific mycotoxins can help identify the species of fungi present [Bennett and Klich 2003; Castillo et al. 2016].

Mycotoxins can play a role in indoor air quality (IAQ), food safety and possibly bioterrorism. The use of LC-MS as a screening tool to identify mycotoxins can reduce the use of more intensive molecular techniques for identification and quantitation. When using mass spectral analysis it is important to have a reliable and accurate database for identification and a qualified analyst to correctly interpret data.

2.) **Other biomolecules**

More recently, HPLC has been proposed as a forensic tool to identify and track vertebrate species using keratin profiles. Like ergosterol in fungi, keratin is found mainly in dander left by vertebrates [Plowman 2007]. If patterns can be established, it may be possible to identify what species had been present in a specific dwelling and possibly even track movements [Staton et al. 2013]. Bacterial contamination can also be tracked using endotoxin analysis and bacterial peptidoglycan fingerprinting [Staton et al. 2013].

3.) **Sample preparation and enhancement**

Bioaerosols can have complex matrices with many interfering constituents. Ultraviolet absorption detectors are fairly inexpensive and straightforward to use, but they can suffer from a lack of specificity and sensitivity. Although mass spectrometry detectors do not suffer from a lack of specificity or sensitivity, a dirty sample can still present challenges.

Another potential pitfall is the presence of large particles in bioaerosol samples. In general, analytical HPLC systems and detectors use small diameter tubing and small orifice injectors that are easily clogged or contaminated by particles. Most analytical systems have some sort of less-expensive trapping or pre-column that can be sacrificed in order to spare the more expensive analytical columns. However, trap columns are still very much an expense and should only be considered if other options are not available. A multitude of cleanup procedures are available to lessen or eliminate problems due to particles, the most common of which are simple centrifugation and

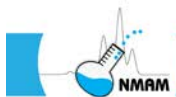

filtration. Both methods will lessen the likelihood of clogging or damaging the system, but neither offers target analyte enrichment.

4.) **Liquid-liquid extraction**

In order to enrich analytes, samples can be concentrated, chemical interferences can be removed, or a combination of both methods can be used. One of the oldest methods of enrichment is a liquid-liquid extraction, which separates analytes based on relative solubility in a given solvent [Koncsag and Barbulescu 2011]. In general, two immiscible solvents are mixed, one solvent containing the whole extract (called the “feed”) and one that ideally solubilizes the analyte of interest preferentially. Based on solubility, the chemical constituents will either stay in the feed solvent or partition into the other solvent. Once the solvents are allowed to phase-separate, the solvent containing the enriched analyte (called the raffinate) is removed.

Liquid-liquid extraction is usually done using an aqueous solvent and an organic solvent. Solvent selection is critical and can be difficult. The goal of the extraction is to choose a solvent that leaves behind as much of the interfering matrix as possible in the feed solvent while also being able to preferentially solvate the analyte of interest. The solvent also must be compatible with the analytical instrumentation. Liquid-liquid extractions tend to use large amounts of solvent, which can result in the analyte of interest being below analytical levels of detection and/or levels of quantitation. Many organic solvents can be easily concentrated by evaporation, but this can pose problems with labile or volatile analytes.

5.) **Solid-phase extraction**

Another option that can help avoid these pitfalls is the use of solid-phase extraction (SPE) [Sigma-Aldrich 1998]. SPE exploits the analyte affinity (or lack thereof) for a solid material packed inside a column. Sample enrichment can occur by the column retaining interfering compounds and the analyte of interest passing through, or by the column retaining the analyte and the interfering chemicals passing through. Concentration of the analyte of interest can be achieved by eluting the analyte in a smaller volume of solvent, and filtration can be achieved simultaneously. SPE may make it possible to achieve analyte concentration and avoid potential losses that could arise from concentrating a large volume of solvent. Appropriate solvent selection is also critical to successful SPE.

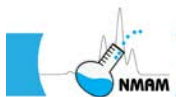

g. Immunoassays

The immunoassay is an analytical technique for measuring a targeted antigen, which is also referred to as an analyte. A critical component of the immunoassay is the antibody or ligand, which binds a specific antigen or binding site. The binding of the antibody or ligand forms the basis for the immunoassay, and numerous formats have been devised which permit visual or instrumental measurements of this reaction. Antibodies include either monoclonal or polyclonal antibodies and these are commonly employed to detect organisms by binding to antigens, usually proteins, polysaccharides or other cell wall components [Hung et al. 2005; Macher 1999]. The analysis is usually performed following extraction of the analytes to form a heterogeneous matrix. In most immunoassays, there is little need for extensive sample cleanup. Following the development of radioimmunoassays, many immunoassays that use monoclonal antibodies are now readily available from commercial sources, permitting laboratories to use standardized immunoassays or rapidly develop in-house immunochemical assays. In addition, commercially available immunoassays or multiplex platforms are available to quantify a variety of indoor or occupational bioaerosol sources [King et al. 2013]. Some of the more widely used immunoassay formats are as follows:

1.) **Enzyme immunoassays (EIA)**

Enzyme Immunoassays (EIA) are composed of a variety of assay formats that can be used to quantify bioaerosols in an air or dust sample. The binding of an antibody or antigen to an enzyme, such as horseradish peroxidase (HRP) or alkaline phosphatase (AP), is the basis of EIA techniques. Enzymatic activity, in the presence of a chromogen, results in a colored end-product that is quantified using a spectrophotometer. Many, if not most, commercially available EIAs are enzyme-linked immunosorbent assays (ELISAs). There are four types of ELISAs which include direct ELISA, indirect ELISA, sandwich ELISA and competitive ELISA.

The sandwich ELISA method is typically used for the detection for airborne viruses and aeroallergens [Hung et al. 2005]. In this assay, a capture antibody is bound to a solid surface, usually a 96-well plate. The bioaerosol extract is added to the plate containing the capture antibody and incubated for a specified length of time, washed with a phosphate buffer solution and probed with an enzyme-labeled antibody that enables detection and quantification, either through colorimetric changes or fluorescence emissions. The advantages to using a sandwich-based ELISA method are that it is highly specific and can be used on complex samples such as aerosols. Some disadvantages to using a sandwich-based ELISA are poor antibody recognition and/or minimal detection due to low sample concentration. Lastly, it should be noted that ELISA, like any protein-based assay, does not distinguish between viable and non-

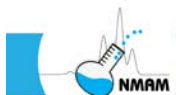

viable viral aerosols. Multiplexed technologies that enable the detection and quantification of multiple allergen sources in one sample are also available from a variety of commercial sources [King et al. 2013].

EIA methods to assess fungal bioaerosols based on the detection of fungal cell wall components, enzymes, antigens and allergens have become commercially available. β -1,3-D glucan, extracellular polysaccharides, mycotoxins and a variety of fungal antigens can now be quantified in air and dust samples using immunochemical, enzymatic and chemical detection platforms [Chew et al. 2001; Douwes et al. 1997; Eduard et al. 2012]. Although many of these biomarkers and methods serve as a proxy measure for total fungal biomass, these approaches can be confounded by limitations associated with component extraction biases. In addition, complex extraction, washing, amplification or immunochemistry steps are required that may add hours or even days before a dataset is finalized for analysis and interpretation.

To date, there are a number of commercial companies that have developed ready to use EIA kits for the detection and quantification of a variety of indoor and occupational biomarkers including dog, cat, dust mite, fungal and rodent allergens [Filep et al. 2012]. These EIA approaches enable the collection and quantification of these biomarkers in the work environment and provide a ready to use platform for the industrial hygienist.

2.) **Fluorescent immunoassays (FIA)**

Utilization of fluorescent-labeled antibodies to detect bacterial antigens was introduced by Coons et al. [1941; 1942]. Various FIA techniques have now evolved and are commonly utilized in laboratories. These include: (1) direct FIA, to detect cell-bound antigens using a fluorescent antibody; (2) indirect FIA to detect cell-bound antigens using a primary antibody and a fluorescent secondary antibody; and (3) indirect FIA to detect serum antibodies using an antigen, serum, and a fluorescent antibody. Various fluorescent dyes, such as fluorescein, fluorescein isothiocyanate, and rhodamine isothiocyanate, may be employed [Thermo Fisher Scientific 2014]. A fluorescent or confocal microscope is used to evaluate the samples and to count the number of fluorescently stained organisms [Garvey et al. 1977; Popp et al. 1988]. Similarly, flow cytometry-based approaches using fluorescent-labelled antibodies have also been employed to evaluate a variety of bioaerosol sources including bacteria, pollen and fungi [Rittenour et al. 2012; Rule et al. 2007; Rydjord et al. 2007]. Multiplexed approaches have been developed for the detection of multiple allergens in the same extracted sample [King et al. 2013].

FIA can be used to detect viruses. An example of a direct FIA assay for the detection of virus-laden aerosols is the Focus Forming Assay (FFA) [Flint et al. 2009a]. With the

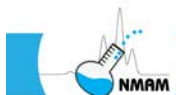

FFA, fluorescent microscopy is used to visualize immunostained cells and viral titers are quantified as focus forming units per milliliter, or FFU/mL. While the FFA is more sensitive than culture-based methods alone, samples with low viral titers may weakly fluoresce and possibly be considered undetectable. To overcome weak detection levels, an indirect IFA assay may be more appropriate [Leland and Emanuel 1995; Madeley and Peiris 2002]. With indirect IFA assays, a primary, unconjugated antibody is used in combination with a fluorophore-conjugated, secondary antibody directed against the primary antibody. Because the secondary antibody is able to bind to multiple epitopes on the primary antibody, it increases fluorescence and enhances overall detection. While IFA is a trusted method of viral detection and quantification, it is fraught with limitations including excessive cost and the necessity of a skilled technician experienced in the reading of immunofluorescence. Likewise, because viruses are constantly undergoing antigenic drift and occasionally antigenic shift, changes in viral antigens can affect the binding affinity of the primary antibody and may result in false negatives.

3.) Ligand-based assays

As an alternative to cell culture and immunofluorescent-based assays, there are several protein-based methods of detection that can be used to quantify viral loads in an aerosol sample. The hemagglutination (HA) assay is a non-fluorescence quantitative assay that is based upon the ability of certain viral pathogens to agglutinate species-specific erythrocytes [Condit 2007]. In a serial twofold dilution, viral samples are mixed with a 1% solution of erythrocytes and incubated at room temperature for 30-60 minutes. Viral samples which form an agglutinated lattice are able to prevent red blood cells from precipitating out of solution by the binding of the hemagglutinin protein (present on the surface of the viral pathogen) to the sialic acid receptors (present on the surface of red blood cells). The titer of the sample is based on the well with the last agglutinated appearance, immediately before the well in which the red blood cells have settled out of solution. Hemagglutination units (HAUs) are typically used to quantify the viral concentration.

One of the major limitations of the HA assay is that it does not distinguish between infectious and non-infectious viral particles. Likewise, certain bacteria and fungi possess hemolytic activity and when present in a collected bioaerosol, can alter the HA assay and result in false positive readings. To circumvent this issue, a variation of the HA assay, known as the Hemagglutination-Inhibition test, can be performed [Stewart et al. 1967]. The HA inhibition test measures serum antibodies that are directed against the viral pathogen. When present in sufficient concentration, the serum antibodies are able to prevent agglutination of red blood cells thereby providing an alternative means of quantifying viral loads.

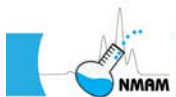

4.) **Direct and indirect immunostaining**

Direct and indirect immunostaining methods have been previously described for the detection of bioaerosol sources. Popp et al. [1988] developed a staining technique to enumerate bioaerosol samples directly captured on microscope slides. These approaches have enabled the identification of specific bioaerosol sources, especially those that do not contain morphological phenotypes that would be used by a trained microbiologist to resolve and identify a specific microorganism [Popp et al. 1988]. Alternatives to this approach have been developed and utilized in a variety of indoor and occupational environments. A press blotting approach that included immobilizing proteins from collected bioaerosols captured on an adhesive tape provided insight into the bioaerosols that contain allergen in the outdoor environment [Takahashi et al. 1993; Takahashi and Nilsson 1995]. An alternative method, called the Halogen Immunoassay, enables the immunostaining of allergen and antigen around bioaerosols captured on a protein binding membrane such as PVDF or mixed cellulose ester [Green et al. 2006c; Tovey et al. 2000]. This immunoassay approach has been used in a variety of indoor and occupational settings to evaluate allergen sources including, cat, dog, latex, rodent, plant, and fungi [Green et al. 2006a; Green et al. 2003; Green et al. 2005a; Green et al. 2011; Green et al. 2005b; Green et al. 2005c; Green et al. 2006b; Green et al. 2006c; Mitakakis et al. 2001; Poulos et al. 2002; Poulos et al. 1999; Razmovski et al. 2000; Renstrom 2002; Tovey and Green 2004]. Recently these approaches have been adapted to FESEM applications and have been used to detect morphologically indiscernible fungal fragments [Afanou et al. 2015].

5.) **Biosensors**

To overcome some of the technical challenges associated with traditional methods to assess bioaerosol exposure, real-time sensor technologies are being developed for the detection of bioaerosols [Fronczek and Yoon 2015; Hook-Barnard et al. 2014]. The sensor technologies are based on a variety of signal detection strategies that include optical, mechanical, electrical, or magnetic sensing approaches. These methods have resulted in platforms that have enabled the rapid detection of microbial pathogens and in an automated format. Using this technology requires little technological skill and can be developed into an automated handheld device. These developments have resulted in the fabrication of remote monitoring units in the agricultural sector that can process data remotely and apply it to geographical information systems or forecasting models.

Biosensors have been developed for a variety of applications including the detection of microbial pathogens [Fronczek and Yoon 2015; Hook-Barnard et al. 2014]. Typically, a biologically derived analyte (such as fungal spores, hyphae, antigens, peptides or nucleotides) is collected and interacts with a selected bioreceptor immobilized on a

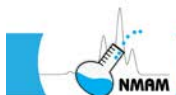

sensor surface. Examples of bioreceptors include oligonucleotides, monoclonal/polyclonal antibodies, enzymes, cells, and even phages. The bioreceptor system consists of a physiochemical transducer that produces a measurable signal. Transducers can be optical and include surface plasmon resonance (SPR), which is a method that measures changes in the refractive index during molecular binding events [Unser et al. 2015; Usachev et al. 2014]. In contrast, electrochemical transducers measure changes in current, potential, impedance, and conductance across an electrode surface for detection events [Patolsky et al. 2006]. Examples of electrochemical detection include the measurement of electrical conductance produced by antibody-antigen binding events [Patolsky et al. 2004]. Both optical and electrochemical transducers have been developed for the detection of a variety of pathogens in the biosecurity, medical and agricultural sectors.

h. Gene-based assays

Cell culture, protein-based, and immunological-based assays are invaluable diagnostic tools. However, the evolution of nucleic acid-based molecular diagnostics are rapidly becoming the preferred method for detecting and quantifying bioaerosols [West et al. 2008]. Nucleic acid-based molecular diagnostics can be divided into two categories, (1) Direct sample analysis and (2) Indirect sample analysis, such as the Viral Replication Assay (VRA), which requires cultivation of the target microorganism prior to molecular analysis [Blachere et al. 2011]. Regardless of which approach is taken, there are three steps involved: extraction and purification of nucleic acids; amplification of the gene target; and detection of the amplicon. For viral, bacterial, plant and fungal nucleic acid extraction and purification, a number of kits are commercially available. Such kits generally rely upon either silica adsorption (spin-column) or affinity purification (magnetic separation) methodologies. Because bioaerosols are typically dilute in nature, investigators should determine which method yields the greatest amount of nucleic acids while minimizing sample handling, contamination and degradation. These are important variables to consider and can vary depending on the selected approach.

With the advent of molecular assays such as the Polymerase Chain Reaction (PCR) and Real-Time Quantitative PCR (RT-qPCR), which detect specific genetic sequences in the sample DNA or RNA, it has been possible to provide standardized assays, reduce turnaround time, and enhance assay sensitivity and detection specificity [Cella et al. 2013; Life Technologies 2014; Mahony 2008]. Using gene-specific oligonucleotides coupled with either an intercalating fluorescent dye (e.g. SYBR green) or a fluorogenically labeled gene probe (e.g. VIC, 6FAM), industrial hygienists are able to monitor indoor and outdoor bioaerosols for the presence of microorganisms. Likewise, multiplexing PCR and bead-based multiplexing PCR, which couples PCR and flow-cytometry, can be used for high-

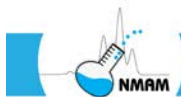

throughput screening of multiple respiratory viruses in a single reaction mixture. It should be noted that poor assay design, primer and probe base-pair mismatches and degraded template nucleic acids can lead to false negatives or reduced detection sensitivity. Investigators should ensure optimal assay design, validate limits of detection, and run valid PCR controls in parallel.

Within the last two decades, a variety of molecular technologies have been used to quantify eukaryotic biomass including fungi and plant pollen in occupational, health, residential, and industrial samples [Rittenour et al. 2012; Scott et al. 2011; Summerbell et al. 2011]. Examples of these technologies include molecular based methods to evaluate specific or conserved gene loci (internal transcribed spacer region of ribosomal RNA) such as Sanger [Rittenour et al. 2014] or next generation sequencing [Kettleson et al. 2015], denaturing gradient gel electrophoresis [Johansson et al. 2014] and quantitative PCR [Eduard et al. 2012; Vesper et al. 2007]. The latter approach includes examples such as a DNA-based mold specific quantitative PCR (msQPCR) method that enables the detection and quantification of 36 indicator fungal species [Vesper et al. 2007]. This msQPCR method has been used to develop an Environmental Relative Moldiness Index (ERMI) to quantify the mold burden in homes. Originally developed by the U.S. Environmental Protection Agency (EPA) [Vesper et al. 2007], this approach has been licensed to a variety of companies in the commercial sector and is widely used to evaluate indoor fungal bioaerosol particles in settled dust during investigations of indoor air quality [Bolaños-Rosero et al. 2013; Kettleson et al. 2015; Reponen et al. 2012; Reponen et al. 2011a; Taubel et al. 2016; Vesper et al. 2013; Vesper et al. 2007]. The development of this methodology has provided the first step towards a standardized approach to quantify fungal bioaerosol sources within the indoor environment. Other metagenomic molecular methods including Sanger, 454, and Illumina miSeq sequencing platforms have also provided new insights into the complete diversity of bacterial and fungal bioaerosols in indoor, outdoor and occupational environments.

10 Limitations of bioaerosol sampling and characterization

Bioaerosol sampling can be a useful tool to study occupational exposures, potential health hazards, and the transmission of infectious diseases. However, bioaerosol sampling has significant limitations, and these need to be kept in mind when deciding whether or not to collect bioaerosol samples, preparing a sampling plan, and interpreting the results.

The first and most important limitation is the lack of standards and guidelines for acceptable bioaerosol exposure limits. NIOSH and other organizations have set recommended exposure



limits for several organic materials which may contain microorganisms and their fragments, such as cotton dust, grain dust, starch and wood dust [NIOSH 2010]. Although numerous studies have suggested a connection between exposure to various bioaerosols and respiratory illnesses, exposure limits do not currently exist in the US for airborne pollen, fungi, protozoa, bacteria, viruses, or their fragments. These limits have not been established largely because it is not possible to definitively state that a particular bioaerosol concentration will or will not lead to adverse health outcomes [Eduard et al. 2012; Heederik 2013; Morey 2007; Nevalainen et al. 2015; NIOSH 2012a]. This is true for several reasons: bioaerosols are often a complex mixture of microorganisms and organic materials; thousands of species of microorganisms exist, and most have not been studied; microorganisms and their fragments can cause illnesses in a variety of ways, including allergic reactions, infections and toxicity; the health effects of biological materials can vary substantially from person to person; and sampling and analytical procedures are not standardized, which makes it difficult to compare results [Eduard et al. 2012; Heederik 2013; Morey 2007; Nevalainen et al. 2015; Taubel et al. 2016]. Although research is ongoing, no standards for acceptable levels of bioaerosols in the environment have been established by the US government or organizations such as the ACGIH or the AIHA.

In addition to the lack of occupational exposure limits for bioaerosols, measuring and interpreting bioaerosol concentrations are more complex than is often appreciated. Bioaerosol concentrations can vary significantly from location to location within a building, especially if the bioaerosol has one or a few localized sources. A study of bioaerosol exposure in a large engine plant found that levels of airborne fungi, bacteria and endotoxin varied from location to location within the plant [Thorne et al. 1996]. A study of airborne fungi in two residences found significant differences between two rooms sampled at the same time [Hyvarinen et al. 2001]. In healthcare settings, patients with certain respiratory infections expel bioaerosol particles containing infectious pathogens. Because of the dispersion of the aerosol and the settling of larger droplets, the bioaerosol concentration decreases rapidly as the distance from the patient increases [Jones and Brosseau 2015]. A study of airborne influenza in a healthcare clinic found that the concentrations were much higher in examination rooms containing patients with influenza than other locations, and that the airborne influenza concentration also varied from location to location within the waiting room [Lindsley et al. 2010a].

Most bioaerosol collection methods provide a snapshot of the environmental bioaerosols at a specific time. Temporal variations in bioaerosol concentrations are commonly observed, especially if the bioaerosol generation occurs during episodic events rather than continuously. One study of indoor airborne mold in a residence found that day-to-day concentrations of airborne fungi varied considerably, and that levels were 26 times higher in the summer than in the winter [LeBouf et al. 2008]. Another residential study found that more airborne fungi were present in the morning than the afternoon and earlier in the winter compared to later [Hyvarinen et al. 2001]. In the influenza study mentioned above, day-to-day levels of airborne



influenza virus varied considerably depending upon the number of influenza patients present [Lindsley et al. 2010a].

Other factors also influence bioaerosol concentrations. Building airflow patterns and the operation of the HVAC system can affect bioaerosol levels, particularly if the HVAC system is a source of bioaerosol particles [Macher 1999]. Areas occupied by people show increased levels of bioaerosols compared to empty spaces, both because people themselves shed bioaerosol particles and because human activities such as walking and sitting can re-suspend dust from floors and furniture [Buttner and Stetzenbach 1993; Ferro et al. 2004; Hung et al. 2005; Qian et al. 2012]. Outdoor air is an important source of airborne fungi in many indoor environments due to fresh air being drawn in by HVAC systems and infiltration through cracks and openings [Eduard 2009].

Because of these issues, if bioaerosol sampling is to be conducted, it needs to be a part of a well-planned and comprehensive sampling strategy. The development of a sampling plan should begin with a thorough inspection and understanding of the workplace, including the building, HVAC system, and possible sources of bioaerosols. The sampling plan should integrate other types of data collection with the bioaerosol sampling, such as bulk sampling of possible source materials, surface sampling of settled dust, and health surveys of workers. Collections will need to be carried out at multiple locations and multiple time points, and even then it must be kept in mind that such samples may not fully characterize the exposure and that false negative results are quite possible [ASTM 2014a; Hung et al. 2005; Macher 1999; Morey 2007].

Bioaerosol sampling can be beneficial when done in the appropriate context [Hung et al. 2005; Macher 1999; Morey 2007]. It can be helpful to compare indoor and outdoor levels of bioaerosols to identify possible indoor problem microorganisms. Sampling for specific microorganisms of concern can be useful, especially if there is a known source, such as a composting operation or an aeration tank in a sewage treatment facility [Environment Agency 2009; Masclaux et al. 2014]. Bioaerosol sampling is also a valuable research tool for better understanding sources and exposures. On the other hand, sampling for bioaerosols will not be helpful if there is not some basis for interpreting the resulting data. For example, because of the lack of dose-response information and the variability associated with bioaerosol sampling, NIOSH does not recommend routine air sampling when investigating possible respiratory illness due to exposures in damp buildings. Instead, NIOSH recommends inspections of the building and its HVAC systems to locate moisture and microbial growth problems, followed by remediation [NIOSH 2012a].



11 Safety considerations

Investigators should use appropriate personal protective equipment (PPE) and practice good personal hygiene when conducting indoor environmental quality, disease outbreaks, and agricultural health investigations that have resulted in medically diagnosed symptoms. PPE may include respiratory protection to prevent inhalation of microbes and microorganism-resistant clothing to prevent transmission to investigators by bodily contact with microorganisms. Good personal hygiene practices include washing exposed skin and clothing thoroughly and refraining from eating, drinking, or smoking in a contaminated area. These simple steps will help minimize the ingestion, inhalation, or uptake of microorganisms.

All samplers, culture plates, and other equipment should be handled aseptically to prevent contamination of the samples and, more importantly, to prevent the spread of potential human pathogens to the worker or the work environment. All surfaces, including washed hands, may harbor microorganisms or spores unless they are specifically sterilized. Practically speaking, however, not all objects can be sterilized. While disinfection with an oxidizing chemical or alcohol destroys most vegetative cells, these agents do not destroy all spores. Samplers should be disinfected or, if possible, sterilized after each sample collection. Special care should be given to samplers with convoluted inlets or air pathways where microorganisms may accumulate.

Information on the safe handling of biological specimens can be found in the free online manual “Biosafety in Microbiological and Biomedical Laboratories” from the Centers for Disease Control and Prevention at (<http://www.cdc.gov/biosafety/publications/bmbl5/index.htm>) [CDC 2009]. Information on the handling of some specific pathogens can also be found at the CDC website (www.cdc.gov).

12 Resources

The NIOSH Manual of Analytical Methods has several chapters discussing other aspects of aerosol sampling, including general considerations and factors affecting aerosol sampling, an explanation of filter pore size, sampling airborne fibers, sampler wall losses, and avoiding bypass leakage in filter cassettes [NIOSH 2003e]. NIOSH also maintains a web page on indoor environmental quality with more information and links to additional resources at <http://www.cdc.gov/niosh/topics/indoorenv/>. The American Industrial Hygiene Association (AIHA; <https://www.aiha.org>) has reference materials and resources on indoor air quality and bioaerosols, as does the American Conference of Governmental Industrial Hygienists (ACGIH; <http://www.acgih.org>). ASTM International (<http://www.astm.org>) publishes numerous standards and guides on the evaluation of indoor air quality, including developing



an air sampling strategy and the collection and evaluation of bioaerosols [ASTM 2009; ASTM 2014a; ASTM 2014b; ASTM 2014d; ASTM 2014e]. The Centers for Disease Control and Prevention has guidelines on environmental infection control in healthcare facilities that include recommendations on environmental sampling [CDC 2003].

Disclaimer

Mention of any company or product does not constitute endorsement by NIOSH. In addition, citations to websites external to NIOSH do not constitute NIOSH endorsement of the sponsoring organizations or their programs or products. Furthermore, NIOSH is not responsible for the content of these websites. All web addresses referenced in this document were accessible as of the publication date.

13 References

- Abed Y, Boivin G [2006]. Treatment of respiratory virus infections. *Antiviral Res* 70(2):1-16.
- ACGIH [1989]. Guidelines for the assessment of bioaerosols in the indoor environment. Cincinnati, OH: American Conference of Governmental Industrial Hygienists.
- ACGIH [2001]. Documentation of the Threshold Limit Values and Biological Exposure Indices. Appendix C: Particle size-selective sampling criteria for airborne particulate matter. Cincinnati, Ohio: American Conference of Governmental Industrial Hygienists.
- ACGIH [2015]. TLVs and BEIs based on the documentation of the Threshold Limit Values for chemical substances and physical agents and Biological Exposure Indices. Cincinnati, OH: American Conference of Governmental Industrial Hygienists.
- Adams RI, Tian Y, Taylor JW, Bruns TD, Hyvarinen A, Taubel M [2015]. Passive dust collectors for assessing airborne microbial material. *Microbiome* 3:46.
- Adhikari A, Reponen T, Rylander R [2013]. Airborne fungal cell fragments in homes in relation to total fungal biomass. *Indoor Air* 23(2):142-147.
- Afanou KA, Straumfors A, Skogstad A, Nayak AP, Skaar I, Hjeljord L, Tronsmo A, Eduard W, Green BJ [2015]. Indirect immunodetection of fungal fragments by field emission scanning electron microscopy. *Appl Environ Microbiol* 81(17):5794-5803.



Afanou KA, Straumfors A, Skogstad A, Nilsen T, Synnes O, Skaar I, Hjeljord L, Tronsmo A, Green BJ, Eduard W [2014]. Submicronic fungal bioaerosols: high-resolution microscopic characterization and quantification. *Appl Environ Microbiol* 80(22):7122-7130.

Amy PS, Haldeman DL, Ringelberg D, Hall DH, Russell C [1992]. Comparison of identification systems for classification of bacteria isolated from water and endolithic habitats within the deep subsurface. *Appl Environ Microbiol* 58(10):3367-3373.

Andersen AA [1958]. New sampler for the collection, sizing, and enumeration of viable airborne particles. *J Bacteriol* 76(5):471-484.

Appert J, Raynor PC, Abin M, Chander Y, Guarino H, Goyal SM, Zuo ZL, Ge S, Kuehn TH [2012]. Influence of suspending liquid, impactor type, and substrate on size-selective sampling of MS2 and adenovirus aerosols. *Aerosol Sci Technol* 46(3):249-257.

Arantes TD, Theodoro RC, Da Graca Macoris SA, Bagagli E [2013]. Detection of *Paracoccidioides* spp. in environmental aerosol samples. *Med Mycol* 51(1):83-92.

Artenstein MS, Miller WS, Lamson TH, Brandt BL [1968]. Large-volume air sampling for meningococci and adenoviruses. *Am J Epidemiol* 87(3):567-577.

Artenstein MS, Miller WS, Rust JH Jr., Lamson TH [1967]. Large-volume air sampling of human respiratory disease pathogens. *Am J Epidemiol* 85(3):479-485.

Ashley K, Harper M [2013]. Closed-face filter cassette (CFC) sampling-guidance on procedures for inclusion of material adhering to internal sampler surfaces. *J Occup Environ Hyg* 10(3):D29-33.

ASHRAE [2000]. D-86815 Guideline 12-2000 -- Minimizing the risk of legionellosis associated with building water systems. Atlanta, GA: American Society of Heating, Refrigerating and Air-Conditioning Engineers.

ASHRAE [2009]. Indoor air quality guide: best practices for design, construction and commissioning. Atlanta, GA: American Society of Heating, Refrigerating and Air-conditioning Engineers.

ASHRAE [2015]. ANSI/ASHRAE Standard 188-2015 Legionellosis: risk management for building water systems. Atlanta, GA: American Society of Heating, Refrigerating and Air-Conditioning Engineers.



- ASTM [2009]. D7391-09 Standard test method for categorization and quantification of airborne fungal structures in an inertial impaction sample by optical microscopy. West Conshohocken, PA: ASTM International.
- ASTM [2012]. D7789-12 Standard practice for collection of fungal material from surfaces by swab. West Conshohocken, PA: ASTM International.
- ASTM [2014a]. E1370-14 Standard guide for air sampling strategies for worker and workplace protection. West Conshohocken, PA: ASTM International.
- ASTM [2014b]. D7338-14 Standard guide for assessment of fungal growth in buildings. West Conshohocken, PA: ASTM International.
- ASTM [2014c]. D7910-14 Standard practice for collection of fungal material from surfaces by tape lift. West Conshohocken, PA: ASTM International.
- ASTM [2014d]. D7788-14 Standard practice for collection of total airborne fungal structures via inertial impaction methodology. West Conshohocken, PA: ASTM International.
- ASTM [2014e]. D7297-14 Standard practice for evaluating residential indoor air quality concerns. West Conshohocken, PA: ASTM International.
- ASTM [2015]. ASTM D5952 - 08(2015) Standard guide for the inspection of water systems for Legionella and the investigation of possible outbreaks of legionellosis (Legionnaires' Disease or Pontiac Fever). West Conshohocken, PA: ASTM International.
- ATS [1990]. American Thoracic Society. Diagnostic standards and classification of tuberculosis. *Am Rev Respir Dis* 142(3):725-735.
- Axelsson BO, Saraf A, Larsson L [1995]. Determination of ergosterol in organic dust by gas chromatography-mass spectrometry. *J Chromatogr B Biomed Sci Appl* 666(1):77-84.
- Babady NE, Buckwalter SP, Hall L, Le Febre KM, Binnicker MJ, Wengenack NL [2011]. Detection of *Blastomyces dermatitidis* and *Histoplasma capsulatum* from culture isolates and clinical specimens by use of real-time PCR. *J Clin Microbiol* 49(9):3204-3208.
- Banaszak EF, Thiede WH, Fink JN [1970]. Hypersensitivity pneumonitis due to contamination of an air conditioner. *N Engl J Med* 283(6):271-276.



Baron EJ, Finegold SM [1990]. *Bailey & Scott's Diagnostic Microbiology*, 8th edition. St. Louis: Mosby.

Baron PA, Deye GJ [1990]. Electrostatic effects in asbestos sampling. I: Experimental measurements. *Am Ind Hyg Assoc J* 51(2):51-62.

Beaulieu HJ, Fidino AV, Arlington KL, Buchan RM [1980]. A comparison of aerosol sampling techniques: "open" versus "closed-face" filter cassettes. *Am Ind Hyg Assoc J* 41(10):758-765.

Bennett JW, Klich M [2003]. Mycotoxins. *Clin Microbiol Rev* 16(3):497-516.

Bhangar S, Adams RI, Pasut W, Huffman JA, Arens EA, Taylor JW, Bruns TD, Nazaroff WW [2016]. Chamber bioaerosol study: human emissions of size-resolved fluorescent biological aerosol particles. *Indoor Air* 26(2):193-206.

Blachere FM, Cao G, Lindsley WG, Noti JD, Beezhold DH [2011]. Enhanced detection of infectious airborne influenza virus. *J Virol Methods* 176(1-2):120-124.

Blachere FM, Lindsley WG, Pearce TA, Anderson SE, Fisher M, Khakoo R, Meade BJ, Lander O, Davis S, Thewlis RE, Celik I, Chen BT, Beezhold DH [2009]. Measurement of airborne influenza virus in a hospital emergency department. *Clin Infect Dis* 48(4):438-440.

Blais Lecours P, Veillette M, Marsolais D, Duchaine C [2012]. Characterization of bioaerosols from dairy barns: reconstructing the puzzle of occupational respiratory diseases by using molecular approaches. *Appl Environ Microbiol* 78(9):3242-3248.

Bolaños-Rosero B, Betancourt D, Dean T, Vesper S [2013]. Pilot study of mold populations inside and outside of Puerto Rican residences. *Aerobiologia* 29(4):537-543.

Bonifait L, Charlebois R, Vimont A, Turgeon N, Veillette M, Longtin Y, Jean J, Duchaine C [2015]. Detection and quantification of airborne norovirus during outbreaks in healthcare facilities. *Clin Infect Dis* 61(3):299-304.

Booth TF, Kournikakis B, Bastien N, Ho J, Kobasa D, Stadnyk L, Li Y, Spence M, Paton S, Henry B, Mederski B, White D, Low DE, McGeer A, Simor A, Vearncombe M, Downey J, Jamieson FB, Tang P, Plummer F [2005]. Detection of airborne severe acute respiratory syndrome (SARS) coronavirus and environmental contamination in SARS outbreak units. *J Infect Dis* 191(9):1472-1477.



Brasel TL, Douglas DR, Wilson SC, Straus DC [2005]. Detection of airborne *Stachybotrys chartarum* macrocyclic trichothecene mycotoxins on particulates smaller than conidia. *Appl Environ Microbiol* 71(1):114-122.

Breuer D [2012]. Flow resistance of samplers for personal monitoring in work areas and requirements for sampling pump performance. *J Occup Environ Hyg* 9(2):D25-32.

Brockmann JE [2011]. Aerosol transport in sampling lines and inlets. In: Kulkarni P, Baron PA, Willeke K, eds. *Aerosol measurement: principles, techniques, and applications*. Hoboken, NJ: John Wiley & Sons.

Brown RC, Hemingway MA, Wake D, Thorpe A [1996]. Electret-based passive dust sampler: sampling of organic dusts. *Analyst* 121(9):1241-1246.

Buiarelli F, Canepari S, Di Filippo P, Perrino C, Pomata D, Riccardi C, Speziale R [2013]. Extraction and analysis of fungal spore biomarkers in atmospheric bioaerosol by HPLC-MS-MS and GC-MS. *Talanta* 105:142-151.

Burge HP, Boise JR, Rutherford JA, Solomon WR [1977]. Comparative recoveries of airborne fungus spores by viable and non-viable modes of volumetric collection. *Mycopathologia* 61(1):27-33.

Buttner MP, Stetzenbach LD [1993]. Monitoring airborne fungal spores in an experimental indoor environment to evaluate sampling methods and the effects of human activity on air sampling. *Appl Environ Microbiol* 59(1):219-226.

Carvalho E, Sindt C, Verdier A, Galan C, O'Donoghue L, Parks S, Thibaudon M [2008]. Performance of the Coriolis air sampler, a high-volume aerosol-collection system for quantification of airborne spores and pollen grains. *Aerobiologia* 24(4):191-201.

Castillo NI, Ibanez M, Beltran E, Rivera-Monroy J, Ochoa JC, Paez-Castillo M, Posada-Buitrago ML, Sulyok M, Hernandez F [2016]. Identification of mycotoxins by UHPLC-QTOF MS in airborne fungi and fungi isolated from industrial paper and antique documents from the Archive of Bogota. *Environ Res* 144(Pt A):130-138.



CDC [2003]. Guidelines for environmental infection control in health-care facilities. Recommendations of CDC and the Healthcare Infection Control Practices Advisory Committee (HICPAC). Atlanta, GA: U.S. Department of Health and Human Services, Centers for Disease Control and Prevention, http://www.cdc.gov/hicpac/pdf/guidelines/eic_in_HCF_03.pdf.

CDC [2009]. Biosafety in microbiological and biomedical laboratories, 5th edition. Chosewood LC, Wilson DE, eds. Washington DC: U.S. Department of Health and Human Services, Centers for Disease Control and Prevention, National Institutes of Health, DHHS (CDC) Publication No. 21-1112, <http://www.cdc.gov/biosafety/publications/bmbl5/index.htm>.

CDC [2015]. Sampling procedure and potential sampling sites. Protocol for collecting environmental samples for Legionella culture during a cluster or outbreak investigation or when cases of disease may be associated with a facility. Atlanta, GA: U.S. Department of Health and Human Services, Centers for Disease Control and Prevention, <http://www.cdc.gov/legionella/downloads/cdc-sampling-procedure.pdf>.

Cella LN, Blackstock D, Yates MA, Mulchandani A, Chen W [2013]. Detection of RNA viruses: current technologies and future perspectives. *Crit Rev Eukaryot Gene Expr* 23(2):125-137.

CEN [2000]. EN 13098:2000 Workplace atmosphere - Guidelines for measurement of airborne micro-organisms and endotoxin. Brussels, Belgium: European Committee for Standardization.

CEN [2003]. EN 14031:2003 Workplace atmospheres - Determination of airborne endotoxins. Brussels, Belgium: European Committee for Standardization.

CEN [2004]. EN 14583:2004 Workplace atmospheres - Volumetric bioaerosol sampling devices - Requirements and test methods. Brussels, Belgium: European Committee for Standardization.

Chang C-W, Chou F-C [2011]. Assessment of bioaerosol sampling techniques for viable *Legionella pneumophila* by ethidium monoazide quantitative PCR. *Aerosol Sci Technol* 45(3):343-351.

Cherrie JW, Maccalman L, Fransman W, Tielemans E, Tischer M, Van Tongeren M [2011]. Revisiting the effect of room size and general ventilation on the relationship between near- and far-field air concentrations. *Ann Occup Hyg* 55(9):1006-1015.



- Chew GL, Douwes J, Doekes G, Higgins KM, van Strien R, Spithoven J, Brunekreef B [2001]. Fungal extracellular polysaccharides, beta (1 -> 3)-glucans and culturable fungi in repeated sampling of house dust. *Indoor Air* 11(3):171-178.
- Condit RC [2007]. Principles of virology. In: Knipe DM, Howley PM, eds. *Fields virology*. Philadelphia: Lippincott, Williams & Wilkins.
- Coons AH, Creech HJ, Jones RN [1941]. Immunological properties of an antigen containing a fluorescent group. *Proc Soc Exp Biol Med* 47:200-202.
- Coons AH, Creech HJ, Jones RN, Berliner E [1942]. The demonstration of pneumococcal antigen in tissues by use of fluorescent antibody. *J Immunol* 45:159-170.
- Corzo CA, Culhane M, Dee S, Morrison RB, Torremorell M [2013]. Airborne detection and quantification of swine influenza A virus in air samples collected inside, outside and downwind from swine barns. *PLoS ONE* 8(8):e71444.
- Cown WB, Kethley TW, Fincher EL [1957]. The critical-orifice liquid impinger as a sampler for bacterial aerosols. *Appl Microbiol* 5(2):119-124.
- Cox CS [1968]. The aerosol survival of *Escherichia coli* B in nitrogen, argon and helium atmospheres and the influence of relative humidity. *J Gen Microbiol* 50(1):139-147.
- Cox CS [1987]. *The aerobiological pathway of microorganisms*. New York: Wiley.
- Cox CS [1989]. *Airborne bacteria and viruses*. *Sci Prog* 73(292 Pt 4):469-499.
- Custis NJ, Woodfolk JA, Vaughan JW, Platts-Mills TA [2003]. Quantitative measurement of airborne allergens from dust mites, dogs, and cats using an ion-charging device. *Clin Exp Allergy* 33(7):986-991.
- Das R, McNary J, Fitzsimmons K, Dobraca D, Cummings K, Mohle-Boetani J, Wheeler C, McDowell A, Iossifova Y, Bailey R, Kreiss K, Materna B [2012]. Occupational coccidioidomycosis in California: outbreak investigation, respirator recommendations, and surveillance findings. *J Occup Environ Med* 54(5):564-571.
- Davies A, Thomson G, Walker J, Bennett A [2009]. A review of the risks and disease transmission associated with aerosol generating medical procedures. *J Infect Prev* 10(4):122-126.



Demirjian A, Lucas CE, Garrison LE, Kozak-Muiznieks NA, States S, Brown EW, Wortham JM, Beaudoin A, Casey ML, Marriott C, Ludwig AM, Sonel AF, Muder RR, Hicks LA [2015]. The importance of clinical surveillance in detecting Legionnaires' disease outbreaks: a large outbreak in a hospital with a Legionella disinfection system-Pennsylvania, 2011-2012. *Clin Infect Dis* 60(11):1596-1602.

Dennis PJJ [1990]. An unnecessary risk: Legionnaires' disease. In: Morey PR, Feeley JC, Otten JA, eds. *Biological contaminants in indoor environments*. Philadelphia: ASTM.

Donaldson AI, Ferris NP, Gloster J [1982]. Air sampling of pigs infected with foot-and-mouth disease virus: comparison of Litton and cyclone samplers. *Res Vet Sci* 33(3):384-385.

Douwes J, Doekes G, Montijn R, Heederik D, Brunekreef B [1997]. An immunoassay for the measurement of (1 → 3)-beta-D-glucans in the indoor environment. *Mediators Inflamm* 6(4):257-262.

Dungan RS, Leytem AB [2015]. Recovery of culturable *Escherichia coli* O157:H7 during operation of a liquid-based bioaerosol sampler. *Aerosol Sci Technol* 50(1):71-75.

Dyer RL, Frank JF, Johnson B, Hickey P, Fitts J [2004]. Microbiological tests for equipment, containers, water, and air. In: Wehr HM, Frank JF, eds. *Standard methods for the examination of dairy products*. Washington, DC: American Public Health Association.

Eduard W [2009]. Fungal spores: a critical review of the toxicological and epidemiological evidence as a basis for occupational exposure limit setting. *Crit Rev Toxicol* 39(10):799-864.

Eduard W, Heederik D, Duchaine C, Green BJ [2012]. Bioaerosol exposure assessment in the workplace: the past, present and recent advances. *J Environ Monit* 14(2):334-339.

Eduard W, Lacey J, Karlsson K, Palmgren U, Strom G, Blomquist G [1990]. Evaluation of methods for enumerating microorganisms in filter samples from highly contaminated occupational environments. *Am Ind Hyg Assoc J* 51(8):427-436.

Environment Agency [2009]. Review of methods to measure bioaerosols from composting sites. Science report: SC040021/SR3. Bristol, UK: Environment Agency.

Fabian P, McDevitt JJ, Houseman EA, Milton DK [2009]. Airborne influenza virus detection with four aerosol samplers using molecular and infectivity assays: considerations for a new infectious virus aerosol sampler. *Indoor Air* 19(5):433-441.



Farnsworth JE, Goyal SM, Kim SW, Kuehn TH, Raynor PC, Ramakrishnan MA, Anantharaman S, Tang W [2006]. Development of a method for bacteria and virus recovery from heating, ventilation, and air conditioning (HVAC) filters. *J Environ Monit* 8(10):1006-1013.

Ferro AR, Kopperud RJ, Hildemann LM [2004]. Source strengths for indoor human activities that resuspend particulate matter. *Environ Sci Technol* 38(6):1759-1764.

Fields BN, Knipe DM, Howley PM [2007]. *Fields virology*. Philadelphia: Lippincott, Williams & Wilkins.

Fields BS [2002]. Legionellae and Legionnaires' disease. In: Hurst CJ, Crawford RL, McInerney MJ, Knudsen GR, Stetzenbach LD, eds. *Manual of environmental microbiology*. Washington, DC: ASM Press.

Filep S, Tsay A, Vailes L, Gadermaier G, Ferreira F, Matsui E, King EM, Chapman MD [2012]. A multi-allergen standard for the calibration of immunoassays: CREATE principles applied to eight purified allergens. *Allergy* 67(2):235-241.

Fisher EM, Richardson AW, Harpest SD, Hofacre KC, Shaffer RE [2012]. Reaerosolization of MS2 bacteriophage from an N95 filtering facepiece respirator by simulated coughing. *Ann Occup Hyg* 56(3):315-325.

Flannigan B, Samson RA, Miller JD [2011]. *Microorganisms in home and indoor work environments: diversity, health impacts, investigation and control*, 2nd Edition. Boca Raton, FL: CRC Press, Taylor and Francis Group.

Flint SJ, Enquist LW, Racaniello VR, Skalka AM [2009a]. *Principles of virology*, 3rd edition. Washington, DC: American Society for Microbiology.

Flint JS, Enquist LW, Shalka AM [2009b]. Virological methods. In: *Principles of virology*, 3rd edition. Washington, DC: American Society for Microbiology.

Frankel M, Timm M, Hansen EW, Madsen AM [2012]. Comparison of sampling methods for the assessment of indoor microbial exposure. *Indoor Air* 22(5):405-414.

Frenz DA [1999]. Comparing pollen and spore counts collected with the Rotorod Sampler and Burkard spore trap. *Ann Allergy Asthma Immunol* 83(5):341-347; quiz 348-349.



Friberg B, Friberg S, Burman LG [1999]. Inconsistent correlation between aerobic bacterial surface and air counts in operating rooms with ultra clean laminar air flows: proposal of a new bacteriological standard for surface contamination. *J Hosp Infect* 42(4):287-293.

Fronczek CF, Yoon JY [2015]. Biosensors for monitoring airborne pathogens. *J Lab Autom* 20(4):390-410.

Garvey JS, Campbell DH, Cremer NE, Sussdorf DH [1977]. *Methods in immunology: a laboratory text for instruction and research*. Reading, MA: W. A. Benjamin.

Gordon J, Gandhi P, Shekhawat G, Frazier A, Hampton-Marcell J, Gilbert JA [2015]. A simple novel device for air sampling by electrokinetic capture. *Microbiome* 3:79.

Gore RB, Hadi EA, Craven M, Smillie FI, O'Meara TJ, Tovey ER, Woodcock A, Custovic A [2002]. Personal exposure to house dust mite allergen in bed: nasal air sampling and reservoir allergen levels. *Clin Exp Allergy* 32(6):856-859.

Görner P, Fabriès JF, Duquenne P, Witschger O, Wrobel R [2006]. Bioaerosol sampling by a personal rotating cup sampler CIP 10-M. *J Environ Monit* 8(1):43-48.

Gorny RL, Dutkiewicz J, Krysinska-Traczyk E [1999]. Size distribution of bacterial and fungal bioaerosols in indoor air. *Ann Agric Environ Med* 6(2):105-113.

Goyal SM, Anantharaman S, Ramakrishnan MA, Sajja S, Kim SW, Stanley NJ, Farnsworth JE, Kuehn TH, Raynor PC [2011]. Detection of viruses in used ventilation filters from two large public buildings. *Am J Infect Control* 39(7):e30-38.

Graham JA, Pavlicek PK, Sercombe JK, Xavier ML, Tovey ER [2000]. The nasal air sampler: a device for sampling inhaled aeroallergens. *Ann Allergy Asthma Immunol* 84(6):599-604.

Gralton J, Tovey ER, McLaws ML, Rawlinson WD [2013]. Respiratory virus RNA is detectable in airborne and droplet particles. *J Med Virol* 85(12):2151-2159.

Green BJ, Millechia L, Blachere FM, Tovey ER, Beezhold DH, Schmechel D [2006a]. Dual fluorescent halogen immunoassay for bioaerosols using confocal microscopy. *Anal Biochem* 354(1):151-153.

Green BJ, Mitakakis TZ, Tovey ER [2003]. Allergen detection from 11 fungal species before and after germination. *J Allergy Clin Immunol* 111(2):285-289.



Green BJ, Schmechel D, Sercombe JK, Tovey ER [2005a]. Enumeration and detection of aerosolized *Aspergillus fumigatus* and *Penicillium chrysogenum* conidia and hyphae using a novel double immunostaining technique. *J Immunol Methods* 307(1-2):127-134.

Green BJ, Schmechel D, Summerbell RC [2011]. Aerosolized fungal fragments. In: Adnan O, Samson RA, eds. *Fundamentals of mold growth in indoor environments and strategies for healthy living*. Amsterdam, Netherlands: Wageningen Academic Publishers.

Green BJ, Schmechel D, Tovey ER [2005b]. Detection of *Alternaria alternata* conidia and hyphae using a novel double immunostaining technique. *Clin Diagn Lab Immunol* 12(9):1114-1116.

Green BJ, Sercombe JK, Tovey ER [2005c]. Fungal fragments and undocumented conidia function as new aeroallergen sources. *J Allergy Clin Immunol* 115(5):1043-1048.

Green BJ, Tovey ER, Sercombe JK, Blachere FM, Beezhold DH, Schmechel D [2006b]. Airborne fungal fragments and allergenicity. *Med Mycol* 44:S245-S255.

Green BJ, Yli-Panula E, Tovey ER [2006c]. Halogen immunoassay, a new method for the detection of sensitization to fungal allergens; comparisons with conventional techniques. *Allergol Int* 55(2):131-139.

Greenberg AE, Clesceri LS, Eaton AD [1992]. *Standard methods for the examination of water and wastewater*. Washington, DC: American Public Health Association.

Greenburg L [1932]. The Greenburg-Smith impinger sampling apparatus for dusts, fumes, smoke, and gases. *Am J Public Health* 22(10):1077-1082.

Grinshpun SA, Willeke K, Ulevicius V, Juozaitis A, Terzieva S, Donnelly J, Stelma GN, Brenner KP [1997]. Effect of impaction, bounce and reaerosolization on the collection efficiency of impingers. *Aerosol Sci Technol* 26(4):326-342.

Gustin KM, Belser JA, Wadford DA, Pearce MB, Katz JM, Tumpey TM, Maines TR [2011]. Influenza virus aerosol exposure and analytical system for ferrets. *Proc Natl Acad Sci USA* 108(20):8432-8437.

Haaland D, Siegel JA [2016]. Quantitative filter forensics for indoor particle sampling. *Indoor Air*, DOI:10.1111/ina.12319.



Haghani I, Shokohi T, Hajheidari Z, Khalilian A, Aghili SR [2013]. Comparison of diagnostic methods in the evaluation of onychomycosis. *Mycopathologia* 175(3-4):315-321.

Haig CW, Mackay WG, Walker JT, Williams C [2016]. Bioaerosol sampling: sampling mechanisms, bioefficiency and field studies. *J Hosp Infect* 95:242-245

Hairston PP, Ho J, Quant FR [1997]. Design of an instrument for real-time detection of bioaerosols using simultaneous measurement of particle aerodynamic size and intrinsic fluorescence. *J Aerosol Sci* 28(3):471-482.

Han T, Fennell D, Mainelis G [2015]. Development and optimization of the electrostatic precipitator with superhydrophobic surface (EPSS) Mark II for collection of bioaerosols. *Aerosol Sci Technol* 49(4):210-219.

Han T, Mainelis G [2012]. Investigation of inherent and latent internal losses in liquid-based bioaerosol samplers. *J Aerosol Sci* 45:58-68.

Harper GJ [1961]. Airborne micro-organisms: survival tests with four viruses. *J Hyg (Lond)* 59:479-486.

Hatch MT, Warren JC [1969]. Enhanced recovery of airborne T3 coliphage and *Pasteurella pestis* bacteriophage by means of a presampling humidification technique. *Appl Microbiol* 17(5):685-689.

Heederik D [2013]. Potential public health consequences of exposure assessment for *Staphylococcus aureus*: commentary on the paper by Masclaux et al. *Ann Occup Hyg* 57(5):545-549.

Heitkamp MA, McKinsey PC, Bagwell CE, Eakle R, Lindler LE, Fernandez-Prada C [2006]. Feasibility of the Aerosol-to-Liquid Particle Extraction System (ALPES) for collection of viable *Francisella* sp. Savannah, GA: Savannah River National Laboratory, <http://sti.srs.gov/fulltext/2006/TR2006281.pdf>.

Henningson EW, Ahlberg MS [1994]. Evaluation of microbiological aerosol samplers. A review. *J Aerosol Sci* 25(8):1459-1459.

Henningson EW, Fångmark I, Larsson E, Wikström LE [1988]. Collection efficiency of liquid samplers for microbiological aerosols. *J Aerosol Sci* 19(7):911-914.



Hering SV [2001]. Impactors, cyclones, and other particle collectors. In: Cohen BS, McCammon CS Jr., eds. Air sampling instruments for evaluation of atmospheric contaminants. Cincinnati, OH: American Conference of Governmental Industrial Hygienists.

Hinds WC [1999]. Aerosol technology. Properties, behavior, and measurement of airborne particles. New York: John Wiley & Sons.

Hirst JM [1952]. An automatic volumetric spore-trap. *Ann Appl Biol* 39:257-265.

Ho J, Spence M, Duncan S [2005]. An approach towards characterizing a reference sampler for culturable biological particle measurement. *J Aerosol Sci* 36(5-6):557-573.

Hocking AD, Pitt JI [1980]. Dichloran-glycerol medium for enumeration of xerophilic fungi from low-moisture foods. *Appl Environ Microbiol* 39(3):488-492.

Hodges LR, Rose LJ, O'Connell H, Arduino MJ [2010]. National validation study of a swab protocol for the recovery of *Bacillus anthracis* spores from surfaces. *J Microbiol Methods* 81(2):141-146.

Hodges LR, Rose LJ, Peterson A, Noble-Wang J, Arduino MJ [2006]. Evaluation of a macrofoam swab protocol for the recovery of *Bacillus anthracis* spores from a steel surface. *Appl Environ Microbiol* 72(6):4429-4430.

Hogan CJ Jr., Kettleson EM, Lee MH, Ramaswami B, Angenent LT, Biswas P [2005]. Sampling methodologies and dosage assessment techniques for submicrometre and ultrafine virus aerosol particles. *J Appl Microbiol* 99(6):1422-1434.

Holmgren H, Bake B, Olin AC, Ljungstrom E [2011]. Relation between humidity and size of exhaled particles. *J Aerosol Med Pulm Drug Deliv* 24(5):253-260.

Hook-Barnard I, Norris SMP, Alper J [2014]. Technologies to enable autonomous detection for BioWatch: ensuring timely and accurate information for public health officials: workshop summary. Washington DC: Institute of Medicine.

HUD [2008]. Vacuum dust sample collection protocol for allergens. Washington, DC: Department of Housing and Urban Development, http://portal.hud.gov/hudportal/documents/huddoc?id=DOC_12539.pdf.



- Hung LL, Miller JD, Dillon HK [2005]. Field guide for the determination of biological contaminants in environmental samples. Fairfax, VA: American Industrial Hygiene Association.
- Hunter CA, Grant C, Flannigan B, Bravery AF [1988]. Mould in buildings: the air spora of domestic dwellings. *Int Biodeterior* 24(2):81-101.
- Hussein T, Norros V, Hakala J, Petaja T, Aalto PP, Rannik U, Vesala T, Ovaskainen O [2013]. Species traits and inertial deposition of fungal spores. *J Aerosol Sci* 61(0):81-98.
- Huttunen K, Tirkkonen J, Taubel M, Krop E, Mikkonen S, Pekkanen J, Heederik D, Zock JP, Hyvarinen A, Hirvonen MR [2016]. Inflammatory potential in relation to the microbial content of settled dust samples collected from moisture-damaged and reference schools: results of HITEA study. *Indoor Air* 26(3):380-390.
- Hyvarinen A, Vahteristo M, Meklin T, Jantunen M, Nevalainen A, Moschandreas D [2001]. Temporal and spatial variation of fungal concentrations in indoor air. *Aerosol Sci Technol* 35(2):688-695.
- Ibach MJ, Larsh HW, Furcolow ML [1954]. Isolation of *Histoplasma capsulatum* from the air. *Science* 119(3080):71.
- Ijaz MK, Brunner AH, Sattar SA, Nair RC, Johnson-Lussenburg CM [1985a]. Survival characteristics of airborne human coronavirus 229E. *J Gen Virol* 66(Pt 12):2743-2748.
- Ijaz MK, Sattar SA, Johnson-Lussenburg CM, Springthorpe VS, Nair RC [1985b]. Effect of relative humidity, atmospheric temperature, and suspending medium on the airborne survival of human rotavirus. *Can J Microbiol* 31(8):681-685.
- Ijaz MK, Zargar B, Wright KE, Rubino JR, Sattar SA [2016]. Generic aspects of the airborne spread of human pathogens indoors and emerging air decontamination technologies. *Am J Infect Control* 44(9 Suppl):S109-120.
- IOM [2004]. Damp indoor spaces and health. Washington, DC: Institute of Medicine.
- ISO [2003]. ISO 14698:2003 Cleanrooms and associated controlled environments -- Biocontamination control. Geneva, Switzerland: International Organization for Standardization.



ISO [2012]. ISO 13138:2012 Air quality -- Sampling conventions for airborne particle deposition in the human respiratory system. Geneva, Switzerland: International Organization for Standardization.

Jacobs RR [1989]. Airborne endotoxins: an association with occupational lung disease. *Appl Ind Hyg* 4(2):50-56.

Jensen PA, Todd WF, Davis GN, Scarpino PV [1992]. Evaluation of eight bioaerosol samplers challenged with aerosols of free bacteria. *Am Ind Hyg Assoc J* 53(10):660-667.

Johansson E, Reponen T, Meller J, Vesper S, Yadav J [2014]. Association of *Streptomyces* community composition determined by PCR-denaturing gradient gel electrophoresis with indoor mold status. *Environ Monit Assess* 186(12):8773-8783.

Johnson FB [1990]. Transport of viral specimens. *Clin Microbiol Rev* 3(2):120-131.

Johnston AM, Vincent JH, Jones AD [1985]. Measurements of electric charge for workplace aerosols. *Ann Occup Hyg* 29(2):271-284.

Jones RM, Brosseau LM [2015]. Aerosol transmission of infectious disease. *J Occup Environ Med* 57(5):501-508.

Jonges M, van Leuken J, Wouters I, Koch G, Meijer A, Koopmans M [2015]. Wind-mediated spread of low-pathogenic avian influenza virus into the environment during outbreaks at commercial poultry farms. *PLoS ONE* 10(5):e0125401.

Julian TR, Tamayo FJ, Leckie JO, Boehm AB [2011]. Comparison of surface sampling methods for virus recovery from fomites. *Appl Environ Microbiol* 77(19):6918-6925.

Kanaani H, Hargreaves M, Smith J, Ristovski Z, Agranovski V, Morawska L [2008]. Performance of UVAPS with respect to detection of airborne fungi. *J Aerosol Sci* 39(2):175-189.

Karim YG, Ijaz MK, Sattar SA, Johnson-Lussenburg CM [1985]. Effect of relative humidity on the airborne survival of rhinovirus-14. *Can J Microbiol* 31(11):1058-1061.

Karlsson K, Malmberg P [1989]. Characterization of exposure to molds and actinomycetes in agricultural dusts by scanning electron microscopy, fluorescence microscopy and the culture method. *Scand J Work Environ Health* 15(5):353-359.



Kendrick B [2000]. *The fifth kingdom*, 3rd Edition. Newburyport, MA: Focus Publishing, R. Pullins Company.

Kenny LC, Aitken R, Chalmers C, Fabries JF, Gonzalez-Fernandez E, Kromhout H, Liden G, Mark D, Riediger G, Prodi V [1997]. A collaborative European study of personal inhalable aerosol sampler performance. *Ann Occup Hyg* 41(2):135-153.

Kesavan J, Sagripanti JL [2015]. Evaluation criteria for bioaerosol samplers. *Environ Sci Process Impacts* 17(3):638-645.

Kesavan J, Schepers D, McFarland AR [2010]. Sampling and retention efficiencies of batch-type liquid-based bioaerosol samplers. *Aerosol Sci Technol* 44(10):817-829.

Kesavan JS, Schepers D, Bottiger J [2011]. Characteristics of twenty-nine aerosol samplers tested at U.S. Army Edgewood Chemical Biological Center (2000 - 2006). Aberdeen Proving Ground, MD: U.S. Army, <http://www.dtic.mil/dtic/tr/fulltext/u2/a540009.pdf>.

Kettleson E, Kumar S, Reponen T, Vesper S, Meheust D, Grinshpun SA, Adhikari A [2013]. *Stenotrophomonas*, *Mycobacterium*, and *Streptomyces* in home dust and air: associations with moldiness and other home/family characteristics. *Indoor Air* 23(5):387-396.

Kettleson EM, Adhikari A, Vesper S, Coombs K, Indugula R, Reponen T [2015]. Key determinants of the fungal and bacterial microbiomes in homes. *Environ Res* 138:130-135.

Kilburg-Basnyat B, Metwali N, Thorne PS [2016]. Performance of electrostatic dust collectors (EDCs) for endotoxin assessment in homes: effect of mailing, placement, heating, and electrostatic charge. *J Occup Environ Hyg* 13(2):85-93.

Kilburg-Basnyat B, Peters TM, Perry SS, Thorne PS [2015]. Electrostatic dust collectors compared to inhalable samplers for measuring endotoxin concentrations in farm homes. *Indoor Air* 26(5):724-733.

King EM, Filep S, Smith B, Platts-Mills T, Hamilton RG, Schmechel D, Sordillo JE, Milton D, van Ree R, Krop EJ, Heederik DJ, Metwali N, Thorne PS, Zeldin DC, Sever ML, Calatroni A, Arbes SJ Jr., Mitchell HE, Chapman MD [2013]. A multi-center ring trial of allergen analysis using fluorescent multiplex array technology. *J Immunol Methods* 387(1-2):89-95.

Kissell FN, Sacks HK [2002]. Inaccuracy of area sampling for measuring the dust exposure of mining machine operators in coal mines. *Mining Eng* 54(2):33-39.



Koncsag CI, Barbulescu A [2011]. Liquid-liquid extraction with and without a chemical reaction. In: El-Amin M, ed. Mass transfer in multiphase systems and its applications. Rijeka, Croatia: InTech. DOI: 10.5772/594.

Koneman EW [1988]. Color atlas and textbook of diagnostic microbiology. Philadelphia: Lippincott.

Kujundzic E, Hernandez M, Miller SL [2006]. Particle size distributions and concentrations of airborne endotoxin using novel collection methods in homes during the winter and summer seasons. *Indoor Air* 16(3):216-226.

Kuo Y-M [2015]. Field evaluation of sampling bias with plastic petri dishes for size-fractionated bioaerosol sampling. *Aerosol Sci Technol* 49(3):127-133.

Lacey J, Crook B [1988]. Fungal and actinomycete spores as pollutants of the workplace and occupational allergens. *Ann Occup Hyg* 32(4):515-533.

LeBouf R, Yesse L, Rossner A [2008]. Seasonal and diurnal variability in airborne mold from an indoor residential environment in Northern New York. *J Air Waste Manag Assoc* 58(5):684-692.

Lednický J, Pan M, Loeb J, Hsieh H, Eiguren-Fernandez A, Hering S, Fan ZH, Wu C-Y [2016]. Highly efficient collection of infectious pandemic influenza H1N1 virus (2009) through laminar-flow water based condensation. *Aerosol Sci Technol* 50(7):i-iv.

Lee KS, Bartlett KH, Brauer M, Stephens GM, Black WA, Teschke K [2004a]. A field comparison of four samplers for enumerating fungal aerosols I. Sampling characteristics. *Indoor Air* 14(5):360-366.

Lee SA, Adhikari A, Grinshpun SA, McKay R, Shukla R, Reponen T [2006]. Personal exposure to airborne dust and microorganisms in agricultural environments. *J Occup Environ Hyg* 3(3):118-130.

Lee SA, Liao CH [2014]. Size-selective assessment of agricultural workers' personal exposure to airborne fungi and fungal fragments. *Sci Total Environ* 466-467:725-732.

Lee SA, Willeke K, Mainelis G, Adhikari A, Wang H, Reponen T, Grinshpun SA [2004b]. Assessment of electrical charge on airborne microorganisms by a new bioaerosol sampling method. *J Occup Environ Hyg* 1(3):127-138.



Leland DS, Emanuel D [1995]. Laboratory diagnosis of viral infections of the lung. *Semin Respir Infect* 10(4):189-198.

Leland DS, Ginocchio CC [2007]. Role of cell culture for virus detection in the age of technology. *Clin Microbiol Rev* 20(1):49-78.

Lembke LL, Kniseley RN, van Nostrand RC, Hale MD [1981]. Precision of the all-glass impinger and the Andersen microbial impactor for air sampling in solid-waste handling facilities. *Appl Environ Microbiol* 42(2):222-225.

Leopold SS [1988]. "Positive hole" statistical adjustment for a two-stage, 200-hole-per-stage Andersen air sampler. *Am Ind Hyg Assoc J* 49(2):A88-A90.

Life Technologies [2014]. Real-time PCR handbook. Waltham, MA: Thermo Fisher Scientific, <http://www.thermofisher.com/us/en/home/life-science/pcr/real-time-pcr/qpcr-education.html>.

Lin X, Willeke K, Ulevicius V, Grinshpun SA [1997]. Effect of sampling time on the collection efficiency of all-glass impingers. *Am Ind Hyg Assoc J* 58(7):480-488.

Lin XJ, Reponen T, Willeke K, Wang Z, Grinshpun SA, Trunov M [2000]. Survival of airborne microorganisms during swirling aerosol collection. *Aerosol Sci Technol* 32(3):184-196.

Lindsley WG, Blachere FM, Davis KA, Pearce TA, Fisher MA, Khakoo R, Davis SM, Rogers ME, Thewlis RE, Posada JA, Redrow JB, Celik IB, Chen BT, Beezhold DH [2010a]. Distribution of airborne influenza virus and respiratory syncytial virus in an urgent care medical clinic. *Clin Infect Dis* 50(5):693-698.

Lindsley WG, Blachere FM, Thewlis RE, Vishnu A, Davis KA, Cao G, Palmer JE, Clark KE, Fisher MA, Khakoo R, Beezhold DH [2010b]. Measurements of airborne influenza virus in aerosol particles from human coughs. *PLoS ONE* 5(11):e15100.

Lioy PJ, Freeman NC, Millette JR [2002]. Dust: a metric for use in residential and building exposure assessment and source characterization. *Environ Health Perspect* 110(10):969-983.

Liu BYH, Pui DYH, Rubow KL, Szymanski WW [1985]. Electrostatic effects in aerosol sampling and filtration. *Aerosol Sci Technol* 4(3):249-268.



Lowen AC, Mubareka S, Steel J, Palese P [2007]. Influenza virus transmission is dependent on relative humidity and temperature. *PLoS Pathog* 3(10):1470-1476.

Lowen AC, Steel J, Mubareka S, Palese P [2008]. High temperature (30 degrees C) blocks aerosol but not contact transmission of influenza virus. *J Virol* 82(11):5650-5652.

Macher JM [1989]. Positive-hole correction of multiple-jet impactors for collecting viable microorganisms. *Am Ind Hyg Assoc J* 50(11):561-568.

Macher JM [1999]. *Bioaerosols: assessment and control*. Cincinnati, OH: American Conference of Governmental Industrial Hygienists.

Macher JM, Chatigny MA, Burge HA [1995]. Sampling airborne microorganisms and aeroallergens. In: Cohen BS, Hering SV, eds. *Air sampling instruments for evaluation of atmospheric contaminants*. Cincinnati, OH: American Conference of Governmental Industrial Hygienists.

Macher JM, First MW [1984]. Personal air samplers for measuring occupational exposures to biological hazards. *Am Ind Hyg Assoc J* 45(2):76-83.

Macher JM, Hansson HC [1987]. Personal size-separating impactor for sampling microbiological aerosols. *Am Ind Hyg Assoc J* 48(7):652-655.

Madeley CR, Peiris JS [2002]. Methods in virus diagnosis: immunofluorescence revisited. *J Clin Virol* 25(2):121-134.

Madelin TM, Johnson HE [1992]. Fungal and actinomycete spore aerosols measured at different humidities with an aerodynamic particle sizer. *J Appl Bacteriol* 72(5):400-409.

Mahony JB [2008]. Detection of respiratory viruses by molecular methods. *Clin Microbiol Rev* 21(4):716-747.

Mainelis G, Gorny RL, Reponen T, Trunov M, Grinshpun SA, Baron P, Yadav J, Willeke K [2002]. Effect of electrical charges and fields on injury and viability of airborne bacteria. *Biotechnol Bioeng* 79(2):229-241.

Marple VA, Olson BA [2011]. Sampling and measurement using inertial, gravitational, centrifugal, and thermal techniques. In: Kulkarni P, Baron PA, Willeke K, eds. *Aerosol measurement: principles, techniques, and applications*. Hoboken, NJ: John Wiley & Sons.



Marple VA, Willeke K [1976]. Inertial impactors: theory, design and use. In: Liu BYH, ed. *Fine particles: aerosol generation, measurement, sampling and analysis*. New York: Academic Press.

Martin E, Dziurawitz N, Jackel U, Schafer J [2015]. Detection of airborne bacteria in a duck production facility with two different personal air sampling devices for an exposure assessment. *J Occup Environ Hyg* 12(2):77-86.

Martyny JW, Martinez KF, Morey PR [1999]. Source Sampling. In: Macher J, ed. *Bioaerosols: assessment and control*. Cincinnati, OH: American Conference of Governmental Industrial Hygienists.

Masclaux FG, Hotz P, Gashi D, Savova-Bianchi D, Oppliger A [2014]. Assessment of airborne virus contamination in wastewater treatment plants. *Environ Res* 133:260-265.

May KR [1966]. Multistage liquid impinger. *Bacteriol Rev* 30(3):559-570.

May KR, Harper GJ [1957]. The efficiency of various liquid impinger samplers in bacterial aerosols. *Br J Ind Med* 14(4):287-297.

McDevitt JJ, Koutrakis P, Ferguson ST, Wolfson JM, Fabian MP, Martins M, Pantelic J, Milton DK [2013]. Development and performance evaluation of an exhaled-breath bioaerosol collector for influenza virus. *Aerosol Sci Technol* 47(4):444-451.

Meadow JF, Altrichter AE, Bateman AC, Stenson J, Brown GZ, Green JL, Bohannon BJ [2015]. Humans differ in their personal microbial cloud. *PeerJ* 3:e1258.

Meklin T, Reponen T, Toivola M, Koponen V, Husman T, Hyvarinen A, Nevalainen A [2002]. Size distributions of airborne microbes in moisture-damaged and reference school buildings of two construction types. *Atmos Environ* 36(39-40):6031-6039.

Mendell MJ, Mirer AG, Cheung K, Tong M, Douwes J [2011]. Respiratory and allergic health effects of dampness, mold, and dampness-related agents: a review of the epidemiologic evidence. *Environ Health Perspect* 119:748-756.

Mikhailov E, Vlasenko S, Niessner R, Pöschl U [2004]. Interaction of aerosol particles composed of protein and salts with water vapor: hygroscopic growth and microstructural rearrangement. *Atmos Chem Phys* 4(2):323-350.



- Milton DK, Fabian MP, Cowling BJ, Grantham ML, McDevitt JJ [2013]. Influenza virus aerosols in human exhaled breath: particle size, culturability, and effect of surgical masks. *PLoS Pathog* 9(3):e1003205.
- Milton DK, Gere RJ, Feldman HA, Greaves IA [1990]. Endotoxin measurement: aerosol sampling and application of a new *Limulus* method. *Am Ind Hyg Assoc J* 51(6):331-337.
- Mitakakis TZ, Barnes C, Tovey ER [2001]. Spore germination increases allergen release from *Alternaria*. *J Allergy Clin Immunol* 107(2):388-390.
- Mitakakis TZ, O'Meara TJ, Tovey ER [2003]. The effect of sunlight on allergen release from spores of the fungus *Alternaria*. *Grana* 42(1):43-46.
- Mitakakis TZ, Tovey ER, Xuan W, Marks GB [2000]. Personal exposure to allergenic pollen and mould spores in inland New South Wales, Australia. *Clin Exp Allergy* 30(12):1733-1739.
- Moore G, Griffith C [2007]. Problems associated with traditional hygiene swabbing: the need for in-house standardization. *J Appl Microbiol* 103(4):1090-1103.
- Morey P, Otten J, Burge H, Chatigny M, Feeley J, LaForce FM, Peterson K [1986]. Airborne viable microorganisms in office environments: sampling protocol and analytical procedures. *Appl Ind Hyg* 1:R19-R23.
- Morey PR [2007]. Microbiological sampling strategies in indoor environments. In: *Sampling and analysis of indoor microorganisms*. Hoboken, NJ: John Wiley & Sons, Inc.
- Murray BK, Ohmine S, Tomer DP, Jensen KJ, Johnson FB, Kirsi JJ, Robison RA, O'Neill KL [2008]. Virion disruption by ozone-mediated reactive oxygen species. *J Virol Methods* 153(1):74-77.
- Nardell EA [2016]. Indoor environmental control of tuberculosis and other airborne infections. *Indoor Air* 26(1):79-87.
- Nazaroff WW [2016]. Indoor bioaerosol dynamics. *Indoor Air* 26(1):61-78.
- Nevalainen A [1989]. Bacterial aerosols in indoor air. Thesis. Helsinki, Finland: National Public Health Institute.



Nevalainen A, Taubel M, Hyvarinen A [2015]. Indoor fungi: companions and contaminants. *Indoor Air* 25(2):125-156.

Nicas M, Nazaroff WW, Hubbard A [2005]. Toward understanding the risk of secondary airborne infection: emission of respirable pathogens. *J Occup Environ Hyg* 2(3):143-154.

NIOSH [2003a]. Aerosol sampling: minimizing particle loss from cassette bypass leakage. By Baron PA. In: Schlecht PC, O'Connor PF, eds. *NIOSH Manual of Analytical Methods*, 4th edition. Cincinnati, OH: U.S. Department of Health and Human Services, Centers for Disease Control and Prevention, National Institute for Occupational Safety and Health, DHHS (NIOSH) Publication No. 2003-154, <http://www.cdc.gov/niosh/nmam>.

NIOSH [2003b]. Method 0800 Bioaerosol sampling (indoor air). In: Schlecht PC, O'Connor PF, eds. *NIOSH Manual of Analytical Methods*, 4th edition. Cincinnati, OH: U.S. Department of Health and Human Services, Centers for Disease Control and Prevention, National Institute for Occupational Safety and Health, DHHS (NIOSH) Publication No. 2003-154, <http://www.cdc.gov/niosh/nmam>.

NIOSH [2003c]. Method 0600 Particulates not otherwise regulated, respirable. In: Schlecht PC, O'Connor PF, eds. *NIOSH Manual of Analytical Methods*, 4th edition. Cincinnati, OH: U.S. Department of Health and Human Services, Centers for Disease Control and Prevention, National Institute for Occupational Safety and Health, DHHS (NIOSH) Publication No. 2003-154, <http://www.cdc.gov/niosh/nmam>.

NIOSH [2003d]. Method 2549 Volatile organic compounds (screening). In: Schlecht PC, O'Connor PF, eds. *NIOSH Manual of Analytical Methods*, 4th edition. Cincinnati, OH: U.S. Department of Health and Human Services, Centers for Disease Control and Prevention, National Institute for Occupational Safety and Health, DHHS (NIOSH) Publication No. 2003-154, <http://www.cdc.gov/niosh/nmam>.

NIOSH [2003e]. *NIOSH Manual of Analytical Methods*, 4th edition. Schlecht PC, O'Connor PF, eds. Cincinnati, OH: U.S. Department of Health and Human Services, Centers for Disease Control and Prevention, National Institute for Occupational Safety and Health, DHHS (NIOSH) Publication No. 2003-154, <http://www.cdc.gov/niosh/nmam>.

NIOSH [2010]. *NIOSH Pocket Guide to Chemical Hazards*. Cincinnati, OH: U.S. Department of Health and Human Services, Centers for Disease Control and Prevention, National Institute for Occupational Safety and Health, <http://www.cdc.gov/niosh/npg/>.



NIOSH [2012a] Preventing occupational respiratory disease from exposures caused by dampness in office buildings, schools, and other nonindustrial buildings. Morgantown, WV: U.S. Department of Health and Human Services, Centers for Disease Control and Prevention, National Institute for Occupational Safety and Health, DHHS (NIOSH) Publication No. 2013-102, <http://www.cdc.gov/niosh/docs/2013-102/pdfs/2013-102.pdf>.

NIOSH [2012b]. Surface sampling procedures for *Bacillus anthracis* spores from smooth, non-porous surfaces. Washington, D.C.: U.S. Department of Health and Human Services, Centers for Disease Control and Prevention, National Institute for Occupational Safety and Health, <http://www.cdc.gov/niosh/topics/emres/surface-sampling-bacillus-anthraxis.html>.

NIOSH [2016a]. Factors affecting aerosol sampling. By Baron PA. In: Ashley K, O'Connor PF, eds. NIOSH Manual of Analytical Methods, 5th edition. Cincinnati, OH: U.S. Department of Health and Human Services, Centers for Disease Control and Prevention, National Institute for Occupational Safety and Health, DHHS (NIOSH) Publication No. 2014-151, <http://www.cdc.gov/niosh/nmam>.

NIOSH [2016b]. Filter pore size and aerosol sample collection. By Lindsley WG. In: Ashley K, O'Connor PF, eds. NIOSH Manual of Analytical Methods, 5th edition. Cincinnati, OH: U.S. Department of Health and Human Services, Centers for Disease Control and Prevention, National Institute for Occupational Safety and Health, DHHS (NIOSH) Publication No. 2014-151, <http://www.cdc.gov/niosh/nmam>.

NIOSH [2016c]. General considerations for sampling airborne contaminants. By McCammon CS Jr., Woebkenberg ML. In: Ashley K, O'Connor PF, eds. NIOSH Manual of Analytical Methods, 5th edition. Cincinnati, OH: U.S. Department of Health and Human Services, Centers for Disease Control and Prevention, National Institute for Occupational Safety and Health, DHHS (NIOSH) Publication No. 2014-151, <http://www.cdc.gov/niosh/nmam>.

Noris F, Siegel JA, Kinney KA [2011]. Evaluation of HVAC filters as a sampling mechanism for indoor microbial communities. *Atmos Environ* 45(2):338-346.

Noss I, Doekes G, Sander I, Heederik DJ, Thorne PS, Wouters IM [2010]. Passive airborne dust sampling with the electrostatic dustfall collector: optimization of storage and extraction procedures for endotoxin and glucan measurement. *Ann Occup Hyg* 54(6):651-658.

Noss I, Wouters IM, Visser M, Heederik DJ, Thorne PS, Brunekreef B, Doekes G [2008]. Evaluation of a low-cost electrostatic dust fall collector for indoor air endotoxin exposure assessment. *Appl Environ Microbiol* 74(18):5621-5627.

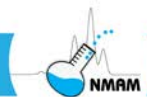

Noti JD, Blachere FM, McMillen CM, Lindsley WG, Kashon ML, Slaughter DR, Beezhold DH [2013]. High humidity leads to loss of infectious influenza virus from simulated coughs. *PLoS ONE* 8(2):e57485.

Olenchock SA [2002]. Airborne endotoxin. In: Hurst CJ, Crawford RL, McInerney MJ, Knudsen GR, Stetzenbach LD, eds. *Manual of environmental microbiology*. Washington, DC: ASM Press.

Olenchock SA, Mull JC, Jones WG [1983]. Endotoxins in cotton: washing effects and size distribution. *Am J Ind Med* 4(4):515-521.

Otten JA, Morey PR, Burge HA, Chatigny MA, Feeley JC, Peterson K [1986]. Airborne viable microorganisms in office environments: sampling protocol and analytical procedures. *Proceedings of the 1986 EPA/APCA Symposium on Measurement of Toxic Air Pollutants*, Raleigh, NC: U.S. Environmental Protection Agency and Air Pollution Control Association.

Pan M, Eiguren-Fernandez A, Hsieh H, Afshar-Mohajer N, Hering SV, Lednicky J, Hugh Fan Z, Wu CY [2016]. Efficient collection of viable virus aerosol through laminar-flow, water-based condensational particle growth. *J Appl Microbiol* 120(3):805-815.

Pardon G, Ladhani L, Sandstrom N, Etori M, Lobov G, Van Der Wijngaart W [2015]. Aerosol sampling using an electrostatic precipitator integrated with a microfluidic interface. *Sens Actuators B Chem* 212:344-352.

Park GW, Lee D, Treffiletti A, Hrsak M, Shugart J, Vinje J [2015]. Evaluation of a new environmental sampling protocol for detection of human norovirus on inanimate surfaces. *Appl Environ Microbiol* 81(17):5987-5992.

Parvaneh S, Elfman L, Ahlf E, Nybom R, Elfman LH, van Hage-Hamsten M [2000]. A new method for collecting airborne allergens. *Allergy* 55(12):1148-1154.

Pasanen A-L, Yli-Pietila K, Pasanen P, Kalliokoski P, Tarhanen J [1999]. Ergosterol content in various fungal species and biocontaminated building materials. *Appl Environ Microbiol* 65(1):138-142.

Pasquarella C, Pitzurra O, Savino A [2000]. The index of microbial air contamination. *J Hosp Infect* 46(4):241-256.



Patolsky F, Zheng G, Hayden O, Lakadamyali M, Zhuang X, Lieber CM [2004]. Electrical detection of single viruses. *Proc Natl Acad Sci USA* 101(39):14017-14022.

Patolsky F, Zheng G, Lieber CM [2006]. Fabrication of silicon nanowire devices for ultrasensitive, label-free, real-time detection of biological and chemical species. *Nat Protocols* 1(4):1711-1724.

Peccia J, Werth HM, Miller S, Hernandez M [2001]. Effects of relative humidity on the ultraviolet induced inactivation of airborne bacteria. *Aerosol Sci Technol* 35(3):728-740.

Pityn PJ, Anderson J [2013]. Air sampling of mold spores by slit impactors: yield comparison. *J Environ Sci Health A Tox Hazard Subst Environ Eng* 48(12):1485-1490.

Plowman JE [2007]. The proteomics of keratin proteins. *J Chromatogr B Analyt Technol Biomed Life Sci* 849(1-2):181-189.

Pöhlker C, Huffman JA, Pöschl U [2012]. Autofluorescence of atmospheric bioaerosols - Fluorescent biomolecules and potential interferences. *Atmos Meas Tech* 5(1):37-71.

Poletti L, Pasquarella C, Pitzurra M, Savino A [1999]. Comparative efficiency of nitrocellulose membranes versus RODAC plates in microbial sampling on surfaces. *J Hosp Infect* 41(3):195-201.

Popp W, Zwick H, Rauscher H [1988]. Indirect immunofluorescent test on spore sampling preparations: a technique for diagnosis of individual mold allergies. *Stain Technol* 63(4):249-253.

Portnoy J, Landuyt J, Pacheco F, Flappan S, Simon S, Barnes C [2000]. Comparison of the Burkard and Allergenco MK-3 volumetric collectors. *Ann Allergy Asthma Immunol* 84(1):19-24.

Poulos LM, O'Meara TJ, Hamilton RG, Tovey ER [2002]. Inhaled latex allergen (Hev b 1). *J Allergy Clin Immunol* 109(4):701-706.

Poulos LM, O'Meara TJ, Sporik R, Tovey ER [1999]. Detection of inhaled Der p 1. *Clin Exp Allergy* 29(9):1232-1238.



- Prussin AJ II, Marr LC, Bibby KJ [2014]. Challenges of studying viral aerosol metagenomics and communities in comparison with bacterial and fungal aerosols. *FEMS Microbiol Lett* 357(1):1-9.
- Pui DYH, Romay-Novas F, Liu BYH [1987]. Experimental study of particle deposition in bends of circular cross section. *Aerosol Sci Technol* 7(3):301-315.
- Qian J, Hospodsky D, Yamamoto N, Nazaroff WW, Peccia J [2012]. Size-resolved emission rates of airborne bacteria and fungi in an occupied classroom. *Indoor Air* 22(4):339-351.
- Ravva SV, Hernlem BJ, Sarreal CZ, Mandrell RE [2012]. Bacterial communities in urban aerosols collected with wetted-wall cyclonic samplers and seasonal fluctuations of live and culturable airborne bacteria. *J Environ Monit* 14(2):473-481.
- Raynor PC, Leith D, Lee KW, Mukund R [2011]. Sampling and analysis using filters. In: Kulkarni P, Baron PA, Willeke K, eds. *Aerosol measurement: principles, techniques, and applications*. Hoboken, NJ: John Wiley & Sons.
- Razmovski V, O'Meara TJ, Taylor DJM, Tovey ER [2000]. A new method for simultaneous immunodetection and morphologic identification of individual sources of pollen allergens. *J Allergy Clin Immunol* 105(4):725-731.
- Reed LJ, Muench H [1938]. A simple method of estimating fifty per cent endpoints. *Am J Hyg* 27:493-497.
- Reid TM, Schafer MP [1999]. Direct detection of *Histoplasma capsulatum* in soil suspensions by two-stage PCR. *Mol Cell Probes* 13(4):269-273.
- Renstrom A [2002]. Exposure to airborne allergens: a review of sampling methods. *J Environ Monit* 4:619-622.
- Renstrom A, Karlsson AS, Tovey E [2002]. Nasal air sampling used for the assessment of occupational allergen exposure and the efficacy of respiratory protection. *Clin Exp Allergy* 32(12):1769-1775.
- Reponen T, Lockey J, Bernstein DI, Vesper SJ, Levin L, Khurana Hershey GK, Zheng S, Ryan P, Grinshpun SA, Villareal M, Lemasters G [2012]. Infant origins of childhood asthma associated with specific molds. *J Allergy Clin Immunol* 130(3):639-644.e5.

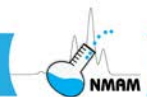

Reponen T, Seo S-C, Grimsley F, Lee T, Crawford C, Grinshpun SA [2007]. Fungal fragments in moldy houses: a field study in homes in New Orleans and Southern Ohio. *Atmos Environ* 41(37):8140-8149.

Reponen T, Vesper S, Levin L, Johansson E, Ryan P, Burkle J, Grinshpun SA, Zheng S, Bernstein DI, Lockey J, Villareal M, Khurana Hershey GK, LeMasters G [2011a]. High environmental relative moldiness index during infancy as a predictor of asthma at 7 years of age. *Ann Allergy Asthma Immunol* 107(2):120-126.

Reponen T, Willeke K, Grinshpun S, Nevalainen A [2011b]. Biological particle sampling. In: Kulkarni P, Baron PA, Willeke K, eds. *Aerosol measurement: principles, techniques, and applications*. Hoboken, NJ: John Wiley & Sons.

Reponen T, Willeke K, Ulevicius V, Reponen A, Grinshpun SA [1996]. Effect of relative humidity on the aerodynamic diameter and respiratory deposition of fungal spores. *Atmos Environ* 30(23):3967-3974.

Reponen TA, Gazenko SV, Grinshpun SA, Willeke K, Cole EC [1998]. Characteristics of airborne actinomycete spores. *Appl Environ Microbiol* 64(10):3807-3812.

Rintala H, Pitkaranta M, Taubel M [2012]. Microbial communities associated with house dust. *Adv Appl Microbiol* 78:75-120.

Rittenour WR, Ciaccio CE, Barnes CS, Kashon ML, Lemons AR, Beezhold DH, Green BJ [2014]. Internal transcribed spacer rRNA gene sequencing analysis of fungal diversity in Kansas City indoor environments. *Environ Sci Process Impacts* 16(1):33-43.

Rittenour WR, Hamilton RG, Beezhold DH, Green BJ [2012]. Immunologic, spectrophotometric and nucleic acid based methods for the detection and quantification of airborne pollen. *J Immunol Methods* 383(1-2):47-53.

Rodes CE, Thornburg JW [2005]. Breathing zone exposure assessment. In: Ruzer LS, Harley NH, Ruzer LS, Harley NH, eds. *Aerosols handbook: measurement, dosimetry, and health effects*. Boca Raton, FL: CRC Press.

Roux J-M, Kaspari O, Heinrich R, Hanschmann N, Grunow R [2013]. Investigation of a new electrostatic sampler for concentrating biological and non-biological aerosol particles. *Aerosol Sci Technol* 47(5):463-471.



- Rule AM, Chapin AR, McCarthy SA, Gibson KE, Schwab KJ, Buckley TJ [2005]. Assessment of an aerosol treatment to improve air quality in a swine concentrated animal feeding operation (CAFO). *Environ Sci Technol* 39(24):9649-9655.
- Rule AM, Kesavan J, Schwab KJ, Buckley TJ [2007]. Application of flow cytometry for the assessment of preservation and recovery efficiency of bioaerosol samplers spiked with *Pantoea agglomerans*. *Environ Sci Technol* 41(7):2467-2472.
- Ryan E, Wright C, Gloster J [2009]. Measurement of airborne foot-and-mouth disease virus: preliminary evaluation of two portable air sampling devices. *Vet J* 179(3):458-461.
- Rydjord B, Namork E, Nygaard UC, Wiker HG, Hetland G [2007]. Quantification and characterisation of IgG binding to mould spores by flow cytometry and scanning electron microscopy. *J Immunol Methods* 323:123-131.
- Rylander R, Vesterlund J [1982]. Airborne endotoxins in various occupational environments. *Prog Clin Biol Res* 93:399-409.
- Saari S, Reponen T, Keskinen J [2014]. Performance of two fluorescence-based real-time bioaerosol detectors: BioScout vs. UVAPS. *Aerosol Sci Technol* 48(4):371-378.
- Salvin SB [1949]. Cysteine and related compounds in the growth of the yeast like phase of *Histoplasma capsulatum*. *J Infect Dis* 84(3):275-283.
- Santarpia JL, Ratnesar-Shumate S, Gilberry JU, Quizon JJ [2013]. Relationship between biologically fluorescent aerosol and local meteorological conditions. *Aerosol Sci Technol* 47(6):655-661.
- Sasser M [1990a]. Identification of bacteria by gas chromatography of cellular fatty acids (Technical Note #101). Newark, DE: Microbial Identification, Inc.
- Sasser M [1990b]. Identification of bacteria through fatty acid analysis. In: Klement Z, Rudolph K, Sands DC, eds. *Methods in phytobacteriology*. Budapest, Hungary: Akadémiai Kiadó.
- Schafer MP, Fernback JE, Ernst MK [1999]. Detection and characterization of airborne mycobacterium tuberculosis H37Ra particles, a surrogate for airborne pathogenic *M. tuberculosis*. *Aerosol Sci Technol* 30(2):161-173.



Schafer MP, Fernback JE, Jensen PA [1998]. Sampling and analytical method development for qualitative assessment of airborne mycobacterial species of the *Mycobacterium tuberculosis* complex. *Am Ind Hyg Assoc J* 59(8):540-546.

Schafer MP, Martinez KF, Mathews ES [2003]. Rapid detection and determination of the aerodynamic size range of airborne mycobacteria associated with whirlpools. *Appl Occup Environ Hyg* 18(1):41-50.

Schaffer FL, Soergel ME, Straube DC [1976]. Survival of airborne influenza virus: effects of propagating host, relative humidity, and composition of spray fluids. *Arch Virol* 51(4):263-273.

Schnurer J [1993]. Comparison of methods for estimating the biomass of three food-borne fungi with different growth patterns. *Appl Environ Microbiol* 59(2):552-555.

Scott JA, Summerbell RC, Green BJ [2011]. Detection of indoor fungi bioaerosols. In: Adnan O, Samson RA, eds. *Fundamentals of mold growth in indoor environments and strategies for healthy living*. Amsterdam, Netherlands: Wageningen Academic Publishers.

Seitz LM, Sauer DB, Burroughs R, Mohr HE, Hubbard JD [1979]. Ergosterol as a measure of fungal growth. *Phytopathology* 69:1202-1203.

Seo S, Choung JT, Chen BT, Lindsley WG, Kim KY [2014]. The level of submicron fungal fragments in homes with asthmatic children. *Environ Res* 131:71-76.

Shelton BG, Kirkland KH, Flanders WD, Morris GK [2002]. Profiles of airborne fungi in buildings and outdoor environments in the United States. *Appl Environ Microbiol* 68(4):1743-1753.

Sigma-Aldrich [1998]. Bulletin 910 Guide to solid phase extraction. <http://www.sigmaaldrich.com/Graphics/Supelco/objects/4600/4538.pdf>.

Simon X, Bau S, Boivin A, Duquenne P, Witschger O, Görner P [2016]. Physical performances and kinetics of evaporation of the CIP 10-M personal sampler's rotating cup containing aqueous or viscous collection fluid. *Aerosol Sci Technol* 50(5):507-520.

Singh U, Levin L, Grinshpun SA, Schaffer C, Adhikari A, Reponen T [2011a]. Influence of home characteristics on airborne and dustborne endotoxin and beta-D-glucan. *J Environ Monit* 13(11):3246-3253.



Singh U, Reponen T, Cho KJ, Grinshpun SA, Adhikari A, Levin L, Indugula R, Green BJ [2011b]. Airborne endotoxin and beta-D-glucan in PM₁ in agricultural and home environments. *Aerosol Air Qual Res* 11(4):376-386.

Smid T, Schokkin E, Boleij JS, Heederik D [1989]. Enumeration of viable fungi in occupational environments: a comparison of samplers and media. *Am Ind Hyg Assoc J* 50(5):235-239.

Solomon WR, Burge HA, Boise JR [1980]. Exclusion of particulate allergens by window air conditioners. *J Allergy Clin Immunol* 65(4):305-308.

Soo JC, Monaghan K, Lee T, Kashon M, Harper M [2016]. Air sampling filtration media: collection efficiency for respirable size-selective sampling. *Aerosol Sci Technol* 50(1):76-87.

Sorensen CM, Gebhart J, O'Hern TJ, Rader DJ [2011]. Optical measurement techniques: fundamentals and applications. In: Kulkarni P, Baron PA, Willeke K, eds. *Aerosol measurement: principles, techniques, and applications*. Hoboken, NJ: John Wiley & Sons.

Staton SJR, Castillo JA, Taylor TJ, Herckes P, Hayes MA [2013]. Identifying indoor environmental patterns from bioaerosol material using HPLC. *Anal Bioanal Chem* 405(1):351-357.

Stewart GL, Parkman PD, Hopps HE, Douglas RD, Hamilton JP, Meyer HM, Jr. [1967]. Rubella-virus hemagglutination-inhibition test. *N Engl J Med* 276(10):554-557.

Summerbell RC, Green BJ, Corr D, Scott JA [2011]. Molecular methods for bioaerosol characterization. In: Flannigan B, Samson RA, Miller JD, eds. *Microorganisms in home and indoor work environments: diversity, health impacts, investigation and control*, 2nd Edition. Boca Raton, FL: CRC Press, Taylor and Francis Group.

Takahashi Y, Nagoya T, Watanabe M, Inouye S, Sakaguchi M, Katagiri SA [1993]. A new method of counting airborne Japanese cedar (*Cryptomeria japonica*) pollen allergens by immunoblotting. *Allergy* 48:94-98.

Takahashi Y, Nilsson S [1995]. Aeroallergen immunoblotting with human IgE antibody. *Grana* 34:357-360.

Tang JW [2009]. The effect of environmental parameters on the survival of airborne infectious agents. *J R Soc Interface* 6(Suppl 6):S737-S746.



Tang W, Kuehn TH, Simcik MF [2015]. Effects of temperature, humidity and air flow on fungal growth rate on loaded ventilation filters. *J Occup Environ Hyg* 12(8):525-537.

Taubel M, Karvonen AM, Reponen T, Hyvarinen A, Vesper S, Pekkanen J [2016]. Application of the environmental relative moldiness index in Finland. *Appl Environ Microbiol* 82(2):578-584.

Thermo Fisher Scientific [2014]. *Molecular probes handbook—A guide to fluorescent probes and labeling technologies*, 11th Edition. Waltham, MA: ThermoFisher Scientific. <https://www.thermofisher.com/us/en/home/references/molecular-probes-the-handbook.html>.

Thompson KA, Pappachan JV, Bennett AM, Mittal H, Macken S, Dove BK, Nguyen-Van-Tam JS, Copley VR, O'Brien S, Hoffman P, Parks S, Bentley A, Isalska B, Thomson G, Consortium ES [2013]. Influenza aerosols in UK hospitals during the H1N1 (2009) pandemic—the risk of aerosol generation during medical procedures. *PLoS ONE* 8(2):e56278.

Thorne PS, DeKoster JA, Subramanian P [1996]. Environmental assessment of aerosols, bioaerosols, and airborne endotoxins in a machining plant. *Am Ind Hyg Assoc J* 57(12):1163-1167.

Thorne PS, Metwali N, Avol E, McConnell RS [2005]. Surface sampling for endotoxin assessment using electrostatic wiping cloths. *Ann Occup Hyg* 49(5):401-406.

Toivola M, Alm S, Reponen T, Kolari S, Nevalainen A [2002]. Personal exposures and microenvironmental concentrations of particles and bioaerosols. *J Environ Monit* 4(1):166-174.

Toprak E, Schnaiter M [2013]. Fluorescent biological aerosol particles measured with the Waveband Integrated Bioaerosol Sensor WIBS-4: laboratory tests combined with a one year field study. *Atmos Chem Phys* 13(1):225-243.

Tortora GJ, Funke BR, Case CL [2013]. *Microbiology - an introduction*. Glenview, IL: Pearson Education.

Tovey E, Taylor D, Graham A, O'Meara T, Lovborg U, Jones A, Sporik R [2000]. New immunodiagnostic system. *Aerobiologia* 16(1):113-118.



Tovey ER, Green BJ [2004]. Measuring environmental fungal exposure. *Med Mycol* 43(suppl 1):S67-S70.

Tovey ER, Liu-Brennan D, Garden FL, Oliver BG, Perzanowski MS, Marks GB [2016]. Time-based measurement of personal mite allergen bioaerosol exposure over 24 hour periods. *PLoS ONE* 11(5):e0153414.

Trouwborst T, Kuyper S [1974]. Inactivation of bacteriophage T3 in aerosols: effect of prehumidification on survival after spraying from solutions of salt, peptone, and saliva. *Appl Microbiol* 27(5):834-837.

Trunov M, Trakumas S, Willeke K, Grinshpun SA, Reponen T [2001]. Collection of bioaerosol particles by impaction: effect of fungal spore agglomeration and bounce. *Aerosol Sci Technol* 35(1):617-624.

Tsai CJ, Pui DYH [1990]. Numerical study of particle deposition in bends of a circular cross-section laminar-flow regime. *Aerosol Sci Technol* 12(4):813-831.

Tsai FC, Macher JM [2005]. Concentrations of airborne culturable bacteria in 100 large US office buildings from the BASE study. *Indoor Air* 15(Suppl 9):71-81.

Tseng C-C, Li C-S [2005]. Collection efficiencies of aerosol samplers for virus-containing aerosols. *J Aerosol Sci* 36(5-6):593-607.

Tseng CC, Chang LY, Li CS [2010]. Detection of airborne viruses in a pediatrics department measured using real-time qPCR coupled to an air-sampling filter method. *J Environ Health* 73(4):22-28.

Turgeon N, Toulouse MJ, Martel B, Moineau S, Duchaine C [2014]. Comparison of five bacteriophages as models for viral aerosol studies. *Appl Environ Microbiol* 80(14):4242-4250.

Unser S, Bruzas I, He J, Sagle L [2015]. Localized surface plasmon resonance biosensing: current challenges and approaches. *Sensors (Basel)* 15(7):15684-15716.

Usachev EV, Usacheva OV, Agranovski IE [2014]. Surface plasmon resonance-based bacterial aerosol detection. *J Appl Microbiol* 117(6):1655-1662.

USP [1997]. Microbiological evaluation of clean rooms and other controlled environments. *Pharmacoepial Forum* 23(6):5269-5295.



Verreault D, Gendron L, Rousseau GM, Veillette M, Masse D, Lindsley WG, Moineau S, Duchaine C [2011]. Detection of airborne lactococcal bacteriophages in cheese manufacturing plants. *Appl Environ Microbiol* 77(2):491-497.

Verreault D, Moineau S, Duchaine C [2008]. Methods for sampling of airborne viruses. *Microbiol Mol Biol Rev* 72(3):413-444.

Vesper S, Barnes C, Ciaccio CE, Johanns A, Kennedy K, Murphy JS, Nunez-Alvarez A, Sandel MT, Cox D, Dewalt G, Ashley PJ [2013]. Higher Environmental Relative Moldiness Index (ERMI) values measured in homes of asthmatic children in Boston, Kansas City, and San Diego. *J Asthma* 50(2):155-161.

Vesper S, McKinstry C, Haugland R, Wymer L, Bradham K, Ashley P, Cox D, Dewalt G, Friedman W [2007]. Development of an Environmental Relative Moldiness Index for US homes. *J Occup Environ Med* 49(8):829-833.

Vincent JH [2005]. Health-related aerosol measurement: a review of existing sampling criteria and proposals for new ones. *J Environ Monit* 7(11):1037-1053.

Vincent JH [2007]. *Aerosol sampling: science, standards, instrumentation and applications*. Hoboken, NJ: John Wiley & Sons.

Wagner J, Macher JM [2003]. Comparison of a passive aerosol sampler to size-selective pump samplers in indoor environments. *Am Ind Hyg Assoc J* 64(5):630-639.

Walls HJ, Ensor DS, Harvey LA, Kim JH, Chartier RT, Hering SV, Spielman SR, Lewis GS [2016]. Generation and sampling of nanoscale infectious viral aerosols. *Aerosol Sci Technol* 50(8):802-811.

Walter MV, Marthi B, Fieland VP, Ganio LM [1990]. Effect of aerosolization on subsequent bacterial survival. *Appl Environ Microbiol* 56(11):3468-3472.

Wang H, Reponen T, Lee SA, White E, Grinshpun SA [2007]. Size distribution of airborne mist and endotoxin-containing particles in metalworking fluid environments. *J Occup Environ Hyg* 4(3):157-165.

Wang Z, Reponen T, Grinshpun SA, Gorny RL, Willeke K [2001]. Effect of sampling time and air humidity on the bioefficiency of filter samplers for bioaerosol collection. *J Aerosol Sci* 32(5):661-674.



Warren JC, Akers TG, Dubovi EJ [1969]. Effect of prehumidification on sampling of selected airborne viruses. *Appl Microbiol* 18(5):893-896.

Weber TP, Stilianakis NI [2008]. Inactivation of influenza A viruses in the environment and modes of transmission: a critical review. *J Infect* 57(5):361-373.

West JS, Atkins SD, Emberlin J, Fitt BD [2008]. PCR to predict risk of airborne disease. *Trends Microbiol* 16(8):380-387.

Whitehead T, Leith D [2008]. Passive aerosol sampler for particle concentrations and size distributions. *J Environ Monit* 10(3):331-335.

WHO [2009]. WHO guidelines for indoor air quality: dampness and mould. Geneva: World Health Organization.

Wilken JA, Marquez P, Terashita D, McNary J, Windham G, Materna B [2014]. Coccidioidomycosis among cast and crew members at an outdoor television filming event--California, 2012. *MMWR Morb Mortal Wkly Rep* 63(15):321-324.

Wilken JA, Sondermeyer G, Shusterman D, McNary J, Vugia DJ, McDowell A, Borenstein P, Gilliss D, Ancock B, Prudhomme J, Gold D, Windham GC, Lee L, Materna BL [2015]. Coccidioidomycosis among workers constructing solar power farms, California, USA, 2011-2014. *Emerg Infect Dis* 21(11):1997-2005.

Willeke K, Lin X, Grinshpun SA [1998]. Improved aerosol collection by combined impaction and centrifugal motion. *Aerosol Sci Technol* 28(5):439-456.

Willeke K, Macher JM [1999]. Air sampling. In: Macher JM, ed. *Bioaerosols: assessment and control*. Cincinnati, OH: American Conference of Governmental Industrial Hygienists.

Wurtz H, Sigsgaard T, Valbjorn O, Doekes G, Meyer HW [2005]. The dustfall collector--a simple passive tool for long-term collection of airborne dust: a project under the Danish Mould in Buildings program (DAMIB). *Indoor Air* 15(Suppl 9):33-40.

Yang W, Elankumaran S, Marr LC [2011]. Concentrations and size distributions of airborne influenza A viruses measured indoors at a health centre, a day-care centre and on aeroplanes. *J R Soc Interface* 8(61):1176-1184.



Yooseph S, Andrews-Pfannkoch C, Tenney A, McQuaid J, Williamson S, Thiagarajan M, Bami D, Zeigler-Allen L, Hoffman J, Goll JB, Fadrosch D, Glass J, Adams MD, Friedman R, Venter JC [2013]. A metagenomic framework for the study of airborne microbial communities. *PLoS ONE* 8(12):e81862.

Zhao Y, Aarnink AJ, Wang W, Fabri T, Groot Koerkamp PW, de Jong MC [2014]. Airborne virus sampling: efficiencies of samplers and their detection limits for infectious bursal disease virus (IBDV). *Ann Agric Environ Med* 21(3):464-471.

Zimmerman NJ, Reist PC, Turner AG [1987]. Comparison of two biological aerosol sampling methods. *Appl Environ Microbiol* 53(1):99-104.

Zuo ZL, Kuehn TH, Verma H, Kumar S, Goyal SM, Appert J, Raynor PC, Ge S, Pui DYH [2013]. Association of airborne virus infectivity and survivability with its carrier particle size. *Aerosol Sci Technol* 47(4):373-382.

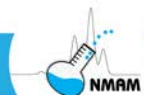

14 Appendix 1- List of manufacturers/distributors of common bioaerosol samplers and related products

This list is not inclusive, and the inclusion of a specific product or company does not constitute endorsement by the National Institute for Occupational Safety and Health (NIOSH). If your bioaerosol equipment manufacturing or supply company is not listed or the information is incorrect or out-of-date, please contact us and we will review your information for inclusion as the list is updated.

Manufacturers/Distributors of Common Bioaerosol Samplers and Related Products

A.P. Buck Inc.
7101 Presidents Drive, Suite 110
Orlando, FL 32809 USA
Phone: (800) 330-BUCK [2825]
Phone: (407) 851-8602
Fax: (407) 851-8910
<http://www.apbuck.com>

Ace Glass Incorporated
1430 North West Boulevard
P.O. Box 688
Vineland, NJ 08362 USA
Phone: (800) 223-4524
Phone: (856) 692-3333
Fax: (800) 543-6752
Fax: (856) 692-8919
<http://www.aceglass.com>

Aerosol Devices Inc.
2614 S. Timberline Road, #109-125
Fort Collins, CO 80525 USA
Phone: (970) 744-3244
<http://aerosoldevices.com>

Aquaria srl
Via della Levata, 14
Lacchiarella (Milan) 20084 Italy
Phone: +39 02-90091399
Fax: +39 02-9054861
<http://www.aquariasrl.com>

Barramundi Corporation
6449 South Tex Point
PO Drawer 4259
Homosassa, FL 34448 USA

Phone: (800) 382-1817
Phone: (352) 628-0200
Fax: (352) 628-0203
<http://barramundicorp.com>

BD Biosciences
2350 Qume Drive
San Jose, CA 95131
Phone: 877-232-8995
<http://www.bdbiosciences.com>

Beijing SENNON Technology
Development Company, Ltd.
North Building No. 2
Dongdajie xili, Fengtai District
Beijing 100071 P.R. China
Phone: +86 10-6381 8024
Fax: +86 10-6380 6170
<http://www.sennon.net/eng>

Bertin Corporation
9700 Great Seneca Highway
Suite # 662
Rockville, MD 20850 USA
Phone: (240) 428-1047
<http://www.coriolis-air sampler.com>

Bi-Air Corporation
1349 Montevideo Ave
Placentia, CA 92870 USA
Phone: (714) 985-9659
Fax: (714) 528-5429
<http://expertonmold.com>

bioMérieux, Inc.
595 Anglum Road
Hazelwood, MO 63042 USA
Phone: (800) 634-7656
Fax: (800) 657-3053
<http://www.biomerieux-usa.com>

Bioscience International
11333 Woodglen Drive
Rockville, MD 20852 USA
Phone: (301) 231-7400
Fax: (301) 231-7277
<http://www.biosci-intl.com>

Burkard Manufacturing Company
Ltd.
Woodcock Hill Industrial Estate
Rickmansworth, Hertfordshire WD3
1PJ England
Phone: +44 (0) 1923 773134
Fax: +44 (0) 1923 774790
<http://www.burkard.co.uk>

Climet Instruments Company
1320 W. Colton Avenue
Redlands, CA 92374 USA
Phone: (909) 793-2788
<http://www.climet.com>

Droplet Measurement Technologies
2545 Central Avenue
Boulder, CO 80301 USA
Phone: (303) 440-5576 Fax: (303) 440-1965
<http://www.dropletmeasurement.com>

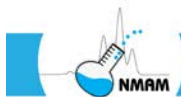
**Manufacturers/Distributors of Common Bioaerosol Samplers and Related Products - Continued**

Dycor Technologies, Ltd.
1851 94th Street
Edmonton, AB T6N 1E6 Canada
Phone: (800) 663-9267
Phone: (780) 486-0091
Fax: (780) 486-3535
<http://www.dycor.com>

EMD Millipore
290 Concord Road
Billerica, MA 01821 USA
Phone: (800) MILLIPORE [645-5476]
Fax: (781) 533-6000
<http://www.emdmillipore.com>

EMSL Analytical, Inc
200 Route 130 North
Cinnaminson, NJ 08077
Phone: (800) 220-3675
<http://www.emsl.com> Environics Oy

Environmental Monitoring Systems, Inc.
3864 Leeds Avenue
Charleston, SC 29405 USA
Phone: (800) 293-3003
Phone: (843) 724-5708
Fax: (866) 724-5702
Fax: (843) 724-5702
<http://www.emssales.net>

Evogen, Inc.
10513 W. 84th Terrace
Lenexa, KS 66214 USA
Phone: (888) 450-4321
Phone: (913) 948-5640
Fax: (913) 948-5664
<http://evogen.com>

F.W. Parrett Limited
7 Coppergate Close
Bromley, Kent BR1 3JG England
Phone: +44 020-8460-2116
Fax: +44 020-7504-3536
<http://www.parrett.uk.com>

FLIR Systems, Inc.
70 Castilian Drive
Goleta, CA 93117 USA
Phone: (888) 747-FLIR [3547]
<http://www.flir.com>

GE Healthcare Life Sciences
(Whatman)
800 Centennial Avenue
P.O. Box 1327
Piscataway, NJ 08855 USA
Phone: (800) 526-3593
Fax: (877) 295-8102
<http://www.gelifesciences.com>

Indoor Biotechnologies Inc
700 Harris Street
Charlottesville, VA 22903 USA
<https://inbio.com>

InnovaPrep
132 East Main Street
Drexel, MO 65742 USA
Phone: (816) 619-3375
<http://innovaprep.com>

InnovaTek, Inc.
3100 G. Washington Way
Suite 108
Richland, WA 99354 USA
Phone: (509) 375-1093
Fax: (509) 375-5183
<http://www.innovatek.com>

Inspirotec
2319 West Wabansia Avenue #1
Chicago, IL 60647
Phone: 847 302 1839
Fax: 847 234 2089
<http://www.inspirotec.com>

MSP Corporation
5910 Rice Creek Parkway
Suite 300
Shoreview, MN 55126 USA
Phone: (651) 287-8100
Fax: (651) 287-8140
<http://www.msppcorp.com>

Pall Corporation
25 Harbor Park Drive
Port Washington, NY 11050 USA
Phone: (800) 521-1520
Phone: (516) 484-3600
Fax: (516) 801-9754
<http://www.pall.com>

Particle Measuring Systems
5475 Airport Boulevard
Boulder, CO 80301 USA
Phone: (800) 238-1801
Phone: (303) 443-7100
Fax: (303) 449-6870
<http://pmeasuring.com>

Research International, Inc.
17161 Beaton Road SE
Monroe, WA 98272 USA
Phone: (800) 927-7831
Phone: (360) 805-4930
Fax: (360) 863-0439
<http://www.resrchintl.com>

RJ Lee Group, Inc.
350 Hochberg Road
Monroeville, PA 15146
Manufacturers/Distributors of
Common Bioaerosol Samplers and
Related Products
(724) 325-1776
Fax: (724) 733-1799
<http://www.rjlg.com>

Sammonkatu 12
P.O. Box 349
FI-50101 Mikkeli Finland
Phone: +358 201 430 430
Fax: +358 201430 440
<http://www.environics.fi/>

Sartorius Stedim Biotech GmbH
August-Spindler-Strasse 11
Goettingen 37079 Germany
Phone: (800) 368-7178
Phone: +49 551-308-0
Fax: +49 551-308-3289
<https://www.sartorius.com>

SKC, Inc.
863 Valley View Road
Eighty Four, PA 15330 USA
Phone: (800) 752-8472
Phone: (724) 941-9701
Fax: (724) 941-1369
<http://www.skcinc.com>

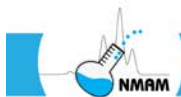

Manufacturers/Distributors of Common Bioaerosol Samplers and Related Products - Continued

Tecora

211-215 Rue la Fontaine
94134 Fontenay sous Bois Cedex, France
Phone: Tel: +33 1 48 75 82 82
Fax: +33 1 48 75 82 96
<http://www.tecora.com/en/>

Thermo Scientific

27 Forge Parkway
Franklin, MA 02038 USA
Phone: (866) 282-0430
Phone: (508) 520-0430
Fax: (508) 520-1460
<http://www.thermoscientific.com>

TSI Incorporated

500 Cardigan Road
Shoreview, MN 55126 USA
Phone: (800) 874-2811
Phone: (651) 483-0900
Fax: (651) 490-3824
<http://www.tsi.com>

Veltek Associates, Inc.

15 Lee Boulevard
Malvern, PA 19355 USA
Phone: (888) 4-STERILE [478-3745]
Phone: (610) 644-8335
<http://sterile.com>

Zefon International, Inc.

5350 SW 1st Lane
Ocala, FL 34474 USA
Phone: (800) 282-0073
Phone: (352) 854-8080
Fax: (352) 854-7480
<http://www.zefon.com>



15 Appendix 2 – Commonly used bioaerosol samplers

This list is not inclusive, and the inclusion of a specific product or company does not constitute endorsement by the National Institute for Occupational Safety and Health (NIOSH). If a bioaerosol sampler is not listed or the information is incorrect or out-of-date, please contact us and we will review your information for inclusion as the list is updated.

| <i>Manufacturer/ Distributor</i> | <i>Sampler Name</i> | <i>Collection Media</i> | <i>Flowrate (L/min)</i> | <i>d₅₀ (μm)</i> | <i>Application[‡]</i> |
|--------------------------------------|--|-----------------------------|-----------------------------|--------------------------------|--------------------------------|
| Bi-Air | Bi-Air Filter Cassette | Filter | 1 – 5 | Varies | C,M,O |
| Burkard | High Throughput 'Jet' Spore and Particle Sampler | Filter | 850 | Varies | C,M,O |
| Dycor | CSU-1 Low Volume Air Sampler | Filter | 10 | Varies | C,M,O |
| EMD Millipore | Various filter and membrane media | Filter | Varies | Varies | C,M,O |
| GE (Whatman) | Various filter and membrane media | Filter | Varies | Varies | C,M,O |
| InnovaPrep | ACD-200 Bobcat Air Sampler | Filter | 100 or 200 | | C,M,O |
| Pall Corp. | Various filter and membrane media | Filter | Varies | Varies | C,M,O |
| Research International | SASS® 3100 Dry Air Sampler | Filter | 50 – 310 | 0.3 – 0.5 | C,M,O |
| Sartorius | AirPort MD8 Air Sampler | Filter | 30, 40, or 50 | - | C |
| SKC | Button Aerosol Sampler | Filter | 4 | - | M,O |
| Zefon | Various filter and membrane media | Various | Varies | Varies | C,M,O |

d₅₀ – aerodynamic diameter at which the collection efficiency is 50% and is defined as the cut off diameter

Application[‡] -

C = culture-based analysis for viability

M = microscopic examination of collected bioaerosol

O = other laboratory analyses, such as immunoassays, bioassays, chemical assays, or molecular detection techniques



| Table II A. Common Commercially-Available Single-stage Impactor Samplers for Bioaerosol Collection | | | | | |
|---|--|-----------------------------|-----------------------------|--------------------------------|--------------------------------|
| <i>Manufacturer/ Distributor</i> | <i>Sampler Name</i> | <i>Collection Media</i> | <i>Flowrate (L/min)</i> | <i>d₅₀ (μm)</i> | <i>Application[‡]</i> |
| A.P. Buck | BioAire™ B6 Single Stage Microbial Sampler | Agar | 28.3 | - | C |
| | Bio-Culture™ Microbial Air Sampler | Agar | 30 – 120 | - | C |
| | BioSlide™ Microbial Air Sampler | Slide | 10 – 20 | - | M |
| Aquaria | MICROFLOW 60 Microbiological Air Sampler | Agar | 30 – 120 | - | C |
| | MICROFLOW 60-90/C Microbiological Air Sampler | Agar | 30 – 120 | - | C |
| | MICROFLOW 90/C Microbiological Air Sampler | Agar | 30 – 120 | - | C |
| Barramundi | Mattson-Garvin Model 220 Air Sampler (240V is Model 270) | Agar | 28.3 | - | C |
| Beijing SENNON | Handy Microbial Air Sampler® | Agar/Filter | - | - | C,M,O |
| | JWL-IIA Mini® Microbial Air Sampler | Agar | 20 | - | C |
| | JWL-IIB202 Universal® Microbial Air Sampler | Agar | 20 | - | C |
| | JWL-IIC Professional® Microbial Air Sampler | Agar | 20 | - | C |
| bioMérieux | airIDEAL® 3P™ Traceability Air Sampler | Agar | 100 | - | C |
| | Samp'air™ Microbial Air Sampler | Agar | 100 | - | C |
| Bioscience International | SAS Duo 360 High Volume Microbial Air Sampler | Agar | 360 | - | C |
| | SAS Isolator Microbial Air Sampler | Agar | 180 | - | C |
| | SAS Super 100 Microbial Air Sampler | Agar | 100 | - | C |
| | SAS Super 180 Microbial Air Sampler | Agar | 180 | - | C |
| Burkard | 24-Hour Recording Volumetric Spore Trap | Slide | 10 | - | M |
| | Continuous Recording Air Sampler | Slide | 10 | - | M |
| | Personal Volumetric Air Sampler | Slide | 10 | - | M |
| | Portable Air Sampler for Agar Plates | Agar | 10 or 20 | - | C |
| | Recording Air Sampler | Slide | 10 | - | M |
| | Seven-Day Recording Volumetric Spore Trap | Slide | 10 | - | M |
| Climet | CI-90 & CI-90+ Airborne Microbial Sampler | Agar | 100 | - | C |
| | CI-95 & CI-95+ Airborne Microbial Sampler | Agar | 100 | - | C |
| | CI-99 Microbial Air Sampler | Agar | 100 | - | C |
| Dycor | Dycor Slit Sampler | Agar | 15 – 50 | - | C |
| EMD Millipore | MAS-100 Iso MH® Air Sampler | Agar | 100 | - | C |
| | MAS-100 Iso NT® Air Sampler | Agar | 100 | - | C |
| | MAS-100 NT® and MAS-100 NT Ex® Air Sampler | Agar | 100 | - | C |
| | MAS-100 VF® Active Air Sampler | Agar | 100 | - | C |
| | RCS® Isolator Microbial Air Sampler | Agar | 100 | - | C |
| | RCS® Plus Ex Explosion-Proof Microbial Air Sampler | Agar | 100 | - | C |



| Table II A. Common Commercially-Available Single-stage Impactor Samplers for Bioaerosol Collection - Continued | | | | | |
|---|---|-----------------------------|-----------------------------|--------------------------------|--------------------------------|
| <i>Manufacturer/ Distributor</i> | <i>Sampler Name</i> | <i>Collection Media</i> | <i>Flowrate (L/min)</i> | <i>d₅₀ (μm)</i> | <i>Application[†]</i> |
| EMD Millipore | RCS® High Flow Touch Portable Air Sampler | Agar | 100 | - | C |
| Environmental Monitoring Systems | Allergenco MK-III Slit-Impaction Sampler | Slide | 15 | - | M |
| | Allergenco-D Disposable IAQ Air Monitoring Cassettes | Slide | 15 | - | M |
| | Allergenco-D Posi-Track Full Slide, IAQ Impactor Cassette | Slide | 15 | 1.7 | M |
| | BioSIS Slit Impaction Air Sampler | Slide | 5 – 50 | - | M |
| | cyclex-d Cassettes | Slide | 20 | < 1.0 | M |
| | E6 Single-Stage Bioaerosol Impaction Sampler | Agar | 28.3 | - | C |
| | Micro5 MicroCell Cassettes | Slide | 5 | < 1.0 | M |
| | Micro5 Posi-Track Full Slide, IAQ Impactor Cassette | Slide | 5 | <1.0 | M |
| F.W. Parrett | MicroBio MB1 Air Sampler | Agar | 100 | - | C |
| | MicroBio MB2 Air Sampler | Agar | 100 | - | C |
| Particle Measuring Systems | Air Trace® Environmental Slit-to-Agar Sampler | Agar | 28.3 | - | C |
| | BioCapt™ Impactor Active Microbial Air Sampling Atrium | Agar | 25 | - | C |
| | MiniCapt™ Portable Microbial Air Sampler | Agar | 50 or 100 | - | C |
| Sartorius | AirPort MD8 Air Sampler | Agar | 125 | - | C |
| SKC | BioStage® Standard Single-Stage Viable Cascade Impactor | Agar | 28.3 | - | C |
| | BioStage® 200 Single-Stage Viable Cascade Impactor | Agar | 14.15 | - | C |
| | VersaTrap® Spore Trap Cassette | Slide | 15 | - | M |
| Thermo Scientific | IUL Basic Air Air Sampler | Agar | 60 – 100 | - | C |
| | IUL Spin Air Air Sampler | Agar | 60 – 100 | - | C |
| | IUL Spin Air Basic Air Sampler | Agar | 60 – 100 | - | C |
| | N6 Single-Stage Viable Andersen Impactor | Agar | 28.3 | 0.65 | C |
| | Oxoid Air Sampler | Agar | 100 | - | C |
| Veltek | SMA MicroPortable® Air Sampler | Agar | 1 or 5 | - | C |
| Zefon International | A-6 Bioaerosol Impactor | Agar | 28.3 | 0.65 | C |
| | Air-O-Cell® Sampling Cassette | Slide | 15 | 2.6 | M |
| | Via-Cell® Bioaerosol Sampling Cassette | Slide | 15 | 1.56 | C,M,O |

d₅₀ – aerodynamic diameter at which the collection efficiency is 50% and is defined as the cut off diameter

Application[†] -

C = culture-based analysis for viability

M = microscopic examination of collected bioaerosol

O = other laboratory analyses, such as immunoassays, bioassays, chemical assays, or molecular detection techniques



Table II B. Common Commercially-Available Multi-stage Impactor Samplers for Bioaerosol Collection

| <i>Manufacturer/ Distributor</i> | <i>Sampler Name</i> | <i>Collection Media</i> | <i>Flowrate (L/min)</i> | <i># of Stages</i> | <i>d₅₀ (μm)</i> | <i>Application*</i> |
|--------------------------------------|--|-----------------------------|-----------------------------|------------------------|---|---------------------|
| MSP Corporation | Model 100-NR (non-rotating)/100-R (rotating) MOUDI™ Impactor | Filter | 30 | 8 | 0.18 0.32 0.56 1.0 1.8 3.2 5.6 10 | M,O |
| | Model 110-NR (non-rotating)/100-R (rotating) MOUDI™ Impactor | Filter | 30 | 10 | 0.056 0.10 0.18 0.32 0.56 1.0 1.8 3.2 5.6 10 | M,O |
| | Model 100-S4 MOUDI™ Impactor | Filter | 30 | 3 | 1.0 2.5 10 | M,O |
| | Model 115 Nano-MOUDI™ Impactor | Filter | 10 | 3 | 0.010 0.018 0.032 | M,O |
| | Model 116 Nano-MOUDI™ Impactor | Filter | 30 | 3 | 0.010 0.018 0.032 | M,O |



| Table II B. Common Commercially-Available Multi-stage Impactor Samplers for Bioaerosol Collection - Continued | | | | | | |
|--|---|-----------------------------|-----------------------------|------------------------|--|---------------------|
| <i>Manufacturer/ Distributor</i> | <i>Sampler Name</i> | <i>Collection Media</i> | <i>Flowrate (L/min)</i> | <i># of Stages</i> | <i>d₅₀ (μm)</i> | <i>Application*</i> |
| MSP Corporation continued | Model 120 R (rotating) Moudi-II™ Impactor | Filter | 30 | 10 | 0.056 0.10 0.18 0.32 0.56 1.0 1.8 3.2 5.6 10 | M,O |
| | Model 122-NR/122-R Moudi-II™ and NanoMoudi-II™ Impactor | Filter | 30 | 13 | 0.010 0.018 0.032 0.056 0.10 0.18 0.32 0.56 1.0 1.8 3.2 5.6 10 | M,O |



| Table II B. Common Commercially-Available Multi-stage Impactor Samplers for Bioaerosol Collection - Continued | | | | | | |
|--|---|-----------------------------|-----------------------------|------------------------|--|---------------------|
| <i>Manufacturer/ Distributor</i> | <i>Sampler Name</i> | <i>Collection Media</i> | <i>Flowrate (L/min)</i> | <i># of Stages</i> | <i>d₅₀ (μm)</i> | <i>Application*</i> |
| MSP Corporation continued | Model 125-NR/125-R Moudi-II™ and NanoMoudi-II™ Impactor | Filter | 10 | 13 | 0.010 0.018 0.032 0.056 0.10 0.18 0.32 0.56 1.0 1.8 3.2 5.6 10 | M,O |
| | Model 135-6 MiniMOUDI™ (Marple Personal II) Impactor | Filter | 2 | 6 | 0.56 1.0 1.8 3.2 5.6 10 | M,O |
| | Model 135-8 MiniMOUDI™ (Marple Personal II) Impactor | Filter | 2 | 8 | 0.18 0.32 0.56 1.0 1.8 3.2 5.6 10 | M,O |



| Table II B. Common Commercially-Available Multi-stage Impactor Samplers for Bioaerosol Collection - Continued | | | | | | |
|--|---|-----------------------------|-----------------------------|------------------------|--|---------------------|
| <i>Manufacturer/ Distributor</i> | <i>Sampler Name</i> | <i>Collection Media</i> | <i>Flowrate (L/min)</i> | <i># of Stages</i> | <i>d₅₀ (μm)</i> | <i>Application*</i> |
| MSP Corporation continued | Model 135-10 MiniMOUDI™ Impactor | Filter | 2 | 10 | 0.056 0.10 0.18 0.32 0.56 1.0 1.8 3.2 5.6 10 | M,O |
| | Model 135-13 MiniMOUDI™ Impactor | Filter | 2 | 13 | 0.010 0.018 0.032 0.056 0.10 0.18 0.32 0.56 1.0 1.8 3.2 5.6 10 | M,O |
| Thermo Scientific | Eight Stage Non-Viable Cascade Impactor | Filter | 28.3 | 8 | 0.43 0.65 1.1 2.1 3.3 4.7 5.8 9.0 | M,O |



| <i>Manufacturer/ Distributor</i> | <i>Sampler Name</i> | <i>Collection Media</i> | <i>Flowrate (L/min)</i> | <i># of Stages</i> | <i>d₅₀ (µm)</i> | <i>Application*</i> |
|--------------------------------------|--|-----------------------------|-----------------------------|------------------------|---|---------------------|
| Thermo Scientific continued | Marple 294 Personal Cascade Impactor | Filter | 2 | 4 | 3.5 9.8 14.8 21.3 | M,O |
| | Marple 296 Personal Cascade Impactor | Filter | 2 | 6 | 0.52 0.93 1.55 3.5 6.0 9.8 | M,O |
| | Marple 298 Personal Cascade Impactor | Filter | 2 | 8 | 0.52 0.93 1.55 3.5 6.0 9.8 14.8 21.3 | M,O |
| | Six Stage Viable Andersen Cascade Impactor | Agar | 28.3 | 6 | 0.65 1.1 2.1 3.3 4.7 7.0 | C |
| | Two-Stage Viable Andersen Cascade Impactor | Agar | 28.3 | 2 | 0.8 8 | C |

*d*₅₀ – aerodynamic diameter at which the collection efficiency is 50% and is defined as the cut off diameter

*Application** -

C = culture-based analysis for viability

M = microscopic examination of collected bioaerosol

O = other laboratory analyses, such as immunoassays, bioassays, chemical assays, or molecular detection techniques



Table III. Common Commercially-Available Cyclones and Impinger Samplers for Bioaerosol Collection

| Cyclones | | | | | | |
|--------------------------------------|--|-----------------------------|-----------------------------|------------------------|--------------------------------|--------------------------------|
| <i>Manufacturer/ Distributor</i> | <i>Sampler Name</i> | <i>Collection Media</i> | <i>Flowrate (L/min)</i> | <i># of Stages</i> | <i>d₅₀ (μm)</i> | <i>Application[‡]</i> |
| Burkard | Cyclone Sampler for Airborne Particles | Dry Vial | 20 | 1 | - | C,M,O |
| | Cyclone Sampler for Field Operation | Dry Vial | 16.5 | 1 | - | C,M,O |
| Evogen | Sceptor DryClone™ | Dry Vial | 400 | 1 | - | C,M,O |
| FLIR Systems | C100 Modular Tactical Collector | Dry Vial | 150 | 1 | - | C,M,O |
| Impingers | | | | | | |
| Ace Glass | AGI-30 Impinger | Liquid | 12.5 | 1 | - | C,M,O |
| | Greenburg-Smith Impinger | Liquid | 28.3 | 1 | - | C,M,O |
| | Midget Impinger | Liquid | | 1 | - | C,M,O |
| Burkard | Multistage Liquid Impinger | Liquid | 20 | 3 | 4 10 > 10 | C,M,O |
| Dycor | XXM/102 High Volume Bioaerosol Sampling System | Serum Tube | 530 | 1 | - | C,O |
| | XXM/2L-MIL Bioaerosol Sampler – Military | Liquid | 530 | 1 | - | C,M,O |
| | XXM-CV Microbial Air Sampler – Civilian | Liquid | 530 | 1 | - | C,M,O |

d₅₀ – aerodynamic diameter at which the collection efficiency is 50% and is defined as the cut off diameter

Application[‡] -

C = culture-based analysis for viability

M = microscopic examination of collected bioaerosol

O = other laboratory analyses, such as immunoassays, bioassays, chemical assays, or molecular detection techniques



Table IV. Common Commercially-Available Wetted-Surface and Condensation-Based Samplers for Bioaerosol Collection

| Wetted-Surface Bioaerosol Samplers | | | | | | |
|---|---|-----------------------------|-----------------------------|------------------------|--------------------------------|--------------------------------|
| <i>Manufacturer/ Distributor</i> | <i>Sampler Name</i> | <i>Collection Media</i> | <i>Flowrate (L/min)</i> | <i># of Stages</i> | <i>d₅₀ (μm)</i> | <i>Application[‡]</i> |
| Bertin | Coriolis® μ Microbial Air Sampler | Liquid | 100 – 300 | 1 | < 0.5 | C,M,O |
| | Coriolis® RECON Portable Air Sampler | Liquid | 600 | 1 | ≈ 0.5 | C,M,O |
| Bioscience International | SAS Cyclone Air Sampler | Liquid | 1200 | 1 | - | C,M,O |
| Evogen | Sceptor SpinCon™ Advanced Air Sampler | Liquid | 450 | 1 | - | C,M,O |
| FLIR Systems | Fido® B1 (BioCapture® 650) Portable Air Sampler | Liquid Cartridge | 200 | 1 | - | C,M,O |
| InnovaPrep | SpinCon® II Advanced Air Sampler | Liquid | 450 | 1 | - | C,M,O |
| InnovaTek | BioGuardian® Air Sampler | Liquid | 100, 350, or 1000 | 1 | - | C,M,O |
| Research International | BioHawk® 8-Channel Collector/Bioidentifier | Liquid | 325 | 1 | - | O |
| | SASS® 2300 Wetted-Wall Air Sampler | Liquid | 325 | 1 | - | C,M,O |
| | SASS® 2400 Low-Volume Wetted-Wall Air Sampler | Liquid | 40 | 1 | - | C,M,O |
| SKC | BioSampler® | Liquid | 12.5 | 1 | - | C,M,O |
| Tecora | CIP10-M personal bioaerosol sampler | Liquid | 10 | 1 | 2.1 | C,M,O |
| Condensation-Based Bioaerosol Samplers | | | | | | |
| Aerosol Devices | LSS100 Series Liquid Spot Sampler | Liquid | 1.0 – 1.5 | 1 | n/a | C,M,O |

d₅₀ – aerodynamic diameter at which the collection efficiency is 50% and is defined as the cut off diameter

Application[‡] -

C = culture-based analysis for viability

M = microscopic examination of collected bioaerosol

O = other laboratory analyses, such as immunoassays, bioassays, chemical assays, or molecular detection techniques



| Table V. Common Commercially-Available Electrostatic, Passive Aerosol and Settled Dust Collection Samplers for Bioaerosol Collection | | | | | | |
|--|------------------------------------|----------------------------------|-----------------------------|------------------------|--------------------------------|--------------------------------|
| Electrostatic Samplers | | | | | | |
| <i>Manufacturer/ Distributor</i> | <i>Sampler Name</i> | <i>Collection Media</i> | <i>Flowrate (L/min)</i> | <i># of Stages</i> | <i>d₅₀ (μm)</i> | <i>Application[‡]</i> |
| Inspirotec | Inspirotec sampler | Cartridge | 130 | 1 | n/a | O |
| Passive electrostatic dust collectors are listed under Passive Aerosol Samplers. Electrostatic cloths used for wipe sampling are listed under Settled Dust Collection Devices. | | | | | | |
| Passive Aerosol Samplers | | | | | | |
| BD Biosciences | Ready-to-use settle plates | Agar | n/a | n/a | n/a | C |
| EMD Millipore | Ready-to-use settle plates | Agar | n/a | n/a | n/a | C |
| Thermo-Scientific | Ready-to-use settle plates | Agar | n/a | n/a | n/a | C |
| Department of Occupational and Environmental Health, University of Iowa | Electrostatic Dust Collector (EDC) | Electrostatically-charged cloths | n/a | n/a | n/a | O |
| RJ Lee Group | UNC Passive Aerosol Sampler | Various substrates | n/a | n/a | n/a | M, O |
| Settled Dust Collection Devices | | | | | | |
| Indoor Biotechnologies | DUSTREAM® Collector (DU-ST-1) | 40 μm nylon mesh filter | n/a | n/a | n/a | O |

d₅₀ – aerodynamic diameter at which the collection efficiency is 50% and is defined as the cut off diameter

Application[‡] -

C = culture-based analysis for viability

M = microscopic examination of collected bioaerosol

O = other laboratory analyses, such as immunoassays, bioassays, chemical assays, or molecular detection techniques



Table VI. Common Commercially-Available Real-Time Bioaerosol Monitors for Bioaerosol Collection

| <i>Manufacturer/ Distributor</i> | <i>Sampler Name</i> | <i>Detection Method</i> | <i>Flowrate (L/min)</i> | <i>Application[‡]</i> |
|--------------------------------------|--|-------------------------|-----------------------------|--------------------------------|
| Bioscience International | SAS-PCR Pathogenic Microorganisms Air Sampler | PCR | - | R |
| Droplet Measurement Technologies | Wideband Integrated Bioaerosol Sensor (WIBS) | Fluorescence | 0.3 | R |
| Dycor | C-FLAPS Biological Detection System | Fluorescence | 350 | R |
| EnviroNics | ENVI BioScout™ | Fluorescence | 2 | R |
| FLIR Systems | Fido® B2 Instantaneous Biological Aerosol Detector | Fluorescence | 3.8 | R |
| Particle Measuring Systems | BioLaz™ Real-Time Microbial Monitor | Fluorescence | 3.6 | R |
| Research International | BioHawk® 8-Channel Collector/BioIdentifier | Fluorometric Bioassay | 325 | R |
| | TacBio™ Biological Aerosol Detector | Fluorescence | 1 | R |
| TSI | BIOTRAK® Real-Time Viable Particle Counter 9510-BD | Fluorescence | 28.3 | R |
| | Fluorescence Aerosol Particle Sensor (FLAPS) 3317 (FLAPS III)™ | Fluorescence | 1 | R |

Application[‡] -

R= Real-time or near-real time bioaerosol detection

PCR= Polymerase chain reaction



NIOSH Manual of Analytical Methods (NMAM), 5th Edition

Filter Pore Size and Aerosol Sample Collection

by William G. Lindsley, PhD, NIOSH

| | | |
|---|---|-------|
| 1 | Introduction | FP-2 |
| 2 | Physical structures of filters | FP-2 |
| 3 | Determination of equivalent pore diameter | FP-3 |
| 4 | How an aerosol filter collect particles | FP-6 |
| 5 | Aerosol filter efficiency and pore size | FP-8 |
| 6 | Significance of pore size | FP-10 |
| 7 | Filter selection | FP-11 |
| 8 | Conclusion | FP-12 |
| 9 | References | FP-13 |



Centers for Disease Control
and Prevention
National Institute for Occupational
Safety and Health



1 Introduction

Aerosol sampling filters are commonly used in industrial hygiene and environmental monitoring to collect airborne particles for analysis. The filter characteristics provided by the manufacturer frequently include the term “pore size” or “equivalent pore diameter,” and pore size is also specified in many particle-sampling methods written by government agencies and standards organizations. Unfortunately, the pore size of a filter is often misunderstood, which can lead to the misinterpretation of test results and the selection of filters with much higher flow resistances than are needed for a particular application. The purpose of this article is to discuss how aerosol filters actually work and what the equivalent pore diameter really means, and then to explain how this information should be used when selecting filters and interpreting data. Much of the information and terminology presented here were drawn from Hinds [1999], Brock [1983], Lippmann [2001] and Raynor et al. [2011]. All of these sources provide a more in-depth discussion of filter theory and use and are highly recommended if more information is desired.

2 Physical structures of filters

To understand what the term “pore size” does and does not indicate for filters, we begin by looking at the physical structures of some different types of filters. Most filters used in aerosol sampling fall into one of three categories. Fibrous filters like the glass fiber filter shown in Figure 1A consist of a deep mesh of fibers with random orientations. Porous membrane filters, such as those made from mixed cellulose esters (MCE) or polytetrafluoroethylene (PTFE), have a complex structure with tortuous routes through the filter material as shown in Figures 1B and 1C. A capillary pore filter consists of a thin, smooth polycarbonate (PC) or polyethylene terephthalate (PET) film with circular pores, as shown in Figure 1D. These are also called straight-through pore filters or track-etch membrane filters (because of the manufacturing method), or Nucleopore filters after the original manufacturer.

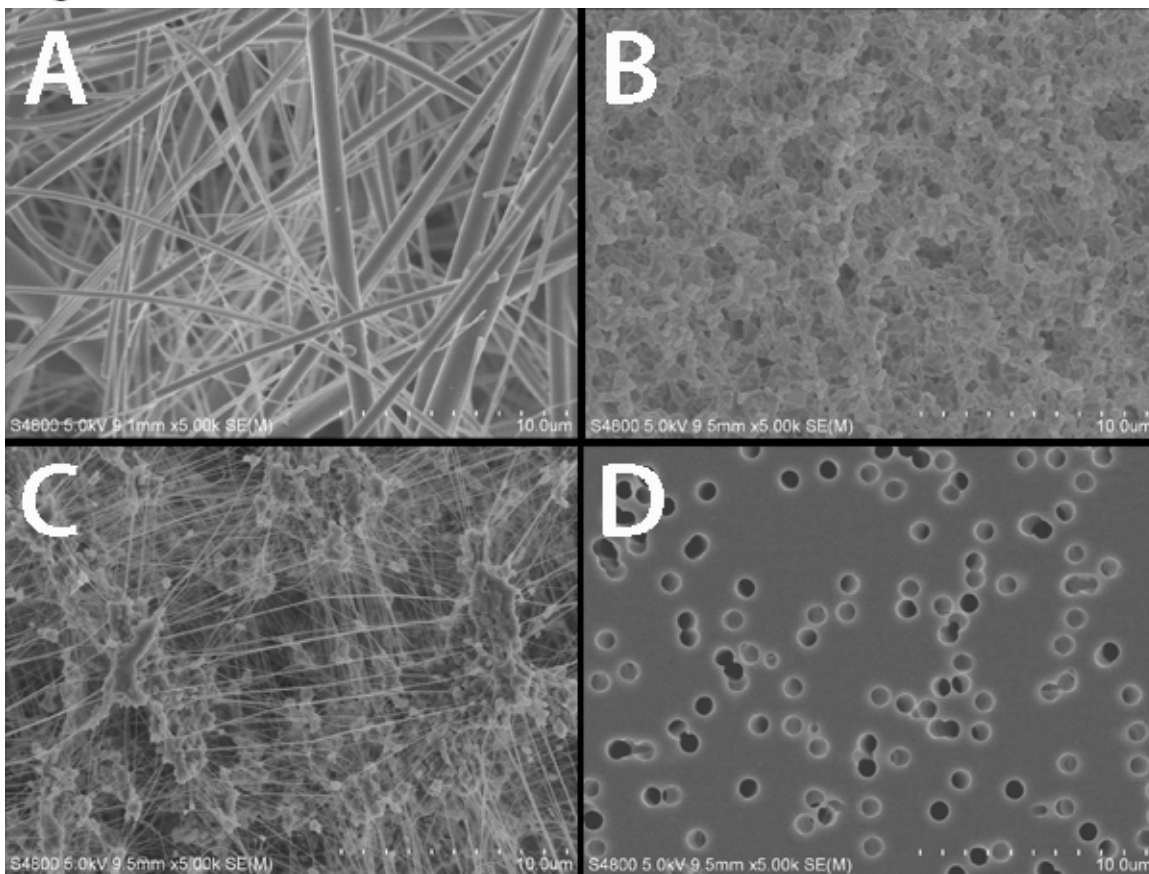

Figure 1: Scanning Electron Micrographs (SEM) of four filter types. The vertical tick marks above “10.0 µm” in the lower right-hand corner of each SEM are 1 µm apart; the entire scale is 10 µm in length.

A: Glass fiber filter with a 1-µm equivalent pore diameter.

B: Mixed-cellulose esters (MCE) filter with 0.8-µm equivalent pore diameter.

C: Polytetrafluoroethylene (PTFE) filter with 3-µm equivalent pore diameter.

D: Polycarbonate capillary pore filter with 1-µm pore size.

3 Determination of equivalent pore diameter

So what is the pore size of a filter? For the capillary pore filter, the pore size is relatively straightforward: the pores are circular and reasonably uniform and run straight through the filter material, so the pore size is the diameter of the pores. This is what many people imagine when they think of the pore size. However, the other types of filters do not have these simple pore structures. The filter material forms intricate paths, and the airstream lines twist and turn as they pass through the filter. Thus, because these filters do not have an obvious, simple dimension that characterizes their pores, an “equivalent pore diameter” is used to describe the filters. This provides a useful way to categorize filters with different sized openings and to ensure consistent performance characteristics. When a manufacturer specifies the pore size of

a filter, they are giving the actual pore diameter for capillary pore filters and the equivalent pore diameter for other types of filters.

The equivalent pore diameter is commonly measured by a “bubble-point test” [ASTM 2011]. This test is fairly simple, is non-destructive, and provides a good quality-control check for the filter. A bubble-point test works like this: Imagine that you have an ideal capillary pore filter with smooth holes that are of a uniform diameter, as shown in Figure 2. Now imagine that there is air on one side of this filter and a liquid that wets the filter on the other side. If the air pressure is low, the surface tension of the liquid will stop the air bubble from being pushed through the filter. If you slowly increase the air pressure, at some point it will be high enough to overcome the surface tension, and a visible stream of air bubbles will be produced. This pressure is called the bubble point. The pore diameter can be calculated from the bubble-point pressure with this formula [Brock 1983]:

$$D = \frac{4\gamma \cos \theta}{P} \times 10^6 \quad \text{(Equation 1)}$$

Where:

- D = pore diameter (micrometers)
- P = bubble-point air pressure (Pa)
- γ = surface tension of the liquid (N/m)
- θ = contact angle between the liquid and the filter material

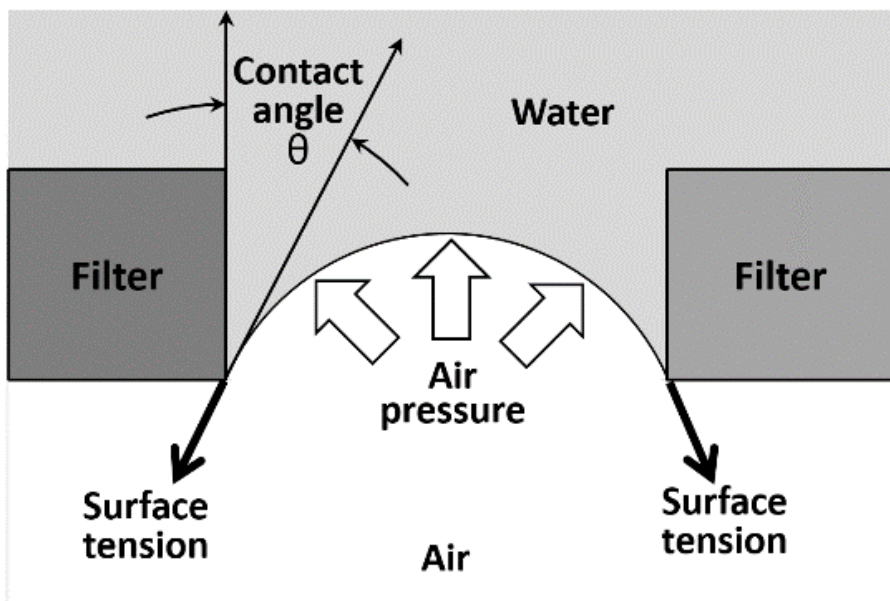

Figure 2: Principle of the bubble-point test.

Note that as the pore diameter gets smaller, more air pressure is required for air to bubble through the ideal filter (Figure 3). Thus, you could take your actual filter and see how much air pressure is needed to bubble air through it. You could then calculate the pore size of an ideal filter that requires the same amount of air pressure to form bubbles as does your actual filter using Equation 1. The pore size of an ideal filter with the same bubble point as your actual filter is the “equivalent pore diameter” of your filter.

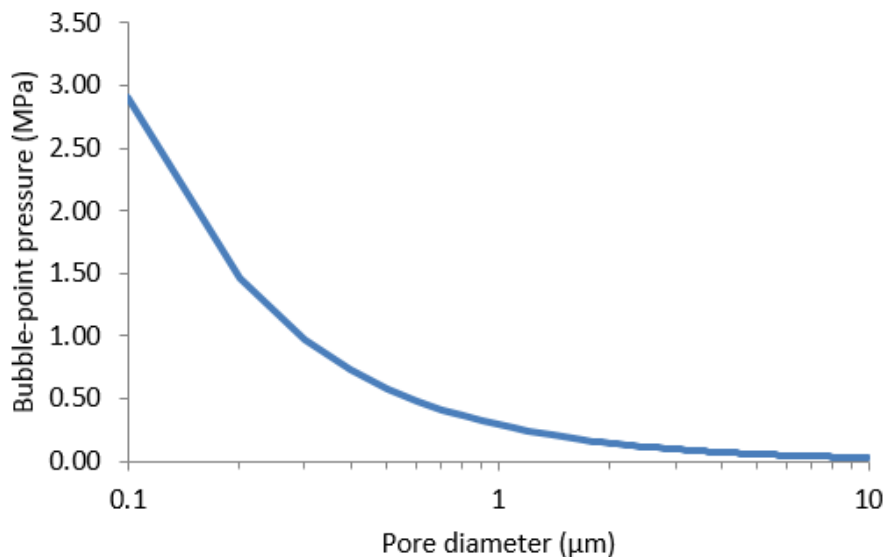
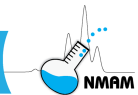

Figure 3: Pore diameter vs. air pressure for ideal filter in bubble-point test. The curve was calculated with use of water (which has a surface tension of 72.8 mN/m) as the liquid. It is assumed that the water completely wets the filter material, and thus the contact angle $\theta = 0^\circ$. Calculated using Equation 1.

Two things should be observed at this point. First, because less air pressure is required to push bubbles through larger openings than through smaller ones, the bubble-point test indicates the size of the largest pores in the filter, not the average pores. For this reason, the bubble-point test is useful for quality control checks of filters, since it will indicate if defects or excessively large pores are present. However, if the filter has a wide range of pore sizes, most of the pores will be smaller than the equivalent pore diameter determined by this test.

Second, the equivalent pore diameter provides a convenient reference point for describing and comparing filters of the same type, but not of different types. For example, the openings in a porous membrane filter with a 5-µm equivalent pore diameter will be somewhat larger than the openings in a porous membrane filter with a 1-µm equivalent pore diameter. However, the pore sizes of different types of filters cannot be meaningfully compared; a capillary filter with a 1-µm pore size bears little resemblance to a porous membrane filter with a 1-µm equivalent pore diameter.



4 How an aerosol filter collects particles

Now that you understand how the equivalent pore diameter is determined, let's discuss how this relates to aerosol sampling. First, we need to review how aerosol sampling filters collect airborne particles. People often assume that a filter works like a sieve—that is, that a filter is like a sheet or mesh with holes of a particular size, and that particles larger than the holes collect on the filter while particles smaller than the holes pass through it. In fact, aerosol filtration is far more complex than this simple model would suggest, and one consequence is that aerosol filters can efficiently collect particles much smaller than would be expected on the basis of the pore size of the filter.

When an airstream containing airborne particles passes through a filter, the particles are collected by five mechanisms (Figure 4):

- 1) *Interception*: Interception occurs when a particle moving with the airstream contacts the filter material. Intercepted particles include those that are bigger than the filter pores (sieving), and also particles that are smaller than the pores but are carried close enough to touch the surface of the filter as they follow the airstream. The closer the diameter of the particle is to the diameter of the opening in the filter, the more likely interception is to occur. Interception can be very important in the collection of fibers and other irregularly shaped aerosol particles because an elongated particle is more likely to come in contact with the filter, especially if it is sideways to the flow or if it is tumbling [Issacs et al. 2005].
- 2) *Impaction*: Impaction occurs when the airstream changes direction abruptly and the inertia of a particle causes it to continue in its original direction and collide with the filter material. Impaction is analogous to an insect hitting the windshield of a car driving on a highway: the air molecules can quickly change direction and move up and over the car, but the inertia of the insect causes it to change direction more slowly and impact the windshield. The likelihood that a particle will deposit by impaction increases proportionally with the density, velocity and diameter² of the particle. Impaction usually is most important for larger particles (around 1 μm and larger) because of their greater inertia.
- 3) *Diffusion*: Brownian motion causes small aerosol particles to move randomly and disperse within an airstream. If the particles collide with the filter material, they can deposit on it. Diffusion is most important for particles of around 0.1 μm and smaller.
- 4) *Electrostatic attraction*: Aerosol sampling filters may carry an electrostatic charge, which can attract charged airborne particles. Charged filter materials can also attract neutral particles by inducing a dipole within the particle, and charged particles can be attracted to

neutral filter materials by image forces (forces created when a charged particle induces an opposite charge in the filter material). This mechanism is especially important for electret-treated filters (filters treated to have permanent electrostatic charges).

- 5) *Sedimentation*: Sedimentation (or settling) occurs when particles fall onto filter materials because of gravitational forces. Sedimentation is generally significant only for very large particles, very slow flow velocities, or if the air is flowing downward into the filter. Because of this, few particles are collected by sedimentation during most workplace aerosol sampling.

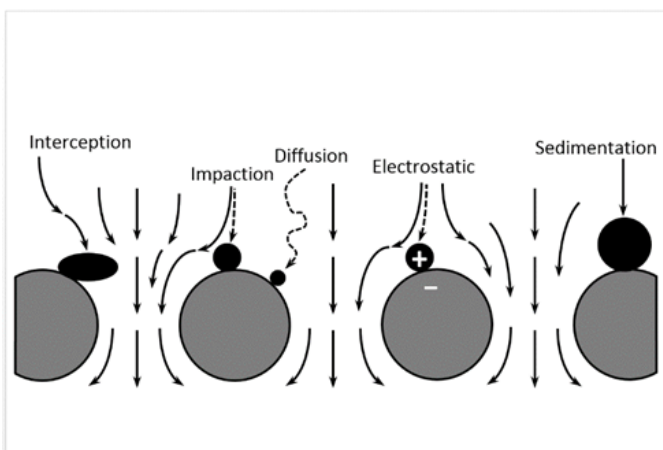

Figure 4: Aerosol particle collection mechanisms. Different types of filters have different structures but they all collect particles using the mechanisms shown here. The relative importance of the various collection mechanisms depends upon the size, shape, density and electrostatic charge of the aerosol particles and the velocity of the air flow through the filter.

An example of the collection efficiencies due to each mechanism for different aerosol particle sizes is shown in Figure 5. The effectiveness and relative importance of these mechanisms depend upon many factors. For example, a higher flow velocity favors impaction by increasing the momentum of the particles, whereas a lower velocity allows more time for particles to diffuse to the filter surface. A highly charged filter and/or aerosol will encourage electrostatic deposition. Fibers and particles with irregular shapes or branching structures are more likely to be intercepted. The filter collection efficiency remains high for nanoparticles from 10 nm down to at least 2 nm; it is thought that the collection efficiency for nanoparticles smaller than 2 nm may decrease due to thermal rebound, but this is still being investigated [Givehchi and Tan 2014; Wang and Tronville 2014].

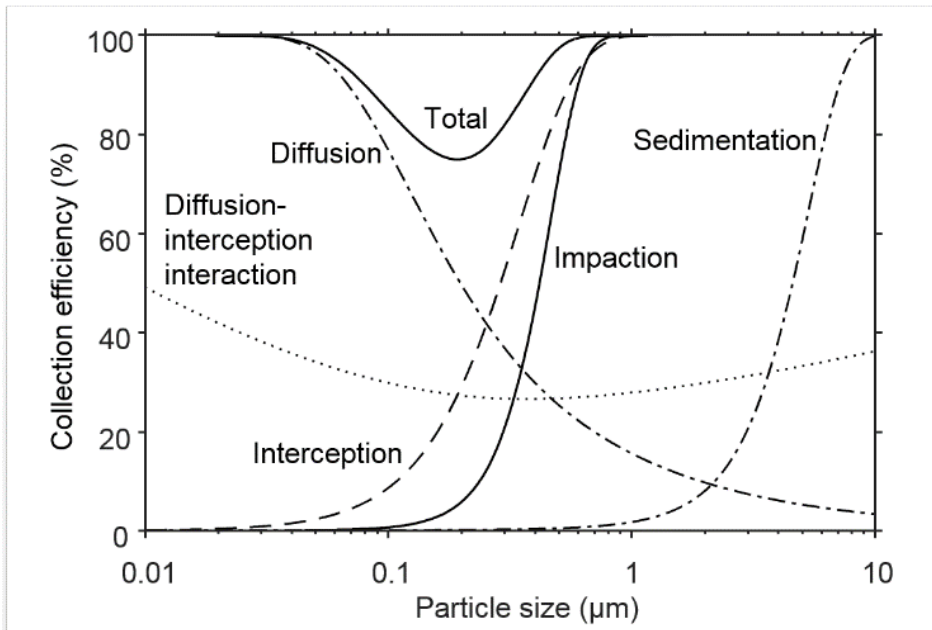

Figure 5: Theoretical collection efficiencies of aerosol particle collection mechanisms for a fibrous filter 1 mm thick with 2 μm fibers and an air velocity of 10 cm/sec. Diffusion-interception interaction is the particle collection due to an enhancement of interception by particle diffusion. The filter surface is assumed to be horizontal with air flowing downward into it, which enhances sedimentation. Total shows the collection efficiency of the filter due to all mechanisms combined. Electrostatic collection is not included because it is very difficult to model. These calculations were based on “single-fiber efficiency” for filters, which is explained in more detail in Hinds [1999]. Figure is adapted from Hinds [1999].

5 Aerosol filter efficiency and pore size

Now, with these collection mechanisms in mind, think about the structures of the different filter types shown in Figure 1. The fibrous and porous membrane filters do not have simple, well-defined pores like a sieve or a simple mesh. Instead, these filters have pathways with a broad range of sizes and a variety of irregular shapes. Thus, particles entering these filters are forced to follow a meandering path, which greatly increases the likelihood that the particles will be intercepted, impact on the filter, or diffuse onto it. For this reason, the probability that a particle will be collected by one of these filters is much higher than one might think based simply on the stated pore size (which is the equivalent pore diameter of the filters). The capillary pore filters provide a more direct pathway through the filter, but even in this case interception, impaction, and diffusion act to collect particles smaller than the sizes of the pores because of the deposition mechanisms discussed in the previous section and shown in Figure 4.

The effect of the structures of these filters and the aerosol particle collection mechanisms that we have discussed can be seen in Figure 6. This plot shows how well particles of different sizes are collected by porous membrane filters, which have tortuous flow paths with equivalent pore diameters of 0.3 and 3 μm , and capillary pore filters with pore diameters of 1 and 3 μm . Note that for all particle sizes, the collection efficiency was $\geq 99.7\%$ for the 0.3- μm porous membrane filter and $\geq 98.4\%$ for the 3- μm porous membrane filter, even though the test particles were much smaller than the equivalent pore diameters of the filters. The collection efficiencies of the capillary pore filters were substantially lower, but these filters were also able to collect particles much smaller than their pore sizes. This can also be seen in Figure 7, which shows submicron NaCl aerosol particles collected using a 3- μm porous membrane filter. These results clearly illustrate that the equivalent pore diameter of a filter does not indicate the size of the airborne particles that the filter will collect and that the structure of the filter has a much greater effect on the collection characteristics.

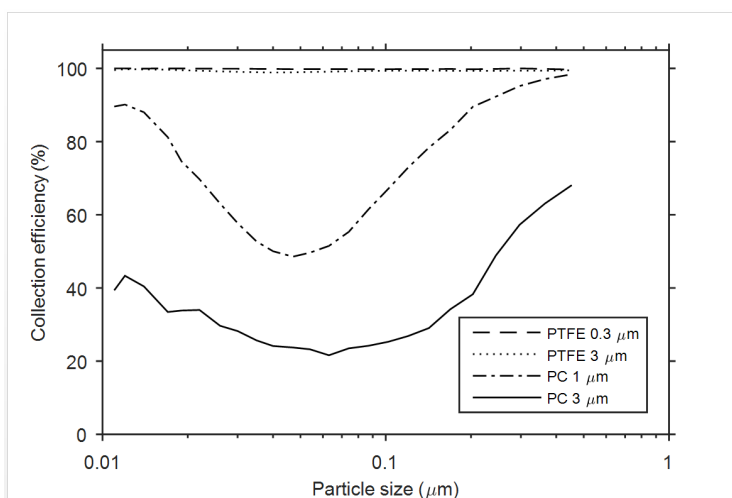

Figure 6: Aerosol particle diameter vs. collection efficiency for polytetrafluoroethylene (PTFE) porous membrane filters with 0.3- μm and 3- μm equivalent pore diameters, and polycarbonate (PC) capillary pore filters with 1- μm and 3- μm pore sizes. The differences in performance are not due to the different materials used for the filters, but rather because the porous membrane filters have tortuous paths which greatly increase the likelihood of particle deposition, while the capillary pore filters have pores that are straighter and smoother. The collection efficiency is the percentage of the particles in the airstream that are collected by the filter. The face velocity (average flow velocity of air into the filter) was 3.5 cm/s for the 0.3- μm PTFE filter and 16 cm/s for the others. The aerosol particles were NaCl. Figure is adapted from Burton et al. [2007].

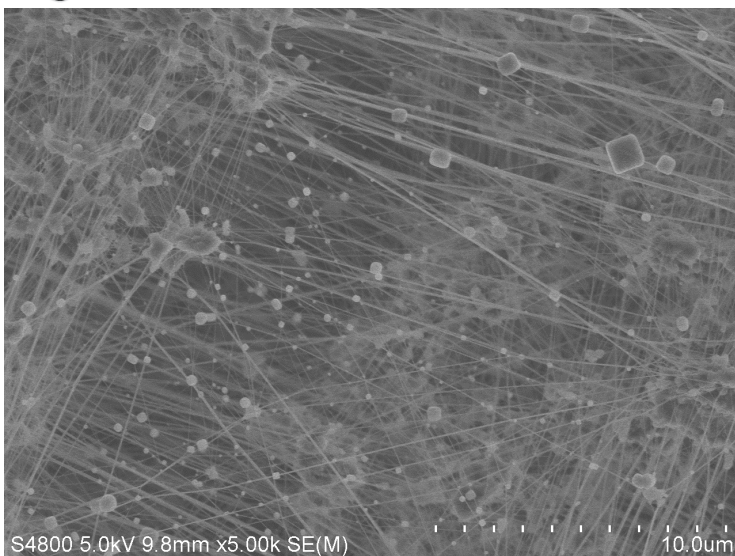
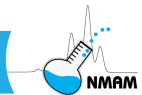

Figure 7: NaCl aerosol particles collected using a PTFE porous membrane filter with a 3- μm equivalent pore diameter at a face velocity of 8.3 cm/s. As can be seen, particles much smaller than 3 μm were captured by the filter.

It is also of interest to note that the collection efficiencies of the capillary pore filters decreased as particle size decreased down to 0.047 and 0.063 μm , and then increased as the particle sizes decreased further. This phenomenon is seen with other types of filters as well. As seen in Figure 5, this occurs because impaction decreases as the particle size decreases, which causes the overall collection efficiency curve to dip downward. However, as particles become even smaller, diffusion becomes a more important collection mechanism, and the collection efficiency increases. The particle size for which the collection efficiency is lowest is called the “most penetrating particle size”, or MPPS. The MPPS for a given filter will vary depending upon the air flow rate, the electrostatic charges of the particles and the filter, the amount of particles that are deposited on the filter, and other factors [Lee and Liu 1980; Martin and Moyer 2000].

6 Significance of pore size

So why is it important to understand pore size? First, an investigator may assume incorrectly that an aerosol sample collected by a filter includes only particles larger than the stated pore size of the filter, when in fact the filter collected smaller particles as well. This can lead to a misinterpretation of test results and a misunderstanding of the actual size characteristics of the aerosol being sampled. An investigator also might wrongly try to use a filter with a particular stated pore size as a pre-filter to remove larger particles before collecting a sample; in this case, many smaller aerosol particles would be removed as well, and the true exposure to small particles could be badly underestimated.



Second, it may be mistakenly thought that two filters with the same stated pore size have the same particle collection characteristics. In fact this is not at all true for filters of different types, as seen in Figure 6: the collection efficiency of a porous membrane filter with a given equivalent pore diameter can be much higher than a capillary pore filter with the same stated pore size.

Third, a filter with a smaller pore size usually has a higher resistance to flow (and therefore a higher pressure drop across the filter) than does a filter of the same type with a larger pore size [Breuer 2012]. Thus, an aerosol sampling pump has to create a stronger vacuum to pull air at the same flow rate through a filter with a smaller pore size. If a filter with a very small pore size is selected on the erroneous belief that the small pore size is needed to collect all of the airborne particles, then the pump may not be able to reach the desired flow rate or may not be able to maintain the desired flow rate as the filter becomes loaded with particles and the flow resistance increases. This may cause the collected sample to be smaller than expected. If the sampling pump is battery powered, its running time may be greatly reduced, and the pump may even shut down prematurely.

7 Filter selection

Given all of this, what is the best way to select an aerosol filter for a particular application? The first step is to consider the purpose of the sampling and how the samples will be processed. For example, polycarbonate capillary pore filters are often used when samples are to be examined using scanning electron microscopy (SEM). Fibers are typically collected using mixed cellulose ester filters, which can be rendered transparent for counting by phase-contrast microscopy. Alkaline dusts are collected using PTFE filters, which allow for analysis by titration. For gravimetric analysis, filters that are not hygroscopic and that have stable weights, such as PVC, are needed. The characteristics of the aerosol particles to be collected also influence the choice of filter. Bioaerosols, for example, may lose viability due to damage or desiccation when collected onto filters. Liquid aerosol droplets behave in much the same manner as solid particles while airborne, but once they are collected the liquids can coat the fibers and coalesce into larger droplets, which can reduce the collection efficiency of a filter [Charvet et al. 2010; Contal et al. 2004]. In addition, oils can mask the charged regions of electret-treated filters, which can greatly reduce the collection of particles by electrostatic mechanisms [Barrett and Rousseau 1998].

The next step is to see if a recommended test method has been published for the aerosol particles of interest. Organizations such as the National Institute for Occupational Safety and Health (NIOSH), the Occupational Safety and Health Administration (OSHA), the Environmental Protection Agency (EPA), the American Conference of Governmental Industrial Hygienists (ACGIH), and ASTM International (formerly known as the American



Society for Testing and Materials) publish test methods for a variety of aerosols that include the characteristics of the filters to be used. For example, in the NIOSH Manual of Analytical Methods, Method 0600 for respirable particle sampling specifies the use of a size-selective cyclone and a “5.0- μm pore size, polyvinyl chloride filter or equivalent hydrophobic membrane filter supported by a cassette filter holder (preferably conductive.)” The NIOSH Manual of Analytical Methods also has several chapters discussing different aspects of aerosol sampling, including general considerations and factors affecting aerosol sampling, sampling bioaerosols, sampling airborne fibers, sampler wall losses, and avoiding bypass leakage in filter cassettes [NIOSH 2003; NIOSH 2014].

If a test method is not available, the collection characteristics of different types of filters can be found in reference texts such as those by Lippmann [2001] and Raynor et al. [2011]. A search of the scientific literature also can produce the results from the testing of various filters to collect different kinds of airborne particles. For example, information on the flow resistance of many types of filters and sampling tubes can be found in Breuer [2012], and Soo et al. [2016] recently tested 29 commercially available aerosol filters and reported their flow resistances and collection efficiencies. Filter manufacturers often provide data on the collection characteristics of their filters and on recommended filters for various applications. Finally, it is important to note that filter collection performance can vary with the flow rate and aerosol particle characteristics as well as the filter type and manufacturer. Thus, care should be taken when applying results from one sampling situation to a different set of conditions.

8 Conclusion

The equivalent pore diameter provides a helpful way to categorize filters and to test for consistency in filter characteristics. However, it should not be construed as an indication of the sizes of aerosol particles that will be collected by the filters. A better understanding of the meaning of the term pore size, the structures of the different types of filters, and the mechanisms by which aerosol particles are collected will help in selecting a filter for a particular application and to correctly interpret the results of aerosol sampling.

Acknowledgements

The author thanks Giles Barton of GE Healthcare and Leonid Turkevich, Nancy Burton, Stephen Martin and Seleen Collins of NIOSH for their advice and assistance. The filter images were taken by Diane Schwegler-Berry of NIOSH.

Disclaimer

Mention of any company or product does not constitute endorsement by NIOSH. In addition, citations to websites external to NIOSH do not constitute NIOSH endorsement of the



sponsoring organizations or their programs or products. Furthermore, NIOSH is not responsible for the content of these websites. All web addresses referenced in this document were accessible as of the publication date.

9 References

- ASTM [2011]. Standard test methods for pore size characteristics of membrane filters by bubble point and mean flow pore test. ASTM F316 - 03(2011). West Conshohocken, PA: ASTM.
- Barrett LW, Rousseau AD [1998]. Aerosol loading performance of electret filter media. *AIHA J* 59(8):532-539.
- Breuer D [2012]. Flow resistance of samplers for personal monitoring in work areas and requirements for sampling pump performance. *J Occup Environ Hyg* 9(2):D25–D32.
- Brock TD [1983]. *Membrane filtration: a user's guide and reference manual*. Madison, WI: Science Tech.
- Burton NC, Grinshpun SA, Reponen T [2007]. Physical collection efficiency of filter materials for bacteria and viruses. *Ann Occup Hyg* 51(2):143–151.
- Charvet A, Gonthier Y, Gonze E, Bernis A [2010]. Experimental and modelled efficiencies during the filtration of a liquid aerosol with a fibrous medium. *Chemical Engineering Science* 65(5):1875-1886.
- Contal P, Simao J, Thomas D, Frising T, Callé S, Appert-Collin JC, Bémer D [2004]. Clogging of fibre filters by submicron droplets. Phenomena and influence of operating conditions. *J Aerosol Sci* 35(2):263-278.
- Givehchi R, Tan Z [2014]. An overview of airborne nanoparticle filtration and thermal rebound theory. *Aerosol Air Qual Res* 14(1):45-63.
- Hinds WC [1999]. *Aerosol technology: properties, behavior, and measurement of airborne particles*. New York: John Wiley & Sons.
- Isaacs KK, Rosati JA, Martonen TB [2005]. Mechanisms of particle deposition. In: Ruzer LS, Harley NH, eds. *Aerosols Handbook Measurement, Dosimetry, and Health Effects*. Boca Raton, FL: CRC Press, pp. 75-99.



Lee KW, Liu BYH [1980]. On the minimum efficiency and the most penetrating particle size for fibrous filters. *Journal of the Air Pollution Control Association* 30(4): 377-381.

Lippmann M [2001]. Filters and Filter Holders. In: Cohen BS, McCammon CS Jr., eds. *Air Sampling Instruments for Evaluation of Atmospheric Contaminants*. Cincinnati, OH: American Conference of Governmental Industrial Hygienists, pp. 281-314.

Martin SB Jr., Moyer ES [2000]. Electrostatic respirator filter media: filter efficiency and most penetrating particle size effects. *Appl Occup Environ Hyg* 15(8):609-617.

NIOSH [2003]. NIOSH manual of analytical methods (NMAM). 4th ed., 3rd supplement. Schlecht PC, O'Connor PF, eds. Cincinnati, OH: U.S. Department of Health and Human Services, Centers for Disease Control and Prevention, National Institute for Occupational Safety and Health, DHHS (NIOSH) Publication 2003-154 [<http://www.cdc.gov/niosh/docs/2003-154/>].

NIOSH [2014]. NIOSH manual of analytical methods (NMAM). 5th ed. Ashley K, O'Connor PF, eds. Cincinnati, OH: U.S. Department of Health and Human Services, Centers for Disease Control and Prevention, National Institute for Occupational Safety and Health, DHHS (NIOSH) Publication No. 2014-151 [<http://www.cdc.gov/niosh/nmam/>].

Raynor PC, Leith D, Lee KW, Mukund R [2011]. Sampling and analysis using filters. In: Kulkarni P, Baron PA, Willeke K, eds. *Aerosol measurement : principles, techniques, and applications*. Hoboken, NJ: John Wiley & Sons, pp. 107-128.

Soo J-C, Monaghan K, Lee T, Kashon M, Harper M [2016]. Air sampling filtration media: Collection efficiency for respirable size-selective sampling. *Aerosol Sci Technol* 50(1):76-87.

Wang J, Tronville P [2014]. Toward standardized test methods to determine the effectiveness of filtration media against airborne nanoparticles. *Journal of Nanoparticle Research* 16(6):1-33.



NIOSH Manual of Analytical Methods (NMAM), 5th Edition

Measurement of Fibers

by Paul A. Baron, Ph.D., NIOSH

Adapted from Baron [2001]

The NMAM team gratefully acknowledges Chen Wang, Joe Fernback and Alan Dozier for insightful review of this chapter.

| | | |
|-----------|--|--------------|
| 1 | Introduction | FI-2 |
| 2 | Fiber dimensions | FI-5 |
| 3 | Phase contrasting light microscope counting (PCM) | FI-6 |
| 4 | Polarizing light microscopy (PLM) of bulk materials | FI-14 |
| 5 | Electron microscopy | FI-17 |
| 6 | Scanning electron microscopy (SEM) | FI-18 |
| 7 | Transmission electron microscopy (TEM) | FI-18 |
| 8 | Optical detection (light scattering) | FI-20 |
| 9 | Fiber classification | FI-21 |
| 10 | Conclusions | FI-22 |
| 11 | References | FI-23 |



**Centers for Disease Control
and Prevention**
National Institute for Occupational
Safety and Health



1 Introduction

Fiber-related disease has provided much of the impetus for fiber research in recent years. Asbestos has been the fiber type most commonly associated with disease. The name “asbestos” is a commercial term applied to the fibrous forms of several minerals that have been used for similar purposes and includes chrysotile, amosite, crocidolite, and the fibrous forms of tremolite, anthophyllite, and actinolite. The three primary diseases associated with asbestos exposure are asbestosis, the result of inflammation and collagen formation in lung tissue; lung cancer; and mesothelioma, an otherwise rare form of cancer associated with the lining surrounding the lungs. A current theory describing the toxicity of fibers indicates that fiber dose, fiber dimension, and fiber durability in lung fluid are the three primary factors determining fiber toxicity [Lippmann 1990].

The dose, or number of fibers deposited in the lungs, is clearly an important factor in determining the likelihood of disease. Both fiber diameter and length are important in the deposition of fibers in the lungs and how long they are likely to remain in the lungs. Figure 1 indicates some of the factors that determine fiber deposition and removal in the lungs. Fiber length is thought to be important because the macrophages that normally remove particles from the lungs cannot engulf fibers having lengths greater than the macrophage diameter.

Thus, longer fibers are more likely to remain in the lungs for an extended period of time. The macrophages die in the process of trying to engulf the fibers and release inflammatory cytokines and other chemicals into the lungs [Blake et al. 1997]. This and other cellular interactions with the fibers appear to trigger the collagen buildup in the lungs known as fibrosis or asbestosis and, over a longer period, produce cancer as well. Fiber diameter is also important because fiber aerodynamic behavior indicates that only small diameter fibers are likely to reach into and deposit in the airways of the lungs. The smaller the fiber diameter, the greater its likelihood of reaching the gas exchange regions. Finally, fibers that dissolve in lung fluid in a matter of weeks or months, such as certain glass fibers, appear to be somewhat less toxic than more insoluble fibers. The surface properties of fibers are also thought to have an effect on toxicity. Asbestos is one of the most widely studied toxic materials and there have been many symposia dedicated to and reviews of its behavior in humans and animals [Selikoff and Lee 1978; Rajhans and Sullivan 1981; WHO 1986; ATSDR 1990; Dement 1990].

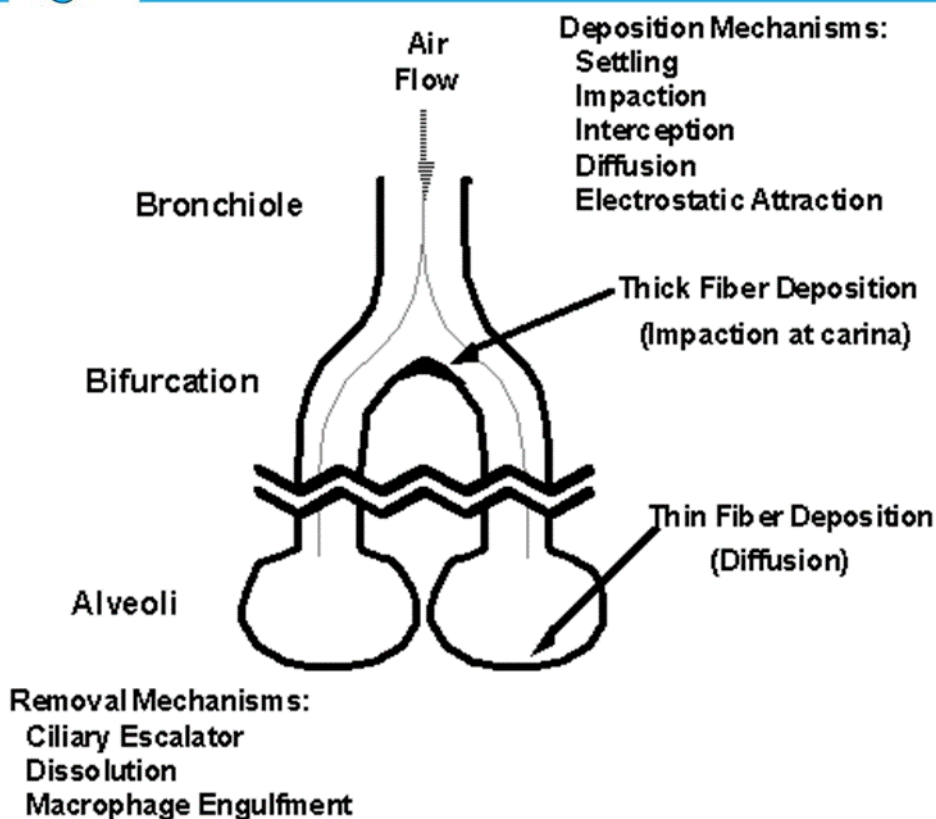

Figure 1. Schematic of mechanisms that affect fiber deposition and retention in the lungs. The deposition depends on all the indicated parameters in a complex fashion. However, larger diameter particles are affected more by gravitational settling, impaction, and interception, resulting in greater deposition further up in the respiratory tract. The saddle points, or carinae, in the branching respiratory tree are often a focal point for deposition of larger diameter fibers. Smaller diameter particles are affected more by diffusion and can collect in the smaller airways and gas exchange region (alveoli). Particle removal from the lungs is primarily effected by the cilia coating the non-gas exchange regions of the lungs; the cilia push mucus produced in the lungs and any particles trapped in the mucus out of the lung and into the gastrointestinal tract in a matter of hours or days. Some fibers are sufficiently soluble in lung fluid that they can disappear in a matter of months. Finally, white blood cells or macrophages roam the gas exchange regions and ingest particles deposited there for removal through the lymph system. Human macrophages are approximately 17 μm in diameter and can only ingest particles smaller than they are. Therefore, thin fibers are likely to deposit in the gas exchange region and, of these, the long insoluble fibers can remain in the lungs indefinitely.

Several techniques were used for asbestos measurement up until the late 1960s [Rajhans and Sullivan 1981]. Earlier than this, it was not widely recognized that the fibrous nature of asbestos was intimately related to its toxicity, so many techniques involved collection of airborne particles and counting all large particles at low magnification by optical microscopy. Thermal precipitators, impactors (konimeters), impingers, and electrostatic precipitators were all used to sample asbestos. Perhaps the primary technique in the United States (US) and the United Kingdom (UK) during this early period was the liquid impinger, in which particles of dust larger than about 1- μm aerodynamic diameter were sampled at 2.7 L/min and impacted into a liquid reservoir [Rajhans and Sullivan 1981]. After sampling, an aliquot of the liquid was placed on a slide in a special cell, particles larger than 5- μm size were counted, and the results were reported in millions of particles per cubic foot. Dissatisfaction with this approach stemmed from lack of correlation between measured particle concentration and disease in the workplace. Various indices of exposure have been developed that attempt to relate a portion of the fiber size distribution to the toxic effects. The appropriate indices for each of the asbestos related diseases as a function of fiber length and diameter (Figure 2) were suggested by Lippmann [Lippmann 1988].

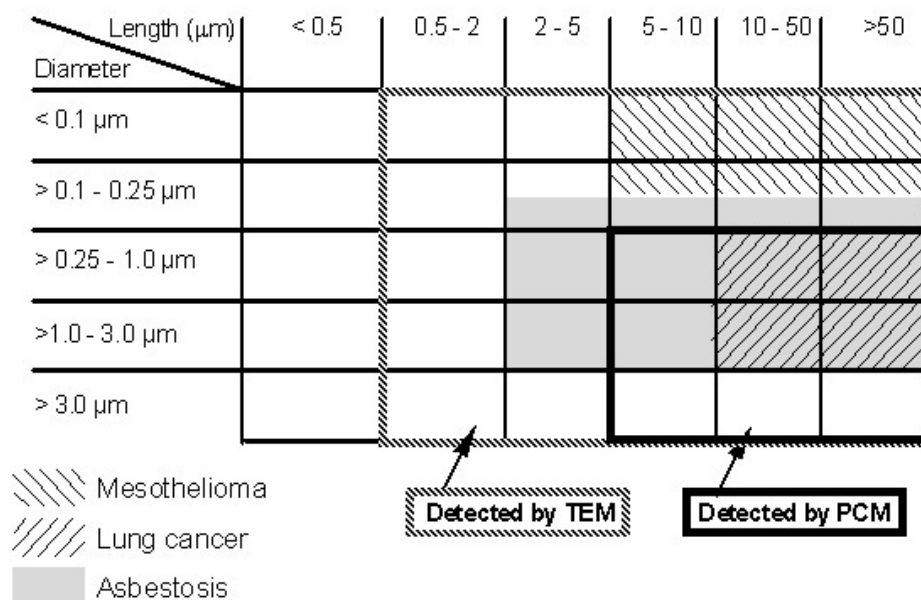

Figure 2. Comparison of proposed size ranges of asbestos fibers causing specific diseases compared with the fiber sizes detected using TEM and PCM techniques. Lung cancer and mesothelioma are more likely to occur at current occupational and environmental levels than asbestosis. PCM can cover only a portion of the total fiber distribution; PCM is used as an indicator of total exposure. TEM can cover the entire size range, but most methods emphasize one size range over another through selection of magnification and counting rules.



2 Fiber dimensions

Fibers are particles that have one dimension significantly larger than the other two. Fibers are often characterized or selected according to their aspect ratio, i.e., the ratio of the large dimension to one of the small dimensions. If no other criteria are used, then materials that might not normally be considered fibrous may contain a fraction of particles that meet the criteria for fibers. The distribution of fiber dimensions in a sample can usually be characterized by assuming a cylindrical geometry (i.e., the two small dimensions are identical) and measuring the length and diameter of individual fibers. The distribution of airborne fiber sizes generated by grinding bulk material or by mechanically releasing particles into the air often results in a two-dimensional (bivariate) lognormal distribution. Such a distribution is characterized by five parameters: the geometric mean length, the geometric mean diameter, the length and diameter geometric standard deviations, and a correlation term that relates length to diameter [Schneider et al. 1983]. In addition, several other parameters that are a function of length and diameter, such as aerodynamic diameter, can also be characterized by a lognormal distribution [Cheng 1986].

Often the discussion of fibers assumes that fibers are straight objects that can be well defined by several parameters as indicated above. However, many real-world particles are not so simple to describe. In fact, the detailed features of many fibers can aid in their identification [McCrone 1980]. Fibers are often curved, have splayed ends, or differ in other ways from a cylindrical shape. Asbestos mineral is composed of fibrils (about 0.03- μm diameter) that are packed together. This fibrillar structure is characteristic of asbestiform minerals. When the mineral is broken apart mechanically, the material separates primarily between fibrils and the resulting fibers are usually bundles of fibrils. The ends of the fibers can be broken apart, with smaller bundles or individual fibrils spread apart, yet still be part of the fiber. Fibers can be contaminated by attachment of other dust particles, creating a complex structure with aerodynamic behavior not matching that of cylindrical fibers. The complexity of fiber shapes affects all of the measurement and separation techniques described below and frequently makes it difficult to compare one method to another.

In addition to asbestos fibers, there are many types of fibrous materials being produced for commercial purposes. These include fibrous glass, mineral wool, refractory ceramic fibers, wood and other plant fibers, and synthetic organic fibers. Most of these fibers tend to have larger diameters than asbestos fibers. On the other hand, carbon nanotubes (CNTs) (<0.005 μm diameter) have recently been produced in small-scale commercial quantities and because of their high tensile strength, high conductivity, and other special properties, show great promise as a commercial material [Liu et al. 1998]. Unlike asbestos fibers, which have discrete lengths and diameters (i.e., aspect ratios), CNTs occur mainly as entangled particle agglomerates and may contain varying amounts of amorphous carbon and residual catalyst



metal. The complexity and variety of structures makes CNT particle counting a challenge. Measurement techniques must be tailored to the size distribution and physicochemical properties of these materials.

This review primarily relates to measurement of fibers in air. There are several techniques that address concentration of asbestos and other fibers in bulk material and measurement of mass concentration of fibers [Beard and Rook 2001]. One of these bulk methods, polarizing light microscopy, will be discussed below.

3 Phase contrasting light microscope counting (PCM)

As asbestos-induced disease became widely studied in the 1960s, cellulose-based membrane filter sampling was applied to asbestos sampling in combination with high magnification phase contrast light microscopy (PCM) for counting fibers. This technique involved collection of fibers uniformly over the surface of a cellulose ester filter, placing the filter or a segment of the filter on a microscope slide and making it transparent, and observing the fibers in the sample with a high magnification (~450X) phase contrast light microscope. Over the years, many researchers have endeavored to improve and standardize the PCM method. One researcher, Walton, discussed many aspects of this technique in a review [Walton 1982]. The high variability of the analysis results and the method's dependence on operator technique made method improvement and research difficult. The PCM method does not measure all fibers; typically only those $>0.25 \mu\text{m}$ diameter are visible and counted and only those $>5 \mu\text{m}$ length are counted by protocol. Therefore, the PCM method is only an index of exposure and uses the assumption that what is detected is correlated with the fibers actually causing disease (Figure 2). The PCM method does not allow identification of asbestos fibers. This is an important limitation when the method is used in settings where fiber concentrations with a significant non-asbestos fraction may occur. This should be remembered when considering some of the parameters discussed below. The aim of evaluating changes to the PCM technique may depend on whether consistency with other laboratories within a country or throughout the world is more important than making measurements that are more closely related to health effects. A number of factors which influence analysis results have been investigated, including the following:

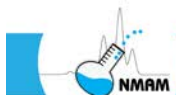

a. Microscope-related parameters

1.) Microscope magnification

The exact level of microscope magnification depends on microscope design, but most current methods use 450X ($\pm 10\%$) total magnification. Pang and coworkers investigated 1250X magnification to improve fiber detectability, but this has not been adopted in any established methods [Pang et al. 1989]. Pang also investigated the effect of using lower magnification (400X) and found that counts were lower for chrysotile asbestos by 25%, but that amosite fiber counts were unaffected [Pang 2000].

2.) Phase contrast optics

This contrast enhancement technique allows detection of asbestos fibers down to about 0.25 μm diameter for chrysotile and about 0.15 μm for amphiboles. Other techniques such as dark field microscopy may offer improved detectability, but also increase the background from non-fibrous particles.

3.) Test slide to check optics

A test slide was developed to allow a check of proper alignment and magnification in the microscope [LeGuen et al. 1984]. This ensures a reasonable level of uniformity in microscope setup and operation, including the operator's visual perception. Improper setup can reduce detectability of fibers. There have also been cases where the optics were "too good," and results were obtained that were higher than the reference count.

4.) Counting area in microscope field

Some early measurements with the phase contrast microscope were made using a rectangular graticule for defining the counting area, while others were made using the entire microscope viewing area. It was found that larger viewing areas resulted in lower counts, so the Walton-Beckett graticule [Walton and Beckett 1977] was developed that nominally gave a 100- μm diameter counting area (the area is calibrated more precisely for each microscope) and has been incorporated in all current methods.

b. Sample preparation techniques

1.) Filter type

Virtually all measurements are made using 0.8- μm pore size mixed cellulose ester (MCE) filters. Some measurements are made using 1.2- μm pore size filters when sampling low concentrations to allow higher flow rate through the filter. Smaller pore size filters are used to ensure that fibers are deposited as near the surface of the filters as possible. This results in fibers ending up in the same plane so that they can be readily viewed with a minimum change of focus during fiber counting. Pore sizes

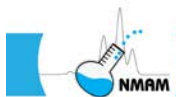

smaller than 0.8 μm are only used with line-operated pumps because of limited suction power available with personal sampling pumps.

2.) Selection of the liquid for making filter transparent

A liquid is placed on the filter that closely matches the filter refractive index, yet has an index that is as far as possible from that of the fibers being detected. Rooker et al. showed that refractive index difference between cleared filter and fibers translated directly into detectability of small diameter fibers [Rooker et al. 1982]. A viscous solution of dimethyl phthalate and diethyl oxalate mixed with cellulose filter material was commonly used in the 1970s and early 1980s. However, it did not result in a permanent sample, with crystallization of the mount and movement of fibers often occurring several days after sample preparation. Permanent slides were needed for quality assurance purposes and the sample preparation technique was also slow and required some skill. A rapid acetone-based filter clearing technique was developed that could be used safely in field situations [Baron and Pickford 1986]. After clearing, filters were coated with triacetin to surround the fibers. This resulted in a longer lasting sample (typically months to years) and is currently specified in most methods. Another technique uses a resin called Euparal to surround the fibers and results in a permanent slide preparation [Ogden et al. 1986].

3.) Filter loading

The number of fibers on the filter is usually specified to be within a certain loading range to ensure consistent counting. Cherrie et al. demonstrated using a serial dilution technique that counting efficiency was a function of concentration of fibers on the filter [Cherrie et al. 1986]. At very low filter loadings (<100 fibers/ mm^2) there was a tendency to count high relative to an intermediate range of concentrations (100-1300 fibers/ mm^2), where the counts were a linear function of loading. This “overcounting” was apparently due to greater visibility of fibers in a clean visual field. This effect was noted for both human counters and an image analysis system. At high filter loadings (>1300 fibers/ mm^2), undercounting occurred due to overlap of fibers with other fibers and with nonfibrous particles. Most published methods indicate that optimum counting occurs within the 100-1300 fibers/ mm^2 range, while some restrict the range further to less than 650 fibers/ mm^2 .

4.) Fiber counting rules

The basic fiber counting rules for most current methods indicate that a countable fiber should be longer than 5 μm , narrower than 3 μm , and have an aspect ratio greater than 3:1. These rules were selected because shorter fibers were difficult to detect by optical microscopy and the 3:1 aspect ratio was used to discriminate between fibrous and non-

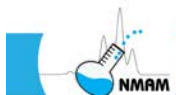

fibrous particles in occupational settings. There has been a great deal of controversy over these rules. The use of a longer fiber cutoff, e.g., 15-20 μm , has been suggested, based on two separate arguments: first, that most asbestos fibers are relatively long and thin (with high aspect ratio) and the longer fiber cutoff would discriminate better toward fibers that were truly asbestos fibers according to mineralogical definitions [Wylie 1979]; and second, that fibers that enter the lungs are removed readily by macrophages if they are shorter than about 15 μm [Blake et al. 1997]. Longer fibers cannot readily be engulfed by macrophages, thus staying in the lungs for a long period and causing continuing fibrosis.

The aspect ratio criterion has also been questioned because many non-asbestiform particles have shape distributions that include particles with aspect ratios greater than 3:1. Since asbestos and other minerals often contain single crystal particles not in the asbestiform habit, it has been argued that these single crystals, or cleavage fragments, should not be counted. However, the Occupational Health and Safety Administration (OHSA) has supported the 3:1 minimum aspect ratio through legal precedent. The National Institute for Occupational Safety and Health (NIOSH) has noted that because of the great difficulty in differentiating whether individual high aspect ratio particles are cleavage fragments or asbestiform fibers, all such particles should be counted. These high aspect ratio particles may cause disease whether or not they are asbestiform.

Other aspects of fiber counting have been investigated, including how to count non-standard fiber shapes, overlapping fibers, overlapping compact particles on fibers, and bundles of fibers. Each of these factors can have a noticeable effect on the final count. Cowie and Crawford investigated the effect of some of these factors and estimated most of them made a difference in the final count on the order of 20% [Cowie and Crawford 1982]. Many of the methods currently in use have slight variations in their interpretation of which fibers to count and thus can contribute to variation in results between countries and organizations.

NIOSH Method 7400 contains two sets of counting rules, the A and the B rules. The A rules are used for asbestos and are consistent with counting rules in previous NIOSH methods. The A rules are required for asbestos counting by OSHA because of legal precedent in regard to the 3:1 aspect ratio rule. The A rules do not have an upper diameter limit for fibers to be counted. The B rules were introduced as an alternative to the A rules when Cowie and Crawford found that these rules agreed best with previous PCM counts, yet had improved precision [Cowie and Crawford 1982]. The B rules have been informally adopted for use with fibers other than asbestos because these rules include the upper diameter limit of 3 μm . This upper diameter limit

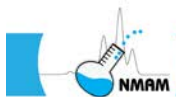

significantly reduces the counting of typically large-diameter fibers, e.g., glass and cellulose, which are unlikely to deposit in the lungs [Breysse et al. 1999].

c. Quality assurance schemes

1.) Sample recounts

Most methods require individual counters to recount about 10% of the field samples to ensure consistent counting procedures and alert the analyst in the case of problem samples. It is also recommended that counters have samples that are routinely recounted to ensure consistent counting within a laboratory over time.

One of the difficulties in analyzing errors made by analysts during PCM counting is that individual fields are difficult to relocate after the analyst has finished counting a slide. Differences in counts between analysts have often been ascribed to local variations in loading on the filter. Pang's development of a slide coverslip that defines counting areas on the sample solves this problem [Pang 2000]. Areas on the coverslip are vacuum coated with a thin layer of gold and platinum using an electron microscope grid as a mask. This leaves defined areas on the coverslip that can be located by grid index marks. Thus, specific fields in a sample can be readily located. Using this grid mapping approach, the location, orientation and shape of each fiber can be noted and differences in counts can be reconciled on a fiber-by-fiber basis. The coverslips have been used to study fiber counting accuracy by comparing routine counting of specified fields to counts agreed upon by a group of competent counters. It was found that the principal errors for chrysotile fiber samples were due to missing fibers close to the visibility limit, while the principal errors for amosite fiber samples were caused by incorrectly sizing fiber length near the 5- μm limit. The chrysotile samples were therefore typically undercounted (negative bias), while the amosite samples had increased variability with individual counters being biased either high or low. Both these errors can be reduced by training counters with pre-counted reference slides prepared using Pang's coverslips [Pang 2000] (Omega Specialty Instrument Co. Chelmsford MA). In addition, these reference slides can be used on a routine basis to ensure consistency in counting. These coverslips or modified versions show great promise for training analysts and perhaps for improving quality assurance schemes.

2.) Interlaboratory sample exchanges

Crawford et al. found that use of sample exchange programs was more important in ensuring agreement between laboratories than similarity in details of the counting rules [Crawford et al. 1982]. Thus, exchange of field samples between laboratories is commonly performed to improve consistency of counting. A description of several quality assurance techniques for asbestos fiber counting is described by Abell et al.

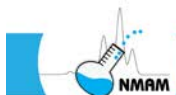

[Abell et al. 1989]. To fulfill Method 7400 requirements for an interlaboratory sample exchange, Tombes and Calpin have described a simple approach using appropriate statistical tests [Tombes and Calpin 2002].

3.) Quality check samples

In order to get agreement between laboratories within a country or internationally, several programs send out identical samples to participating laboratories to assess their relative performance [Schlecht and Shulman 1986; Kauffer 1989; Crawford et al. 1992; Arroyo and Rojo 1998]. These programs provide feedback, often tied to laboratory accreditation, which provides incentive for laboratories to ensure that their performance is similar to that of other laboratories.

d. Qualitative fiber analysis

In addition to simply counting the fibers, there are techniques available for providing at least tentative identification of fiber type; use of these techniques is commonly called differential counting. Fiber shape can be used to limit the type of fiber counted. For instance, glass fibers tend to be straighter, with smoother sides than chrysotile fibers. Polarizing light techniques can also be used to identify larger diameter ($> 1 \mu\text{m}$) fibers. These are based on the optical properties of the materials, including refractive index and crystallinity. These techniques can provide quite positive identification for the presence of certain types of fibers, but are limited in application to airborne fibers because they only work for the larger diameter fibers. These techniques are often used in analysis of bulk materials [NIOSH 1994a]. The use of identification techniques is not allowed in reporting fiber counts using Method 7400 so that the results are consistent between laboratories. Considerable confusion has been caused in the past by individual laboratories using some of these identification techniques to change the counting procedure and, hence, the final results.

Several PCM fiber counting methods have been published by national [NHMRC 1976; HSE 1990] and international organizations [Asbestos International Association 1979; WHO 1997]. Most countries have methods very similar to the ones referenced here.

e. Sampling volume for asbestos abatement applications

Sampling for asbestos after abatement requires the selection of a sampling volume so that one can have high confidence that the air meets acceptable concentration standards. The following is an example of how to calculate this sampling volume.

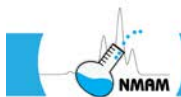

The approach assumes that one wishes to select sampling parameters in order to have a high degree of confidence that a target exposure standard (e.g. NIOSH REL, OSHA PEL, EPA clearance standard) is met.

Several factors need to be established in order to perform this calculation if the target exposure standard involves clearance monitoring. The U.S. Environmental Protection Agency (EPA) authorizes the use of PCM for some clearance monitoring applications and specifies that a level of 0.01 fibers/mL be met. On the method synopsis page, Method 7400 indicates that the limit of detection (LOD) for PCM analysis is 5.5 fibers/100 fields. This is based on intralaboratory variability. A major difference between Method 7400 and other analytical methods in the NIOSH Manual of Analytical Methods (NMAM) is that there is no reference method for Method 7400. Therefore, the consensus mean is the “true” value and the interlaboratory results effectively define the method accuracy. Under the heading “Evaluation of Method, B. Interlaboratory comparability,” Method 7400 provides a means of calculating the confidence limits on a single analysis result (Equations 3 and 4). From Equation 3, the interlaboratory variability at the LOD is such that the upper 95% confidence limit on a measured value is 300% greater than (or 4 times) the measured value.

Using the upper confidence limit, the equation in Section 21 in Method 7400 can be used to estimate the sampling volume.

$$\frac{\frac{\text{number of fibers}}{\text{area of 100 fields}} * \text{total filter area}}{\text{sampling volume}} = \frac{\text{target level}}{4}$$

With the appropriate values inserted, the equation becomes

$$\frac{\frac{5.5 \text{ fibers}}{0.785 \text{ mm}^2} * 385 \text{ mm}^2}{\text{sampling volume}} = \frac{0.01 \frac{\text{fiber}}{\text{mL}}}{4}$$

Solving this equation for sampling volume gives 1080 L. This is the minimum volume that will give a result allowing a single sample to indicate compliance with the 0.01 fiber/mL limit with 95% confidence. It requires that the sample give a result less than or equal to the LOD or 5.5 fibers per 100 fields. A higher fiber count may still indicate that the concentration meets the target level, but not with the same level of confidence. This is likely to be a conservative estimate of concentration and additionally ensure compliance with the standard because the fiber concentration is low and, as indicated above, low fiber

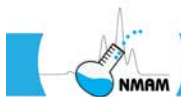

loadings are usually overestimated. However, the background concentration of non-fibrous dust on the filter also must be low to ensure that fibers are not obscured.

f. Other techniques

Since fiber counting by human analysts produces relatively high biases and variability, several researchers have attempted to develop automated counting systems. With the increases in computer power over the last 25 years, it has been tempting to assume that fiber counting is a solvable problem and significant efforts have been made to develop such a system. The most intensive effort to produce a fiber counting system was carried out by Manchester University in collaboration with the Health and Safety Executive in the UK [Kenny 1984]. The Manchester Asbestos Program (MAP) was able to give reasonably good agreement with human counters for certain types of samples. It was used as a reference analyst for the US and UK reference sample programs for several years. Eventually, the MAP was dropped as the reference because it was not sufficiently consistent for all types of samples.

The principle problems with image analysis of asbestos fibers include: the complexity of many fiber shapes, including bundles, agglomerates, and split fibers; the fibers often go in and out of the plane of focus; the background includes many particles and other non-fibrous shapes; the phase contrast optics produces haloes around particles in the sample that can be detected as fibers; and finally, and perhaps most importantly, the contrast between the fibers and background is poor and many fibers are near the detection threshold. An evaluation of the MAP program indicated that a significant fraction of the fibers were misidentified as multiple fibers, not detected at all, and groups of compact particles or edges of large particles were detected as fibers [Baron and Shulman 1987].

Inoue and coworkers have more recently developed image analysis software using a microprocessor-based PC [Inoue et al. 1998]. Initial tests indicate that it works approximately as well as human counters. Inoue also evaluated how well human counters and the image analyzer did in detecting the same fibers in a sample and found that only about 50% of the fibers were consistently counted by all counters, so the image analysis system did approximately as well as the human counters [Inoue et al. 1999]. Further testing of the image analysis system is needed.

In addition to image analysis, optical microscopy can be enhanced using a personal computer to more easily observe the image and to mark and measure fiber dimensions, with automatic recording of the fibers counted [Lundgren et al. 1995]. This does not appear to improve the counting accuracy since the analyst still decides which fibers are to be counted.

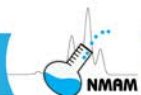

4 Polarizing light microscopy (PLM) of bulk materials

(Adapted from Baron [1993])

The asbestos fibers in bulk material can be released and become airborne when the bulk material is disturbed. For this reason, it is desirable to measure the asbestos content of bulk samples. PLM is often used to determine the percent asbestos in bulk material. The EPA [Asbestos-containing materials, 1987] has defined asbestos containing material (ACM) as material containing more than 1% asbestos using the PLM method, which effectively estimates concentration by area observed. Some confusion exists regarding the units of asbestos percentage. EPA originally indicated that the limit for ACM was 1% by mass [Asbestos-containing materials, 1987], but because of the difficulties in determining corrections for differences in material density and in determining particle volumes, the limit was changed to 1% by area as determined by the PLM method [EPA 1990b]. OSHA does not specify units for percent asbestos in its regulations [OSHA 1994].

Several PLM techniques are used for identifying fiber type as well as semi-quantifying the percent fibrous material (usually asbestos) in a sample [McCrone et al. 1978; Middleton 1979; Asbestos-containing materials, 1990; Perkins and Harvey 1993; NIOSH 1994a]. These techniques depend on particle shape, the refractive index, and other optical properties of individual particles. Many of these PLM techniques require visual observation of color in the fiber and become less reliable for fibers thinner than about 1 μm [Vaughan et al. 1981].

a. Sampling

Several procedures have been suggested for obtaining representative bulk samples of ACM in a fashion that prevents unnecessary exposure to asbestos aerosol [EPA 1985a,b; Jankovic 1985]. Representative sampling of commercial ACM materials is often problematic; these materials may vary significantly in asbestos concentration between nearby locations and even at different depths at the same location. Sampling from multiple locations and compositing samples helps improve the likelihood of obtaining a representative sample.

The material should be wetted or sealed during sample removal. A small coring device, such as a cork borer, can be used to obtain a sample from the full depth of the material. At least three samples per 1000 ft^2 of ACM should be taken [Asbestos-containing materials, 1987]. The sample should be placed in a well-sealed, rugged container. Finally, the sampled area should be repaired or sealed to minimize further fiber release.

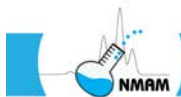

Surface sampling has been proposed by several groups, but there is no relationship between airborne fibers and those found on surfaces [Chatfield 2000]. Therefore, surface sampling for fibers is not recommended.

b. Sample preparation analysis

Sample preparation for a PLM analysis involves grinding the material to the optimum particle size range (1-15- μm diameter) and dispersing the particles in a liquid of known refractive index on a glass slide [Perkins and Harvey 1993]. Particle size uniformity in the prepared sample is extremely important. A few large chunks of material may contain more asbestos than hundreds of much smaller particles. Friable material, i.e., that which is crumbly or can be crushed by hand, may readily release fibers and is considered more hazardous. Friable materials are generally easier to prepare for analysis than some other ACMs, such as vinyl asbestos floor tiles, which may require dissolution or ashing of the matrix material so that the fibers are separated and visible in the microscope. Before and after preparation, the sample is observed with a stereomicroscope at 10-100X magnification to evaluate sample uniformity and observe whether fibrous material is present.

Some materials that interfere with accurate fiber identification either by their similarity or by covering up the fibers can be removed by physical treatment of the sample. For instance, organic materials, such as cellulose fibers or diesel soot can be removed by low temperature, oxygen-plasma ashing [Baron and Platek 1990]. Leather fibers and chrysotile have a similar appearance and refractive index. The leather can be removed by ashing at 400°C [Churchyard and Copeland 1988].

Fiber morphology, i.e. the structure and shape of the fiber, can be used to assist in its identification. Morphology of fibers can give some indication of fiber type. For instance, chrysotile fibers tend to be curly, while amphibole fibers are straight, especially when they are shorter than 50 μm . Asbestos fibers often have frayed or split ends, while glass or mineral wool fibers are typically straight or slightly curved with fractured or bulbous ends. Many plant fibers are flattened and twisted, with diameters between 5-20 μm . Note that it is not recommended to base identification solely on morphology.

Fiber refractive index and other crystalline properties can be used to identify fiber type with reasonable certainty. Several techniques for determining these properties can be used in a polarizing light microscope. When viewed in the microscope with crossed polarizing filters, isotropic (isometric or amorphous) fibers appear consistently bright when rotated, while anisotropic (uni- or biaxial crystal structure) fibers appear bright, but disappear when rotated to their extinction angle, which is a function of crystal structure. Thus,

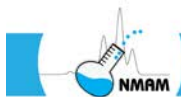

amorphous materials such as glass or mineral wool fibers can easily be discriminated from asbestos.

During PLM analysis, fibers are immersed in a fluid selected to have a known refractive index. When a fiber has a larger refractive index than the surrounding fluid medium, the bright halo (Becke line) around that fiber appears to move into it as the microscope focus is raised; when the fiber has a smaller refractive index, the Becke line moves out of it. Placing the fibrous material into several different refractive index fluids allows the fiber refractive index to be bracketed.

Dispersion, or refractive index change with wavelength, of a fiber can be used for identification. When particles are placed in a liquid whose dispersion is different from that of the particle, the particle may exhibit a color caused by the refraction of light. This technique requires the use of special "dispersion staining" optics. By using several refractive index liquids in series, the refractive index and the dispersion of the fiber can be established and compared with those of standard materials or published data [McCrone 1980].

Once the sample has been uniformly dispersed on a slide in the appropriate refractive index liquid, specific fiber types, e.g., asbestos, can be identified and the percent fibers estimated. Two approaches are typically used: visual comparison with prepared reference slides or pictures and point counting. When attempting to estimate whether a material is ACM (i.e., > 1% asbestos), the visual comparison technique is adequate when more than about 10% of the particles observed are asbestos. Point counting is used for lower concentration samples to provide higher accuracy [EPA 1990a]. It involves observing 400 or more randomly selected "points" (identified with a reticle crosshair) in the sample. The number of points containing asbestos is divided by the total number of points observed to give the percent asbestos. A combination of these approaches balances the analysis time and accuracy of the results [Webber et al. 1990].

PLM also can be used for qualitative analysis of air sample filters by collapsing the filter and using low temperature plasma etching of the surface to expose the fibers. Various refractive index liquids can then be placed on the etched surface to surround the fibers, allowing techniques noted above to be used [Vaughan et al. 1981]. The smallest fibers that can be identified by this method are about 1- μm diameter.

c. Accuracy

PLM analysis is primarily used for qualitative identification of fiber type. Accurate identification of asbestos and other fibers requires proper training in the crystallographic



properties of particles as well as training and familiarization with the PLM. As with fiber counting, a laboratory quality assurance program is necessary to ensure consistently accurate results. The National Voluntary Laboratory Accreditation Program (NVLAP) operated by the National Institute for Standards and Technology (NIST) inspects laboratories for proper practice as well as providing unknown samples four times a year to check their performance in fiber identification. Under a predecessor to this program, approximately 350 laboratories correctly classified 98.5% of the samples as asbestos and correctly identified the specific asbestos types in approximately 97% of the samples. A blind test of 51 laboratories resulted in 97.5% correct classifications and 79.1% correct identifications [EPA 1986]. The American Industrial Hygiene Association Proficiency Analytical Testing Program provides similar PLM audit samples to laboratories. Some common interferences for bulk analysis by PLM include sepiolite, vermiculite, and cleavage fragments of non-asbestos amphiboles.

PLM has been cast in a quantitative measurement role by the EPA requirement of determining whether a school building material meets the 1% asbestos level defining ACM. Many variables including particle size, density and shape are not adequately controlled or measured in the analysis and contribute to errors in the percent mass estimate. Thus, PLM analysis is at best a semi-quantitative technique.

Chatfield indicated that the accuracy of PLM for low concentrations of asbestos was poor and described a set of procedures that concentrated the asbestos into a weighable fraction [Chatfield 2000]. An EPA report describes, in addition to the PLM and Chatfield's gravimetry methods, a TEM and an x-ray diffraction method for bulk analysis of asbestos [Chatfield 2000]. NIOSH Method 9000 describes an x-ray diffraction method for chrysotile [NIOSH 1994c].

5 Electron microscopy

Scanning electron microscopy (SEM) has not been the focus of as much method development as either light microscopy or transmission electron microscopy (TEM). PCM found favor because of the low equipment cost and lower training level required for analysis. TEM is preferred for environmental and research studies because it offers the highest resolution and the most positive identification capabilities. TEM allows visibility of all asbestos fibers down to the individual fibrils, electron diffraction for crystal structure identification, and energy dispersive x-ray analysis for elemental measurement. SEM has intermediate resolution, with many instruments of this type not able to see all asbestos fibers. However, many modern SEMs have the capability of detecting asbestos fibrils, though contrast with background may be poor for some fiber types, especially if a high contrast substrate is not used. Energy dispersive x-ray analysis is also available for many SEMs, providing some qualitative



information of fiber type. However, since electron diffraction typically cannot be performed by SEM, this often leaves open the question of positive identification of fibers.

6 Scanning electron microscopy (SEM)

Particles are observed in the SEM when a beam of electrons is focused onto the sample surface and scanned over an area. The electrons are scattered from the surface and detected above the surface synchronously with the beam scan rate and an image of the scanned surface is created. Thus, the SEM measures the surface of particles on a substrate. The best image can be obtained on conducting objects deposited on a smooth, conducting substrate. Particles are often deposited on aluminum or carbon planchets that fit directly into the SEM or onto polycarbonate membrane (track-etched, Nuclepore®) filters. The samples are usually coated with gold or carbon to increase conductivity.

There have been some SEM methods developed for fiber counting [Asbestos International Association 1984; WHO 1985; ASTM 1996; ISO 2002]. These methods are primarily used for inorganic man-made fibers that have larger diameter fibers than can occur with asbestos. Thus, all the fibers are potentially visible using the SEM.

7 Transmission electron microscopy (TEM)

The transmission electron microscope (TEM) allows detection of particle shape and structure down to the smallest asbestos fibers (Figure 2) and can be used to determine crystal structure from electron diffraction as well as determining elemental composition from energy dispersive x-ray analysis. Although TEM analysis is potentially very powerful and accurate, the process of sample collection and preparation and details involved in sample analysis can degrade the quantitative accuracy of the technique. Several more specialized techniques, such as electron energy loss spectroscopy and secondary ion mass spectrometry, have been used for analyzing particles and can also be applied to fibers [Fletcher et al. 2001].

Airborne fiber samples for TEM analysis are typically collected onto a filter, usually a polycarbonate membrane or MCE membrane filter. For the latter filter type, the filter is chemically collapsed to form a smooth upper surface on which collected fibers are trapped. Sometimes the surface is etched using a low temperature asher to expose the fibers collected on or near the surface of the original filter. The filter is coated with a carbon film that entraps fibers exposed on the filter surface and the filter material is then dissolved away. The carbon film is transferred to a TEM grid (usually 3-mm diameter) and the sample can be placed in the TEM for analysis.



For Method 7402, the surface is not ashed because some fibers, e.g., cellulose, may be removed and give an inaccurate total fiber count [Baron and Platek 1990]. Ashing can thus affect the measurement of the asbestos fiber fraction.

The above approach to preparing MCE filters for TEM analysis is called the direct-transfer approach, since fibers are transferred to the carbon film with minimum disturbance to the way they were collected. An alternative technique is to dissolve the entire filter in liquid, ultrasonicate the suspension to disperse the particles, and deposit an aliquot of the particle suspension onto a polycarbonate filter for final transfer to the carbon film. This is called the indirect-transfer technique. With the indirect technique, the optimum particle loading of the TEM sample can be obtained and soluble particles can be removed from the sample. However, the suspension process can change the apparent size distribution of the particles and fibers by breaking apart agglomerates or even breaking apart asbestos fibers into smaller fibers or fibrils [Sahle and Laszlo 1996]. The breakup problem can be especially severe for chrysotile, causing a large increase in fiber count. Quality assurance is especially important with TEM analysis of fibers. The NVLAP program provides quality assurance accreditation for laboratories performing TEM analysis using the Environmental Protection Agency's Asbestos Hazard Emergency Response Act (AHERA) method. Note that data provided under the AHERA method, because of significant differences in counting rules, the types of structures counted as asbestos, and the size range of fibers, cannot be directly compared with counts by Methods 7400 or 7402.

The process of sample collection and preparation is a complex one that can introduce biases into the final measurement. Since only small portions of the filter are measured during TEM analysis, sampled fibers that deposit non-uniformly onto the filter due to inertial, gravitational, and electrostatic effects will be measured inaccurately [Chen and Baron 1996]. Fibers that penetrate the filter surface and are not transferred to the carbon film will be lost. If the filter is incompletely dissolved away from the carbon film, the sample will be difficult to analyze.

Many of the sources of bias and variability noted in sampling and counting by PCM also apply to TEM analysis. Fiber counting in a TEM can also introduce biases and variability in the final result. There is a tendency to use the high magnification of the TEM to look for the smallest fibers, while ignoring some of the larger ones. Even so, fibers shorter than 0.5 μm tend to be missed because they are difficult to see in the background clutter of the sample [Steel and Small 1985]. Taylor et al. found that TEM counting gave poorer precision than counting the same sample by PCM and recommended that the fraction of asbestos fibers counted by TEM be applied to the PCM count as indicated in Method 7402 [Taylor et al. 1984]. This combined PCM/TEM approach gave better precision than counting by TEM alone.



In addition to recognizing fibrous shape and structure of the several asbestos minerals, qualitative analysis of fibers by TEM primarily involves two techniques, energy dispersive x-ray analysis and electron diffraction. X-ray analysis produces responses for each of the elements (typically atomic number > 6 , but is instrument dependent) present in a particle; the responses occur as peaks in an energy spectrum. Specific asbestos minerals can be identified using peak intensity ratios observed in standard samples and as specified in the method.

The crystal structure of individual fibers is evaluated using electron diffraction. Focusing the TEM electron beam on a single fiber produces a diffraction pattern consisting of a number of spots. The spot locations depend not only on the particle crystal structure, but also on the geometry of the electron beam optics and other instrumental parameters. The diffraction spot locations relative to one another give a very specific identification of crystal structure. For easily recognized minerals, such as chrysotile, the visual identification of the diffraction pattern is often sufficient. However, to identify fibers not fitting the x-ray analysis pattern for standard asbestos minerals, careful measurement, or indexing, of the diffraction spots is important.

The combination of x-ray analysis and electron diffraction gives a highly definitive identification of specific minerals. However, as with any analytical methods, there are exceptions that require greater expertise to recognize potential interferences. Some minerals that are difficult to differentiate from regulated asbestos minerals include non-regulated amphiboles and fibrous talcs. There are several established methods for analyzing fibers, especially asbestos fibers, by TEM [Asbestos-containing materials, 1987; NIOSH 1994b; ISO 1995, 1999; ASTM 1998].

8 Optical detection (light scattering)

Two types of light scattering detectors are commonly used for measuring airborne dust concentrations: the optical particle counter (OPC), which detects and counts individual particles, and the photometer (sometimes called a nephelometer), which detects the scattering from all particles in a defined detection volume. A standard OPC was used to detect asbestos concentrations in a workplace where the aerosol was primarily fibrous and good correlation with fiber counts was obtained [Rickards 1978]. A nephelometer may also be used, but may have an even greater interference from non-fibrous dusts.

The fibrous aerosol monitor (Model FM-7400, MIE, Inc. Bedford MA) used an electrostatic alignment technique by applying a field that aligns and rotates individual fibers in a laser beam. The light scattered from the fibers uniquely identified the presence of individual fibers. This allowed specific detection of fibers [Lilienfeld et al. 1979] and was even used to measure fiber length [Marijnissen et al. 1996].

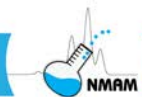

Several field tests have indicated that the fibrous aerosol monitor agrees reasonably well with field measurements of fibers by phase contrast microscopy, though mostly at concentrations above ambient levels. It has been used at abatement sites to provide rapid feedback and ensure acceptable containment of airborne fibers during asbestos removal.

9 Fiber classification

Several devices have been used to measure or separate fibers by diameter. A spiral centrifuge was used to separate fibers and reference spherical particles to estimate fiber aerodynamic diameter [Stöber 1972]. It was found that the aerodynamic diameter was directly proportional to physical diameter, proportional to the square root of the fiber density, and proportional to fiber length to the 1/6th power. For mineral fibers having a density of about 3 g/cm³, the aerodynamic diameter was approximately three to five times the physical diameter of the fiber. Behavior of glass fibers in a cascade impactor was investigated by Burke and Esmen [Burke and Esmen 1978]. A small correction to the aerodynamic diameter was developed to take into account interception of longer fibers with the impaction surface. An inertial spectrometer was used to measure fiber aerodynamic diameter and good diameter separation was achieved [Morigi et al. 1999]. Baron and Deye developed a technique for separating fibers by length using dielectrophoresis [Baron et al. 1994; Deye et al. 1999]. This technique was also shown to be useful for measuring fiber length and diameter distributions [Baron et al. 2000].

As with most airborne dusts, fiber settling will reduce the number of larger diameter fibers in a distribution as the distance from the source of the dust increases. Esmen et al. showed that average fiber concentration in workplaces decreased exponentially with an increase of fiber diameter, indicating that the larger diameter fibers settled out more quickly than smaller diameter fibers [Esmen et al. 1979]. Cyclones, impactors and porous foam classifiers were evaluated for efficiency of removing airborne fibers not likely to deposit in the lungs [Maynard 1996].

The aerodynamic diameter of fibers is dependent primarily on fiber physical diameter and fiber density, with a minor dependence on fiber length [Baron 1996]. The diseases caused by asbestos fibers are lung diseases and so it makes sense to measure only fibers that can enter the lungs, i.e., thoracic fibers. Identical conventions for thoracic samplers have been published by ISO, ACGIH [ACGIH 2002], and CEN. Baron [Baron 1996] showed that sampling fibers with a thoracic sampler was approximately equivalent to counting only mineral fibers with a physical diameter smaller than 3 µm. Jones et al. [Jones et al. 2001] reported that there appeared to be no impediment to using a thoracic sampler for fiber sampling; they found that several samplers matched the thoracic convention, the sample collected by these samplers could be analyzed by standard methods, and that field studies indicated equivalence to the



current method. Maynard [Maynard 1999] also found that there appeared to be no variation in penetration through these samplers as a function of fiber length. The advantage to using a thoracic sampler, apart from adhering to conventional sampling practice, is that it would remove larger compact particles and fibers from the sample and result in a cleaner sample. Although current US practice does not use an upper diameter limit for asbestos fibers, such a limit is commonly used for man-made fibers. Except for the United States, all national and international organization methods use an upper diameter limit of 3 μm for fiber counting of asbestos fibers.

It is likely that thoracic sampling will eventually be in routine use for measurement of asbestos and other fibers. This approach has several advantages. It places the fiber method in line with other dust sampling conventions. It removes some of the larger particles in the sample, resulting in a cleaner sample for the analyst. It removes the need for determining fiber diameter during counting and it is consistent with previous practice of using an upper diameter limit of 3 μm for fiber counting in some methods. Thoracic sampling has the disadvantage of requiring the flow rate for a specific sampler to be fixed. This reduces the flexibility to target the loading of the filter by adjusting the flow rate. However, several classifiers can be designed to operate at selected flow rates to allow some flexibility in sampling.

10 Conclusions

The capability for measurement of fiber size distributions is available through microscopy and, to a much lesser extent, through direct-reading instrumentation. Because of differences in counting rules, resolution capability, and ability to distinguish asbestos from interfering particles or other fibers, PCM, PLM, SEM, and TEM methods often do not produce results which are directly comparable. The traditional methods of microscopy are relatively inaccurate when compared to chemical analysis methods for most other analytes because of the many sources of error in the sampling and analysis procedure. To improve laboratory-to-laboratory agreement, counter training and quality control, including the exchange of samples among laboratories and proficiency testing, are important. Implementation of training through the use of Pang's coverslips allows investigation of counting errors and potential improvement of PCM counting accuracy. Thoracic sampling could eliminate interfering particles and thereby improve measurement methods in the future.



Disclaimer

Mention of any company or product does not constitute endorsement by NIOSH. In addition, citations to websites external to NIOSH do not constitute NIOSH endorsement of the sponsoring organizations or their programs or products. Furthermore, NIOSH is not responsible for the content of these websites. All web addresses referenced in this document were accessible as of the publication date.

11 References

Abell MT, Shulman SA, Baron PA [1989]. The quality of fiber count data. *Appl Ind Hyg* 4:273-285.

ACGIH [2002]. Appendix D: particle size-selective sampling criteria for airborne particulate matter. In: 2002 TLVs and BEIs based on the documentation of the Threshold Limit Values for chemical substances and physical agents and Biological Exposure Indices. Cincinnati, OH: American Conference of Governmental Industrial Hygienists.

Arroyo MC, Rojo JM [1998]. National versus international asbestos fibre counting schemes: comparison between the Spanish Interlaboratory Quality Control Program (PICC-FA) and the Asbestos Fibre Regular Informal Counting Arrangement (AFRICA). *Ann Occup Hyg* 42:97-104.

Asbestos-containing materials in schools. 40 CFR Part 763 Subpart E (1987).

Asbestos-containing materials in schools. 40 CFR Part 763 Subpart E Appendix E (1990).

Asbestos International Association [1979]. Reference method for the determination of airborne asbestos fibre concentrations at workplaces by light microscopy (membrane filter method). Recommended technical method 1 (RTM1). London: Asbestos Information Association.

Asbestos International Association [1984]. Method for the determination of airborne asbestos fibres and other inorganic fibres by scanning electron microscopy. Recommended technical method 2 (RTM2). London: Asbestos Information Association.

ASTM [1996]. D6059-96 Standard test method for determining concentration of airborne single-crystal ceramic whiskers in the workplace environment by scanning electron microscopy. Philadelphia, PA: American Society for Testing and Materials.



ASTM [1998]. D6281-98 Standard test method for airborne asbestos concentration in ambient and indoor atmospheres as determined by transmission electron microscopy direct transfer (TEM). Philadelphia, PA: American Society for Testing and Materials.

ATSDR [1990]. Toxicological profile for asbestos. Atlanta, GA: U.S. Department of Health and Human Services, Centers for Disease Control and Prevention, Agency for Toxic Substances and Disease Registry, TP-90-04.

Baron PA [1993]. Measurement of asbestos and other fibers. In: Willeke K, Baron PA, eds. *Aerosol measurement: principles, techniques, and applications*. New York: Van Nostrand Reinhold.

Baron PA [1996]. Application of the thoracic sampling definition to fiber measurement. *Am Ind Hyg Assoc J* 57:820-824.

Baron PA [2001]. Measurement of airborne fibers: a review. *Ind Health* 39:39-50.

Baron PA, Pickford GC [1986]. An asbestos sample filter clearing procedure. *Appl Ind Hyg* 1:169-171.

Baron PA, Platek SF [1990]. NIOSH method 7402-asbestos fibers (revision#1)--low temperature ashing of filter samples. *Am Ind Hyg Assoc J* 51:A730-A731.

Baron PA, Shulman SA [1987]. Evaluation of the Magiscan image analyzer for asbestos fiber counting. *Am Ind Hyg Assoc J* 48:39-46.

Baron PA, Deye GJ, Fernback J [1994]. Length separation of fibers. *Aerosol Sci Technol* 21:179-192.

Baron PA, Deye GJ, Fernback JE, Jones WG [2000]. Direct-reading measurement of fiber length/diameter distributions. In: Beard ME, Rook HL, eds. *Advances in environmental measurement methods for asbestos*. Philadelphia, PA: American Society for Testing Materials.

Beard ME, Rook HL, eds. [2001]. *Advances in environmental measurement methods for asbestos*. STP 1342. Philadelphia, PA: American Society for Testing Materials.

Blake T, Castranova V, Schwegler-Berry D, Deye GJ, Baron P, Li C, Jones W [1997]. Effect of fiber length on glass microfiber cytotoxicity. *J Tox Environ Health* 54A:243-259.



Breyse PN, Lees PSJ, Rooney BC [1999]. Comparison of NIOSH method 7400 A and B counting rules for assessing synthetic vitreous fiber exposures. *Am Ind Hyg Assoc J* 60:526-532.

Burke WA, Esmen NA [1978]. The inertial behavior of fibers. *Am Ind Hyg Assoc J* 39:400-405.

Chatfield EJ [2000a]. A validated method for gravimetric determination of low concentrations of asbestos in bulk materials. In: Beard ME, Rook HL, eds. *Advances in environmental measurement methods for asbestos*. Philadelphia, PA: American Society for Testing and Materials.

Chatfield EJ [2000b]. Correlated measurements of airborne asbestos containing particles and surface dust. In: Beard ME, Rook HL, eds. *Advances in environmental measurement methods for asbestos*. Philadelphia, PA: American Society for Testing Materials.

Chen C-C, Baron PA [1996]. Aspiration efficiency and wall deposition in the fiber sampling cassette. *Am Ind Hyg Assoc J* 52:142-152.

Cheng Y-S [1986]. Bivariate lognormal distribution for characterizing asbestos fiber aerosols. *Aerosol Sci Technol* 5:359-368.

Cherrie J, Jones AD, Johnston AM [1986]. The influence of fiber density on the assessment of fiber concentration using the membrane filter method. *Am Ind Hyg Assoc J* 47:465-474.

Churchyard MP, Copeland GKE [1988]. Is it really chrysotile? *Ann Occup Hyg* 32:545-547.

Cowie AJ, Crawford NP [1982]. A comparison of the effects of different counting rules and aspect ratios on the level and reproducibility of asbestos fibre counts: part II: effects on reproducibility. TM/82/23. Edinburgh, Scotland: Institute of Occupational Medicine.

Crawford NP, Brown P, Cowie AJ [1992]. The RICE and AFRICA schemes for asbestos fibre counting. *Ann Occup Hyg* 36:59-69.

Crawford NP, Thorpe HL, Alexander W [1982]. A comparison of the effects of different counting rules and aspect ratios on the level and reproducibility of asbestos fibre counts: part I: effects on level. TM/82/23. Edinburgh, Scotland: Institute of Occupational Medicine.

Dement JM [1990]. Overview: workshop on fiber toxicology research needs. *Environ Health Perspec* 88:261-268.



Deye GJ, Gao P, Baron PA, Fernback JE [1999]. Performance evaluation of a fiber length classifier. *Aerosol Sci Technol* 30:420-437.

EPA [1985a]. Asbestos in buildings: simplified sampling scheme for friable surfacing materials. Washington, DC: U.S. Environmental Protection Agency, EPA 560/5-85-030a.

EPA [1985b]. Guidance for controlling asbestos-containing materials in buildings. Washington, DC: U.S. Environmental Protection Agency, EPA 560/5-85-024.

EPA [1986]. Asbestos containing materials in school buildings: bulk sample analysis quality assurance program. Bulk sample rounds 12, 13 and blind round III. Washington, DC: U.S. Environmental Protection Agency, EPA/600/4-86/028.

EPA [1990a]. 40 CFR Part 61. National emission standards for hazardous air pollutants; asbestos. NESHAP revision, final rule. Nov. 20. Washington DC: U.S. Environmental Protection Agency, <http://www.epa.gov>.

EPA [1990b]. 40 CFR Part 61.141 Subpart M. National emission standard for asbestos. Washington DC: U.S. Environmental Protection Agency, <http://www.epa.gov>.

Esmen N, Corn M, Hammad Y, Whittier D, Kotsko N [1979]. Summary of measurements of employee exposure to airborne dust and fiber in sixteen facilities producing man-made mineral fibers. *Am Ind Hyg Assoc J* 40:108-117.

Fletcher RA, Small JA, Scott JHJ [2001]. Analysis of individual collected particles. In: Baron P, Willeke K, eds. *Aerosol measurement: principles, techniques and applications*. New York: John Wiley and Sons, Inc.

HSE [1990]. MDHS 39/3 Asbestos fibres in air. June (revised). London: Health and Safety Executive.

Inoue Y, Kaga A, Yamaguchi K [1999]. Cross-check between automatic counting system and visual counting facilities of asbestos fibers. *J Aerosol Res Jpn* 14:129-137.

Inoue Y, Kaga A, Yamaguchi K, Kamoi S [1998]. Development of an automatic system for counting asbestos fibers using image processing. *Particul Sci Technol* 16:263-279.

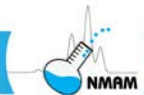

ISO [1995]. ISO 10312 Ambient air-determination of asbestos fibres-direct transfer transmission electron microscopy method. Geneva, Switzerland: International Organization for Standardization.

ISO [1999]. ISO 13794 Ambient air-determination of asbestos fibres-indirect transfer transmission electron microscopy method. Geneva, Switzerland: International Organization for Standardization.

ISO [2002]. ISO 14966 Determination of numerical concentration of inorganic fibrous particles-scanning electron microscopy method. Geneva, Switzerland: International Organization for Standardization.

Jankovic JT [1985]. Asbestos bulk sampling procedure. *Am Ind Hyg Assoc J* 46:B8-B10.

Jones AD, Aitken RJ, Armbruster L, Byrne P, Fabries JF, Kauffer E, Liden G, Lumens M, Maynard A, Riediger G, Sahle W [2001]. Thoracic sampling of fibres. Contact research report 349/2001. Norwich, UK: Health and Safety Executive.

Kauffer E [1989]. The French asbestos quality control scheme. In: Sixth International Colloquium on Dust Measurement Technique and Strategy. Jersey, Channel Islands: Asbestos International Association.

Kenny LC [1984]. Asbestos fibre counting by image analysis-the performance of the Manchester asbestos program on Magiscan. *Ann Occup Hyg* 28:401-415.

LeGuen JMM, Ogden TL, Shenton-Taylor T, Verrill JF [1984]. The HSE/NPL phase-contrast test slide. *Ann Occup Hyg* 28:237-247.

Lilienfeld P, Elterman P, Baron P [1979]. Development of a prototype fibrous aerosol monitor. *Am Ind Hyg Assoc J* 40:270-282.

Lippmann M [1988]. Asbestos exposure indices. *Environ Res* 46:86-106.

Lippmann M [1990]. Effects of fiber characteristics on lung deposition, retention, and disease. *Environ Health Perspec* 88:311-317.

Liu J, Rinzler AG, Dai H, Hafner JH, Bradley RK, Boul PJ, Lu A, Iverson T, Shelimov K, Huffman CB, Rodriguez-Macias F, Shon Y-S, Lee TR, Colbert DT, Smalley RE [1998]. Fullerene pipes. *Science* 280:1253-1256.



Lundgren L, Lundström S, Laszlo I, Westling B [1995]. Modern fibre counting-a technique with the phase-contrast microscope on-line to a Macintosh computer. *Ann Occup Hyg* 39:455-467.

Marijnissen J, Lilienfeld P, Zhou Y [1996]. A laser monitor for the fiber deposition in a lung model. *J Aerosol Sci* 27:S523-S524.

Maynard AD [1996]. The development of samplers for size selective sampling of fibres: phase 2 report: selection and development of personal thoracic samplers. IR/A/96/11. Sheffield, UK: Health and Safety Laboratory.

Maynard AD [1999]. Measurement of aerosol penetration through six personal thoracic samplers under calm air conditions. *J Aerosol Sci* 30:1227-1242.

McCrone WC [1980]. The asbestos particle atlas. Ann Arbor, MI: Ann Arbor Science Publishers, Inc.

McCrone W, McCrone L, Delly J [1978]. Polarized light microscopy. Ann Arbor, MI: Ann Arbor Science Publishers, Inc.

Middleton AP [1979]. The identification of asbestos in solid materials. In: Michaels L, Chissick SS, eds. *Asbestos: properties applications and hazards*. Chichester, UK: John Wiley and Sons, Inc.

Morigi MP, Giacomelli GM, Prodi V [1999]. Mineral fibre sampling and size selection. *Ann Occup Hyg* 43:117-124.

NHMRC [1976]. Membrane filter method for estimating airborne asbestos dust. Woden, Australia: National Health and Medical Research Council.

NIOSH [1994a]. Asbestos (Bulk) by PLM: Method 9002. In: Eller PM, Cassinelli ME, eds. *NIOSH manual of analytical methods*. 4th ed. Cincinnati OH: U.S. Department of Health and Human Services, Centers for Disease Control and Prevention, National Institute for Occupational Safety and Health, DHHS (NIOSH) Publication No. 94-113.

NIOSH [1994b]. Asbestos by TEM: Method 7402. In: Eller PM, Cassinelli ME, eds. *NIOSH manual of analytical methods*. 4th ed. Cincinnati OH: U.S. Department of Health and Human Services, Centers for Disease Control and Prevention, National Institute for Occupational Safety and Health, DHHS (NIOSH) Publication No. 94-113.



NIOSH [1994c]. Asbestos, chrysotile by XRD: Method 9000 In: Eller PM, Cassinelli ME, eds. NIOSH manual of analytical methods. 4th ed. Cincinnati OH: U.S. Department of Health and Human Services, Centers for Disease Control and Prevention, National Institute for Occupational Safety and Health, DHHS (NIOSH) Publication No.94-113.

Ogden TL, Thomson DJ, Ellwood PA [1986]. Euparal and its use in measurement of asbestos. *Microscope* 34:173-179.

OSHA [1994]. 29 CFR 1910.1001b Occupational safety and health standards: detailed procedure for asbestos sampling and analysis - Non-Mandatory. Washington, DC: U.S. Department of Labor, Occupational Safety and Health Administration.

Pang TWS [2000]. Precision and accuracy of asbestos fiber counting by phase contrast microscopy. *Am Ind Hyg Assoc J* 61:529-538.

Pang TWS, Schonfeld-Starr FA, Patel K [1989]. An improved membrane filter technique for evaluation of asbestos fibers. *Am Ind Hyg Assoc J* 50:174-180.

Perkins RL and Harvey BW [1993]. Method for the determination of asbestos in bulk building materials. Washington, DC: Environmental Protection Agency, EPA/600/R- 93/116.

Rajhans GS, Sullivan JL [1981]. Asbestos sampling and analysis. Ann Arbor, MI: Ann Arbor Science Publishers, Inc.

Rickards AL [1978]. The routine monitoring of airborne asbestos in an occupational environment. *Ann Occup Hyg* 21:315-322.

Rooker SJ, Vaughan NP, LeGuen JM [1982]. On the visibility of fibers by phase contrast microscopy. *Am Ind Hyg Assoc J* 43:505-515.

Sahle W, Laszlo I [1996]. Airborne inorganic fibre level monitoring by transmission electron microscope (TEM): comparison of direct and indirect sample transfer methods. *Ann Occup Hyg* 40:29-44.

Schlecht PC, Shulman SA [1986]. Performance of asbestos fiber counting laboratories in the NIOSH Proficiency Analytical Testing (PAT) Program. *Am Ind Hyg Assoc J* 47:259-269.

Schneider T, Holst E, Skotte J [1983]. Size distribution of airborne fibres generated from man-made mineral fiber products. *Ann Occup Hyg* 27:157-171.



Selikoff IJ, Lee DHKE [1978]. *Asbestos and disease*. New York: Academic Press, Inc.

Steel EB, Small JA [1985]. Accuracy of transmission electron microscopy for the analysis of asbestos in ambient environments. *Anal Chem* 57:209-213.

Stöber W [1972]. Dynamic shape factors of nonspherical aerosol particles. In: Mercer TT, Morrow PE, Stöber W, eds. *Assessment of airborne particles*. Springfield, IL: Charles C. Thomas.

Taylor DG, Baron PA, Shulman SA, Carter JW [1984]. Identification and counting of asbestos fibers. *Am Ind Hyg Assoc J* 45:84-88.

Tombes, C, Calpin JA [2002]. A simple quality control system for evaluation of interlaboratory differences in fiber counting in accordance with NIOSH Method 7400. *Am Ind Hyg Assoc J* 49:A695-A697.

Vaughan NP, Rooker SJ, LeGuen JM [1981]. In situ identification of asbestos fibres collected on membrane filters for counting. *Ann Occup Hyg* 24:281-290.

Walton WH [1982]. The nature, hazards, and assessment of occupational exposure to airborne asbestos dust: a review. *Ann Occup Hyg* 25:115-247.

Walton WH, Beckett ST [1977]. A microscope eyepiece graticule for the evaluation of fibrous dusts. *Ann Occup Hyg* 20:19-23.

Webber JS, Janulis RJ, Carhart LJ, Gillespie MB [1990]. Quantitating asbestos content in friable bulk sample: development of a stratified point-counting method. *Am Ind Hyg Assoc J* 51:447-452.

WHO [1985]. *Reference methods for measuring airborne man-made mineral fibres (MMMMF)*. Geneva, Switzerland: World Health Organization.

WHO [1986]. *Asbestos and other natural mineral fibres*. Geneva, Switzerland: World Health Organization.

WHO [1997]. *Determination of airborne fibre number concentration: a recommended method by phase contrast optical microscopy (membrane filter method)*. Geneva, Switzerland: World Health Organization.



Wylie AG [1979]. Fiber length and aspect ratio of some selected asbestos samples. In: Selikoff IG, Hammond EC, eds. Health hazards of asbestos exposure. New York: Annals of the New York Academy of Science.



NIOSH Manual of Analytical Methods (NMAM), 5th Edition

Sampling and Analysis of Soluble Metal Compounds

by **Kevin Ashley, Ph.D., NIOSH** and **Richard Fairfax, CIH, OSHA**

[Much of this chapter was adapted from Fairfax and Blotzer 1994; and Ashley 2001.]

| | | |
|---|--|-------|
| 1 | Introduction | SM-2 |
| 2 | Soluble and insoluble metal compounds | SM-2 |
| 3 | Health effects | SM-4 |
| 4 | Sampling considerations | SM-5 |
| 5 | Analytical considerations | SM-5 |
| 6 | ISO procedure for soluble metals and metalloids | SM-7 |
| 7 | Summary | SM-10 |
| 8 | References | SM-11 |
| 9 | Appendix - Solubilities of selected metals and metal compounds | SM-14 |



**Centers for Disease Control
and Prevention**
National Institute for Occupational
Safety and Health



1 Introduction

Workplace exposure standards have been established for several soluble metals and metalloids to take into account the increased bioavailability of some metal compounds. Exposure standards for soluble compounds can be up to 500 times lower than the exposure standards for less soluble compounds for the same metal. However, there is often confusion among chemists, industrial hygienists, and laboratories over what is meant by “soluble” when the metal species, extraction fluid, or solubility conditions are not specified in the exposure standard nor in the supporting exposure standard documentation [Fairfax and Blotzer 1994]. In addition, the metals and metal compounds may interact chemically or physically with the sampling media or with each other [Ashley 2001]. Such complications can affect the stability and speciation of the metals and their compounds, and must be addressed in order to obtain meaningful results. These issues are becoming more important in workplace airborne metals exposure monitoring.

The solubility of a metal will depend on the chemical form of the metal, the fluid used to extract the metal, and the conditions under which the extraction occurs (e.g., temperature, volume, time). Unfortunately, the degree of method specificity needed to obtain measurements that are reproducible among laboratories is generally either missing or is subject to a variety of interpretations from exposure standards and supporting documentation. The need for a better definition of what is meant by the term “soluble” in relation to exposure standards was first raised in the 1990s, but as of the new millennium no significant improvement had occurred within exposure standard-setting organizations in the United States. Therefore, to meet the needs of analysts, laboratories, and laboratory clients for better definition of the analyte of interest, and to improve measurement reproducibility among laboratories, various organizations are working to achieve international consensus on extraction of soluble metal compounds. Consensus guidelines have been promulgated in an International Standard [ISO 2012a], and this will serve to fill the void and improve the situation.

2 Soluble and insoluble metal compounds

The American Conference of Governmental Industrial Hygienists and several countries (e.g., France, Germany, UK, USA) have established occupational exposure limits (OELs) for soluble metal and metalloid compounds [ACGIH 2015; IFA 2014]. Some examples of elements for which soluble OELs have been promulgated are listed in Table 1 (see Appendix for additional details). For many of these elements (e.g., Tl, Ag, Cr[VI], Ni, Pt), the OELs for the soluble compounds are lower than for the corresponding insoluble forms [ACGIH 2001; CRC 2015].



Table 1. Example metallic elements for which soluble compounds have been assigned OELs [IFA 2014; ACGIH 2015]

| |
|---|
| Aluminum – Soluble compounds, as Al |
| Barium – Soluble compounds, as Ba |
| Chromium – Water-soluble Cr[VI] compounds |
| Iron – Soluble salts, as Fe |
| Molybdenum – Soluble compounds, as Mo |
| Nickel – Soluble compounds, as Ni |
| Platinum – Soluble salts, as Pt |
| Rhodium – Soluble compounds, as Rh |
| Silver – Soluble compounds, as Ag |
| Thallium – Soluble compounds, as Tl |
| Tungsten – Soluble compounds, as W |
| Uranium – Soluble compounds, as U |

a. Solvent

The term “solubility,” as used by analytical chemists, ordinarily pertains to the dissolution of a material in pure water [CRC 2015]. The subject of water solubility of metal compounds is covered in several references [CRC 2015; ACGIH 2001; Beliles 1994; O’Neil 2006]. According to *Patty’s Industrial Hygiene and Toxicology* [Beliles 1994] and the individual ACGIH Threshold Limit Value® (TLV) documentation for these metals [ACGIH 2001], the solubilities of metals and metal compounds are quite variable depending upon the solvent. Other pertinent references sustain the notion that solubility, regarding metals and their compounds, is generally identified in terms of their solubility in water [ACGIH 2001; O’Neil 2006]. The solubility and insolubility of numerous inorganic substances are presented in the Appendix. What is meant by “soluble” depends on the operational definition employed for the extraction conditions desired by the investigator.

b. Temperature

Temperature is another variable that directly affects solubility. Most current analytical methods specify deionized water, but not water temperature (some procedures call for hot water (37 °C), but others use water at room temperature). Some important questions thus arise:

- 1.) If using deionized water, should chemists assure that water temperature has been heated to body temperature (i.e., 37 °C)? For occupational exposure assessment purposes, should solubility be based upon body temperature?



- 2.) Should the OEL value documentation specify that analytical procedures use extraction media heated to body temperature?

3 Health effects

From a health perspective, the solubility of a metal or metal compound is not the only consideration of interest. Ultimately, the most important consideration is the extent to which such soluble metals accumulate in body fluids or target organs, leading to toxic levels of the metal ion. This is of more concern than solubility in water, acids, or alkalis per se. Further complicating the solubility issue is the fact that the term “soluble” may have different meanings among industrial hygienists and chemists. Chemists generally use the term “soluble” as defined by the CRC Handbook of Chemistry and Physics [CRC 2015]. According to the CRC Handbook, a material is considered soluble if a saturated solution in water (at 25 °C) contains more than 1% (m/v); any material in which 1 percent or less is dissolved is considered insoluble. Unfortunately, a material listed as insoluble, using the CRC definition, could still dissolve in body fluids and produce a significant tissue concentration which is biologically detrimental. The point is that an OEL for an “insoluble” compound may not be sufficient to protect exposed workers. When asked in an informal poll to choose a solvent in which to measure the relative solubility of metals, industrial hygienists chose, in order of preference, water, body fluids, and a petroleum solvent [Fairfax and Blotzer 1994].

a. Body fluids

When considering the biological effect of the solubility of a material, we should ideally first consider body fluids. However, body fluids vary considerably in pH. For example, the pH of the stomach is acidic, the pH in the intestine is alkaline, the pH of blood serum is approximately neutral, some macrophages are highly acidic, and the pH of saliva is slightly acidic. Furthermore, body fluids contain a variety of solutes, including salts and polypeptides (proteins). Polypeptide molecules can bind to metal ions in solution and often contain functional groups that can chelate metals. Polypeptides have strong chelating ability in body fluids and will account for the considerable difference between the solubility of a metal in body fluids versus that same metal in water. Metals, in turn, are bound to different proteins, depending upon where in the body they are located at a given time. In passing through the body, a metal ion is bound by different polypeptides. For each of them, a different reaction may be involved. Some reactions may increase or decrease the toxicity of the metal ion.

Because of the effect of proteins, pH, and other solutes in body fluids, the solubility of a metal compound in body fluids will be quite different than the metal’s solubility in water [ACGIH 1987].



4 Sampling considerations

a. Filter reactivity

The filter medium used must not react with the airborne particulate collected by the sampler so as to change the chemical form of the captured sample. This can occur if a soluble compound reacts with the filter material or a contaminant therein to produce an insoluble or less soluble compound. An example of this problem has been observed with silver, where a soluble silver compound, AgNO_3 , can react with chloride in some mixed cellulose ester (MCE) or polyvinyl chloride (PVC) filters to form AgCl , which is much less soluble in water. Thus, low recoveries of “soluble” silver will result unless an alternative filter medium, such as polytetrafluoroethylene (PTFE), is used. Another problem is illustrated by soluble forms of $\text{Cr}[\text{VI}]$, which can react with the filter medium to form insoluble compounds and/or undergo reduction to $\text{Cr}[\text{III}]$ and, therefore, be lost to $\text{Cr}[\text{VI}]$ analysis. Hence, chemical compatibility issues must be investigated before samples meant for “soluble” extraction procedures are taken.

Membrane filters are appropriate for sampling aerosols for subsequent determination of soluble metal compounds. Such filters are manufactured from a variety of polymeric materials by a number of different processes. Choice of polymer material comprising the filter (e.g., MCE, PTFE, PVC) will depend on chemical reactivity issues discussed in the preceding paragraph. The metal content of the filters must be as low as possible, since it can make a significant contribution to the blank value.

5 Analytical considerations

A number of analytical methods for soluble metal compounds in occupational hygiene samples have been published by various organizations [NIOSH 1994; HSE 1998; BIA 1989; INRS 2014]. Efforts to harmonize sample preparation approaches have led to the promulgation of related consensus standards [Ashley 2015].

a. European standard

Guidance on sample preparation methods for soluble metals and metalloids in workplace air has been promulgated recently in a European Standard [CEN 2009]. In these published methods and guidelines [NIOSH 1994; HSE 1998; BIA 1989; INRS 2014], two methodologies are generally favored for the extraction of “soluble” metal species: (1) extraction in pure water, or (2) extraction in diluted (~ 0.1 M) hydrochloric acid (HCl). In the European Standard [CEN 2009], both strategies are given as options for the dissolution of “soluble” metals in workplace air samples. Extraction of metals and metalloids in water is meant to reflect the chemical definition of “soluble” (as mentioned above), while extraction in diluted HCl is designed to mimic the dissolution of “soluble”

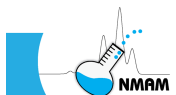

metal compounds in stomach acid, which is highly acidic (pH 1). A temperature of 37 °C is recommended since this is normal body temperature.

b. Extraction solvent

A researcher in Germany [Hahn 2000] argued for the establishment of 0.1 M HCl in an operational definition for soluble metals in occupational hygiene samples and, also, specified mechanical agitation at 37 °C for two hours prior to sample analysis. An exception is made for thallium, which can form insoluble TlCl, in which case HCl is replaced by diluted nitric acid (HNO₃). (A similar problem would arise if HCl were used as the extraction acid for soluble silver compounds.) The German extraction method for several soluble metal species [BIA 1989] is consistent with the strategy outlined [Hahn 2000], which attempts to address bioavailability by choosing HCl as the extraction acid. However, in standard methods promulgated by the United States [NIOSH 1994], the United Kingdom [HSE 1998], and France [INRS 2014], deionized water is the solvent chosen in the operational definition of “soluble” for numerous metallic elements in workplace air samples. An exception to extraction in water is made for nickel [HSE 1998], where an ammonium citrate solution is specified as the leachate for soluble compounds of this element. Ammonium citrate provides buffering and chelating properties that are desirable for leaching soluble nickel compounds [HSE 1998].

c. Operational definitions

Operational definitions of “soluble” metal species have been promulgated for consumer products such as toys, paper products, paints and art materials [ASTM 2014; CEN 2013; ISO 2011]. Standard procedures for the extraction of metal compounds from consumer products are based on sample treatments in 0.07 - 0.14 M HCl (depending on the sample) for an hour at a temperature of 37 °C [Hahn 2000] or at room temperature [CEN 2013]. An ASTM International procedure (formerly the American Society for Testing and Materials) [ASTM 2014] is meant to provide an estimate of the bioavailability of several metals in art materials, using ~0.1 M HCl and extraction at body temperature.

d. Quantity of solvent

Another uncontrolled variable is the quantity of solvent used in laboratory analytical procedures for soluble metals at different laboratories. Different laboratories may (and do) use different amounts of deionized water for extraction. For example, one laboratory might use 10 mL of deionized water to extract the metal from a sample, while another lab may use anywhere from 25 to 100 mL to extract the compound. Depending upon the amount of material present in the sample, the procedure using 25 to 100 mL can dissolve a larger mass of solute than that using 10 mL. A conservative analytical method for metals used 15 mL of deionized water for extraction. This volume was chosen as a convenience



and may not bear any relationship to what the body might absorb. Thus, two identical samples could produce two different results depending on the volume of solvent and other analytical parameters. A further factor affecting solubility is the particle size distribution of the sample: smaller particles are ordinarily more easily dissolved than larger ones. Thus for two samples having the same mass, the sample comprised of small particles may be more easily dissolved than a sample having large particles.

6 ISO procedure for soluble metals and metalloids

Various procedures for the extraction of soluble metals and metalloids have been used for years, based on different operational definitions of solubility. The International Organization for Standardization, Technical Committee 146 on Air Quality, Subcommittee 2 on Workplace Atmospheres, Working Group 2 on Inorganic Particulate Matter (ISO/TC 146/SC 2/WG 2) has attempted to standardize extraction procedures for “soluble” metal compounds by offering an operational definition in terms of a sample preparation method for metallic elements in industrial hygiene measurements.

a. Bioavailability

In the 1990s, it was argued that the solubility in body fluids should be considered in the development of a new definition for soluble TLVs [Fairfax and Blotzer 1994]. But since different body fluids have different solubility characteristics (e.g., pH, salts, polypeptides), such an operational and uniform definition for “bioavailable” cannot realistically be decided. Indeed, the meaning of “bioavailability” has been debated nationally and internationally for years, and it was not deemed practicable nor defensible to attempt to operationally define solubility based on biochemical arguments. Hence, it was decided by consensus within the ISO working group (ISO/TC 146/SC 2/WG 2) to describe procedures for soluble metal compounds in terms of strictly chemical, and not biochemical, criteria [Ashley 2001].

b. Laboratory consistency

With regard to analytical methods for the extraction of soluble metals and their compounds, it was suggested that the extraction media, temperature, and extraction volume should be consistent among all laboratories [Fairfax and Blotzer 1994]. For an operational definition of “soluble” to be offered, delineation of these analytical parameters is necessary in order to fully standardize the extraction procedure for soluble metal species. Moreover, the apparatus used, as well as chemical compatibility issues, must be amply described. Matters that are outside of laboratory control, notably sampling, cannot

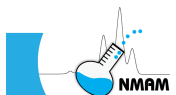

always be adequately influenced; however, recommendations as to sampling media, sample handling, and transport requirements should be provided to the field industrial hygienist.

c. Development of ISO procedure

The ISO working group responsible for the development of ISO 15202-2, ISO/TC 146/SC 2/WG 2, began its task in September 1995, not long after the publication of the aforementioned article [Fairfax and Blotzer 1994]. Shown in Table 2 is a list of countries that participated in voting on the technical content of the draft international standard when it was circulated for balloting, from 1996 to 2000.

Because of the various operational definitions for “soluble” metal compounds, a significant challenge was presented to the ISO working group responsible for the development of an international standard method to describe a procedure for extracting soluble metals and metalloids for subsequent atomic spectrometric analysis. Two choices were available based on the standard methods mentioned above: (1) extraction in pure water, or (2) extraction in 0.1 M HCl. It was decided by consensus of ISO delegates present at the earlier working group meetings to follow the former course, where solubility of metal compounds in occupational hygiene samples is defined in chemical terms. This decision was upheld during the later international voting process, which involved those countries listed in Table 2. Nevertheless, text within the International Standard [ISO 2012a] states that individual countries may specify alternative procedures for the measurement of soluble metal species in workplace air samples. This, then, leaves open the option to use other extraction media, such as 0.1 M HCl.

Table 2. “Participating Member”* Countries of ISO/TC 146/SC 2 (During the period of development of ISO 15202-2 [1996-2000])

| | | |
|---------|-------------|----------------|
| Belgium | Korea | Turkey |
| Germany | Netherlands | United Kingdom |
| India | Poland | United States |
| Italy | Spain | |
| Japan | Sweden | |

* “Participating,” or P-Member, countries are those nations able to vote on Draft International Standards, and therefore may provide comments on the technical content of the documents during voting. “Observing,” or O-Member, nations (not listed) may also offer comments and can participate in the development of ISO standards. However, in the formal ISO voting process, O-member nations can vote only on Final Draft International Standards, which allows only for editorial, and not technical, changes at this stage.



The ISO procedure for soluble metals and metalloids assumes that samples were collected using the International Standard for the collection of workplace air samples for subsequent multi-element analysis, ISO 15202-1 [ISO 2012b]. However, the choice of filter material used for the collection of samples targeted for the “soluble” metals procedure is important. Annex A of ISO 15202-1 [ISO 2012b] and Annex B of ISO 15202-2 [ISO 2012a] provide useful guidance on this subject.

The “soluble” metals procedure described in ISO 15202-2 [ISO 2012a] lists all of the elements in Table 1 except for Cr[VI] and Fe. Nevertheless, the sample preparation protocol described in this International Standard is certainly applicable to these other two metallic elements as well. The ISO “soluble” metals method [ISO 2012b] calls for treatment of collected workplace filter samples in 5 mL of deionized water (or ammonium citrate leach solution in the case of Ni) and mechanical agitation in a water bath at 37 ± 2 °C for 60 min. Undissolved material is thereafter separated from the sample solution using a suction filtration apparatus or a syringe filter, and ensuring use of filtration materials that are unreactive towards the soluble metal compounds of interest. After filtration, the sample solution is acidified with nitric acid in order to stabilize the dissolved metallic elements within the extracted sample. This test sample is then ready for analysis by ICP-AES (or ICP-mass spectrometry [ICP-MS] if very low detection limits are required). Of course other analytical techniques, e.g., atomic absorption spectrometry [Wang et al. 2000; Draper et al. 1999] or electrochemical analysis [Ashley 1994; Draper et al. 1999], can be used as analytically equivalent alternatives.

d. Method performance

The performance of soluble extraction methods has been evaluated for several soluble metal species, e.g., those of nickel, silver and hexavalent chromium. Soluble extraction and atomic spectrometric analysis of soluble nickel in cellulosic air filter samples and in bulk reference samples, using 0.1 M ammonium citrate for extraction (as part of a sequential extraction method), was ruggedized and validated both within a single laboratory and via interlaboratory trials [Zatka et al. 1992]. This ammonium citrate leaching procedure forms the basis of the ISO 15202-2 (Annex B) methodology [ISO 2012a] for soluble nickel compounds. In other research, soluble silver compounds on PTFE filters were subjected to leaching in deionized water [ISO 2012a] within opaque sampling cassettes, with subsequent analysis by ICP-MS [Drake et al. 2006]. The use of opaque samplers was necessary to prevent photoreduction of silver ions in solution, and ICP-MS was required due to the need for lower method detection limits for the soluble silver fraction in real samples. The soluble silver procedure was validated in-house by using silver nitrate spikes on PTFE filters, demonstrating >90% recoveries. Field studies were also carried out in silver refineries by using a multiport sampler, where it was found



that the soluble silver fraction was less than 2% of the mass of total silver in collected air samples [Drake et al. 2006]. In further work, the use of deionized water for leaching of soluble hexavalent chromium compounds was evaluated [Ashley et al. 2009] as part of a study to validate a standardized sequential extraction procedure for Cr[VI] preceding ion chromatographic analysis [ASTM 2013]. Laboratory experiments on soluble Cr[VI] compounds spiked onto PVC filters resulted in quantitative recoveries, yet interference from Fe[II] (if present in samples) was unavoidable. Water leaching of paint pigment samples and welding fume samples was also evaluated as part of the investigation. It was found that soluble Cr[VI] compounds were prevalent in welding fumes, but their contents were variable in the different paint pigments that were tested [Ashley et al. 2009].

7 Summary

The exposure standards for some metals vary up to a factor of 500 to take into account the increased solubility and bioavailability of some compounds. Even compounds generally considered by chemists as being “insoluble” may have sufficient solubility in body fluids to be of biological importance. Exposure standards for soluble metals such as ACGIH TLVs and other OELs are not specific with regard to extraction fluid, fluid temperature, agitation and other factors affecting solubility. Since these factors significantly affect solubility, some standardization or adoption of an operational definition is necessary if there is to be reproducibility among laboratories conducting soluble metal analyses. In some countries (e.g., nations in the European Union), the national requirements provide this specificity. In other instances, including exposure monitoring standards in the United States, formal national guidelines are not available.

Therefore, adherence to international extraction guidelines or methods such as those described in ISO standards is necessary to produce measurements that are reproducible with other laboratories, and have utility to the laboratory client when exposure standards or national guidelines are vague. ISO 15202 has the advantage over other guidelines and standards in that it has had input from more than 13 participating countries (Table 2). Thus the use of ISO 15202 is encouraged until either exposure standards or national guidelines provide better specificity.

Laboratories cannot recover soluble metal data if inappropriate sample media are used. Sample stability is a problem that must be addressed when sampling for silver (Ag), chromium (Cr) and other soluble metal compounds. Although the ISO procedure has not been validated for all soluble metal species, the standard recommends that method validation be carried out using representative soluble metal compounds for target elements. ISO 15202 provides guidance on sample media selection for soluble metals that can be a useful guide for industrial hygienists and other laboratory clients.



Disclaimer

Mention of any company or product does not constitute endorsement by NIOSH. In addition, citations to websites external to NIOSH do not constitute NIOSH endorsement of the sponsoring organizations or their programs or products. Furthermore, NIOSH is not responsible for the content of these websites. All web addresses referenced in this document were accessible as of the publication date.

8 References

ACGIH [1987]. American Conference of Governmental Industrial Hygienists (ACGIH) Committee Activities and Reports – TLVs for Chemical Substances. *Appl Ind Hyg* 2:R4-R5.

ACGIH [2001]. Documentation of the Threshold Limit Values and Biological Exposure Indices, 7th ed. Cincinnati, OH, USA: American Conference of Governmental Industrial Hygienists (ACGIH).

ACGIH [2015]. Threshold Limit Values for Chemical Substances and Physical Agents and Biological Exposure Indices. Cincinnati, OH, USA: American Conference of Governmental Industrial Hygienists (ACGIH).

Ashley K [1994]. Electroanalytical Applications in Occupational and Environmental Health. *Electroanalysis* 6:805-820.

Ashley K [2001]. International Standard Procedure for the Extraction of Metal Compounds Having Soluble Threshold Limit Values. *Appl Occup Environ Hyg* 16:850- 853.

Ashley K [2015]. Harmonization of NIOSH Sampling and Analytical Methods with Related International Voluntary Consensus Standards. *J Occup Environ Hyg* 12:D107-D115.

Ashley K, Applegate GT, Marcy AD, Drake PL, Pierce PA, Carabin N, Demange M [2009]. Evaluation of Sequential Extraction Procedures for Soluble and Insoluble Hexavalent Chromium Compounds in Workplace Air Samples. *J Environ Monit* 11:318-325.

ASTM [2013]. ASTM D6832, Standard Test Method for the Determination of Hexavalent Chromium in Workplace Air by Ion Chromatography and Spectrophotometric Measurement Using 1,5-Diphenylcarbazide. West Conshohocken, PA, USA: ASTM International; [www.astm.org]. Date accessed: April 6, 2016.



ASTM [2014]. ASTM D5517, Standard Test Method for Determining Extractability of Metals from Art Materials. West Conshohocken, PA, USA: ASTM International.

Beliles RP [1994]. The Metals. In: Patty's Industrial Hygiene and Toxicology, 4th ed., Vol. 2c. New York, NY, USA: Wiley, pp. 1879-2317.

BIA [1989]. Kennzahl 6015, Methodik zur Bestimmung "löslicher Metallverbindungen." In: BIA – Arbeitsmappe Messung von Gefahrstoffen, Vol. 15 (Lfg. IX/95). Sankt Augustin, Germany: Berufsgenossenschaftliches Institut für Arbeitssicherheit (BIA).

CEN [2009]. EN 13890, Workplace Atmospheres - Procedures for Measuring Metals and Metalloids in Airborne Particles – Requirements and Test Methods. Brussels, Belgium: Comité Européen de Normalisation (CEN).

CEN [2013]. EN 71-3, Safety of Toys. Brussels, Belgium: Comité Européen de Normalisation (CEN).

CRC [2015]. Handbook of Chemistry and Physics, 96th ed.; Lide, D. R., ed. CRC Press, Boca Raton, FL, USA.

Drake PL, Marcy AD, Ashley K [2006]. Evaluation of a Standardized Method for Determining Soluble Silver in Workplace Air Samples. *J Environ Monit* 8:134-139.

Draper WM, Ashley K, Glowacki CR, Michael PR [1999]. Industrial Hygiene Chemistry—Keeping Pace with Rapid Change in the Workplace. *Anal Chem* 71:33R-60R.

Fairfax R, Blotzer M [1994]. TLVs – Soluble and Insoluble Metal Compounds. *Appl Occup Environ Hyg* 9:683-686.

Hahn J-U [2000]. Aufarbeitungsverfahren zur analytischen Bestimmung "löslicher" Metallverbindungen – Ein pragmatischer Vorschlag (Preparation Method to Analyze "Soluble" Metal Compounds – A Pragmatic Suggestion). *Gefahrstoffe Reinh Luft* 60:241-243.

HSE [1998]. MDHS Method 42/2, Nickel and Inorganic Compounds of Nickel; and Method 46/2, Platinum Metal and Soluble Platinum Compounds. In: *Methods for the Determination of Hazardous Substances*. London, United Kingdom: Health and Safety Executive (HSE).



IFA [2014]. GESTIS – Database on Hazardous Substances – International Limit Values for Chemical Agents. Sankt Augustin, Germany: Institut für Arbeitsschutz der Deutschen Gesetzlichen Unfallversicherung (IFA); [<https://www.dguv.de/ifa/index-2.jsp>]. Date accessed: April 6, 2016.

INRS [2014]. Fiche 003, Métaux – Métalloïdes. In: *Métrie des Polluants, Evaluation de l'Exposition Professionnelle, Méthodes de Prélèvement et d'Analyse de l'Air*. Paris, France: Institut National de Recherche et de Sécurité (INRS); [www.inrs.fr]. Date accessed: April 6, 2016.

ISO [2011]. ISO 3856, Paints and Varnishes – Determination of “Soluble” Metal Content (7 Parts). Geneva, Switzerland: International Organization for Standardization (ISO); [www.iso.org]. Date accessed: April 6, 2016.

ISO [2012a]. 15202-2, Workplace Air - Determination of Metals and Metalloids in Airborne Particulate Matter by Inductively Coupled Plasma Atomic Emission Spectrometry; Part 2, Sample Preparation – Annex B: Sample Dissolution Method for Soluble Metal and Metalloid Compounds. Geneva, Switzerland: International Organization for Standardization (ISO).

ISO [2012b]. ISO 15202-1, Workplace air – Determination of Metals and Metalloids in Airborne Particulate Matter by Inductively Coupled Plasma Atomic Emission Spectrometry; Part 1, Sampling. Geneva, Switzerland: International Organization for Standardization (ISO).

NIOSH [1994]. Barium, soluble compounds: Method 7056 and Tungsten (soluble and insoluble): Method 7074. In: *NIOSH Manual of Analytical Methods*, 4th ed.; Cassinelli, ME, O'Connor, PF, eds. Cincinnati, OH: U.S. Department of Health and Human Services, Centers for Disease Control and Prevention, National Institute for Occupational Safety and Health DHHS (NIOSH) Publication No. 94-113 [www.cdc.gov/niosh/nmam/].

O'Neil MJ, ed. [2006]. *Merck Index*, 14th ed. Rahway, NJ: Merck & Co.

Wang J, Siegel PD, Lewis DM, Vo E, Wallace WE, Ashley K, Stettler LE [2000]. Spectroscopic Techniques in Industrial Hygiene. In: *Encyclopedia of Analytical Chemistry*; Meyers RA, ed. Chichester, United Kingdom: Wiley, pp. 4783-4824.

Zatka VJ, Warner JS, Meskery D [1992]. Chemical Speciation of Nickel in Airborne Dusts – Analytical Method and Results of an Interlaboratory Test Program. *Environ Sci Technol* 26:138-144.

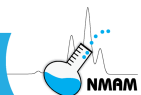

9 Appendix - Solubilities of selected metals and metal compounds [Fairfax and Blotzer 1994]

Aluminum and compounds

Aluminum metal reacts with dilute hydrochloric acid, sulfuric acid, potassium hydroxide, and sodium hydroxide.

The salts of aluminum, including sodium aluminate, aluminum fluoride, aluminum chloride, and cryolite, are all soluble in water.

Arsenic and compounds

Arsenic — Insoluble in hot and cold water; soluble in nitric acid.

Arsenic trioxide and pentoxide — Soluble in cold and hot water, alcohol, alkalis, and hydrochloric acid; arsenic pentoxide is soluble in acids.

Lead arsenate — Insoluble in cold water; soluble in hot water, nitric acid, and caustic alkalis.

Calcium arsenate(s) — Insoluble in water and acids.

Sodium arsenate(s) — Very soluble in water.

Arsenic acid — Soluble in water and alcohol.

Arsenic trisulfide — Practically insoluble in water.

Barium and compounds

Barium metal — Insoluble in water; soluble in alcohol.

Most of the compounds of barium are soluble in (cold or hot) water, for example, barium chloride, barium oxide, barium acetate, and barium cyanide. Barium hydroxide is slightly soluble in water. Barium carbonate is insoluble to slightly soluble in water, and is soluble in acids.

Beryllium and compounds

Beryllium — Slightly soluble in hot water; insoluble in cold water; soluble in dilute alkalis and acids.

Beryllium oxide — Insoluble in water; soluble in some acids and alkalis.

Beryllium hydroxide — Insoluble in water; soluble in acids and alkalis.

Beryllium fluoride — Soluble in cold and hot water, alcohol, and sulfuric acid.

Beryllium sulfate — Soluble in water and concentrated sulfuric acid.

Chromium and compounds

Chromium reacts with dilute hydrochloric acid and sulfuric acid, but not with nitric acid.

Chromium metal — Insoluble in hot and cold water.



Hexavalent chromium compounds, including chromium trioxide, the anhydride of chromic acid, chromates, dichromates, and polychromates, tend to be of low solubility in water and can be subdivided into two subgroups:

- 1.) Water-soluble hexavalent chromium compounds include chromic acid, its anhydride, and the monochromates and dichromates of sodium, potassium, ammonium, lithium, cesium, and rubidium.
- 2.) Water-insoluble hexavalent chromium compounds include zinc chromate, lead chromate, barium chromate, and sintered chromium trioxide. NOTE: Depending on the reference [CRC 2015, O'Neil 2006] both calcium chromate and strontium chromate are listed as soluble and insoluble in water.

Iron and compounds

Iron, ferrous oxide, ferric oxide, and iron oxide — Insoluble in hot and cold water.

Ferric chloride, ferric nitrate, ferric sulfate, ferrous sulfate and ferrous chloride — Soluble in hot and cold water.

Ferric chloride — Soluble in ethanol, methanol, and ether.

Ferric nitrate and ferrous chloride — Soluble in ethanol and acetone.

Ferric sulfate — Sparingly soluble in ethanol; insoluble in acetone.

Ferrous sulfate — Insoluble in ethanol.

Molybdenum and compounds

Molybdenum — Insoluble in hot or cold water; soluble in nitric, sulfuric, and hydrochloric acids.

Molybdc oxide — Sparingly soluble in water; soluble in acids and alkalis.

Molybdenum disulfide — Insoluble in hot or cold water and dilute acids; soluble in hot sulfuric acid, aqua regia, and nitric acid.

Ammonium molybdate — Soluble in hot or cold water, acids, and alkalis.

Calcium molybdate — Insoluble in cold water; soluble in hot water.

Lead molybdate — Insoluble in water and alcohol; soluble in acid and potassium hydroxide.

Sodium molybdate — Soluble in hot and cold water.

Nickel and compounds

Nickel — Insoluble in hot and cold water; soluble in nitric, sulfuric, and hydrochloric acids.

Nickel oxide — Insoluble in hot and cold water; soluble in ammonium hydroxide and acids.

Nickel acetate — Soluble in cold water; insoluble in alcohol [CRC 2015]; soluble in alcohol [O'Neil 2006].

Nickel carbonate — Soluble in cold water; insoluble in hot water.

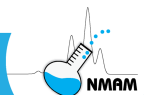

Nickel hydrates — Some forms soluble, others insoluble (in water).

Nickel sulfate — Soluble in hot and cold water.

Platinum and compounds

Platinum — Insoluble in hot or cold water and single mineral acids; soluble in aqua regia; attacked by halogens, alkali cyanides, and caustic alkalies.

Platinum forms are series of complex chloroplatinate salts that are water soluble.

Rhodium and compounds

Rhodium — Insoluble in hot or cold water; soluble in hot sulfuric acid plus hydrochloric acid; slightly soluble in acids and aqua regia.

Water-soluble rhodium compounds include rhodium trichloride, sodium chlororhodite, and rhodium carbonyl acetylacetonate.

Silver and compounds

Silver — Insoluble in water and inert to most acids; reacts readily in dilute nitric acid or hot concentrated sulfuric acid; soluble in fused alkali hydroxides in the presence of air.

Silver oxide — Soluble in hot and cold water, acids, and alkalies.

Silver acetate — Soluble in hot or cold water and nitric acid.

Silver bromide — Insoluble in hot or cold water and nitric acid.

Silver chloride — Soluble in hot water; slightly soluble in cold water and ammonium hydroxide.

Silver cyanide — Soluble in cold water, nitric acid, and ammonium hydroxide.

Silver nitrate — Soluble in hot and cold water.

Thallium and compounds

Thallium — Insoluble in hot and cold water; soluble in nitric, sulfuric, and hydrochloric acids.

Thallos oxide — Soluble in water, acids, and alcohols.

Thallic oxide — Insoluble in hot or cold water; soluble in acids.

Thallos acetate and thallic chloride — Soluble in cold water and alcohol.

Thallos bromide and chloride — Slightly soluble in water.

Thallos sulfate — Soluble in hot or cold water.

Thallos sulfide — Soluble in cold water.

Tungsten and compounds

Tungsten — Insoluble in hot or cold water, hydrofluoric acid, and potassium hydroxide; soluble in mixtures of hydrofluoric and nitric acid; slightly soluble in sulfuric acid.

Tungsten trioxide — Insoluble in hot or cold water and acids; soluble in hot alkalies and hydrofluoric acid.



Tungstic acid — Insoluble in cold water and most acids; soluble in hot water, alkalies, hydrofluoric acid, and ammonia.

Sodium tungstate — Soluble in hot and cold water; slightly soluble in ammonia; insoluble in acids and alcohol.

Tungsten carbide — Insoluble in water; soluble in mixtures of hydrofluoric and nitric acid, and in aqua regia.

Tungsten diboride — Insoluble in hot or cold water; soluble in aqua regia.

Tungsten hexachloride — Soluble in hot water.

Tungsten oxytetrachloride — Soluble in hot or cold water.

Tungsten hexafluoride — Soluble in hot or cold water and alkalies.

Tungsten disulfide — Insoluble in cold water and in alcohol; soluble in mixtures of hydrofluoric and nitric acid.

Phosphotungstic acid — Soluble in cold water, alcohol, and ether.

Ammonium paratungstate — Soluble in water; insoluble in alcohol.

Uranium and compounds

Uranium — Insoluble in hot or cold water, alcohol, and alkali.

Uranium dioxide — Insoluble in hot or cold water; soluble in nitric acid and concentrated sulfuric acid.

Triuranium octoxide — Insoluble in hot or cold water; soluble in nitric acid and sulfuric acid.

Uranium tetrafluoride — Insoluble in cold water, dilute acids, and alkalies; soluble in concentrated acids and alkalies.



NIOSH Manual of Analytical Methods (NMAM), 5th Edition

Monitoring Diesel Exhaust in the Workplace

by **M. Eileen Birch, Ph.D., NIOSH**

| | | |
|----------|--|--------------|
| 1 | Introduction | DL-2 |
| 2 | Analytical method | DL-6 |
| 3 | Interlaboratory comparisons | DL-23 |
| 4 | Occupational exposure criteria (U.S.) | DL-27 |
| 5 | Summary | DL-28 |
| 6 | References | DL-30 |



**Centers for Disease Control
and Prevention**
National Institute for Occupational
Safety and Health



1 Introduction

a. Health effects

Over a million U.S. workers (e.g., trucking, mining, railroad, construction, agriculture) are occupationally exposed to diesel exhaust [NIOSH 1988]. The widespread use of diesel-powered equipment is a recognized health concern. Exposure to diesel exhaust is associated with an increased risk of lung cancer [Attfield et al. 2012; Garshick et al. 2004; HEI 1995; IARC 2012; Silverman et al. 2012]. Diesel exhaust is pervasive, and environmental exposure is a public health concern; but workplace exposures pose higher risk because they are generally much higher than those encountered by the general population.

In 1988, the National Institute for Occupational Safety and Health (NIOSH) reported diesel exhaust as a potential occupational carcinogen and recommended that employers reduce workers' exposures [NIOSH 1998]. This recommendation was based on five independent animal studies, in which rats exposed to unfiltered exhaust showed an increased incidence of benign and malignant lung tumors [IARC 1989]. Other organizations, including the International Agency for Research on Cancer (IARC) [IARC 1989], the World Health Organization (WHO) [WHO 1996], the California Environmental Protection Agency [CalEPA 1998], the U.S. Environmental Protection Agency (EPA) [EPA 2000a], and the National Toxicology Program [NTP 2000] reviewed the animal and human evidence, and each classified diesel exhaust as a probable human carcinogen or similar designation. In 2012, based on epidemiological studies, IARC [IARC, WHO 2012] reclassified diesel exhaust as carcinogenic to humans (Group 1). In particular, a major study of U.S. miners, conducted by NIOSH and the National Cancer Institute (NCI), found increased risk of death from lung cancer in exposed workers [Attfield et al. 2012; Silverman et al. 2012].

Noncancer health effects also are associated with diesel exhaust exposure, including immunologic, respiratory, and cardiovascular effects. Diesel exhaust particles can act as nonspecific airway irritants at relatively high exposures. At lower levels, they can trigger release of mediators (cytokines, chemokines, immunoglobulins, and oxidants) of allergic and inflammatory responses [Pandya et al. 2002]. Diesel particles may promote expression of the immunologic response phenotype (Th2) associated with asthma and allergic disease and may have greater immunologic effects in the presence of environmental allergens. Internationally, the prevalence of asthma (and related hospitalizations and mortality) continues to rise in adults and children. Children may be more vulnerable than adults [Edwards et al. 1994; Weiland et al. 1994; Wjst et al. 1993; van Vliet et al. 1997]. Studies indicate children living along major trucking thoroughfares are at increased risk for asthmatic and allergic symptoms. In the United States, the number of individuals with



self-reported asthma increased by 75% from 1980 to 1994 [Mannino et al. 1998]. The immunologic evidence is consistent with results of epidemiologic studies that associate traffic-related air pollution, especially diesel exhaust particles, with an increase in respiratory diseases.

Studies have consistently found positive associations between particulate air pollution and daily mortality [Brown et al. 2000; Dockery et al. 1993; EPA 1999, 2000b; Pope et al. 1995a; Pope et al. 1995b; Pope et al. 2002; Samet 2000; Schwartz 1997; Schwartz et al. 1996]. The traditional U.S. air quality standard for particulate matter is based on particles having diameters $\leq 10 \mu\text{m}$ (PM₁₀) [52 Fed. Reg. 24634 (1987)]. In 1997, EPA proposed a new standard [62 Fed. Reg. 38652 (1997)] (see www.epa.gov) based on particles having diameters $\leq 2.5 \mu\text{m}$ (PM_{2.5}). These smaller particles originate mainly from combustion sources. The new standard was proposed because recent studies had found higher correlation between fine particle pollution and adverse health effects. In an analysis [Schwartz et al. 1996] of data from six U.S. cities, fine particles were consistently associated with increased risk of death from chronic obstructive pulmonary disease, pneumonia, and ischemic heart disease. Positive associations between fine particle pollution and hospital admissions due to respiratory and cardiovascular illness also have been found [Schwartz 1994; Burnett et al. 1995; Schwartz and Morris 1995]. Particles produced by combustion sources were implicated in these findings. In addition to asthma, chronic inhalation of diesel exhaust particles may play a role in these adverse health outcomes. Reviews on the health effects of diesel exhaust have been published [CalEPA 1998; EPA 2000a; HEI 1995, 2002; IARC 1989; IARC (WHO) 2012; NIOSH 1988; NTP 2000; Solomon et al. 1998; WHO 1996].

b. Composition

Diesel engine exhaust is a highly complex and variable mixture of gases, vapors, and fine particles. The amount and composition of the exhaust vary greatly, depending on factors such as fuel and engine type, maintenance schedule, tuning, workload, and exhaust gas treatment. The gaseous constituents have included hydrocarbons and oxides of carbon, sulfur, and nitrogen. Particulate components consisted of liquid droplets and soot particles bearing organic compounds, sulfates, metals, and other trace elements. The organic fraction (droplets and particle adsorbed) was mainly unburned fuel and oil, but thousands of compounds (e.g., aldehydes, polycyclic aromatic hydrocarbons [PAH]) have been found in the organic fraction—some of which are genotoxic [HEI 1995, 2002; IARC 1989; NIOSH 1988; WHO 1996].

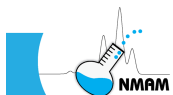

c. Analyte choice: elemental carbon

Because diesel exhaust is a highly complex mixture, a surrogate of exposure must be selected. In the early 1990's, NIOSH researchers considering potential surrogates sought an overall measure of the particulate fraction because animal studies associated lung tumor induction with unfiltered diesel exhaust [IARC 1989; NIOSH 1988], and most (90% in one study) [Schuetzle 1983] of the exhaust's mutagenic potency was associated with the particulate fraction. At the time, gravimetric methods for respirable combustible and submicrometer dusts were being used in mines, but gravimetric methods lack selectivity and are not suitable for low-level (e.g., $<200 \mu\text{g}/\text{m}^3$) measurements. Methods for characterization of the soluble organic fraction of diesel particulate matter (DPM) also were available; others have since been developed. Although measurement of specific organic compounds, particularly genotoxins, may be relevant in characterizing the potential toxicity of diesel exhaust, a single compound or compound class would not reflect exposure to the particulate fraction—even if unique markers are found—because the composition of the exhaust is highly variable.

Carbon is a logical exposure surrogate for traditional diesel engines because DPM is predominantly (typically more than 80%) carbon [Japar et al. 1984; Lies 1989; Pierson et al. 1983]. However, carbon in the organic fraction (i.e., *organic carbon*, or OC) of DPM is not a selective measure because other sources of OC (e.g., cigarette smoke and other combustion aerosols, asphalt fumes) are present in many workplaces. *Elemental carbon* (i.e., carbon in the soot particle core, or EC) is a better surrogate [Birch and Cary 1996a] to monitor because it is a more selective measure of particulate diesel exhaust and still constitutes a sizable fraction (30%–90%) (see [HEI 2002], Part I, Section 1) of the particulate mass. Fine EC particles are derived primarily from the combustion of fossil fuels, and diesel engines have been major sources of these particles. Carbonaceous aerosols such as cigarette and wood smokes contain little, if any, EC [Birch 1998a; Birch and Cary 1996a]. Gasoline engines emit far less EC than diesels, so the contribution of this source is relatively small. Other sources such as coal combustion, incinerators, and tire debris can contribute to the background (environmental) levels of EC, but diesel engines were the primary emitters [Cass and Gray 1995; Sawyer and Johnson 1995]. In occupational settings, where diesel equipment is used in relatively close proximity to workers, the contribution of these remote sources is negligible, especially when EC levels are well above background. Environmental EC concentrations are typically in the $1\text{--}3 \mu\text{g}/\text{m}^3$ range [Birch and Cary 1996a], depending on the local air pollution, while in workplaces with diesel equipment (operating), EC concentrations are generally much higher [e.g., Haney and Fields 1996; NIOSH 1992; NIOSH 1993; NIOSH 1994c; Stanevich et al. 1997; Verma et al. 1999; Whittaker et al. 1999; Zaebst et al. 1991]. Higher environmental background (e.g., $3\text{--}5 \mu\text{g}/\text{m}^3$) has been reported for more polluted U.S. cities (e.g., Los Angeles), but the higher

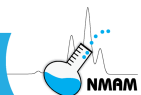

EC levels were attributed to nearby diesel vehicles [Cadle and Mulawa 1990; Gray et al. 1984] (see also [Cass and Gray 1995]). At one monitoring site (Glendora, CA), examination of the data collected at 1-minute intervals revealed that emission plumes from diesel vehicles located 50 meters from the site contributed contamination up to $5 \mu\text{g}/\text{m}^3$ above the background level [Hansen and Novakov 1990].

Carbonaceous dusts such as coal dust (EC content depends on coal rank), carbon blacks, and carbon nanomaterials contain EC, but particles in powders (dispersed as particle agglomerates) and mechanically generated dusts are much larger (generally $>1 \mu\text{m}$ diameter) than combustion-based particles. Therefore, these dusts can be effectively excluded from the diesel sample on the basis of size. Only low levels of EC ($\leq 15 \mu\text{g}/\text{m}^3$) were found in electric-powered (i.e., nondieselized) coal mines when impactors with submicrometer cutpoints were used for air sampling [Birch and Cary 1996b]. Guidance on air sampling is discussed in a following section. In addition to selectivity, potential health effects were considered when an EC surrogate was proposed [55 Fed. Reg. 110 (1990); Birch 1991; Birch and Cary 1996a]. Diesel particles and other types of insoluble fine particles are inhaled deeply into the lungs, where they can induce an inflammatory response. Further, EC particles were shown to increase the long-term retention [Sun et al. 1982; Wolff et al. 1986] of adsorbed genotoxins and other chemical toxins because the particles have a high affinity for them [Niessner and Wilbring 1989]. The adsorbed organic fraction results from rapid cooling of the exhaust mixture, which causes enrichment of some species on the particle surface [Natusch 1978; Thrane et al. 1985; Yamasaki et al. 1982]. Enrichment by this mechanism is associated with compounds of moderate to low volatility [Thrane et al. 1985; Yamasaki 1982]. For example, PAHs having four or more aromatic rings are generally associated with particulate matter [Bjorseth and Becher 1986]; this is important because these higher-ring condensates are expected to be the most carcinogenic or mutagenic [Grimmer et al. 1983; Pott 1985]. In combination with an inflammatory response induced by the particles, genotoxic agents may promote tumorigenesis. Ultrafine particles ($<0.10 \mu\text{m}$) may pose an even greater health risk. Results of toxicological studies on solid particles having aerodynamic diameters in this size range indicate ultrafine particles are especially toxic, even those not having an organic fraction and consisting of materials considered relatively nontoxic (e.g., carbon black, titanium dioxide). In a study of rats [Donaldson et al. 2000], a 10-fold increase in inflammation was seen with exposures to ultrafine particles, relative to the same mass of fine particles. This is significant because, by mass, the majority of diesel particles are in the fine particle range, and most are in the ultrafine range by number [Kittelson et al. 2002]. Given the physical and chemical nature of EC particles emitted by diesel engines, monitoring and controlling exposures to these particles is prudent.

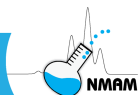

2 Analytical method

a. Background

A monitoring method for DPM was published as Method 5040 in the *NIOSH Manual of Analytical Methods* (NMAM). The method is based on a thermal-optical analysis technique for particulate carbon. Both OC and EC are determined, but EC is a better exposure surrogate. Rationale for selection of an EC surrogate is summarized in the previous section (*Analyte Choice: Elemental Carbon*). Method updates and an NMAM Chapter (Q) have since been published [NIOSH 1994a (1998 supplement); NIOSH 1994b (2003 supplement); NIOSH 2003] to include interlaboratory data (e.g., round robin results) and other diesel-related information obtained since its initial publication (in 1996). This 5th edition chapter is not a review of relevant literature published since the 4th edition. Its purpose is to update references and information on the following topics: classification of diesel exhaust as a human carcinogen, a study of miners exposed to diesel exhaust, results of a subsequent round robin by NIOSH investigators, and application of the Method to carbon nanomaterials. NIOSH 5040 has been used in numerous industrial hygiene surveys on diesel exhaust [e.g., Haney and Fields 1996; NIOSH 1992; NIOSH 1993; NIOSH 1994c; Stanevich et al. 1997; Verma et al. 1999; Whittaker et al. 1999; Zaebst et al. 1991], and it was applied to an epidemiological study (NIOSH/NCI) of miners [Attfield et al. 2012; Silverman et al. 2012]. Details on Method operation and performance are provided in this chapter. Exposure criteria also are discussed.

b. Instrumentation

Of the possible approaches for OC-EC analysis, a thermal-optical technique was investigated because it offered greater selectivity (pyrolysis correction for char) and flexibility (automated analysis, programmable parameter files) than previously used methods. Prior to its proposed use for monitoring occupational exposure to diesel exhaust, thermal-optical analysis (or OC-EC methods in general) had not been applied to occupational monitoring, but the technique had been routinely applied to environmental monitoring of particulate carbon air pollution.

The thermal-optical analyzer (Figure 1) has been described previously [Birch and Cary 1996a; NIOSH 1994a (1998 supplement)]. Design changes (e.g., reflectance monitoring added, software upgraded) have since been made, but the operation principle remains unchanged. OC-EC quantification is accomplished through temperature and atmosphere control. In addition, the analyzer is equipped with an optical feature that corrects for char formed through sample pyrolysis (thermal breakdown in inert atmosphere). Some samples contain components (e.g., cigarette and wood smokes) that carbonize (convert to char carbon) when the sample is heated in helium during the first part of the analysis. Like the

EC typical in fine particle pollution, char strongly absorbs light, particularly in the red/infrared region, resulting in a decrease in the filter transmittance/reflectance. Both volatile products and char are formed during the decomposition process, which may begin near 300 °C and continue until the maximum temperature (860-880 °C) is reached. Optical correction for char is made through use of a pulsed diode laser and photodetector that continuously monitor the filter transmittance/reflectance.

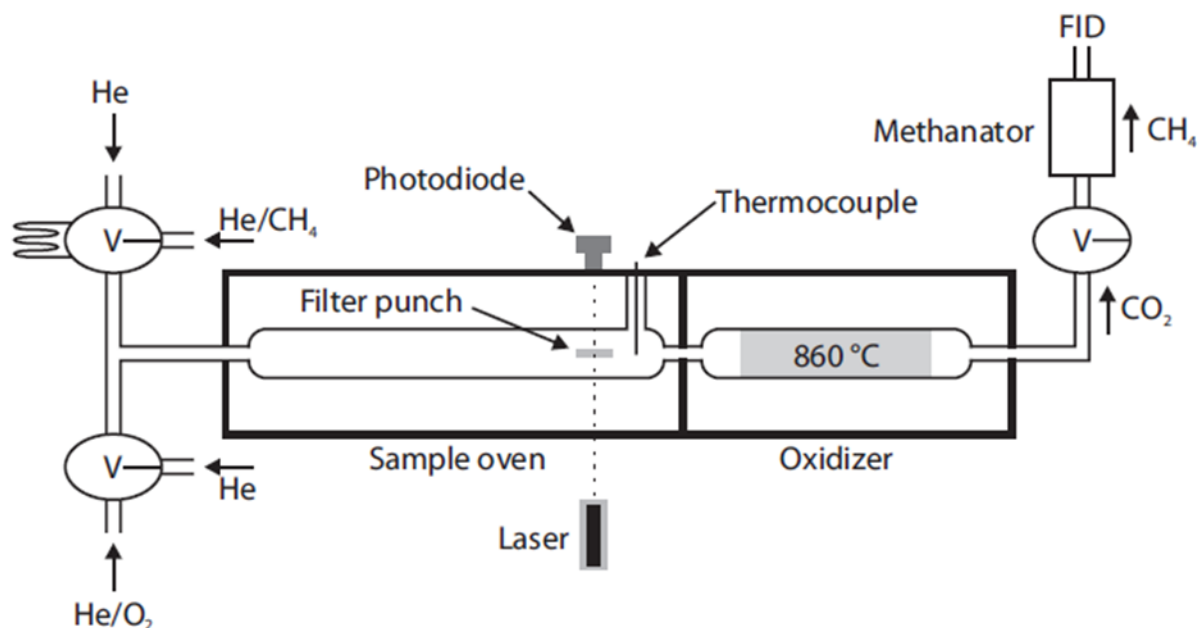

Figure 1. Schematic of thermal-optical transmittance instrument (V = valve) for determining OC and EC in carbonaceous aerosols.

In the thermal-optical analysis, a filter portion (punch) of known area (typically 1.5 cm²) is placed in the sample oven, and the oven is tightly sealed. Quartz-fiber filters are required because temperatures in excess of 850 °C are employed. The analysis proceeds in inert and oxidizing atmospheres. In both, the evolved carbon is catalytically oxidized to carbon dioxide (CO₂). The CO₂ is then reduced to methane (CH₄), and CH₄ is quantified with a flame ionization detector (FID).

OC (and carbonate, if present) is first removed in helium, as the temperature is increased to a preset maximum (usually 850 °C or higher). If charring occurs, the filter transmittance decreases as the temperature is stepped to the maximum. After OC is removed, an oxygen-helium mix is introduced to effect combustion of the remaining carbon. As oxygen enters the oven, light-absorbing carbon is oxidized and a concurrent increase in filter transmittance/reflectance occurs. The *split* (vertical line prior to EC peak in Figure 2) between the OC and EC is assigned when the initial (baseline) value of the filter transmittance is reached. All carbon removed before the OC-EC split is considered

organic, and that removed after the split is considered elemental. If no char is formed, the split is assigned prior to removal of light-absorbing carbon. If the sample chars, the split is not assigned until enough light-absorbing carbon is removed to increase the transmittance/reflectance to its initial value. In general, char is more readily oxidized than diesel-particle EC. The delay (i.e., the transit time from sample to FID) between the laser and FID signals is considered in the split assignment. Ordinarily, the split is assigned in the oxidative mode of the analysis.

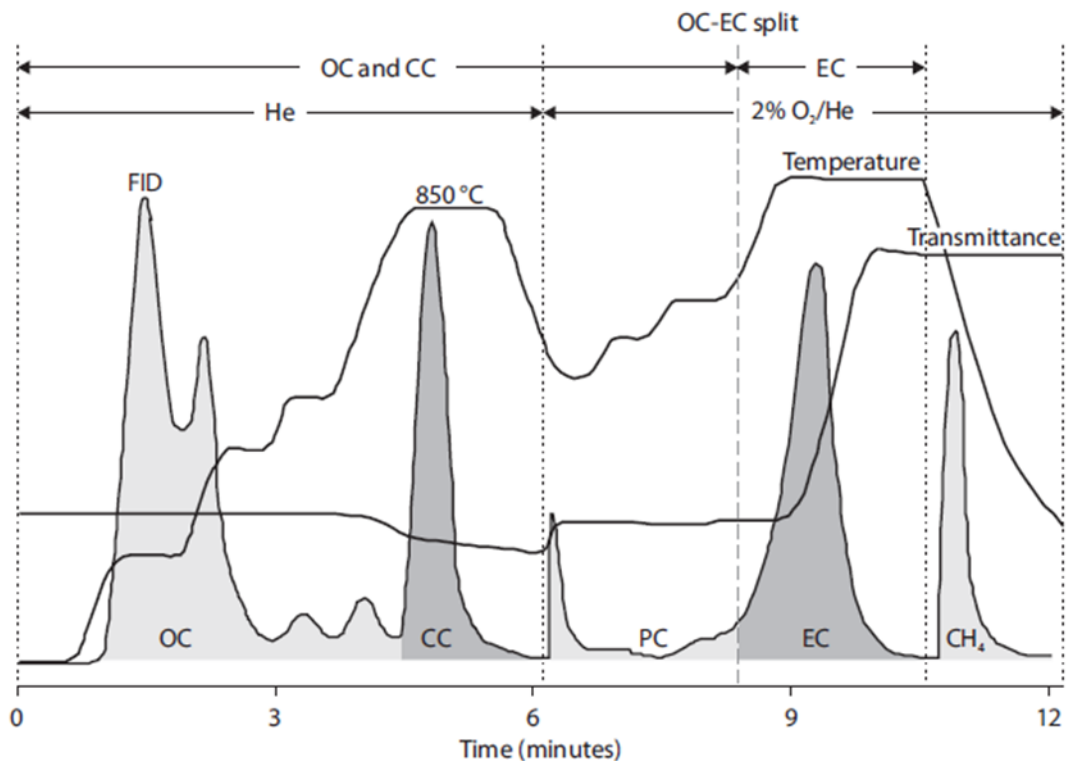

Figure 2. Thermogram for filter sample containing organic carbon (OC), carbonate (CC), and elemental carbon (EC). PC is pyrolytically generated carbon or “char.” Final peak is methane calibration peak. Carbon sources: pulverized beet pulp, rock dust (carbonate), and DPM.

EC and OC results are reported in micrograms per square centimeter ($\mu\text{g}/\text{cm}^2$) of the sample deposit. The total OC and EC on the filter are calculated by multiplying the reported values by the deposit area. In this approach, a homogeneous deposit is assumed. For triplicate analyses, the precision (relative standard deviation) is normally under 5%, and it is typically 2% or better [NIOSH 1994b (2003 supplement)]. The total carbon (TC) in the sample is the sum of OC and EC. If carbonate is present, the carbon in it is



quantified as OC, unless a carbonate-subtracted value is requested. Additional details about carbonates are given in a following section.

c. Accuracy

Reference materials are not available for determining the accuracy of OC-EC measurements on filter samples of complex carbonaceous aerosols. For this reason, only the accuracy of the method in the determination of TC could be examined. No discernable differences in the responses of five different organic compounds were found. Linear regression of the data (43 analyses total) for all five compounds gave a slope and correlation coefficient (r) near unity [slope = 0.99 (± 0.01), $r^2 = 0.999$, $n = 43$]. In addition to the OC standards, eight different carbonaceous materials were analyzed. Three different methods (including the thermal-optical method) were used, and laboratories reported the TC contents of the samples. The samples analyzed included DPM and other types of carbonaceous matter (coals, urban dust, humic acid). Thermal-optical results agreed well with those reported by the two other laboratories. The variability in TC results for the three laboratories ranged from about 1%–7%. These findings [Birch and Cary 1996a; NIOSH 1994a (1998 supplement)] indicate that TC is accurately quantified, irrespective of sample type.

d. Limit of detection

To estimate the method's limit of detection (LOD), a set of low-level calibration standards (ethylenediaminetetraacetic acid [EDTA]) was analyzed [Birch and Cary 1996a; NIOSH 1994a (1998 supplement)]. The standards covered a loading range from 0.23 to 2.82 $\mu\text{g C}$ (or from 0.15 to 1.83 $\mu\text{g C}$ per cm^2 of filter). Results of linear regression of the low-level calibration data were then used to calculate a LOD as $3\sigma_y/m$, where σ_y is the standard error of the regression and m is the slope of the regression line. The LOD estimated through the linear regression results was 0.24 $\mu\text{g C}$, or 0.15 $\mu\text{g}/\text{cm}^2$. This value showed good agreement with the LOD estimated as $3\sigma_{\text{blank}}$ (three times the standard deviation for blanks), which gave a value of about 0.3 $\mu\text{g C}$. The mean ($n = 40$) instrumental blank was $0.03 \pm 0.1 \mu\text{g C}$. With a 960-L air sample collected on a 37-mm filter and use of a 1.5 cm^2 sample portion, this LOD translates to an air concentration of about 2 $\mu\text{g}/\text{m}^3$. As with all sampling and analytical methods, the LOD is a varying number that depends on the instrument, sampling parameters, and means by which the LOD is calculated.

NIOSH Method 5040 was developed for monitoring workplace exposure to DPM, especially in mines, where EC concentrations are relatively high (e.g., hundreds of $\mu\text{g}/\text{m}^3$). However, the thermal-optical technique on which 5040 is based has application to other types of carbonaceous aerosols. Thermal-optical analysis also has been applied to studies of U.S. workers exposed to carbon nanotubes and nanofibers (CNT and CNF) [Birch et al.

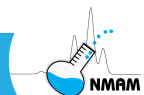

2011; Dahm et al. 2012; Dahm et al. 2015; NIOSH 2013]. For these studies, a lower LOD was needed because workplace concentrations of CNT/CNF are generally low. As recommended in Method 5040, a smaller (25-mm) filter and a higher flow rate were used to obtain a lower LOD (about 1 $\mu\text{g EC}/\text{m}^3$ or lower). Manual assignment of the OC-EC split also was made. Application of Method 5040 to carbon nanomaterials is discussed below (see Carbon Nanomaterials).

e. Air sampling

In the initial evaluation of the thermal-optical method, a set of laboratory-generated air samples was analyzed. A dilution tunnel equipped with a dynamometer was used for generation of diesel particulate samples. Four EC concentrations, ranging from 23 to 240 $\mu\text{g}/\text{m}^3$ (EC loadings from 2.7 to 27 $\mu\text{g}/\text{cm}^2$), were generated. The analytical results [NIOSH 1994b (1998 supplement)] indicated that the method met the NIOSH accuracy criterion [Kennedy et al. 1995]. The variance was roughly proportional to the mean concentration; therefore, the relative standard deviation (RSD) decreased with increasing concentration. The accuracy was calculated accordingly. The accuracy was $\pm 16.7\%$ at the lowest loading (2.7 $\mu\text{g}/\text{cm}^2$), with an overall precision (RSD) of 8.5%. On the basis of a method evaluation, the NIOSH accuracy criterion requires a confidence limit on the accuracy less than 25% at the 95% confidence level. Restated, the criterion dictates that greater than 95% of the measurements fall within $\pm 25\%$ of the true value at 95% confidence in the method's validation experiments. The method was considered unbiased (i.e., considered the reference method), and the overall precision reflected method accuracy. In this initial test, the sample generation and collection system was the main source of variability, not the analysis.

When only combustion-source EC is present, different samplers can be expected to give comparable EC results because particles from combustion sources are generally less than 1 μm (diameter). As such, the particles are evenly deposited on the filter and collected with the same efficiency (near 100%). To confirm this assumption, seven different sampler types (open-faced 25-mm and 37-mm cassettes; 298 personal cascade impactor [7 stages, 0.9- μm cutpoint]; 4 prototype impactors) were used to collect diesel aerosol at the loading dock of an express mail facility. The RSD for the mean EC concentration was 5.6% [Birch and Cary 1996a]. Based on the 95% confidence limit (19%; 13 degrees of freedom, $n = 14$) on the accuracy, results of this experiment also indicated that the NIOSH accuracy criterion [Kennedy et al. 1995] was fulfilled. The amount of EC collected (240 μg per sample) would have been equivalent to sampling an air concentration of 250 $\mu\text{g}/\text{m}^3$ for 8 h at 2 L/min. Variability in the OC results was higher (RSD = 12.3%), which is to be expected when different samplers are used to collect aerosols that contain semivolatile (and volatile) components because these can have a filter face velocity dependence.



Similar performance was obtained from collected samples in an underground molybdenum mine. Five different sampler types were used (closed-face 25-mm and 37-mm cassettes; 298 cascade impactor [7 stages, 0.9- μm cutpoint]; cyclone with filter; in-house impactor). The RSD for the EC results (mean EC = 297 $\mu\text{g}/\text{m}^3$) was 7%. The EC deposits obtained with all five sampler types were homogeneous, even when the ore deposit was visually heavier in the center of the filter (e.g., with the closed-face 37-mm cassette). Although the dust loading was higher in the center of the filter, portions taken from the center gave equivalent EC results, indicating the ore contained no EC component. The TC results for the center portions were only slightly higher, so this particular ore was mostly inorganic. EC concentrations found with three different sampler types (nylon cyclone, open-faced cassette, and impactor with submicrometer cut) also were comparable in a study of railroad workers [Verma et al. 1999].

If high levels of other dusts are present, a size classifier (e.g., impactor and/or cyclone) should be used to prevent filter overloading, particularly if the dust is carbonaceous. In the latter case, a size classifier provides a more selective measure of the diesel-source OC. It also provides a better measure of the diesel-source EC if the dust contains an EC component, which is less common. A finely ground sample of the bulk material can be analyzed to determine whether a specific dust poses potential interference [Birch and Cary 1996a]. Depending on the dust concentration, size distribution, and target analyte, an impactor may be required.

For mines, the Mine Safety and Health Administration (MSHA) recommends a specialized impactor to minimize collection of carbonates and other carbonaceous dusts [66 Fed. Reg. 5706 (2001)]. An impactor can greatly improve the selectivity of the TC measurement in some cases, but it may exclude a small amount of the DPM. Then, too, some OC interferences cannot be excluded on the basis of size (e.g., condensation aerosols, fumes, wood and cigarette smokes). If present in the sampling environment, these materials can positively bias the OC (TC) results to some degree, depending on their relative concentrations and the sampling location. Although 37-mm or 25-mm cassettes are often suitable for general industry, the required sampler depends on the sampling environment.

f. Carbonates

The presence of carbonate is indicated by a narrow peak during the fourth temperature step in helium (Figure 2). Its presence is verified by exposing a second portion of the filter to hydrogen chloride (HCl) vapor prior to analysis. When the acidified portion is analyzed, a diminished (or absent) peak during the fourth temperature step is indicative of carbonate in the original sample. (Note: Acid treatment may sometimes alter the

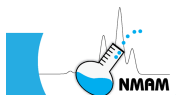

appearance of the EC profile in the thermogram [output signal of thermal-optical instrument], but the EC result itself should not be affected significantly.)

A desiccator containing concentrated HCl (added to the desiccator or a petri dish placed at the bottom of it) can be used to acidify the sample portions. The desiccator, or alternative vessel, should be used in a well-ventilated hood. The filter portions are placed on the desiccator tray, and the tray is placed in the desiccator. A wetted pH indicator stick can be used to check acidity. A wetted indicator stick inserted between the desiccator lid and base should give a pH near 2. Portions should be exposed to the acid vapor for about 1 hour (large particles may require more time). After acidification, the tray is placed on a clean, inert surface inside the hood. The residual acid on the portions should be allowed to volatilize in the hood for at least an hour prior to analysis.

Environmental samples typically contain little (if any) carbonate, but levels in some occupational samples can be quite high. For example, respirable dust samples collected in limestone and trona mines can contain high levels of calcium carbonate and sodium sesquicarbonate, respectively. In such cases, acidified samples give a better measure of the diesel-source OC (TC). If the carbonate loading is relatively high (e.g., carbonate carbon >10% of the TC), the difference between the TC results (before and after acidification) gives an estimate of carbonate carbon (CC). Estimation of CC by difference assumes the carbonate is evenly deposited on the filter, which may not always be the case. It also assumes that OC loss through acidification is negligible. The latter assumption is generally true for workplace samples, but depends on sample composition and loading.

Alternatively, a carbonate-subtracted OC (TC) result can be obtained through separate integration of the carbonate peak. This applies only to carbonates (e.g., calcium carbonate) that can be removed as a single peak during the fourth temperature step in helium. The carbonate of interest should be analyzed to ensure this is the case. A minor adjustment (lower) to the third temperature step may be necessary to prevent partial loss during this step. Sodium sesquicarbonate (trona) is removed over multiple temperature steps. Samples containing trona should be acidified if a carbonate-subtracted result is desired. (*Note: At elevated temperature, trona and other compounds containing sodium can etch the quartz oven wall and sample holder. An etched surface can reduce laser throughput. Avoid frequent analysis of high-sodium materials and direct contact of these materials with the oven wall and sample holder.*)

The presence of a small “peak” during the fourth temperature step is not necessarily due to carbonate. Other carbonaceous matter (e.g., char) is sometimes removed during the fourth step. Unlike carbonates, which produce a relatively sharp peak, other materials typically evolve as a small, broad peak. If determination of relatively low (e.g., CC <10% of TC)

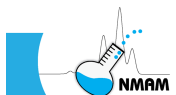

amounts of CC is desired, a second portion of the sample should be acidified and analyzed to verify the presence of carbonate and reveal any underlying baseline features contributed by other materials. A more accurate estimate of CC can then be obtained by integrating the first (nonacidified) sample over the missing peak area (i.e., area removed through acidification).

g. Carbon nanomaterials

NIOSH Method 5040 was developed for monitoring workplace exposure DPM, as EC, but the thermal-optical analysis technique on which it is based has application to other types of carbonaceous aerosols and materials. Method 5040 has been applied to field studies on carbon nanomaterials, wherein EC was used as a measure of exposure to carbon nanotubes and nanofibers (CNT and CNF) [Birch et al. 2011; Dahm et al. 2012; Dahm et al. 2015; Fatkhutdinova et al. 2016; NIOSH 2013]. Because CNT/CNF are composed of EC, EC is a quantitative measure of airborne CNT/CNF [Birch et al. 2011; NIOSH 2013]. In 2013, NIOSH set a recommended exposure limit (REL) for CNT/CNF: an 8-hr time weighted average (TWA) of 1 $\mu\text{g}/\text{m}^3$ as respirable EC [NIOSH 2013].

For application of NIOSH 5040 to CNT/CNF, a manual OC-EC split is assigned. The larger size (μm versus nanoscale DPM) and agglomerate structure of CNT/CNF particles, combined with low air concentrations (i.e., filter loadings), make the 5040 auto-split unreliable [Dahm et al. 2015; NIOSH 2013]. Adjustments to the thermal program also may be needed depending on the material, size fraction collected, and environmental background [Birch et al. 2011; Dahm et al. 2015; Doudrick et al., 2012; NIOSH 2013]. Analysis of bulk and background samples is recommended [NIOSH 2013]. Determining the thermal profiles of bulk materials produced/processed in a given workplace, and using this information, along with results for background samples, assists manual assignment of the OC-EC split and can provide more accurate CNT/CNF measurement.

Because CNT/CNF oxidize over a range of temperatures, it is important to analyze bulk and background samples [Birch et al. 2011; Dahm et al. 2015; NIOSH 2013]. For example, Mitsui-7 MWCNT (Mitsui & Co., LTD, Tokyo, Japan), used in early NIOSH toxicity studies, is more difficult to oxidize (onset $> 700\text{ }^\circ\text{C}$). A NIOSH (Cincinnati, OH, USA) laboratory normally uses a final temperature (in oxygen-helium) of $920\text{ }^\circ\text{C}$, which is adequate provided that the loading is not too high and the hold time (at final temperature) is long enough. A higher (up to about $940\text{ }^\circ\text{C}$) or lower maximum can be used, and the heating period at maximum temperature can be adjusted according to the type and amount of material analyzed. If the signal returns to baseline, EC in the sample is completely oxidized. If not (i.e., there is signal 'tailing' into the calibration peak), the final temperature can be increased and an extended period can be used. In addition to Mitsui-7



(MWCNT), some graphite products are difficult to oxidize. On the other hand, if a material is completely oxidized at 875 °C, prolonged heating at 920 °C is unnecessary. In some cases (e.g., early EC loss), a lower maximum temperature in the helium also may be appropriate [NIOSH 2003]. These changes are minor adjustments that can be made to optimize the thermal analysis.

In general, most CNT/CNF materials can be oxidized from the filter. However, there may be instances where sample oxidation is incomplete, even with holding at 920 °C (or higher) for an extended period (e.g., high loadings of graphite products or Mitsui-7). For bulks analyses, only small amounts (e.g., about 10 µg or less) of material should be analyzed, to better match the loadings of the field samples, for comparison with the bulk. If residual material (CNT) remains (post analysis), incomplete oxidation is obvious as the signal does not return to baseline and a filter deposit is visible.

Even with the aid of bulks and judicious choice of background samples, it may not be possible to exclude EC background, posing an interference problem at low CNT/CNF loadings. Also, amorphous carbon in the CNT/CNF materials may cause positive bias [NIOSH 2013]. If the oxidation rates of the amorphous carbon and CNT/CNF are sufficiently different, it may be possible to remove the amorphous material to a greater extent, but the oxidation rates may be too similar for speciation.

h. Sampling artifacts: organic aerosol

1.) Face Velocity

Quartz-fiber filters are routinely used to collect airborne particulate matter for carbon determination. Quartz filters have high collection efficiency for particulate carbon, but collection of organic aerosol is artifact prone [Cui et al. 1998; Kirchstetter et al. 2001; McDow and Huntzicker 1990; Turpin et al. 1994; Zang and McMurry 1992].

Particulate carbon (EC and nonvolatile OC) results should not depend on filter face velocity. This is true for EC, but OC (and TC) results can have a face velocity dependence due to sampling artifacts. Namely, adsorption of organic vapor can positively bias the results, while evaporative losses have the opposite effect. Although both processes may occur, studies indicate vapor adsorption is the dominant artifact [Kirchstetter et al. 2001; Turpin et al. 1994]. In one study [Turpin et al. 1994], the OC (TC) results for air samples collected at face velocities of 20, 40, and 80 cm/sec had a face velocity dependence before, but not after, correction for adsorbed vapor. Lack of dependence after correction supports adsorption as the dominant artifact. At the much lower face velocities typical of occupational monitoring (e.g., about 4 cm/sec with a 37-mm filter and 2 L/min flow rate), OC losses induced by pressure drop across the filter are expected to be minor relative to adsorption. OC sampling artifacts were

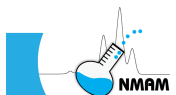

acknowledged when the thermal-optical method was proposed [55 Fed. Reg. 110 (1990); Birch 1991], but this issue was not investigated prior to publication of NIOSH 5040 because an EC surrogate was recommended. In view of the MSHA-proposed air standard for TC (proposed after 5040 publication), and the fact that both OC and EC are determined, the issue was later addressed.

2.) Adsorbed OC

Correction for adsorbed organic vapor through use of traditional blanks (media or field) may not be accurate because the amount of vapor adsorbed by them is variable [Birch et al. 1999a]. More importantly, traditional blanks collect vapor passively, while the samples collect it actively (during sampling). A more representative correction for adsorbed organic vapor can be made through use of two filters in tandem [Kirchstetter et al. 2001; Turpin et al. 1994]. The air sample is collected with a sampler containing a Teflon® or quartz upper filter and a bottom quartz filter. After sampling, the bottom filter is used to correct for adsorbed vapor. The vapor adsorbed on the bottom filter more closely represents that adsorbed on the sample filter (quartz) because both are collected actively. Use of two quartz filters is preferable to Teflon and quartz because the filter used to correct for adsorbed vapor is in the same sampler; however, the second (bottom) quartz filter may underestimate the amount of adsorbed OC relative to a quartz filter under Teflon [Kirchstetter et al. 2001; Turpin et al. 1994]. These results have been attributed to depletion of the vapor concentration by the top quartz filter, which presents a lower concentration to the bottom one. A shorter equilibration time (for partitioning between gas phase and adsorbed state) is expected with Teflon filters because they have less surface area and are more inert than quartz. Thus, less adsorption is expected on Teflon relative to quartz. Because differences in the amount of adsorbed OC have been reported for the two sampling configurations, both were examined.

Six sets of air samples were collected. Two pre-cleaned quartz-fiber filters were loaded into each of eight 37-mm cassettes. In four of these, a Teflon filter was then placed on top. The bottom quartz filters in all eight cassettes, as well as the four directly under the Teflon filters, provided measures of adsorbed OC. Filters in four additional cassettes served as passive field blanks, meaning no air was pulled through them. The second (bottom) quartz filters in the cassettes with the Teflon filters were compared to the bottom quartz filters in those having only a quartz pair. If negligible adsorption occurs on Teflon, the bottom quartz filters in the two different sampling configurations should give equivalent results. To avoid possible variability due to lot-to-lot differences, filters from the same lot were used to collect a given sample set.

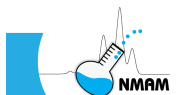

3.) Portable dust chamber

A portable dust chamber [Kogut et al. 1997] designed for sampling in mines was used for sample collection. The chamber allowed simultaneous collection of up to eighteen samples. Twelve cassettes were mounted inside the chamber in a symmetrical fashion. Samples were collected on six different days, five days in a loading dock area and a sixth near an outside smokers' shelter. A diesel truck was operating in the loading dock, over different periods, on three of the days. Personal air pumps were programmed to run at 2 L/min over an 8-hour period. In one case, the pumps were stopped after 23 minutes. The short sampling period provided a low loading of diesel exhaust (a light deposit was visible) and was of interest with respect to the amount of adsorbed carbon collected in the short time frame.

Results for the six sample sets are shown in Table 1 and Figure 3. The QQ2 results correspond to the bottom quartz filters in the four cassettes containing quartz pairs only. The TQQ1 results are for the four filters directly beneath Teflon filters; TQQ2 results are for quartz filters beneath the TQQ1 filters (i.e., top Teflon, middle TQQ1, bottom TQQ2). The mean carbon on the bottom quartz filters ranged from 1.35 to 3.44 $\mu\text{g}/\text{cm}^2$, and the variability (RSD) ranged from about 4% to 12% on a given day. The loading found on the two sets of bottom filters (QQ2 and TQQ2) was not statistically different, so all bottom filters were pooled in the calculation of the mean. The pooled means for the bottom quartz filters (BQ), the means for the quartz under Teflon (TQQ1), and the corresponding OC and EC loadings are plotted in Figure 3. Results for the TQQ1 filters were only slightly higher than those for the bottom quartz filters, even with the 23-minute sampling period (set 4). Thus, using a separate cassette that has a top Teflon filter appears unnecessary. Although differences between the amount of carbon adsorbed on a quartz filter under another quartz and on one beneath a Teflon filter reportedly can be significant [Kirchstetter et al. 2001; Turpin et al. 1994], these studies concerned environmental monitoring at much higher flow rates. The negligible differences reported here most likely relate to the lower flow rates and filter face velocities used.

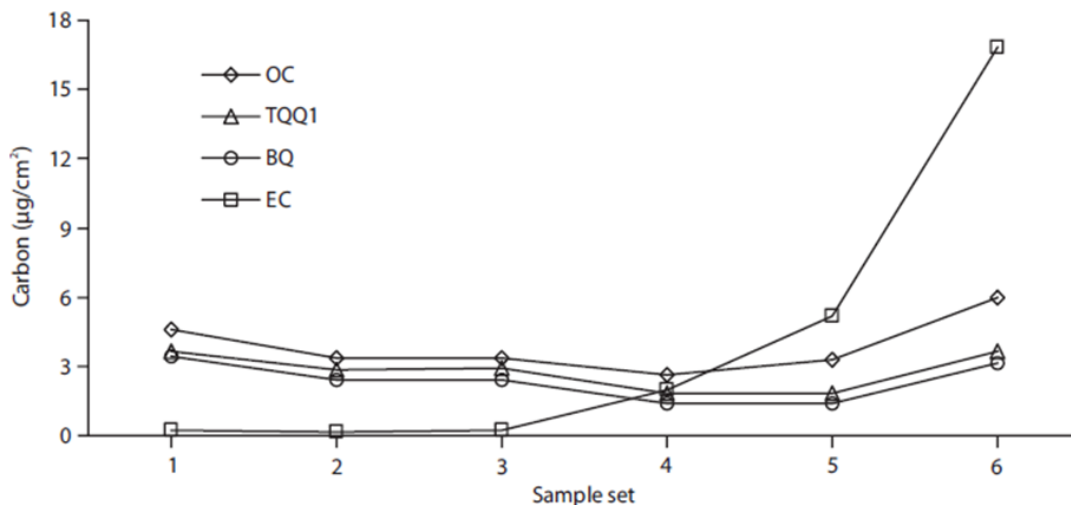
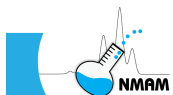

Figure 3. Results for six sets of air samples collected in two outdoor locations. OC and EC results are the means for the top quartz filters (QQ1) of quartz-filter pairs. TQQ1 is the mean carbon (total) result for quartz filters placed directly beneath Teflon. BQ is the mean carbon result for all bottom quartz filters (i.e., QQ2 and TQQ2). See text for additional details.

Table 1. Results summary for total carbon (TC, µg/cm²) from six sets of air samples collected in two outdoor locations (SD = standard deviation; RSD = relative standard deviation). See text for details.

| Set | Location | QQ1 mean | QQ1 SD | QQ1 RSD (%) | TQQ1 mean | TQQ1 SD | TQQ1 RSD (%) | Bottom quartz mean, QQ2 | Bottom quartz mean, TQQ2 | Bottom quartz mean, pooled | Bottom quartz mean, SD | Bottom quartz mean, RSD (%) | Adsorbed fraction (%) |
|-----|----------|----------|--------|-------------|-----------|---------|--------------|-------------------------|--------------------------|----------------------------|------------------------|-----------------------------|-----------------------|
| 1 | shelter | 4.81 | 0.47 | 9.77 | 3.66 | 0.43 | 11.8 | 3.46 | 3.41 | 3.44 | 0.30 | 8.80 | 76 |
| 2 | dock | 3.52 | 0.25 | 7.10 | 2.82 | 0.36 | 12.8 | 2.48 | 2.33 | 2.43 | 0.23 | 9.57 | 80 |
| 3 | dock | 3.61 | 0.05 | 1.39 | 2.89 | 0.04 | 1.38 | 2.41 | 2.42 | 2.41 | 0.18 | 7.45 | 80 |
| 4 | dock | 4.59 | 0.18 | 3.92 | 1.79 | 0.24 | 13.4 | 1.41 | 1.36 | 1.38 | 0.09 | 6.46 | 30 |
| 5 | dock | 8.43 | 0.33 | 3.91 | 1.84 | 0.35 | 19.0 | 1.35 | 1.36 | 1.35 | 0.16 | 12.0 | 22 |
| 6 | dock | 22.8 | 0.35 | 1.54 | 3.62 | 0.18 | 4.97 | 3.10 | 3.18 | 3.14 | 0.13 | 4.09 | 16 |

The mean carbon loading (Table 1) on the sample filters (QQ1) was about 4 µg/cm² on four different days (sample sets 1–4). A diesel truck was operating briefly on one of these days (set 4). On two other days (sets 5 and 6), the truck was running for longer periods, as evidenced by the higher EC loadings (Figure 3). The corresponding TC loadings on these two days were about 8 µg/cm² and 23 µg/cm². Over the loading range, the amount of adsorbed OC had no dependence on the TC loading, and the OC results for the bottom quartz filters (1.35 to 3.44 µg/cm²) were higher than those for the passive field blanks (0.17 to 0.74 µg/cm²). Two of the results (sets 4 and 5) were slightly lower than the others. In one case (set 4), the sampling period (23 minutes) was shorter, but the adsorbed OC results for the bottom filters in both sampling configurations (i.e., QQ2 and TQQ2) were equivalent and comparable to the upper



quartz filters (TQQ1), below the Teflon. This implied that partitioning [Turpin et al. 1994] (between gas and adsorbed states) on the sample filters (QQ1) had reached equilibrium; thus, the lower result was not due to lack of equilibration. In large part, the results for passive blanks provided a likely explanation for the lower value. The mean blank (passive) for this set was $0.17 (\pm 0.10) \mu\text{g}/\text{cm}^2$, which was the lowest value obtained. Passive blank results for the other sets (excluding set 5) ranged from $0.25 (\pm 0.07)$ to $0.74 (\pm 0.14) \mu\text{g}/\text{cm}^2$. It is not known whether the same explanation applied to set 5 because passive blanks for this set were accidentally contaminated (results voided). As in sets 1–3 and 6, set 5 was collected for an 8-hour period, but it was collected during the spring, while the other sets were collected during midsummer. Changed weather conditions may explain the lower value.

Over three days, the adsorbed OC fraction (calculated as the TQQ1 TC mean divided by QQ1 TC mean) constituted about 80% of the TC on the sample filters (QQ1). On three other days (sets 4, 5, and 6), the adsorbed OC fraction was 39%, 22%, and 16% of the total. A backup quartz filter provided a better correction for adsorbed carbon than a traditional blank would have. Traditional blanks (media and field) underestimated the adsorbed OC, causing overestimation of the true particulate OC (TC) concentration. The need for this correction, and the number of backup filters analyzed, depends on the sampling strategy and environment. The lower the OC loading, the greater the influence of adsorbed vapor on the particulate OC measurement. If the EC loading also is low, the same holds true for the TC result. Thus, when carbon loadings are low, correction for adsorbed OC is important for accurate measurement of particulate OC and TC concentrations. However, the correction addresses adsorbed vapor only—not interference of less volatile materials (e.g., components in cigarette and wood smokes, oils) collected primarily on the top filter. Depending on vapor pressure, sampling conditions (temperature, flow rate, sampling period), and filter loading, these materials also collect on the bottom filter to some extent. The bottom filter cannot correct for this interference. If high OC loadings are found on the bottom filter, less volatile OC interferences should be suspected.

i. EC oxidation in helium

In the NIOSH 5040 analysis, oxidation of original EC (as opposed to char) is sometimes seen during the last temperature step in helium, but this is generally not common. If early removal occurs, it is important to ensure that oxygen contamination is not responsible. This check can be performed by analyzing a sucrose standard solution applied to a clean, unused filter punch. Although char loss is sometimes observed with sucrose, the filter transmittance normally does not reach its initial value until after oxygen is introduced. If oxygen contamination can be ruled out, the early EC loss is most likely due to oxidants in



the sample. In our laboratory, EC loss in helium has been observed with samples from a few mines [Birch 1998b]. With these samples, the filter transmittance exceeded its baseline (initial) value during the last temperature step in helium. No sample pyrolysis was apparent, so the increase in transmittance was not caused by char loss. Moreover, analysis of sucrose standards revealed only a minor increase in transmittance in helium, and no increase was seen with samples from other mines. For these reasons, oxygen contamination was ruled out. On average, about 10% of the EC was removed at 870 °C in helium, but the carbon removed was included in the EC result because the OC-EC split was assigned when the initial transmittance was reached (in helium). Reducing the maximum temperature to 750 °C was recommended [NIOSH 1994a, 1994b] for these types of samples (i.e., *no sample charring and early splits in helium*). Early EC loss was not seen at this temperature. A lower (<750 °C) temperature may be required, depending on the sample composition. Our analytical results and precision were not affected by the early splits, but a reduced temperature was recommended in the interest of interlaboratory precision, which might be adversely affected. Interlaboratory testing was not conducted to determine if this is the case, and, if so, whether a lower temperature would improve precision.

j. Reference materials

As mentioned, a suitable reference material for OC and EC is not available. A Certified Value (17.68% g/g) for the TC mass fraction of an urban dust standard (SRM 1649a, formerly SRM 1649) was reported by the National Institute of Standards and Technology (NIST), but only Information (not Certified) Values were provided for the EC content. The EC content (as EC:TC fractions) was determined by a variety of methods. As expected, based on prior studies [Birch 1998a; Chow et al. 2001; Countess 1990; Norris et al. 1999; Schmid et al. 2001], the results were quite variable. The EC:TC fractions found by 13 methods ranged from about 7% to 52%, and the data were distributed in three clusters. Method bias was not evaluated. The reported range is too broad to use this material as an analytical standard. According to the Certificate of Analysis (1649a), the reported values may be useful for comparison with results obtained by similar methods, but this may not be the case for methods with optical corrections because filter samples are not available. Depending on its placement, bulk dust on a filter can present different optical properties, which may increase variability. Sample composition is an important consideration in the production of an analytical reference material. As is true with many standards, no single OC-EC material can be representative of all samples because there are many sources of particulate carbon and many different monitoring sites—both occupational and environmental. Production of an OC-EC reference material is further complicated by the variability between methods (SRM 1649a provides only Information Values for different methods), and the need of a filter-based material for thermal-optical methods.



Because sample components that char pose a potential interference in the determination of EC, and interlaboratory variability is greater when samples contain them, analysis of organic materials that char provides an important quality assurance check. Sucrose serves as both an analytical standard and a check of the method's char correction, but sucrose is a simple carbohydrate (a disaccharide). Air samples can contain complex particulate matter, such as wood and cigarette smokes, plant debris (cellulose), and products of biomass burning. In some cases, biomass may contribute a sizable fraction of the sample carbon. About 38% of the particulate carbon in SRM 1649a (an urban dust) is derived from biomass (see Certificate of Analysis [NIST 2001] and related publication [Currie et al. 2002]). For these reasons, a material more representative of the plant-derived components in air samples was sought.

Various plant-derived materials were examined to determine whether any would be useful as laboratory control samples. A well-characterized, stable material that chars also would be useful for proficiency testing, and it could potentially be used to produce a standard reference material. After a preliminary screening of candidate materials (e.g., agarose, alginic acid, starch, and cellulose), alginic acid was selected for further study. Alginic acid is a polysaccharide derived from sea kelp [Morrison and Boyd 1973], it has adequate solubility in water, and it forms a significant amount of char during the analysis.

To prepare a solution, about 150 mg of alginic acid (Sigma-Aldrich, St. Louis, MO) was added to a test tube containing 10 mL of purified water (ultrafiltered, type I). The tube was shaken vigorously and allowed to sit overnight at room temperature. The following day, the tube was shaken again and then centrifuged to settle the suspended material. The clear supernatant was removed and syringe filtered. Aliquots of the alginic acid solution were applied to clean filter punches. The solution was analyzed over a seven-week period. Results of these analyses are plotted in Figure 4. No evidence of solution degradation was observed. A mean carbon loading of $13.98 \mu\text{g}/\text{cm}^2$ (RSD = 3.06%, $n = 22$) was obtained for 10- μL aliquots of the solution. This translates to a carbon concentration of $2.06 \mu\text{g}/\mu\text{L}$. About half of the carbon in alginic acid remained on the filter as char before oxygen was introduced, but the mean EC result ($0.04 \pm 0.06 \mu\text{g}/\text{cm}^2$) was not statistically different from that for the media blanks (0.06 ± 0.03). Therefore, the pyrolysis correction was accurate.

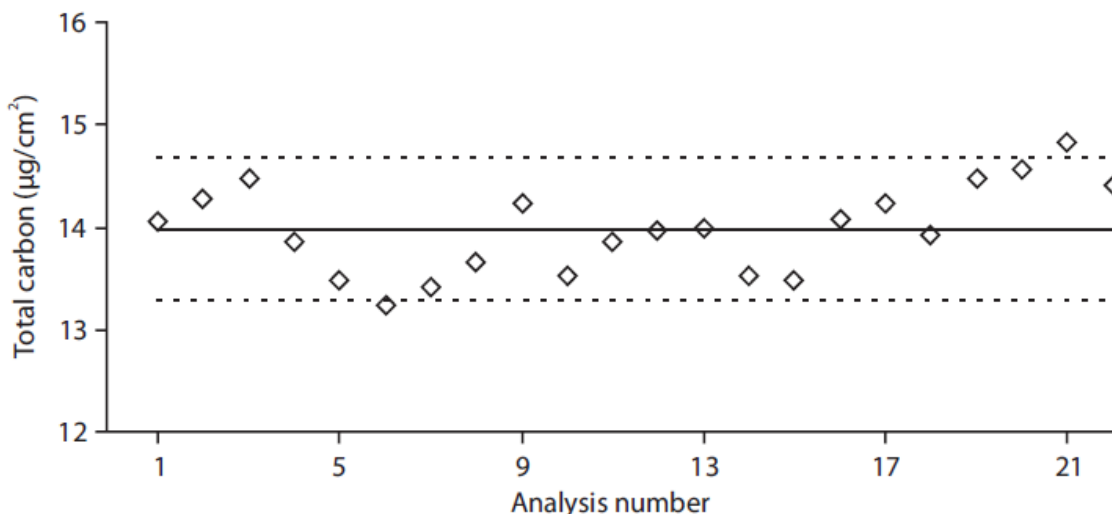

Figure 4. Results for clean punches (blanks) spiked with 10-µL aliquots of alginic acid solution. Analyses done over a 7-week period. The middle horizontal line is the mean result (13.98 µg/cm²). The upper and lower dashed lines are ±5% of the mean.

Sets of diesel soot samples spiked with the alginic acid solution also were examined. Multiple punches (1.5 cm²) were taken from a soot sample collected on an 8” x 10” filter. The punches were then analyzed before and after spiking with a 10-µL aliquot of the solution. Punches in a given set were taken from the same area of the filter to minimize variability, and the solution was applied in a consistent manner (dispersed evenly on one end of the punch where the laser penetrates it). Mean TC results for the unspiked and spiked samples are provided in Table 2. Results for three sample sets (A, B, and C) are reported. For each set, the difference between the mean results for the unspiked and spiked samples is reported; this difference is the alginic acid carbon. Based on the mean (13.98 µg/cm²) for 22 spiked blanks, recoveries of alginic acid carbon from the soot samples were 96%, 101%, and 110% (sets A, B, and C, respectively). The pooled recovery for all spiked samples was 97%.

Table 2. Recovery of alginic acid carbon (means and standard deviations, n=3; µg/cm²) from unspiked diesel particulate samples and samples spiked with 10-µL alginic acid solution.

| Sample set | Unspiked | Spiked | Difference | Recovery* (%) |
|------------|-------------|-------------|------------|---------------|
| A | 22.9 (1.49) | 34.9 (0.66) | 13.5 | 96 |
| B | 22.3 (0.28) | 36.4 (0.65) | 14.1 | 101 |
| C | 22.6 (0.33) | 38.0 (0.80) | 15.4 | 110 |
| All | 22.6 (0.84) | 36.1 (1.32) | 13.5 | 97 |

*Based on mean result (14.0 µg/cm²) for 22 analyses of spiked blank punches; analyses carried out over a 7-week period.

Table 3. Results for elemental carbon (EC; means and standard deviations, $n=3$; $\mu\text{g}/\text{cm}^2$) from spiked and unspiked diesel particulate samples.

| Sample set | Unspiked | Spiked | Difference |
|------------|-------------|-------------|--------------|
| A | 4.24 (0.20) | 4.36 (0.42) | 0.12 (0.47) |
| B | 3.88 (0.01) | 3.78 (0.12) | -0.10 (0.12) |
| C | 4.32 (0.14) | 4.43 (0.12) | 0.11 (0.18) |

EC results for the three sample sets are listed in Table 3. Spiked sample results for two sets (A and C) were slightly higher, while those for a third set (B) were slightly lower.

Differences between the mean EC loadings on the unspiked and spiked samples were not statistically different. Thus, an accurate correction was again made for the char formed through pyrolysis of alginic acid.

k. Quality assurance

1.) NIOSH

Quality assurance (QA) procedures followed at NIOSH and NIOSH contract laboratories have included repeat analyses, analysis of OC standards, and analysis of media and field blanks. Results for repeat analyses of over 200 filter samples at a contract laboratory (DataChem Laboratories, Inc., Salt Lake City, UT) gave a pooled RSD (95% confidence) of about 4% for EC and TC, and 5% for OC [Birch et al. 1999a]. The samples were collected in mines, and some contained other carbonaceous matter such as limestone. In the analysis of OC standards, recovery was typically within 6% of the expected value [Birch et al. 1999a]. For example, the mean recovery for more than 400 sucrose standards analyzed at DataChem over a one-year period was 99.97% $\pm 6.07\%$. Nearly identical results (100.33% $\pm 5.15\%$, $n = 462$) were obtained by Clayton Laboratory Services (Novi, MI). Different sets of field blanks (41 at DataChem and 129 at Clayton) analyzed by the two laboratories also gave comparable results [Birch et al. 1999a]. Mean blank results (μg carbon per filter) were as follows: DataChem OC = 9.96 ± 7.05 , Clayton OC = 12.80 ± 5.76 ; DataChem EC = -0.54 ± 1.89 , Clayton EC = -0.08 ± 2.14 ; DataChem TC = 9.26 ± 7.30 , Clayton TC = 12.70 ± 6.18 .

In lieu of an OC-EC reference material, a limited confirmation of results by a second laboratory is advised. For example, our laboratory (NIOSH, Cincinnati, OH) has routinely performed repeat analyses on samples previously analyzed at a contract laboratory. As an added check, subsets of representative field samples also have been analyzed by a third laboratory. In the analysis of fifty samples (analyzed at DataChem, NIOSH, and Clayton) from mines, the pooled RSD (95% confidence) was about 6% for TC, 10% for EC, and 12% for OC [Birch et al. 1999a]. These results are consistent with those found in a previous round robin [Birch 1998a].



2.) EPA

The EPA conducted a special study [EPA 2001] as part of the QA oversight for the PM_{2.5} Speciation Trends Network (STN). Samples collected as part of this network were removed from refrigerated storage eight months after they were analyzed at Research Triangle Institute (RTI, Research Triangle Park, NC). The samples were then shipped to the EPA New England Regional Laboratory (NERL, Lexington, MA) for reanalysis. Good interlaboratory agreement was reported. The acceptance criteria for the archived samples were based on filter loading ($\mu\text{g}/\text{cm}^2$). The three acceptance criteria are the following: a difference $\leq 1 \mu\text{g}/\text{cm}^2$ for loadings less than $5 \mu\text{g}/\text{cm}^2$, a relative percent difference (RPD) $\leq 20\%$ for loadings from 5 to $10 \mu\text{g}/\text{cm}^2$, and an RPD $\leq 15\%$ for loadings above $10 \mu\text{g}/\text{cm}^2$. The OC, EC, and TC data had 85%, 96%, and 93% of the interlaboratory results, respectively, within the acceptance criteria. The lower percentages for OC and TC are thought to reflect contamination of lightly loaded samples from adsorbed vapors and handling. An OC blank (passive) correction was applied but may not have been representative of the entire sample set. Additional comparison results are discussed in the next section: Interlaboratory Comparisons.

3 Interlaboratory comparisons

a. NIOSH 5040

When results of the initial method evaluation were published [Birch and Cary 1996a], an interlaboratory comparison was not possible because the thermal-optical instrument was available in only one laboratory. Interlaboratory comparisons are especially important in this type of analysis because variable results have been obtained by different OC-EC methods [e.g., Birch 1998a; Chow et al. 2001; Countess 1990; Norris et al. 1999; Schmid et al. 2001;], and a reference material is not available. After additional laboratories acquired thermal-optical instruments, a round robin comparison [Birch 1998a] was conducted. Matched sets of filter samples containing different types of complex carbonaceous aerosols were distributed to eleven laboratories. Six of the eleven analyzed the samples according to NIOSH 5040, while five used purely thermal (i.e., no char correction) methods. Good interlaboratory agreement was obtained among the six laboratories that used NIOSH 5040. In the analysis of samples containing DPM, the variability (RSD) for the EC results ranged from 6% to 9%. Only low EC fractions were found in wood and cigarette smokes. Thus, these materials pose minimal interference in the analysis of diesel-source EC. In addition, only minor amounts of EC were found in two OC standards that char: about 1% and 0.1% for sucrose and the disodium salt of ethylenediaminetetraacetic acid (EDTA), respectively. Two aqueous solutions of OC standards were included in the comparison as a check on the validity of the char correction and accuracy of the TC results. Variability (RSD) of the TC results for the two standard solutions and five filter samples ranged from 3% to 6%.



Note: In the round-robin study [Birch et al. 1996a] discussed above, the maximum temperature in helium ranged from about 850 °C to 900 °C. Comparable results were obtained because some differences in the thermal program do not affect the results significantly (e.g., also see Chai et al. 2012). For the purpose of standardization, use of the same maximum is recommended.

Results of other interlaboratory comparisons on NIOSH 5040 have been reported. In one study [Schauer et al. 2001], seven environmental aerosol samples were analyzed in duplicate by eight laboratories. Four samples were collected in U.S. cities, and three were collected in Asia. Variability of the EC results ranged from 6% to 21% for six samples having EC loadings from 0.7 to 8.4 $\mu\text{g}/\text{cm}^2$. Four of the six had low EC loadings (0.7 $\mu\text{g}/\text{cm}^2$ to 1.4 $\mu\text{g}/\text{cm}^2$). The variability of the OC results ranged from 4% to 13% (OC loadings ranged from about 1 to 25 $\mu\text{g}/\text{cm}^2$). Results for TC were not reported, but the variability reported for the OC results should be representative of that for TC because the samples were mostly OC (75% to 92%). For another comparison [Chai et al. 2012], matched-filter sets with known OC–EC contents were generated and distributed to six laboratories. In this study, the maximum temperature in helium varied from 650 °C to 850 °C, but good agreement between the participating laboratories was found. Results indicated a uniform carbon distribution for the filter sets. Relative standard deviations for mean TC, OC, and EC results for seven laboratories were less than 10%, 11%, and 12% (respectively). Except for one EC result (RSD = 16%), RSDs reported by individual laboratories, for TC, OC, and EC, were under 12%. The method of filter generation is generally applicable and reproducible. Depending on the application, different filter loadings and types of OC materials can be employed. Matched filter sets can be used for determining the accuracy of OC–EC methods, which are operational.

b. Other methods

1.) Thermal methods

Different thermal methods have given consistent agreement for TC, but OC-EC results have been quite variable [Birch 1998a; Chow et al. 2001; Countess 1990; Norris et al. 1999; Schmid et al. 2001]. The degree of variability depends on the sample type. In general, there is greater disagreement among methods when samples contain materials that char [Birch 1998a; Countess 1990; Schmid et al. 2001] (e.g., wood and cigarette smokes). Methods that employ a lower maximum temperature and/or do not correct for char obtain results that are positively biased relative to NIOSH 5040 [Birch 1998a]. When a lower temperature (typically 550 °C) is used, less thermal breakdown of refractory organic components (and possibly carbonates) may occur. This, as well as lack of char correction, can positively bias the EC results. In the round robin study [Birch 1998a] discussed above, three laboratories employed four purely thermal

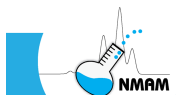

methods that specified a maximum in nitrogen (not helium) of about 550 °C. Unlike the NIOSH 5040 results, these laboratories reported high EC contents for the two OC standards (about 52% for sucrose and 70% for EDTA). Similar findings (i.e., positive bias) for thermal methods having no char correction were obtained in another international round robin [Schmid et al. 2001].

In contrast to round-robin results obtained previously [Birch 1998a], relatively good agreement was found in a comparison [Birch et al. 1999b] between NIOSH 5040 and a thermal method, ZH 1/120.44, used in Germany [Dahmann 1997; ZH 1/120.44]. The comparison was limited to two laboratories. Method ZH 1/120.44 specified a 550 °C maximum in nitrogen. The other European laboratories that participated in the previous round robin [Birch 1998a] used variations of this method. In the European laboratories, nitrogen was used as the inert gas, and carbon determination was based on coulometric titration of carbon dioxide. For the comparison [Birch et al. 1999b], samples were obtained in a mine where diesel equipment was being operated. The samples had a much higher EC content (about 50%) than did the round robin samples. No charring was noted in the thermograms, and only a minor amount of carbon was removed above 550 °C. Although differences in the OC-EC results were again seen, they were minor relative to those obtained in the round robin [Birch 1998a]. The mean EC fractions (EC:TC) found with methods ZH 1/120.44 and NIOSH 5040 were 0.53 ($\sigma = 0.19$) and 0.46 ($\sigma = 0.15$), respectively. This relatively minor difference in the reported fractions is attributed to the different thermal programs employed.

2.) IMPROVE method

Another thermal-optical method, called the IMPROVE (Interagency Monitoring of Protected Visual Environments) method [Chow et al. 1993], also was included in the NIOSH 5040 round robin [Birch 1998a]. Relatively good agreement between NIOSH 5040 and the IMPROVE method was obtained, although the IMPROVE EC was consistently higher. The carbon analyzers used for the two methods are based on similar measurement principles, but they differ with respect to design and operation. For example, the optical correction in NIOSH 5040 is based on filter transmittance, whereas that for the IMPROVE method is reflectance based. When the intercomparison study was conducted, the instrument (Sunset Laboratory, Inc., Forest Grove, OR) used for NIOSH 5040 incorporated a pulsed diode laser (670 nm) and photodetector positioned on opposite sides of the filter, while the Desert Research Institute (DRI, Reno, NV) instrument employed for the IMPROVE method used a quartz tube and fiber optic to measure helium–neon laser light (632.8 nm, unmodulated) reflected from the filter surface. In addition to instrumental differences, NIOSH 5040 specifies a higher maximum temperature (typically 850 °C or higher) in helium than the IMPROVE method (550 °C). As discussed in the preceding section, a

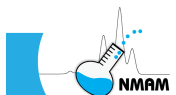

higher temperature is used to better remove refractory OC components and carbonates. In the NIOSH 5040 analysis, the transmittance of some samples continues to decrease as the temperature is stepped to 850 °C, indicating further carbonization above 550 °C. Additional thermal breakdown and charring result in lower EC results because char correction is larger, and volatile pyrolysis products are released to a greater extent. Although environmental samples contain only small amounts (if any) of carbonate, levels in some workplaces (e.g., mines, construction sites) can be relatively high. Collection of carbonate can be prevented (or minimized) through use of an impactor [66 Fed. Reg. 5706 (2001)].

Results of two other comparisons [Chow et al. 2001; Norris et al. 1999] between NIOSH 5040 and the IMPROVE method have been reported. In one [Chow et al. 2001], the NIOSH 5040 EC was typically less than half the IMPROVE EC; however, a Sunset Laboratory instrument was not used. Instead, samples were analyzed with a DRI instrument, by running two different thermal programs [Chow et al. 2001]. Because differences in instrument design affect the OC-EC results to varying degrees, depending on sample type, the results reported for NIOSH 5040 (emulated on a DRI instrument) may not be representative of those obtained with a Sunset Laboratory instrument. Adjustment of the temperature program, according to another method's specifications, does not necessarily produce the same results as that method. For example, lower EC results [Birch 1998a] were obtained with a Sunset Laboratory instrument when a sucrose standard was analyzed according to the temperature program specified for a method used in Europe. No pyrolysis correction was made, and the total analysis time was shorter, yet the EC result was much lower (about 3 µg with the Sunset instrument and 11 µg with a different instrument).

When the NIOSH 5040 thermal program was used on a DRI instrument, the filter transmittance reportedly exceeded its initial value before the addition of oxygen [Chow et al. 2001]. In an audit by a CARB (California Air Resources Board) laboratory, the same problem was seen with a DRI instrument, but not a Sunset Laboratory instrument [EPA 2003]. Char loss was extensive when the NIOSH 5040 program was used on a DRI instrument. Again, the filter transmittance exceeded its initial value in helium, but the split point was not assigned until after oxygen was introduced. These results contrast with those obtained by our laboratory and others, and such behavior was not seen in another comparison [Norris et al. 1999]; however, that comparison (and the CARB audit) was a direct comparison of the two methods (i.e., samples were analyzed with both Sunset and DRI instruments). Only 2 of 52 samples analyzed by Sunset Laboratory showed an increase in transmittance before the addition of oxygen, and the OC-EC split was near the point where oxygen was added [Norris et al. 1999]. Both samples had low carbon loadings (OC = 4.0 µg/cm², EC = 0.6 µg/cm²,

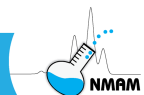

OC = 3.3 $\mu\text{g}/\text{cm}^2$, EC = 0.5 $\mu\text{g}/\text{cm}^2$) and were thought to be wood-smoke dominated. As pyrolysis was evident, the increase in filter transmittance was attributed to char loss. Comparable EC results would have been obtained if the char had not been removed until after oxygen was added, because char is assigned to the OC fraction. In the NIOSH 5040 analysis of organic compounds (e.g., sucrose), partial char loss in helium sometimes occurs. The varying degree of loss may relate to differences in filter purity.

4 Occupational exposure criteria (U.S.)

In 1995, the American Conference of Governmental Industrial Hygienists (ACGIH) proposed a Threshold Limit Value (TLV[®]) for diesel exhaust [ACGIH 1995] (see Notice of Intended Changes for 1995–1996). A TLV of 150 μg of submicrometer particulate matter (mass) per cubic meter of air was proposed. Four years later, a value of 50 $\mu\text{g}/\text{m}^3$ was proposed [ACGIH 1999]. An EC-based standard was later proposed, because EC is a demonstrated exposure marker and can be accurately quantified at low levels [ACGIH 2001a]. A TLV-TWA (time-weighted average) of 20 μg EC per cubic meter of air was recommended [ACGIH 2001b]. By comparison, the proposed TLV was high relative to an environmental standard supported by the California Office of Environmental Health Hazard Assessment (OEHHA). The California OEHHA classified particulate emissions from diesel-fueled engines as a toxic air contaminant (TAC) and supported 5 $\mu\text{g}/\text{m}^3$ as the chronic inhalation reference exposure level (REL) [CalEPA 1998]. Because EC is a fraction of the diesel particulate emissions, the difference between the two air standards is greater than four fold, with the magnitude of the difference being dependent on the EC fraction of the diesel particulate mass. For example, if EC constituted 40% of the mass, the proposed TLV would be ten times higher than the OEHHA REL.

An exposure limit for DPM has been promulgated for metal and nonmetal mines, but there currently are no limits for other occupational settings (ACGIH withdrew a proposed limit [ACGIH 2003] for DPM [as EC] from its Notice of Intended Changes [NIC] list in 2003 and placed it under study). An EC (or TC) standard, rather than submicrometer particulate mass, would simplify interpretation of the analytical results because the target analyte and exposure standard would be the same. This would eliminate the problem of extrapolation (to submicrometer mass), which is not straightforward and introduces unacceptable error. As discussed previously, OC interferences are a problem with TC measurements; variable EC content is a problem when measuring EC. If EC concentrations are high and samples are relatively free of OC contaminants, the TC concentration is a reasonable measure of the diesel particulate mass, and the EC:TC ratio is representative of the EC fraction of the mass. However, this situation is uncommon outside of mines. In general industry, EC and OC levels are normally much lower. And when EC levels are low, the EC:TC ratios are not reliable estimates of the EC fraction of DPM because OC interferences can skew the ratios low and

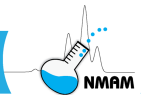

increase variability in the apparent ratio. In such cases, TC is an inaccurate measure of the diesel particulate concentration.

Exposures in the mining industry are of particular concern because diesel particulate concentrations in mines [63 Fed. Reg. 17491 (1998); 63 Fed. Reg. 58103 (1998); 66 Fed. Reg. 5706 (2001)] have sometimes exceeded 2 mg/m^3 , which is one thousand times higher than a typical environmental level. In its final rule [66 Fed. Reg. 5706 (2001)] on metal and nonmetal mines, MSHA proposed an interim exposure standard of $400 \text{ } \mu\text{g TC per cubic meter of air}$. Five years after publication of the rule, a final standard of $150 \text{ } \mu\text{g TC per cubic meter}$ was to apply. In response to a legal challenge, MSHA initiated a limited new rulemaking [67 Fed. Reg. 60199 (2002)] to revise certain provisions of the final rule. Among other amendments, MSHA agreed to propose a change of exposure surrogate from TC to EC. Comments on appropriate interim and final limits for EC were requested in the new rulemaking. MSHA exposure standards consider health risks and technical and economic feasibility, based on available engineering controls and their cost.

5 Summary

NIOSH 5040 is based on a thermal-optical analysis technique for particulate carbon. Its intended application is assessment of workplace exposure to particulate diesel exhaust, but thermal-optical analysis has been routinely applied to environmental carbonaceous aerosols. Both OC and EC (and TC as $\text{OC} + \text{EC}$) are determined by the method. For reasons discussed in this chapter, EC was selected as an exposure surrogate for diesel exhaust. Over 30 epidemiological studies are consistent in finding a positive association between exposure to diesel exhaust and lung cancer, but many studies lack quantitative exposure data. Accurate monitoring methods are necessary for quantifying the exposure risks.

The thermal-optical instrument incorporates an optical feature that corrects for the char formed during the analysis of some materials. The EC results of purely thermal methods show positive bias when samples contain such materials. Although minimal charring has been observed with most diesel soot samples from mines, workplace (and environmental) air often contains components that carbonize. Depending on the workplace and thermal protocol, these components can be significant contributors to the measured EC. For this reason, an analytical protocol that maximizes removal of OC components (and carbonates) and corrects for the char formed through thermal decomposition is important. In the NIOSH 5040 analysis, the transmittance/reflectance of some samples continues to decrease as the temperature is stepped to $850 \text{ } ^\circ\text{C}$ (and higher) in helium, which indicates incomplete carbonization at the lower temperatures used in some methods. Partial char loss may occur in helium at higher temperature, but removal of original EC is less common. Good interlaboratory agreement between OC-EC results has been obtained by laboratories using



NIOSH 5040. Because a certified reference material is not currently available, confirmation of results by a second laboratory using NIOSH 5040 is advised, particularly when samples char during the analysis because interlaboratory results for these types of samples are typically more variable. Organic materials that char are useful as quality control samples. Accurate pyrolysis correction was obtained in the NIOSH 5040 analysis of an alginic acid solution spiked onto blank filters and diesel soot samples. Sucrose has traditionally been used as a check on the method's char correction, but other materials are needed that are more representative of the complex components in air samples.

To ensure data quality, participation in proficiency testing among laboratories involved in major studies also is advised. Several commercial laboratories offer the NIOSH 5040 analysis, and many instruments have been used globally for environmental and occupational monitoring. Method standardization is critical if results obtained by different laboratories are to be compared. Interlaboratory studies are useful in exposing differences among methods, but standards need to be included to identify method biases. Results of such comparisons must be interpreted with a clear understanding of each method's limitations.

Continued research is needed to better assess the potential health effects of diesel exhaust and other types of fine/ultrafine particle pollution. Although the organic compounds associated with DPM have potential health effects, those traditionally measured are not unique to diesel exhaust. Nevertheless, characterization of this fraction may be useful in assessment of exposure risks, particularly if compounds enriched in diesel relative to other particulate emissions can be used as indicators of mutagenic potency (e.g., specific nitro-PAH). This information also may identify engine types and operating conditions that produce higher emission rates of genotoxic compounds.

As reasoned previously [Birch and Cary 1996a], regardless of whether the potential adverse health effects of diesel particles are due to their tiny, carbonaceous cores, adsorbed compounds, or a combination of both, monitoring and control of the particulate component are necessary if the effects are particle related. In most workplaces, diesel engines are the primary source of fine-particle EC. Other combustion sources may contribute to environmental levels of EC. These sources may be relevant from an emission control perspective, but if the potential toxicity of the particles is similar, their origin is not relevant from a health perspective.

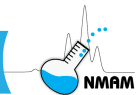

Disclaimer

Mention of any company or product does not constitute endorsement by NIOSH. In addition, citations to websites external to NIOSH do not constitute NIOSH endorsement of the sponsoring organizations or their programs or products. Furthermore, NIOSH is not responsible for the content of these websites. All web addresses referenced in this document were accessible as of the publication date.

6 References

52 Fed. Reg. 24634 [1987]. Environmental Protection Agency: Revisions to the national ambient air quality standards for particulate matter. Washington, DC: U.S. Government Printing Office, Office of the Federal Register. (To be codified at 40 CFR 51 and 52.)

55 Fed. Reg. 110 [1990]. Centers for Disease Control and Prevention (CDC), National Institute for Occupational Safety and Health (NIOSH): Sampling and analysis of airborne diesel exhaust particulates; peer review meeting. Washington, DC: U.S. Government Printing Office, Office of the Federal Register.

62 Fed. Reg. 38652 [1997]. Environmental Protection Agency: National ambient air quality standards for particulate matter; final rule. Washington, DC: U.S. Government Printing Office, Office of the Federal Register. (To be codified at 40 CFR 50.)

63 Fed. Reg. 17491 [1998]. Mine Safety and Health Administration: Diesel particulate matter exposure of underground coal miners; proposed rule. Washington, DC: U.S. Government Printing Office, Office of the Federal Register. (To be codified at 30 CFR 72 and 75.)

63 Fed. Reg. 58103 [1998]. Mine Safety and Health Administration: Diesel particulate matter exposure of underground metal and nonmetal miners; proposed rule. Washington, DC: U.S. Government Printing Office, Office of the Federal Register. (To be codified at 30 CFR 57.)

66 Fed. Reg. 5706 [2001]. Mine Safety and Health Administration: Diesel particulate matter exposure of underground metal and nonmetal miners; final rule. Washington, DC: U.S. Government Printing Office, Office of the Federal Register. (To be codified at 30 CFR 57.)

67 Fed. Reg. 60199 [2002]. Mine Safety and Health Administration: Diesel particulate matter exposure of underground metal and nonmetal miners; advanced notice of proposed rulemaking. Washington, DC: U.S. Government Printing Office, Office of the Federal Register. (To be codified at 30 CFR 57.)

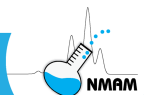

ACGIH [1995]. 1995-1996 Threshold Limit Values for chemical substances and physical agents & Biological Exposure Indices. Cincinnati, OH: American Conference of Governmental Industrial Hygienists.

ACGIH [1999]. 1998 annual reports of the committees on threshold limit values (TLVs) and biological exposure indices (BEI), notice of intended changes for 1999. ACGIH Today 6(8):1-2. Cincinnati, OH: American Conference of Governmental Industrial Hygienists.

ACGIH [2001a]. 2000 annual reports of the committees on TLVs and BEIs, notice of intended changes for 2001. ACGIH Today 9(1). Cincinnati, OH: American Conference of Governmental Industrial Hygienists.

ACGIH [2001b]. Diesel exhaust (particulate and particulate adsorbed components), draft TLV-TWA document. Cincinnati, OH: American Conference of Governmental Industrial Hygienists.

ACGIH [2003]. Press release (January 27, 2003): ACGIH board ratifies 2003 TLVs and BEIs. Cincinnati, OH: American Conference of Governmental Industrial Hygienists.

Attfield MD, Schlieff PL, Lubin JH et al. [2012]. The Diesel exhaust in miners study: a cohort mortality study with emphasis on lung cancer. *J Natl Cancer Inst* 104(11):869-883.

Birch ME [1991]. Research protocol: A sampling and analytical method for airborne diesel-exhaust particles. Cincinnati, OH: U.S. Department of Health and Human Services, Public Health Service, Centers for Disease Control, National Institute for Occupational Safety and Health. Unpublished.

Birch ME [1998a]. Analysis of carbonaceous aerosols--interlaboratory comparison. *Analyst* 123:851-857.

Birch ME [1998b]. Elemental carbon loss in helium during NIOSH 5040 analysis of total and respirable dust samples from potash mines. Cincinnati, OH: U.S. Department of Health and Human Services, Public Health Service, Centers for Disease Control and Prevention, National Institute for Occupational Safety and Health. Unpublished.

Birch ME [2011]. Exposure and emissions monitoring during carbon nanofiber production. Part II: polycyclic aromatic hydrocarbons. *Ann Occup Hyg* 55(9):1037-1047.

Birch ME, Cary RA [1996a]. Elemental carbon-based method for monitoring occupational exposures to particulate diesel exhaust. *Aerosol Sci Technol* 25:221-241.



Birch ME, Cary RA [1996b]. Elemental carbon-based method for occupational monitoring of particulate diesel exhaust: Methodology and exposure issues. *Analyst* 121:1183-1190.

Birch ME, Schlecht PC, Epstein PS, Rentschler M [1999a]. NIOSH 5040--A rugged method for measuring occupational exposures to diesel particulate matter. Unpublished paper presented at the American Industrial Hygiene Conference and Exposition, Toronto, Canada, June 5-11, 1999.

Birch ME, Dahmann D, Fricke H-H [1999b]. Comparison of two carbon analysis methods for monitoring diesel particulate levels in mines. *J Environ Monit* 1:541-544.

Birch ME, Ku B-K, Evans DE, Ruda-Eberenz T [2011]. Exposure and emissions monitoring during carbon nanofiber production. Part I: elemental carbon and iron-soot aerosols. *Ann Occup Hyg* 55(9):1016-1036.

Bjorseth A, Becher G [1986]. Physical and chemical properties of PAH. In: PAH in work atmospheres: Occurrence and determination. Boca Raton, FL: CRC Press.

Brown LM, Collings N, Harrison RM, Maynard AD, Maynard RL, eds. [2000]. Discussion meeting on ultrafine particles in the atmosphere. *Philos Trans R Soc London A* 358(1775):2561-2797.

Burnett RT, Dales R, Krewski D, Vincent R, Dann T, Brook JR [1995]. Associations between ambient particulate sulfate and admissions to Ontario hospitals for cardiac and respiratory diseases. *Am J Epidemiol* 142:15-22.

Cadle SH, Mulawa PA [1990]. Atmospheric carbonaceous species measurement methods comparison study. *Aerosol Sci Technol* 12(1):128-141.

California EPA [1998]. Proposed identification of diesel exhaust as a toxic air contaminant--part B: Health risk assessment for diesel exhaust. Sacramento, CA: California Environmental Protection Agency, Office of Environmental Health Hazard Assessment.

Cass GR, Gray HA [1995]. Regional emissions and atmospheric concentrations of diesel engine particulate matter: Los Angeles as a case study. In: Diesel exhaust: A critical analysis of emissions, exposure, and health effects. Cambridge, MA: Health Effects Institute, pp. 125-137.

Chai M, Birch ME, Deye G [2012]. Organic and elemental carbon filter sets: Preparation method and interlaboratory results. *Ann Occup Hyg* 56(8):959-967.



Chow JC, Watson JG, Crow D, Lowenthal DH, Merrifield T [2001]. Comparison of IMPROVE and NIOSH carbon measurements. *Aerosol Sci Technol* 34:23-34.

Chow JC, Watson JG, Pritchett LC, Pierson WR, Frazier CA, Purcel RG [1993]. The DRI thermal/optical reflectance carbon analysis system--description, evaluation and applications in U.S. air quality studies. *Atmos Environ* 27A(8):1185-1201.

Countess RJ [1990]. Interlaboratory analyses of carbonaceous aerosol samples. *Aerosol Sci Technol* 12:114-121.

Cui W, Eatough DJ, Eatough NL [1998]. Fine particulate organic material in the Los Angeles basin--1: Assessment of the high-volume Brigham Young University Organic Sampling System, BIG BOSS. *J Air Waste Manag Assoc* 48:1024-1037.

Currie LA, Benner BA, Jr., Kessler JD, Klinedinst DB, Klouda GA, Marolf JV, Slater JF, Wise SA, Cachier H, Cary R, Chow JC, Watson J, Druffel ERM, Masiello CA, Eglinton TI, Pearson A, Reddy CM, Gustafsson O, Hartmann PC, Quinn JG, Hedges JI, Prentice KM, Kirchstetter TW, Novakov T, Puxbaum H, Schmid H [2002]. A critical evaluation of interlaboratory data on total, elemental, and isotopic carbon in the carbonaceous particle reference material, NIST SRM 1649a. *J Res Natl Inst Stand Technol* 107(3):279-298.

Dahm MM, Evans DE, Schubauer-Berigan MK, Birch ME, Fernback JE [2012]. Occupational exposure assessment in carbon nanotube and nanofiber primary and secondary manufacturers. *Ann Occup Hyg* 56(5):542-56.

Dahm MM, Schubauer-Berigan MK, Evans DE, Birch ME, Fernback JE, Deddens JA [2015]. Carbon nanotube and nanofiber exposure assessments: An analysis of 14 site visits. *Ann Occup Hyg* 59(6):705-723.

Dahmann D, Bauer H-D [1997]. Diesel particulate matter (DPM) in workplaces in Germany. *Appl. Occup. Environ. Hyg.* 12(12):1028-1031.

Dockery DW, Pope CA, III, Xu X, Spengler JD, Ware JH, Fay ME, Ferris BG, Jr., Speizer FE [1993]. An association between air pollution and mortality in six U.S. cities. *N Engl J Med* 329:1753-1759.

Donaldson K, Stone V, Gilmour PS, Brown DM, MacNee W [2000]. Ultrafine particles: Mechanisms of lung injury. *Philos Trans R Soc London A* 358(1775):2741-2749.



Doudrick K, Herckes P, Westerhoff P [2012]. Detection of carbon nanotubes in environmental matrices using programmed thermal analysis. *Environ Sci Technol* 46:12246-12253.

Edwards J, Walters S, Griffiths RK [1994]. Hospital admissions for asthma in preschool children: Relationship to major roads in Birmingham, United Kingdom. *Arch Environ Health* 49:223-227.

EPA [1999]. Air quality criteria for particulate matter [external review draft]. Vol. 3. Washington, DC: U.S. Environmental Protection Agency, Office of Research and Development, EPA/600/P-99/002C.

EPA [2000a]. Health assessment document for diesel emission [review draft]. Washington, DC: U.S. Environmental Protection Agency, Office of Research and Development, EPA/600/8-90/057E.

EPA [2000b]. National air pollutant emission trends, 1900-1998. Research Triangle Park, NC: U.S. Environmental Protection Agency, Office of Air Quality Planning and Standards, EPA-454/R-00-002.

EPA [2001]. PM_{2.5} speciation trends network special study. Montgomery, AL: U.S. Environmental Protection Agency, Office of Radiation and Indoor Air, National Air and Radiation Environmental Laboratory.
[www.epa.gov/ttn/amtic/files/ambient/pm25/spec/sparchive.pdf] Date accessed: April 5, 2016.

EPA [2003]. CARB laboratory audit. Montgomery, AL: U.S. Environmental Protection Agency, National Air and Radiation Environmental Laboratory.
[www.epa.gov/ttnamti1/files/ambient/pm25/spec/carbrept.pdf] Date accessed: April 5, 2016.

Fatkhutdinova LM, Khaliullin TO, Vasil'yeva OL, Zalyalov RR, Mustafin IG, Kisin ER, Birch ME, Yanamala N, Shvedova AA [2016]. Fibrosis Biomarkers in Workers Exposed to MWCNT. *Toxicol Appl Pharmacol*, <http://dx.doi.org/10.1016/j.taap.2016.02.016>

Garshick E, Laden F, Hart JE, Rosner B, Smith TJ, Dockery DW, Spelzer FE [2004]. Lung Cancer in Railroad Workers Exposed to Diesel Exhaust. *Environ Health Perspect* 112(15):1539-1543.

Gray HA, Cass GR, Huntzicker JJ, Heyerdahl KK, Rau JA [1984]. Elemental and organic carbon particle concentrations: A long-term perspective. *Sci Total Environ* 36:17-25.



Grimmer GH, Brune H, Deutsch-Wentzel R, Naujack KW, Misfeld J, Timm J [1983]. On the contribution of polycyclic aromatic hydrocarbons to the carcinogen impact of automobile exhaust condensate evaluated by local application onto mouse skin. *Cancer Lett* 21:105-113.

Haney RA, Fields KG [1996]. In-mine comparison of diesel particulate sampling methods. *Appl Occup Environ Hyg* 11:717-720.

Hansen ADA, Novakov T [1990]. Real-time measurement of aerosol black carbon during the carbonaceous species methods comparison study. *Aerosol Sci Technol* 12(1):194-199.

HEI [1995]. Diesel exhaust: A critical analysis of emissions, exposure, and health effects. Cambridge, MA: Health Effects Institute.

HEI [2002]. Diesel Epidemiology Working Group. Research directions to improve estimates of human exposure and risk from diesel exhaust. Boston, MA: Health Effects Institute.

IARC [1989]. Diesel and gasoline engine exhausts and some nitroarenes. In: IARC monographs on the evaluation of carcinogenic risks to humans. Vol. 46. Lyon, France: World Health Organization, International Agency for Research on Cancer.

IARC, WHO [2012]. Press Release No. 213, 12 June 2012, IARC: "Diesel Engine Exhaust Carcinogenic" [http://www.iarc.fr/en/media-centre/pr/2012/pdfs/pr213_E.pdf]. Date accessed: Feb. 16, 2014.

Japar SM, Szkarlat AC, Gorse RA, Jr., Heyerdahl EK, Johnson RL, Rau JA, Huntzicker JJ [1984]. Comparison of solvent extraction and thermal-optical carbon analysis methods: Application to diesel vehicle exhaust aerosol. *Environ Sci Technol* 18:231-234.

Kennedy ER, Fischbach TJ, Song R, Eller PM, Shulman SA [1995]. Guidelines for air sampling and analytical method development and evaluation. Cincinnati, OH: U.S. Department of Health and Human Services, Public Health Service, Centers for Disease Control and Prevention, National Institute for Occupational Safety and Health, DHHS (NIOSH) Publication No. 95-117.

Kirchstetter TW, Corrigan CE, Novakov T [2001]. Laboratory and field investigation of the adsorption of gaseous organic compounds onto quartz. *Atmos Environ* 35:1663-1671.



Kittelson D, Watts W, Ramachandran G, Paulsen D, Kreager C [2002]. Measurement of diesel aerosol exposure: A feasibility study. In: Research directions to improve estimates of human exposure and risk from diesel exhaust. Boston, MA: Health Effects Institute, Diesel Epidemiology Working Group, pp. 153-179.

Kogut J, Tomb TF, Parobeck PS, Gero AJ, Suppers KL [1997]. Measurement precision with the coal mine dust personal sampler. *Appl Occup Environ Hyg* 12(12):999-1006.

Lies KH [1989]. Unregulated motor vehicle exhaust gas components. Wolfsburg, Germany: Volkswagen AG, Research and Development (Physico-Chemical Metrology).

Mannino DM, Homa DM, Pertowski CA, Ashizawa A, Nixon LL, Johnson CA, Ball LB, Jack E, Kang DS [1998]. Surveillance for asthma—United States, 1960-1995. *MMWR CDC Surveill Summ* 47:1-27.

Mazzuckelli LF, Methner MM, Birch ME, Evans DE, Ku B-K, Crouch K, Hoover MD [2007]. Identification and characterization of potential sources of worker exposure to carbon nanofibers during polymer composite laboratory operations. *J Occup Environ Hyg* 4:D125-D130.

McDow SR, Huntzicker JJ [1990]. Vapor adsorption artifact in the sampling of organic aerosol: Face velocity effects. *Atmos Environ* 24A:2563-2571.

Morrison RT, Boyd RN [1973]. Chapter 35. In: Organic chemistry. 3rd ed. Boston, MA: Allyn and Bacon.

Natusch D [1978]. Potentially carcinogenic species emitted to the atmosphere by fossil-fueled power plants. *Environ Health Perspect* 22:79-80.

Niessner R, Wilbring P [1989]. Ultrafine particles as trace catchers for polycyclic aromatic hydrocarbons: The photoelectric aerosol sensor as a tool for in situ sorption and desorption studies. *Anal Chem* 61:708-714.

NIOSH [1988]. Current intelligence bulletin 50: Carcinogenic effects of exposure to diesel exhaust. Cincinnati, OH: U.S. Department of Health and Human Services, Public Health Service, Centers for Disease Control, National Institute for Occupational Safety and Health, DHHS (NIOSH) Publication No. 88-116.



NIOSH [1992]. Hazard evaluation and technical assistance report: Empire Distributors, Inc., Atlanta, GA. Cincinnati, OH: U.S. Department of Health and Human Services, Public Health Service, Centers for Disease Control and Prevention, National Institute for Occupational Safety and Health, NIOSH HETA Report No. 92-226-2269, NTIS No. PB93-215085.

NIOSH [1993]. Hazard evaluation and technical assistance report: City of Lancaster, Division of Fire, Lancaster, OH. Cincinnati, OH: U.S. Department of Health and Human Services, Public Health Service, Centers for Disease Control and Prevention, National Institute for Occupational Safety and Health, NIOSH HETA Report No. 92-0160-2360, NTIS No. PB94-140142.

NIOSH [1994a]. Elemental carbon (diesel particulate): Method 5040 (supplement issued 1/15/98). In: NIOSH manual of analytical methods. 4th ed. Cincinnati, OH: U.S. Department of Health and Human Services, Public Health Service, Centers for Disease Control and Prevention, National Institute for Occupational Safety and Health, DHHS (NIOSH) Publication No. 94-113.

NIOSH [1994b]. Diesel particulate matter (as elemental carbon): Method 5040 (supplement issued 3/15/03). In: NIOSH manual of analytical methods. 4th ed. Cincinnati, OH: U.S. Department of Health and Human Services, Public Health Service, Centers for Disease Control and Prevention, National Institute for Occupational Safety and Health, DHHS (NIOSH) Publication No. 94-113.

NIOSH [1994c]. Hazard evaluation and technical assistance report, Southwest Airlines, Houston Hobby Airport, Houston, TX. Cincinnati, OH: U.S. Department of Health and Human Services, Public Health Service, Centers for Disease Control and Prevention, National Institute for Occupational Safety and Health, NIOSH HETA Report No. 93-0816-2371, NTIS No. PB94-175155.

NIOSH [2003]. Chapter Q: Monitoring of diesel particulate exhaust in the workplace. In: Schlecht PC, O'Connor PF, eds. NIOSH manual of analytical methods. 4th ed. Cincinnati, OH: U.S. Department of Health and Human Services, Centers for Disease Control and Prevention, National Institute for Occupational Safety and Health, DHHS (NIOSH) Publication No. 2003-154.

NIOSH [2013]. [2013]. Current intelligence bulletin 65: occupational exposure to carbon nanotubes and nanofibers. By Zumwalde R, Kuempel E, Birch ME, Trout D, Castranova V. Cincinnati, OH: U.S. Department of Health and Human Services, Centers for Disease Control and Prevention, National Institute for Occupational Safety and Health, DHHS (NIOSH) Publication No. 2013-145.

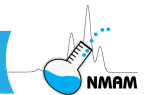

NIST [2001]. Certificate of analysis: Standard reference material 1649a – Urban dust. Washington, DC: U.S. Department of Commerce, National Institute of Standards & Technology.

Norris GA, Birch ME, Tolocka MP, Lewis CS, Solomon PA, Homolya JB [1999]. Analysis of carbonaceous aerosols using the thermal optical transmittance and thermal optical reflectance methods. In: Proceedings of the 92nd Annual Meeting of the Air & Waste Management Association, St. Louis, MO, June 20-24, 1999. NTIS No. PB99-171597.

NTP [2000]. Report on carcinogens. 9th ed. Research Triangle Park, NC: U.S. Department of Health and Human Services, Public Health Service, National Toxicology Program.

Pandya RJ, Solomon G, Kinner A, Balmes JR [2002]. Diesel exhaust and asthma: Hypotheses and molecular mechanisms of action. *Environ Health Perspect* 110(Suppl 1):103-112.

Pierson WR, Brachaczek WW [1983]. Particulate matter associated with vehicles on the road, II. *Aerosol Sci Technol* 2:1-40.

Pope CA, III, Dockery DW, Schwartz J [1995a]. Review of epidemiological evidence of health effects of particulate air pollution. *Inhal Toxicol* 7(1):1-18.

Pope CA, III, Thun MJ, Namboodiri MM, Dockery DW, Evans JS, Speizer RE, Heath CW [1995b]. Particulate air pollution as a predictor of mortality in a prospective study of U.S. adults. *Am J Respir Crit Care Med* 151:669-674.

Pope CA, III, Burnett RT, Thun MJ, Calle EE, Krewski D, Ito K, Thurston GD [2002]. Lung cancer, cardiopulmonary mortality, and long-term exposure to fine particulate air pollution. *J Am Med Assoc* 287(9):1132-1141.

Pott F [1985]. Pyrolyseabgase, PAH und Lungenkrebsrisiko– Daten und Bewertung. (Pyrolysis gases, PAH and risk of lung cancer – Data and evaluation.) *Staub - Reinhalt Luft* 45:369-379.

Samet JM [2000]. Fine particulate air pollution and mortality in 20 U.S. cities. *N Engl J Med* 343(24):1742-1749.

Sawyer RF, Johnson JJ [1995]. Diesel emissions and control technology. In: Diesel exhaust: A critical analysis of emissions, exposure, and health effects. Cambridge, MA: Health Effects Institute, pp. 65-81.

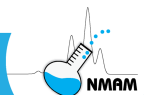

Schauer JJ, Mader BT, DeMinter JT, Heidemann G, Bae MS, Seinfeld JH, Flagan RC, Cary RA, Smith D, Huebert BJ, Bertram T, Howell S, Kline JT, Quinn P, Bates T, Turpin B, Lim HJ, Yu JZ, Yang H, Keywood MD [2001]. ACE-Asia intercomparison of a thermal-optical method for the determination of particle-phase organic and elemental carbon. *Environ Sci Technol* 37(5):993-1001.

Schmid H, Laskus L, Jürgen Abraham H, Baltensperger U, Lavanchy V, Bizjak M, Burba P, Cachier H, Crow D, Chow J, Gnauk T, Even A, ten Brink HM, Giesen K-P, Hitzenberger R, Hueglin C, Maenhaut W, Pio C, Carvalho A, Putaud J-P, Toom-Sauntry D, Puxbaum H [2001]. Results of the "carbon conference" international aerosol carbon round robin test stage I. *Atmos Environ* 35(12):2111-2121.

Schuetzle D [1983]. Sampling of vehicle emissions for chemical analysis and biological testing. *Environ Health Perspect* 47:65-80.

Schwartz J [1997]. Health effects of air pollution from traffic: Ozone and particulate matter. In: Fletcher T, McMichael AJ, eds. *Health at the crossroads: Transport policy and urban health*. Chichester, UK: Wiley.

Schwartz J, Dockery DW, Neas LM [1996]. Is daily mortality associated specifically with fine particles? *J Air Waste Manag Assoc* 46:937-939.

Schwartz J [1994]. Air pollution and hospital admissions for the elderly in Birmingham, AL. *Am J Epidemiol* 139:589-590.

Schwartz J, Morris R [1995]. Air pollution and hospital admissions for cardiovascular disease in Detroit, Michigan. *Am J Epidemiol* 142:22-35.

Silverman, DT; Samanic, CM; Lubin, JH, et al. [2012]. The diesel exhaust in miners study: a nested case-control study of lung cancer and diesel exhaust. *J. Natl. Cancer Inst.* 104(11):855-868.

Solomon GM, Campbell TR, Carmichael T, Feuer GR, Hathaway JS [1998]. *Exhausted by diesel: How America's dependence on diesel engines threatens our health*. New York: Natural Resources Defense Council.

Stanevich RS, Hintz P, Yareb D [1997]. Elemental carbon levels at a potash mine. *Appl Occup Environ Hyg* 1:1009-1012.



Sun J, Wolff R, Kanapilly G [1982]. Deposition, retention, and biological fate of inhaled benzo(a)pyrene adsorbed onto ultrafine particles and as a pure aerosol. *Toxicol Appl Pharmacol* 65:231-241.

Thrane KE, Mikalsen A, Stray H [1985]. Monitoring methods for airborne polycyclic aromatic hydrocarbons. *Int J Environ Anal Chem* 23(1-2):111-134.

Turpin BJ, Huntzicker JJ, Hering SV [1994]. Investigation of organic aerosol sampling artifacts in the Los Angeles basin. *Atmos Environ* 28(19):3061-3071.

van Vliet P, Knape M, de Hartog J, Janssen NAH, Harssems H, Brunekreef B [1997]. Air pollution from road traffic and chronic respiratory symptoms in children living near motorways. *Environ Res* 74:122-132.

Verma DK, Shaw L, Julian JA, Smolyneec K, Wood C, Shaw D [1999]. A comparison of sampling and analytical methods for assessing occupational exposure to diesel exhaust in a railroad work environment. *Appl Occup Environ Hyg* 14:701-714.

Weiland SK, Mundt KA, Rückmann A, Keil U [1994]. Self-reported wheezing and allergic rhinitis in children and traffic density on street of residence. *Ann Epidemiol* 4:243-247.

WHO, International Programme on Chemical Safety [1996]. Environmental health criteria 171: Diesel fuel and exhaust emissions. Geneva, Switzerland: World Health Organization.

Whittaker LS, MacIntosh PL, Williams PL [1999]. Employee exposure to diesel exhaust in the electric utility industry. *Am Ind Hyg Assoc J* 60:635-640.

Wjst M, Reitmeir P, Dold S [1993]. Road traffic and adverse health effects on respiratory health in children. *Br Med J* 307:596-600.

Wolff RK, Henderson RF, Snipes MB, Sun JD, Bond JA, Mauderly JL, McClellan RO [1986]. Lung retention of diesel soot and associated organic compounds. In: Ishinishi N, Koizumi A, McClellan RO, Stöber W, eds. *Carcinogenic and mutagenic effects of diesel engine exhaust*. Amsterdam: Elsevier, pp. 199-211.

Yamasaki H, Kuwata K, Miyamoto H [1982]. Effects of ambient temperature on aspects of airborne polycyclic aromatic hydrocarbons. *Environ Sci Technol* 16(4):189-194.



Zaebst DD, Clapp DE, Blade LM, Marlow DA, Steenland K, Hornung RW, Schuetzle D, Butler J [1991]. Quantitative determination of trucking industry workers' exposures to diesel exhaust particles. *Am Ind Hyg Assoc J* 52:529-541.

Zang X, McMurry PH [1992]. Evaporative losses of fine particulate nitrates during sampling. *Atmos Environ* 26A:3305-3312.

ZH 1/120.44, Verfahren zur Bestimmung von Kohlenstoff im Feinstaub - anwendbar für partikelförmige Dieselmotoremissionen in Arbeitsbereichen, Carl Heymanns Verlag, Cologne, 1995.



NIOSH Manual of Analytical Methods (NMAM), 5th Edition

Analysis of Carbon Nanotubes and Nanofibers on Mixed Cellulose Ester Filters by Transmission Electron Microscopy

by M. Eileen Birch, Chen Wang, Joseph E. Fernback, H. Amy Feng, Quinn T. Birch, and Alan K. Dozier, NIOSH

| | | |
|---|----------------------------------|-------|
| 1 | Introduction | CN- 2 |
| 2 | Sample Preparation | CN- 2 |
| 3 | TEM Analysis and Counting Method | CN- 6 |
| 4 | Conclusions | CN-18 |
| 5 | References | CN-18 |



Centers for Disease Control
and Prevention
National Institute for Occupational
Safety and Health



1 Introduction

A transmission electron microscopy (TEM) method for the analysis of filter samples of carbon nanotubes and nanofibers (CNT and CNF) is described in this Chapter. The approach is a modification to NIOSH NMAM 7402, asbestos by TEM [NIOSH 1994], and was applied to personal breathing zone (PBZ) and area samples collected at CNT/CNF survey sites [Birch et al. 2011; Dahm et al. 2015]. Procedures specific to asbestos fiber identification and counting were eliminated from 7402. In contrast to asbestos, CNT materials used commercially are typically in the form of complex agglomerates, with highly entangled, curved tubes. This curvature can sometimes make even individual fibers difficult to size. As such, a modified method that considers these structural differences was needed for particle classification.

TEM provides visualization of airborne CNT and CNF particles, indicating their size, shape, and agglomeration state [Birch et al. 2016]. These materials have distinct features (e.g., graphene layers, cylindrical structures, and hollow cores) that distinguish them from other types of particles. Given the considerable differences between CNT/CNF particles and asbestos fibers, particle counting methods necessarily differ. In the case of CNT/CNF, all particles, agglomerates as well as single fibers, are counted as a CNT/CNF 'structure.' Unlike Method 7402, no minimum size cutoffs have been used to date because of a lack of knowledge on lung deposition and toxicological endpoints.

Based on the number of CNT/CNF structures counted, and the collected air volume, a CNT/CNF concentration (i.e., structures/cm³) can be calculated. For samples collected at the survey sites, a significant positive correlation between structure counts and elemental carbon (EC) data was found, but there was considerable scatter in the data [Dahm et al. 2013, Dahm et al. 2015]. Given the method limitations discussed herein, the calculated values for structure counts are considered semi-quantitative indicators of air concentration.

2 Sample preparation

For the field surveys on CNT/CNF, open-face, 25-mm, three-piece cassettes were used for air sampling, approximating the inhalable fraction [Dahm et al. 2013, Dahm et al. 2015]. As specified in NMAM 7402, air samples were collected on mixed cellulose ester (MCE) filters having a nominal pore size of 0.8 μm (7402 specifies 0.45 to 1.2 μm), with sampling pumps operated at 5 L/min (0.5 to 16 L/min specified in 7402). Polycarbonate (PC) membrane filters also may be acceptable, but this media was not used in the field studies, and the filter preparation method differs from that described herein.



The sampling period depends on the air concentration, and it is important to avoid filter overload. Some trial and error may be necessary. In general, if a filter deposit is clearly visible, the sample is likely overloaded. An estimate of structure counts may still be possible, but overloading results in particle deposition on previously deposited material and may preclude an accurate structure count.

Three TEM grids per field sample, and one grid each for field and media blanks (when provided), were prepared using procedures outlined in NMAM 7402, with the following modifications:

- A scalpel is used to remove a wedge-shaped portion from the filter. Do not use a cork borer to remove filter sections.
- Only one sample wedge should be placed on each slide. Do not affix the section to the slide with any type of adhesive, as specified in 7402. (Note: After carbon coating the wedge and removing small portions for transfer to TEM grids, the remaining portion can be secured [e.g., with tape] to the slide for long term storage, if desired.)
- The “hot block” technique [Baron and Pickford 1986] is used to clear (collapse) the filter wedge. Other methods also may be suitable.

A description of the procedures used for sample and grid preparation is provided in the following three sections.

a. Filter

Carefully open the sampling cassette with a cassette opener, with the particle collection side facing upwards (Figure 1, step 1). Remove about one fourth of the 25-mm MCE filter with a clean scalpel. Place the wedge, particle side up, on a frosted glass microscope slide labelled with the sequence and sample numbers (Figure 1, step 2). Include a media (filter) blank with each set of slides to be coated. Use the “hot block” technique [Baron and Pickford 1986] to clear (collapse) the filter wedge (Figure 1, step 3). After clearing the filter, place the slides in a carbon coater to apply a thin carbon film (Figure 1, step 4); the filter surface should be evenly coated. After coating the filter wedges, the samples are ready for transfer to TEM grids. A Jaffe wick washer [Jaffe 1948] is used for final processing of the sample grids. Preparation of the washer and transfer of the sample sections to grids therein, for final processing, are described in the next two sections.

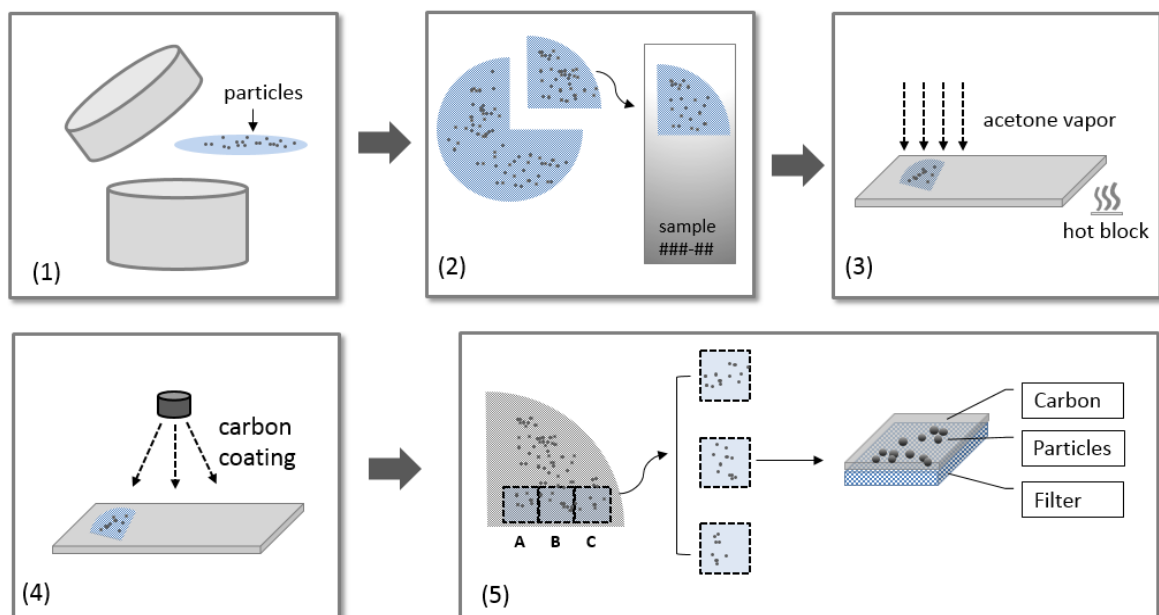

Figure 1. Filter preparation steps prior to loading sample portions on TEM grids: (1) remove 25-mm MCE filter from air sampling cassette; (2) remove about one fourth of the filter and place the filter wedge on a glass slide; (3) clear the MCE filter with acetone vapor in a hot block; (4) apply carbon coating; (5) cut section from coated filter and divide into three portions, one per grid. Each filter portion has particles sandwiched between the carbon film and collapsed filter.

b. Jaffe Wick washer

Prepare a Jaffe wick washer using a petri dish (15-mm depth recommended, but other sizes may be suitable), stainless steel screen (20 mesh), and lens tissue (Figure 2, a) or a stainless steel screen disk (40 mesh) (Figure 2, b) as a wicking substrate (one disk per sample). Bend two edges of the 20-mesh screen to form a platform (Figure 2) that fits inside the petri dish and is no higher than half the dish height. The platform supports the tissue (Figure 2, a) or stainless disk (Figure 2, b) onto which the sample grids are placed and keeps them above the solvent level during sample processing (Figure 2).

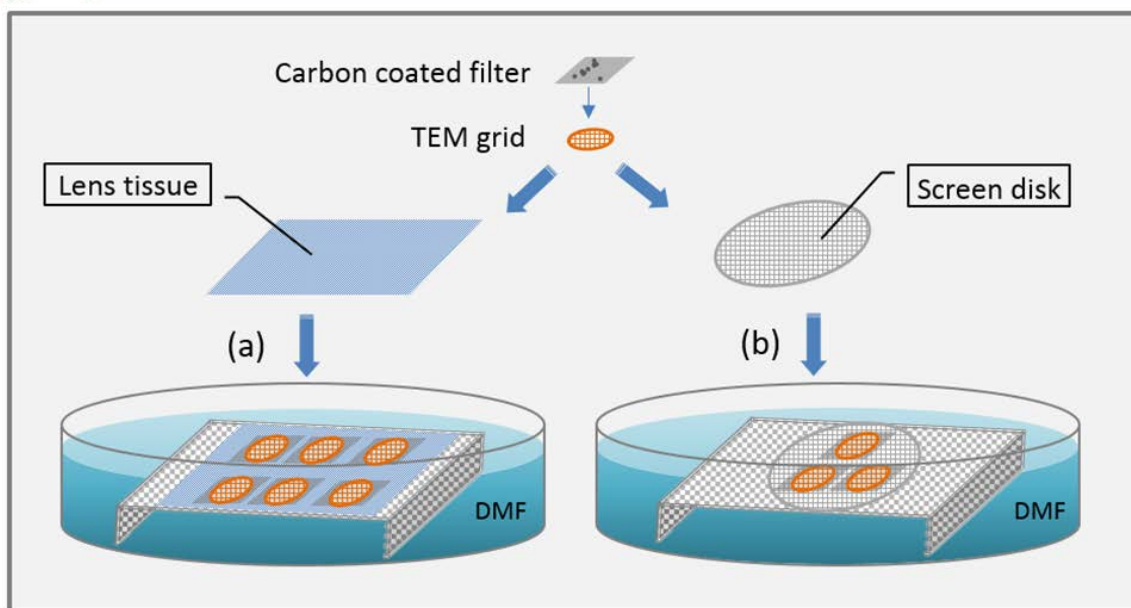

Figure 2. Sample transfer and final processing: place a piece of lens tissue (a) or a stainless steel screen disk (b) on a stainless screen platform in a Jaffe wick washer filled with dimethylformamide (DMF). Sides of the platform are bent to keep sample grids above the solvent level. Depending on size, multiple disks can be used to hold grids.

Use a pencil to label the lens tissue with the sample identifiers and place the tissue on the 20-mesh screen platform (Figure 2, a). The samples placed on the tissue should be the same set that was coated (together) in the carbon coater. Place the petri dish in a fume hood and carefully add dimethylformamide (DMF) to the dish until the lens tissue is saturated or screen disks are wetted, but ensure that no puddles form on surfaces of the tissue or disk. A combination of DMF and acetone also may be used for filter dissolution. (Note!: DMF [CAS 68-12-2] is flammable and hazardous in case of skin contact, eye contact, ingestion, and inhalation. Ensure adequate ventilation, proper personal protective equipment, and engineering controls in handling and storage. Consult SDS prior to use.) In a row, place three TEM grids per sample in the designated areas of the tissue or on a disk (Figure 2). If screen disks are used, place three TEM grids per sample on each (Figure 2, b). Depending on disk size, multiple disks can be used. Use one TEM grid each for the blanks (field and media).

c. Sample transfer and final processing

Using a scalpel and tweezers, cut and remove three small sections of the coated filter wedge as shown in Figure 1, step 5, starting at the center area (bottom left of wedge) of the filter and moving outward, across the bottom, towards the filter edge. The area of the cut sections should be similar and enough to cover a grid. Carbon side up, carefully place the excised filter sections on the three grids. If lens tissue is used,

place the section from the center of the filter (Figure 1, Step 5, A) on the leftmost grid, the middle section (Figure 1, Step 5, B) on the center grid, and the outermost section (Figure 1, Step 5, C) on the rightmost grid. The locations are labeled as shown in Figure 1, step 5. When all filter sections have been transferred to the grids, slowly add more solvent to raise the level as high as possible without disturbing the sample preparations. Cover the petri dish, if lens tissue is used, and elevate one side of the dish by placing a microscope slide under it (allowing drops of condensed solvent to form near the edge of the cover rather than in the center, where they can drip on the grid preparation). To dissolve the filter, the tissue method requires the grids to sit overnight, while the screen disk method requires only about 30 minutes. If screen disks are used, leave the petri dish uncovered, in a fume hood or other well ventilated area. Once the residual MCE polymer is completely dissolved in the solvent, only particles embedded in the carbon film remain on the grid, as illustrated in Figure 3. Ensure that the processed grids are solvent free prior to the TEM analysis.

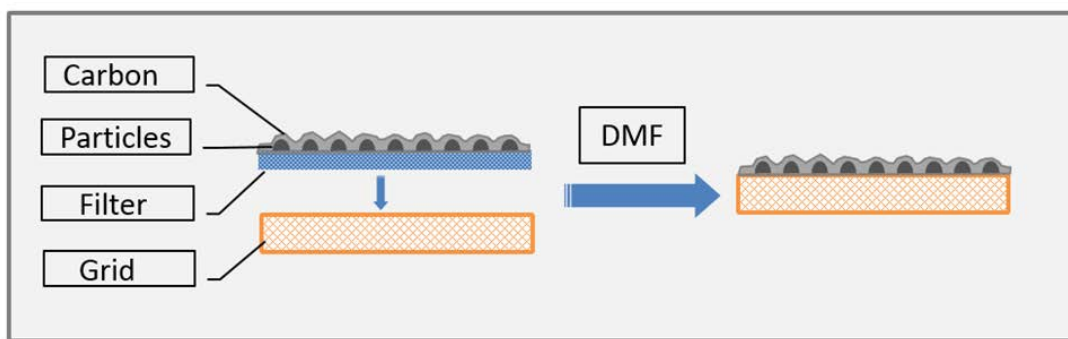

Figure 3. Removal of residual MCE polymer from carbon-coated sample by dimethylformamide (DMF). After polymer removal, only particles embedded in the carbon film remain on the grid.

3. TEM analysis and counting method

a. Sample quality

Align the microscope for TEM applications following the manufacturer's instructions. Load the sample into a TEM grid holder and insert the holder into the TEM column. First, examine the grid at low magnification (500-1,000X) to determine the filter loading and preparation quality. In general, to be acceptable for analysis, the grid should have at least 75% intact grid openings and a particle loading less than about 25% (area coverage).

If these criteria are met, randomly select at least four openings (with intact carbon film) from four quadrants of the grid and estimate the number of particles per opening to determine the distribution variability. If the particle loading is uneven or heavy, the sample might not be useful. Discuss any uneven distributions or loading issues with the requestor of the analysis.

b. Definition of a CNT/CNF structure

Count all particles that meet the following definition of a CNT structure:

- Any CNT or CNF individual fiber (Figure 4) with an aspect ratio (i.e., length to width) greater than 3:1. There are no minimum length or diameter cutoffs. If a fiber structure has the morphological characteristics of CNT/CNF and meets the 3:1 aspect ratio criterion, it is counted. In our work, isolated CNT fiber or bundle structures were relatively rare. CNT agglomerates were far more common.

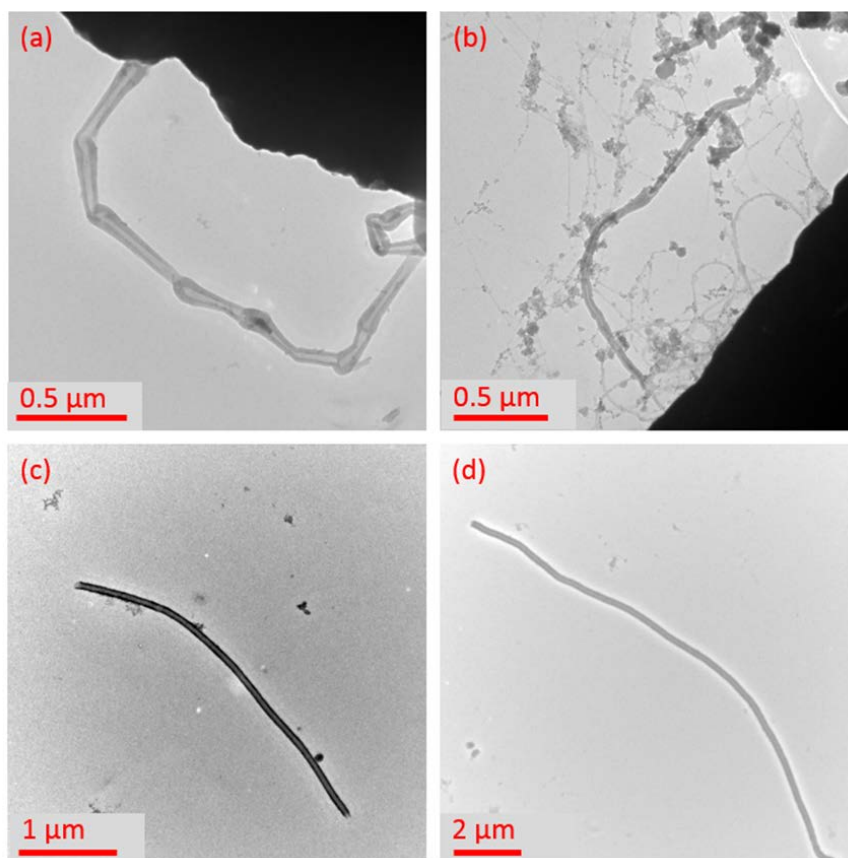

Figure 4. Examples of CNT fiber structures with various lengths and widths.

- Any particle agglomerate with associated CNT/CNF: There are many types of structures that fit this criterion. Some structures, classified as matrix particles, contain relatively few CNT/CNF, being mainly amorphous carbon or other components. In contrast, structures that consist mainly of CNT/CNF are classified as cluster particles.

In this chapter, ‘agglomerate’ refers to both cluster (Figure 5) and matrix (Figure 6) particles. Although matrix particles have associated CNT, they are often observed as fiber structures protruding from the particle edge. The structure of the CNT, presumably within the matrix, cannot be determined in the TEM analysis. Another classification problem occurs when agglomerates have cluster and matrix regions (Figure 7) of similar size. Structure counts are discussed in the next section.

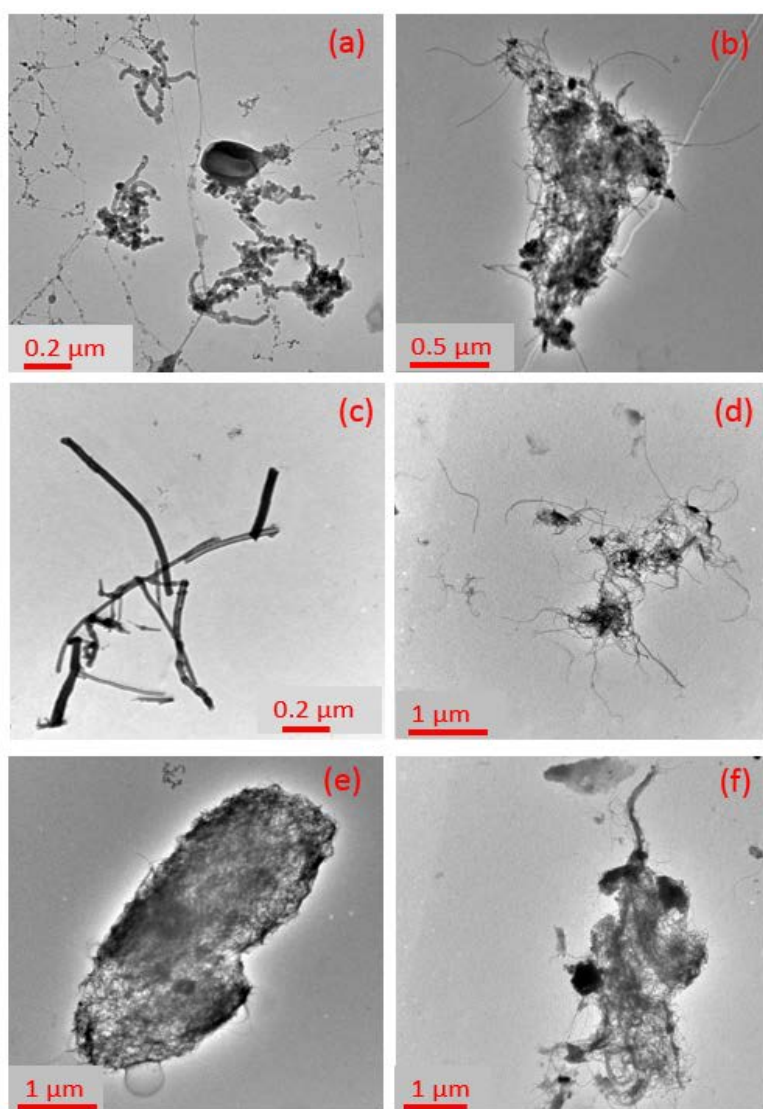

Figure 5. Examples of CNT/CNF clusters: (a)-(f) collected from workplaces.

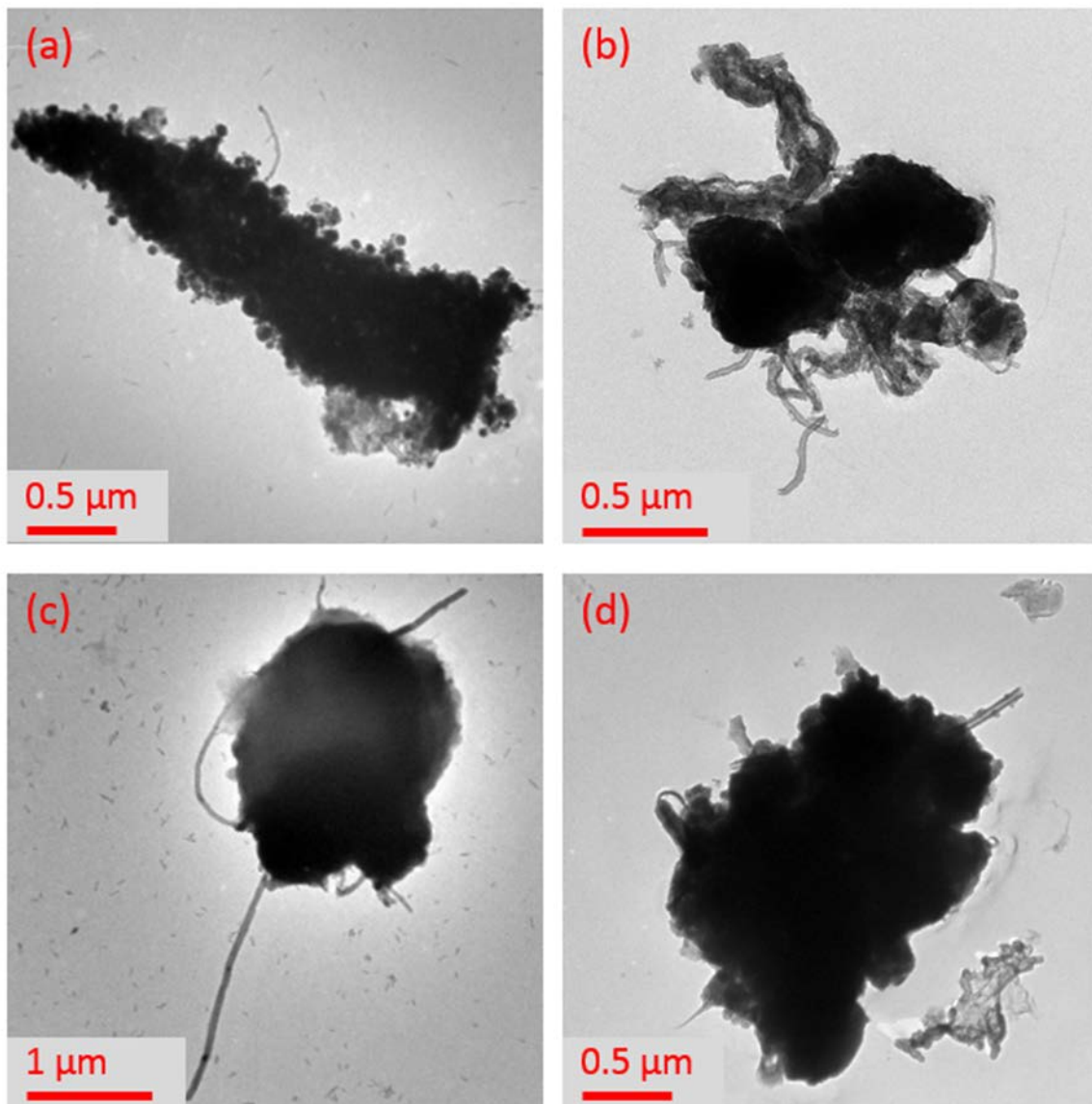
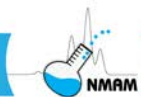

Figure 6. Examples of CNT matrix particles: (a)-(d) collected from workplaces.

There are specific definitions of CNT and CNF; however, field samples have contained complex mixtures of structures that often do not fit these narrow definitions. For example, products described as CNT can contain CNF and vice versa, and a variety of irregularly shaped, nanoscale carbon particles have been observed. In practice, if the analytical request specifies a 'CNT' or 'CNF' facility, these terms are used in the analytical report, along with the corresponding TEM images. In addition, images and information on other types of particles are provided.



c. Structure counts

The counting method for individual fibrous structures generally follows that for asbestos, as in NMAM 7402 and EPA's AHERA (Asbestos Hazard Emergency Response Act) method [40 CFR 763; NIOSH 1994]. That is, each fiber with an aspect ratio $> 3:1$ is counted and the diameter and length are recorded. At a minimum, the diameter and length ranges are recorded, and averages are determined, if appropriate. This procedure is negotiable with the requestor.

As mentioned, in the field samples, isolated CNT fibers were rare relative to particle agglomerates. The classification of CNT/CNF agglomerates is accomplished by considering both particle size and structure. The size bin depends on the maximum crosswise dimension. At least one dimension, the maximum crosswise length, is recorded for each structure. Other characteristics also can be examined to meet investigator needs. Some agglomerates, especially larger ones, may contain a non-CNT/CNF component. In these instances, if the agglomerate looks to be mostly CNT/CNF, it is classified as a cluster. If non-CNT/CNF components appear more abundant, the matrix classification is used. However, as discussed, some agglomerates may have roughly equal cluster and matrix portions. For these, a matrix category is usually assigned but this classification is somewhat arbitrary. Given the difficulties of particle classification, it is important to provide representative images of all particles in the sample.

If the particle loading and distribution are acceptable, an initial particle count can be performed at low magnification. Select the lowest magnification that shows the majority of the particulate of interest: 5,000-15,000X is usually sufficient. Smaller particles may not be visible at low magnification, but the purpose of this step is to assess the number of grid openings likely to be counted. If the sample composition is known (e.g., a laboratory generated CNT or CNF sample), an initial count can be made to count larger (micrometer sized) CNT (CNF) particles, which dominate the particle mass. After examination of the sample at low magnification, a switch to high magnification (e.g., 40,000X) is made to image particles/features not observable at low magnification. The magnification should be adjusted as required for counting and confirming the presence of CNT.

As discussed, for the analysis, three 3-mm copper TEM grids are usually prepared from each sample. A total of 40 openings (stop counting at 100 structures) are examined at high magnification (13-15 openings for each grid). The number of grid openings counted per grid should be approximately equal for the three grid preparations, and the openings counted on each grid should be selected as randomly as possible. Only grid openings that have the carbon film intact should be counted.

Any particles containing CNT/CNF are counted as CNT or CNF structures, which can range from single fibers (Figure 4) to structures of varying size and composition (Figs. 5-9). Counted CNT/CNF structures are categorized by size-bins based on the

maximum crosswise dimension. In our studies [Dahm et al. 2015; Birch et al. 2016], most of the CNT agglomerates had a roughly spherical shape (i.e., the longest dimension was no more than twice the length of the orthogonal dimension). Therefore, the maximum crosswise dimension was used to categorize structure size. The counted structures were placed into five discrete size-bins, based on health-relevant size fractions and observations from field studies [Birch 2011; Dahm et al. 2013]. The structure categories also included a separate bin for single fibers. Size bins for the CNT/CNF structures have the following maximum crosswise dimensions: $< 1 \mu\text{m}$, $1\text{-}2 \mu\text{m}$, $2\text{-}5 \mu\text{m}$, $5\text{-}10 \mu\text{m}$, and $> 10 \mu\text{m}$. This sizing scheme was used to analyze CNT/CNF samples collected during field surveys [Dahm et al. 2015]. A statistical analysis of the TEM counts for a subset of the field samples is provided in the following section.

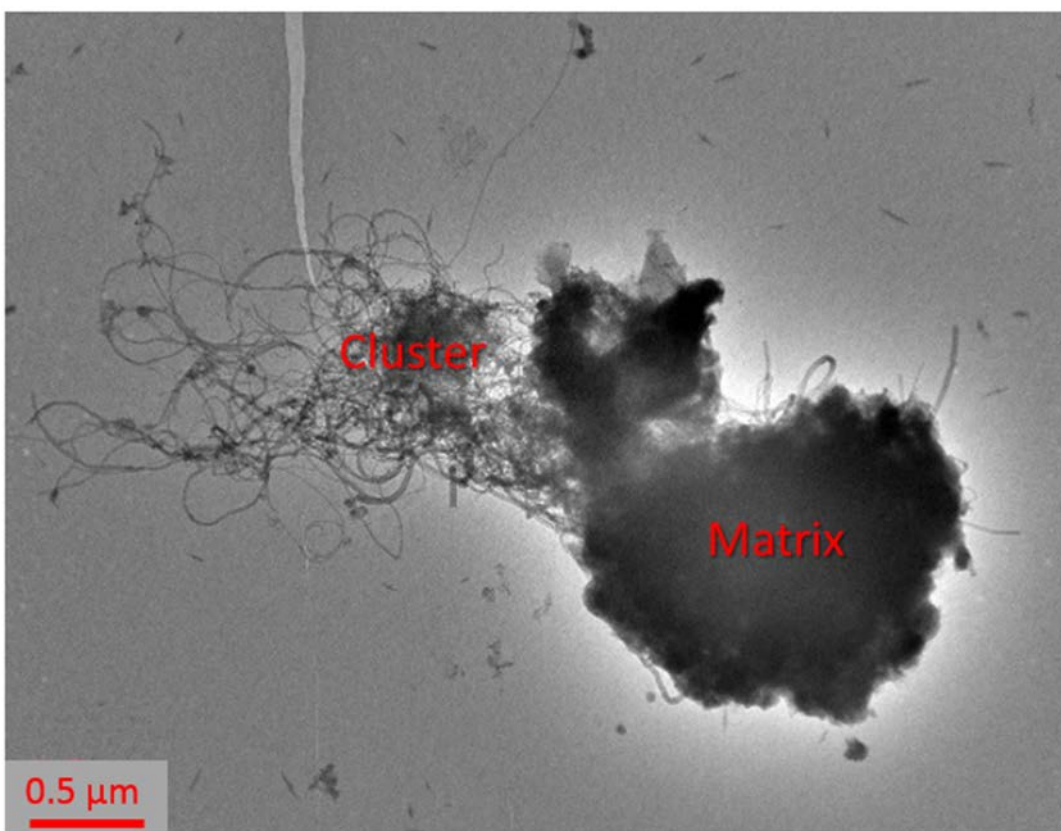

Figure 7. CNT particle with both matrix (right side) and cluster (left) features. Structure categorized as a CNT matrix particle.

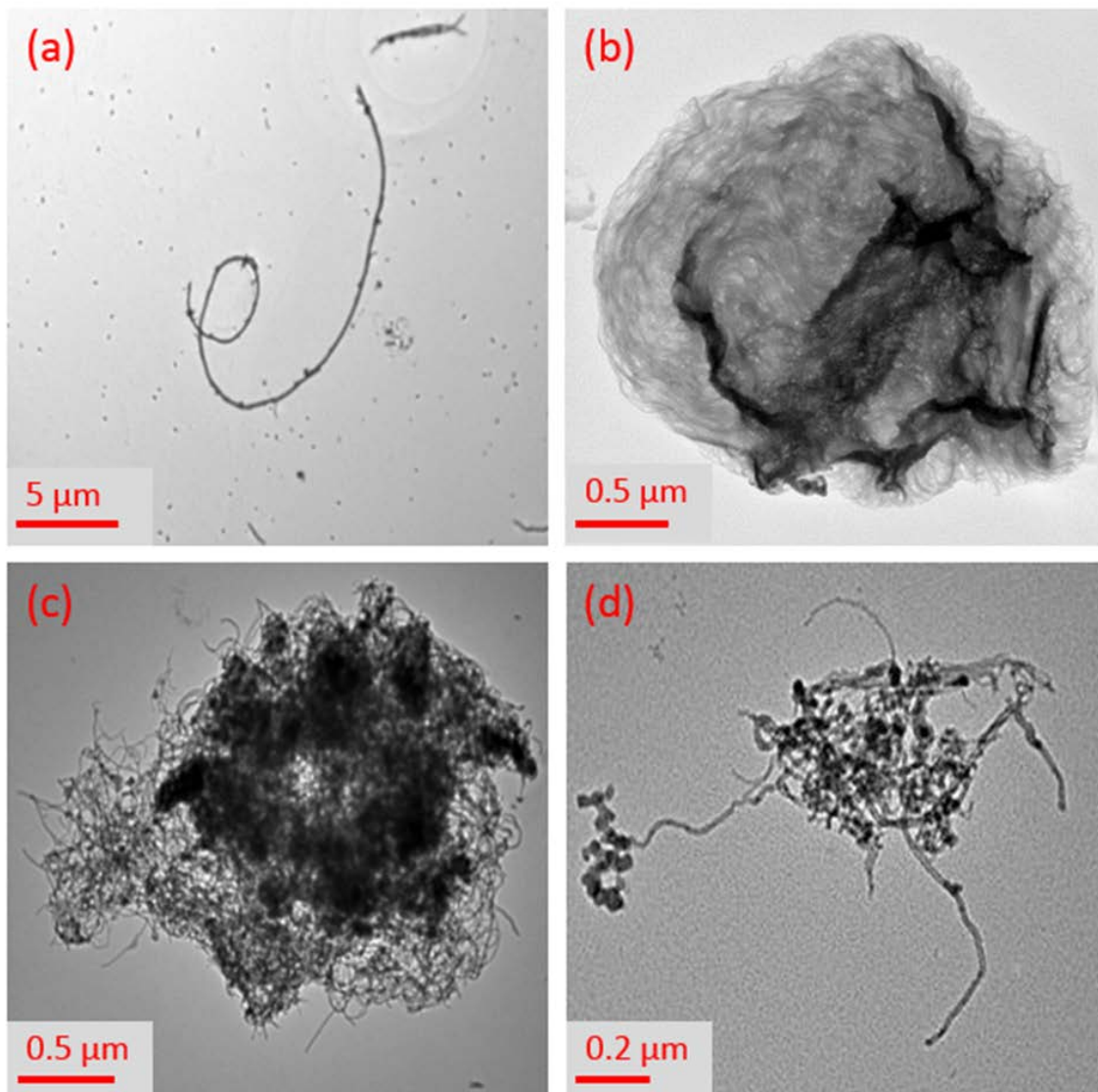

Figure 8. CNT particles in personal breathing zone samples collected from various sites: (a) MWCNT fiber (polymer composite site), b) SWCNT agglomerate from aerosolized, aqueous suspension (electronics site), c) MWCNT agglomerate (composites/thermoplastics site), and d) MWCNT agglomerate (primary manufacturer of CNT).

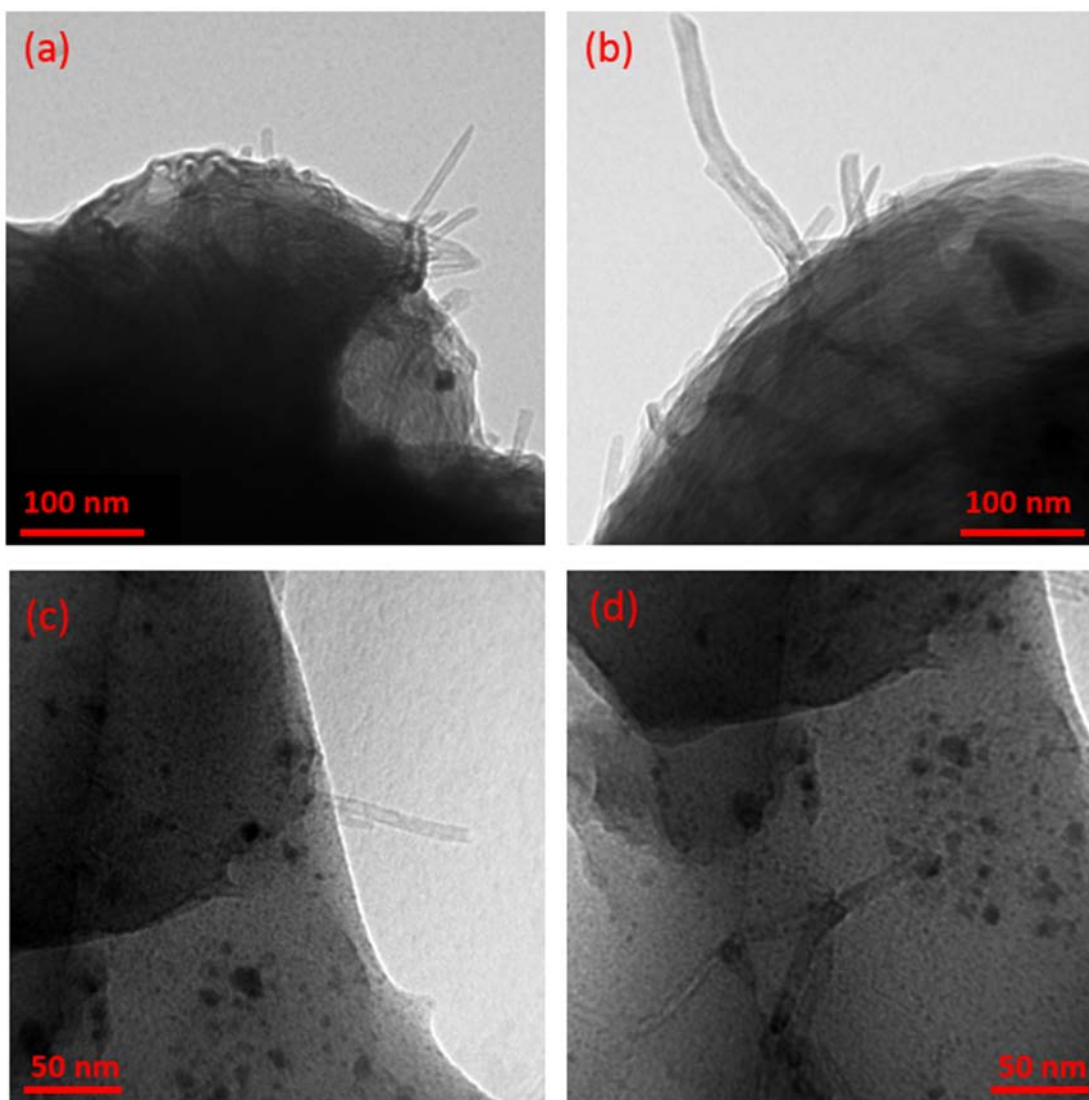

Figure 9. Examples of CNT particles embedded in polymer composite: (a)-(d).

d. Statistics

A total of 3000 observations (structures/opening) from 75 field samples with light loading (<5 structures per grid opening) were analyzed. The mean, standard deviation, and confidence intervals (95% confidence level) were calculated. Factors considered included grid (1-3), opening (1-14), and loading level (1-3). Grids were counted in the order of grid 1, 2, and then 3, going from the center to the edge of the filter (wedge portion). From Figure 10 and Table 1, the means and variabilities of counts from different loading levels follow the same trend. The variability of grid 1 (from center area of filter) was slightly higher than the other 2 grids. The variability becomes smaller when the loading level is increased. The box plot in Figure 11 shows the statistics of counts by openings. The means and variabilities of counts from opening 1 and 2 were slightly higher than counts from opening 12, 13 and 14. Because opening 1 was the first opening counted, and 14 the last, it is possible that

the increased variability is due to higher analyst error during the initial and final counts. The test of half data (including openings 1-7) shows similar behavior as that for all data (Figure 12). Based on the results for this sample set, counts from one or two grids, with 7 openings per grid, may be adequate if the deposit is even. Larger data sets from samples with different loadings and collected from various sites are required to develop a statistical model for further analysis.

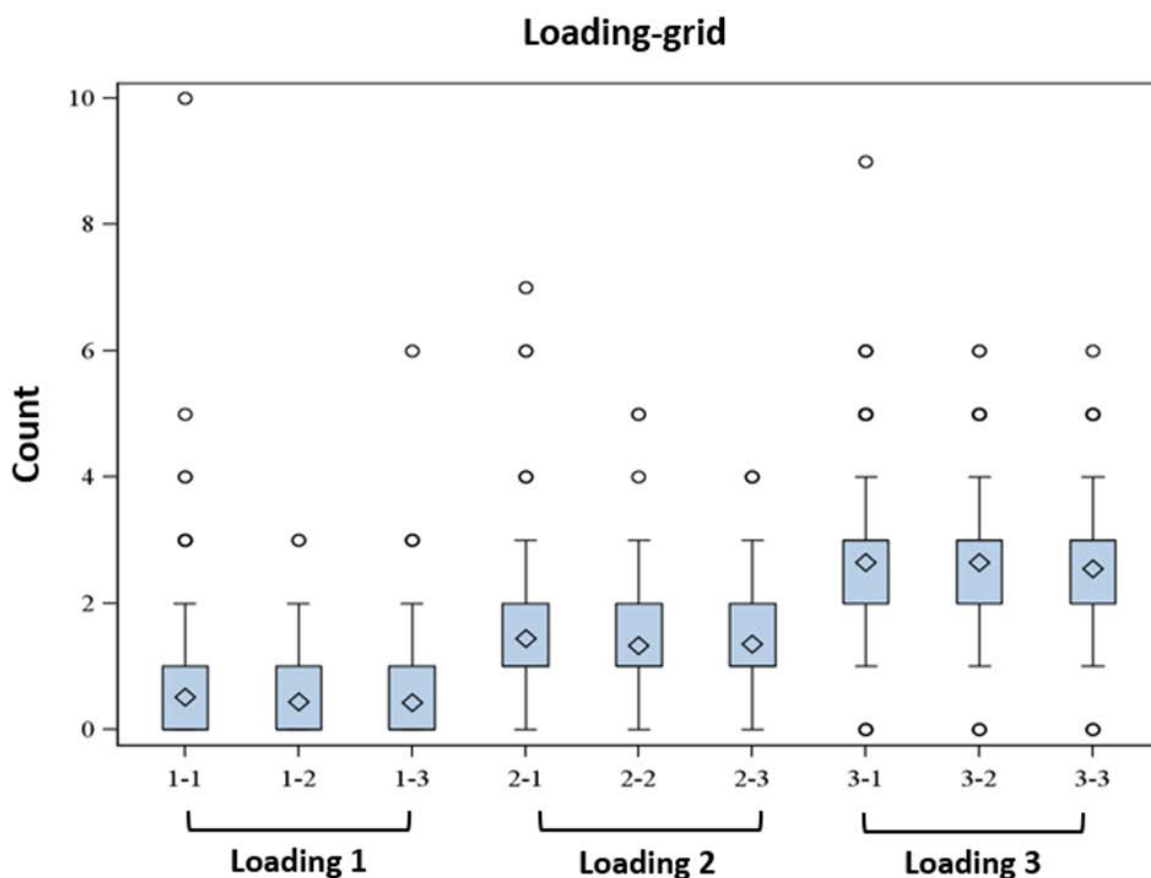

Figure 10. Boxplot of CNT counts by categorized loading (1: mean ≤ 1 , 2: $1 < \text{mean} \leq 2$, and 3: mean > 2) from three grids. The trend of mean counts from grid 1 to 3 is consistent for different loading levels. Mean count of grid 1 is slightly higher than those of grid 2 and 3.

Table 1. Statistics of sample counts obtained from different grids and loading levels (*M*=Mean, *SD*=Standard Deviation, *CI*=Confidence Intervals).

| Loading ^a | Grid 1 ^b | | Grid 2 ^b | | Grid 3 ^b | |
|----------------------|------------------------|---------------|------------------------|---------------|------------------------|---------------|
| | <i>M</i> (<i>SD</i>) | 95% <i>CI</i> | <i>M</i> (<i>SD</i>) | 95% <i>CI</i> | <i>M</i> (<i>SD</i>) | 95% <i>CI</i> |
| Level 1 | 0.51 (0.84) | [0.44, 0.58] | 0.44 (0.64) | [0.38, 0.49] | 0.43 (0.66) | [0.37, 0.49] |
| Level 2 | 1.45 (1.12) | [1.29, 1.60] | 1.33 (0.91) | [1.21, 1.46] | 1.35 (0.90) | [1.23, 1.48] |
| Level 3 | 2.65 (1.32) | [2.50, 2.80] | 2.64 (1.10) | [2.51, 2.77] | 2.55 (1.07) | [2.43, 2.68] |
| All | 1.33 (1.41) | [1.24, 1.41] | 1.26 (1.28) | [1.18, 1.34] | 1.24 (1.25) | [1.16, 1.32] |

^a Loading levels are defined by *M*, where Level 1 ($M \leq 1$), Level 2 ($1 < M \leq 2$) and Level 3 ($M > 2$).

^b Grids collected from different locations on a filter wedge (center to edge).

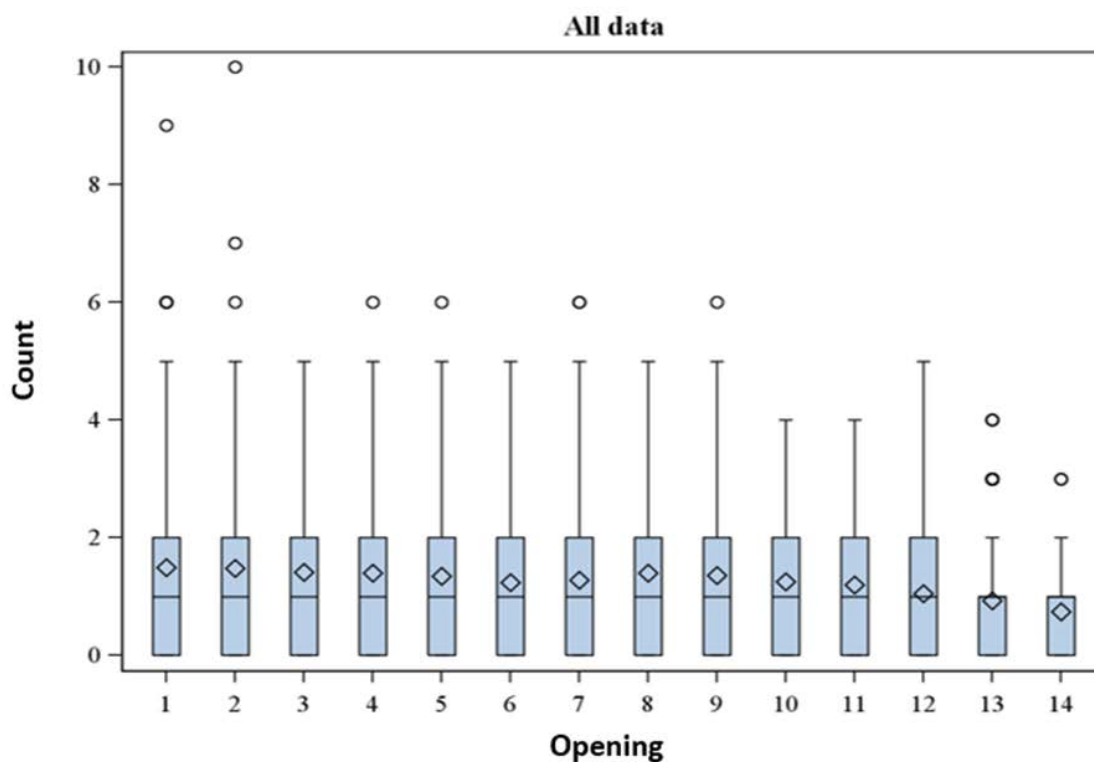

Figure 11. Boxplot of CNT counts by openings (1-14). The variability in openings 1 and 2 significantly higher than that of openings 13 and 14. The means of openings 1, 2 and 3 were also higher than the means of openings 12, 13, and 14.

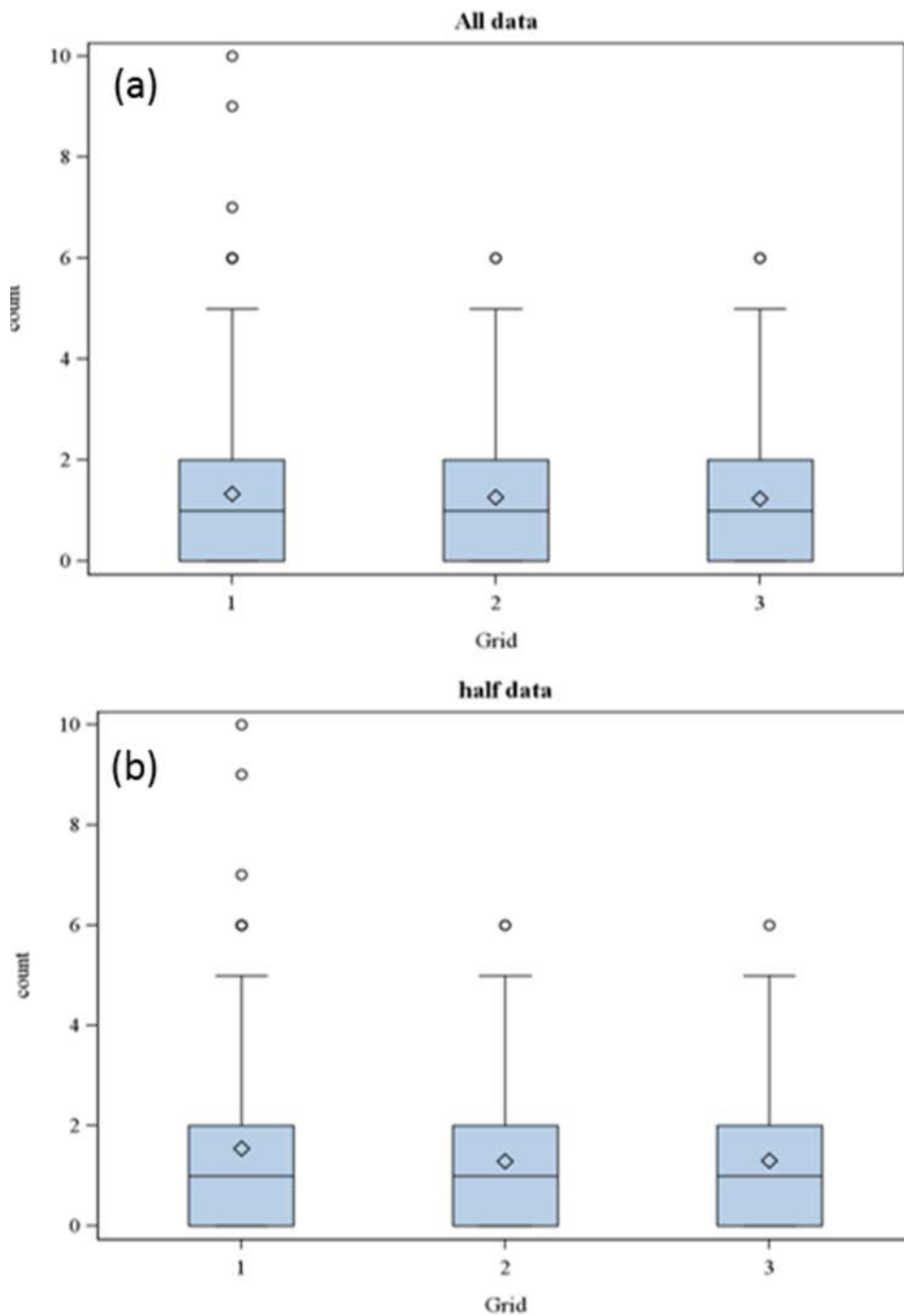

Figure 12. Boxplot of CNT counts by grids (1-3) from all data (counts from openings 1-14) and half data (counts from openings 1-7).



e. Limit of detection (LOD)

For the field samples [Dahm et al. 2015], the ‘no structures detected’ TEM samples were those with counts below the LOD, defined as 1 CNT or CNF structure per sample. The corresponding unit of structures per cm^3 LOD (air concentration) was then calculated (by the requestor) based on the total air volume sampled.

f. CNT/CNF polymer composites

Dusts generated from CNT/CNF polymer composites that have been mechanically worked (e.g., drilled, cut, sanded, blasted, etc.) contain particles with CNT/CNF embedded in the polymer matrix. Our analyses of polymer composite dusts have shown little evidence of individual fiber release from the composite matrix, but respirable sized matrix particles with protruding CNT/CNF have been observed (Figure 9). These findings are consistent with other reports [Bello et al. 2012; Kingston et al. 2014] on potential CNT/CNF release from polymer matrices. Particle counts for these types of samples also can be performed, though only a limited number of surveys have been conducted. Because the CNT/CNF are embedded in a polymer matrix, the toxicity of these dusts may differ substantially from dusts with free (unbound) agglomerates. Nevertheless, representative images of the particles and information on particle shape and size can be documented.

g. Limitations

The composition of CNT powders varies substantially, especially those produced or used in workplaces. These materials contain varying amounts of amorphous carbon and residual catalyst metals, and there are many types of structures, usually in agglomerate form. As mentioned, in the case of composite dusts, CNT are embedded in a polymer matrix, which complicates their measurement. This chapter concerns the analysis of CNT powders.

In the case of ‘matrix’ particles, TEM images show mainly dark regions, with varying amounts of CNT observed at the particle’s edge. The composition of material in the dark regions is unknown. For example, it may be mainly CNT, amorphous carbon, or a combination of both. Thus, based on overall envelope size, a particle consisting mainly of amorphous carbon is counted in the same bin as an agglomerate composed mainly of CNT. Both matrix and cluster (structures with mainly CNT) type particles were common in field samples. A different counting method [Chen et al. 2012] was applied to a specific type of MWCNT (Mitsui MWCNT-7) used in an animal inhalation study but this particular product, having a more fibrous structure and more single fibers, differs from the CNT materials manufactured/used by U.S. companies. Images (Figs. 4-9) of the different particle types found in our field surveys make obvious the difficulty in developing a standardized TEM structure count method for these materials.



4. Conclusions

The complexity and variety of structures makes CNT/CNF particle counting a challenge. Unlike elemental carbon or other less selective measures, TEM can confirm the presence of CNT. However, with respect to quantification, it is important to recognize the limitations of a counting method. Because of the heterogeneity of CNT powders, particles in the same size bin can vary greatly in their properties. Complex structures of varying mass, density, shape, and composition (e.g., amorphous carbon, residual catalyst) can fall into the same size bin. And dissimilar particles (e.g., cluster and matrix) in a given bin may have different toxicological effects. Thus, even for a given material, particle envelope size alone may not be an adequate risk indicator. Given the heterogeneity and variety of the CNT/CNF products to which workers are exposed, it is important to apply several methods to assess worker exposure, through inhalation and other routes.

Disclaimer

Mention of any company or product does not constitute endorsement by NIOSH. In addition, citations to websites external to NIOSH do not constitute NIOSH endorsement of the sponsoring organizations or their programs or products. Furthermore, NIOSH is not responsible for the content of these websites. All web addresses referenced in this document were accessible as of the publication date.

5. References

Baron PA, Pickford GC[1986]. An Asbestos Sample Filter Clearing Procedure. *Appl Ind Hyg* 1(4):169-171.

Bello D, Wardle BL, Yamamoto N, deVilloria RG, Hallock M[2011]. Exposures to nanoscale particles and fibers during handling, processing, and machining of nanocomposites and nanoengineered composites reinforced with aligned carbon nanotubes. Proceedings of the 17th International conference on composite materials (ICCM), Edinburgh, Scotland, July 27–31, 2011.

Birch ME [2011]. Exposure and emissions monitoring during carbon nanofiber production—Part II: Polycyclic Aromatic Hydrocarbons. *Ann Occup Hyg* 55(9):1037-1047.

Birch ME, Ruda-Eberenz TA, Chai M, Andrews R, Hatfield RL [2013]. Properties that Influence the Specific Surface Areas of Carbon Nanotubes and Nanofibers. *Ann Occup Hyg* 57(9):1148-1166.

Birch ME, Wang C, Fernback JE, Feng HA, Birch QT, Dozier AK [2016]. Workplace Monitoring of Airborne Carbon Nanomaterials by HRTEM. *Microsc Microanal* 22(S3): 1910-1911.



Chen BT, Schwegler-Berry D, McKinney W, Stone S, Cumpston JL, Friend S, Porter DW, Castranova V, Frazer DG [2012]. Multi-walled Carbon Nanotubes: Sampling Criteria and Aerosol Characterization. *Inhalation Toxicology* 24(12):798-820.

CFR. Code of Federal Regulations. Washington, DC: U.S. Government Printing Office, Office of the Federal Register.

Dahm MM, Evans DE, Schubauer-Berigan MK, Birch ME, Fernback JE [2012]. Occupational Exposure Assessment in Carbon Nanotube and Nanofiber Primary and Secondary Manufacturers. *Ann Occup Hyg* 56(5):542-556.

Dahm MM, Evans DE, Schubauer-Berigan MK, Birch ME, Deddens JA [2013]. Occupational Exposure Assessment in Carbon Nanotube and Nanofiber Primary and Secondary Manufacturers: Mobile Direct-Reading Sampling. *Ann Occup Hyg* 57(3):328-344.

Dahm MM, Schubauer-Berigan MK, Evans DE, Birch ME, Fernback JE, Deddens JA [2015]. Carbon Nanotube and Nanofiber Exposure Assessments: An Analysis of 14 Site Visits. *Ann Occup Hyg* 59(6):705-723.

Jaffe MS [1948]. Handling and washing of fragile replicas. *J. Appl. Physics* 19:1189-1191.

Kingston C, Zepp R, Andrady A, Boverhofd D, Fehire R, Hawkins D, Roberts J, Sayreg P, Shelton B, Sultani Y, Vejinsj V, Wohlleben W [2014]. Release Characteristics of Selected Carbon Nanotube Polymer Composites. *Carbon* 68:33-57.

NIOSH [1994]. Method 7402 asbestos by TEM. In: Eller PM, Cassinelli ME, eds. *NIOSH Manual of Analytical Methods*. 4th ed. Cincinnati, OH: U.S. Department of Health and Human Services, Centers for Disease Control and Prevention, National Institute for Occupational Safety and Health, DHHS (NIOSH) Publication No. 94-113 [www.cdc.gov/niosh/nmam/].



NIOSH Manual of Analytical Methods (NMAM), 5th Edition

Glossary of Abbreviations, Definitions and Symbols

Compiled by Kevin Ashley, Ph.D., NIOSH

| | |
|---|--------|
| A | GL-2 |
| B | GL-4 |
| C | GL-7 |
| D | GL-9 |
| E | GL-12 |
| F | GL-13 |
| G | GL-13 |
| H | GL-14 |
| I | GL-14 |
| L | GL-15 |
| M | GL-16 |
| N | GL-17 |
| O | GL-17 |
| P | GL-18 |
| Q | GL-20 |
| R | GL-20 |
| S | GL-21 |
| T | GL-23 |
| U | GL- 24 |
| V | GL-25 |
| W | GL- 26 |
| X | GL- 26 |



**Centers for Disease Control
and Prevention**
National Institute for Occupational
Safety and Health



Terms & Definitions

A

AAS - Atomic absorption spectrometry

Absorption Barrier - Any exposure surface that may retard the rate of penetration of an agent into a target. Examples of absorption barriers are the skin, respiratory tract lining, and gastrointestinal tract wall (cf. exposure surface). [Source: Zartarian V, Bahadori T, McKone T [2005]: Adoption of an official ISEA glossary. *J Expo Anal Environ Epidemiol* 15:1–5.]

Acceptable Range (biological) - The range of values of a biological monitoring analyte that would be expected in workers with exposure to the chemical agent in the workplace at or below regulatory or recommended levels. These ranges are often method-specific. [Adapted from: NIOSH [1994]. *NIOSH Manual of analytical methods (NMAM)*, 4th ed. DHHS (NIOSH) Publication No. 94-113.]

Accuracy –

1. The degree of agreement between a measured value and the accepted reference value. In this manual, accuracy is calculated from the absolute mean bias of the method plus the overall precision, \hat{s}_{rT} at the 95% confidence level. For an individual measurement, it includes the combination of precision and bias [Source: NIOSH [1977]: Documentation of the NIOSH Validation Tests. DHEW (NIOSH) Publication No. 77-185.]
2. Measure of confidence in a measurement. It is a qualitative term referring to whether there is agreement between a measurement made on an object and its true (target or reference) value. [Source: NIST/SEMATECH e-Handbook of Statistical Methods; Gaithersburg, MD: National Institute of Standards and Technology, <http://www.itl.nist.gov/div898/handbook/>]
3. The ability of a method to determine the “true” concentration of the environment sampled. Accuracy describes the closeness of a typical measurement to the quantity measured although it is defined and expressed in terms of the relative discrepancy of a typical measurement from the quantity measured. The special sense of accuracy for a method is embodied in the following definition and criterion: The accuracy of a method is the theoretical maximum error of measurement, expressed as the proportion or percentage of the amount being measured without regard for the direction of the error that is achieved with 0.9 probability by the method. [Source: NIOSH [1995]: Guidelines for air sampling and analytical method development and



evaluation. By Kennedy ER, Fischbach TJ, Song R, Eller PM, Shulman SA. DHHS (NIOSH) Publication No. 95-117, <http://www.cdc.gov/niosh/docs/95-117/pdfs/95-117.pdf>.]

4. The degree of conformity of a value generated by a specific procedure to the assumed or accepted true value. It includes both precision and bias. [Source: ASTM [2014]. D1356, Standard terminology relating to sampling and analysis of atmospheres. West Conshohocken, PA: ASTM International]

ACGIH - American Conference of Governmental Industrial Hygienists

Acute Exposure - A contact between an agent and a target occurring over a short time, generally less than a day. Note: Other terms, such as “short-term exposure” and “single dose,” are also used. [Source: Zartarian V, Bahadori T, McKone T [2005]: Adoption of an official ISEA glossary. *J Expo Anal Environ Epidemiol* 15:1–5.]

Aerosol –

1. Airborne particles and the gas (and vapor) mixture in which they are suspended. Note: The airborne particles can be in or out of equilibrium with their own vapors. [Source: CEN [2011]. EN 1540, Workplace atmospheres – terminology. Brussels: European Standards Commission.]
2. Dispersion of solid or liquid particles in a gaseous medium. [Source: ASTM [2014]. D1356, Standard terminology relating to sampling and analysis of atmospheres. West Conshohocken, PA: ASTM International.]

Agent - A chemical, biological, or physical entity that contacts a target. [Source: Zartarian V, Bahadori T, McKone T [2005]: Adoption of an official ISEA glossary. *J Expo Anal Environ Epidemiol* 15:1–5.]

Analyte –

1. Substance or chemical constituent that is determined in an analytical method [Source: CEN [2011]. EN 1540, Workplace atmospheres – terminology. Brussels: European Standards Commission.]
2. A specific chemical moiety being measured, which can be intact drug, biomolecule or its derivative, metabolite, and/or degradation product in a biologic matrix. [Source: FDA [2001]. Guidance for industry - bioanalytical method validation, <http://www.fda.gov/downloads/Drugs/Guidances/ucm070107.pdf>.]

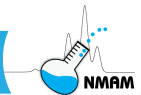

Ashing - The decomposition, prior to analysis, of organic matrix constituents of the sample and sampler. The most common ashing techniques are solvent, acid, or alkali dissolution; alkaline fusion; and oxidation using either low-temperature oxygen plasma or muffle furnace. [Source: NIOSH [1994]. NIOSH Manual of analytical methods (NMAM), 4th ed. DHHS (NIOSH) Publication No. 94-113.]

ASV - Anodic stripping voltammetry

Atmospheric Concentration - The quantity of a constituent substance per unit volume of air [Adapted from definition of 'concentration' in: ASTM [2014]. D1356, Standard terminology relating to sampling and analysis of atmospheres. West Conshohocken, PA: ASTM International.]

Atmospheric Deposition - The transfer of an atmospheric constituent to a surface due to gravity or another mechanism, or the material which is transferred [Adapted from definition of 'deposition' in: ASTM [2014]. D1356, Standard terminology relating to sampling and analysis of atmospheres. West Conshohocken, PA: ASTM International.]

Atmospheric Dispersion - The most general term for a system consisting of a constituent suspended in air [Adapted from definition of 'dispersion': ASTM [2014]. D1356, Standard terminology relating to sampling and analysis of atmospheres. West Conshohocken, PA: ASTM International.]

AW - Atomic weight

B

B - Media blank result for a single-section sampler (e.g., sorbent tube.)

B_b - Media blank result for back section of a sampler.

B_f - Media blank result for front section of a sampler.

Background Level - The amount of an agent in a medium (e.g., water, soil) that is not attributed to the source(s) under investigation in an exposure assessment. Background level(s) can be naturally occurring or the result of human activities. (Note: Natural background is the concentration of an agent in a medium that occurs naturally or is not the result of human activities.) [Source: Zartarian V, Bahadori T, McKone T [2005]: Adoption of an official ISEA glossary. *J Expo Anal Environ Epidemiol* 15:1-5.]



Bias –

1. A systematic (nonrandom) deviation of the method average value or the measured value from an accepted value. [Source: ASTM [2014]. D1356, Standard terminology relating to sampling and analysis of atmospheres. West Conshohocken, PA: ASTM International.]
2. Difference between the average measured mass or concentration and reference mass or concentration expressed as a fraction of reference mass or concentration. [Source: NIOSH [1994]. NIOSH Manual of analytical methods (NMAM), 4th ed. DHHS (NIOSH) Publication No. 94-113.]
3. An estimate of a systematic measurement error [Source: ISO [2015]. ISO 18158 Workplace air – terminology. Geneva: International Organization for Standardization.]

Bioaerosol - An aerosol consisting of (a) biological agent(s). Note: Airborne dusts of organic origin, for example, cotton dust, flour dust and wood dust, are not considered to be bioaerosols and are therefore not covered by this definition [Source: ISO [2015]. ISO 18158 Workplace air – terminology. Geneva: International Organization for Standardization.]

Bioavailability –

1. The rate and extent to which an agent can be absorbed by an organism and is available for metabolism or interaction with biologically significant receptors. Bioavailability involves both release from a medium (if present) and absorption by an organism. [Source: Zartarian V, Bahadori T, McKone T [2005]: Adoption of an official ISEA glossary. *J Expo Anal Environ Epidemiol* 15:1–5.]
2. The extent to which a chemical substance to which the body is exposed (by ingestion, inhalation, injection, or skin contact) reaches the systemic circulation, and the rate at which this occurs. It is recognized that the bioavailability (for gastrointestinal absorption) of, for example, both essential and non-essential metals, depends on various factors including the composition of the diet and the type of the chemical compound and its state of dispersion. For instance, the absorption of lead and cadmium is increased if the food is deficient in calcium or iron [Source: ILO/IPCS. Glossary of terms on chemical safety (after WHO, 1979), <http://www.ilo.org/legacy/english/protection/safework/cis/products/safetytm/glossary.htm>]

Biological Agent - One of a number of agents such as bacteria, viruses, fungi and other micro-organisms or parts of them and their associated toxins, including those which have



been genetically modified, cell cultures or endoparasites which are potentially hazardous to human health. Note: Dusts of organic origin, for example, cotton dust, flour dust and wood dust, are not considered to be biological agents and are therefore not covered by this definition. [Source: ISO [2015]. ISO 18158 Workplace air – terminology. Geneva: International Organization for Standardization.]

Biological Matrix - A discrete material of biological origin that can be sampled and processed in a reproducible manner. Examples are blood, serum, plasma, urine, feces, saliva, sputum, and various discrete tissues. [Source: FDA [2001]. Guidance for industry - bioanalytical method validation, <http://www.fda.gov/downloads/Drugs/Guidances/ucm070107.pdf>.]

Biological Monitoring –

1. The measurements of the absorption of an environmental chemical in the worker by analysis of a biological specimen for the chemical agent, its metabolites or some specific effect on the worker. [Source: NIOSH [1994]. NIOSH Manual of analytical methods (NMAM), 4th ed. DHHS (NIOSH) Publication No. 94-113.]
2. The periodic examination of biological specimens (in accordance with the definition of monitoring). It is usually applied to exposure monitoring but can also apply to effect monitoring. [Source: ILO/IPCS. Glossary of terms on chemical safety (after WHO, 1979), <http://www.ilo.org/legacy/english/protection/safework/cis/products/safetytm/glossary.htm>]

Biomarker of Effect/Response - A measurable biochemical, physiologic, behavioral, or other alteration in an organism that, depending on the magnitude, can be recognized as associated with an established or possible health impairment or disease [Source: National Research Council of the National Academies (NRC) [2006]. Human Biomonitoring for Environmental Chemicals. Washington DC: The National Academies Press, <http://www.nap.edu/catalog/11700/human-biomonitoring-for-environmental-chemicals>.]

Biomarker of Exposure (e.g., Biological Indicator of Exposure) - A chemical, its metabolite, or product of an Interaction between a chemical or some target molecule or cell that is measured in and organism, such as humans [Source: National Research Council of the National Academies (NRC) [2006]. Human Biomonitoring for Environmental Chemicals. Washington DC: The National Academies Press, <http://www.nap.edu/catalog/11700/human-biomonitoring-for-environmental-chemicals>.]

Biomarker of Susceptibility - An indicator of an inherent or acquired ability of an organism to respond to exposure to a specific chemical substance. Such an indicator may be the result of



a genetic factor, nutritional status, lifestyle, or life stage that affect susceptibility to a chemical exposure. This kind of biomarker can be used to distinguish susceptible individuals or groups; for example, a cytochrome phenotype. [Source: U.S. Environmental Protection Agency (EPA) [2016]. Defining pesticide biomarkers, <http://www.epa.gov/pesticide-science-and-assessing-pesticide-risks/defining-pesticide-biomarkers>.]

Biomonitoring - A method used to assess human exposure to chemicals by measuring a chemical, its metabolite, or a reaction product in human tissues or specimens, such as blood and urine. [Source: National Research Council of the National Academies (NRC) [2006]. Human Biomonitoring for Environmental Chemicals. Washington DC: The National Academies Press, <http://www.nap.edu/catalog/11700/human-biomonitoring-for-environmental-chemicals>.]

Blank - See Field blank, Media blank, and Reagent blank.

Blank Sample - Unused collection substrate, taken from the same batch used for sampling, processed so as to measure artifacts in the measurement (sampling and analysis) process. [Source: CEN [2005]. EN 14902, Ambient air quality — Standard method for the measurement of Pb, Cd, As and Ni in the PM₁₀ fraction of suspended particulate matter. Brussels: European Standards Commission.]

BP - Boiling point, °C.

Breakthrough Volume - Volume of air that can be passed through a sampler before the gas or vapor exceeds the capacity of the sampler. [Source: ISO [2015]. ISO 18158 Workplace air – terminology. Geneva: International Organization for Standardization.]

Breathing Zone - The space around a worker's face from where he or she takes his or her breath. For technical purposes a more precise definition is as follows: A hemisphere of radius 0.3 m extending in front of the human face, centered on the midpoint of a line joining the ears; the base of the hemisphere is a plane through this line, the top of the head and the larynx. The definition is not applicable when respiratory protective equipment is used. [Source: CEN [2011]. EN 1540, Workplace atmospheres – terminology. Brussels: European Standards Commission.]

C

C –

1. Concentration of gaseous, liquid, or solid substance in air, mg/m³;
2. Acceptable ceiling concentration (for a specified maximum time of exposure)



when applied to personal permissible exposure limits.

Calibration Graph - Plot of analytical response vs. known mass or concentration of analyte.

CAS # - Chemical Abstracts Service Registry Number.

CE - Collection efficiency, expressed as a decimal fraction.

Chemical Agent - Chemical element or compound on its own or admixed as it occurs in the natural state or as produced, used, or released, including release as waste, by any work activity, whether or not produced intentionally and whether or not placed on the market. [Source: ISO [2015]. ISO 18158 Workplace air – terminology. Geneva: International Organization for Standardization.]

Chronic Exposure - A continuous or intermittent long-term contact between an agent and a target. (Other terms, such as "long-term exposure," are also used). [Source: Zartarian V, Bahadori T, McKone T [2005]. Adoption of an official ISEA glossary. J Expo Anal Environ Epidemiol. 15:1-5.]

49 CFR 171-177 - Title 49 (Transportation), Code of Federal Regulations. U. S. regulations governing shipment of hazardous materials.

Conc. - Concentrated; concentration

Concentration –

1. A general term referring to the quantity of a material or substance contained in unit quantity of a given medium. [Source: ILO/IPCS. Glossary of terms on chemical safety (after WHO, 1979), <http://www.ilo.org/legacy/english/protection/safework/cis/products/safetytm/glossary.htm>]
2. The quantity of a substance contained in a total unit quantity of sample. [Source: ASTM [2014]. D1356, Standard terminology relating to sampling and analysis of atmospheres. West Conshohocken, PA: ASTM International.]

Control (biological) - A value or group of values of a biological monitoring parameter collected from workers with little or no occupational exposure to the specific chemical agent. [Source: NIOSH [1994]. NIOSH Manual of analytical methods (NMAM), 4th ed. DHHS (NIOSH) Publication No. 94-113.]

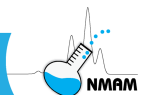

C_v - Concentration of gaseous substance in air, parts per million (V/V). In this manual, C_v is referred to NTP such that $C_v = (C \times 24.46)/MW$.

Cumulative Exposure - The sum of exposures of an organism to a pollutant over a period of time. [Source: EPA [1997]: EPA Terms of Environment – Glossary of Exposure Assessment Related Terms: A Compilation. Prepared by the Exposure Terminology Subcommittee of the IPCS Exposure Assessment Planning Workgroup for the International Programme on Chemical Safety Harmonization of Approaches to the Assessment of Risk from Exposure to Chemicals, 2001.]

CV - See S_r : Estimate of the relative standard deviation, equal to S (sample standard deviation) divided by the mean of a series of measurements. A measure of precision; previously referred to as CV (coefficient of variation). [Source: NIOSH [1994]. NIOSH Manual of analytical methods (NMAM), 4th ed. DHHS (NIOSH) Publication No. 94-113.]

D

D - Density, g/cm³

DE - Desorption efficiency; fraction of known quantity of analyte recovered from spiked solid sorbent media blank. DE may be a function of loading, and should be determined by the chemist for each lot of solid sorbent used for sampling, in the concentration range of interest. Plot (mass recovered minus average media blank)/ mass added vs. (mass recovered minus average media blank). [Source: NIOSH [1994]. NIOSH Manual of analytical methods (NMAM), 4th ed. DHHS (NIOSH) Publication No. 94-113.]

Detector - The part of the monitor that sees and/or measures and/or quantifies and/or ascertains the dimensions, quantity, or concentration of the gas or vapor of interest. [Source: NIOSH [1994]. NIOSH Manual of analytical methods (NMAM), 4th ed. DHHS (NIOSH) Publication No. 94-113.]

D_s - Stokes diameter.

Detection Limit - See LOD; MDL. Lowest amount of an analyte that is detectable with a given confidence level. Note: The detection limit can be calculated as three times the standard deviation of blank measurements. This represents a probability of 50% that the analyte will not be detected when it is present at the concentration of the detection limit. [Source: ISO [2015]. ISO 18158 Workplace air – terminology. Geneva: International Organization for Standardization.]

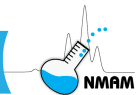

Diffusive Sampler –

1. Device which is capable of taking samples of gases or vapors from the atmosphere at a rate controlled by a physical process such as gaseous diffusion through a static air layer or permeation through a membrane, but which does not involve active movement of air through the sampler. [Source: ASTM [2014]. D1356, Standard terminology relating to sampling and analysis of atmospheres. West Conshohocken, PA: ASTM International.]
2. Passive sampler that collects gases or vapors at a rate governed by diffusion through a static air layer and/or permeation through a membrane. [Source: ISO [2015]. ISO 18158 Workplace air – terminology. Geneva: International Organization for Standardization.]

Dose –

1. The amount of agent that enters a target after crossing an exposure surface. If the exposure surface is an absorption barrier, the dose is an absorbed dose/uptake dose (see uptake); otherwise it is an intake dose (see intake). [Source: Zartarian V, Bahadori T, McKone T [2005] Adoption of an official ISEA glossary. J Expo Anal Environ Epidemiol, 15:1-5.]
2. The amount of a chemical administered to an organism. [Source: ILO/IPCS. Glossary of terms on chemical safety (after WHO, 1979), <http://www.ilo.org/legacy/english/protection/safework/cis/products/safetytm/glossary.htm>]

Dosimeter - An instrument to measure dosage; many so called dosimeters actually measure exposure rather than dosage. [Source: EPA [1997] EPA Terms of Environment – Glossary of Exposure Assessment Related Terms: A Compilation. Prepared by the Exposure Terminology Subcommittee of the IPCS Exposure Assessment Planning Workgroup for the International Programme on Chemical Safety Harmonization of Approaches to the Assessment of Risk from Exposure to Chemicals, 2001.]

Dosimetry - Process or technology of measuring and/or estimating dosage. [Source: EPA [1997] EPA Terms of Environment – Glossary of Exposure Assessment Related Terms: A Compilation. Prepared by the Exposure Terminology Subcommittee of the IPCS Exposure Assessment Planning Workgroup for the International Programme on Chemical Safety Harmonization of Approaches to the Assessment of Risk from Exposure to Chemicals, 2001.]

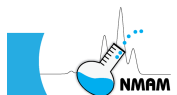

E

ECD - Electron capture detector

EPA - U.S. Environmental Protection Agency

Est - Estimated

Exposure -

1. Contact between an agent and a target. Contact takes place at an exposure surface over an exposure period. [Source: Zartarian V, Bahadori T, McKone T [2005]. Adoption of an official ISEA glossary. *Jour Expo Anal & Environ Epidemiol*, 15:1–5.]
2. The amount of an environmental agent that has reached the individual (external dose) or has been absorbed into the individual (internal dose, absorbed dose). [Source: ILO/IPCS. Glossary of terms on chemical safety (after WHO, 1979), <http://www.ilo.org/legacy/english/protection/safework/cis/products/safetytm/glossary.htm>]
3. (By inhalation) Situation in which a chemical agent or biological agent is present in the air that is inhaled by a person. [Source: ISO [2015]. ISO 18158 Workplace air – terminology. Geneva: International Organization for Standardization.]

Exposure Assessment -

1. The process of estimating or measuring the magnitude, frequency and duration of exposure to an agent, along with the number and characteristics of the population exposed. Ideally, it describes the sources, pathways, routes, and the uncertainties in the assessment. [Source: Zartarian V, Bahadori T, McKone T Adoption of an official ISEA glossary. *J Expo Anal Environ Epidemiol*, 15:1–5.]
2. The quantification of the amount of exposure to a hazard for an individual or group [Source: ILO/IPCS. Glossary of terms on chemical safety (after WHO, 1979), <http://www.ilo.org/legacy/english/protection/safework/cis/products/safetytm/glossary.htm>]

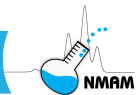

Exposure Concentration - The exposure mass divided by the contact volume or the exposure mass divided by the mass of contact volume depending on the medium. [Source: Zartarian V, Bahadori T, McKone T [2005]: Adoption of an official ISEA glossary. *J Expo Anal Environ Epidemiol*, 15:1–5.]

Exposure Route - The way an agent enters a target after contact (e.g., by ingestion, inhalation, or dermal absorption). [Source: Zartarian V, Bahadori T, McKone T [2005]: Adoption of an official ISEA glossary. *J Expo Anal Environ Epidemiol*, 15:1–5.]

F

F - Fiber(s)

FID - (Hydrogen-air) flame ionization detector

Field Blank –

1. A sample (or sampler) handled exactly the same as the field samples, except no air is drawn through it. Used to estimate contamination in preparation for sampling, shipment and storage prior to measurement, but not actually subtracted from sample readings (see media blank). [Source: NIOSH [1994]. *NIOSH Manual of analytical methods (NMAM)*, 4th ed. DHHS (NIOSH) Publication No. 94-113.]
2. Blank (sample) that is transported to the sampling site, but not used for sample collection. Discussion: A field blank is loaded in the sampler, where applicable, and returned to the laboratory in the same way as a sample. The results from the analysis of field blanks are used to identify contamination of the sample arising from handling in the field and during transport. [Source: ISO [2015]. *ISO 18158 Workplace air – terminology*. Geneva: International Organization for Standardization.]

FPD - Flame photometric detector

FTIR - Fourier transform infrared spectroscopy

G

GC - Gas chromatography

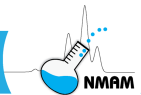

GFAAS - Graphite furnace atomic absorption spectrometry

GPO - U.S. Government Printing Office, Washington, DC 20402

H

Hemolysis - Rupture of red blood cells. [Adapted from Webster's English dictionary online, <http://www.merriam-webster.com/>]. Discussion: hemolysis may occur due to improper collection and handling of whole blood samples.

HGAAS - Hydride generation atomic absorption spectrometry

Hydrolysis - Chemical process of decomposition involving the splitting of a bond and the addition of the hydrogen cation and the hydroxide anion of water [Source: Webster's English dictionary online, <http://www.merriam-webster.com/>]

HPLC - High performance liquid chromatography

I

IC - Ion chromatography; ion-exchange chromatography

ICP-AES - Inductively coupled plasma - atomic emission spectrometry, also called ICP.

Internal Capsule - Air sampler insert consisting of a plastic housing (with an air inlet) attached to a membrane filter. Discussion: The internal capsule is fabricated so as to fit inside the body of the sampling device (e.g., closed-face cassette sampler), enabling capture of airborne particles within the housing / filter construct. [Adapted from: Harper M, Ashley K [2013]: Acid-soluble internal capsules for closed-face cassette elemental sampling and analysis of workplace air. *J Occup Environ Hyg* 10:297-306.]

Interference Equivalent - Mass or concentration of interfering substance (interferant) which gives the same measurement reading as unit mass or concentration of substance being measured. [Source: NIOSH [1994]. NIOSH Manual of analytical methods (NMAM), 4th ed. DHHS (NIOSH) Publication No. 94-113.]

Interferent - Constituent of the (air) sample or other aspect of the sampling or analytical procedure having an adverse effect on the accuracy of the measurement. Note: Interferents can include components of sampling or analysis equipment, reagents, etc. [Source: ISO



[2015]. ISO 18158 Workplace air – terminology. Geneva: International Organization for Standardization.]

IR – Infrared

L

LAQL - Lowest analytically quantifiable level; see LOQ.

LC - Liquid chromatography

LOD –

1. Limit of detection (detection limit); smallest amount of analyte which can be distinguished from background. A good estimate for unbiased analyses, with media blanks not distinguishable from background, is three times the standard error of the calibration graph for low concentrations, divided by the slope (instrument reading per unit mass or per unit concentration of analyte). [Source: NIOSH [1994]. NIOSH Manual of analytical methods (NMAM), 4th ed. DHHS (NIOSH) Publication No. 94-113.]
2. The lowest concentration of an analyte that the bioanalytical procedure can reliably differentiate from background noise. [Source: FDA [2001]. Guidance for industry - bioanalytical method validation, <http://www.fda.gov/downloads/Drugs/Guidances/ucm070107.pdf>.]
3. The smallest amount, or lowest concentration, of a given substance that a given procedure will detect [Source: ILO/IPCS. Glossary of terms on chemical safety (after WHO, 1979), <http://www.ilo.org/legacy/english/protection/safework/cis/products/safetytm/glossary.htm>]

LOQ - Limit of quantitation; mass of analyte equal to 10 times the standard error of the calibration graph divided by the slope; approximately the mass of analyte for which relative standard deviation, S_r , equals 0.10. [Source: NIOSH [1995]: Guidelines for air sampling and analytical method development and evaluation. By Kennedy ER, Fischbach TJ, Song R, Eller PM, Shulman SA. DHHS (NIOSH) Publication No. 95-117, <http://www.cdc.gov/niosh/docs/95-117/pdfs/95-117.pdf>.]

Limit of Quantification - Synonymous with limit of quantitation, LOQ. Mass of analyte equal to 10 times the standard error of the calibration graph divided by the slope;



approximately the mass of analyte for which relative standard deviation, S_r , equals 0.10. [Source: NIOSH [1995]: Guidelines for air sampling and analytical method development and evaluation. By Kennedy ER, Fischbach TJ, Song R, Eller PM, Shulman SA. DHHS (NIOSH) Publication No. 95-117, <http://www.cdc.gov/niosh/docs/95-117/pdfs/95-117.pdf>.]

LTA - Low temperature (oxygen plasma) ashing

M

MCE; MCEF - Mixed cellulose ester; Mixed cellulose ester membrane filter

MDL - Method detection limit; mass of analyte equal to 3 times the standard error of the calibration graph divided by the slope; approximately the mass of analyte for which standard deviation, S_r , equals 0.03. [Source: NIOSH [1995]: Guidelines for air sampling and analytical method development and evaluation. By Kennedy ER, Fischbach TJ, Song R, Eller PM, Shulman SA. DHHS (NIOSH) Publication No. 95-117, <http://www.cdc.gov/niosh/docs/95-117/pdfs/95-117.pdf>.]

Metabolite –

1. A substance produced directly by a biotransformation of a chemical. For example, phenol in urine is a metabolite of benzene and is representative of benzene absorption in the worker. [Source: NIOSH [1994]. NIOSH Manual of analytical methods (NMAM), 4th ed. DHHS (NIOSH) Publication No. 94-113.]
2. A substance resulting from chemical transformation in an organism. [Source: ILO/IPCS. Glossary of terms on chemical safety (after WHO, 1979), <http://www.ilo.org/legacy/english/protection/safework/cis/products/safetytm/glossary.htm>]

Microbiome - The complete genetic content of all the microorganisms that typically inhabit a particular environment, especially a site on or in the body, such as the skin or the gastrointestinal tract. [Source: Medical Dictionary online, <http://www.online-medical-dictionary.org/>]

Measurement Range - Range of substance, in mass per sample, from the LOQ (or from 10 times the LOD, if LOQ is not known) to an upper limit characteristic of the analytical method, e.g., the limit of linearity or the mass at which precision of the method starts to become worse than $S_r = 0.1$. [Source: NIOSH [1995]: Guidelines for air sampling and analytical method development and evaluation. By Kennedy ER, Fischbach TJ, Song R, Eller PM, Shulman SA.



DHHS (NIOSH) Publication No. 95-117, <http://www.cdc.gov/niosh/docs/95-117/pdfs/95-117.pdf>.]

Media Blank - An unexposed sampler, not taken or shipped to the field, used for background correction of sample readings or for recovery studies. [Source: NIOSH [1994]. NIOSH Manual of analytical methods (NMAM), 4th ed. DHHS (NIOSH) Publication No. 94-113.]

MP - Melting point, °C

MS - Mass spectrometry

MW - Molecular weight

N

Nanoparticle - Material with all three dimensions in the size range from approximately 1 nm to 100 nm [Source: ISO [2015]. ISO 18158 Workplace air – terminology. Geneva: International Organization for Standardization.]

NIOSH - National Institute for Occupational Safety and Health, Centers for Disease Control and Prevention, Public Health Service, U. S. Department of Health and Human Services.

Normal Range (biological) - The range of values for an analyte of interest in biological monitoring that would be expected in workers without exposure to the environmental chemical agent in the workplace. Note: Normal ranges are often method-specific. [Adapted from: NIOSH [1994]. NIOSH Manual of analytical methods (NMAM), 4th ed. DHHS (NIOSH) Publication No. 94-113.]

NTIS - National Technical Information Service, Springfield, VA 22161.

NTP - Normal temperature and pressure, 25 °C (298 K) and 101.33 kPa (760 mm Hg), at which the molar volume of an ideal gas is 24.46 L.

O

OSHA - Occupational Safety and Health Administration, U. S. Department of Labor.

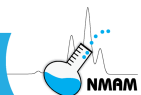
**P****P –**

1. Peak (maximum permissible instantaneous) concentration;
2. Pressure, in kPa, at which sampling pump is calibrated or when air sample was taken.

PAH - Polynuclear aromatic hydrocarbons; PNAH

PCM - Phase contrast microscopy

PEL - OSHA PEL; OSHA permissible exposure limit, expressed as ppm or mg/m³ (of a substance in air).

Personal Exposure Monitor - Device used to measure an individual's personal exposure to environmental contaminants or other stressors. A device worn on or near the contact boundary that measures concentration [Source: Zartarian VG, Ott WR, Duan N [1997]. A quantitative definition of exposure and related concepts. *J Exposure Anal Environ Epidemiol* 7(4):411-437. and EPA [1997] EPA Terms of Environment – Glossary of Exposure Assessment Related Terms: A Compilation. Prepared by the Exposure Terminology Subcommittee of the IPCS Exposure Assessment Planning Workgroup for the International Programme on Chemical Safety Harmonization of Approaches to the Assessment of Risk from Exposure to Chemicals, 2001.]

Personal Sampler - Sampling device, attached to a person that collects gases, vapors, or airborne particles in the breathing zone for the purpose of measuring exposure to chemical agents and/or biological agents. [Source: ISO [2015]. ISO 18158 Workplace air – terminology. Geneva: International Organization for Standardization.]

PID - Photoionization detector

Plasma, blood - The clear supernatant from whole blood collected with anticoagulants. Discussion: Blood is collected, mixed with the anticoagulant and centrifuged to separate the plasma from red blood cells. [Adapted from Medical Dictionary online, <http://www.online-medical-dictionary.org/>.]

PLM - Polarized light microscopy



Pool (biological) - A combination of biological specimens (i.e., urine or serum) from many workers that is used to prepare small aliquots to be run with each batch of analyses. NOTE: The analyte must be stable in the biological matrix and under the storage conditions used. Discussion: Aliquots of these pools are analyzed with each batch of samples and the data are used to develop quality control charts. [Source: NIOSH [1994]. NIOSH Manual of analytical methods (NMAM), 4th ed. DHHS (NIOSH) Publication No. 94-113.]

Precision –

1. The relative variability of measurements on replicate samples about the mean of the population of measurements. Discussion: Precision is expressed by the relative standard deviation of a series of measurements, and reflects the ability of a method to replicate measurement results. [Source: NIOSH [1995]: Guidelines for air sampling and analytical method development and evaluation. By Kennedy ER, Fischbach TJ, Song R, Eller PM, Shulman SA. DHHS (NIOSH) Publication No. 95-117, <http://www.cdc.gov/niosh/docs/95-117/pdfs/95-117.pdf>.]
2. The repeatability or reproducibility of individual measurements expressed as standard deviation, S , or relative standard deviation, S_r (q.v.). See Accuracy. [Source: NIOSH [2003]. Glossary of abbreviations, definitions, and symbols. In: NIOSH Manual of analytical methods (NMAM), 4th ed. DHHS (NIOSH) Publication No. 94-113, <http://www.cdc.gov/niosh/docs/2003-154/pdfs/glossary.pdf>.]
3. The closeness of agreement (degree of scatter) between a series of measurements obtained from multiple sampling of the same homogenous sample under the prescribed conditions. [Source: FDA [2001]. Guidance for industry - bioanalytical method validation, <http://www.fda.gov/downloads/Drugs/Guidances/ucm070107.pdf>.]

Proficiency Testing - Any interlaboratory testing program where stable specimens are sent to participating laboratories for analysis. Discussion: Results from all participating laboratories are compared, pooled, and tabulated by the testing program operator with the purpose of improving laboratory performance. [Adapted from Medical Dictionary online, <http://www.online-medical-dictionary.org/>.]

PTFE - Polytetrafluoroethylene

PVC - Polyvinyl chloride

**Q**

Q - Sampling flow rate, L/min

Quantification Range - The range of concentrations, including upper and lower quantification limits (ULOQ and LLOQ, respectively), that can be reliably and reproducibly quantified with accuracy and precision through the use of a concentration-response relationship. [Source: FDA [2001]. Guidance for industry - bioanalytical method validation, <http://www.fda.gov/downloads/Drugs/Guidances/ucm070107.pdf>.]

R

Reagent Blank - All reagents used in sample preparation, in the same quantities used to prepare blank and sample solutions. Note: The reagent blank is used to assess contamination from the laboratory environment and to characterize background from the reagents used in sample preparation. [Source: ISO [2015]. ISO 18158 Workplace air – terminology. Geneva: International Organization for Standardization.]

Recovery, R -

1. Fraction recovered (see DE); previously associated with Analytical Method Recovery (AMR), a term which is no longer preferred. [Source: NIOSH [1994]. NIOSH Manual of analytical methods (NMAM), 4th ed. DHHS (NIOSH) Publication No. 94-113.]
2. The extraction efficiency of an analytical process, reported as a percentage of the known amount of an analyte carried through the sample extraction and processing steps of the method. [Source: FDA [2001]. Guidance for industry - bioanalytical method validation, <http://www.fda.gov/downloads/Drugs/Guidances/ucm070107.pdf>.]

Relative Standard Deviation (RSD) - Quotient of standard deviation over the mean; See S_r and Precision.

Repeatability - The variation in measurements taken under the same conditions. [Adapted from: ISO [2015]. ISO 18158 Workplace air – terminology. Geneva: International Organization for Standardization.]

Reproducibility - A measure of the precision of a method under the same operating conditions on the same sample over short period of time. [Adapted from ASTM [2014].]



D1356, Standard terminology relating to sampling and analysis of atmospheres. West Conshohocken, PA: ASTM International.]

Respirable Dust - Dust deposited in the non-ciliated portions of the lungs. Discussion: Respirable dust is measured by using a respirable sampler when the respirable fraction of airborne dust is of interest. [Adapted from ISO [1995]. ISO 7708 Air quality — particle size fraction definitions for health-related sampling.’ Geneva: International Organization for Standardization.]

R_f - In thin-layer chromatography, the ratio of distance travelled by the analyte from point of application to that of the solvent front.

RF - Radio frequency

Rotameter - A device, based on the principle of Stoke’s Law, for measuring rate of fluid flow, consisting of a tapered vertical tube having a circular cross section, and containing a float that is free to move in a vertical path to a height dependent upon the rate of fluid flow upward through the tube. [Source: ASTM [2014] D1356, Standard terminology relating to sampling and analysis of atmospheres. West Conshohocken, PA: ASTM International.]

RTECS - Registry of Toxic Effects of Chemical Substances (NIOSH)

Ruggedness Test - Partial or complete analysis of variance using experiments in which operational parameters of a sampling and measurement method are varied within a small range to determine their effect on overall variance [Source: Youden W, Steiner EH [1975]: Statistical manual of the AOAC, Arlington, VA: Association of Official Analytical Chemists.]

S

S -

1. Estimate of the standard deviation;
2. Specific mass, particles/mg.

S_b - Estimate of the standard deviation of media blank

S_r - Estimate of the relative standard deviation, equal to S divided by the mean of a series of measurements. A measure of precision. Equivalent to CV (coefficient of variation).

\bar{S}_r - Pooled relative standard deviation



$\widehat{S}_{r,T}$ - Estimate of overall precision including pump error

Sample Dissolution - The process of obtaining a solution containing the analyte(s) of interest from a sample. This may or may not involve complete dissolution of the sample. [Source: ASTM [2010]. D7035, Standard test method for determination of metals and metalloids in airborne particulate matter by inductively coupled plasma atomic emission spectrometry (ICP-AES). West Conshohocken, PA: ASTM International.]

Selectivity -

1. The ability of a bioanalytical method to measure and differentiate the analytes in the presence of interfering components that may be expected to be present. These could include metabolites, impurities, degradants, or matrix components. [Adapted from Medical Dictionary online, [http://www.online-medical-dictionary.org/.](http://www.online-medical-dictionary.org/)]
2. Extent of independence of a measuring procedure from interferences. [Source: ISO [2015]. ISO 18158 Workplace air – terminology. Geneva: International Organization for Standardization.]

Screening Test (biological) - An easily performed method, often relatively non-specific, to assess worker exposure to a class of compounds by use of biological monitoring. [Source: NIOSH [1994]. NIOSH Manual of analytical methods (NMAM), 4th ed. DHHS (NIOSH) Publication No. 94-113.]

SEM - Scanning electron microscopy

Sensitivity -

1. The slope of the calibration curve. If the curve is in fact a ‘curve’, rather than a straight line, then of course sensitivity will be a function of analyte concentration or amount. If sensitivity is to be a unique performance characteristic, it must depend only on the chemical measurement process, not upon scale factors. [Source: Currie LA [1995] Nomenclature in evaluation of analytical methods including detection and quantification capabilities. Pure & Appl Chem 67(10):1699-1723.]
2. The smallest change in the measured analyte concentration that will produce a reproducible change in a monitor’s readout. [Source: NIOSH [2012]. NIOSH Technical report: Components for evaluation of direct-reading monitors for gases and vapors. DHHS (NIOSH) Publication No. 2012-162, [http://www.cdc.gov/niosh/docs/2012-162/pdfs/2012-162.pdf.](http://www.cdc.gov/niosh/docs/2012-162/pdfs/2012-162.pdf)]

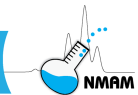

Serum - The clear supernatant from whole blood collected without anticoagulants, allowed to clot (30 minutes) and centrifuged to separate serum from the clotted blood. Serum does not contain clotting factors. [Adapted from Medical Dictionary online, <http://www.online-medical-dictionary.org/>.]

Sorbent Tube - Sorbent or a support impregnated with reagent, through which sampled air passes. Note: Some sorbent tubes are intended for use as active samplers and some as passive samplers. [Source: ISO [2015]. ISO 18158 Workplace air – terminology. Geneva: International Organization for Standardization.]

Spike - A known mass of analyte added to a sampler for the purpose of determining recovery (analyst spikes), or for quality control (blind spikes). Also see DE. [Source: NIOSH [1994]. NIOSH Manual of analytical methods (NMAM), 4th ed. DHHS (NIOSH) Publication No. 94-113.]

Sp. gr. - Specific gravity. Relative to water at the same temperature.

Spot Sample (urine) - Urine sample collected at a specified time. [Source: NIOSH [1994]. NIOSH Manual of analytical methods (NMAM), 4th ed. DHHS (NIOSH) Publication No. 94-113.]

STEL - Short-Term (15-min) Exposure Limit.

T

T - Retention time, min

t -

1. Temperature, °C;
2. Time, min.

T_c - Temperature, degrees kelvin (K), at which sampling pump was calibrated

TEM - Transmission electron microscopy

TLC - Thin-layer chromatography

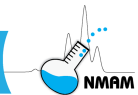

TLV - Threshold limit value, listed in TLVs® and BEIs®, Threshold Limit Values for Chemical Substances and Physical Agents and Biological Indices (American Conference of Governmental Industrial Hygienists, Cincinnati, OH, 2015; updated annually).

T_s - Temperature, kelvins (K), at which air sample was taken

TWA - Time-weighted average; the concentration of a chemical or biological agent in the atmosphere, averaged over the reference period. [Adapted from: ISO [2015]. ISO 18158 Workplace air – terminology. Geneva: International Organization for Standardization.]

U

Ultrafine Particle - Particle with a nominal diameter (such as geometric, aerodynamic, mobility, projected-area or otherwise) of 100 nm or less, produced as a by-product of a process such as welding and combustion. [Source: ISO [2015]. ISO 18158 Workplace air – terminology. Geneva: International Organization for Standardization.]

Uncertainty - A limited knowledge of the agreement between data, information, or outcomes relative to an unknown truth. The uncertainty of a measurement is the parameter associated with the result of a measurement that characterizes the dispersion of the values that could reasonably be attributed to the measurand (the quantity being measured). [Source: Taylor BN, Kuyatt CE [1994]. NIST Technical note 1297, Guidelines for evaluating and expressing the uncertainty of NIST measurement results. Gaithersburg, MD, National Institute of Standards and Technology (NIST).]

User Check - An evaluation of a written procedure for clarity and accuracy in which an independent laboratory analyzes a small number of spiked samples following a draft sample preparation and analysis exactly as written and reviews the draft method for clarity. [Source: NIOSH [1994]. NIOSH Manual of analytical methods (NMAM), 4th ed. DHHS (NIOSH) Publication No. 94-113.]

UV - Ultraviolet



V

V - Volume of air sample, in L, as taken at the sampling site, corrected if necessary for rotameter calibration at a different temperature and pressure:

$$V = (\text{flow rate})(\text{time}) \left(\frac{P_c T_s}{P_s T_c} \right)^{0.5}$$

Validated Method - A Method which meets or exceeds certain sampling and measurement performance criteria; see for example, the criteria given in Chapter ME [Source: NIOSH [2016]. Development and evaluation of methods. In: NIOSH Manual of analytical methods, 5th ed. DHHS (NIOSH) Publication No. 2014-151, <http://www.cdc.gov/niosh/nmam>.]

Validation - Process of evaluating the performance of a measuring procedure and checking that the performance meets certain pre-set criteria. Discussion: Performance characteristics to be considered include confirmation of identity, selectivity/ specificity, limit of detection, limit of quantification, analytical recovery, working and linear dynamic ranges, accuracy, measurement repeatability, measurement reproducibility, ruggedness, and robustness. [Source: CEN [2011]. EN 1540, Workplace atmospheres – terminology. Brussels: European Standards Commission.]

Vapor –

1. The gaseous phase of matter that normally exists in a liquid or solid state [Source: ASTM [2014]. D1356, Standard terminology relating to sampling and analysis of atmospheres. West Conshohocken, PA: ASTM International.]
2. Gas phase of a substance in a state of equilibrium or disturbed equilibrium with the same substance in a liquid or solid state below its boiling or sublimation point [Source: CEN [2011]. EN 1540, Workplace atmospheres – terminology. Brussels: European Standards Commission.]

V_m - Volume of 1 mole of ideal gas at the specified temperature and pressure (e.g., 24.45 L at 25 °C and 1 atmosphere).

VOL-MAX - Maximum recommended air sample volume, L, based on sampler capacity or other limitation, at the OSHA PEL

VOL-MIN - Minimum recommended air sample volume, L, based on an atmosphere at the OSHA PEL concentration and collecting a mass of substance which is equal to the LOQ. See also Working range.

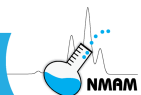

VP - Vapor pressure

W

W - Mass of analyte found on an exposed single-section sampler (e.g., membrane filter)

W_b - Mass of analyte found on the back section of an exposed sampler

W_f - Mass of analyte found on the front section of an exposed sampler

Working Range - Range of air concentrations, in ppm or mg/m³, at specified air sample volume, extending from the LOQ to a maximum determined by sampler capacity or measurement considerations. [Source: NIOSH [1994]. NIOSH Manual of analytical methods (NMAM), 4th ed. DHHS (NIOSH) Publication No. 94-113.]

X

XRD - X-ray diffraction

XRF - X-ray fluorescence

Disclaimer

Mention of any company or product does not constitute endorsement by NIOSH. In addition, citations to websites external to NIOSH do not constitute NIOSH endorsement of the sponsoring organizations or their programs or products. Furthermore, NIOSH is not responsible for the content of these websites. All web addresses referenced in this document were accessible as of the publication date.

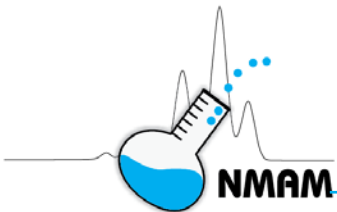

METHODS

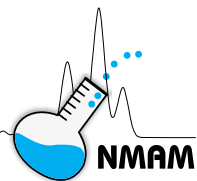

PARTICULATES NOT OTHERWISE REGULATED, TOTAL

0501

DEFINITION: total aerosol mass

CAS: NONE

RTECS: NONE

METHOD: 0501, Issue 1

EVALUATION: FULL

Issue 1: 8 May 2015

OSHA: 15 mg/m³, total dust (inert or nuisance dust; particles not otherwise regulated) [1] **PROPERTIES:** Contains no asbestos and less than 1% quartz

NIOSH: no REL

For other OELs and guidelines: See references [2,3]

SYNONYMS: Nuisance dusts; particles not otherwise specified (PNOS)

| SAMPLING | MEASUREMENT |
|---|--|
| <p>SAMPLER: INTERNAL CAPSULE (tared 37-mm, 2- to 5-μm PVC filter melded to PVC housing) in 37-mm 2-piece cassette</p> <p>FLOW RATE: 1 to 2 L/min</p> <p>VOL-MIN: 17 L @ 15 mg/m³- -MAX: 333 L @ 15 mg/m³</p> <p>SHIPMENT: Routine</p> <p>SAMPLE STABILITY: 28 days minimum</p> <p>BLANKS: Minimum of 2 field blanks per batch</p> | <p>TECHNIQUE: GRAVIMETRIC (INTERNAL CAPSULE WEIGHT)</p> <p>ANALYTE: Airborne particulate material</p> <p>BALANCE: 0.001 mg sensitivity; use same balance before and after sample collection</p> <p>CALIBRATION: National Institute of Standards & Technology Class S-1.1 weights or ASTM Class 1 weights</p> <p>RANGE: 0.25 to 5 mg per sample</p> <p>ESTIMATED LOD: 0.075 mg per sample</p> |
| ACCURACY | <p>PRECISION (\bar{S}_r): 0.031 @ \approx2 mg per sample [4]</p> |
| <p>RANGE STUDIED: 0.1 to 4 mg per sample</p> <p>BIAS: 0.058 [4]</p> <p>OVERALL PRECISION (\hat{S}_{rr}): 0.059 [4]</p> <p>ACCURACY: \pm 15.5%</p> | |

APPLICABILITY: The working range is 2.5 to 50 mg/m³ for a 100-L air sample. This method is nonspecific and determines the 'total' dust concentration to which a worker is exposed.

INTERFERENCES: Moisture and static electricity can affect gravimetric measurements. Humidity control and minimization of static effects are addressed in this procedure.

OTHER METHODS: The method is similar to Method 5100 for carbon black [5]. This method is preferred over 0500, Issue 2 [6]. OSHA method PV2121 describes a similar procedure (but for respirable sampling) using an alternative sampler design [7].

EQUIPMENT:

1. Sampler: Internal capsule, 37-mm polyvinyl chloride (PVC), 2- to 5- μ m pore size membrane or equivalent hydrophobic filter attached to PVC housing and supporting pad in 37-mm 2-piece cassette filter holder

NOTE: The cassettes should be fabricated so as to ensure complete sealing of the internal capsule after sample collection.

2. Personal sampling pump, 1 to 2 L/min, with flexible connecting tubing
3. Microbalance, capable of weighing to ± 0.001 mg
4. Static neutralizer, e.g., ^{210}Po ; replace no more than nine months after the production date
5. Tool for handling internal capsules, e.g., forceps (preferably plastic)
6. Environmental chamber or room for balance (e.g., $20\text{ }^\circ\text{C} \pm 1\text{ }^\circ\text{C}$ and $50\% \pm 5\% \text{ RH}$)

SPECIAL PRECAUTIONS: None.

PREPARATION OF INTERNAL CAPSULES BEFORE SAMPLING:

1. Equilibrate the PVC filter capsules in an environmentally controlled weighing area or chamber for at least 24 hours.
NOTE: An environmentally controlled chamber is desirable, but not required.
2. Place backup pads in filter cassette bottom sections.
3. Weigh the filter capsules in an environmentally controlled area or chamber. Record the internal capsule tare weight, W_1 (mg).
 - a. Zero the balance before each weighing.
 - b. Handle the filter capsule with forceps. Pass the internal capsule over an antistatic radiation source. Repeat this step if the capsule does not release easily from the forceps or if it attracts the balance pan. Static electricity can cause erroneous weight readings.
4. Assemble the filter capsules in the filter cassettes and close firmly so that leakage around the internal capsule will not occur. Place a plug in each opening of the filter cassette. Place a cellulose shrink band around the filter cassette, allow to dry and label the cassette with indelible ink.

SAMPLING:

5. Calibrate each personal sampling pump with a representative sampler in line.
6. Sample at 1 to 2 L/min for a total sample volume of 17 to 333 L. Do not exceed a total filter capsule loading of approximately 5 mg total dust. Take two to four replicate samples for each batch of field samples for quality assurance on the sampling procedure.

SAMPLE PREPARATION:

7. Wipe dust from the external surface of the filter cassette with a moist paper towelette to minimize contamination. Discard the paper towelette.
8. Remove the top and bottom plugs from the filter cassette. Equilibrate for at least 24 hours in the balance room.
9. Using forceps, open the cassette and remove the internal capsule gently to avoid loss of dust or damage to the capsule.

CALIBRATION AND QUALITY CONTROL:

10. Zero the microbalance before all weighings. Use the same microbalance for weighing filter capsules before and after sample collection. Calibrate the balance with National Institute of Standards and Technology Class S-1.1 or ASTM Class 1 weights.
11. Process laboratory blanks, spiked QC samples and field blanks at a minimum frequency of 1 per 20 field samples. Internal capsules used for QC samples should come from the same lot. Spiked QC samples, loaded with 0.25-4 mg of material per internal capsule, should be prepared using weight-stable material such as Arizona Road Dust [8].

MEASUREMENT:

12. Weigh each capsule, including field blanks. Record the post-sampling weight, W_2 (mg). Record anything remarkable about a capsule (e.g., overload, leakage, wet, torn, etc.).

CALCULATIONS:

13. Calculate the concentration of total particulate matter, C (mg/m³), in the air volume sampled, V (L):

$$C = \frac{(W_2 - W_1) - (B_2 - B_1)}{V} 10^3, \text{ mg/m}^3$$

where: W_1 = tare weight of capsule before sampling (mg)
 W_2 = post-sampling weight of sample-containing capsule (mg)
 B_1 = mean tare weight of blank capsules (mg)
 B_2 = mean post-sampling weight of blank capsules (mg)

EVALUATION OF METHOD:

Lab testing was carried out using blank internal capsules and with capsules spiked with 0.1 – 4 mg of NIST SRM 1648 (Urban Particulate Matter) and Arizona Road Dust (Air Cleaner Test Dust) [4]. Precision and accuracy data are given on page 0501-1. Weight stability over 28 days was verified for both blanks and spiked capsules [4]. Independent laboratory testing on blanks and field samples have verified long-term weight stability as well as sampling and analysis uncertainty estimates [4,8].

REFERENCES:

- [1] CFR. 29 CFR Part 1910.1000. Code of Federal Regulations. Washington, DC: U.S. Government Printing Office, Office of the Federal Register.
- [2] NIOSH [2005]. NIOSH pocket guide to chemical hazards. Barsan ME, ed. Cincinnati OH: U.S. Department of Health and Human Services, Centers for Disease Control and Prevention, National Institute for Occupational Safety and Health. DHHS (NIOSH) Publication no. 2005-149.
- [3] Institut für Arbeitsschutz der Deutschen Gesetzlichen Unfallversicherung [2014]. GESTIS-Database on hazardous substances. (German Social Accident Insurance). Sankt Augustin, Germany: IFA. <https://www.dguv.de/ifa/index-2.jsp> (Date accessed: February, 2015).
- [4] NIOSH [2014]. Backup Data Report-NIOSH 0501 and 5100. By O'Connor SP, O'Connor PF, Feng HA, Ashley K. Cincinnati, OH: U.S. Department of Health and Human Services, Centers for Disease Control and Prevention, National Institute for Occupational Safety and Health. [http://www.cdc.gov/niosh/docs/2003-154/pdfs/bud/1453_bud.pdf].
- [5] NIOSH [2015]. Carbon black: Method 5100. In: Ashley KE, O'Connor PF, eds. NIOSH manual of analytical methods. 5th ed. Cincinnati, OH: U.S. Department of Health and Human Services, Centers

for Disease Control and Prevention, National Institute for Occupational Safety and Health, DHHS (NIOSH) Publication No. 2014-151. [www.cdc.gov/niosh/nmam/].

- [6] NIOSH [1994]. Particulates not otherwise regulated, total: Method 0500. In: Eller PM, Cassinelli ME, eds. NIOSH manual of analytical methods. 4th ed. Cincinnati, OH: U.S. Department of Health and Human Services, Centers for Disease Control and Prevention, National Institute for Occupational Safety and Health, DHHS (NIOSH) Publication No. 94-113 [www.cdc.gov/niosh/nmam/].
- [7] OSHA [2003]. Gravimetric determination: PV2121. In: Monitoring methods used by OSHA. Salt Lake City, UT: U.S. Department of Labor, Occupational Safety and Health Administration. [<https://www.osha.gov/dts/sltc/methods/partial/pv2121/pv2121.html>] (Date accessed: February, 2015).
- [8] O'Connor S, O'Connor PF, Feng HA, Ashley K [2014]. Gravimetric analysis of particulate matter using air samplers housing internal filtration capsules. *Gefahrstoffe Reinh Luft* 75: 403-410.

METHOD WRITTEN BY: Kevin Ashley, Ph.D., NIOSH/DART.

Disclaimer: Mention of any company or product does not constitute endorsement by NIOSH. In addition, citations to websites external to NIOSH do not constitute NIOSH endorsement of the sponsoring organizations or their programs or products. Furthermore, NIOSH is not responsible for the content of these websites. All web addresses referenced in this document were accessible as of the publication date.



VINYL ACETATE

1453

CH₃CO₂CHCH₂

MW: 86.09

CAS: 108-05-4

RTECS: AK0875000

METHOD: 1453, Issue 3

EVALUATION: FULL

Issue 1: 15 August 1994

Issue 3: 15 March 2013

OSHA: None
 MSHA: None
 NIOSH: Ceiling 4 ppm (15 min)
 OTHER OELs: [1,2]

PROPERTIES: Liquid; BP 72.7 °C; d 0.934 g/mL @ 20 °C;
 VP 11.8 kPa (89 mm Hg) @ 20 °C;
 vapor density (air = 1) 3.0

SYNONYMS: Acetic acid, vinyl ester; acetic acid, ethenyl ester; Vinyl A monomer; ethylene ethanoate; 1-acetoxyethylene; ethenyl acetate; vinyl acetate monomer; vinyl ethanoate.

| SAMPLING | | MEASUREMENT | |
|--|--|--|--|
| SAMPLER: | SOLID SORBENT TUBE (carbon molecular sieve; 160 mg/80 mg) | TECHNIQUE: | GAS CHROMATOGRAPHY, FID |
| FLOW RATE: | 0.05 to 0.2 L/min | ANALYTE: | Vinyl acetate |
| VOL-MIN: | 1.5 L @ 4 ppm | DESORPTION: | 1.0 mL 95:5% (v/v) methylene chloride/methanol |
| -MAX: | 24 L | INJECTION | |
| SHIPMENT: | Routine | VOLUME: | 1 µL |
| SAMPLE STABILITY: | At least 30 days @ 5 °C | TEMPERATURE -INJECTION: | 210 °C |
| BLANKS: | 2 to 10 field blanks per set | -DETECTOR: | 260 °C |
| | | -COLUMN: | 35 °C, 5 min; 5 °C/min to 50 °C; hold 1 min |
| ACCURACY | | CARRIER GAS: | Helium, split flow 21.0 mL/min |
| RANGE STUDIED: | 3.7 to 46 mg/m ³ (24-L sample) [3] | COLUMN: | Capillary, fused silica, 30 m x 0.32 mm, coated internally with 1 µm film (5% phenyl) methylpolysiloxane |
| BIAS: | -0.04 | CALIBRATION: | Standard solutions of vinyl acetate in 95:5% (v/v) methylene chloride/methanol |
| OVERALL PRECISION ($\hat{S}_{r,T}$): | 0.064 | RANGE: | 3 to 1120 µg per sample |
| ACCURACY: | 14.1% | ESTIMATED LOD: | 1 µg per sample |
| | | PRECISION (\bar{S}_r): | 0.040 |

APPLICABILITY: The working range is 0.02 to 13.1 ppm (0.07 to 46 mg/m³) for a 24-L air sample. The method is sensitive enough for ceiling measurements.

INTERFERENCES: Vinyl acetate that is not stabilized or has been depleted of inhibitor can polymerize. Any substance collected with the vinyl acetate that is capable of reacting with it is a potential interference. Acids, bases, free radical initiators, etc., are capable of reacting with vinyl acetate during and after air sampling.

OTHER METHODS: This method is an update for NMAM 1453 first issued on August 15, 1994 [4]. This method is adapted from OSHA Method No. 51 [5] and NIOSH 1453 Issue 2 and replaces NIOSH method P&CAM 278 [6].

REAGENTS:

1. Vinyl acetate*, 99% purity, inhibited with 3 – 22 ppm hydroquinone.
2. Methanol*, distilled in glass.
3. Methylene chloride*, distilled in glass.
4. Desorption solvent, 95%/5% (v/v) methylene chloride/methanol.
5. Helium, purified.
6. Hydrogen, prepurified.
7. Air, filtered, compressed.
8. Calibration stock solution, 74.7 mg/mL. Add 400 µL vinyl acetate into a 5-mL volumetric flask and dilute to volume with methanol.

*See SPECIAL PRECAUTIONS.

EQUIPMENT:

1. Sampler: glass tube, 7 cm long, 6-mm OD, 4-mm ID, flame-sealed ends with plastic caps, containing two sections of carbon molecular sieve, (front = 160 mg, back = 80 mg) separated by a 2-mm urethane foam plug. A silylated glass wool plug precedes the front section and a 3-mm urethane foam plug follows the back section. Pressure drop across the tube at 1 L/min airflow must be less than 25 mm/Hg. Tubes are commercially available.
2. Personal sampling pump, 0.1 to 0.2 L/min, with flexible connecting tubing.
3. Gas chromatograph with flame ionization detector (GC-FID), column (page 1453-1) and data collector.
4. Vials, 2-mL, with PTFE-lined caps.
5. Syringe, 10-µL and other sizes as needed.
6. Volumetric flasks, 2- and 5-mL.

SPECIAL PRECAUTIONS: Methylene chloride is an irritant, can be absorbed through the skin, and is a potential occupational carcinogen [7]. Vinyl acetate can irritate the eyes, nose, and throat. Vinyl Acetate is flammable in air (percent by volume): lower, 2.6%; upper, 13.4% [8]. Vinyl acetate can become unstable if the polymerization inhibitor decreases to unsafe levels [8]. Methanol is flammable and a dangerous fire and explosion risk. It is moderately toxic by ingestion and inhalation. Wear appropriate protective clothing and work with these compounds in a well ventilated hood.

SAMPLING:

1. Calibrate each personal sampling pump with a representative sampler in line.
2. Break the ends of the sampler immediately before sampling. Attach sampler to personal sampling pump with flexible tubing.
3. Sample at an accurately known flow rate of 0.1 to 0.2 L/min for a total sample size of 1.5 to 24 L.
NOTE: If high concentrations are expected, multiple samplers may need to be used to collect over an 8 hour period (collect two 4-hour samples for example) in order to not exceed the capacity of the sorbent tube
4. Cap the samplers. Pack securely for shipment.

SAMPLE PREPARATION:

5. Place the front sorbent section along with the glass wool plug in a separate vial from the back sorbent section of the sampler. Discard the foam plugs.
6. Add 1.0 mL of 95:5% (v/v) methylene chloride/methanol to each vial. Cap each vial.
7. Allow to stand 30 min with occasional agitation.

CALIBRATION AND QUALITY CONTROL:

8. Calibrate daily with at least six working standards.
 - a. Add 400 µL vinyl acetate to methanol in a 5-mL volumetric flask and dilute to the mark. This is the stock calibration solution. Use serial dilutions, as needed, to obtain the desired concentration range.

- b. Analyze with samples and blanks (steps 11 and 12).
- c. Prepare calibration graph (area vs. $\mu\text{g}/\text{mL}$).
9. Determine desorption efficiency (DE) at least once for each lot of sorbent used for sampling in the range of interest (step 8). Prepare three tubes at each of five levels plus three media blanks.
 - a. Remove and discard back sorbent section of a media blank sampler.
 - b. Inject a known amount (2 to 20 μL) of a standard mixture of vinyl acetate directly onto front sorbent section with a microliter syringe.
NOTE: Inject no more than 20 μL onto the sorbent. Dilute stock solution as appropriate.
 - c. Cap the tube. Allow to stand overnight.
 - d. Desorb (steps 5 through 7) and analyze with working standards (steps 11 and 12).
 - e. Prepare a graph of DE vs. μg vinyl acetate recovered.
10. Analyze three quality control blind spikes and three analyst spikes to ensure that the calibration graph and recovery graph are in control.

MEASUREMENT:

11. Set gas chromatograph according to manufacturer's recommendations and to conditions given on page 1453-1. Inject sample aliquot manually using solvent flush technique or with autosampler.
NOTE: If peak area is above the linear range of the working standards, dilute an aliquot of the desorbed liquid with desorption solvent, reanalyze, and apply the appropriate dilution factor in calculations.
12. Measure the peak area of the vinyl acetate signal.

CALCULATIONS:

13. Determine the mass, μg (corrected for DE) of vinyl acetate found in the sample front (W_f) and back (W_b) sorbent sections, and in the average media blank front (B_f) and back (B_b) sorbent sections.
NOTE: If $W_b > W_f/10$, report breakthrough and possible sample loss.
14. Calculate concentration, C , of vinyl acetate in the air volume sampled, V (L):

$$C = \frac{(W_f + W_b) - (B_f + B_b)}{V}, \text{mg}/\text{m}^3$$

NOTE: $\mu\text{g}/\text{L} \cong \text{mg}/\text{m}^3$

EVALUATION OF METHOD:

This method was validated originally by the Organic Methods Development Branch, OSHA Technical Center, Salt Lake City, UT, over the range 187 to 710 μg per sample using Amborsorb[®] XE-347 as sorbent. Breakthrough studies at 70% RH, sampling an atmosphere of 150 mg/m^3 at 0.19 L/min, indicated a tube capacity of approximately 9 mg of vinyl acetate [5].

This media is no longer available and is replaced with Carboxen[®] 564 carbon molecular sieve tubes (OrboTM-92 or equivalent tubes). Using OrboTM-92 media, the average desorption efficiency for samples in this range was 98.5%. Recoveries from samples stored for 30 days at 5 °C were 90 to 110% for samples spiked at 187 and 747 μg per sample. The pooled coefficient of variation obtained from replicate determinations of analytical standards in this range was 0.020 [3,9].

REFERENCES:

- [1] SCOEL [2005]. Recommendation from the scientific committee on occupational exposure limits for vinyl acetate. Brussel, Belgium: Scientific Committee on Occupational Exposure Limits. [<https://ec.europa.eu/social/main.jsp?catId=148&intPagId=684&langId=en>] October 2005.
- [2] ACGIH [2014]. TLVs[®] and BEIs[®] based on the documentation of the Threshold Limit Values for chemical substances and physical agents and biological exposure indices. Cincinnati, OH: American Conference of Governmental Industrial Hygienists [<http://www.acgih.org/>].
- [3] NIOSH [2013]. Backup data report for vinyl acetate. Cincinnati, OH: U.S. Department of Health and Human Services, Centers for Disease Control and Prevention, National Institute for Occupational Safety and Health (unpublished).
- [4] NIOSH [1994]. Vinyl acetate: Method 1453. In: Eller PM, Cassinelli ME, eds. NIOSH manual of analytical methods, 4th ed. Cincinnati, OH: U.S. Department of Health and Human Services, Centers for Disease Control and Prevention, National Institute for Occupational Safety and Health, DHHS (NIOSH) Publication No. 94-113 [www.cdc.gov/niosh/nmam/].
- [5] OSHA [1985]. Vinyl acetate: OSHA Method ORG-51. Salt Lake City, Utah: U.S. Department of Labor, Occupational Safety and Health Administration. [<http://www.osha.gov/dts/sltc/methods/organic/org051/org051.html>]. Date accessed October 2012.
- [6] NIOSH [1978]. Vinyl acetate: P & CAM 278. In: Taylor DG, ed. NIOSH manual of analytical methods, 2nd ed., Vol 4. Cincinnati, OH: U.S. Department of Health, Education, and Welfare, Center for Disease Control, National Institute for Occupational Safety and Health, DHEW (NIOSH) Publication No. 78-175.
- [7] NIOSH [2005]. NIOSH pocket guide to chemical hazards. Barsan ME, ed. Cincinnati OH: U.S. Department of Health and Human Services, Centers for Disease Control and Prevention, National Institute for Occupational Safety and Health, DHHS (NIOSH) Publication No. 2005-149.
- [8] Gustin J-L [2005]. Understanding vinyl acetate polymerization accidents. *Chem Health Saf* 12(6):36-46.
- [9] Yoon YH, Perkins JB [1998]. Vinyl acetate by GC-FID sample analysis backup data report. Salt Lake City, UT: DataChem Laboratories. Developed under NIOSH contract CDC-200-2001-08000 (unpublished).

METHOD REVISED BY:

3rd Issue (2013) Y. T. Gagnon and P. F. O'Connor, CDC/NIOSH, Cincinnati, Ohio.

2nd Issue (1998) Y. H. Yoon, Ph.D. and J. B. Perkins, DataChem Laboratories, Inc., Salt Lake City, Utah.

1st Issue (1994) A. A. Grote, CDC/NIOSH, Cincinnati, Ohio.

Disclaimer: Mention of any company or product does not constitute endorsement by NIOSH. In addition, citations to websites external to NIOSH do not constitute NIOSH endorsement of the sponsoring organizations or their programs or products. Furthermore, NIOSH is not responsible for the content of these websites. All web addresses referenced in this document were accessible as of the publication date.



NITROAROMATIC COMPOUNDS

2005

| | | | |
|---|----------------|------------------|----------------------|
| (1) Nitrobenzene: C ₆ H ₅ NO ₂ | MW: (1) 123.11 | CAS: (1) 98-95-3 | RTECS: (1) DA6475000 |
| (2) <i>o</i> -Nitrotoluene: CH ₃ C ₆ H ₄ NO ₂ | (2) 137.14 | (2) 88-72-2 | (2) XT3150000 |
| <i>m</i> -Nitrotoluene: | | 99-08-1 | XT2975000 |
| <i>p</i> -Nitrotoluene: | | 99-99-0 | XT3325000 |
| (3) 4-Chloronitrobenzene: C ₆ H ₄ ClNO ₂ | (3) 157.56 | (3) 100-00-5 | (3) CZ1050000 |

METHOD: 2005, Issue 4

EVALUATION: FULL

Issue 1: 15 August 1990

Issue 4: 4 March 2016

OSHA: Table 1

PROPERTIES: Table 1

NIOSH: Table 1

SYNONYMS: (1) Nitrobenzol, oil of mirbane; (2) *o*-Methylnitrobenzene, 2-Methylnitrobenzene, 2-Nitrotoluene *m*-Methylnitrobenzene, 3-Methylnitrobenzene, 3-Nitrotoluene *p*-Methylnitrobenzene, 4-Methylnitrobenzene, 4-Nitrotoluene; (3) *p*-Chloronitrobenzene, 1-Chloro-4-nitrobenzene, 4-Nitrochlorobenzene, PCNB, PNCB

| SAMPLING | | MEASUREMENT | |
|--|---|--|--|
| SAMPLER: | SOLID SORBENT TUBE (silica gel, 150 mg/75 mg) | TECHNIQUE: | GAS CHROMATOGRAPHY, FID |
| FLOW RATE: | (1) and (3) 0.01 - 1 L/min; (2) 0.01 to 0.02 L/min | ANALYTE: | nitrobenzene, nitrotoluene isomers, 4-chloronitrobenzene |
| VOL-MIN: | (1) 10 L (2) 1L (3) 1L | DESORPTION: | 1 mL methanol in ultrasonic bath for 30 minutes mL acetonitrile |
| -MAX: | 150 L 30L 150L | INJECTION VOLUME: | 1 µL |
| SHIPMENT: | routine | TEMPERATURE | |
| SAMPLE STABILITY: | 30 days @ 0 °C [1] | -INJECTION: | 250 °C |
| BLANKS: | 2 to 10 field blanks per set | -DETECTOR: | 300 °C |
| | | -COLUMN: | 80 °C, 1 min, 8 °C/min to 180 °C |
| | | CARRIER GAS: | He, 2.5 to 3.0 mL/min |
| | | COLUMN: | capillary, 30 m x 0.53-mm ID; µm film crossbonded 5% diphenyl 95% dimethylpolysiloxane |
| | | CALIBRATION: | analytes in methanol |
| | | RANGE: | Table 1 |
| | | ESTIMATED LOD: | Table 1 |
| | | PRECISION (\bar{S}_r): | Table 1 |
| ACCURACY | | | |
| RANGE STUDIED: | Table 1 | | |
| BIAS: | Table 1 | | |
| OVERALL PRECISION ($\hat{S}_{r,T}$): | Table 1 | | |
| ACCURACY: | Table 1 | | |

APPLICABILITY: The working ranges for a 30-L air samples are 0.396 to 1.92 ppm (1.98 to 9.60 mg/m³) for nitrobenzene; 0.346 to 1.73 ppm (1.97 to 9.86 mg/m³) for *o*-nitrotoluene; 0.344 to 1.72 ppm (1.96 to 9.81 mg/m³) for *m*-nitrotoluene; 0.303 to 1.52 ppm (1.73 to 8.67 mg/m³) for *p*-nitrotoluene; and 0.308 to 1.54 ppm (1.98 to 9.92 mg/m³) for 4-chloronitrobenzene [1,2].

INTERFERENCES: Any compounds with retention times similar to the analytes of interest will interfere. During sampling, high humidity may greatly decrease breakthrough volume

OTHER METHODS: This method is an update of NMAM 2005, Nitrobenzenes, issued 15 August 1994, which combined and replaced methods S217, S218, and S223 [2,3].

REAGENTS:

1. Methanol, HPLC chromatographic grade.
2. Nitrobenzene*, reagent grade.
3. *o*-,*m*-,*p*-nitrotoluene isomers,* reagent grade.
4. 4-chloronitrobenzene*, reagent grade.
5. Calibration stock solution, 500 µg/mL.
Prepare each analyte in methanol.
6. Helium, purified and filtered.
7. Hydrogen, purified and filtered.
8. Air, purified and filtered.

*See SPECIAL PRECAUTIONS.

EQUIPMENT:

1. Sampler: silica gel sampling tube; glass tube, 7 cm long, 6-mm OD, 4-mm ID, flame-sealed ends with plastic caps, containing two sections (front=150 mg; back=75 mg) of 20/40 mesh silica gel separated by a 2-mm urethane foam plug. A silylated glass wool plug precedes the front section and a 3-mm urethane foam plug follows the back section.
2. Personal sampling pump, 0.01 to 1 L/min, with flexible connecting tubing.
3. Gas chromatograph, FID, integrator and column (page 2005-1).
4. Autosampler vials, glass, 2-mL, with PTFE-lined crimp caps.
5. Volumetric flasks, 10-mL.
6. Pipets, 5-mL and 3-mL, with pipet bulb.
7. Syringes, 10-µL, 100-µL, and 1-mL.
8. Ultrasonic bath.

SPECIAL PRECAUTIONS: These analytes are severe poisons and irritants. Prevent contact with eyes, skin, or clothing by wearing eye protection, chemically resistant gloves, and a lab coat. Avoid inhalation. Nitrobenzene and *m*-nitrotoluene are absorbed through contact with skin and can cause methemoglobinemia [5,6]. 4-Chloronitrobenzene is a carcinogen. Methanol is highly flammable.

SAMPLING:

1. Calibrate each personal sampling pump with a representative sampler in line.
2. Break the ends of the sampler immediately before sampling. Attach sampler to personal sampling pump with flexible tubing.
3. Sample at an accurately known flow rate between 0.01 and 0.2 L/min for nitrotoluene isomers. Use a flow rate of 1 L/min or less for nitrobenzene and 4-chloronitrobenzene. Note the maximum and minimum sample volumes on page 2005-1.
4. Cap both ends of the sampler. Pack securely for shipment.

SAMPLE PREPARATION:

5. Place the front (include the glass wool plug) and back sorbent sections of each sample tube in separate vials. Discard the foam plugs.
6. Add 1.0 mL of methanol to each vial. Attach crimp cap securely to each vial.
7. Allow to desorb 30 min in an ultrasonic bath.

CALIBRATION AND QUALITY CONTROL:

8. Calibrate daily with at least six working standards to cover the analytical range of the method. If necessary, additional standards may be added to extend the calibration curve.
 - a. Add known amounts of calibration stock to methanol in 10-mL volumetric flasks and dilute to the mark.
 - b. Analyze together with samples and blanks (steps 11 and 12).
 - c. Prepare calibration graph (peak area vs μg analyte).
9. Determine desorption efficiency (DE) at least once for each lot of silica gel used for sampling in the calibration ranges (step 8).
 - a. Prepare three tubes at each of five levels plus three media blanks.
 - b. Inject a known amount of calibration stock solution directly onto the front sorbent section of each silica gel tube with a microliter syringe.
 - c. Allow the tubes to air equilibrate for several minutes, then cap the ends of each tube and allow to stand overnight.
 - d. Desorb (steps 5 through 7) and analyze together with standards and blanks (steps 11 and 12).
 - e. Prepare a graph of DE vs μg analyte recovered.
10. Analyze three quality control blind spikes and three analyst spikes to ensure that the calibration graph and DE graph are in control.

MEASUREMENT:

11. Set gas chromatograph according to manufacturer's recommendations and to conditions given on page 2005-1. Inject a 1- μL sample aliquot manually using the solvent flush technique or with an autosampler.
NOTE: If peak area is above the linear range of the working standards, dilute with methanol, reanalyze and apply the appropriate dilution factor in the calculations.
12. Measure peak areas.

CALCULATIONS:

13. Determine the mass, μg (corrected for DE) of analyte found in the sample front (W_f) and back (W_b) sorbent sections, and in the average media blank front (B_f) and back (B_b) sorbent sections.
NOTE: If $W_b > W_f/10$, report breakthrough and possible sample loss.
14. Calculate concentration, C , of analyte in the air volume sampled, $V(L)$:

$$C = \frac{W_f + W_b - B_f - B_b}{V}, \text{mg/m}^3$$

NOTE: $\mu\text{g/mL} \cong \text{mg/m}^3$

EVALUATION OF METHOD:

The 3rd issue update of this method included the use of capillary column chromatography (Rtx™-5 Amine) that lowered the LOD/LOQ values, a lower 5-level desorption efficiency study, and a 30-day storage stability study for each analyte [1]. The method evaluation data for these compounds are listed in Table 2. Methods S217, Nitrobenzene, and S218, 4-nitrochlorobenzene, were initially issued on November 21, 1975 [4]. Method S223, *o*-nitrotoluene was issued on December 19, 1975 [4]. The analytes *m*-nitrotoluene and *p*-nitrotoluene were added on May 15, 1984 [3]. In the original method development work, sample tube capacity, or breakthrough, was determined as 5% of the generated atmosphere concentration as measured in the effluent of the sample tubes. Capacity was measured at >2.8 mg/sample for nitrobenzene; >2.5 mg/sample for nitrotoluene isomers; and >2.2 mg/sample for 4-chlorobenzene [2].

REFERENCES:

- [1] Pendergrass SM [1997]. Backup data report for nitroaromatic compounds method development. Cincinnati, OH: National Institute for Occupational Safety and Health. Unpublished.
- [2] NIOSH [1977]. Methods S217, S218, and S223. In: Documentation of the NIOSH validation tests. Cincinnati, OH: U.S. Department of Health, Education, and Welfare, Center of Disease Control and Prevention, National Institute for Occupational Safety and Health, DHEW (NIOSH) Publication No. 77-185.
- [3] NIOSH [1994]. *m*-Nitrotoluene and *p*-Nitrotoluene: Method 2005. In: Eller PM, Cassinelli ME, eds. NIOSH manual of analytical methods, 4th ed. Cincinnati, OH: U.S. Department of Health and Human Services, Centers for Disease Control and Prevention, National Institute for Occupational Safety and Health, DHHS (NIOSH) Publication No. 94-113.
- [4] NIOSH [1978]. Nitrobenzene: Method S217; *p*-Nitrochlorobenzene: Method S218; and Nitrotoluene: Method S223. In: Taylor DG, ed. NIOSH manual of analytical methods. 2nd ed. Cincinnati, OH: U.S. Department of Health, Education, and Welfare, Center for Disease Control, National Institute for Occupational Safety and Health, DHEW (NIOSH) Publication No. 77-157-C.
- [5] NIOSH [1977]. Aromatic hydrocarbons and nitrobenzene. In: Key MM, Henschel AF, Butler J, Ligo RN, Tabershaw IR, Ede L, eds. Occupational diseases: A guide to their recognition. revised ed. Cincinnati, OH: U.S. Department of Health, Education, and Welfare, Center for Disease Control, National Institute for Occupational Safety and Health, DHEW (NIOSH) Publication No. 77-181.
- [6] NIOSH [1981]. Occupational health guidelines for chemical hazards, nitrobenzene, nitrochlorobenzene and nitrotoluene, U.S. Department of Health and Human Services, Centers for Disease Control, National Institute for Occupational Safety and Health, DHHS (NIOSH) Publication No. 81-123.

METHOD WRITTEN BY:

Stephanie M. Pendergrass, NIOSH

TABLE 1. General Information

| Chemical | OSHA PEL | NIOSH REL | Physical Properties | Method Evaluation |
|------------------------|---|--|--|-------------------|
| Nitrobenzene | 1 ppm (5 mg/m ³) (skin) | 1 ppm (5 mg/m ³) (skin) | Colorless oily liquid, almond odor; d=1.196 g/mL @ 20 °C; MP 6 °C; BP 210- 211 °C; VP=37 Pa (0.30 mm Hg) @ 20 °C | Full |
| <i>o</i> -Nitrotoluene | 5 ppm (30 mg/m ³) (skin) | 2 ppm (11 mg/m ³) (skin) | yellowish liquid; d=1.163 g/mL @ 20 °C; MP -4 °C; BP 222 °C; VP=20 Pa (0.15 mm Hg) @ 20 °C | Full |
| <i>m</i> -Nitrotoluene | 5 ppm (30 mg/m ³) (skin) | 2 ppm (11 mg/m ³) (skin) | liquid; d=1.157 g/mL @ 20 °C; MP 16 °C; BP 232 °C; VP=20 Pa (0.15 mm Hg) @ 20 °C | Partial |
| <i>p</i> -Nitrotoluene | 5 ppm (30 mg/m ³) (skin) | 2 ppm (11 mg/m ³) (skin) | yellow crystals; d=1.163 g/mL @ 20 °C; MP 52 °C; BP 238 °C; VP=17 Pa (0.12 mm Hg) @ 20 °C | Partial |
| 4-Chloro-nitrobenzene | 0.16 ppm (1. mg/m ³) (skin) | Ca* (skin) | yellow crystals; d=1.298 g/mL @ 20 °C; MP 83 °C; BP 242 °C; VP=28 Pa (0.2 mm Hg) @ 30 °C | Partial |

* - Cancer suspect agent

TABLE 2. Method Summary

| Chemical | Range Studied (mg/m ³) | \hat{S}_{RT} | Bias | Accuracy ($\pm\%$) | Analytical Range | LOD ($\mu\text{g}/\text{sample}$) | \bar{S}_r | Desorption Efficiency (%) | 30-Day Storage (% Rec) |
|------------------------|------------------------------------|-----------------|--------|----------------------|------------------|-------------------------------------|-------------|---------------------------|------------------------|
| Nitrobenzene | 1.98-9.60 | 0.0590 | 0.0186 | 12.3 | 2 to 598 | 0.6 | 0.12 | 98.7 | 100.2 |
| <i>o</i> -Nitrotoluene | 1.97-9.86 | 0.0142 | -0.120 | 21.1 | 3 to 582 | 0.8 | 0.028 | 98.2 | 101.2 |
| <i>m</i> -Nitrotoluene | Not studied | nd ^b | nd | nd | 3 to 579 | 1.0 | 0.042 | 97.5 | 99.4 |
| <i>p</i> -Nitrotoluene | Not studied | nd | nd | nd | 9 to 511 | 2.6 | 0.061 | 96.9 | 99.4 |
| 4-Chloro-nitrobenzene | 1.98-9.92 | 0.1034 | 0.0869 | 27.3 ^c | 8 to 595 | 2.5 | 0.063 | 100.3 | 97.6 |

^a30-L air sample^b Not determined^c Exceeds the NIOSH accuracy criterion of $\pm 25\%$ at the 95% confidence level

Disclaimer: Mention of any company or product does not constitute endorsement by NIOSH. In addition, citations to websites external to NIOSH do not constitute NIOSH endorsement of the sponsoring organizations or their programs or products. Furthermore, NIOSH is not responsible for the content of these websites. All web addresses referenced in this document were accessible as of the publication date.



CHLOROACETIC ACID

2008

ClCH2COOH

MW: 94.50

CAS: 79-11-8

RTECS: AF8575000

METHOD: 2008, Issue 3

EVALUATION: FULL

Issue 1: 15 May 1989

Issue 3: 15 March 2016

OSHA: None
NIOSH: None

PROPERTIES: solid; MP 61 to 63 °C; BP 189 °C;
VP 0.1 kPa (0.75 mm Hg) @ 20 °C; flash
point 126 °C; lower explosive limit in
air 8% v/v

SYNONYMS: chloroethanoic acid; monochloroacetic acid

| SAMPLING | | MEASUREMENT | |
|---|---|--|---|
| SAMPLER: | SOLID SORBENT TUBE (silica gel, 100 mg/50 mg) | TECHNIQUE: | ION CHROMATOGRAPHY, CONDUCTIVITY DETECTION |
| FLOW RATE: | 0.05 to 0.2 L/min | ANALYTE: | chloroacetate ion |
| VOL-MIN: | 1 L @ 0.25 ppm | DESORPTION: | 2 mL deionized water |
| -MAX: | 100 L | INJECTION LOOP VOLUME: | 500 µL |
| SHIPMENT: | routine | ELUENT: | 1.5 mM NaHCO ₃ ; 1.0 mL/min |
| SAMPLE STABILITY: | at least 7 days @ 25 °C; 32 days refrigerated [1] | COLUMNS: | US Pharmacopeia (USP) L12 separator column and manufacturer's compatible anion guard column |
| BLANKS: | 2 to 10 field blanks per set | CALIBRATION: | standard solutions of chloroacetic acid in deionized water |
| ACCURACY | | RANGE: | 1 to 80 µg per sample [1] |
| RANGE STUDIED: | 0.35 to 29 mg/m ³ [1,2] (3-L samples) | ESTIMATED LOD: | 0.04 µg per sample [2] |
| BIAS: | 2.0% | PRECISION (\bar{S}_r): | 0.016 [1] |
| OVERALL PRECISION (\hat{S}_{rT}): | 0.08 [1] | | |
| ACCURACY: | ± 17.7% | | |

APPLICABILITY: The working range is 0.09 to >85 ppm (0.3 to 30 mg/m³) for a 3-L air sample.

INTERFERENCES: Chloroacetyl chloride is a positive interferent since it is hydrolyzed to monochloroacetic acid by the measurement procedure and is efficiently collected by silica gel [3]. Particulate salts of the acid are positive interferents. The chromatographic conditions given will separate acetate, chloride, dichloroacetate, fluoride, glycolate, and trichloroacetate ions from chloroacetate ion.

OTHER METHODS: This revises P&CAM 332 [2]. The columns used in P&CAM 332 are no longer available. The newer columns indicated here show improvements in the analytical range and sensitivity.

REAGENTS:

1. Water, filtered, deionized. Specific conductance $\leq 10 \mu\text{S}/\text{cm}$.
2. Sodium bicarbonate (NaHCO_3), reagent grade.
3. Chloroacetic acid, $\geq 99\%$.*
4. Eluent: 1.5 mM NaHCO_3 . Dissolve 0.504 g NaHCO_3 in 4 L filtered, deionized water.
5. Calibration stock solution, 1000 $\mu\text{g}/\text{mL}$. Dissolve 100 mg chloroacetic acid in 100 mL filtered, deionized water.

*See SPECIAL PRECAUTIONS.

EQUIPMENT:

1. Sampler: silica gel sorbent tube; glass tube, 7 cm long, 6-mm OD, 4-mm ID, with plastic caps, containing two sections of 20/40 mesh silica gel (front = 100 mg; back = 50 mg) contained and separated by three silanized glass wool plugs. Pressure drop across the tube at 0.2 L/min is ca. 0.6 kPa (2.6 in. H_2O). Tubes are commercially available.
NOTE: Chloroacetic acid is irreversibly adsorbed on urethane plugs. Use sorbent tubes with glass wool plugs.
2. Personal sampling pump, 0.05 to 0.2 L/min, with flexible connecting tubing.
3. Ion chromatograph (IC), anion separator (USP L12) and compatible guard column, anion suppressor (page 2008-1), conductivity detector and integrator.
4. Ultrasonic bath.
5. Vials, 20-mL, glass, with aluminum-lined plastic screw caps.
6. Syringes, 3-mL, polyethylene with luer tip.
7. Filter holder, luer tip, 13-mm, with polytetrafluoroethylene (PTFE) filter, 5- μm pore size, or PTFE syringe filter.
8. Pipets, 10- μL to 2-mL.
9. Flasks, volumetric, 10- and 100-mL.

SPECIAL PRECAUTIONS: Chloroacetic acid is irritating to skin and mucous membranes [4]. Work with concentrated material only in a hood.

SAMPLING:

1. Calibrate each personal sampling pump with a representative sampler in line.
2. Break ends of sampler immediately before sampling. Attach sampler to personal sampling pump with flexible tubing.
3. Sample at an accurately known flow rate between 0.05 to 0.2 L/min for a total sample size of 1 to 100 L.
4. Cap the samplers. Pack securely for shipment.

NOTE: Store samples in the dark. Refrigerate samples if stored longer than 7 days.

SAMPLE PREPARATION:

5. Allow refrigerated samples to equilibrate to room temperature.
6. Transfer front sorbent section with front glass wool plug to vial. Place back sorbent section and other two glass wool plugs in separate vial.
7. Add 2.0 mL deionized water to each vial. Cap immediately.
8. Agitate vials in ultrasonic bath for 30 min at room temperature.
9. Draw sample extract through 13-mm PTFE filter with 3-mL syringe.

CALIBRATION AND QUALITY CONTROL:

10. Calibrate daily with at least six working standards.
 - a. Add known aliquots of calibration stock solution to deionized water in 10-mL volumetric flasks and dilute to the mark. Use serial dilutions as needed to obtain chloroacetic acid concentrations in the range 0.02 to 40 µg/mL.
 - b. Analyze together with samples and blanks (steps 13 through 15).
 - c. Prepare calibration graph [peak height (mm or µS) vs. µg chloroacetic acid per sample].
11. Determine desorption efficiency (DE) for each batch of silica gel used for sampling in the calibration range. Prepare at least three tubes at each of five levels.
 - a. Place silica gel from unused front section in vial.
 - b. Inject a known amount (2 to 20 µL) of calibration stock solution, or a serial dilution thereof, onto front sorbent section with a microliter syringe.
 - c. Cap the vial. Allow to stand overnight.
 - d. Desorb (steps 7 through 9) and analyze together with working standards (steps 13 through 15).
 - e. Prepare graph of DE vs. µg chloroacetic acid recovered.
12. Analyze three quality control spikes and three analyst spikes to ensure that the calibration graph and DE graph are in control.

MEASUREMENT:

13. Set ion chromatograph according to manufacturer's recommendations and to conditions given on page 2008-1.
14. Inject sample aliquot manually or use autosampler.
 - a. Flush sample loop with 0.5 mL sample extract, then inject 0.5 mL sample.
 - b. Rinse sample loop with 1 to 2 mL deionized water between determinations of separate samples.
NOTE: All samples, eluents, and water flowing through the IC must be filtered to avoid plugging the system valves or columns.
15. Measure peak height.
NOTE: If sample peak height exceeds linear calibration range, dilute with deionized water, reanalyze, and apply appropriate dilution factor.

CALCULATIONS:

16. Determine mass, µg (corrected for DE), of analyte found in the sample front (W_f) and back (W_b) sorbent sections, and in the average media blank front (B_f) and back (B_b) sorbent sections.
17. Calculate concentration, C , of chloroacetic acid in the air volume sampled, V (L):

$$C = \frac{W_f + W_b - B_f - B_b}{V} \text{ mg/m}^3$$

EVALUATION OF METHOD:

This method was developed and evaluated by Southern Research Institute [1] using dynamically-generated atmospheres of chloroacetic acid over the concentration range of 0.35 to 29 mg/m³ at 25 to 27 °C and at relative humidity (RH) ≥80%. Average recovery based on 18 samples, six at each of three levels, was 98% representing a negligible bias. Precision at 0.35 mg/m³ was inhomogeneous with those of higher levels; therefore, precisions were not pooled. Using this poorest precision ($\bar{S}_r = 0.064$), the overall precision (\hat{S}_{rT}) was estimated to be ≤0.081.

The breakthrough volume of the 100-mg sorbent section was found to be >100 L at 0.2 L/min when sampling chloroacetic acid concentrations of 60 mg/m³ at 42 °C and RH of 10 and 80% and 35 mg/m³ at 27 °C and 10 and 90% RH. Samples stored at ambient temperature for 7 days had a mean recovery of 91%

and a precision, \bar{S}_r , of 0.047. Samples refrigerated after day 7, and stored for 32 days exhibited a mean recovery of 100% with a precision, \bar{S}_r , of 0.085 based on samples analyzed on day 1.

REFERENCES:

- [1] Dillon HK, Mason DW, Boyd KW [1980]. Development of air sampling and analytical methods for toxic chlorinated organic compounds: research report for monochloroacetic acid. Birmingham, AL: Southern Research Institute. NIOSH contract no. 210-78-0012. Unpublished.
- [2] NIOSH [1980]. Chlorine: Method P&CAM 322. In: Taylor DG, ed. NIOSH manual of analytical methods. 2nd ed. Cincinnati, OH: U.S. Department of Health, Education, and Welfare, Center for Disease Control, National Institute for Occupational Safety and Health, DHEW (NIOSH) Publication No. 80-125.
- [3] McCullough PR, Worley JW [1979]. Sampling of chloroacetyl chloride in air on solid support and determination by ion chromatography. *Anal Chem* 51:1120-1122.
- [4] Budavari S, ed. [1989]. Merck Index, 11th ed. Rahway, NJ: Merck and Co.

METHOD REVISED BY:

Mary Ellen Cassinelli, NIOSH

Disclaimer: Mention of any company or product does not constitute endorsement by NIOSH. In addition, citations to websites external to NIOSH do not constitute NIOSH endorsement of the sponsoring organizations or their programs or products. Furthermore, NIOSH is not responsible for the content of these websites. All web addresses referenced in this document were accessible as of the publication date.

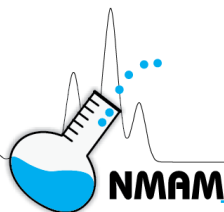

p-CHLOROPHENOL

2014

C₆H₄ClO

MW: 128.56

CAS: 106-48-9

RTECS: SK2800000

METHOD: 2014, Issue 2

EVALUATION: FULL

Issue 1: 19 September 1980

Issue 2: 25 February 2016

OSHA: None

NIOSH: None

PROPERTIES: crystals; d 1.224 g/mL @ 20 °C; MP 43.2-43.7 °C; BP 220 °C; VP 0.013 kPa (0.1 mm Hg) @ 20 °C; flash point 121 °C (closed cup)

SYNONYMS: 4-chlorophenol; 4-chloro-1-hydroxybenzene

| SAMPLING | | MEASUREMENT | |
|--|---|--|---|
| SAMPLER: | SORBENT TUBE (silica gel, 150 mg/75 mg) | TECHNIQUE: | HPLC/UV |
| FLOW RATE: | 0.05 - 0.2 L/min | ANALYTE: | <i>p</i> -chlorophenol |
| VOL-MIN: | 1.5 L @ 1 ppm | EXTRACTION: | 1 mL acetonitrile |
| -MAX: | 40 L | MOBILE PHASE: | 30% acetonitrile, 70% water to 80% acetonitrile/20% water in 20 minutes, 1 mL/min |
| SHIPMENT: | routine | COLUMN: | C18 (5 μm particle size, 4-mm ID by 30-cm long, stainless steel) |
| SAMPLE STABILITY: | 7 days @ 25 °C at least 29 days @ 0 °C [1] | DETECTOR: | UV @ 280 nm |
| BLANKS: | 2 to 10 field blanks per set | CALIBRATION: | <i>p</i> -chlorophenol in 30% (v/v) acetonitrile in water |
| ACCURACY | | RANGE: | 8 to 64 μg/sample [1] |
| RANGE STUDIED: | 0.910 to 23.4 mg/m ³ [1] (3-L samples) | ESTIMATED LOD: | 2.5 μg/sample [1] |
| BIAS: | none identified | PRECISION (\bar{S}_r): | 0.024 [1] |
| OVERALL PRECISION ($\hat{S}_{r,T}$): | 0.061 for range studied [1] | | |
| ACCURACY: | ± 15% (12-28%) | | |

APPLICABILITY: The working range is 0.15 to 53 ppm (0.8 to 280 mg/m³) for a 10-L air sample.

INTERFERENCES: None identified. The chromatographic conditions described will separate phenol; *o*-chlorophenol; 2,3-, 2,4-, 2,5-, 2,6-, 3,4-, and 3,5- dichlorophenol; *o*- and *p*-nitrophenol; 2,4-dimethylphenol; 2,4,5-trichlorophenol; 4-chloro-*o*-methylphenol; 2,4-dinitrophenol; 4,6-dinitro-2-methylphenol; and pentachlorophenol.

OTHER METHODS: This method replaces P&CAM 337 [2]. The other columns for the analysis of *p*-chlorophenol have been reported in the literature [3-5].

REAGENTS:

1. *p*-Chlorophenol 99%.*
2. Acetonitrile, distilled in glass.
3. Hexane, distilled in glass.
4. Water, HPLC quality distilled, deionized.
5. *p*-Chlorophenol stock solution, 20 mg/mL.
Dissolve 500 mg *p*-chlorophenol in 30% (v/v) acetonitrile in water to make 25 mL solution. Stable at least 3 months in airtight container.
6. Desorption efficiency (DE) stock solution, 5 mg/mL. Dissolve 125 mg *p*-chlorophenol in hexane to make 25 mL solution.

*See SPECIAL PRECAUTIONS.

EQUIPMENT:

1. Sampler: borosilicate glass tubes, 7 cm long with a 6-mm OD and a 4-mm ID, flame sealed at both ends. Each tube contains two sections of 20/40 mesh silica gel (a 150-mg sorbent section and a 75-mg backup section separated and held in place with glass wool plugs). Tubes are commercially available.
2. Personal sampling pump, calibrated, capable of operating 8 hours at 0.05 to 0.2 L/min with flexible connecting tubing.
3. HPLC with UV detector (280 nm), C18 column, injector, and electronic integrator.
4. Microliter syringes, various sizes.
5. Volumetric flasks, various sizes.
6. Centrifuge tubes, 12-mL, glass with screw caps.
7. Pipette, 1- and 2-mL, and convenient sizes for making dilutions.
8. Vials, 1-mL, with caps containing PTFE-lined silicone septa.
9. Ultrasonic bath.

SPECIAL PRECAUTIONS: *p*-Chlorophenol is toxic by skin absorption, inhalation, or ingestion. It also is a strong irritant to tissue and is combustible with a flash point of 121 °C.

SAMPLING:

1. Calibrate each personal sampling pump with a representative sampler in line.
2. Immediately before sampling, break open the ends of the tube to provide openings that are at least 2-mm in diameter. Attach sampler to personal sampling pump with flexible tubing.
3. Sample at an accurately known flowrate between 0.05 and 0.2 L/min for a total sample size of 1 to 40 liters.
4. Cap the tubes, record sample identity and all relevant sample data (duration, ambient temperature and pressure). Pack securely for shipment.
NOTE: Refrigerate all samples at 0 °C when stored longer than 7 days.

SAMPLE PREPARATION:

5. If refrigerated, allow tube to equilibrate to room temperature.
6. Transfer each section of silica gel in a sorbent tube to a separate 12-mL centrifuge tube. Combine the glass wool plug near the inlet with the front sorbent section. Combine the two urethane foam plugs with the back section.
7. Add 1 mL of acetonitrile, cap, and desorb in an ultrasonic bath for 30 minutes.
8. Add 2 mL of distilled, deionized water to each tube, cap, and mix the solutions.
9. Centrifuge the samples and transfer about 1 mL of the supernatant in each tube to a separate vial and seal with a PTFE-lined septum.

CALIBRATION AND QUALITY CONTROL:

10. Calibrate daily with at least six working standards in the range 2.5 to 64 µg per sample.
 - a. Dilute aliquots of *p*-chlorophenol stock solution with 30% (v/v) acetonitrile in water in volumetric flasks to encompass the range of interest. Prepare fresh daily.
 - b. Analyze working standards with samples and blanks steps.
 - c. Prepare calibration graph (peak area or peak height vs. µg of *p*-chlorophenol per sample).
11. Determine desorption efficiency (DE) for each lot of silica gel used for sampling in the calibration range. Prepare three tubes at each of five levels.
 - a. Remove backup section. Inject known amounts of DE stock solution (2 to 10 µL) onto the silica gel with a microliter syringe.
 - b. Cap the tubes and allow to stand overnight.
 - c. Desorb (steps 7 through 9) and analyze together with standards and blanks (steps 13 and 14).
 - d. Prepare a graph DE vs. µg *p*-chlorophenol recovered.
12. Analyze three quality control spikes and three analyst spikes to ensure that the calibration graph and DE graph are in control.

MEASUREMENT:

13. Set HPLC according to manufacturer's recommendations and to conditions on page 2014-1. Inject sample aliquot manually or with autosampler.
NOTE: If peak is above the linear range of the working standards, dilute with 30% (v/v) acetonitrile in water, reanalyze, and apply the appropriate dilution factor.
14. Measure peak area or peak height.

CALCULATIONS:

15. Determine the mass, µg (corrected for DE), of analyte found on the sample front (W_f) and back (W_b) sorbent sections, and in the average media blank front (B_f) and back (B_b) sorbent sections.
16. Calculate concentration of *p*-chlorophenol in the air volume sampled, V (L):

$$C = \frac{W_f + W_b - B_f - B_b}{V}, \text{ mg/m}^3$$

EVALUATION OF METHOD:

The overall method was evaluated by collecting 3-L samples of test atmospheres containing *p*-chlorophenol in the range of 0.91 - 23.4 mg/m³ at 29 °C and a relative humidity of greater than 80%. The amounts collected ranged from 2.6 - 64 µg per 150-mg bed of silica gel. The breakthrough volume of the sorbent tube was found to be approximately 60 L with a sampling rate of 0.2 L/min at a *p*-chlorophenol concentration of about 70 mg/m³, a sampling temperature of 43 °C, and a relative humidity of greater than 80%. Samples of *p*-chlorophenol on silica gel were found to be stable at 25 °C for 7 days and for 29 days if stored at 0 °C after the seventh day. Silica gel gave an average desorption efficiency of 96% with a \bar{S}_r 2.4% for loadings of 2.54 - 48.0 µg of *p*-chlorophenol on 150-mg beds of sorbent material.

REFERENCES:

- [1] Dillon HK, Emory MB [1980]. Development of air sampling and analytical methods for toxic chlorinated organic compounds: Research report for *p*-chlorophenol. NIOSH contract no. 210-78-0012. Birmingham, AL. Southern Research Institute.
- [2] NIOSH [1981]. *P*-Chlorophenol: P&CAM 337. In: Taylor DG, ed. NIOSH manual of analytical methods. 2nd ed. Cincinnati, OH: U.S. Department of Health and Human Services, Center for Disease Control, National Institute for Occupational Safety and Health, DHHS (NIOSH) Publication No. 82-100.
- [3] Korhonen IO [1980]. Separation of chlorophenol isomers on quartz columns. *J Chromatogr* 303(1):197-205.
- [4] Buisson RSK, Kirk PWW, Lester JN [1984]. Determination of chlorinated phenols in water, wastewater and sludge by capillary GC/ECD. *J Chromatogr Sci* 22(8):399-42.
- [5] Lee HB, Hong-You RL, Fowlie PJ [1989]. Chemical derivatization analysis of phenols. Part VI. Determination of chlorinated phenolics in pulp and paper effluents. *J Assoc Off Anal Chem* 72(6):979-984.

METHOD REVISED BY:

Charles Neumeister, NIOSH.

Disclaimer: Mention of any company or product does not constitute endorsement by NIOSH. In addition, citations to websites external to NIOSH do not constitute NIOSH endorsement of the sponsoring organizations or their programs or products. Furthermore, NIOSH is not responsible for the content of these websites. All web addresses referenced in this document were accessible as of the publication date.



FORMALDEHYDE

2016

H₂C=O

MW: 30.03

CAS: 50-00-0

RTECS: LP8925000

METHOD: 2016, Issue 3

EVALUATION: FULL

Issue 1: 15 January 1998

Issue 3: 25 February 2016

OSHA: 0.75 ppm; 2 ppm STEL
NIOSH: 0.016 ppm; C 0.1 ppm; carcinogen
 (1 ppm = 1.23 mg/m³ @ NTP)

PROPERTIES: Gas; BP -19.5 °C; specific gravity 1.067 (air = 1);
 explosive range 7 to 73% (v/v) in air

SYNONYMS: methanal; formalin (aqueous 30 to 60% w/v formaldehyde); methylene oxide

| SAMPLING | | MEASUREMENT | |
|---|--|--|---|
| SAMPLER: | CARTRIDGE (Cartridge containing silica gel coated with 2,4-dinitrophenylhydrazine) | TECHNIQUE: | HPLC, UV DETECTION |
| FLOW RATE: | 0.03 to 1.5 L/min | ANALYTE: | 2,4-dinitrophenylhydrazine of formaldehyde |
| VOL-MIN: | 1 L @ 0.25 mg/m ³ | EXTRACTION: | Elution with 10 mL of carbonyl-free acetonitrile |
| -MAX: | 15 L @ 2.5 mg/m ³ | INJECTION VOLUME: | 20 µL |
| SHIPMENT: | Place caps onto cartridge. Ship on ice. | MOBILE PHASE: | 45% acetonitrile/55% water (v/v), 1.3 mL/min |
| SAMPLE STABILITY: | 34 days @ 5 °C [1] | COLUMN: | 3.9 x 150-mm, stainless steel, packed with 5-µm C18 |
| BLANKS: | 2 to 10 field blanks per set; 6 to 10 media blanks per set | DETECTOR: | UV @ 360 nm |
| ACCURACY | | CALIBRATION: | Samplers fortified with standard solutions of formaldehyde in water |
| RANGE STUDIED: | 0.025 to 2.45 mg/m ³ (22-L samples) [2] | RANGE: | 0.23 to 37 µg per sample [1, 2] |
| BIAS: | +4.4% | ESTIMATED LOD: | 0.07 µg/sample [1] |
| OVERALL PRECISION (\hat{S}_{RT}): | 0.057 [1, 2] | PRECISION (\bar{S}_r): | 0.032 @ 1.0 to 20.0 µg/sample [1] |
| ACCURACY: | ±19.0% | | |

APPLICABILITY: The working range is 0.015 to 2.5 mg/m³ (0.012 to 2.0 ppm) for a 15-L sample. This method can be used for the determination of formaldehyde for both STEL and TWA exposures [1, 2].

INTERFERENCES: Ozone has been observed to consume the 2,4-dinitrophenylhydrazine (2,4-DNPH) reagent and to degrade the formaldehyde derivative [3]. Ketones and other aldehydes can react with 2,4-DNPH; the derivatives produced, however, are separated chromatographically from the formaldehyde derivative.

OTHER METHODS: NIOSH methods 2541 [4] and 3500 [5] and OSHA method 52 [6] are other methods for determination of formaldehyde in air. NIOSH method 5700 employs 2,4-DNPH and HPLC for determination of formaldehyde on textile or wood dust [7]. A journal method employs the same procedure for formaldehyde in automobile exhaust [8].

REAGENTS:

1. Formaldehyde stock solution,* aqueous, standardized, 1 mg/mL (see APPENDIX A). Alternatively, standardized formaldehyde solution, aqueous, 4 mg/mL (commercially available).
2. Acetonitrile,* distilled in glass, low carbonyl content.**
3. Water, deionized and distilled.
4. Sulfuric acid, 0.02 N (pH standardization procedure) or 0.1 N (colorimetric procedure).
5. Sodium hydroxide, 0.01 N.
6. Sodium sulfite (Na_2SO_3), 1.13 M (pH procedure) or 0.1 M (colorimetric procedure). Prepare fresh immediately before use.
7. Thymophthalein indicator solution, 0.04% (w/v) in 50:50 ethanol:water.

*See SPECIAL PRECAUTIONS.

**Carbonyl content of acetonitrile can be determined by passing 10 mL of the solvent through a cartridge of DNPH-coated silica gel and analyzing by HPLC. Formaldehyde content should be below the LOD.

EQUIPMENT:

1. Sampler: Plastic holder containing 0.35 g of 150-250 μm (60-100 mesh) silica gel coated with 1.0 mg of acidified 2,4-dinitrophenylhydrazine. Pressure drop across sampler should be less than 28 inches of water (7 kPa) at 1.5 L/min. Samplers are commercially available. (See APPENDIX B for additional information.)
2. Personal sampling pump, 0.03 to 1.5 L/min with flexible connecting tubing.
3. Vials, 4-mL, glass with PTFE-lined rubber septa caps.
4. Vials, 20-mL, glass.
NOTE: Do not use vials with "polycone" liners (sources of high formaldehyde blanks) [5, 9].
5. Liquid chromatograph with UV detector, recorder, integrator, and column (page 2016-1).
6. Syringes, 100- μL , 500- μL and 10-mL.
7. Volumetric flasks, 10-mL, 25-mL, and 1-L.
8. Burets, 50-mL.
9. pH meter.
10. Magnetic stirrer.
11. Beaker, 50-mL.
12. Flask, Erlenmeyer, 250-mL.
13. Ozone scrubber (optional).
14. Aluminum foil or black electrical tape (optional).

SPECIAL PRECAUTIONS: Formaldehyde is a suspect carcinogen and a proven human sensitizer; it should be handled in a fume hood [10-12]. Acetonitrile is toxic and is a fire hazard (flash point = 12.8 °C).

SAMPLING:

1. Calibrate each personal sampling pump with a representative sampler (and ozone scrubber, if used) in line.
2. Open sampler packet and remove end caps.
3. Attach sampler to the sampling pump with flexible tubing. Bi-directional samplers can be connected at either end.
NOTE: The sampler does not have a backup section for determination of breakthrough. If high concentrations of aldehydes and ketones are anticipated, connect two samplers in series. The back pressure of the sampling train will be higher and a lower flow rate may be required.
4. Sample 1 to 15 L of air at 0.03 to 1.5 L/min.
NOTE: To protect from intense light, such as bright sunlight, the sampler can be wrapped with aluminum foil or electrical tape.
5. Place end caps onto the sampler and seal sampler in an envelope. Protect samples from heat.
6. Ship samples on ice (0 °C).

SAMPLE PREPARATION:

NOTE: Check acetonitrile for formaldehyde content by elution and analysis of a blank cartridge; the formaldehyde level should be below the detection limit. Since background levels of formaldehyde on the samplers may change during storage, compare samples with sampler blanks from the same lot. Samples and blanks should be stored under the same conditions.

7. Elute the formaldehyde derivative from the cartridge samplers with 10-mL quantities of acetonitrile.
 - a. Collect effluent from each sampler in a 10-mL volumetric flask.
 - b. Add acetonitrile to the mark for each sampler.

NOTE: The silica gel bed of the sampler will retain approximately 0.5 mL of the original 10 mL.

CALIBRATION AND QUALITY CONTROL:

8. Calibrate daily with at least six media working standards over the range of interest.
 - a. Prepare a series of aqueous formaldehyde solutions for the fortification of samplers. Suggested concentrations include 1, 4, and 20 $\mu\text{g}/\text{mL}$. See APPENDIX A for standardization of formaldehyde in water.
 - b. Connect the outlet of a cartridge sampler to a personal sampling pump with flexible tubing. Turn on the pump and make sure there is a flow of air through the sampler.
 - c. Load a 100- μL syringe with a selected volume of aqueous formaldehyde solution in the range of 30 to 90 μL . Suggested quantities of formaldehyde for spiking include 0.04, 0.10, 0.20, 0.30, 0.40, 0.80, 1.0 and 2.0 $\mu\text{g}/\text{sample}$.
 - d. Place the tip of the syringe needle against the frit in the inlet of the sampler and eject the formaldehyde solution.
 - e. Prepare the media working standard (steps 7a and 7b).
 - f. Prepare additional working standards (steps 8b through 8e).
 - g. Transfer 3-mL aliquots of working standards to 4-mL vials, and analyze (steps 10, 12 and 13).
 - h. Prepare calibration graph, peak area or peak height vs. μg formaldehyde per sample.
9. Fortify and analyze three quality control spikes and three analyst spikes to ensure that calibration graph is in control.

MEASUREMENT:

10. Set liquid chromatograph according to manufacturer's recommendations and to conditions given on page 2016-1.
11. Transfer a 3-mL aliquot of the sample solution from step 7 to a 4-mL vial. Cap the vial.
12. Inject a 20- μL sample aliquot.
13. Measure peak area or peak height.

NOTE 1: If sample peak is larger than the largest standard peak, dilute an aliquot of the remaining sample solution, reanalyze, and apply appropriate dilution factor in the calculations.

NOTE 2: To ensure validity of the samples, identify those samples which contain more than 37 μg of formaldehyde. The capacity of the samplers before breakthrough may have been exceeded for these samples, and collection of smaller samples would be warranted.

NOTE 3: The size of the 2,4-DNPH peak should be about 2.7 times the size of the formaldehyde-DNPH peak or larger. Otherwise, breakthrough from the sampler may have occurred.

CALCULATIONS:

14. Determine mass, μg , of formaldehyde, W , found in the sample and the average media blank, B , from the calibration graph.

15. Calculate concentration, C , of formaldehyde in the air volume sampled, V (L).

$$C = \frac{W - B}{V}, \text{mg/m}^3$$

NOTE: $\mu\text{g/L} \cong \text{mg/m}^3$

EVALUATION OF METHOD:

Issue 1

This method was originally evaluated with Waters Sep-Pak XPoSure Aldehyde samplers using data produced at NIOSH and at Waters Corporation [2]. Test atmospheres of formaldehyde were generated at Waters Corp. [2]. Overall measurement precision, \hat{S}_{rT} , was 0.057 based on NIOSH guidelines [13] including a 5% pump error factor and estimated bias of +4.4%. Sample storage stability was evaluated over the range of 0.5 to 55 μg formaldehyde/sample. Losses for Waters samplers were 4 to 8% when stored up to 14 days at 4 °C. An additional study with Waters samplers found that losses were 5% or less after 4 days of storage at ambient temperature. All calibration standards used at Waters Corporation were liquid standard solutions of formaldehyde-DNPH derivative in acetonitrile [2, 14].

The capacity of DNPH-coated silica gel samplers was found to vary with relative humidity (RH) in addition to concentration of formaldehyde. At a formaldehyde concentration of 1.2 mg/m^3 and at 5% breakthrough, the Waters sampler had a capacity at <10% RH of 55 μg , and at >85% RH a capacity of 77 μg . At 2.4 mg/m^3 and <10% RH, the 5% breakthrough capacity of the Waters sampler was 59 μg of formaldehyde. At 2.6 mg/m^3 and >85% RH, the 5% breakthrough capacity was 106 μg . Thus, the smallest capacity at 5% breakthrough was 55 μg of formaldehyde; the upper limit of the range of the method is two thirds of 55 μg , or 37 μg . Capacity information for the Waters sampler is applicable to the Supelco sampler because (a) the Waters and Supelco samplers contain 0.9 and 1 mg of DNPH, respectively, and (b) each sampler contains 350 mg of silica gel.

Issue 2

In subsequent work on this method, additional formaldehyde samplers were evaluated, Supelco S10 LpDNPH cartridges and SKC, Inc. Aldehyde samplers (DNPH-coated silica gel tubes No.226-119) [1]. The sorbent beds of Supelco and Waters cartridges and front sections of SKC samplers were treated with acetonitrile. Formaldehyde was not detected on any blank sampler (LOD = 0.01 $\mu\text{g/mL}$). The SKC sampler for aldehydes may be used for formaldehyde with modifications of this method (See APPENDIX B). However, evaluation of the SKC sampler at NIOSH has been limited.

Supelco samplers were fortified with known quantities of free formaldehyde in water, and calibration was performed with media standards prepared from Supelco samplers fortified with known quantities of free formaldehyde in water; average recoveries ranged from 96.3% to 99.3% for five levels at 1.00 to 20 μg of formaldehyde per sampler (pooled $\bar{S}_r = 0.0316$; $n = 6$ at each level).

In a storage study, six Supelco samplers were fortified with 4- μg quantities of free formaldehyde in water. Samplers were stored 34 days at 5 °C in the dark; the average recovery based on media standards was 99% ($\bar{S}_r = 0.014$).

Eight media standards were prepared by fortification of Supelco samplers with solutions of free formaldehyde in water. The solutions were drawn through the DNPH-coated silica gel beds with an air pump. The resulting LOD and LOQ were 0.07 and 0.23 $\mu\text{g/sample}$, respectively, according to a least squares calibration graph.

Standard solutions of formaldehyde-DNPH at 0.10 and 1.0 µg/mL (formaldehyde equivalent concentrations) were stored in airtight vials at 5 °C in the dark and were analyzed periodically. The standard solutions were found to be stable (with no detectable loss) for at least 10 weeks and at least 12 weeks, respectively.

It is suggested that the reader see the Backup Data Report for a comparison of media standards with liquid standards for calibration [1]. Air sampling for a 24-hour period can be performed with a single Supelco sampler. Thus, background levels at <1 ppb can be determined.

REFERENCES:

- [1] Tucker SP [2002]. Formaldehyde backup data report for method 2016 issue 2. Cincinnati, OH: National Institute for Occupational Safety and Health. Unpublished.
- [2] Iraneta PC, Collamati RA, Costello DN, Crowley RJ, Fernandes RL, Hopkins MR, Knowles CE, Martin DM [1995]. A validation study of a new active sampler for the analysis of formaldehyde in workplace and indoor air. Milford, MA: Waters Corp. Unpublished.
- [3] Kleindienst TE, Corse EW, Blanchard FT [1998]. Evaluation of the performance of DNPH-coated silica gel and C18 cartridges in the measurement of formaldehyde in the presence and absence of ozone. *Environ Sci Technol* 32(1):124-130.
- [4] NIOSH [1994]. Formaldehyde by GC: Method 2541. In: Eller PM, Cassinelli ME, eds. NIOSH manual of analytical methods. 4th ed. Cincinnati, OH: U.S. Department of Health and Human Services, Centers for Disease Control and Prevention, National Institute for Occupational Safety and Health, DHHS (NIOSH) Publication No. 94-113.
- [5] NIOSH [1994]. Formaldehyde by VIS: Method 3500. In: Eller PM, Cassinelli ME, eds. NIOSH manual of analytical methods. 4th ed. Cincinnati, OH: U.S. Department of Health and Human Services, Centers for Disease Control and Prevention, National Institute for Occupational Safety and Health, DHHS (NIOSH) Publication No. 94-113.
- [6] OSHA [1985]. Formaldehyde: Method 52. In: OSHA analytical methods manual. Salt Lake City, UT: U.S. Department of Labor, Occupational Safety and Health Administration, OSHA Analytical Laboratory.
- [7] NIOSH [1994]. Formaldehyde on dust (textile or wood): Method 5700. In: Eller PM, Cassinelli ME, eds. NIOSH Manual of Analytical Methods. 4th ed. Cincinnati, OH: U.S. Department of Health and Human Services, Centers for Disease Control and Prevention, National Institute for Occupational Safety and Health, DHHS (NIOSH) Publication No. 94-113.
- [8] Lipari F, Swarin S [1982]. Determination of formaldehyde and other aldehydes in automobile exhaust with an improved 2,4-Dinitrophenylhydrazine method. *J Chromatogr* 247:297-306.
- [9] Dollberg DD, Smith DL, Tharr DG [1986]. Lab/Field coordination. *Appl Ind Hyg* 1:F44-F46.
- [10] ACGIH [2001]. 2001 Threshold limit values® and biological exposure indices. Cincinnati, OH: American Conference of Governmental Industrial Hygienists, Inc.
- [11] ACGIH [1991]. Formaldehyde. In: Documentation of Threshold Limit Values and Biological Exposure Indices, 6th ed. Cincinnati, OH: American Conference of Governmental Industrial Hygienists, Inc.
- [12] CFR. Code of Federal Regulations [1999]. Formaldehyde. In: Title 29, Part 1910.1048, 29 CFR Chapter XVII (7-1-99 Edition), 354-378. Washington, DC: U.S. Government Printing Office, Office of the Federal Register.

- [13] Kennedy ER, Fischbach TJ, Song R, Eller PE, Shulman SA [1995]. Guidelines for air sampling and analytical method development and evaluation. Cincinnati, OH: US Department of Health and Human Services, Centers for Disease Control and Prevention, National Institute for Occupational Safety and Health. DHHS (NIOSH) Publication No. 95-117.
- [14] Waters Corp. [1994]. Waters Sep-Pak XPoSure aldehyde sampler care and use manual. Milford, MA.
- [15] Walker JF [1964]. Formaldehyde. In: American chemical society monograph series. 3rd ed. Chapter 18. Reinhold Publishing Corporation, New York.

METHOD REVISED BY:

Samuel P. Tucker, Ph.D., NIOSH.

Method originally written by P Iraneta, Waters Corp., MJ Seymour and ER Kennedy, Ph.D., NIOSH.

APPENDIX A -PREPARATION AND STANDARDIZATION OF FORMALDEHYDE STOCK SOLUTION (ca. 1 mg/mL)

Preparation. Dilute 2.7 mL 37% aqueous formalin solution to 1 L with distilled, deionized water. This solution is stable for at least three months when stored at room temperature.

Standardization by pH Titration. Place 5.0 mL of freshly prepared 1.13 M sodium sulfite solution in a 50-mL beaker and stir magnetically. Adjust pH to between 8.5 and 10 with base or acid. Record the pH. Add 3.0 to 12.0 mL formaldehyde stock solution. The pH should now be greater than 11. Titrate the solution back to its original pH with 0.02 N sulfuric acid (1 mL acid = 0.600 mg formaldehyde; about 17 mL acid needed). If the endpoint pH is overrun, back-titrate to the endpoint with 0.01 N sodium hydroxide. Calculate the concentration, C_s (mg/mL), of the formaldehyde stock solution:

$$C_s = \frac{30.0(N_a V_a - N_b V_b)}{V_s}, \text{ mg/mL}$$

Where:

30.0 = 30.0 g/equivalent of formaldehyde

N_a = normality of sulfuric acid (0.02 N)

V_a = volume of sulfuric acid (mL) used for titration

N_b = normality of NaOH (0.01 N)

V_b = volume of NaOH (mL) used for back-titration

V_s = volume of formaldehyde stock solution (mL)

Standardization by Colorimetric Titration. Place 50 mL of freshly prepared 0.1 M sodium sulfite and 3 drops of 0.04% thymolphthalein indicator (w/v) in 50:50 ethanol:water into a 250-mL Erlenmeyer flask. Titrate the contents of the flask to a colorless endpoint with 0.1 N sulfuric acid (usually 1 or 2 drops is sufficient). The indicator is blue at pH values above the endpoint and is colorless at pH values below the endpoint. Transfer 3.0 to 12.0 mL of the formaldehyde solution to the same flask and titrate the mixture with 0.1 N sulfuric acid to a colorless endpoint. Calculate the concentration, C (mg/mL), of formaldehyde in solution.

$$C = \frac{30.0(N_a V_a)}{V_s}, \text{ mg/mL}$$

Where:

30.0 = g/equivalent of formaldehyde

N_a = normality of sulfuric acid (0.1 N)

V_a = volume of sulfuric acid used for titration (mL)

V_s = volume of formaldehyde stock solution (mL)

NOTE: Sulfuric acid (0.1 N) is substituted for 0.1 N hydrochloric acid, which is specified in OSHA Method 52, in order to prevent possible formation of bis(chloromethyl)ether, a potent carcinogen, by reaction of formaldehyde with hydrochloric acid [12].

This colorimetric titration was adapted from OSHA Method 52 [5], which was based on the procedure of Walker [15].

APPENDIX B - USE OF SKC SAMPLER FOR FORMALDEHYDE

DNPH-coated silica gel tubes may be used for sampling formaldehyde with modifications of this method. These modifications include the following:

- (a) The maximum recommended air volume should be less than 15 L at an air concentration of 2.5 mg/m³ (indicated on page 2016-1), because the upper limit of the method for the SKC sampler is probably less than 37 µg.
- (b) The procedure for recovery of analyte from the sorbent would be modified, i.e., placement of the sorbent sections in vials, addition of solvent, and possible use of an ultrasonic bath.
- (c) A volume of solvent much less than 10 mL can be used for recovery. However, the minimum volume should be tested for adequate recovery.
- (d) Consequences of using a much smaller volume of solvent for recovery include a lower LOD and LOQ, the need for a different range of calibration standards, and the need for a different range of fortification levels (step 8).
- (e) The maximum volume of solution for fortification of the front sorbent bed must be less than 90 µL and should be determined (step 8).

Disclaimer: Mention of any company or product does not constitute endorsement by NIOSH. In addition, citations to websites external to NIOSH do not constitute NIOSH endorsement of the sponsoring organizations or their programs or products. Furthermore, NIOSH is not responsible for the content of these websites. All web addresses referenced in this document were accessible as of the publication date.

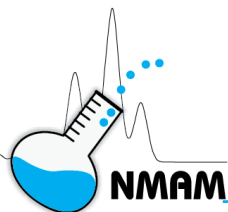

KETONES

2027

Formula: Table 1

MW: Table 1

CAS: Table 1

RTECS: Table 1

METHOD: 2027, Issue 1

EVALUATION: FULL

Issue 1: 19 July 2016

OSHA: Table 2

PROPERTIES: Table 1

NIOSH: Table 2

Other OELs: Refs [1,2]

SYNONYMS: See individual compounds in Table 1

| SAMPLING | | MEASUREMENT | |
|--|---|--|---|
| SAMPLER: | SOLID SORBENT TUBE (silica gel, 500 mg/1000 mg); min. of 2 field blanks per set | TECHNIQUE: | gas chromatography, FID |
| FLOW RATE: | 0.05 – 0.1 l/min | ANALYTE: | see Table 1 |
| VOL-MIN: | 2 L | DESORPTION: | ternary mixture of CH ₂ Cl ₂ /methanol/water (65:33:2) |
| -MAX: | 10 L | INJECTION VOLUME: | 1 µL |
| SHIPMENT: | routine | COLUMNS (IN PARALLEL): | 60 m low-polarity fused silica, ID 0.25 mm and film thickness 0.25 µm; and 60 m high-polarity polyethylene glycol, ID 0.25 mm and film thickness 0.25 µm. |
| SAMPLE STABILITY: | Stable at least 28 days @ 20 °C [3,4] | TEMPERATURE: | |
| ACCURACY | | INJECTION: | 250 °C |
| RANGE STUDIED: | Table 3 | DETECTOR: | 250 °C |
| BIAS: | Negligible | COLUMN: | 50 °C (11 min) to 150 °C (4 °C/min) |
| OVERALL PRECISION ($\hat{S}_{r,T}$): | Table 3 | CALIBRATION: | solution of analytes in desorption solvent |
| UNCERTAINTY: | Table 3 | RANGE: | Table 3 |
| | | ESTIMATED LOD: | Table 3 |
| | | PRECISION (\hat{S}_r): | Table 3 |

APPLICABILITY: 2-2400 mg/m³ for air sample vol. up to 10 L.

INTERFERENCES: Organic compounds with similar retention times as the analytes of interest may interfere.

OTHER METHODS: NIOSH 2553 and 2555 [5] are partially validated methods for the determination of ketones using CS₂ for desorption. OSHA methods based on sorbent tube sampling, solvent desorption and GC/FID analysis have been promulgated for several ketones [6].

REAGENTS:

1. Acetone, >99.8%, analytical grade.
2. 2-Butanone, >99.8%, analytical grade.
3. Cyclohexanone, >99.5%, analytical grade.
4. Cyclopentanone, >99.0% purity.
5. 2-Hexanone, >98 % purity.
6. 4-Methyl -2-pentanone, >99.0%, analytical grade.
7. 2,6-Dimethyl-4-heptanone, ≥99%, analytical grade.*
8. Methanol, >99.9 %, analytical grade.
9. Dichloromethane, analytical grade.
10. Water, ultrapure, ≥18.2 MΩ-cm resistivity.
11. 2-Methylheptane, chromatographic quality.
12. n-Undecane, chromatographic quality.
13. Air, prepurified and filtered.
14. Hydrogen, prepurified and filtered.
15. Helium, prepurified and filtered.
16. Nitrogen, prepurified and filtered.
17. Internal standard solution: Mix 500 µL of n-undecane and 500 µL 2-methylheptane.
18. Ternary mixture: Mix 650 mL dichloromethane, 330 mL methanol and 20 mL water in a 1000-mL- volumetric flask.

*NOTE: Each new bottle must be analyzed immediately after opening to accurately measure the concentration.

EQUIPMENT

1. Sampler: glass tube, length 125 mm, 7-mm OD, 5-mm ID, flame sealed ends, containing two sections of silica gel (front 500 mg, back 1000 mg) separated by a 2-mm ceramic plug. The ceramic plug is in front and a silylated glass wool plug follows the back section. Tubes are commercially available.
2. Personal sampling pump capable of producing flow rates between 0.05 to 0.1 L/min, with flexible connecting tubing.
3. Gas chromatograph, equipped with split injector (capillary flow split), two separation columns with separate FIDs, and data processing unit.
4. Fused silica capillary columns (for parallel separation): 60 m low-polarity fused silica, 0.25 mm ID and film thickness 0.25 µm. 60 m high-polarity polyethylene glycol, 0.25 mm ID and film thickness 0.25 µm.
5. Vessels, 15-mL, glass, with screw caps and PTFE septum.
6. Volumetric flasks, 5, 50 and 1000 mL.
7. Syringes, glass, 10 to 500 µL.
8. Pipettes, glass, 5 and 10 mL.
9. Bottles, polyethylene, 100 mL.
10. Syringes, polypropylene, 2 mL.
11. Syringe filter cartridges, with 0.45-µm pore size polytetrafluoroethylene (PTFE) membrane filters.
12. Micro-syringes, 50 µL, with 60 mm x 0.6 mm needles.
13. Auto-sampler vials, with PTFE septum, 1.5 mL capacity.

SPECIAL PRECAUTIONS: Analytes should be handled in a fume hood. Wear protective clothing and eyewear. Dichloromethane is a potential occupational carcinogen [12].

SAMPLING, SAMPLE TRANSPORT AND STORAGE

1. Calibrate each personal sampling pump with a representative sampler in the line.
2. Break the ends of the sampler immediately before sampling. Attach sampler to the personal sampling pump with flexible tubing.
3. Sample at an accurate known flow rate between 0.05 and 0.1 L/min for a total sample size of not more than 10 L.
4. Cap the samplers with plastic (not rubber) caps and pack securely for shipment.
5. Analyze samples within 28 days of receipt.

SAMPLE PREPARATION

6. Place the entire contents of the sorbent tube in a 15-mL screw-cap-vessel.
7. Add 5 mL ternary mixture and securely cap the vessel immediately.
8. Allow to stand at least 18 hours with occasional agitation.
9. Add 2.5 µL of internal standard solution.
10. Take sample solution with a 2-ml-polypropylene syringe and filter through a PTFE filter into an auto sampler vial.

CALIBRATION AND QUALITY CONTROL

11. Calibrate with at least six standards for each substance in the range given in Table 3.
 - a. Place the contents of a sorbent tube in a 15-mL screw-cap-vessel and add 5 mL ternary mixture solvent.
 - b. Add known amount of analyte.
 - c. Store at room temperature for 18 hours and then add 2.5 µL of internal standard solution.
Note: Internal standards are used to aid in identification of retention times of unknowns.
 - d. Analyze and prepare a calibration graph for the two columns separately (peak areas of analyte and internal standard (nonpolar column:2-methylheptane; polar column: n-undecane) vs concentration).
12. Prepare each day at least three quality control solutions in the same manner and range and analyze together with samples and blanks.
13. Determine desorption efficiency (DE) at least once for each batch of sorbent used for sampling in the calibration range.
 - a. Prepare three tubes at each of five levels plus three media blanks.
 - b. Inject a known amount of analyte solution directly onto the front sorbent section while drawing purified air through the tube.
 - c. Draw approximately 10 L air through the sorbent tube, then cap the ends of each tube and allow to stand overnight.
 - d. Desorb (steps 6 to 9) and analyze together with quality control samples and blanks (steps 14 to 15).
14. Analyze a minimum of three quality control spikes and three analyst spikes to insure that the calibration graph and the DE graph are in control.

MEASUREMENT

15. Set gas chromatograph parameters to manufacturer's recommendations and to conditions give on Page 1. Inject a 1-µL sample aliquot into the gas chromatograph.
NOTE: If the peak area exceeds the linear calibration range, dilute with desorption solvent, reanalyze and apply the appropriate dilution factor in calculations.
16. Measure analyte peak areas at applicable retention times (Table 4).

CALCULATIONS:

17. Calculate the mass concentration of each analyte, C (mg/m³), in the air volume sampled, V (L):

$$C = \frac{(C_1 \cdot V_1 \cdot F_d) - (C_0 \cdot V_0)}{V \cdot \eta}$$

where:

C_0 = mean concentration, in mg/L, of analyte in the field blank test solutions;

C_1 = concentration, in mg/L, of analyte in the sample test solution;

V = volume, in liters, of the air sample;

V_0 = volume, in mL, of the field blank test solutions;

V_1 = volume, in mL, of the sample test solutions;

F_d = dilution factor for each sample test solution;

η = desorption efficiency.

EVALUATION OF METHOD:

The method recovery, at levels from the LOQ to at least 2 times the REL, was determined for each analyte by carrying out sampling and analytical experiments at a dynamic test gas facility [3,4]. Experiments were conducted at four concentration levels of each analyte and for relative humidities of 20%, 50% and 80% at 20 °C. All analytes exhibited method recovery >95 % at the levels evaluated (see Table 3). At low relative humidity (<30%) the recoveries of cyclohexanone, cyclopentanone and 2-hexanone were reduced without water in the extraction solution. Use of a small content of water (2%) during extraction avoids losses based on low humidity during sampling. Each analyte, at levels below and above the REL, was evaluated for its storage stability [3,4]. The samples were prepared by sampling at a dynamic test gas device at a relative humidity of 50% (20 °C). The samples were then stored at room temperature for four weeks. All analytes demonstrated acceptable recoveries (>90%) after 28 days of storage [3]. The performance of the method was separately verified in independent laboratories [4,13].

REFERENCES:

- [1] American Conference of Governmental Industrial Hygienists (ACGIH), Threshold Limit Values for Chemical Substances and Physical Agents & Biological Exposure Indices. ACGIH: Cincinnati (2014); updated annually.
- [2] Institut für Arbeitsschutz der Deutschen Gesetzlichen Unfallversicherung (IFA), GESTIS – Database on International Limit Values for Hazardous Substances (German Social Accident Insurances). IFA: Sankt Augustin, Germany (2014); <https://www.dguv.de/ifa/index-2.jsp>.
- [3] Breuer, D.: Ketones, IFA Working Folder, Sheet No. 7708; Institute for Occupational Safety and Health of the German Social Accident Insurances. Erich Schmidt Verlag: Bielefeld, Germany (2005).
- [4] Breuer, D, Eisenhardt, A. Solvent mixtures, Method No. 4 (Ketones); in Air Monitoring Methods, The MAK Collection for Occupational Health and Safety. Wiley-VCH: Weinheim, Germany (2013).
- [5] NIOSH Manual of Analytical Methods, 4th ed., Method Nos. 2555 (Ketones I) and 2553 (Ketones II). CDC/NIOSH: Cincinnati (2003).
- [6] Occupational Safety and Health Administration (OSHA), Sampling and Analytical Methods (Method nos. 1, 16, 69, PV2031). OSHA Salt Lake Technical Center, Sandy, UT; www.osha.gov/dts/sltc/methods/index.html (accessed May 2015).

- [7] Institut für Arbeitsschutz der Deutschen Gesetzlichen Unfallversicherung (IFA), GESTIS – substance database (German Social Accident Insurances). IFA: Sankt Augustin, Germany (2014); <https://www.dguv.de/ifa/index-2.jsp>.
- [8] Sigma-Aldrich [2011]. 2012-2014 Handbook of Fine Chemicals. St. Louis, MO: Sigma-Aldrich Co.
- [9] NIOSH Pocket Guide to Chemical Hazards, DHHS (NIOSH), Cincinnati; www.cdc.gov/niosh/npg; (accessed June 2015).
- [10] EN 482: Workplace exposure – General requirements for the performance of procedures for the measurement of chemical agents. CEN: Brussels (2012).
- [11] EN 1076: Workplace exposure – Procedures for measuring gases and vapours using pumped samplers – Requirements and test methods. CEN: Brussels (2009).
- [12] NIOSH [1986]. Current intelligence bulletin 46: Methylene Chloride, U.S. Department of Health and Human Services, Centers for Disease Control and Prevention, National Institute for Occupational Safety and Health, DHHS (NIOSH) Publication No. 86-114.
- [13] Bureau Veritas North America [2016]. Ketones User Check Sequence 11762-CA (unpublished report). BVNA: Novi, MI, 3 Feb. 2016.

METHOD WRITTEN BY:

Dietmar Breuer, Dr. rer. nat. and Anna Eisenhardt, Institute for Occupational Safety and Health of the German Social Accident Insurances (IFA), Sankt Augustin, Germany.

Disclaimer: Mention of any company or product does not constitute endorsement by NIOSH. In addition, citations to websites external to NIOSH do not constitute NIOSH endorsement of the sponsoring organizations or their programs or products. Furthermore, NIOSH is not responsible for the content of these websites. All web addresses referenced in this document were accessible as of the publication date.

Table 1. Synonyms, Formulae, Molecular weights, Properties, CAS#, RTECS

| Compound/ synonyms CAS# RTECS | Empirical formula | Molecular weight | Boiling point ^a (°C) | Melting point ^a (°C) | Vapor pressure @ 20°C (kPa) ^a | Vapor pressure @ 20°C (mm Hg) ^a | Density @ 20 °C ^a (g/mL) |
|---|----------------------------------|---------------------|---------------------------------------|---------------------------------------|---|---|---|
| Acetone / 2-Propanone 67-64-1 AL3150000 | C ₃ H ₆ O | 58.08 | 56.2 | -95 | 24.6 | 184 | 0.79 |
| 2-Butanone Methylethyl ketone 78-93-3 EL6475000 | C ₄ H ₈ O | 72.11 | 79.6 | -86 | 10.5 | 78.8 | 0.81 |
| Cyclohexanone / Cyclohexyl ketone 108-94-1 GW1050000 | C ₆ H ₁₀ O | 98.14 | 155.6 | -26 | 0.455 | 3.41 | 0.95 |
| Cyclopentanone / Ketocyclopentane 120-92-3 GY4725000 | C ₅ H ₈ O | 84.12 | 130.6 | -58.2 | 1.14 | 8.55 | 0.95 |
| 2-Hexanone / Butyl methyl ketone 591-78-6 MP1400000 | C ₆ H ₁₂ O | 100.16 | 127.2 | -56 | 1.28 | 9.60 | 0.81 |
| 4-Methyl-2- pentanone / MIBK/Methyl isobutyl ketone 108-10-1 SA9275000 | C ₆ H ₁₂ O | 100.16 | 116.8 | -80.3 | 1.88 | 14.1 | 0.80 |
| 2,6-Dimethyl-4- heptanone/ Diisobutyl ketone 108-83-8 MJ5775000 | C ₉ H ₁₈ O | 142.24 | 168 | -46 | 0.23 ^b | 1.7 ^b | 0.81 |

^a Physical and chemical property data from GESTIS substance database, except where noted otherwise [7]

^b Vapor pressure for 2,6-dimethyl-4-heptanone [8]

Table 2. Occupational exposure limits, ppm [9]

| Substance | OSHA PELs | | NIOSH RELs | | mg/m ³ per ppm |
|--------------------------|-----------|------|------------|------|---------------------------|
| | TWA | STEL | TWA | STEL | |
| Acetone | 1000 | | 250 | | 2.41 |
| 2-Butanone | 200 | | 200 | 300 | 2.95 |
| Cyclohexanone | 50 | | 25 | | 4.08 |
| Cyclopentanone | | | | | 3.50 |
| 2-Hexanone | 100 | | 1 | | 4.16 |
| 4-Methyl-2-pentanone | 100 | | 50 | 75 | 4.16 |
| 2,6-Dimethyl-4-heptanone | 50 | | 25 | | 5.91 |

Table 3. Measurement range, precision, uncertainty and recovery (N=6)

| Substance | LOD (mg/sample) | LOQ (mg/sample) | Measurement Range (mg/sample) | Precision (S _r) | U ^a (%) | Mean Recovery (DE) |
|------------------------------|--------------------|--------------------|-------------------------------------|--------------------------------|-----------------------|--------------------------|
| Acetone | 0.006 | 0.02 | 0.02 – 26 | 0.0083- 0.024 | 11 – 12 | 0.97 |
| 2-Butanone | 0.006 | 0.02 | 0.02 – 14 | 0.0078- 0.024 | 11 – 12 | 0.98 |
| Cyclohexanone | 0.006 | 0.02 | 0.02 – 12 | 0.010- 0.022 | 12 – 13 | 0.97 |
| Cyclopentanone | 0.006 | 0.02 | 0.02 – 2 | 0.008- 0.023 | 11 – 12 | 0.95 |
| 2-Hexanone | 0.006 | 0.02 | 0.02 – 0.47 | 0.018- 0.022 | 11 – 12 | 0.98 |
| 4-Methyl-2- pentanone | 0.006 | 0.02 | 0.02 – 2 | 0.011- 0.023 | 11 – 12 | 0.99 |
| 2,6-Dimethyl-4- heptanone | 0.005 | 0.02 | 0.02 – 5 | 0.006- 0.023 | 11 – 12 | 1.01 |

^a Expanded uncertainty calculated in accordance with EN 482 [10] and EN 1076 [11]

Table 4. Approximate retention times on polar and nonpolar separation columns

| Substance | Approximate retention time non-polar column (min) | Approximate retention time polar column (min) |
|------------------------------|---|---|
| Acetone | 6.5 | 7.1 |
| 2-Butanone | 9.2 | ^{a)} |
| Cyclohexanone | 25.5 | 25.9 |
| Cyclopentanone | 20.3 | 21.2 |
| 2-Hexanone | 20.0 | 17.3 |
| 4-Methyl-2-pentanone | 17.2 | 13.8 |
| 2,6-Dimethyl-4- heptanone | 28.4 | 22.0 |

^{a)} The retention time of butanone is equal to that of the solvent on the polar column.



ANISIDINE

2514

CH₃OC₆H

MW: 123.16

CAS: (*o*-) 90-04-0
(*p*-) 104-94-9

RTECS: (*o*-) BZ5410000
(*p*-) BZ5450000

METHOD: 2514, Issue 3

EVALUATION: FULL

Issue 1: 15 May 1985

Issue 3: 26 February 2016

OSHA: 0.5 mg/m³ (skin)

NIOSH: 0.5 mg/m³ (skin);

o-isomer suspect carcinogen

PROPERTIES: *o*-isomer: liquid; d 1.092 g/mL @ 15 °C;
BP 225 °C; MP 5 °C; VP 0.1 mm Hg @ 27 °C.
p-isomer: solid; MP 57 °C; BP 246 °C

SYNONYMS: *o*-isomer: 2-aminoanisole; 2-methoxybenzenamine; *o*-methoxyaniline;
p-isomer: 4-aminoanisole; 4-methoxybenzenamine; *p*-methoxyaniline

| SAMPLING | | MEASUREMENT | |
|--|--|--|---|
| SAMPLER: | SOLID SORBENT TUBE (XAD-2, 150 mg/75 mg) | TECHNIQUE: | HPLC, UV DETECTION |
| FLOW RATE: | 0.5 – 1.0 L/min | ANALYTE: | <i>o</i> -anisidine and <i>p</i> -anisidine |
| VOL-MIN: | 24 L | DESORPTION: | 5 mL methanol; stand 15 min |
| MAX: | 320 L | INJECTION VOLUME: | 10 µL |
| SHIPMENT: | routine | MOBILE PHASE: | 5% acetonitrile/65% water @ 1.2 mL/min; ambient temperature |
| SAMPLE STABILITY: | at least 1 week @ 25 °C [1] | COLUMN: | 50 cm x 2-mm ID stainless steel packed with C18 |
| BLANKS: | 2 to 10 field blanks per set | DETECTOR: | UV absorption @ 254 nm |
| ACCURACY | | CALIBRATION: | analytes dissolved in methanol |
| RANGE STUDIED: | 0.13 to 0.58 mg/m ³ [1] (225-L samples) | RANGE: | 12 to 360 µg per sample (each isomer) [2] |
| BIAS: | 0.12% | ESTIMATED LOD: | 0.35 µg per sample [2] |
| OVERALL PRECISION ($\bar{S}_{r,T}$): | 0.068 [1] | PRECISION (\bar{S}_r): | 0.029 @ 30 to 240 µg per sample [1] HPLC/UV |
| ACCURACY: | ± 13.3% | | |

APPLICABILITY: The working range is 0.06 to 0.8 mg/m³ (0.012 to 0.16 ppm) for a 200-L air sample

INTERFERENCES: None identified

OTHER METHODS: This revises Method S163 [2]. This method replaces P&CAM 168 [3] because XAD-2 has a much greater capacity than silica gel for *o*-anisidine at high humidity [1].

REAGENTS:

1. *p*-Anisidine, reagent grade.*
2. *o*-Anisidine, reagent grade.*
3. Methanol, HPLC grade.*
4. Acetonitrile, HPLC grade.*
5. Water, distilled, deionized.
6. Methylene chloride.
7. Calibration stock solution, 15.0 mg/mL *p*-anisidine and 15.3 mg/mL *o*-anisidine. Dissolve 750 mg *p*-anisidine and 700 µL *o*-anisidine in methanol to make 50 mL solution.
8. HPLC mobile phase: 35% acetonitrile/65% water. Filter (5-µm PTFE) and degas prior to use.

*See SPECIAL PRECAUTIONS.

EQUIPMENT:

1. Sampler: glass tube, 7-cm long, 8-mm OD, 6-mm ID, with plastic caps, containing two sections of 20/50 mesh XAD-2 (150 mg front and 75 mg back) separated and held in place by plugs of silylated glass wool. Pressure drop across the tube must be <3.4 kPa (2.5 cm Hg) at 1 L/min airflow.
2. Personal sampling pump, 0.5 to 1 L/min, with flexible connecting tubing.
3. HPLC with UV absorption detector at 254 nm, integrator and column (page 2514-1).
4. Vials, 20-mL, scintillation.
5. Pipet, 5-mL.
6. Syringes, 10-µL, readable to 0.1 µL.
7. Volumetric flasks, 5- and 50-mL.

SPECIAL PRECAUTIONS: Anisidine can irritate the skin. Methanol and anisidine can be absorbed through the skin. Avoid inhalation of vapors of these compounds and of acetonitrile [4].

SAMPLING:

1. Calibrate each personal sampling pump with a representative sampler in line.
2. Uncap the sampler immediately before sampling. Attach sampler to personal sampling pump with flexible tubing.
3. Sample at an accurately known flow rate between 0.5 and 1.0 L/min for a total sample size of 24 to 320 L. Do not sample at less than 0.5 L/min.
4. Cap the samplers. Pack securely for shipment.

SAMPLE PREPARATION:

5. Place the front and back sections of the sampler in separate vials. Discard the glass wool plugs.
6. Add 5.0 mL methanol to each vial. Cap each vial and swirl vigorously.
7. Allow to stand for 15 min. Analyze within one day.

CALIBRATION AND QUALITY CONTROL:

8. Calibrate daily with at least six working standards over the range 0.4 to 360 µg anisidine per sample for each isomer.
 - a. Add a known volume of calibration stock solution, or a dilution thereof in methanol, to a 5-mL volumetric flask and dilute to the mark with methanol.
 - b. Analyze together with samples and blanks (steps 11 and 12).
 - c. Prepare calibration graph (peak area vs. µg analyte) for each isomer.
9. Determine desorption efficiency (DE) at least once for each lot of XAD-2 used for sampling in the concentration range of interest. Prepare four tubes at each of five levels.
 - a. Remove and discard the back sorbent section of a media blank sampler.
 - b. Inject a known amount (e.g., 1 to 20 µL) of calibration stock solution, or a dilution thereof in methanol, directly onto the front section with a microliter syringe.
 - c. Cap the tube. Allow to stand overnight.

- d. Desorb (steps 5 through 7) and analyze with working standards (steps 11 and 12).
 - e. Prepare graphs of DE vs. μg isomer recovered.
10. Analyze three quality control blind spikes and three analyst spikes with each subsequent set from the same lot to ensure that the calibration graph and DE graph are in control.

MEASUREMENT:

11. Set HPLC to conditions given on page 2514-1. Inject sample aliquot.
NOTE: Sensitivity is ca. 0.083 absorbance unit/mg of either isomer in a 10-mL injection volume with a 1-cm flow cell. Approximate retention times are 7.5 min for *p*-anisidine and 12 min for *o*-anisidine.
12. Measure peak area.

CALCULATIONS:

13. Determine the quantities (sum of quantities of the *o*- and the *p*-isomers corrected for DE), mg of analytes found in the sample front (W_f) and back (W_b) sorbent sections, and in the average media blank front (B_f) and back (B_b) sorbent sections.
NOTE: If $W_b > W_f/10$, report breakthrough and possible sample loss.
14. Calculate the sum of the concentrations, C , of the isomers in the air volume sampled, V (L):

$$C = \frac{W_f + W_b - B_f - B_b}{V}, \text{ mg/m}^3$$

EVALUATION OF METHOD:

Method S163 was issued on February 16, 1979 [2], and was validated over the range 0.13 to 0.58 mg/m^3 for the *o*-isomer and 0.12 to 0.58 mg/m^3 for the *p*-isomer using 225-L air samples [1, 5]. The generation system was constructed so that samples were generated for both isomers at the same time. Concentrations were verified by an independent method using bubblers containing methanol and HPLC analysis [1]. The overall precision, $\hat{S}_{r,T}$, for the combined sampling and measurement of both isomers was 0.068 with an average recovery of 100.7% for the *o*-isomer and 99.7% for the *p*-isomer [1], which represent non-significant biases for the isomers. A separate breakthrough test was conducted for each isomer with XAD-2. Samples were taken at ca. 1.0 L/min. *o*-Anisidine was generated at 1.03 mg/m^3 with a relative humidity of 81% at 21 °C. Breakthrough (3%) from 150 mg XAD-2 occurred after 236 min, but did not increase above this amount up to 479 min. *p*-Anisidine was generated at 1.04 mg/m^3 with a relative humidity of 82% at 20 °C. Breakthrough did not occur during the 361-min test. Samples containing both isomers were stored for one week at room temperature and found to be stable. Desorption efficiencies averaged 0.95 and 0.91 for *o*- and *p*-anisidine, respectively, in the range 30 to 240 μg per sample.

REFERENCES:

- [1] NIOSH [1979]. Backup data report S163. Unpublished.
- [2] NIOSH [1979]. Anisidine, *o* & *p* isomers: Method S163. In: Taylor DG, ed. NIOSH Manual of analytical methods. 2nd ed (vol. 5). Cincinnati, OH: U.S. Department of Health, Education, and Welfare, Center for Disease Control, National Institute for Occupational Safety and Health, DHEW (NIOSH) Publication No. 79-141.
- [3] NIOSH [1977]. Aromatic amines in air: Method P&CAM168. In: Taylor DG, ed. NIOSH Manual of analytical methods. 2nd ed (vol. 1). Cincinnati, OH: U.S. Department of Health, Education, and Welfare, Center for Disease Control, National Institute for Occupational Safety and Health, DHEW (NIOSH) Publication No. 77-157-A.

- [4] NIOSH [1981]. NIOSH/OSHA Occupational health guidelines for occupational hazards. Cincinnati, OH: U.S. Department of Health and Human Services, Centers for Disease Control, National Institute for Occupational Safety and Health, DHHS (NIOSH) Publication No. 81-12.
- [5] NIOSH [1980]. NIOSH research report - development and validation of methods for sampling and analysis of workplace toxic substances. Cincinnati, OH: U.S. Department of Health and Human Services, Centers for Disease Control, National Institute for Occupational Safety and Health, DHHS (NIOSH) Publication No. 80-133.

METHOD REVISED BY:

Edward Slick, NIOSH; S163 originally validated under NIOSH Contract 210-76-0123.

Disclaimer: Mention of any company or product does not constitute endorsement by NIOSH. In addition, citations to websites external to NIOSH do not constitute NIOSH endorsement of the sponsoring organizations or their programs or products. Furthermore, NIOSH is not responsible for the content of these websites. All web addresses referenced in this document were accessible as of the publication date.



METHYL BROMIDE

2520

CH₃Br MW: 94.94 CAS: 74-83-9 RTECS: PA4900000

METHOD: 2520, Issue 3

EVALUATION: FULL

Issue 1: 15 May 1985

Issue 3: 20 January 2016

OSHA: C 20 ppm (skin)
 NIOSH: Lowest feasible; carcinogen
 (1 ppm = 3.95 mg/m³ @ NTP)

PROPERTIES: Gas; d 1.73 g/mL @ 0 °C; BP 4 °C; VP 189.34 kPa (1420 mmHg) @ 20 °C

SYNONYMS: Monobromomethane; bromomethane

| SAMPLING | MEASUREMENT |
|--|--|
| <p>SAMPLER: SOLID SORBENT TUBES (two petroleum charcoal tubes, 400 mg and 200 mg; drying tube, 9 g sodium sulfate, necessary at humidity >50%)</p> <p>FLOW RATE: 0.01 L/min to 0.1 L/min</p> <p>VOL-MIN: 1 L @ 5 ppm -MAX: 5 L with drying tube, 1 L without drying tube [1]</p> <p>SHIPMENT: Ship on dry ice at -10 °C [1]</p> <p>SAMPLE STABILITY: Six d at -10 °C [1]</p> <p>BLANKS: 2 to 10 field blanks per set</p> | <p>TECHNIQUE: GAS CHROMATOGRAPHY, ATOMIC EMISSION DETECTION (GC-AED) monitoring bromine, carbon, and hydrogen channels</p> <p>ANALYTE: Methyl bromide</p> <p>DESORPTION: 400 mg tube: 3 mL methylene chloride; 200 mg tube: 2 mL methylene chloride</p> <p>INJECTION: 1 µL</p> <p>TEMPERATURE-INJECTOR: 250 °C -TRANSFER LINE/CAVITY BLOCK: 250 °C -COLUMN: 30 °C, 3.5 min; 12 °C/min to 130 °C; hold 1 min</p> |
| ACCURACY | <p>CARRIER GAS: Helium</p> <p>COLUMN: US Pharmacopeia (USP) G2 capillary, 30 m × 0.32 mm ID, 1.0 µm film thickness; 1 m × 0.53 mm deactivated fused silica pre-column</p> <p>CALIBRATION: Brominated compounds in methylene chloride</p> <p>RANGE: 33.0 µg to 2687 µg bromine per sample</p> <p>ESTIMATED LOD: 16.6 µg per sample [1]</p> <p>PRECISION (\bar{S}): 0.066 [1]</p> |
| <p>RANGE STUDIED: 0.84 ppm to 32.0 ppm (5 L samples)</p> <p>BIAS: -5.2%</p> <p>OVERALL PRECISION (\hat{S}_{pr}): 0.089</p> <p>ACCURACY: ±19.4%</p> | |

APPLICABILITY: The working range is 0.84 ppm to 32.0 ppm (3.3 mg/m³ to 126 mg/m³) for a 5 L sample. Ceiling measurement samples may require dilution when analyzed.

INTERFERENCES: Water vapor interferes with collection at relative humidities (RH) >50%. To eliminate the interference, precede the sampling train with a drying tube, and limit the sample volume to 5 L. If drying tubes are not available, limit the sample volume to 1 L under humid conditions.

OTHER METHODS: This is NIOSH method 2520 [2] revised to account for humidity effects, as well as instability of standards and samples. Other researchers [3] have prepared methyl bromide standards gravimetrically and used GC-ECD for analysis. The gravimetric calibration procedure did not give consistent results when compared with the procedure used in this revision of NIOSH method 2520. GC-ECD with a US Pharmacopeia (USP) S3 capillary column may be an alternative technique to GC-AED if other bromine standards are used to confirm the concentration of methyl bromide standards.

REAGENTS:

1. Eluant: methylene chloride,* chromatographic grade.
2. Methyl bromide,* 99.5%.
3. Calibration stock solution: To 4 mL of methylene chloride, add 12 μ L dibromomethane.
NOTE: Other brominated compounds may be used if liquid at room temperature.
4. Desorption stock solution: Bubble methyl bromide gas slowly into chilled eluant. Determine the methyl bromide concentration by comparison with calibration standards.
5. Helium,* prepurified, 99.995%.
6. Oxygen,* ultra purified, as reagent gas for plasma, 207 kPa (30 psi).
7. Air, filtered.
8. Dry ice, flaked, for chilling solvent.

*See SPECIAL PRECAUTIONS.

EQUIPMENT:

1. Sampler: petroleum charcoal sampling tubes; two glass tubes, each tube, 10 cm long, 8 mm OD, 6 mm ID, containing 20/40 mesh activated (600 °C) petroleum charcoal, first tube 400 mg, second tube 200 mg, held in place with silylated glass wool plugs; drying tube, glass, 9 g sodium sulfate. Tubes are connected in series with short pieces of plastic tubing. Pressure drop across sampler <3.4 kPa (25 mmHg) at 1.0 L/min airflow. Tubes are commercially available.
NOTE: If RH \geq 50%, precede sampling train with drying tube.
2. Personal sampling pump, 0.01 to 0.1 L/min, with flexible connecting tubing.
3. Gas chromatograph, atomic emission detector (helium plasma), integrator or computer, and column (page 2520-1).
4. Vials, 4 mL and 10 mL, glass, with PTFE-lined caps.
5. Syringe, gas-tight, 10 mL.
6. Microliter syringes, 10 μ L, 50 μ L, 100 μ L, 250 μ L, 500 μ L for preparing standard solutions.
7. Pipettes, 2 mL, graduated in 0.1 mL increments.

SPECIAL PRECAUTIONS: Methylene chloride is a suspect carcinogen. Methyl bromide is a suspect carcinogen and is toxic by ingestion, inhalation, and skin absorption [4]. Users must be familiar with the proper use of flammable and nonflammable gases, cylinders, and regulators.

SAMPLING:

1. Calibrate each personal sampling pump with a representative sampler in line.
2. Break the ends of the sampling tubes immediately before sampling. Attach sampler to personal sampling pump with flexible tubing.
NOTE: Place drying tube in front of the sorbent train.
3. Sample at an accurately known flow rate between 0.01 L/min and 0.1 L/min for a total sample size of 1.0 L to 5.0 L.
NOTE: Limit sample volume to 1.0 L if RH \geq 50% and no drying tube is used.
4. Separate the front and back tubes immediately after sampling. Cap the tubes. Pack securely in dry ice for shipment. Store at -10 °C until analysis.

SAMPLE PREPARATION:

5. Place the sorbent sections from each sampling tube in separate vials. Discard the glass wool plugs.
6. Add 3.0 mL chilled eluant (methylene chloride) to each 400 mg section, and 2.0 mL chilled eluant to each 200 mg section. Immediately cap each vial.
7. Allow to stand at least 30 min at room temperature with occasional agitation. Rechill before transferring to autosampler vials or diluting.
NOTE: Because of the volatility of the analyte, it is suggested that any dilutions be prepared at the

time of transfer to autosampler vials. Dilutions can be stored in the freezer until determined that they are needed.

CALIBRATION AND QUALITY CONTROL:

8. Calibrate daily with at least six working standards over the range 0.14 µg to 272 µg methyl bromide per sample from calibration stock solution.

NOTE: 0.085 µmol/µL bromine is equivalent to a methyl bromide concentration of 8.07 µg/µL.

- a. Add known aliquots (2.0 µL, 20 µL, 45 µL, and 120 µL) of calibration stock solution to methylene chloride in 10 mL vials with PTFE-lined caps. Take 1 mL of lowest standard and dilute to 10 mL with methylene chloride. Transfer standards to autosampler vials and immediately cap each vial.
 - b. Analyze together with samples and blanks (steps 11 and 12).
 - c. Prepare calibration graph (peak area vs. concentration).
9. Determine desorption efficiency (DE) at least once for each lot of charcoal used for sampling in the calibration range (step 8). Prepare three tubes at each of five levels plus three media blanks.
 - a. Inject a known amount (1 µL to 10 µL) of methyl bromide desorption stock solution (concentration determined against other brominated compounds), or a serial dilution thereof, directly onto media blank samplers with a microliter syringe.
 - b. Cap the tubes. Allow to stand overnight at 0 °C.
 - c. Desorb (steps 5, 6, and 7) and analyze together with working standards (steps 11 and 12).
 - d. Prepare a graph of DE vs. µg bromine recovered.
 10. Analyze three quality control blind spikes and three analyst spikes to ensure that the calibration graph and DE graph are in control.

MEASUREMENT:

11. Set gas chromatograph-atomic emission detector to manufacturer's recommendations and to conditions given on page 2520-1. Inject sample aliquot manually using solvent flush technique or with autosampler.

NOTE 1: Methyl bromide elutes before the methylene chloride solvent peak. Vent the solvent peak to avoid extinguishing the helium plasma. Vent time ranges from 3.2 min to 5.9 min; this may need to be adjusted for each system.

NOTE 2: If peak area is above the linear range of the working standards, dilute with eluant, reanalyze, and apply the appropriate dilution factor in calculations.

12. Measure peak area.

CALCULATIONS:

13. Determine the mass, µg (corrected for DE) of methyl bromide found in the 400 mg sample tube (W_f) and 200 mg sample tube (W_b), and in the average media blanks for the 400 mg (B_f) and 200 mg (B_b) sorbent tubes.

NOTE: If $W_f > W_b / 10$, report breakthrough and possible sample loss.

14. Calculate concentration, C , of methyl bromide in the air volume sampled, V (L):

$$C = \frac{W_f + W_b - B_f - B_b}{V}, \text{ µg/L or mg/m}^3.$$

EVALUATION OF METHOD:

NIOSH method 2520 for methyl bromide, issued in May 1985 [2], was based on NIOSH method S372 [5]. Issue 2 (dated 5/15/96) of NIOSH method 2520 was further revised to account for the effect of humidity and to address the instability of standards and samples [1]. The addition of a drying tube to the sampling train helped reduce the effects of >50% RH. The analytical technique was changed to GC

with atomic emission detection (GC-AED). The atomic emission detector monitors individual elements, in this case bromine, independent of the source compound. Calibration can be done with brominated compounds that are liquid at room temperature, thereby eliminating the need for methyl bromide standards. Methylene chloride replaced carbon disulfide as desorption solvent.

The revised NIOSH method 2520 (issued 5/15/96) for methyl bromide was evaluated at 7.8 mg/m³, 20.0 mg/m³, and 125.0 mg/m³ (2 ppm, 5 ppm, and 32 ppm, respectively) [1]. Test atmospheres were generated by delivering methyl bromide gas from two diffusion tubes kept at -12 °C into an airstream flowing at 12 L/min. Humidity was added downstream when needed, and airflow passed through two mixing chambers before reaching a sampling manifold. The concentration was monitored with a total hydrocarbon analyzer and confirmed by calibrating against other brominated standards by GC-AED. Three compounds used as calibration standards (dibromomethane, 1-bromopropane, and 1-bromobutane) were chosen as closest in chemical structure to methyl bromide, although a compound-independent response was assumed [6]. A three-compound calibration was used during the development of the GC-AED analytical procedure. Since there was good agreement between the three compounds, the method was written with only one brominated standard, dibromomethane.

When challenged with methyl bromide at a calculated concentration of 27 ppm, the capacity of the sampler (a 400 mg petroleum charcoal tube plus a 200 mg petroleum charcoal tube) at 40% RH and 20 °C was 1386.5 µg regardless of flow rate (10.5 mL/min, 40 mL/min, or 100 mL/min). However, at 100% RH and 39 °C, the average capacity fell to 298.6 µg. With a 9 g sodium sulfate drying tube in line, the capacity was increased to 651.8 µg; concentration averaged 130 mg/m³ (33 ppm). Even with a drying tube in line, severe breakthrough occurred at the 10 L sample volume (50% was found on the back tube). Without the use of a drying tube, a 1 L sample volume is recommended, based on a 170.6 µg capacity (1.6 L) found at the 40 mL/min rate multiplied by a 0.67 caution factor.

Recovery fell below 70% for sample loadings less than 58 µg when carbon disulfide was used for desorption (Figure 1). This would not allow accurate sampling at 7.8 mg/m³ (2 ppm), the exposure level most frequently encountered. Therefore, alternate desorption solvents were tested. Desorption with methylene chloride improved recovery at the 15 µg level to 76.7%. However, sample stability still fell below 70% after storage for six days at -10 °C regardless of sample level. This stability limitation remains a concern and rapid sample analysis is required.

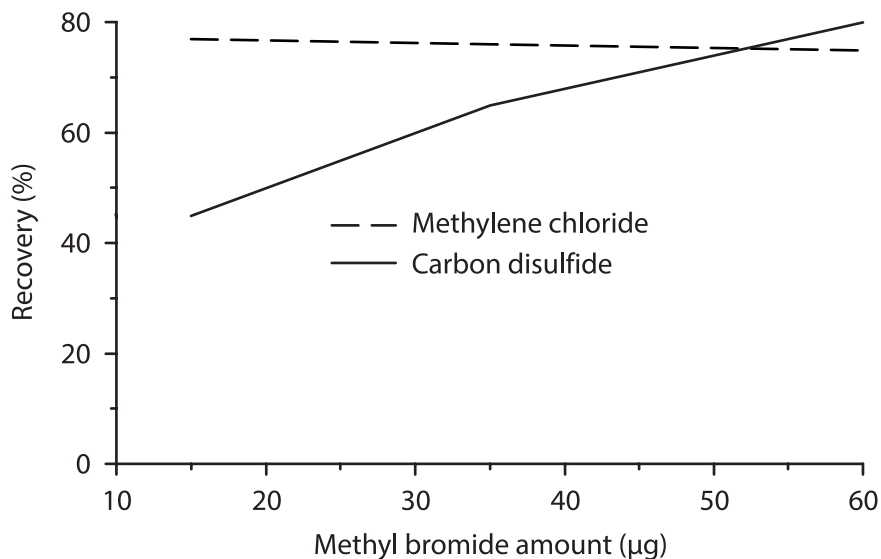

Figure 1. Comparison of desorption solvents.

REFERENCES:

- [1] NIOSH [1995]. Research into problems with NIOSH method 2520 for methyl bromide. By Gagnon YT, Ringenburt VL, Fajen JM. Cincinnati, OH: U.S. Department of Health and Human Services, Centers

- for Disease Control and Prevention, National Institute for Occupational Safety and Health, available as accession No. PB95-179842 from NTIS [www.ntis.gov]. Unpublished.
- [2] NIOSH [1984]. Methyl bromide: Method 2520 (supplement issued 5/15/85). In: Eller PM, ed. NIOSH manual of analytical methods. 3rd ed. Cincinnati, OH: U.S. Department of Health and Human Services, Centers for Disease Control, National Institute for Occupational Safety and Health, DHHS (NIOSH) Publication No. 84-100, available as accession No. PB86-116266 from NTIS [www.ntis.gov].
- [3] Woodrow JE, McChesney MM, Sieber JN [1988]. Determination of methyl bromide in air samples by headspace gas chromatography. *Anal Chem* 60:509–512.
- [4] NIOSH [1984]. Current intelligence bulletin 43—monohalomethanes: methyl chloride, methyl bromide, methyl iodide. Cincinnati, OH: U.S. Department of Health and Human Services, Centers for Disease Control, National Institute for Occupational Safety and Health, DHHS (NIOSH) Publication No. 84-117, available as accession No. PB85-178549 from NTIS [www.ntis.gov].
- [5] NIOSH [1977]. Methyl bromide: Method S372. In: Taylor DG, ed. NIOSH manual of analytical methods. 2nd ed. Vol. 3. Cincinnati, OH: U.S. Department of Health, Education, and Welfare, Center for Disease Control, National Institute for Occupational Safety and Health, DHEW (NIOSH) Publication No. 77-157-C, available as accession No. PB276838 from NTIS [www.ntis.gov].
- [6] Weile Y, Yieru H, Qingyu O [1992]. Quantitative characteristics of gas chromatography with microwave-induced plasma detection. In: Uden PC, ed. Element-specific chromatographic detection by atomic emission spectroscopy. Washington DC: American Chemical Society, ACS Symposium Series No. 479, pp. 44–61.

METHOD REVISED BY:

Yvonne T. Gagnon, MRB/DPSE/NIOSH

DISCLAIMER: Mention of any company or product does not constitute endorsement by NIOSH. In addition, citations to websites external to NIOSH do not constitute NIOSH endorsement of the sponsoring organizations or their programs or products. Furthermore, NIOSH is not responsible for the content of these websites. All web addresses referenced in this document were accessible as of the publication date.

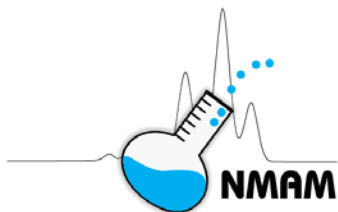

GLUTARALDEHYDE

2531

O=CH(CH₂)₃CH=O MW: 100.12 CAS: 111-30-8 RTECS: MA2450000

METHOD: 2531, Issue 3

EVALUATION: FULL

Issue 1: 15 May 1989

Issue 3: 20 January 2016

OSHA: No PEL
 NIOSH: C 0.2 ppm
 (1 ppm = 4.09 mg/m³ @ NTP)

PROPERTIES: Oil; d 0.72 g/mL @ 20 °C; BP 188 °C; MP
 -14 °C; VP 2.2 kPa (17 mmHg) @ 20 °C

SYNONYMS: Glutaric dialdehyde; 1,5-pentanedial

| SAMPLING | MEASUREMENT |
|---|--|
| <p>SAMPLER: SOLID SORBENT TUBE (10% 2-(hydroxymethyl)piperidine on XAD-2, 120 mg/60 mg)</p> <p>FLOW RATE: 0.01 L/min to 0.08 L/min, or 0.2 L/min for 20 min</p> <p>VOL-MIN: 4 L @ 0.2 ppm -MAX: 39 L</p> <p>SHIPMENT: Routine</p> <p>SAMPLE STABILITY: At least 5 weeks @ 25 °C [1]</p> <p>FIELD BLANKS: 2 to 10 field blanks per set</p> <p>MEDIA BLANKS: 10 per set</p> | <p>TECHNIQUE: GAS CHROMATOGRAPHY, FID</p> <p>ANALYTE: Oxazolidine derivative of glutaraldehyde</p> <p>DESORPTION: 2 mL toluene; 60 min ultrasonic</p> <p>INJECTION: 1 µL splitless; split vent time 30 s</p> <p>TEMPERATURE-INJECTOR: 250 °C -DETECTOR: 280 °C -COLUMN: 1 min @ 70 °C; 20 °C/min; hold 2 min @ 290 °C</p> <p>CARRIER GAS: Helium, 0.5 mL/min; makeup 2.9 mL/min</p> <p>COLUMN: Capillary, 10 m × 0.25 mm, 5% phenyl, 95% methyl polysiloxane (US Pharmacopeia (USP) phase G27)</p> <p>CALIBRATION: Standard glutaraldehyde solutions spiked on sorbent</p> |
| ACCURACY | |
| <p>RANGE STUDIED: 0.8 mg/m³ to 9 mg/m³ [1] (22 L samples)</p> <p>BIAS: 0.3%</p> <p>OVERALL PRECISION (\hat{S}_r): 0.087 [1]</p> <p>ACCURACY: ±17.4%</p> | <p>RANGE: 3 µg to 180 µg per sample [1]</p> <p>ESTIMATED LOD: 1 µg per sample [2]</p> <p>PRECISION (\bar{S}): 0.093 [2] @ 5 µg to 50 µg per sample [1]</p> |

APPLICABILITY: The working range is 0.03 ppm to 2 ppm (0.14 mg/m³ to 8 mg/m³) for a 22 L air sample; the method is sensitive enough for ceiling determinations. The method is suitable for the simultaneous determination of furfural and glutaraldehyde.

INTERFERENCES: None have been observed.

OTHER METHODS: This is a new method. A wide-bore 10 m capillary column is an alternate chromatographic column.

REAGENTS:

1. Toluene,* chromatographic quality.
2. 2-(Hydroxymethyl)piperidine. Recrystallize several times from isooctane until there is one major peak (>95% of area) by GC analysis. Store in desiccator.
3. XAD-2 resin.
4. Glutaraldehyde,* 250 g/L solution in water.
5. Glutaraldehyde stock solution, 10 µg/µL (see Appendix A).
6. Glutaraldehyde oxazolidine (see Appendix B) stock solution, 2 mg/mL. Add 20 mg to toluene and dilute to 10 mL.
7. Sulfuric acid,* 0.01 mol/L.
8. Sodium hydroxide,* 0.01 mol/L.
9. Sodium sulfite, 1.13 mol/L. Dissolve 14.2 g reagent grade sodium sulfite in deionized, distilled water and dilute to 100 mL. Prepare fresh immediately before use.
10. Water, deionized, then distilled.
11. Hydrogen,* prepurified.
12. Air, filtered.
13. Helium,* prepurified.
14. Magnesium sulfate.

*See SPECIAL PRECAUTIONS.

EQUIPMENT:

1. Sampler: resin-filled sampling tube; glass tube, 10 cm long, 6-mm OD, 4-mm ID, flame-sealed ends and plastic caps, containing two sections of 40/60 mesh 2-(hydroxymethyl)piperidine-coated XAD-2 (see Appendix C). Sorbent sections are retained and separated by small plugs of silanized glass wool. Pressure drop across the tube at 0.10 L/min airflow must be less than 0.76 kPa (5.7 mmHg). Tubes are commercially available.
2. Personal sampling pump, 0.01 L/min to 0.08 L/min, with flexible connecting tubing.
3. Gas chromatograph, flame ionization detector, integrator, and column (page 2531-1).
4. Ultrasonic bath.
5. Vials, glass, 4 mL, with septum and plastic screw caps.
6. Flasks, volumetric, 10 mL, 25 mL, and 50 mL.
7. Pipets, TD, 1 mL, 2 mL, and 10 mL with pipet bulb.
8. Pipets, disposable, 2 mL.
9. Syringes, 10 µL (readable to 0.1 µL), 25 µL, and 50 µL.
10. File.
11. Beakers, 50 mL.
12. pH meter.
13. Magnetic stirrer.
14. Burets, 50 mL.
15. Flasks, round-bottomed, 100 mL.
16. Soxhlet extraction apparatus.
17. Vacuum oven.
18. Distillation apparatus.

SPECIAL PRECAUTIONS: Glutaraldehyde can irritate the mucous membranes and act on the central nervous system [3]. Toluene is flammable. Sulfuric acid is highly corrosive and sodium hydroxide is caustic. All work with these compounds should be performed in a well-ventilated hood. Use proper protective clothing including gloves, safety glasses, and laboratory coat. Users must be familiar with the proper use of flammable and nonflammable gases, cylinders, and regulators.

SAMPLING:

1. Calibrate each personal sampling pump with a representative sampler in line.
2. Break ends of the sampler immediately before sampling. Attach sampler to personal sampling pump with flexible tubing.
3. Sample at an accurately know flow rate between 0.01 and 0.08 L/min for a total sample size of 4 L to 39 L. For ceiling determination, sample at 0.2 L/min for 20 min.

NOTE: The aldehyde reacts with the 2-(hydroxymethyl)piperidine to form an oxazolidine derivative in the sorbent bed during sampling (see equation below). Sampling rate is limited by the speed of this reaction. Sampling rates above 0.1 L/min for extended periods may cause breakthrough owing to incomplete reaction, possibly invalidating the sample.

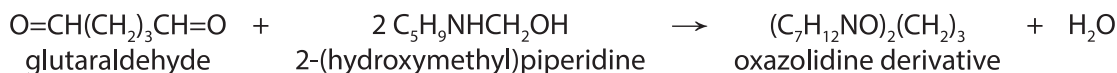
**SAMPLE PREPARATION:**

4. Score each sampler with a file in back of the back sorbent section.
5. Break sampler at score line. Remove and place back glass wool plug and back sorbent section in a vial.
6. Transfer front section with remaining glass wool plugs to a second vial.
7. Add 2.0 mL toluene to each vial. Screw cap tightly onto each vial.
8. Agitate vials in an ultrasonic bath for 60 min.

NOTE: Desorption efficiency is affected by the amount of time that the vials are allowed to spend in the ultrasonic bath. A minimum of 60 min residence time in the ultrasonic bath is required to ensure adequate desorption.

CALIBRATION AND QUALITY CONTROL:

9. Prepare glutaraldehyde oxazolidine standard solutions.
 - a. Add known amounts of glutaraldehyde oxazolidine stock solution (equivalent to the range of the samples) to toluene in 10 mL volumetric flasks and dilute to the mark.
 - b. Analyze (steps 12 and 13) with samples and blanks for qualitative identification of derivative peaks.
10. Calibrate daily with at least five working standards covering the range of the samples.
 - a. Weigh 120 mg portions of unused sorbent from media blanks into vials.
 - b. Add aliquots of glutaraldehyde stock solution or dilutions thereof. Cap vials and allow them to stand overnight at room temperature.
 - c. Desorb (steps 7 and 8) and analyze (steps 12 and 13) with samples and blanks.
 - d. Prepare calibration graph (combined peak area vs. μg glutaraldehyde).

NOTE: Because the working standards are prepared on media blanks, no additional blank correction or desorption efficiency correction is necessary. Check desorption efficiency occasionally in the range of interest (see Appendix D).
11. Analyze three quality control blind spikes to ensure that the calibration graph is in control.

MEASUREMENT:

12. Set gas chromatograph to manufacturer's recommendations and to conditions given on page 2531-1. Inject 1 μL sample aliquot.

NOTE: If the amount of oxazolidine in the aliquot exceeds the capacity of the column, dilute the sample with toluene and apply the appropriate dilution factor in calculations.
13. Measure total peak area of the two analyte peaks.

NOTE: On the recommended column, the oxazolidine derivative gives two peaks, since the diastereoisomers are resolved; t_r for the glutaraldehyde derivative = 9.4 min and 9.7 min; t_r for 2-(hydroxymethyl)piperidine = 2.6 min for these conditions.

CALCULATIONS:

14. Determine the mass, μg , of glutaraldehyde found in the sample front (W_f) and back (W_b) sorbent sections.

NOTE: If $W_f > W_b / 10$, report breakthrough and possible sample loss.
15. Calculate concentration, C , of glutaraldehyde in the air volume sampled, V (L):

$$C = \frac{W_f + W_b}{V}, \mu\text{g/L or mg/m}^3.$$

EVALUATION OF METHOD:

Atmospheres were generated by injection of an aqueous solution of glutaraldehyde by syringe pump into a heated block injector and flash vaporization into a stream of air flowing at a fixed rate [1]. Relative humidity during generation was controlled at 80% ±5%. The generator and sampling manifold systems have been described previously [4]. Concentration of glutaraldehyde vapor was independently verified by the 2,4-dinitrophenylhydrazine procedure of Lipari and Swarin [5]. No bias with dynamically-generated atmospheres was observed with the method over the range 0.8 mg/m³ to 8 mg/m³ using 22 L air samples. Desorption efficiencies on statically-spiked samples averaged 87% in the ranges 5 µg to 50 µg per sample. Recovery averaged 1.10 with $S_r = 0.043$ for twelve tubes spiked with 67 µg glutaraldehyde [6].

REFERENCES:

- [1] Kennedy ER, Gagnon YT, Okenfuss JR, Teass AW [1988]. The determination in air of selected low-molecular weight aldehydes as their oxazolidines by capillary gas chromatography. *Appl Ind Hyg* 3(10):274–279.
- [2] NIOSH [1987, 1989]. Analytical reports: sequence No. 5827 (November 13, 1987); sequence No. 6565-J (February 27, 1989). Cincinnati, OH: U.S. Department of Health and Human Services, Centers for Disease Control, National Institute for Occupational Safety and Health, Division of Physical Sciences and Engineering. Unpublished.
- [3] Windholz M, Budavari S, Blumetti RF, Otterbein ES, eds. [1983]. *The Merck index: an encyclopedia of chemicals, drugs, and biologicals*. 10th ed. Rahway, NJ: Merck & Co., Inc.
- [4] Kennedy ER, Hill RH [1982]. Determination of formaldehyde in air as an oxazolidine derivative by capillary gas chromatography. *Anal Chem* 54(11):1739–1741.
- [5] Lipari F, Swarin SJ [1982]. Determination of formaldehyde and other aldehydes in automobile exhaust with an improved 2,4-dinitrophenylhydrazine method. *J Chromatogr* 247:297–306.
- [6] NIOSH [1989]. User check, NIOSH sequence No. 6565-M. Cincinnati, OH: U.S. Department of Health and Human Services, Centers for Disease Control, National Institute for Occupational Safety and Health, Division of Physical Sciences and Engineering. Unpublished.

METHOD WRITTEN BY:

Julie R. Okenfuss and Eugene R. Kennedy, Ph.D., NIOSH/DPSE.

DISCLAIMER: Mention of any company or product does not constitute endorsement by NIOSH. In addition, citations to websites external to NIOSH do not constitute NIOSH endorsement of the sponsoring organizations or their programs or products. Furthermore, NIOSH is not responsible for the content of these websites. All web addresses referenced in this document were accessible as of the publication date.

APPENDIX**A. Preparation and Standardization of Glutaraldehyde Stock Solution (about 10 µg/µL)**

Dilute 1 mL of 250 g/L aqueous glutaraldehyde to 25 mL with distilled, deionized water to make the glutaraldehyde stock solution. Put 10.0 mL of 1.13 mol/L sodium sulfite solution in a beaker and stir magnetically. Adjust pH to between 8.5 and 10 with base or acid. Record the pH. Add 1.0 mL glutaraldehyde stock solution. The pH should be about 12. Titrate the solution back to its original pH with 0.01 mol/L sulfuric acid. If the endpoint pH is overrun, back-titrate to the endpoint with 0.01 mol/L sodium hydroxide. Calculate the concentration, C_s , of the glutaraldehyde stock solution:

$$C_s = \frac{(C_a V_a - C_b V_b) \times 50.06}{V_s}, \mu\text{g}/\mu\text{L},$$

where: 50.06 = MW of glutaraldehyde divided by 2,

C_a = concentration (mol/L) of sulfuric acid,

V_a = volume of sulfuric acid (mL) used for titration,

C_b = concentration (mol/L) of sodium hydroxide,

V_b = volume of sulfuric acid (mL) used for titration, and

V_s = volume of glutaraldehyde stock solution (1.0 mL).

B. Synthesis of Glutaraldehyde Oxazolidine

Place a solution of purified 2-(hydroxymethyl)piperidine (0.57 g, 5 mmol) in 10 mL of toluene in a 50 mL round-bottomed flask. Several 2 mL portions of toluene can be used to rinse residual 2-(hydroxymethyl)piperidine from the container used for weighing. Add magnesium sulfate (2.5 g) to the round-bottomed flask to dry the glutaraldehyde solution as it is added and to remove the water which forms during the reaction. Add a solution of 1 mL of 250 g/L aqueous glutaraldehyde (0.25 g, 2.5 mmol) in 10 mL of toluene to the 2-(hydroxymethyl)piperidine solution dropwise with stirring over 1 h. Stir the solution overnight, then filter to remove the magnesium sulfate. Remove the toluene from the solution at reduced pressure by rotary evaporation. The product is a yellow viscous oil, about 90% to 95% pure. NOTE: Exact amounts of reagent are required for this synthesis since excess glutaraldehyde can cause appreciable formation of the mono-oxazolidine derivative of glutaraldehyde.

C. Sorbent Preparation (optional if commercially prepared tubes are used)

Extract XAD-2 sorbent 4 h in a Soxhlet extractor with a mixture of equal volumes of acetone and methylene chloride. Replace with fresh solvent and repeat. Vacuum dry overnight. Add 1 g purified 2-(hydroxymethyl)piperidine in 50 mL toluene for each 9 g extracted XAD-2 sorbent. Allow this mixture to stand 1 h with occasional swirling. Remove the solvent by rotary evaporation at 37 °C and dry at 0.13 kPa (1 mmHg) at ambient temperature for approximately 1 h. To determine the amount of background for each batch, extract several 120 mg portions of the coated sorbent with toluene and analyze (steps 7, 8, 9, 10, 11, 12, and 13). No blank peak is expected for glutaraldehyde.

D. Desorption Efficiency

The determination of desorption efficiency (DE) is not necessary when using the calibration procedure in step 10. If desired, the following procedure can be used to determine DE:

1. Prepare and analyze a set of glutaraldehyde oxazolidine standard solutions (step 9.a) and a set of working standards (step 10), including media blanks.
2. Treating the working standards as unknowns, read the mass (μg) of oxazolidine found in each working standard (W), and in the average media blank (B).
3. Using the mass of glutaraldehyde, μg , spiked onto the working standard (W_o) and the stoichiometric conversion factor between glutaraldehyde and glutaraldehyde oxazolidine (2.94), calculate the desorption efficiency $(W - B) / (W_o \times 2.94)$.
4. Prepare a graph of DE vs. μg glutaraldehyde recovered per sample $(W - B) / 2.94$.

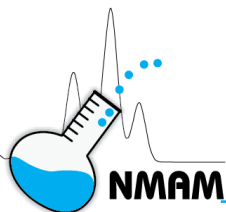

VALERALDEHYDE

2536

CH₃(CH₂)₃CH=O

MW: 86.13

CAS: 110-62-3

RTECS: YV3600000

METHOD: 2536, Issue 4

EVALUATION: FULL

Issue 1: 15 May 1989

Issue 4: 3 March 2016

OSHA: none
NIOSH: 50 ppm

PROPERTIES: liquid; d 0.810 g/mL @ 20 °C; BP 103 °C; VP 6.7 kPa (50 mm Hg) @ 25 °C; vapor density (air = 1) 3.0; flash point = 12.2 °C

SYNONYMS: pentanal; amyl aldehyde.

| SAMPLING | | MEASUREMENT | |
|--|--|--|---|
| SAMPLER: | SOLID SORBENT TUBE (10% 2-(hydroxymethyl)piperidine on XAD-2, (120 mg/60 mg) | TECHNIQUE: | GAS CHROMATOGRAPHY, FID |
| FLOW RATE: | 0.01 - 0.04 L/min | ANALYTE: | valeraldehyde oxazolidine (9-butyl-1-aza-8-oxabicyclo[4.3.0]nonane) |
| VOL-MIN: | 0.5 L @ 50 ppm | DESORPTION: | 2 mL toluene, 60 min ultrasonic |
| -MAX: | 10 L | INJECTION VOLUME: | 1 µL splitless |
| SHIPMENT: | routine | TEMPERATURE INJECTION: | 250 °C |
| SAMPLE STABILITY: | at least 4 weeks @ 25 °C [1] | - DETECTOR: | 280 °C |
| FIELD BLANKS: | 2 to 10 field blanks per set | -COLUMN: | 0.5 min @ 70°C; 50 °C/min to 120°C, hold 4 min; 20°C/min to 170°C, hold 7 min |
| MEDIA BLANKS: | 18 per set | CARRIER GAS: | He, 27 cm/sec linear velocity makeup flow 29 mL/min |
| ACCURACY | | COLUMN: | capillary, 15 m x 0.32-mm, 5% phenyl, 95% methyl polysiloxane, 1-µm film (US Pharmacopeia (USP) G-27) |
| RANGE STUDIED: | 9 to 374 mg/m ³ [1] (12-L samples) | CALIBRATION: | standard solutions of valeraldehyde on sorbent |
| BIAS: | 0.12% | RANGE: | 4 to 3900 µg/sample [1] |
| OVERALL PRECISION ($\hat{S}_{r,T}$): | 0.073 [1] | ESTIMATED LOD: | 2 µg/sample [1] |
| ACCURACY: | ± 14.4% | PRECISION (\hat{S}_r): | 0.066 @ 2 to 508 µg per sample [1] |

APPLICABILITY: The working range is 0.11 to 110 ppm (0.4 to 390 mg/m³) for a 10-L air sample. The method is also suitable for determination of furfural and glutaraldehyde in a mixture [2].

INTERFERENCES: None have been observed; an alternate capillary column, 15 m x 0.32-mm cyanopropylphenyl dimethylpolysiloxane 1-µm film (USP G43) can be used.

OTHER METHODS: The method of Lipari and Swarin [3] uses 2,4-dinitrophenylhydrazine for the collection of valeraldehyde.

REAGENTS:

1. Toluene, chromatographic quality.
2. 2-(Hydroxymethyl) piperidine. Recrystallize several times from isooctane until there is one major peak (>95% of area) by GC analysis. Store in desiccator.
3. XAD-2. Extract 4 h in Soxhlet with 50/50 (v/v) acetone/methylene chloride. Replace with fresh solvent and repeat. Vacuum dry overnight. (Optional if commercial tubes are used.)
4. Valeraldehyde, * 99% purity.
5. Valeraldehyde stock solution, 40 µg/µL (see APPENDIX). Add 400 mg valeraldehyde to toluene and dilute to 10 mL.
6. Valeraldehyde oxazolidine stock solution, 10 mg/mL (see APPENDIX A). Add 0.10 g 9-butyl-1-aza-8-oxabicyclo-[4.3.0] nonane to toluene and dilute to 10 mL.
7. Hydrogen, prepurified.
8. Air, filtered, compressed.
9. Helium, purified.
10. Magnesium sulfate, anhydrous.

*See SPECIAL PRECAUTIONS.

EQUIPMENT:

1. Sampler: resin-filled sampling tube; glass tube, 10 cm long, 6-mm OD, 4-mm ID, flame-sealed ends with plastic caps, containing two sections of 2-(hydroxymethyl) piperidine-coated XAD-2 (front = 120 mg, back = 60 mg) (see APPENDIX B). Sorbent sections are retained and separated by small plugs of silanized glass wool. Pressure drop across the tube at 0.1 L/min must be less than 760 Pa (5.7 mm Hg). Tubes are commercially available.
2. Personal sampling pump, 0.01 to 0.04 L/min, with flexible connecting tubing.
3. Gas chromatograph, flame ionization detector, integrator and column (page 2536-1).
4. Ultrasonic bath.
5. Vials, glass, 4-mL, with septum and plastic screw caps.
6. Flasks, volumetric, 10-, 25-, and 50-mL.
7. Pipets, volumetric, 1-, 2-, and 10-mL with pipet bulb.
8. Pipets, disposable, 2-mL.
9. Syringes, 10-µL (readable to 0.1 µL), 25-, and 50-µL.
10. File or tube scorer.
11. Beakers, 50-mL.
12. Magnetic stirrer.
13. Flasks, round-bottomed, 100-mL.
14. Soxhlet extraction apparatus.
15. Vacuum oven.
16. Distillation apparatus.

SPECIAL PRECAUTIONS: Valeraldehyde can irritate the mucous membranes [4]. It is flammable, a dangerous fire risk. Toluene is extremely flammable. All work should be performed in a well-ventilated

fume hood.

SAMPLING:

1. Calibrate each personal sampling pump with a representative sampler in line.
2. Break ends of the sampler immediately before sampling. Attach sampler to personal sampling pump with flexible tubing.
3. Sample at an accurately known flow rate between 0.01 and 0.04 L/min for a total sample size of 0.5 to 10 L.

NOTE: Sampling rate is limited by the speed of the following reaction. Rates above 0.04 L/min may cause appreciable breakthrough owing to incomplete reaction, possibly invalidating the sample.

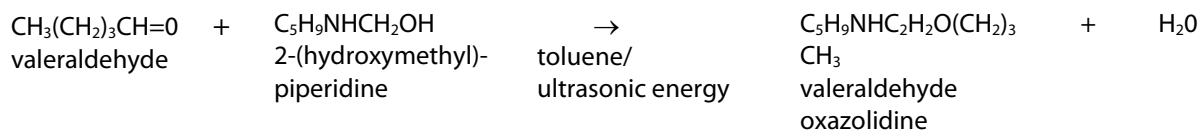
**SAMPLE PREPARATION:**

4. Score each sampler with a file or tube scorer in back of the back sorbent section.
5. Break sampler at score line. Remove and place back glass wool plug and back sorbent section in a vial.
6. Transfer front section with remaining glass wool plugs to a second vial.
7. Add 2.0 mL toluene to each vial. Screw cap tightly onto each vial.
8. Agitate in an ultrasonic bath for 60 min.

CALIBRATION AND QUALITY CONTROL:

9. Identification of analytical peaks.
 - a. Add known amounts of valeraldehyde oxazolidine stock solution to toluene in 10-mL volumetric flasks and dilute to the mark.
 - b. Analyze (steps 12 and 13) with samples and blanks for qualitative identification of derivative peaks.
10. Calibrate daily with a least six working standards prepared in triplicate covering the range 2 to 3900 μg valeraldehyde per sample.
 - a. Weigh 120-mg portions of unused sorbent from media blanks into vials.
 - b. Add aliquots (1 to 10 μL) of valeraldehyde stock solution, or dilutions thereof, to the sorbent. Cap vials and allow to stand overnight at room temperature.
 - c. Desorb (steps 7 and 8) and analyze (steps 12 and 13) with samples and blanks.
 - d. Prepare calibration graph (combined peak area vs. μg valeraldehyde).

NOTE: Because the standard samples are prepared on media blanks, no additional blank correction or desorption efficiency correction is necessary. Check desorption efficiency in the range of interest and at least once over the entire range of the method with each lot of sorbent used. (see APPENDIX C).
11. Analyze three quality control blind spikes and three analyst spikes to ensure that the calibration graph is in control.

MEASUREMENT:

12. Set gas chromatograph to manufacturer's recommendations and to conditions given on page 2536-1. Inject 1- μL sample aliquot.

NOTE: If the amount of valeraldehyde oxazolidine in the aliquot exceeds the capacity of the column, dilute with toluene, reanalyze and apply the appropriate dilution factor in calculations. The upper limit for the column on (page 2536-1) is equivalent to ca. 260 μg valeraldehyde per sample.
13. Measure total peak area of the two analyte peaks.

NOTE: Valeraldehyde oxazolidine gives two peaks, since the diastereoisomers are resolved with retention times 5.4 and 6.3 min. Retention time for 2-(hydroxymethyl) piperidine is 2.2 min for these conditions.

CALCULATIONS:

14. Determine the mass, μg , of valeraldehyde found in the sample front (W_f) and back (W_b) sorbent sections.
NOTE: If $W_b > W_f/10$, report breakthrough and possible sample loss.
15. Calculate concentration, C , of valeraldehyde in the air volume sampled, V (L):

$$C = \frac{W_f + W_b}{V}, \text{mg}/\text{m}^3$$

EVALUATION OF METHOD:

Atmospheres were generated by injection of valeraldehyde with a syringe pump into a heated block injector and flash vaporizer into a stream of air at $80\% \pm 5\%$ RH flowing at a fixed rate. The generator and sampling manifold system have been described previously [5]. Concentration of valeraldehyde vapor was independently verified by the 2,4-dinitrophenylhydrazine procedure of Lipari and Swarin [3] or by monitoring with an AID Model 590 organic vapor monitor. Breakthrough studies of valeraldehyde at 100 ppm, conducted at 75 and 50 mL/min flow rates, gave 5% breakthrough at 170 min and 280 min, respectively.

The method was evaluated over the range of 9 to 374 mg/m^3 using 12-L samples. Desorption efficiencies from statically-spiked samples average 102.5% (89.2-126.6%) for the range 2 to 508 $\mu\text{g}/\text{sample}$. No bias with dynamically-generated samples was observed with the method when samples were collected at 40 mL/min and below. When samples were collected at ca. 60 mL/min, a negative bias of approximately 20-30% was observed. Samples were found to be stable for at least 4 weeks when stored at room temperature.

REFERENCES:

- [1] Kennedy ER, Gagnon YT, Okenfuss JR, Teass AW [1988]. The determination in air of selected low-molecular weight aldehydes as their oxazolidines by capillary gas chromatography. *Appl Ind Hyg* 3(10): 274-279.
- [2] NIOSH [1984]. Glutaraldehyde: Method 2531. In: Eller PM, Cassinelli ME, eds. NIOSH manual of analytical methods. 3rd. ed. Cincinnati, OH: U.S. Department of Health and Human Services, Centers for Disease Control, National Institute for Occupational Safety and Health, DHHS (NIOSH) Publication No. 84-100.
- [3] Lipari F, Swarin SJ [1982]. Determination of formaldehyde and other aldehydes in automobile exhaust with an improved 2,4-dinitrophenylhydrazine method. *J Chromatog* 247:297-306.
- [4] Budavari S, ed. [1989]. *The Merck Index*. 11th ed. Rahway, NJ: Merck & Co., Inc.
- [5] Kennedy ER Hill RH, Jr. [1982]. Determination of formaldehyde in air as an oxazolidine derivative by capillary gas chromatography. *Anal Chem* 54:1739-1741.

METHOD REVISED BY:

Yvonne T. Gagnon and Eugene R. Kennedy, Ph.D., NIOSH

APPENDIX A: Synthesis of 9-Butyl-1-Aza-8-Oxabicyclo[4.3.0]nonane:

Place a solution of purified 2-(hydroxymethyl)piperidine (1.15 g; 10 mmol) in 20 mL of toluene in a 100- mL round-bottomed flask. Use several 2-mL portions of toluene to rinse residual 2- (hydroxymethyl)piperidine from the container used for weighing. Add anhydrous magnesium sulfate (2.0 g) to the flask to dry the valeraldehyde solution as it is added and to remove the water which forms during the reaction. Add a solution of 0.947 g valeraldehyde (11 mmole) in 20 mL of toluene to the 2- (hydroxymethyl)piperidine solution dropwise with stirring over 1 h. (NOTE: Excess aldehyde was added to ensure complete conversion of 2-(hydroxymethyl)piperidine to oxazolidine.) Stir the solution overnight, then filter to remove the magnesium sulfate. Remove the toluene from the solution at reduced pressure (1 mm Hg) by rotary evaporation. The product is a pale yellow viscous oil, ca. 90 to 95% pure by gas chromatography. Store the oxazolidine at 0 °C to prevent decomposition.

Mass spectral data for 9-butyl-1-aza-8-oxabicyclo[4.3.0]nonane: m/e with relative intensities in parenthesis, 182 (7.0%), 152 (4.6%), 126 (100%), 110 (11.3%), 98 (37%). IR data (Vapor phase @ 280 °C) for this compound in cm⁻¹ with relative intensity in parenthesis are: 2945 (s), 2874 (m), 2781 (m), 1455 (w), 1383 (w), 1339 (w), 1265 (w), 1203 (w), 1133 (m), 1075 (w), 1028 (m).

APPENDIX B: Sorbent Preparation (optional if commercially-prepared tubes are used):

Add 1 g purified 2-(hydroxymethyl)piperidine in 50 mL toluene for each 9 g extracted XAD-2 sorbent. Allow this mixture to stand 1 h with occasional swirling. Remove the solvent by rotary evaporation at 37°C. Dry at 130 Pa (1 mm Hg) at ambient temperature for approximately 1 h. To determine the amount of background for each batch, desorb several 120-mg portions of the coated sorbent with toluene and analyze (steps 7 through 13). No blank peak is expected for valeraldehyde.

APPENDIX C: Desorption Efficiency:

The determination of desorption efficiency (DE) is not necessary when using the calibration procedure in step 10, although the DE should be determined once for each lot of sorbent used, using the following procedure:

- Prepare and analyze a set of valeraldehyde oxazolidine standard solutions (step 9.a) and a set of working standards (step 10), including media blanks.
- Treating the working standards as unknowns, read the mass (µg) of valeraldehyde oxazolidine found in each working standard (W), and in the average media blank (B).
- Using the mass of valeraldehyde, µg, spiked onto the working standard (W_o) and the stoichiometric conversion factor of 2.13 between valeraldehyde and valeraldehyde oxazolidine, calculate the desorption efficiency:

$$DE = \frac{W - B}{W_o \cdot 2.13}$$

- Prepare a graph of DE vs. µg valeraldehyde recovered per sample, (W - B)/2.13.

Disclaimer: Mention of any company or product does not constitute endorsement by NIOSH. In addition, citations to websites external to NIOSH do not constitute NIOSH endorsement of the sponsoring organizations or their programs or products. Furthermore, NIOSH is not responsible for the content of these websites. All web addresses referenced in this document were accessible as of the publication date.

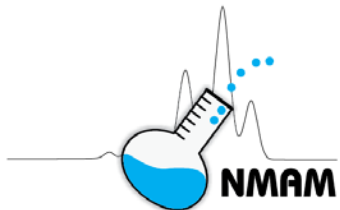

ORGANIC AND INORGANIC GASES by Extractive FTIR Spectrometry

3800

FORMULA: Table 1 MW: Table 1 CAS: Table 1 RTECS: Table 1

METHOD: 3800, Issue 2

EVALUATION: FULL

Issue 1: 15 March 2003
Issue 2: 13 January 2016

OSHA: Table 1
NIOSH: Table 1

PROPERTIES: Table 1

SYNONYMS: See example compounds in Table 1

| SAMPLING | MEASUREMENT |
|---|--|
| <p>SAMPLER: PORTABLE DIRECT-READING INSTRUMENT (with filter, if required)</p> <p>FLOW RATE: ~0.1 L/min to ~20 L/min (system-dependent)</p> <p>VOL-MIN: Instrument dependent -MAX: None</p> <p>PRESSURE: Extracted gases between 96.6 kPa and 103 kPa (725 mmHg and 795 mmHg) absolute</p> <p>TEMPERATURE: Extracted gases between 10 °C and 30 °C</p> <p>BLANKS: Nitrogen gas, or zero air</p> | <p>TECHNIQUE: EXTRACTIVE FOURIER TRANSFORM INFRARED (FTIR) SPECTROMETRY</p> <p>ANALYTE: See Table 1 (additional compounds may be identified/quantified according to data quality objectives and QA/QC requirements)</p> <p>ANALYTICAL FREQUENCIES: See Table 2 for example compounds</p> <p>CALIBRATION: Calibration gas standards</p> <p>IDENTIFICATION: Infrared spectra interpretation and computerized reference library searches</p> |
| ACCURACY | <p>RANGE: See Table 2 (dependent on compound and absorption path length)</p> <p>ESTIMATED LOD: See Table 2 for example values at 10 m absorption path length</p> <p>PRECISION (\bar{S}): See APPENDIX E</p> |
| <p>RANGE STUDIED: See APPENDIX E</p> <p>BIAS: See APPENDIX E</p> <p>OVERALL PRECISION (\hat{S}_{r^2}): See APPENDIX E</p> <p>ACCURACY: See APPENDIX E</p> | |

APPLICABILITY: The usefulness of FTIR techniques has been demonstrated in ambient air and combustion gas mixtures [1,2]. With the participation of an experienced analyst (see APPENDIX A), the method can be used for the characterization of workspace air containing mixtures of volatile organic and inorganic compounds. See Table 1 for examples.

INTERFERENCES: Overlap of infrared absorption features may affect the quantification of each compound. By appropriate use of multivariable least squares analyses, the analyst may be able to obtain accurate compound concentrations for overlapping compounds.

OTHER METHODS: This method is based on portions of EPA method 320 and its addendum [3], which describe the determination of gaseous compound concentrations by extractive FTIR spectrometry. Several compatible ASTM standards describing infrared techniques and terminology are also available [4,5,6,7].

REAGENTS:

1. Nitrogen gas or zero air, high purity or better.
2. Calibration transfer standard (CTS) gas, 2% accuracy or better. The proper concentration depends on both the compound used and the system absorption path length. For ethylene in nitrogen, a standard concentration leading to a concentration-path length product (CPP) of 100 ppm · m to 400 ppm · m is recommended. (For example, a standard of 10 ppm to 40 ppm ethylene in nitrogen is recommended for a 10 m absorption cell).
3. Liquid nitrogen* for cooling the infrared detector, if required.

*See SPECIAL PRECAUTIONS.

EQUIPMENT:

1. FTIR spectrometer system (source, interferometer, sample absorption cell, and detector) configured for absorption. A minimum instrumental linewidth (MIL) of 2 cm^{-1} or lower is recommended.
NOTE: A lower or higher MIL may be required or suitable for specific gas matrices. Choose internal absorption cell materials to minimize surface/analyte interactions.
2. Computer system with hardware, software, and required reference spectra for acquisition, storage, and analysis of sample spectra. (A data backup system is recommended.)
3. Sampling pump, 0.1 to 10 L/min, with appropriate particulate filters.
4. Non-reactive gas regulators and sample tubing.
5. Rotameters or other devices, 5% precision or better, for measuring flow rates of sample and calibration gases.
6. Temperature measurement and/or control equipment for all sampling system elements and IR absorption cell.
NOTE: Temperature control equipment required if ambient temperature $<10\text{ }^{\circ}\text{C}$ or $>30\text{ }^{\circ}\text{C}$.
7. Pressure gauge for measuring absolute gas pressure in absorption cell, 5% accuracy at 101.3 kPa (1 atm, 760 mmHg) absolute pressure.
8. For system tests (but not for normal operation): Vacuum pump and gauge capable of 13.3 kPa (100 mmHg) absolute pressure; mid-infrared attenuating filters (50% and 25%); impinger.

SPECIAL PRECAUTIONS: This method requires the use of compressed gases and/or cryogenic liquids and/or toxic chemicals. These materials are dangerous and should be handled only by experienced personnel and according to relevant safety standards. This method does not address all of the safety concerns associated with its use. It is the responsibility of the user to establish appropriate safety and health practices and to determine the applicability of regulatory limitations.

NOTE: Please refer to the appendices for explanations of the terminology used in this document (APPENDIX A) and several FTIR system tests, which must be completed before any testing is performed (APPENDIX B). Appendices C, D, and E provide (respectively) a general description of FTIR spectrometry, considerations for preparing reference libraries, and examples of calculations required for performance of this method.

PRETEST PROCEDURES:

The following procedures (steps 1 and 2) may be performed only by an experienced "analyst" (see APPENDIX A).

1. Verify that the FTIR system has been tested for wavenumber reproducibility, MIL, absorption path length, system response time, residual squared area (RSA), and detector linearity as described in APPENDIX B. If the system is new and/or has been recently assembled and/or has been recently serviced, perform and document results of the tests described in APPENDIX B before proceeding.
2. Prepare a test plan. The plan must include the following:
 - a. The proposed system configuration, including the absorption path length and integration time for sample spectra.
 - b. The data quality objectives, analytical regions, and expected LOD values for each analyte. See Table 2 and APPENDIX E for example values and calculations.
 - c. The names of all "operators" and "analysts" to be involved in the test. Analysts must be experienced in all aspects of the test procedures listed below and may perform any or all of the test procedures. Operators must be experienced in the performance of steps 3, 4, 5, 6, 7, 8, 9, 10, 11, 12, and 13 listed below and may perform *only* those portions of the test procedures.
 - d. Verification that the system configuration, existing RSA values, and related LOD values are consistent with the test's data quality objectives. (See APPENDIX E.)

The following procedures (steps 3, 4, 5, 6, 7, 8, 9, 10, 11, 12, and 13) may be performed by an experienced operator or analyst.

3. Activate the FTIR system according to the manufacturer's instructions. Allow sufficient time for the infrared source, the infrared detector, and (if required) the temperature control systems to stabilize.
4. Verify that the computer system is programmed to store interferograms; if the available data storage capacity is insufficient for storage of all interferograms, store single-beam spectra instead. Verify adequacy and performance of the (recommended) data backup system.
5. Bypassing the sampling system, flow nitrogen or zero air directly into the infrared absorption cell until a stable infrared response and moisture levels are reached. Record a background spectrum using an integration time equal to or greater than that planned for subsequent sample spectra.
6. Use the entire FTIR system (including all sampling components) to record an absorbance spectrum of a sample stream of nitrogen or zero air. Use the integration time planned for subsequent sample spectra. Verify that the sample flow rate meets or exceeds that specified in the system response time documentation. Examine the resulting "system zero" (SZ) spectrum and verify the absence of contaminants in the sampling system and infrared absorption cell. If contaminants are detected, clean or replace the appropriate sampling system components and/or infrared absorption cell and record a new SZ spectrum. If contaminants cannot be eliminated, the test results and LOD values may require revision/correction during the quality control procedures (see steps 14, 15, 16, and 17).

CALIBRATION:

7. Using the entire sampling system, acquire two or more pretest CTS spectra and use them to calculate the system absorption path length L_s (see APPENDIX B, section B1). Use the integration time planned for subsequent sample spectra. Verify that L_s is within 5% of the value quoted in the test plan. Verify that the sample temperature and pressure are within 10 °C to 30 °C and 96.6 kPa to 103 kPa (725 mmHg to 795 mmHg), respectively.
8. When possible, perform the following system checks before sampling. If necessary, they may be delayed until performance of the (post-testing) quality control procedures (see steps 14, 15, 16, and 17). If performed after sampling, the results of these procedures may require revision of the test results and LODs.

- a. LOD check. Using one of the SZ spectra, calculate the RSA values (see APPENDIX B, section B2) and LOD values (see Appendix E, section E1) in the analytical regions pertaining to the test analytes. Verify that the system path length (see APPENDIX B, section B1), current RSA values, and current LODs are consistent with the test's data quality objectives (see Appendix E, section E1).
- b. Wavenumber reproducibility check. Record a preliminary workspace air sample spectrum and perform the calculations described in Appendix B, section B4.

SAMPLING:

9. Using the integration time specified in the test plan, obtain samples and record infrared spectra of the desired workplace gases using the entire sampling system. The sampling location may be changed as desired. For tests of duration greater than 2 h, or if the FTIR system is moved during sampling, monitor the system's single-beam response level. If changes greater than 5% in non-absorbing regions of the single-beam spectrum occur, suspend sampling and record a new background spectrum (see step 5). Sample spectra must be acquired at each sampling location for a time period no less than the system response time (see the system test documentation).
10. Repeat step 6; acquire at least one posttest SZ spectrum of nitrogen or zero air; confirm the absence of sampling system contaminants.
11. Record at least one posttest CTS spectrum (see step 7); confirm that the system configuration and the system absorption path length (to within 5%) match those of the test plan.
12. (Optional.) Acquire a posttest background spectrum (see step 5).

SAMPLE ANALYSIS:

13. Using the analytical regions specified in the test plan, employ an appropriate mathematical analysis (see APPENDIX E) to determine preliminary analyte concentrations and their 3σ uncertainties from the sample spectra, reference spectra, absorption path length, and gas pressure.

NOTE: Reference spectra for all analytes must meet or exceed the QA/QC requirements of APPENDIX D. The reference library must include at least one wavenumber standard spectrum and at least one CTS spectrum. The sample absorption due to any analyte may not exceed the maximum CPP represented in the reference library for that compound.

QUALITY CONTROL:

The following procedures (steps 14, 15, 16, 17, and 18) may be performed only by an experienced analyst.

14. Using one of the SZ spectra, calculate the RSA and LOD values (see APPENDIX E) in the analytical regions pertaining to the test analytes. Verify that the system path length, current RSA values, and current LODs are consistent with the test's data quality objectives. Using a suitable workspace air spectrum, perform the wavenumber reproducibility and resolution tests described in APPENDIX B, sections B3 and B4. If either the wavenumber reproducibility or resolution results fail to meet the specifications, corrective actions are necessary (see step 17).
15. Perform qualitative and/or quantitative analyses of the pretest and posttest SZ spectra and confirm the absence of sampling system contaminants. If contaminants are found that possess significant absorbance in any analytical region, corrective actions may be necessary (see step 17). Perform qualitative and/or quantitative analyses of the pretest and posttest CTS spectra and confirm that the system absorption path length is within 5% of the value quoted in the test plan.
16. Verify that the reference spectra and results meet the data quality objectives of the test plan (see APPENDIX D). If they do not, corrective actions may be necessary (see step 17). Examine the results of the quantitative sample analysis (step 13) and verify some subset of them (including those with relatively high and relatively low concentrations) manually to ensure proper operation of analytical

program. (Techniques for generating spectra representing the analytes at the concentration indicated by the analysis — “scaled spectra,” as defined in APPENDIX A — are described in APPENDIX E. The analyst should generate such spectra and compare them, either visually or mathematically, to the indicated sample spectra.)

17. Corrective actions: If the results of steps 14, 15, and 16 indicate that the data quality objectives of the test plan have not been achieved, the analyst may perform one or more of the following actions:
- Averaging of sequential sample spectra to reduce the RSA.
 - Inclusion of contaminant reference spectra in the mathematical analysis.
 - Development of more accurate analyte or interferant reference spectra.
 - Inclusion of reference spectra for additional compounds in the mathematical analysis.
 - Exclusion from the mathematical analysis of analyte and/or interferant compounds that are clearly absent in the samples.
 - Deresolution or wavenumber adjustment of the reference spectral library to match that of the sample spectra (or vice versa).
 - Revision of the original data quality objectives (those included in the test plan) to levels supported by the test data.

NOTE: After performing any such corrective actions, the analyst must repeat steps 13, 14, 15, and 16 and reevaluate the LOD value for each analyte compound.

REPORTING:

18. Reporting requirements include the analyte and interferant concentrations, the concentration uncertainties, the FTIR spectrometer configuration, the sampling locations and conditions, the source(s) of the reference spectra, the CTS spectral analysis results, the results of QA/QC procedures, and certificates of analysis for all standard gases. Any variations of the test procedures and original data quality objectives from those included in the test plan should also be documented and reported. (Several of the terms used here are defined in APPENDIX A and described in the following appendices. In particular, see Table D1 for a description of the FTIR spectrometer configuration parameters.)

EVALUATION OF METHOD:

Field evaluations of extractive FTIR methods have been performed for many compounds (see, for example, references 1 and 2) according to EPA method 301 [8].

REFERENCES:

- [1] EPA [1993]. Fourier transform infrared (FTIR) method validation at a coal fired boiler [www3.epa.gov/ttnemc01/ftir/reports/r03.html].
- [2] Reagen WK, Wright BD, Krueger DJ, Plummer GM [1999]. Fourier transform infrared method validation at a carbon bed solvent recovery unit for four gaseous hydrocarbons. *Environ Sci Technol* 33(10):1752–1759.
- [3] EPA [2014]. Method 320 — Measurement of vapor phase organic and inorganic emissions by extractive FTIR spectroscopy [www3.epa.gov/ttn/emc/methods/method320.html].
- [4] ASTM [2012]. D6348-12e1: Standard test method for determination of gaseous compounds by extractive direct interface fourier transform infrared (FTIR) spectroscopy. West Conshohocken, PA: ASTM International [www.astm.org].
- [5] ASTM [2015]. D1356-15b: Standard terminology relating to sampling and analysis of atmospheres. West Conshohocken, PA: ASTM International [www.astm.org].
- [6] ASTM [2006]. E168-06: Standard practices for general techniques of infrared quantitative analysis (withdrawn 2015). West Conshohocken, PA: ASTM International [www.astm.org].

- [7] ASTM [2013]. E1252-98(2013)e1: Standard practice for general techniques for obtaining infrared spectra for qualitative analysis. West Conshohocken, PA: ASTM International [www.astm.org].
- [8] EPA [2014]. Method 301 — Field validation of pollutant measurement methods from various waste media [www3.epa.gov/ttn/emc/methods/method301.html].
- [9] EPA [1993]. EPA reference absorbance spectra; EPA reference spectra interferograms [www3.epa.gov/ttn/emc/ftir/data.html].
- [10] NIST [2016]. Quantitative infrared database [webbook.nist.gov/chemistry/quant-ir/].
- [11] EPA [2016]. Software tools and viewers [www3.epa.gov/ttn/emc/ftir/tools.html].
- [12] Griffiths PR, De Haseth JA [1986]. Fourier transform infrared spectrometry. New York: Wiley.
- [13] Hamilton WC [1964]. Method of least squares and theory of linear hypotheses. In: Statistics in physical science; estimation, hypothesis testing, and least squares. New York: Ronald Press Co., pp. 124–145.
- [14] Plummer GM, Reagen WK [1996]. An examination of a least squares fit FTIR spectral analysis method. Unpublished paper (No. 96-WA65.03) presented at the 89th Annual Meeting of the Air and Waste Management Association, Nashville, TN, June 23–28.
- [15] EPA [2012]. EPA traceability protocol for assay and certification of gaseous calibration standards. Research Triangle Park, NC: U.S. Environmental Protection Agency, Office of Research and Development, National Risk Management Research Laboratory, EPA/600/R-12/531 [cfpub.epa.gov/si/si_public_record_report.cfm?dirEntryId=245292].

METHOD WRITTEN BY:

Grant M. Plummer, Ph.D. (Rho Squared), William K. Reagen, Ph.D. (3M), and Perry W. Logan (3M).

DISCLAIMER: Mention of any company or product does not constitute endorsement by NIOSH. In addition, citations to websites external to NIOSH do not constitute NIOSH endorsement of the sponsoring organizations or their programs or products. Furthermore, NIOSH is not responsible for the content of these websites. All web addresses referenced in this document were accessible as of the publication date.

Table 1. Representative volatile compounds and chemical data

| Name | Synonyms* | Formula | MW [†] | CAS No. | RTECS No. | BP (°C) [†] | VP at 20 °C (kPa) [†] | Exposure Limits (OELs)* | |
|-------------------|--|---|-----------------|-----------|-----------|----------------------|-------------------------------------|---|---|
| | | | | | | | | NIOSH | OSHA |
| Acetone | Dimethyl ketone, Ketone propane, 2-Propanone | (CH ₃) ₂ CO | 58.1 | 67-64-1 | AL3150000 | 56 | 24 | TWA 250 ppm (590 mg/m ³) | TWA 1000 ppm (2400 mg/m ³) |
| Ammonia | Anhydrous ammonia, Aqua ammonia, Aqueous ammonia | NH ₃ | 17.0 | 7664-41-7 | BO0875000 | -33 | 1.01 × 10 ³ (26 °C) | TWA 25 ppm (18 mg/m ³) ST 35 ppm (27 mg/m ³) | TWA 50 ppm (35 mg/m ³) |
| Benzene | Benzol, Phenyl hydride | C ₆ H ₆ | 78.1 | 71-43-2 | CY1400000 | 80 | 10 | Ca TWA 0.1 ppm ST 1 ppm | [1910.1028] TWA 1 ppm ST 5 ppm |
| 2-Butanone | Ethyl methyl ketone, MEK, Methyl acetone, Methyl ethyl ketone | CH ₃ COCH ₂ CH ₃ | 72.1 | 78-93-3 | EL6475000 | 80 | 10.5 | TWA 200 ppm (590 mg/m ³) ST 300 ppm (885 mg/m ³) | TWA 200 ppm (590 mg/m ³) |
| Carbon disulfide | Carbon bisulfide | CS ₂ | 76.1 | 75-15-0 | FF6650000 | 46 | 48 (25 °C) | TWA 1 ppm (3 mg/m ³) ST 10 ppm (30 mg/m ³) [skin] | TWA 20 ppm C 30 ppm 100 ppm (30 min maximum peak) |
| Ethylene oxide | Dimethylene oxide; 1,2-Epoxyethane; Oxirane | C ₂ H ₄ O | 44.1 | 75-21-8 | KX2450000 | 11 | 146 | Ca TWA <0.1 ppm (0.18 mg/m ³) C 5 ppm (9 mg/m ³) [10 min per day] | [1910.1047] TWA 1 ppm 5 ppm [15 min excursion] |
| Formaldehyde | Methanal, Methyl aldehyde, Methylene oxide | H ₂ CO | 30.0 | 50-00-0 | LP8925000 | -19.5 [§] | 519 [†] (3890 mmHg, 25 °C) | Ca TWA 0.016 ppm C 0.1 ppm [15 min] | [1910.1048] TWA 0.75 ppm ST 2 ppm |
| n-Hexane | Hexane, Hexyl hydride, normal-Hexane | CH ₃ (CH ₂) ₄ CH ₃ | 86.2 | 110-54-3 | MN9275000 | 69 | 17 | TWA 50 ppm (180 mg/m ³) | TWA 500 ppm (1800 mg/m ³) |
| Hydrogen fluoride | Anhydrous hydrogen fluoride; Aqueous hydrogen fluoride (i.e., Hydrofluoric acid); HF-A | HF | 20.0 | 7664-39-3 | MW7875000 | 20 | 122 (25 °C) | TWA 3 ppm (2.5 mg/m ³) C 6 ppm (5 mg/m ³) [15 min] | TWA 3 ppm |

See footnotes at end of table.

(Continued)

Table 1 (Continued). Representative volatile compounds and chemical data

| Name | Synonyms* | Formula | MW [†] | CAS No. | RTECS No. | BP (°C) [†] | VP at 20 °C (kPa) [†] | Exposure Limits (OELs)* | |
|---------------------|---|--|--------------------|------------|-----------|-------------------------|--|--|---|
| | | | | | | | | NIOSH | OSHA |
| Methanol | Carbinol, Columbian spirits, Methanol, Pyroligneous spirit, Wood alcohol, Wood naphtha, Wood spirit | CH ₃ OH | 32.0 | 67-56-1 | PC1400000 | 65 | 12.3 | TWA 200 ppm (260 mg/m ³) ST 250 ppm (325 mg/m ³) [skin] | TWA 200 ppm (260 mg/m ³) |
| Methylene chloride | Dichloromethane, Methylene dichloride | CH ₂ Cl ₂ | 84.9 | 75-09-2 | PA8050000 | 40 | 47.4 | Ca | TWA 25 ppm ST 125 ppm |
| Nitrous oxide | Dinitrogen monoxide, Hyponitrous acid anhydride, Laughing gas | N ₂ O | 44.0 | 10024-97-2 | QX1350000 | -88.5 | 5.06 × 10 ³ | TWA 25 ppm (46 mg/m ³) (TWA over the time exposed) [Note: REL for exposure to waste anesthetic gas.] | |
| Styrene | Ethenyl benzene, Phenylethylene, Styrene monomer, Styrol, Vinyl benzene | C ₆ H ₅ CH=CH ₂ | 104.1 [†] | 100-42-5 | WL3675000 | 145 | 0.67 | TWA 50 ppm (215 mg/m ³) ST 100 ppm (425 mg/m ³) | TWA 100 ppm C 200 ppm 600 ppm (5 min maximum peak in any 3 h) |
| Sulfur dioxide | Sulfurous acid anhydride, Sulfurous oxide, Sulfur oxide | SO ₂ | 64.1 | 7446-09-5 | WS4550000 | -10 | 330 | TWA 2 ppm (5 mg/m ³) ST 5 ppm (13 mg/m ³) | TWA 5 ppm (13 mg/m ³) |
| Tetrafluoroethylene | Tetrafluoroethene; Perfluoroethylene; Perfluoroethene; TFE [‡] | F ₂ C=CF ₂ | 100.0 [‡] | 116-14-3 | KX4000000 | -75.9 [§] | 3.27 × 10 ^{3‡} (24500 mmHg, 25 °C) | | |
| Tetrahydrofuran | Diethylene oxide; 1,4-Epoxybutane; Tetramethylene oxide; THF | C ₄ H ₈ O | 72.1 | 109-99-9 | LU5950000 | 66 | 19.3 | TWA 200 ppm (590 mg/m ³) ST 250 ppm (735 mg/m ³) | TWA 200 ppm (590 mg/m ³) |

See footnotes at end of table.

(Continued)

Table 1 (Continued). Representative volatile compounds and chemical data

| Name | Synonyms* | Formula | MW [†] | CAS No. | RTECS No. | BP (°C) [†] | VP at 20 °C (kPa) [†] | Exposure Limits (OELs)* | |
|---------------------|---|---|-----------------|----------|-----------|----------------------|-----------------------------------|--|---|
| | | | | | | | | NIOSH | OSHA |
| Toluene | Methyl benzene, Methyl benzol, Phenyl methane, Toluol | C ₆ H ₅ CH ₃ | 92.1 | 108-88-3 | XS5250000 | 111 | 3.8 (25 °C) | TWA 100 ppm (375 mg/m ³) ST 150 ppm (560 mg/m ³) | TWA 200 ppm C 300 ppm 500 ppm (10 min maximum peak) |
| Trichloroethylene | Ethylene trichloride, TCE, Trichloroethene, Trilene | ClCH=CCl ₂ | 131.4 | 79-01-6 | KX4550000 | 87 | 7.8 | Ca | TWA 100 ppm C 200 ppm 300 ppm (5 min maximum peak in any 2 h) |
| Vinylidene fluoride | Difluoro-1,1-ethylene; 1,1-Difluoroethene; 1,1-Difluoroethylene; Halocarbon 1132A; VDF; Vinylidene difluoride | F ₂ C=CH ₂ | 64.0 | 75-38-7 | KW0560000 | -83 | 3.57 ×10 ^{3*} (35.2 atm) | TWA 1 ppm C 5 ppm [use 1910.1017] | |
| <i>m</i> -Xylene | 1,3-Dimethylbenzene; meta-Xylene; <i>m</i> -Xylol | C ₆ H ₄ (CH ₃) ₂ | 106.2 | 108-38-3 | ZE2275000 | 139 | 0.8 | TWA 100 ppm (435 mg/m ³) ST 150 ppm (655 mg/m ³) | TWA 100 ppm (435 mg/m ³) |
| <i>o</i> -Xylene | 1,2-Dimethylbenzene; ortho-Xylene; <i>o</i> -Xylol | C ₆ H ₄ (CH ₃) ₂ | 106.2 | 95-47-6 | ZE2450000 | 144 | 0.7 | TWA 100 ppm (435 mg/m ³) ST 150 ppm (655 mg/m ³) | TWA 100 ppm (435 mg/m ³) |
| <i>p</i> -Xylene | 1,4-Dimethylbenzene; para-Xylene; <i>p</i> -Xylol | C ₆ H ₄ (CH ₃) ₂ | 106.2 | 106-42-3 | ZE2625000 | 138.4 | 0.9 | TWA 100 ppm (435 mg/m ³) ST 150 ppm (655 mg/m ³) | TWA 100 ppm (435 mg/m ³) |

*Source: NIOSH Pocket Guide to Chemical Hazards [www.cdc.gov/niosh/npg/]. Date accessed: February 2016.

[†]Source: International Chemical Safety Cards (ICSC) [www.cdc.gov/niosh/ipcs/]. Date accessed: February 2016.

[‡]Source: PubChem [pubchem.ncbi.nlm.nih.gov/]. Date accessed: February 2016.

[§]Source: Haynes WM, Lide DR, Bruno TJ [2013]. CRC handbook of chemistry and physics: a ready-reference book of chemical and physical data. 94th ed. Boca Raton, FL: CRC Press.

Table 2. Representative infrared data for the compounds of Table 1

| Compound | Analytical Region (cm ⁻¹) | Reference Spectrum Filename* | LOD at 10 m [†] (ppm) | Maximum concentration at 10 m [‡] (ppm) | Maximum RSA [§] (cm ⁻¹) | Reference Spectrum Source |
|---------------------|---------------------------------------|------------------------------|--------------------------------|--|--|---------------------------|
| Acetone | 1163 to 1265 | 192mav01.spc | 0.95 | 148 | 0.0211 | EPA** |
| Ammonia | 998 to 1131 | nh3mav01.spc | 0.77 | 470 | 0.0363 | 3M ^{††} |
| Benzene | 3000 to 3150 | 015mav01.spc | 0.32 | 149 | 0.036 | EPA** |
| 2-Butanone | 1127 to 1235 | mekmav01.spc | 0.27 | 463 | 0.0233 | 3M ^{††} |
| Carbon disulfide | 2109 to 2200 | 028mav01.spc | 0.13 | 151 | 0.0123 | EPA** |
| Ethylene oxide | 3059 to 3070 | 084mav01.spc | 0.11 | 138 | 0.0025 | EPA** |
| Formaldehyde | 2727 to 2844 | 087bb.spt | 0.4 | 1125 | 0.0267 | EPA** ^{‡‡} |
| <i>n</i> -Hexane | 2778 to 3051 | 095mav01.spc | 0.1 | 150 | 0.0639 | EPA** |
| Hydrogen fluoride | 4034 to 4206 | 21hfrav | 0.93 | 15.8 | 0.15 | 3M ^{††} |
| Methanol | 941 to 1100 | 104mav01.spc | 0.28 | 151 | 0.0447 | EPA** |
| Methylene chloride | 701 to 789 | 117mav01.spc | 0.31 | 150 | 0.062 | EPA** |
| Nitrous oxide | 1226 to 1333 | n2omav01.spc | 0.36 | 904 | 0.0301 | 3M ^{††} |
| Styrene | 738 to 944 | 147mav01.spc | 1.84 | 150 | 0.0363 | EPA** |
| Sulfur dioxide | 1290 to 1410 | so2.spc | 0.35 | ~200 ^{§§} | 0.1394 | NIST ^{§§} |
| Tetrafluoroethylene | 1080 to 1215 | tfemav05.spc | 0.17 | 25.7 | 0.093 | 3M ^{††} |
| Tetrahydrofuran | 2750 to 3085 | thf405.spc | 0.18 | 41 | 0.0782 | 3M ^{††} |
| Toluene | 701 to 768 | tolmav01.spc | 1.16 | 463 | 0.0499 | EPA** |
| Trichloroethylene | 762 to 966 | tcemav01.spc | 0.43 | 464 | 0.1071 | 3M ^{††} |
| Vinylidene fluoride | 1080 to 1215 | dfemav05.spc | 0.21 | 25.7 | 0.093 | 3M ^{††} |
| <i>m</i> -Xylene | 782 to 805 | 172mav01.spc | 1.36 | 146 | 0.0377 | EPA** |
| <i>o</i> -Xylene | 709 to 781 | 171mav01.spc | 0.65 | 150 | 0.0444 | EPA** |
| <i>p</i> -Xylene | 749 to 840 | 173mav01.spc | 1.17 | 151 | 0.0561 | EPA** |

*Used in LOD calculations; averaged spectra from the quoted libraries; data available from the authors.

[†]Approximate LOD for a 10 m absorption path length. Typical values of the RSA, quoted analytical regions, and quoted reference spectral data were used to calculate the LOD as described in Equation E1. Note: The LOD may vary from laboratory to laboratory, analyst to analyst, instrument to instrument, and day to day. Therefore, any determination of this value should be performed under the same conditions used for sample analysis and reported only with those analyses. It is stressed that the values below are only conservative estimates of the expected performance of this method.

[‡]The maximum ppm · m value available for the compound in the quoted reference spectrum source.

[§]Maximum RSA in the specified analytical regions consistent with the quoted LOD values. See APPENDIX E, section E1.

**See reference 9. Average absorbance and accepted standard concentration values for the low-concentration pairs of spectra were used. Interferograms were truncated to 0.5 cm⁻¹ resolution and triangular apodization was employed.

^{††}Data available from the authors.

^{‡‡}From EPA reference spectra recorded at 100 °C [9].

^{§§}NIST quantitative infrared database [10]. The quoted maximum concentration for sulfur dioxide is based on linearity studies of 0.5 cm⁻¹ resolution spectra with triangular apodization. Nonlinear absorbance leads to errors of less than 10% at 1000 ppm · m.

APPENDIX A. TERMINOLOGY

absorbance — in terms of the incident intensity I_0 and transmitted intensity I , the absorbance A is given by $A = -\log(I/I_0)$. From a pair of FTIR single-beam spectra B (the background spectrum) and S (the sample spectrum), the sample absorbance for each wavenumber value (with index i) in the spectra is approximated by $A_i = -\log(I_{Si}/I_{Bi})$.

absorbance linearity — a characteristic of (ideal) absorbance spectrum; for such a spectrum, the measured absorbance is described by Beer's law (Equation C1).

absorption band — a contiguous wavenumber region of a spectrum (equivalently, a contiguous set of absorbance spectrum data points) in which the absorbance passes through a maximum or a series of maxima.

absorption cell — a structure that contains a fluid sample, but allows light to pass through a sample at known temperature, pressure, and absorption path length.

absorption path length — the distance, measured in the direction of propagation of the beam of radiant energy, between the surface of the specimen on which the radiant energy is incident and the surface of the specimen from which it is emergent.

absorptivity — a measure of the fraction of the incident infrared radiation that is absorbed by a particular compound per molecule and per absorption path length; see Equation C1.

analyst — a person familiar with and experienced in performance of all aspects of this FTIR-based method. Analysts may perform any portion(s) of the method and must perform certain portions of the method (see also "operator").

analyte — a compound whose concentrations in a sample is of interest and is to be accurately quantified (see also "interferant").

analytical region — a contiguous wavenumber region (equivalently, a contiguous set of absorbance spectrum data points) used in the quantitative analysis for one or more analytes.

NOTE: The quantitative result for a single analyte may be based on data from more than one analytical region.

aperture — an optical device that physically restricts the diameter of the optical beam.

apodization — modification of the interferogram through its multiplication by a weighing function whose magnitude varies with the position of the interferometer's moving element.

background spectrum — the single-beam spectrum obtained with all system components and without sample present (or in the presence of a non-absorbing gas replacing the sample).

baseline — any line (or smooth function of wavenumber) drawn on an absorption spectrum to establish a reference point that represents a function of the radiant power incident on a sample at a given wavelength.

Beer's law — the direct proportionality of the absorbance of a compound in a homogeneous sample to its concentration. See Equation C1, which also describes the more general case of gas mixtures.

calibration transfer standard (CTS) gas — a gas standard of a compound used to measure the sample absorption path length; see step 7, step 11, APPENDIX B (section B1), and APPENDIX D (section D5).

cm^{-1} — see "wavenumber."

compound — a substance possessing a distinct, unique molecular structure.

concentration — the quantity of a compound contained in a unit quantity of sample. The unit "ppm" (number, or mole, basis) is recommended and is equivalent to the volume basis for ideal gases.

concentration-path length product (CPP) — the mathematical product of concentration of the species and the absorption path length. For reference spectra, this is a known quantity; for sample spectra, it is the quantity directly determined from Beer's law. The unit "parts per million · meters" ($\text{ppm} \cdot \text{m}$) is recommended.

data quality objectives — parameters pertaining to a certain application of this method, including the estimated LOD values for each compound.

deresolve — to form spectra of lower resolution (higher full-width-at-half-maximum) from spectra of higher resolution (lower full-width-at-half-maximum); see reference 11 for a deresolution program.

- detector linearity — a characteristic of an (ideal) IR detector; for such a detector, the measured detector output voltage, when plotted against the total IR in a broadband IR signal incident on the detector, would form a straight line.
- double-beam spectrum — a transmittance or absorbance spectrum derived by dividing the sample single-beam spectrum by the background spectrum.
NOTE: The term “double-beam” is used elsewhere to denote a spectrum in which the sample and background interferograms are collected simultaneously along physically distinct absorption paths. Here, the term denotes a spectrum in which the sample and background interferograms are collected at different times along the same absorption path.
- extractive — the type of spectroscopy that includes extracting and transporting a sample stream from gases at a certain location to an absorption cell and isolating the sample in the absorption cell for analysis. Other types of spectroscopy in which the sample is not isolated in an absorption cell include “remote”, “open path”, and “local open path” techniques.
- FFT (fast Fourier transform) — a discrete (digital) approximation to an FT (Fourier transform; see below) involving the factoring of the original data into sparse matrices containing mostly zeros.
- filter — (1) A device, made of inert materials, that physically removes solid and liquid phase particles from a gas stream. (2) An optical device that transmits some fraction of the radiation incident on it; “neutral density” and “mesh” filters transmit an approximately constant fraction of the incident radiation at all wavelengths over a specified wavelength range.
- frequency, ν — the number of cycles per unit time; for light, $\nu = c / \lambda$, where c is the speed of light and λ is the light’s wavelength. Unlike the speed and wavelength, which are medium-dependent, the frequency of light is independent of the medium through which the light travels. The term “frequency” is often used to denote the wavenumber (w , cm^{-1}) in FTIR spectroscopy because (in a given medium) the wavenumber is proportional to the frequency. (See APPENDIX C, section C4, and “wavenumber” in this appendix.)
- FT (Fourier transform) — the mathematical process for converting an analytical (non-discrete) amplitude-time function to an amplitude-frequency function, or vice versa.
- FTIR (Fourier transform infrared) spectrometer — an analytical system that employs a source of mid-infrared radiation, an interferometer, an enclosed sample cell of known absorption path length, an infrared detector, optical elements that transfer infrared radiation between components, and a computer system. The time-domain detector response (interferogram) is processed by a Fourier transform to yield a representation of the infrared power vs. infrared frequency. See Figures C1 and C2.
- FTIR spectrometry — use of an FTIR system to perform quantitative measurements.
- FTIR system — the combination of an FTIR spectrometer and a sample interface.
- FTIR system configuration — the set of parameters required to reproduce, as closely as possible, results from a particular FTIR system at a later time. This set includes (at least) the nominal MIL, the absorption path length, the apodization function, the gas temperature, the gas pressure, the zero filling factor, the measured wavenumbers of specific water absorption bands, the sources of the reference library spectra, the integration time, the detector type and serial number, the detector gain (including hardware and software settings).
- FTIR system response time — the minimum time required for the output of an FTIR system to accurately reflect a sudden change in the sample gas composition; see APPENDIX B, section B5.
- full-width-at-half-maximum (FWHM) — for a single, symmetric absorption band, the full width of the band in wavenumbers (cm^{-1}) between its 50% relative maximum absorption levels.
- impinger — a sample collection device, constructed of inert materials, that passes a gas stream through a liquid phase.
- infrared detector — a device that (ideally) produces a voltage proportional to the total infrared power incident on it. Examples are 1) the mercury-cadmium-telluride (MCT) detector, which requires cooling (and is often cooled to liquid nitrogen temperature) and 2) the deuterated triglycine sulfate (DTGS) detector, often operated at ambient temperature.

- infrared source — a device that emits a pattern, stable in intensity and wavelength profile, of infrared radiation over a wide range of infrared wavelengths. High temperature filaments or ceramic elements, in conjunction with appropriate focusing optics, are often employed.
- integration time — the total time over which the interferometric results of single scans are averaged to produce an interferogram (and its subsequent single- and double-beam spectra). Most software packages allow selection of the number of scans rather than the integration time. The integration time is approximately equal to (but is always less than) the time interval over which the selected number of scans is actually executed.
- interferant — a compound whose presence in a sample spectrum must be taken into account to accurately determine one or more analyte concentrations, but whose concentration need not be accurately determined.
- interferogram — record of the IR detector's response to the modulated component of the interference signal measured as a function of retardation.
- interferometer — device that divides a beam of radiant energy into two or more paths, generates an optical path difference between the beams, and recombines them in order to produce repetitive interference maxima and minima as the optical retardation is varied.
- least squares fitting (LSF) algorithm — a calculation whereby one or more compound concentrations are estimated from a sample spectrum by minimizing the squared error in Beer's law within a defined analytical region (see Equations C1, C2, C3, C4, C5, and C6).
- limit of detection (LOD, ppm) — for a defined FTIR system configuration and sample matrix, an estimate of the lowest detectable concentration of a specific analyte based on the FTIR system's RSA and the analyte's integrated absorbance for a selected analytical region.
- line — see "absorption band."
- linewidth — see "full-width-at-half-maximum" and "minimum instrumental linewidth."
- metering valve — a gas valve allowing reproducible adjustments of a gas stream flow rate on the order of 2% of the valves full flow rate.
- mid-infrared — the region of the electromagnetic spectrum from approximately 400 cm^{-1} to 5000 cm^{-1} .
- minimum instrumental linewidth (MIL) — for a given FTIR spectrometer and FTIR system configuration, the minimum measured FWHM for any absorption band. In wavenumbers, the MIL is often estimated as the reciprocal of the retardation expressed in cm. The MIL depends on the choice of apodization function and is often larger than the MIL estimated from the retardation.
- multi-pass cell — an absorption cell that uses mirrors to pass the infrared radiation through the gas sample more than once; this leads to an absorption path length larger than the physical length of the cell (see also "White cell").
- operator — a person familiar with and experienced in performance of only some aspects of this FTIR-based method. Operators may perform many portions of this method, but specific portions of the method must be performed by an "analyst."
- peak — see "absorption band."
- qualitative analysis — examination of sample spectra to determine the presence or absence of particular compounds in a sample.
- quantitative analysis — estimation of the actual concentrations of a specific set of compounds using a specific set of analytical regions.
- reference spectra — absorption spectra of gases with known chemical compositions, recorded at a known absorption path length, which are used in the quantitative analysis of gas samples.
- residual squared area (RSA) — a measure of the noise (random and systematic) and/or spectral artifacts for an absorbance spectrum in some analytical region; see APPENDIX B, section B2 for a mathematical definition. The RSA can be used to estimate the LOD for a given compound measured with a given FTIR system configuration.
- retardation — optical path difference between two beams in an interferometer; also known as "optical path difference" or "optical retardation." In the case of a standard Michelson interferometer, the retardation is simply twice the distance moved by a mirror in the interferometer during a scan.

rotameter — a device indicating the volumetric flow rate of a gas by the vertical displacement of an object suspended by the gas stream.

sample interface — that part of the FTIR system that comes in contact with the sample and/or calibration gases. It includes the sample probe, sample filter, sample line, sample pump, gas valves, internal surfaces of the absorption cell, pressure gauge, sample rotameter, the vent lines, and the calibration components (gas cylinders, regulators, and rotameters).

sampling location — the point in space at which sample gases enter the sample interface.

scaling — application of a multiplicative factor to the absorbance values in a spectrum.

scan — digital representation of the detector output obtained during one complete motion of the interferometer's moving assembly or assemblies.

single-beam spectrum — Fourier-transformed interferogram, representing the relative detector response vs. wavenumber.

NOTE: The term "single-beam" is used elsewhere to denote any spectrum in which the sample and background interferograms are recorded on the same physical absorption path; such usage differentiates such spectra from those generated using interferograms recorded along two physically distinct absorption paths (see "double-beam spectrum" above). Here, the term applies (for example) to the two spectra used directly in the calculation of transmittance and absorbance spectra of a sample.

system zero (SZ) spectrum — the absorbance spectrum of a non-absorbing gas (nitrogen or zero air) acquired using those portions of the sampling interface used to acquire actual sample gases.

transmittance, T — the ratio of radiant power transmitted by the sample to the radiant power incident on the sample. Estimated in FTIR spectroscopy by forming the ratio of the single-beam sample and background spectra; often presented as $\%T$ ($100 \times T$) in spectral representations.

uncertainty — a mathematical quantity determined in an LSF procedure, used to estimate the likely error in the determination of the sample concentration in a procedure; see Equations C1, C2, C3, C4, C5, and C6.

wavelength λ , — the physical distance between successive maxima in the electromagnetic waves that comprise light. The wavelength and speed of light depend on the medium through which the light travels.

wavenumber, w — the reciprocal of the wavelength, also the number of wavelengths of light per unit length, usually expressed in the units cm^{-1} . As is true of both the speed and wavelength of light, the wavenumber is dependent on the medium through which the light travels. (See APPENDIX C, section C4 and "frequency" in this appendix.)

wavenumber adjustment — reassignment of the cm^{-1} values associated with single- and/or double-beam spectra. Adjustments may be made locally by shifting or stretching the wavenumber scale, or globally stretched by changing the laser wavenumber during the FFT.

White cell — alternate name for a multi-pass absorption cell (see "multi-pass" above) indicating its inventor.

zero filling — the addition of zero-valued points to the end of a measured interferogram. In most computer programs, specification of a zero filling "factor" of N results in an interferogram with N times as many points as the original interferogram.

APPENDIX B. SYSTEM TESTS

These procedures must be conducted at least once on new or significantly altered (by replacement of components, dis- and reassembly, etc.) systems. The tests described in sections B2 and B4 must also be repeated during either the pretest preparations or quality assurance procedures. In all cases, activate the FTIR system and allow sufficient time for the infrared source, the infrared detector, and (if required) the temperature control systems to stabilize before proceeding.

B1. Absorption Path Length

Obtain one or more absorbance spectra of a CTS gas (ethylene at 200 ppm · m to 300 ppm · m is recommended) at the gas temperature and pressure of a reference CTS spectrum of the same compound. For each spectrum, calculate the indicated absorption path length as

$$L_S = \frac{L_R P_R A_S}{P_S A_R}, \quad (\text{Equation B1})$$

where: L_S = path length indicated by the sample CTS spectrum (m),

L_R = path length of the reference CTS spectrum (m),

A_S = area of the sample CTS spectrum (cm^{-1}),

A_R = area of the reference CTS spectrum (cm^{-1}),

P_S = pressure of the sample CTS spectrum (kPa), and

P_R = pressure of the reference CTS spectrum (kPa).

When multiple CTS spectra are available, assign to L_S the mean of the single-spectrum L_S results. The reference CTS spectrum path length and concentration used must be based on multiple, high-quality gas standards and physical length measurements (see APPENDIX D, section D5). The analyst must document criteria for the selection of the analytical region and any baseline correction procedures employed.

B2. Residual Squared Area

NOTE: If the following calculations are performed during testing or as part of the QC procedures (steps 14, 15, 16, and 17), perform them using a workspace air spectrum instead of the "water vapor (absorbance) spectrum" described in the two paragraphs below.

Use the integration time selected for field testing in recording the spectra described below. Record a background spectrum of dry nitrogen gas or zero air. Using a suitable impinger, humidify the nitrogen or zero air stream and record a single-beam spectrum at an absolute pressure between 96.6 kPa and 103 kPa (725 mmHg and 795 mmHg). Form the absorbance spectrum of this water vapor sample from the single-beam spectra. Assign the spectrum a unique filename and save it for the calculations described below.

From this water vapor spectrum, subtract a scaled spectrum (see APPENDIX A) formed from the water vapor reference spectrum to be used in subsequent quantitative analyses. The scaling factor may be varied to minimize the absorbance in the resulting difference spectrum in the various analytical regions to be used in the analyses. Subtract a constant offset, a linear function, or a quadratic function from the difference spectrum in each analytical region to form a residual spectrum R for each region. For each residual spectrum R with discrete absorbance value R_i for wavenumber $i = p$ to q , in the wavenumber range w_p to w_q , the RSA, A_{RS} , is defined as:

$$A_{RS} = \frac{w_p - w_q}{q - p + 1} \sqrt{\sum_{i=p}^{i=q} \frac{R_i^2}{q - p}}. \quad (\text{Equation B2})$$

The RSA has the dimensions (cm^{-1}) and serves as a measure of the integrated absorbance of spectral noise and water subtraction artifacts over the analytical region. The RSA is compared to the total absorbance of a compound in the same region to estimate the LOD for the compound in that region (see APPENDIX D, section D9 and APPENDIX E, section E1).

The calculation described above assumes that water is the only significant infrared absorber in the samples besides the analytes and that only one analyte absorbs in any analytical region. If other analytes or interferants are present, a more conservative RSA may be estimated by adding the absorbance of the additional compounds to the difference spectrum using a set of suitable reference spectra, then subtracting their absorbance using a *different* set of reference spectra.

B3. Minimum Instrumental Linewidth

Evacuate the absorption cell to a pressure below 13.3 kPa (100 mmHg) and record a background spectrum. Obtain a workspace air sample at an absolute pressure of approximately 40 kPa (300 mmHg). Record the absorbance spectrum of this low-pressure sample. Measure at the FWHM linewidth, in cm^{-1} , of at least two isolated water vapor lines (for example, the lines near 1918 cm^{-1} and 2779 cm^{-1}). The MIL is the mean of these FWHM measurements.

B4. Wavenumber Reproducibility

NOTE: If this calculation is performed during testing or as part of the QC procedures (see steps 6 and 10), perform these determinations using a workspace air spectrum instead of the water vapor absorbance spectrum described in section B2.

Using a water vapor spectrum recorded as described in section B2, determine the center wavenumber values w_{s1} and w_{s2} of two isolated water vapor absorption features; the peaks near 1918 cm^{-1} and 2779 cm^{-1} are suggested, though any other pair of isolated lines separated by 500 cm^{-1} or more is suitable. Compare these results to those center wavenumber values w_{r1} and w_{r2} and for the same absorbance features in the water vapor wavenumber standard associated with the reference library to be used in quantitative analyses as follows: Calculate the wavenumber reproducibility, R_{wi} , in cm^{-1} for each of the two absorption bands as

$$R_{wi} = |w_{ri} - w_{si}|, \quad (\text{Equation B3})$$

for $i = 1, 2$.

Compare the maximum of these two values to the MIL for the FTIR system (see section B3). If the wavenumber reproducibility to MIL ratio exceeds 2%, adjustment of the wavenumber scale for the sample spectra may be required.

Mathematical wavenumber adjustments may be made locally by shifting or stretching the wavenumber scale, or globally stretched by changing the laser wavenumber during the FFT. However, large shifts (on the order of 5% or more of the MIL) indicate that the system requires physical adjustments, such as realignment of the laser system responsible for control of the interferometer's moving element. In addition, mathematical wavenumber adjustments require some sort of interpolation procedure in conjunction with the quantitative spectral analysis, and those procedures may result in spectral mismatches whose effects on the accuracy of the analysis are not easily quantified.

The necessity of such wavenumber adjustments depends, in part, on the widths of the absorption peaks of the compounds involved in the spectral analysis. Because many of the absorption bands of water — a nearly ubiquitous interferant in workspace air IR analysis — are very narrow, an accurate analysis usually requires the relatively stringent limits placed above on the wavenumber reproducibility to MIL ratio. However, it is possible to obtain accurate results when this ratio exceeds the recommended limit, especially when only broad absorbance features are actually employed. The analyst may choose to approve analytical results obtained when this ratio exceeds the recommended limit.

B5. System Response Time

Direct nitrogen or zero air through the entire sample interface and record spectra at approximately 30 s intervals. Abruptly replace the nitrogen or zero air gas flow with CTS gas and continue to record spectra. The system response time is the subsequent time required for the FTIR system to generate an absorbance spectrum in which the CTS compound's calculated concentration reaches 95% of the final (stable) concentration value indicated in later spectra.

B6. Detector Linearity

For the chosen optical configuration, attenuate the power incident on the detector by either 1) modifying the aperture setting or 2) placing filters (neutral density or mesh) in the infrared beam path (see Figure C1). At approximately 100%, 50%, and 25% of the system full IR power level, collect pairs of background and CTS spectra. Compare the areas of the CTS bands for the three spectra and verify that they are equal to within 5% of their mean value. If they are not, apply software linearization corrections to the interferometric data according to the manufacturer's instructions. If this option is unavailable, it is necessary to either 1) characterize the system non-linearity and/or apply appropriate concentration corrections or 2) operate the system with attenuation sufficient to ensure linear detector response.

APPENDIX C. GENERAL DESCRIPTION OF FTIR SPECTROMETRY

C1. FTIR Spectrometer Components

Figure C1 illustrates the basic FTIR spectrometer configuration required for gas phase analyses. The infrared radiation emitted by the infrared (IR) source contains energy at all wavelengths between 2.0 μm and 20 μm ; this is the portion of the electromagnetic spectrum usually referred to as the “mid-infrared.” In the units typically employed in FTIR spectroscopy (wavenumbers, or cm^{-1}), this is the wavenumber range 5000 cm^{-1} to 500 cm^{-1} . The IR radiation passes through an interferometer, where the motion of an optical element, usually a mirror, optically modulates the infrared beam. The modulated IR beam then enters an absorption cell through a window (typically made of potassium bromide or zinc selenide) and interacts with the gases of interest. The physical length over which this interaction takes place is the “absorption path length.” In “multi-pass” (or “White”) absorption cells, mirrors within the cell direct the IR beam through the sample gas many times; in such cells, the absorption path length can be from 4 to 50 (or more) times the cell’s physical length. (A larger absorption path length generally leads to greater sensitivity.) The IR beam then exits the sample cell via a second window and is refocused onto an IR detector. Because this extractive technique requires the transport of gas samples through the FTIR absorption cell, the design and integrity of the sampling system is of great importance. It is also important that the sampling system allow the operator to perform all the necessary calibration and sampling procedures without compromising the speed and flexibility of the analytical system.

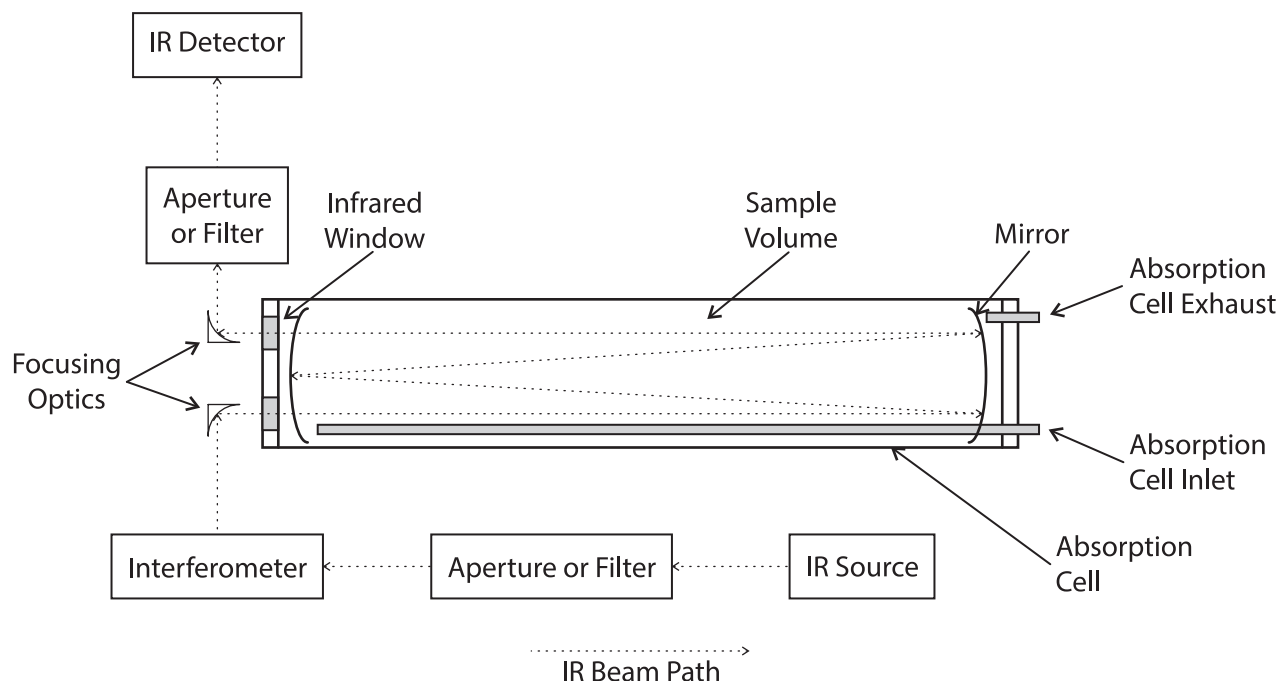

Figure C1. FTIR spectrometer components and beam path.

Figure C2 illustrates a sampling system configuration that meets these requirements, though other configurations are possible. A computer controls the actions of the interferometer and records the voltage output of the IR detector throughout the motion of the interferometer’s optical element. Ideally, the detector voltage is proportional to the total power in the IR beam. The computer must accurately record the detector voltage as a function of the position of the moving element in the interferometer, so a secondary, laser-based optical system is usually used to measure the moving element’s position very precisely. In most circumstances, the motion of the mirror or other optical element is repeated many times and the resulting individual “scans” are “co-added” (averaged) to reduce the system’s RSA.

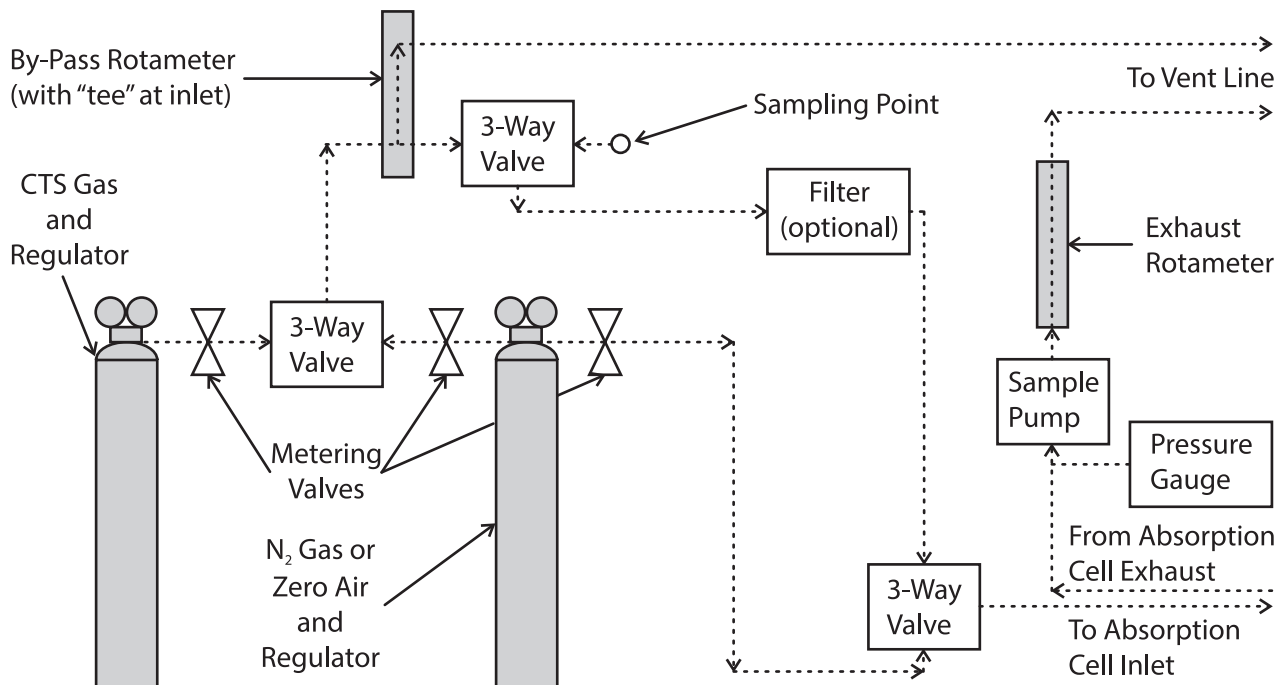

Figure C2. Sampling components and sample paths.

A plot of the resulting IR power-vs.-position signal, referred to as an interferogram, is shown in Figure C3. This interferogram is the co-added result of 64 scans with only nitrogen gas (and some low level of water vapor) present in the absorption cell. Nitrogen is one of the few compounds that does not interact with infrared radiation, so this interferogram very closely represents the fundamental FTIR system response in the absence of a sample. Note that the signal is relatively large near the beginning of the interferogram, where the “zero phase difference (ZPD) burst” is located. The ZPD is often used to rapidly obtain an estimate of the IR signal strength during alignment of the optical system.

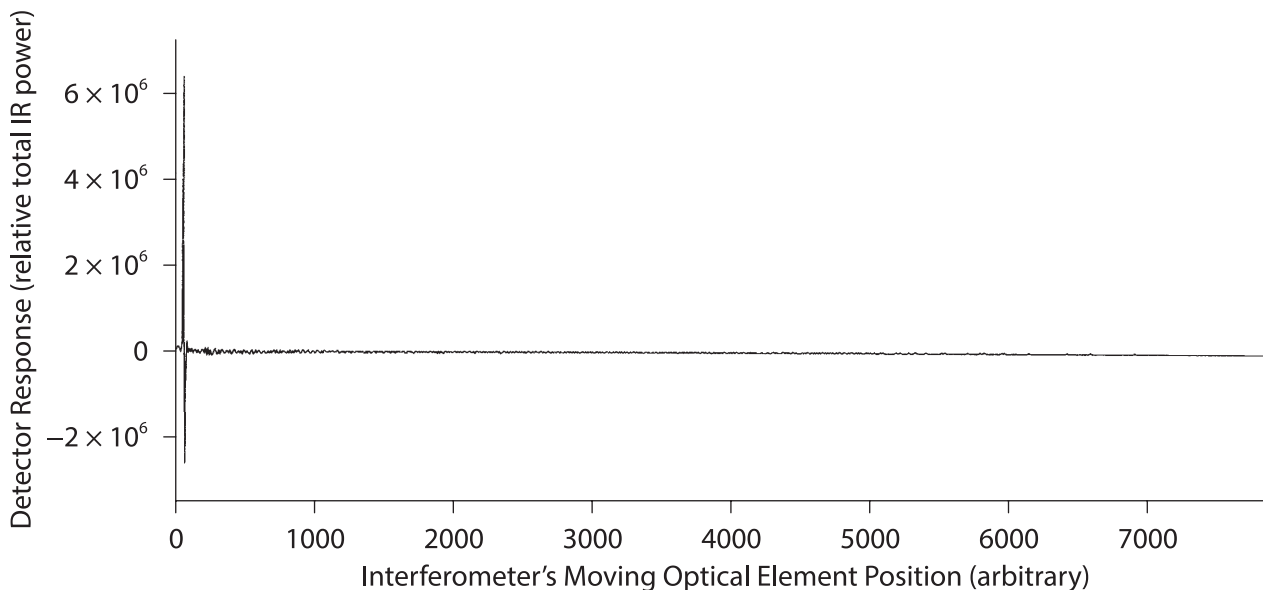

Figure C3. Mid-infrared interferogram.

C2. The FFT

Every data point in the interferogram contains intensity information about every infrared wavelength transmitted from the source to the detector. It is possible to recover the intensity information as a function of wavelength through application of an FFT, from which the FTIR technique's name is derived. This digital transformation of the interferogram can be thought of as the mathematical inverse of the optical modulation applied to the infrared beam as it passes through the interferometer. Its function is similar to that of the human brain and ear, which provide intensity information (loudness) versus wavelength (pitch) for complex signals (sound waves) incident on the eardrum. (Note that, as for an interferogram, each point in a complex sound wave contains intensity information about every pitch contained in the wave. Yet the ear and brain allow a symphony audience to immediately perceive, for instance, that the piccolo is playing very loudly while the tuba is playing very quietly.) Reference 12 (chapter 3) provides a complete mathematical description of the FFT.

C3. Instrument Resolution, Apodization Function, and MIL

Most software packages supplied with FTIR systems provide several options associated with the collection of data and application of the FFT. These typically include - at least - the nominal "instrument resolution" (specified in cm^{-1}) and the "apodization function" (e.g., "boxcar" and "triangular"). These parameters are very important in quantitative spectroscopy and are addressed in turn below.

The instrument resolution is the most fundamental and important instrument parameter. It specifies the nominal minimum FWHM, in cm^{-1} , of any spectral "peak" (or "line") in the final instrument output. Every FTIR instrument has a minimum FWHM determined by the maximum distance traversed by the interferometer's moving element during a single scan. (For the basic Michelson interferometer, the FWHM in cm^{-1} is equal to $(2d)^{-1}$, where d is the distance in cm traversed by a moving mirror during a scan.) Clearly, instruments with low FWHM provide more spectral information than instruments with higher FWHM capability. However, this additional information comes at high costs associated with the design, construction, size, mechanical stability, portability, speed, and RSA of the instruments.

It is important to recognize the two uses of the word "resolution" in the nomenclature used to describe FTIR spectrometers: Instruments of high resolving power, or "high resolution," provide spectral features of *low* FWHM; when the nominal resolution is specified in units of cm^{-1} , a *lower* cm^{-1} specification corresponds to *higher* resolving power, or "higher resolution". Most commercially available FTIR spectrometers suitable for field use provide FWHM values greater than or equal to 0.5 cm^{-1} , that is, they are systems whose nominal spectral resolution is specified as a number higher than 0.5 cm^{-1} . Most of the instruments capable of higher resolution (lower FWHM) are suitable for use only in very stable laboratory environments.

Standard FTIR operating software always provides options for recording spectra with FWHM values higher than the instrument's actual lower FWHM limit. These options simply move the mirror (or other optical element) through only some fraction of its maximum possible travel. Operating the instrument in this manner results in larger FWHM values ("lower" resolution, and shorter interferograms) than the instrument is mechanically capable of providing. Spectra of lower resolution (higher FWHM) provide less information, but can be generated more quickly and, in most cases, with lower RSA than spectra of higher resolution.

The instrument operator can also choose the apodization function to be used in the generation of FTIR spectra. Apodization is a mathematical alteration of the interferogram that can be performed before application of the FFT. Several standard alteration functions have been devised and each affects the final absorption spectrum of the sample gas in a different way. As with the selection of instrument resolution, each choice has its advantages and drawbacks. The simplest choice, known as the "boxcar apodization" function, results in the lowest FWHM but also in relatively low signal to noise (S/N) ratio. (Spectra generated with the boxcar function are often referred to as "unapodized" spectra.) Other choices (triangular, Norton-Bier, and several other apodization functions) provide higher S/N ratio

at the cost of higher FWHM values and other trade-offs in quantitative spectroscopy. Reference 12 provides a more thorough description of the characteristics of various apodization functions.

For a given instrument configuration — which includes the nominal spectral resolution and the choice of apodization function — every FTIR system is capable of generating absorption bands with an MIL. Unlike the actual spectral resolution (which has several accepted physical definitions — see reference 12, chapter 1, section IV) and nominal spectral resolution parameters, the MIL is a parameter that is readily measured to the accuracy required for practical applications of FTIR spectrometry. It can be measured using the water absorption bands present in low-pressure workspace air samples (see APPENDIX B, section B3).

C4. Single-Beam Spectra

The mathematical result of the FFT (applied to an apodized IR interferogram) is called a single-beam spectrum. Single-beam spectra represent the infrared power transmitted through the FTIR spectrometer as a function of the infrared “wavenumber” w , which is usually expressed in the units of reciprocal centimeters (cm^{-1}). The wavenumber is actually a measure of the frequency, rather than the wavelength, of the infrared radiation. In a vacuum, the wavelength and frequency are related through the equation $\nu = c / \lambda$, where λ is the wavelength (cm), ν is the frequency (s^{-1} , or Hz), and c (cm/s) is the speed of light, equal to $2.99792954 \times 10^{10}$ in a vacuum. In these units, the wavenumber in cm^{-1} is given by the equation $w = 1/\lambda = \nu / c$. Figure C4 presents the single-beam spectra for two samples consisting mainly of nitrogen gas ($\geq 99\%$) but with different concentrations ($\leq 1\%$) of water vapor. The vertical scales of the two spectra are nearly identical, but they have been offset for clarity. The detected infrared power in certain wavenumber regions is clearly lower in the high moisture sample, indicating both the qualitative nature and strength of water’s absorption of infrared radiation.

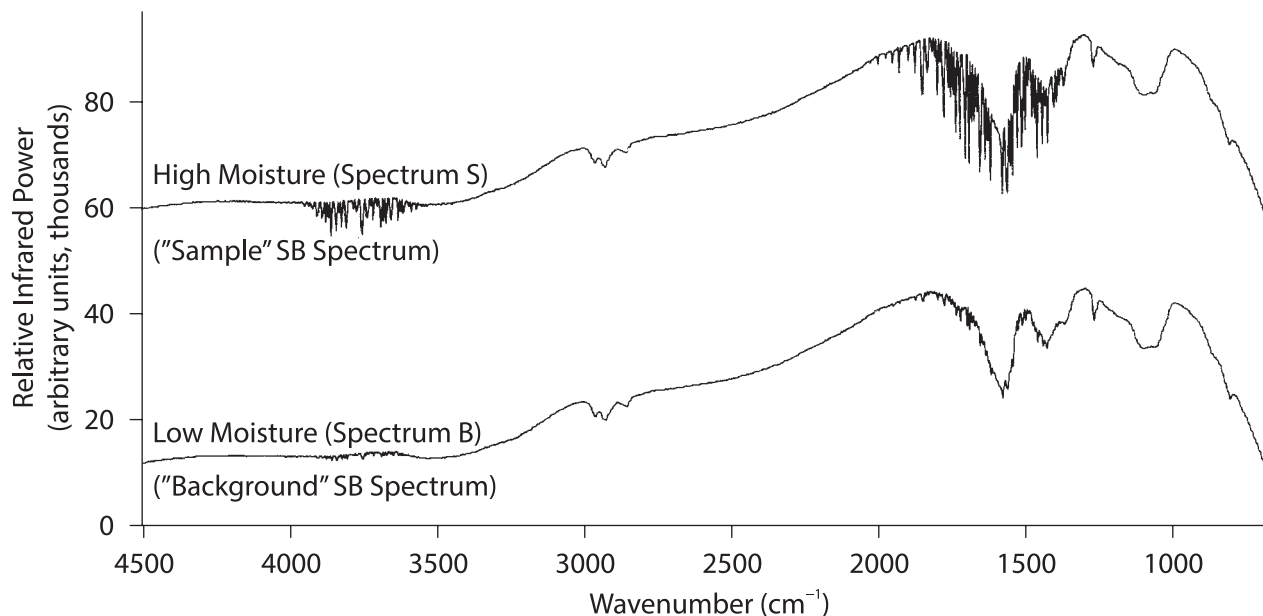

Figure C4. Single-beam spectra of nitrogen at different moisture levels.

C5. Double-Beam Spectra — Transmittance and Absorbance

Combinations of pairs of single-beam, such as the pair of spectra S and B shown in Figure C4, are referred to as double-beam spectra; they provide the quantitative basis for FTIR spectroscopy. One type of double-beam spectrum is the transmittance. The percent transmittance of a sample gas possessing the single-beam spectrum S — with respect to the background single-beam spectrum B — is defined as $T = 100 \times I_S / I_B$ (%), where I_S and I_B are the respective transmitted intensities; a transmittance value is

defined for each wavenumber value of the two spectra. If the background spectrum B closely represents the response of the FTIR system to a transparent sample, then the percent transmittance closely approximates the percentage of the infrared radiation transmitted by the sample (represented by the spectrum S). Because water is the only absorbing compound present in the single-beam spectrum B, the spectrum transmittance (shown in Figure C5) closely approximates the percent transmittance spectrum of water.

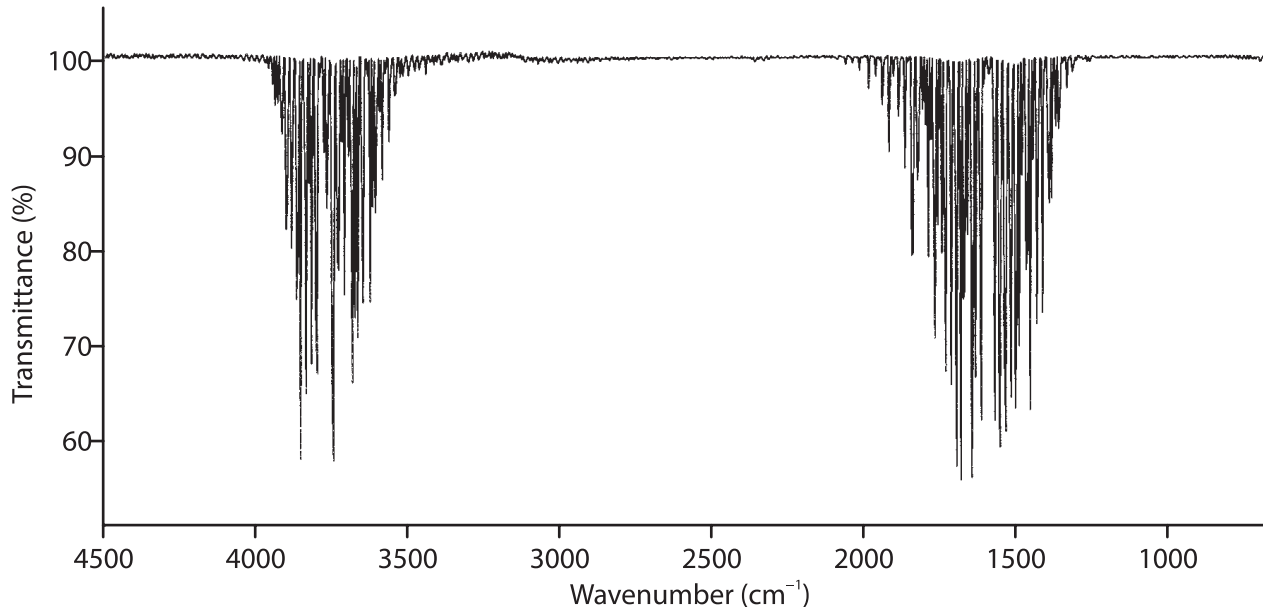

Figure C5. Double-beam transmittance spectrum of water.

The same pair of spectra define the (double-beam) absorbance A of the sample through the equation $A = -\log(I_s / I_b)$. The absorbance spectrum of water, as approximated by the two single-beam spectra S and B, is shown in Figure C6. The absorbance is the desired quantity because it appears in the general linear absorption model known as Beer's law (see below).

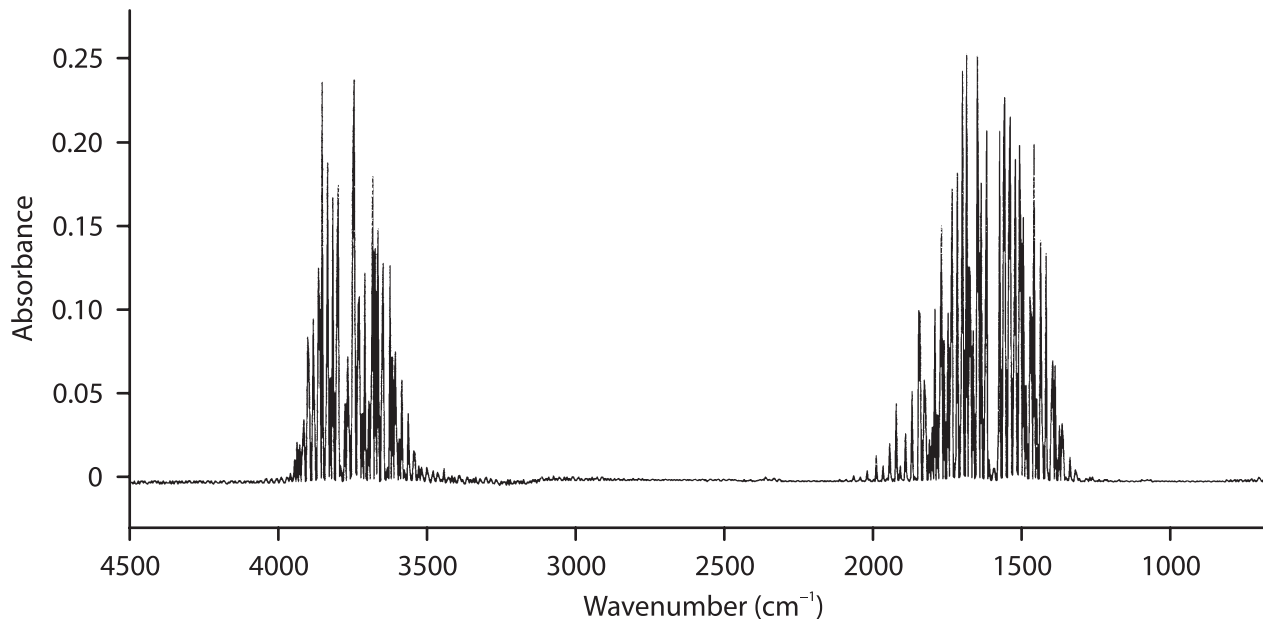

Figure C6. Double-beam absorbance spectrum of water.

C6. Beer's Law

The absorbance spectrum of a sample gas is determined from single-beam spectra of an infrared-transparent gas (the background spectrum) and the sample gas (see section C5). The fundamental relationship connecting the absorbance spectrum of a sample gas to the concentrations of the compounds comprising the sample is referred to as Beer's law. This relationship can be written as

$$A_i = \sum_{j=1}^{j=M} L_s a_{ij} C_j, \quad (\text{Equation C1})$$

where: i = an index labeling the frequencies of the observed absorbance values in the sample's absorbance spectrum,

A_i = the observed absorbance of a sample at the i^{th} wavenumber,

L_s = the sample absorption path length (m),

j = an index labeling the absorbing compounds comprising the sample,

a_{ij} = the absorptivity of the j^{th} compound at the i^{th} wavenumber (ppm/m),

C_j = the volumetric concentration of the j^{th} compound (ppm), and

M = the number of absorbing compounds in the sample.

The procedures described in this method are all related to the parameters that comprise Beer's law. The following list describes these procedures and relationships in a general context:

1. Record a reference absorbance spectrum for each interesting compound of a nitrogen-diluted sample of the pure compound, at a known concentration and path length, then divide the absorbance at each point in that spectrum by the CPP. This process yields the absorptivity spectrum (a_{ij}), or reference spectrum, for each compound.
2. Measure the absorbance A_i for the mixture of compounds (see steps 5 and 9 above).
3. Determine the path length L_s for the current measurement of A_i (see steps 5 and 7 above).
4. Select the analytical region — that is a set of frequencies, corresponding to the possible values of the index i — that are to be used to determine the concentration of each compound, and then mathematically invert Equation C1 to determine the desired concentrations C_j . (APPENDIX E addresses the topic of spectral analysis in detail.)

NOTE: The true absorptivity for a single gaseous compound is a characteristic only of the compound's structure. However, details of the FTIR system performance and operation affect the observed absorptivity and its accuracy. Similarly, FTIR measurements provide only an approximation of the true absorbance spectrum of a mixture of gaseous compounds, though it is, under many circumstances, a sufficiently accurate approximation. It is the responsibility of the analyst to verify and ensure that the reference and sample spectra provide a sufficiently accurate quantitative analysis according to Beer's law. The following sections of this appendix describe the mathematics of such an analysis. APPENDIX D addresses the topics of developing and using reference spectral libraries. APPENDIX E provides an illustrative example of the design and evaluation of the quantitative analytical process.

C7. Determining Concentrations with LSF Algorithms

When a sample gas contains only one absorbing compound, Equation C1 simplifies to

$$A_i = L_s a_{ij} C_j. \quad (\text{Equation C2})$$

This means that in any analytical region where only one gas absorbs, any one (of the usually many) absorbance spectrum values A_i can be used to yield the concentration C_j .

The absorbance area A_s for a single-component spectrum in an analytical region (from $i = p$ to $i = q$) can be written as

$$A_s = \sum_{i=p}^{i=q} A_i = \sum_{i=p}^{i=q} L_s a_{ij} C_j = L_s C_j \sum_{i=p}^{i=q} a_{ij} = L_s C_j A_R, \quad (\text{Equation C3})$$

where A_r is the area in the reference spectrum for that compound in the same analytical region. (This is the basis of the absorption path length L_s calculation described in step 7 and APPENDIX B, section B1.) Because calculation of the absorbance area involves many points in the sample spectrum, Equation C3 leads to much more accurate results than the single-point calculation represented by Equation C2.

However, when many absorbing compounds are present in a sample, the absorption patterns of the various compounds often overlap. In this case, there is usually not an isolated analytical region for each compound in which only that compound absorbs infrared radiation; no single absorbance point and no simple absorbance area is suitable for determining any of the component concentrations. In this case, the simplest method for determining concentrations is to use an LSF algorithm.

LSF algorithms use the fact that there is some set of estimated concentrations D_j that minimizes the “squared error” in Beer’s law for any given analytical region, for any set of compounds. The only requirement on the chosen analytical region is that it must contain a sufficient number of data points; since each FTIR spectrum contains many thousands of absorbance values, this requirement is nearly always fulfilled.

If we use the estimated concentrations D_j (rather than the true concentrations C_j) in Beer’s law, they will lead to some estimated error e_i at each value of i (that is, at each point in the analytical region we choose). Equation C1 becomes:

$$A_i = e_i + \sum_{j=1}^{j=M} L_s a_{ij} D_j \quad (\text{Equation C4})$$

The estimated squared error E^2 (or “variance”) in Beer’s law using the estimated concentrations is:

$$E^2 = \sum_{i=1}^{i=N} e_i^2 = \sum_{i=1}^{i=N} \left[\sum_{j=1}^{j=M} L_s a_{ij} D_j - A_i \right]^2 \quad (\text{Equation C5})$$

where N represents the number of absorbance values in the analytical region. Reference 13 demonstrates that 1) for $N > M$ there is a unique set of estimated concentrations D_j that minimizes the estimated squared error; 2) this set of values is calculable from the known quantities in Equations C1, C2, C3, C4, and C5; and 3) estimates σ_j of the uncertainties in the quantities D_j are also calculable from the same quantities. The value $3\sigma_j$ is generally accepted as a conservative estimate of the statistical uncertainty in the related estimated LSF concentration (see reference 4).

The estimated LSF error at each point in the analytical region,

$$e_i = A_i - \sum_{j=1}^{j=M} L_s a_{ij} D_j \quad (\text{Equation C6})$$

is usually stored following the analysis as a “residual spectrum,” which can provide an estimate of the LODs for other compounds. In addition, the residual spectrum and the concentration uncertainties can allow the analyst to detect and identify compounds that are actually present in the sample gas but which were not included in the mathematical analysis. APPENDIX E provides an example illustrative of these procedures.

The above description illustrates a simple and easily interpreted LSF analysis. More sophisticated LSF analytical techniques, possibly more accurate for particular types of samples, are described in the literature (see, for example, reference 14 and references therein).

C8. Calibration Transfer and Reference Libraries

Equations C1, C2, C3, C4, C5, and C6 demonstrate the importance of quantities L_s (the absorption path length) and a_{ij} (the absorptivity) in FTIR spectrometry. Accurate determinations of these quantities allow the use of reference libraries for quantitative analyses without the necessity of compound-specific field calibrations. The system tests described in the procedures and in APPENDIX B are intended to ensure suitability of the system configuration for such calibration transfers, as are the requirements

of obtaining CTS spectra in field. APPENDIX D describes procedures for recording and processing reference library spectra.

C9. Corrections to Deviations from Beer's Law Exhibited by FTIR Spectra

Beer's law is based on fundamental, well-established physical principles. It holds absolutely for gas samples that are at thermal equilibrium and dominated by induced (rather than spontaneous) emission and absorption processes. (See Note below.) However, *this is not to say that the absorbance, as measured by an FTIR spectrometer, follows Beer's law under all conditions.* Deviations from Beer's law in FTIR spectra are often observed; however, they indicate inaccuracies in the FTIR spectra, not "violations" of Beer's law. For example, deviation from Beer's law is commonly exhibited by sets of single-component reference spectra recorded over a range of absorbance levels. At large enough values of the absorbance, the points A_i of stronger absorption bands of such spectra no longer increase linearly with the CPP $L_R \cdot C_j$; this is why Table 2 specifies a maximum ppm · m value for the listed reference spectra. If the assumption of detector linearity does not hold (see APPENDIX B), similar effects are often present in reference and sample spectra; this is the basis for the system test described in APPENDIX B, section B6.

Mathematical correction of the concentration estimates D_j derived from Beer's law can often reduce the error in sample analyses when either type of non-linear effect occurs. Figure C7 provides an example of such a correction. The actual and calculated ppm · m values for a set of reference spectra are plotted against each other, a "piece-wise linear" approximation to the pattern is shown by the solid line, and the dashed line indicates the ideal linear behavior based on the spectrum of lowest absorbance. At any ppm · m value indicated in a Beer's law sample analysis (that is, for any y-axis value up to approximately 900 ppm · m in the example), reasonably accurate values are available from the corresponding x-axis position of the solid line. If the analyst employs such corrections, he or she should also calculate the residual (Equation C6) using the reference spectrum that minimizes the squared error (Equation C5). FTIR analysts and manufacturers have devised other correction procedures to improve the sample analysis accuracy in such circumstances, and these are included in some commercially available software packages.

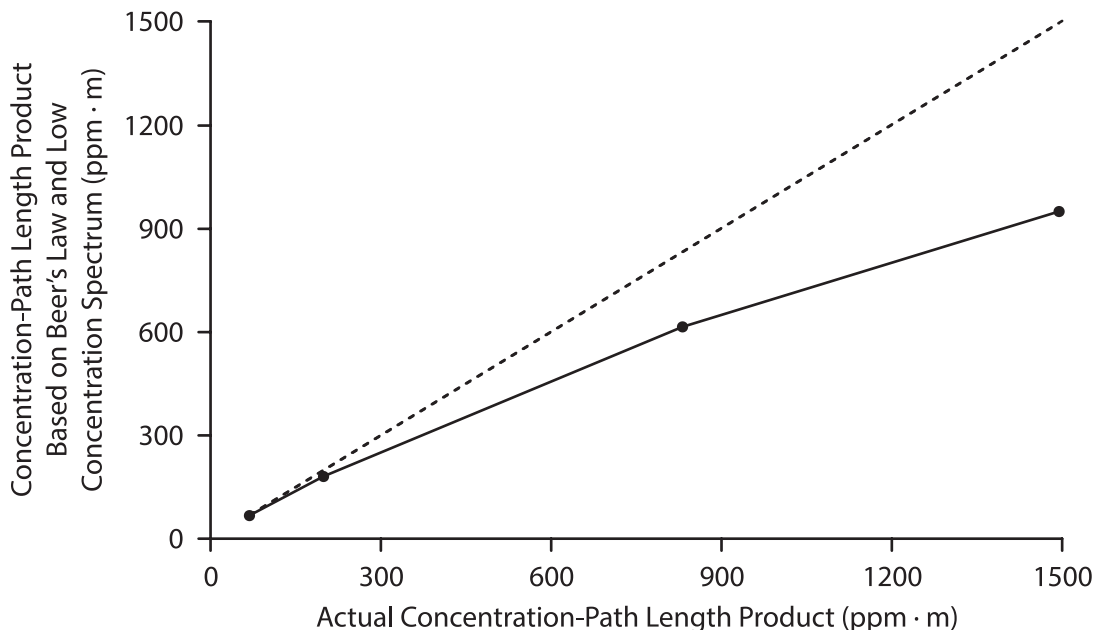

Figure C7. Example absorbance non-linearity for a set of single-component reference spectra.

NOTE: Intense infrared radiation, such as that produced by some lasers, can induce non-equilibrium populations of a molecule's rotation-vibration energy states. However, the thermal infrared sources

used in commercially available FTIR spectrometers are much weaker than such lasers. In gases at atmospheric pressure, the commercially available thermal sources induce transition rates between quantum energy states that are small, compared to those of the competing collisional relaxation processes, and cannot induce non-equilibrium energy state populations. In addition, the induced transition rates related to absorption and emission at mid-infrared frequencies are much larger than the corresponding spontaneous (natural) emission rate. As a result, all *accurate* FTIR measurements at mid-infrared frequencies obey Beer's law to within the uncertainty related *only* to the S/N ratio of the measured spectra.

APPENDIX D. PURPOSES, PREPARATION, AND USE OF REFERENCE SPECTRAL LIBRARIES

D1. Purposes of Reference Spectral Libraries

FTIR analyses rely on the availability of libraries of spectral information on the compounds of interest. For gases, the measured absorbance of a single component is often completely independent of the concentrations of other gases comprising the sample, and single-component reference spectra are usually employed. (For condensed phases, there are often strong interactions between components, and reference spectral libraries of mixtures are usually required.) Reference libraries may be used for quantitative measurements of analyte concentrations, for the mathematical removal of spectral features of interferants in a mixture, or simply for the identification of compounds in a mixture. Clearly, the required level of quantitative accuracy of the library is different for these three tasks; the highest quality is required for analyte concentration determinations, while no quantitative information is required for interferant removal and compound identification.

A useful characteristic of extractive FTIR spectrometry is that it provides accurate field measurements for many compounds, but requires field calibration procedures involving only two compounds. The water vapor available in every ambient air sample serves to calibrate the wavenumber (x) axes of FTIR absorbance spectra; a single CTS gas serves to calibrate their concentration-related (y) axes. When these two field calibrations are combined with an appropriate reference spectral library describing additional compounds, the measurement capability of the technique is practically limited only by the quality and scope of the reference library. If the reference library is carefully prepared and properly employed, this characteristic can lead to greatly lowered field test costs, since the calibration materials need be handled only once and only in the laboratory.

D2. Reference and Field FTIR System Configurations

In the ideal case, the reference library can be prepared on the field instrument, but this is often impractical; the reference library is usually prepared on specific laboratory systems and employed in measurements made with many field systems. Reference libraries recorded on a specific instrument provide accurate quantitative analyses for spectra recorded on other instruments only when the configurations of the various systems are compatible. Table D1 lists compatibility considerations for the reference system configuration parameters.

D3. Wavenumber Standard Spectra

Except in extremely dry conditions, the IR absorption by water vapor in workspace air is detectable at even very short absorption path lengths. The wavenumber positions of water vapor indicated by the reference system allow the analyst to confirm the wavenumber accuracy of sample spectra recorded on a different FTIR system in the field. Reference spectra used for this purpose are referred to here as the wavenumber standard spectra.

Every spectrum in a reference library should be associated with a wavenumber standard spectrum collected under the identical system configuration; even when the reference FTIR system is in a stable environment, it is recommended that a wavenumber standard spectrum be recorded daily with the system.

Before recording reference spectra, the analyst should check the most recent wavenumber standard spectrum against previous wavenumber standard spectra in the library; see APPENDIX B, section B4 for recommended calculations. If the wavenumber reproducibility of the system is poor, the resulting reference spectra may not be suitable for quantitative use on other field systems.

Table D1. Reference and field system configuration parameters

| Parameter | Requirements for Reference and Field Systems |
|---------------------------------|--|
| Minimum instrumental linewidth | Reference MIL must be less than or equal to field MIL. See APPENDIX B, section B3 for MIL measurement technique. |
| Gas temperature | Reference temperature within 20 °C of field temperature. Density corrections based on ideal gas law are accurate over only this narrow temperature range and their exact accuracy is compound-dependent. |
| Gas pressure | Reference pressure within 20% of absolute field pressure. Pressure corrections based on ideal gas law are accurate over at least this range, but their accuracy is compound-dependent. Atmospheric pressure is recommended for all measurements. |
| Apodization function | Reference and field apodization functions must be the same. A single set of reference interferograms (background and sample) can be used to generate a multiple sets of absorbance spectra using different apodization functions. |
| Zero filling factor | Reference and field zero filling factors must be the same. A single set of reference interferograms (background and sample) recorded with no zero filling can be used to generate a multiple set of absorbance spectra using different zero filling factors. |
| Wavenumber accuracy | Characterized by the position of water absorption bands in a wavenumber standard spectrum (see below); if additions to an existing library are being made, care must be taken to match the x-axes of all spectra as closely as possible. |
| Integration time | Reference integration times (for both background and sample interferograms) should be greater than or equal to expected field integration times. For reference libraries, the longest practical integration time is recommended. |
| Detector type and serial number | If an MCT or other potentially non-linear detector is employed in the reference system, IR attenuation may be required to ensure linearity; see APPENDIX B, section B6; because each detector may exhibit linearity to a specific degree, the serial number of the detector should be included in any specification of the system configuration. |

D4. Obtaining and Preparing Standard Reference Gases

The accuracy of any FTIR quantitative analysis is limited by the accuracy of the concentrations of the gas standards used in preparing the reference library. It is therefore important to use gas standards of the highest available quality. NIST-traceable gravimetric standards are available from many commercial sources and are quoted to 2% accuracy in many circumstances; EPA has also published guidance on the preparation of "EPA Protocol Gases" (see reference 15), though these are available for only a limited number of compounds. Users should obtain documentation from the gas vendors regarding the analytical techniques applied and the stability limits (concentration and time) of the compounds in the cylinders. When possible, an alternative analytical method should be used to verify the quoted cylinder concentrations, especially for compounds that are reactive, corrosive, or have relatively high boiling points.

If cylinder standards are not available for a compound, the analyst may prepare reference gases based on gravimetric, barometric, or dynamic methods. In any case, the related mass, pressure, and flow measurements should be made with NIST-traceable equipment whenever possible. In general, methods that provide a stream of standard gas (dynamic methods) provide more reliable results than static methods, since the concentrations of static gases are more prone to change when reactions between the standards and the sampling system or absorption cell surface can occur.

D5. Determining the Reference Absorption Path Length

The accuracy of any FTIR quantitative analysis is limited by the accuracy to which the path length of the absorption cell used in preparing the reference library is known. For single-pass absorption cells through which a collimated IR beam is passed, the path length can be physically measured to high accuracy. For multi-pass cells, the nominal path length can be estimated from the base path length and the number of passes. However, because focused beams and curved mirrors are required in multi-pass cells, the path length estimated in this fashion can differ significantly from the actual path length. Because of this, combinations of physical and spectroscopic measurements with multiple CTS gas standards (see below) and single-pass absorption cells should be employed to determine the actual path length of multi-pass absorption cells.

D6. Recording CTS Spectra

The CTS gas is used to characterize the absorption path lengths of the reference and field FTIR systems. Ethylene in nitrogen, at concentrations leading to between 100 ppm · m and 300 ppm · m CPP values for the systems, is recommended; for ethylene, spectra with ppm · m values greater than 300 begin to exhibit non-linear absorbance and must be carefully analyzed (see sections D8 and D9 below). Standards of this gas with 2% accuracy are readily available and both the EPA and NIST libraries contain ethylene spectra that can be used to link those libraries to measurements performed with field instruments. However, almost any other stable compound with appropriate IR absorption characteristics can be used in developing an independent reference library and for accurate field measurements.

In the field, CTS spectra must be recorded both before and after sample spectra are acquired using the same system configuration employed in recording the sample spectra (see steps 7 and 11 above).

When developing reference spectra, the analyst must record CTS spectra at least daily; each reference spectrum should be associated with at least one CTS spectrum. The analyst must use the same system configuration employed in recording the reference spectra, with one exception: The integration time used for the CTS spectra may be less than that used for the reference spectra, if the quality of the resulting CTS spectra is still sufficient for an accurate determination of the absorption path length. It is highly recommended that the analyst store all the interferograms from which the CTS absorbance spectra are generated, including all background interferograms. The interferometric data provide the most direct method of verifying the FFT calculations and/or adding reference absorbance spectra for other apodization function choices.

D7. Recording Reference Spectra

Before recording reference spectra, verify that the requirements specified for system checks, system configuration parameters, gas standards, absorbance path length determinations, and CTS spectra described in the pertinent sections of this appendix and Appendix B have been met. Additional checks of the sample gas pressure and temperature should also be made periodically as the spectra are recorded.

It is highly recommended that the analyst store all the interferograms from which the reference absorbance spectra are generated, including all background interferograms. The interferometric data provide the most direct method of verifying the FFT calculations and/or adding reference absorbance spectra for other apodization function choices.

Beer's law (Equation C1) describes the fundamental linearity of the infrared absorbance versus concentration. However, the resolution (and other) limitations of instruments typically used to generate field FTIR spectra often lead to non-linear behavior for many compounds, even at low absorbance levels. The expected accuracy of FTIR-based measurements results for a particular compound can be

achieved only when 1) the reference absorbance is characterized at a sufficient number of CPP values, up to some maximum value and 2) the sample absorbance associated with any compound represents a value lower than that of the maximum CCP value represented in the reference library for that compound.

For each analyte, the analyst should record two reference spectra at each of two concentration values (that is, at least four spectra) at a single absorption path length; the two concentrations should be separated by no more than a factor of 10, and a maximum factor of 5 is recommended. After recording these spectra, the analyst must 1) permanently record the system parameters and the maximum measured CPP and 2) characterize the linearity of the absorbance across the measured CPP range (see section D8). It may be necessary to record additional reference spectra for the analyte if either the absorbance linearity or maximum CPP value proves unsuitable for later field measurements.

D8. Linearity Checks

The performance of linearity checks on a set of reference spectra is an important aspect of FTIR spectrometry and is best illustrated by a practical example. The following example is based on a series of reference measurements performed on the compound tetrafluoroethylene, hereafter referred to as TFE.

Five absorbance spectra for TFE are shown in Figure D1. These spectra were recorded over the entire mid-IR wavenumber range, but only that portion of the spectra showing the most intense TFE absorption bands is included in the figure. Each of the spectra was calculated by mathematically averaging a number of TFE absorbance spectra recorded with the system configuration parameters given in Table D2, and a linear baseline correction was applied to each of these spectra over the range illustrated in Figure D1.

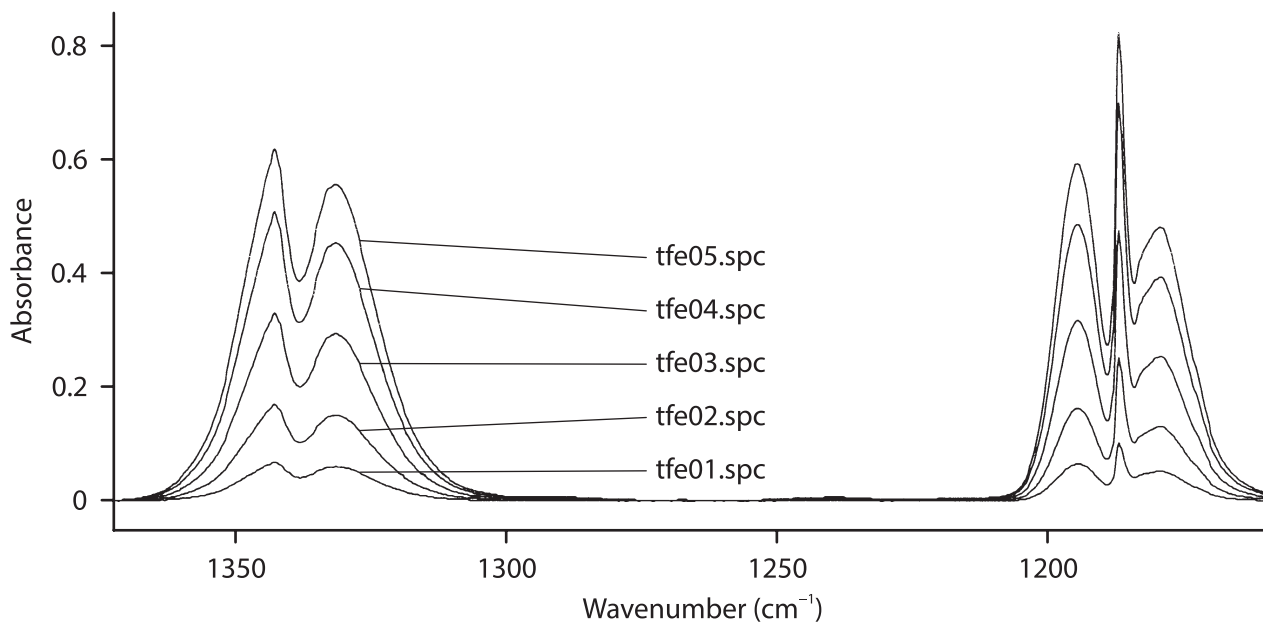

Figure D1. Reference absorbance spectra of TFE (x-axis truncated).

Table D2. System configuration parameters for TFE reference spectra (see Figure D1)

| System Configuration Parameters | Values/Notes |
|---------------------------------|---------------------------------------|
| MIL (cm ⁻¹) | 0.5 |
| Integration time (s) | 1080 (120 s per spectrum × 9 spectra) |
| Absorption path length (m) | 10.23 |
| Gas temperature (°C) | 15 |
| Gas pressure (kPa) | 101.3 ± 1.3 (760 mmHg ± 10 mmHg) |
| Apodization function | Triangular |
| Zero filling factor | Zero |
| Detector type | MCT |
| Detector gain (hardware) | Jumpers B, C, and D |
| Detector gain (software) | 1 |
| Reference CTS spectra | j2kety.spc |
| Wavenumber standard spectrum | j2kety.spc |

The reference gas samples were generated by diluting with nitrogen the output of a single standard gas cylinder of TFE. The TFE concentration of the standard cylinder was determined (by the gas vendor) according to NIST-traceable gravimetric measurements and the flow rates of the cylinder gas were measured with a NIST-traceable volumetric device.

One technique to check for the linearity of this set is to form a normalized average of these five spectra and then use it in a linear analysis of the five original spectra. The normalization consists of dividing each spectrum by its CPP; these values, based on the CTS-derived path length of 10.23 m, are given with the actual gas concentrations and new spectral filenames in Table D3. Figure D2 illustrates the normalized spectra, all of which represent spectra of CPP values 1.00 ppm · m. These spectra are nearly equal to one another, as predicted by Beer's law. Only the spectrum tfe01n.spc, based on the original 25.53 ppm spectrum, is easily discernible from the other spectra in the figure.

Table D3. Normalization factors for TFE spectra

| Original Spectrum | Concentration (ppm) | Concentration-Path Length Product (ppm · m) | Normalized Spectrum |
|-------------------|---------------------|---|---------------------|
| tfe01.spc | 2.50 | 25.5 | tfe01n.spc |
| tfe02.spc | 6.63 | 67.8 | tfe02n.spc |
| tfe03.spc | 13.3 | 133 | tfe03n.spc |
| tfe04.spc | 20.4 | 208 | tfe04n.spc |
| tfe05.spc | 25.1 | 257 | tfe05n.spc |

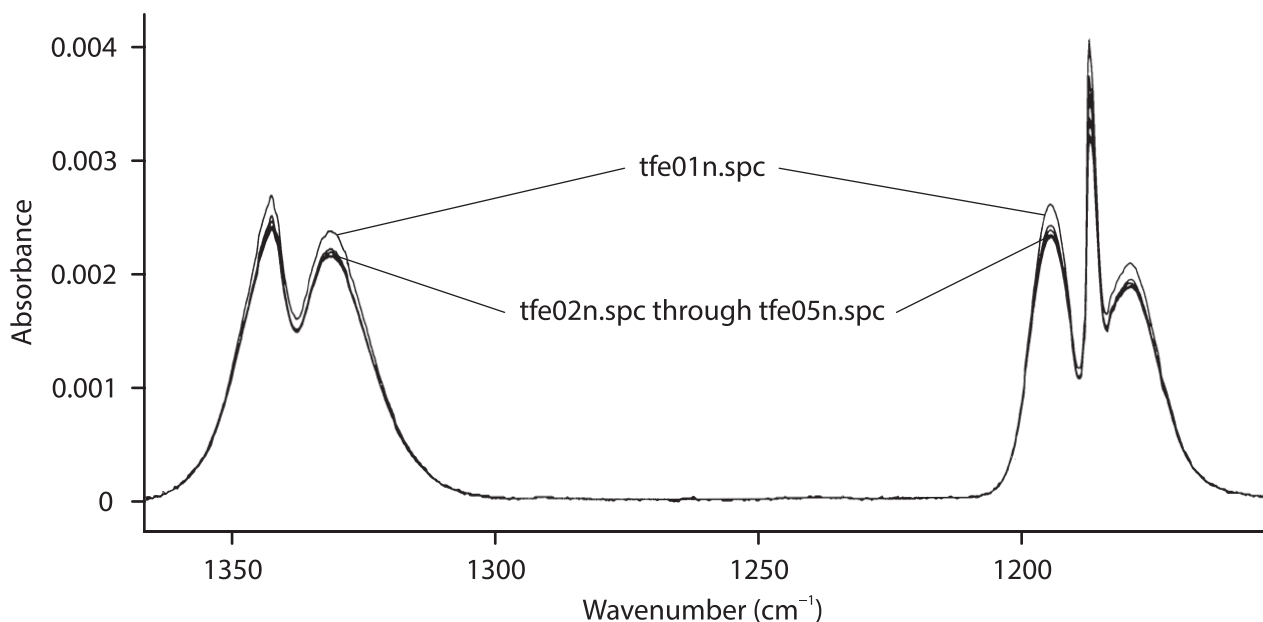

Figure D2. Normalized reference absorbance spectra for TFE.

Table D4 shows the results of a linear least-squares analysis using the *average* normalized spectrum as a single reference spectrum (with CPP 1.00 ppm · m) over the analytical range 1050 cm⁻¹ to 1400 cm⁻¹. The bias in the linear method is clearly evident in the fourth column of the table, which indicates that the analysis yields concentrations that are slightly too high at the lowest concentration and slightly too low at the highest concentration. The average of the last column in the table, which represents the absolute percent difference between the actual and calculated concentrations, the “fractional calibration uncertainty” (FCU; see reference 3), is 3.2%. This value represents the average error over the concentration range for these reference spectra to be expected from the linear analysis up to the maximum CPP value used in the analysis (257 ppm · m). If additional accuracy is required, non-linear analyses or corrections such as those discussed above (Appendix B, section B6) can be employed.

Table D4. Results of linear least squares analysis for TFE reference spectra

| TFE Reference Spectrum | Calculated Concentration (ppm) | Actual Concentration (ppm) | Actual – Calculated Concentration (ppm) | Absolute Percent Difference |
|------------------------|--------------------------------|----------------------------|---|-----------------------------|
| tfe01.spc | 2.69 | 2.50 | 0.19 | 7.7 |
| tfe02.spc | 6.64 | 6.63 | 0.01 | 0.2 |
| tfe03.spc | 12.8 | 13.0 | -0.2 | 1.4 |
| tfe04.spc | 19.8 | 20.4 | -0.6 | 2.9 |
| tfe05.spc | 24.2 | 25.1 | -0.9 | 3.7 |

D9. Calculating the LOD

The estimated LODs are the concentrations — for the given system configuration, reference spectra, and analytical region — at which each compound’s absorbance area is equal to the RSA. For a specified system configuration and analytical region, an estimate of the LOD (L_D) for a compound can be made

from the absorbance area of a reference spectrum in that region (A_R , cm^{-1}), the reference spectrum CPP (P_{CP} , $\text{ppm} \cdot \text{m}$), the sample absorption path length (L , m), and the RSA values (A_{RS} , cm^{-1}) as

$$L_D = \frac{P_{CP} \times A_{RS}}{L \times A_R}. \quad (\text{Equation D1})$$

A simple trapezoidal approximation of A_R over the analytical region of interest, including baseline corrections when necessary, is suitable for the LOD estimate. The RSA is formed from the product of the FTIR system's typical root-mean-square noise level in absorbance and the width of the analytical region in cm^{-1} (see APPENDIX B, section B2); the RSA estimate should reflect the error incurred in subtracting known spectral interferences. APPENDIX E, section E1 presents detailed examples of RSA and LOD calculations.

D10. Using Existing Reference Libraries

The analyst may use any of the publicly available reference libraries for quantitative analyses, but it is strongly recommended that quantitative results for analytes be based only on spectra from libraries that meet the requirements discussed in this appendix. If the reference library consists of spectra recorded at a spectral resolution different from that of the field system, the analyst must 1) deresolve the spectra mathematically to that of the field data and 2) ensure that the library data are suitably linear over the desired measurement range *at the spectral resolution of the field system*.

APPENDIX E. EXAMPLE CALCULATIONS

This appendix uses an analysis of TFE and 1,1-difluoroethylene (DFE) in workplace air to illustrate the calculations of RSA and LODs. The topics of designing, applying and verifying, and correcting a spectral analysis are also addressed below.

The FTIR system configuration assumed for this set of calculations is given below. These parameters are consistent with the LOD values presented in Table 2.

| System Configuration Parameters | Values/Notes |
|---------------------------------|---|
| MIL: | 0.5 cm^{-1} |
| Absorption path length: | 10 m |
| Apodization function: | Triangular |
| Gas temperature: | 293 K |
| Gas pressure: | 101.3 kPa |
| Zero filling factor: | None |
| Wavenumbers of water bands: | 1918 cm^{-1} and 2779 cm^{-1} |
| Reference library sources: | NIST, EPA |
| Integration time: | 70 s (64 scans) |
| Detector type: | MCT |
| Detector gain - hardware: | Gain jumpers A, D, and H |
| Detector gain - software: | 1.0 |

E1. RSA, Analysis Design, and LODs

The analysis is to be carried out in workspace air, so the only potential spectral interferences are due to water and carbon dioxide. Figure E1 illustrates example reference spectra of TFE, DFE, and water. (The water spectrum shown is typical of workspace air samples; carbon dioxide does not absorb in any of the spectrum. As a result, the limited spectral region shown in Figure E2 is actually of the greatest interest for an analysis of DFE and TFE in workspace air.

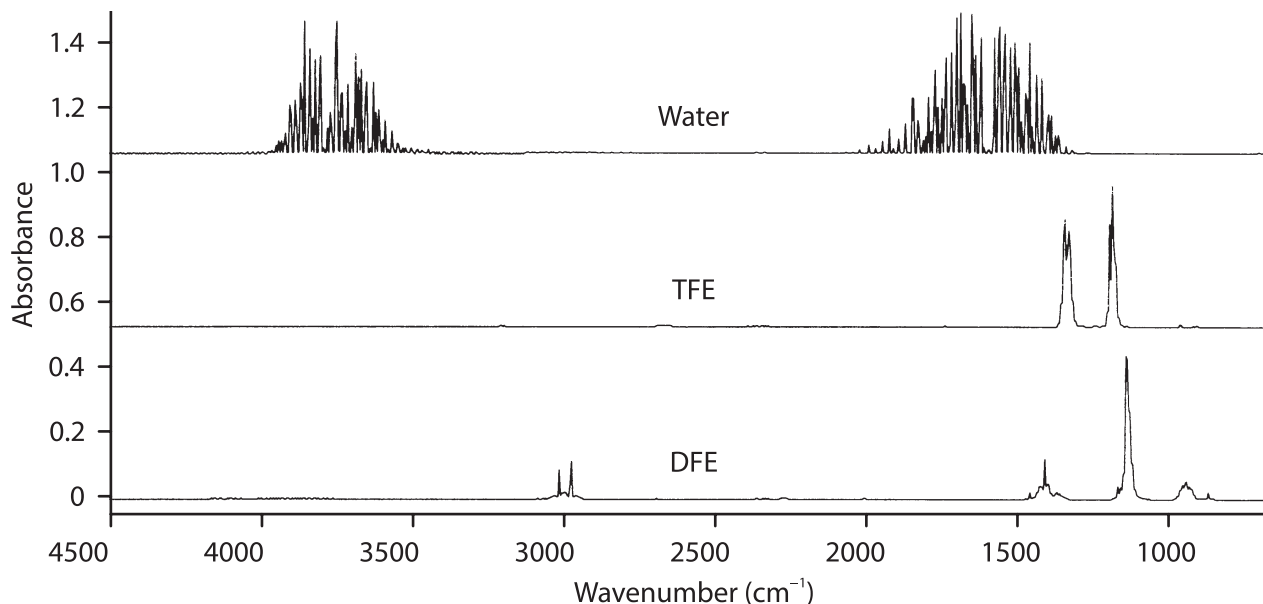

Figure E1. Absorbance reference spectra of TFE, DFE, and water.

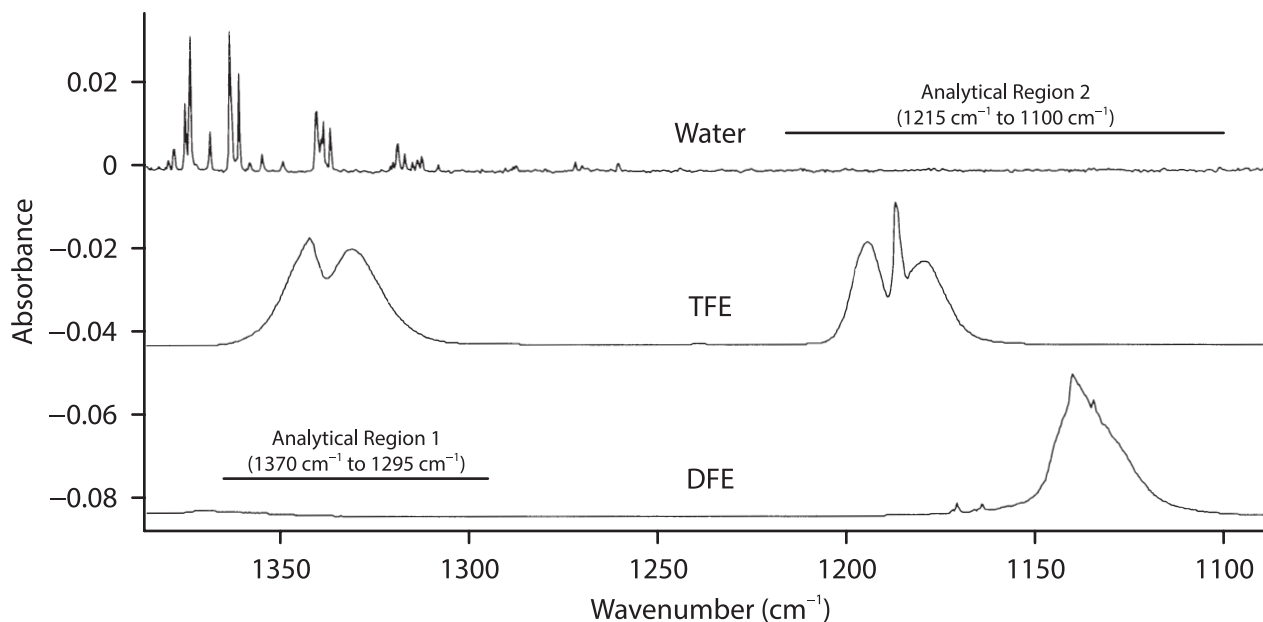

Figure E2. Possible analytical regions.

Shown in greater detail in Figure E2 are the three reference spectra and two possible analytical regions. Analytical region 1, from 1370 cm^{-1} to 1295 cm^{-1} , includes water bands that interfere with the TFE absorbance in the sample spectra. Analytical Region 2 (1215 cm^{-1} to 1100 cm^{-1}) may be the best choice for analyzing samples for both TFE and DFE (though the weaker features near 3000 cm^{-1} remain an option for DFE); it avoids the TFE interference with water, but necessarily includes some spectral overlap between the two analytes. Until the relative TFE, DFE, and water concentrations in the samples are known, it is unclear which of the two regions will provide better concentration estimates for TFE, so calculations for both regions are described below.

Estimation of the LODs for TFE and DFE requires a calculation of the RSA in the actual sample spectra over the selected analytical regions. The RSA represents an estimate, based on the assumed sample matrix and available reference spectra, of the residual absorbance (see Equation C6) that will be used to calculate the concentration uncertainties from the actual sample spectra.

The reader should note that the RSA and derived LOD are only estimates. If the actual sample matrix differs substantially from that of the sample matrix assumed in the performance of these estimates, the actual concentration uncertainties and LODs may differ substantially from the RSA and LOD values obtained in the calculations described below. For workplace air samples, water is the only interfering compound that is certain to appear in any of the analytical regions considered below. A realistic estimate of the RSA is therefore available by forming the mathematical difference of two water spectra — of substantially different water concentrations — recorded using the same FTIR system configuration. For each analyte, this estimate assumes that only water and that analyte will absorb substantially in the actual sample spectra. Later analyses based on the actual sample matrix could lead to either lower or higher concentration, uncertainty, and LOD estimates; examples of such analyses are detailed below.

Figures E3 and E4 illustrate two absorbance spectra recorded using the system configuration described above. They represent spectra of workspace air at approximately 20% and 40% relative humidity. The upper trace in each figure is slightly offset for clarity.

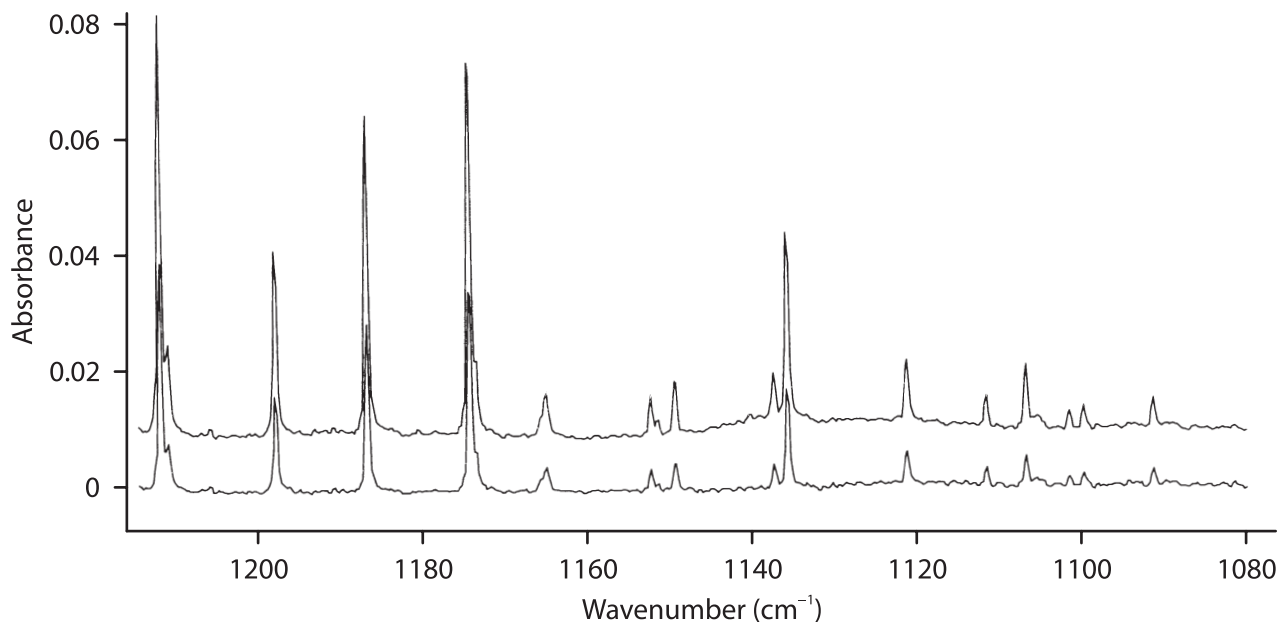

Figure E3. Water spectra 1215 cm^{-1} to 1080 cm^{-1} .

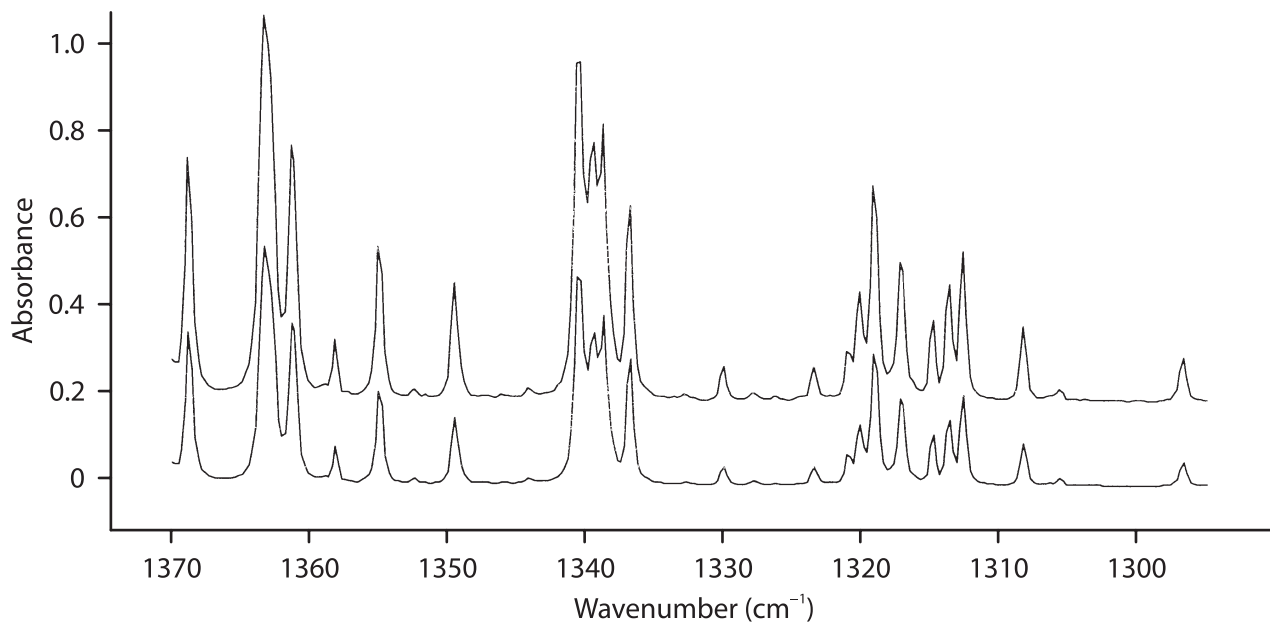

Figure E4. Water spectra 1370 cm^{-1} to 1295 cm^{-1} .

Figure E5 shows two residual spectra formed by subtracting scaled versions of the lower-absorbance spectrum from the higher-absorbance spectrum. The scaling factors were determined in independent LSF analyses over the two analytical regions. Linear baseline corrections (offset and slope) were also determined during the analyses, so the mean value of each residual spectrum is zero. (These calculations were performed by using the ANOVA data analysis tool in Microsoft Excel 97). The RSA values for the residual spectra are defined in Equation C2 and the related calculations are presented in Table E1. (The calculations also were performed in the program Excel by applying the function STDEV to the regression residuals.)

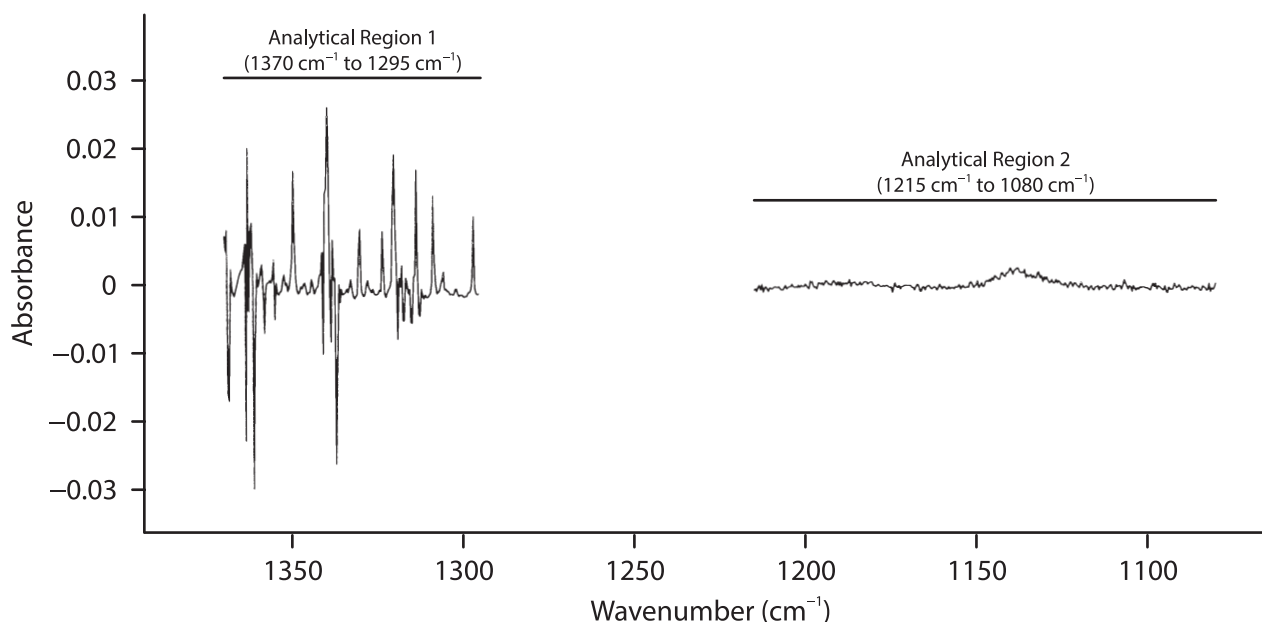

Figure E5. Water residual spectra.

Table E1. Results of RSA analysis from water reference spectra

| Analytical Region (cm ⁻¹) | Calculated Scaling Factor | Scaling Factor Uncertainty (1σ) | Residual RMS Standard Deviation (Absorbance) | RSA; Equation B2 (cm ⁻¹) |
|---------------------------------------|---------------------------|---------------------------------|--|--------------------------------------|
| 1370 to 1295 | 1.636 | 0.003 | 0.00575 | 0.431 |
| 1215 to 1080 | 1.870 | 0.008 | 0.00069 | 0.093 |

An estimate of the LODs (L_D , ppm) for the two compounds — for the specified system configuration — can be made from the absorbance areas of the reference spectra over these analytical ranges (A_R , cm⁻¹), the reference spectra CPPs (P_{CP} , ppm · m), the sample absorption path length L (m), and the RSA values (A_{RS} , cm⁻¹) derived above.

The absorbance areas were determined using a standard trapezoidal approximation without baseline correction. (For these spectra, baseline corrections lead to values that differ from those quoted by less than 3% and have been neglected below.) Figure E6 shows the spectral features of TFE and DFE used to calculate the A_R for the reference spectra tfeav05.spc (CPP = 256.7 ppm · m) and dfeav05.spc (CPP = 197.8 ppm · m).

The estimated LODs are the concentrations — for the given system configuration, reference spectra, and analytical region — at which each compound's absorbance area is equal to the RSA. Mathematically, the LOD estimates are given by

$$L_D = \frac{P_{CP} \times A_{RS}}{L \times A_R} \quad (\text{Equation E1})$$

Table E2 lists the pertinent quantities and resulting LODs for DFE and TFE in the two analytical regions considered. The results indicate that the analytical region from 1215 cm⁻¹ to 1080 cm⁻¹ is likely to provide the most reliable TFE concentrations.

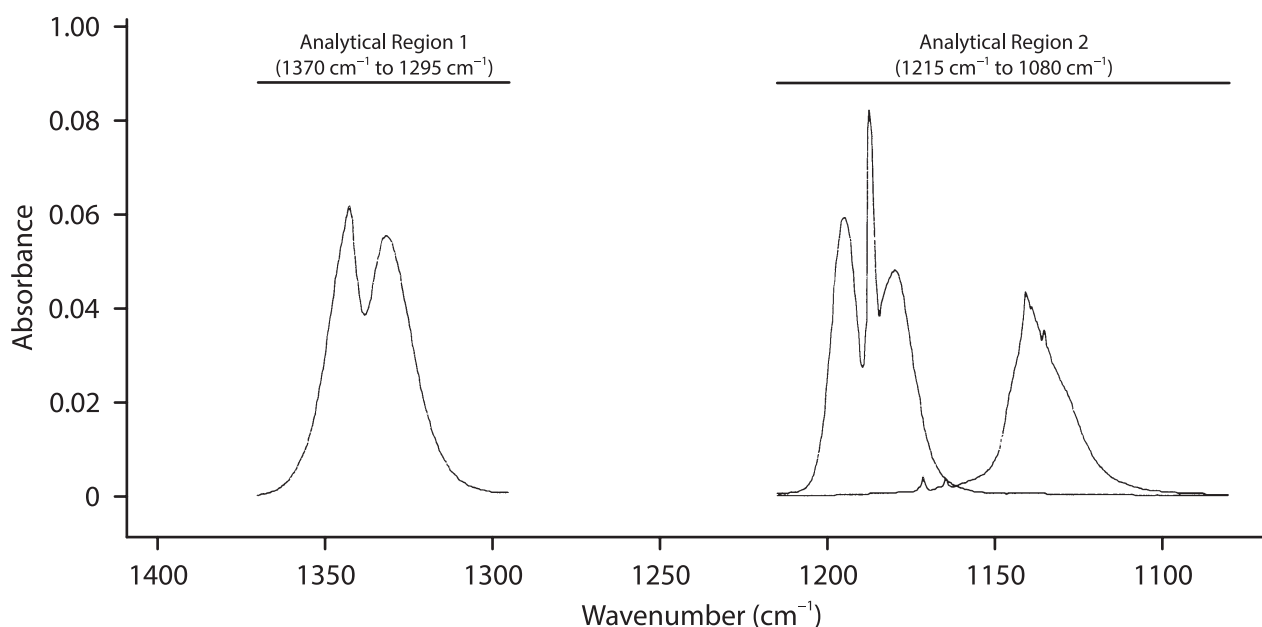

Figure E6. TFE and DFE spectra for absorbance area calculations.

Table E2. LODs for TFE and DFE from RSA analysis of water reference spectra

| Analytical Region (cm ⁻¹) | Compound | Reference Spectra | | | System Configuration | | |
|---------------------------------------|----------|-------------------|---------------|-------------------------------------|-------------------------|-------|---------------------|
| | | File Name | CPP (ppm · m) | Absorbance Area (cm ⁻¹) | RSA (cm ⁻¹) | L (m) | Estimated LOD (ppm) |
| 1370 to 1295 | TFE | tfe05.spc | 256.7 | 16.03 | 0.431 | 10.0 | 0.69 |
| 1215 to 1080 | TFE | tfe05.spc | 256.7 | 13.97 | 0.093 | 10.0 | 0.17 |
| 1215 to 1080 | DFE | dfe05.spc | 197.8 | 8.72 | 0.093 | 10.0 | 0.21 |

E2. LSF Determinations of TFE and DFE Concentrations

Presented in this section is a description of an LSF analysis for the two compounds TFE and DFE in ambient air samples. As is always the case before actual measurements are taken, no actual sample data for mixtures of the compounds in the assumed matrix (ambient air) were available as these analyses were performed. Accordingly, the following description is based on synthetic spectra generated from available reference spectra for TFE, DFE, and water.

In order to *not* overestimate the effectiveness of the FTIR technique, the noise levels in the synthetic sample spectra were artificially raised and the reference spectra used are not those most likely to provide an optimal analysis. This is the most prudent course available to an analyst attempting to predict the performance of the FTIR method under essentially unknown conditions and it is the course recommended by the authors to analysts who find themselves in this common situation.

Estimates of the LOD for this sample matrix (see section E1) indicate that the analytical region from 1215 cm⁻¹ to 1080 cm⁻¹ will likely provide the most reliable TFE and DFE concentrations. The system configuration parameters used in those estimates are assumed to hold in the following description.

E2A. Generation and Analysis of Synthetic Sample Spectra of TFE and DFE

Table E3 describes the mathematical generation of synthetic samples for the following LSF analysis description. Each sample spectrum consists of the sum of scaled reference spectra for TFE (tfe4.spc, CPP = 208.3 ppm · m), DFE (dfeav05.spc, CPP = 197.8 ppm · m) and water (wat02bl.spc). The scaling factors indicated in Table E3 were used to generate synthetic sample spectra at the listed concentrations and the assumed absorption path length of 10.0 m.

Table E3. Parameters used to generate synthetic sample spectra containing TFE, DFE, and water

| TFE Scaling Factor | TFE Synthetic Concentration (ppm) | DFE Scaling Factor | DFE Synthetic Concentration (ppm) | Water Scaling Factor | Synthetic Sample Spectrum File Name |
|--------------------|-----------------------------------|--------------------|-----------------------------------|----------------------|-------------------------------------|
| 0 | 0 | 0 | 0 | 0.6 | S001.spc |
| 0 | 0 | 0 | 0 | 1.2 | S002.spc |
| 1.200 | 25.0 | 1.264 | 25.0 | 0.6 | S551.spc |
| 1.200 | 25.0 | 0.253 | 5.00 | 0.6 | S511.spc |
| 0.240 | 5.00 | 1.264 | 25.0 | 0.6 | S151.spc |
| 1.200 | 25.0 | 1.264 | 25.0 | 1.2 | S552.spc |
| 1.200 | 25.0 | 0.253 | 5.00 | 1.2 | S512.spc |
| 0.240 | 5.00 | 1.264 | 25.0 | 1.2 | S152.spc |

A spectrum representing random absorbance noise was added to each synthetic spectrum. The noise spectrum was generated using the function RANDOM within the program GRAMS/32 V4.11 (Galactic, Inc.; see the Array Basic User's Guide, V4.1, page 316); similar functions are also available in other spreadsheet software programs. For the noise spectrum R , with discrete absorbance values R_i for wavenumbers $i = p$ to q , the root mean square (RMS) absorbance noise N_{RMS} (see also Equation B2, which defines the RSA), calculated over the appropriate analytical region(s) according to

$$N_{\text{RMS}} = \sqrt{\sum_{i=p}^{i=q} \frac{R_i^2}{q-p}}, \quad (\text{Equation E2})$$

was 0.00034 in the region 1438 cm^{-1} to 1282 cm^{-1} ; this is very close to the value obtained from actual absorbance spectra (provided by MIDAC Corporation) recorded with the quoted system configuration in the region 1005 cm^{-1} to 932 cm^{-1} . The synthetic spectra represent four different mixtures of TFE and DFE (including one "mixture" that contains neither compound), each at two different moisture levels.

Table E4 lists the results of a LSF analysis (program 4FTIMD V15, Rho Squared; see reference 14) for TFE, DFE, and water in the analytical region 1215 cm^{-1} to 1080 cm^{-1} using the reference spectral files TFE3.spc (CPP = 133.2 ppm · m), dfeav04.spc (CPP = 133.3 ppm · m), and wat01bl.spc. Note that these are not the same reference spectra that were used in the generation of the synthetic sample spectra and that the results for water are in arbitrary units. The analysis included the determination of two baseline correction parameters along with the compound concentrations.

Table E4. Original LSF results for original synthetic sample spectra containing TFE, DFE, and water

| Synthetic Sample Spectrum File Name | TFE* | | | DFE [†] | | | Water [‡] | |
|-------------------------------------|-------------------------------|------------------|--------------------------------|-------------------------------|------------------|--------------------------------|------------------------|--------------------------------|
| | Synthetic Concentration (ppm) | LSF Result (ppm) | LSF 3 σ Uncertainty (%) | Synthetic Concentration (ppm) | LSF Result (ppm) | LSF 3 σ Uncertainty (%) | LSF Result (arbitrary) | LSF 3 σ Uncertainty (%) |
| S001.spc | 0 | 0.02 | 52.5 | 0 | 0.07 | 13.7 | 1.12 | 1.23 |
| S002.spc | 0 | 0.03 | 32.2 | 0 | 0.14 | 8.95 | 2.24 | 0.80 |
| S551.spc | 25.0 | 24.41 | 0.26 | 25.0 | 24.30 | 0.29 | 0.87 | 11.8 |
| S511.spc | 25.0 | 24.43 | 0.25 | 5.00 | 4.88 | 1.43 | 0.87 | 11.5 |
| S151.spc | 5.00 | 4.88 | 0.41 | 25.0 | 24.33 | 0.09 | 1.07 | 3.04 |
| S552.spc | 25.0 | 24.43 | 0.26 | 25.0 | 24.35 | 0.29 | 1.99 | 5.20 |
| S512.spc | 25.0 | 24.45 | 0.26 | 5.00 | 4.95 | 1.43 | 1.99 | 5.11 |
| S152.spc | 5.00 | 4.90 | 0.43 | 25.0 | 24.39 | 0.10 | 2.19 | 1.56 |

*For TFE, excluding samples S001 and S002, the average difference between the synthetic concentration and the LSF result was 2.24%. The average 3 σ uncertainty was 0.31%.

[†]For DFE, excluding samples S001 and S002, the average difference between the synthetic concentration and the LSF result was 2.34%. The average 3 σ uncertainty was 0.61%.

[‡]For water, excluding samples S001 and S002, the average 3 σ uncertainty was 6.38%.

The LSF results for the non-zero TFE and DFE spectra are consistently good, being different from the synthetic concentrations less than 3% in every case. The concentration uncertainties listed in Table E4 are the statistically determined 3 σ values from the LSF analyses. These percent uncertainty parameters and the visual appearance of the LSF residual spectra are important indicators of the quality of the least squares analysis and are discussed further in the following section.

The TFE and DFE results for the two synthetic spectra that contain no absorption features of TFE and DFE (S001 and S002) are of interest and importance. The LSF concentration results are small. (Their maximum is 0.14 ppm). They are smaller in each case than the LOD estimates of Table E2 and their corresponding 3 σ uncertainties from this LSF analysis are smaller still. Unfortunately, no consensus exists on the exact mathematical relationship between the LODs calculated as described in this document and the 3 σ concentration uncertainties. This statement is supported by the contents of section A2 in reference 4 — a consensus document — that prescribes three different methods for calculating LODs (or, in the terminology of reference 4, “minimum detectable concentrations”). These three prescriptions include one similar to the LOD method prescribed in this document and one that is based on the concentration uncertainties derived from spectra similar to S001 and S002. In this limited example, two of the three prescriptions included in reference 4 provide very different results and they indicate that the LOD calculation described in this document provides the most conservative estimate — that is, the highest estimate — of the three LOD prescriptions of reference 4.

E2B. Analyses of Synthetic Sample Spectra with an Interfering Compound

Every compound-specific quantitative analytical technique, including FTIR spectrometry, can fail to provide accurate results when interfering compounds appear in a sample. However, the results of a mathematical FTIR spectral analysis designed for a particular set of compounds provides clues to its failure in the presence of interferants. An experienced analyst can often adjust the analysis to accommodate the interferants and provide accurate results.

To illustrate this important aspect of FTIR spectrometry, a synthetic interference was introduced to the spectra described in Table E3. Scaled versions of a reference spectrum (hfpav06.spc, 256.6 ppm · m) of the compound hexafluoropropylene (HFP), representing the compound at two concentrations (5.00 and 10.0 ppm), were added to the original synthetic spectra. The resulting final synthetic sample spectra

are described in Table E5 below. The least squares analysis described above for TFE and DFE only, when applied to these spectra containing spectral features of HFP, gives the results shown in Table E6 below.

Table E5. Parameters used to generate synthetic sample spectra containing TFE, DFE, water, and HFP

| Original Synthetic Sample Spectrum File Name | HFP Scaling Factor | HFP Synthetic Concentration (ppm) | Final Synthetic Sample Spectrum File Name |
|--|--------------------|-----------------------------------|---|
| S001.spc | 0.195 | 5.00 | S0011.spc |
| S002.spc | 0.390 | 10.0 | S0022.spc |
| S551.spc | 0.195 | 5.00 | S5511.spc |
| S151.spc | 0.195 | 5.00 | S1511.spc |
| S512.spc | 0.195 | 5.00 | S5121.spc |
| S511.spc | 0.390 | 10.0 | S5112.spc |
| S552.spc | 0.390 | 10.0 | S5522.spc |
| S152.spc | 0.390 | 10.0 | S1522.spc |

Table E6. Original LSF results for final synthetic sample spectra containing TFE, DFE, water, and HFP

| Synthetic Sample Spectrum File Name | TFE* | | | DFE [†] | | | Water [‡] | |
|-------------------------------------|-------------------------------|------------------|--------------------------------|-------------------------------|------------------|--------------------------------|------------------------|--------------------------------|
| | Synthetic Concentration (ppm) | LSF Result (ppm) | LSF 3 σ Uncertainty (%) | Synthetic Concentration (ppm) | LSF Result (ppm) | LSF 3 σ Uncertainty (%) | LSF Result (arbitrary) | LSF 3 σ Uncertainty (%) |
| S0011.spc | 0 | 1.00 | 39.6 | 0 | -1.58 | 26.5 | 1.65 | 0.89 |
| S0022.spc | 0 | 2.01 | 39.5 | 0 | -3.16 | 26.4 | 3.29 | 1.78 |
| S5511.spc | 25.0 | 25.06 | 1.51 | 25.0 | 22.65 | 1.89 | 1.43 | 43.3 |
| S5112.spc | 25.0 | 25.73 | 2.90 | 5.00 | 1.57 | 53.8 | 1.99 | 61.4 |
| S1511.spc | 5.00 | 5.53 | 6.64 | 25.0 | 22.67 | 1.84 | 1.63 | 37.0 |
| S5522.spc | 25.0 | 25.73 | 2.90 | 25.0 | 21.05 | 4.01 | 3.10 | 39.2 |
| S5121.spc | 25.0 | 25.09 | 1.52 | 5.00 | 3.29 | 13.1 | 2.55 | 24.4 |
| S1522.spc | 5.00 | 6.20 | 11.87 | 25.0 | 21.09 | 3.96 | 3.30 | 36.4 |

*For TFE, excluding samples S001 and S002, the average 3 σ uncertainty was 4.56%.

[†]For DFE, excluding samples S001 and S002, the average 3 σ uncertainty was 13.1%.

[‡]For water, excluding samples S001 and S002, the average 3 σ uncertainty was 40.3%.

The average 3 σ uncertainties shown in Table E4 (those of the original LSF analysis *without* HFP interference) and Table E6 (those of the original LSF analysis *with* HFP interference) are clearly quite different. Averaged over the six synthetic spectra containing TFE and DFE in each case, the (absolute) percent concentration uncertainties for TFE, DFE, and water are greater for the spectra with HFP interference. For TFE and DFE, the average percent uncertainties of Table E6 are over ten times greater than those of Table E4. This exercise shows that:

- For sample spectra containing substantial TFE and DFE concentrations, the HFP interference causes large increases in the TFE and DFE relative absolute concentration uncertainties.
- For sample spectra containing low or zero concentrations TFE and DFE, the relative absolute uncertainties are NOT a reliable indicator of the HFP interference. However, for such spectra, the concentration results themselves are often clearly unreliable; note that the DFE concentration

results are negative *and* large compared to the LOD estimate for this compound. (Note also that negative concentration results that are *small* compared to the LOD are statistically valid and do not necessarily indicate a failure of the analysis.)

If the concentration results show anomalies such as those noted above, the residual spectra from the analyses will also exhibit anomalous behavior. This is illustrated in Figure E7, which shows the residual spectra for four analyses. Compared to the residual spectra resulting from analyses of spectra without the HFP interference, those with HFP interference show large absorbance features that cannot be modeled by the three reference spectra employed. The analyst needs to identify the interfering compound before proceeding. This can often be done by visually comparing the suspect residual spectra to reference spectra of a number of likely interferants, as illustrated in Figure E8.

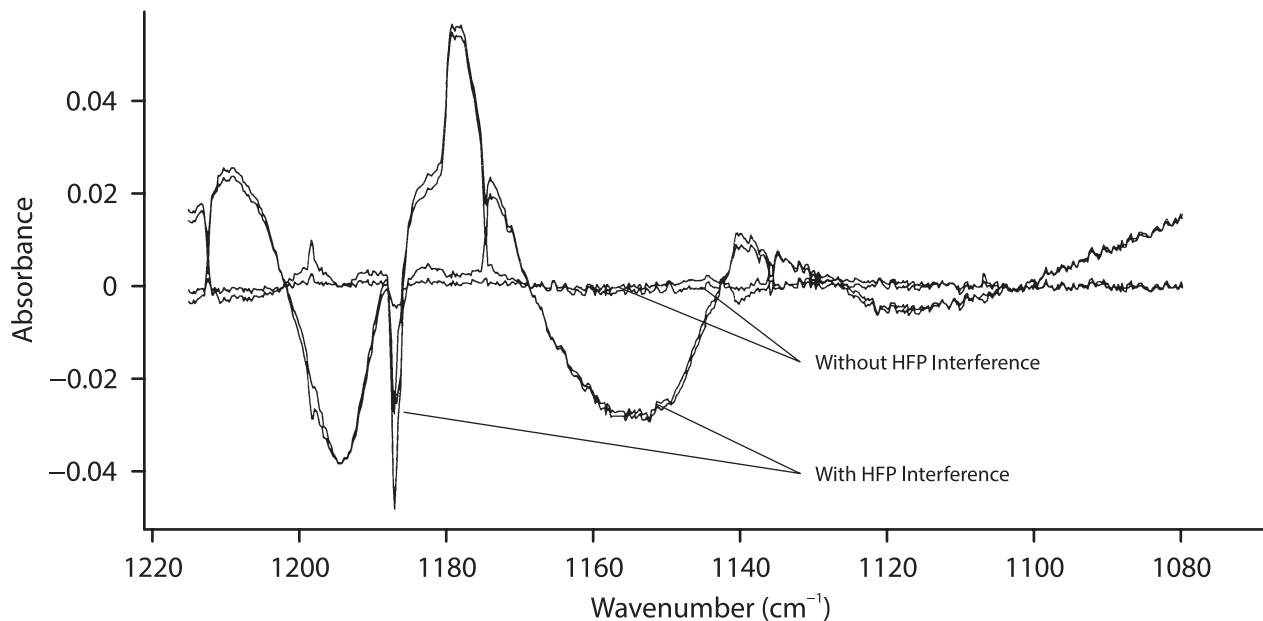

Figure E7. Residual spectra with and without HFP interference.

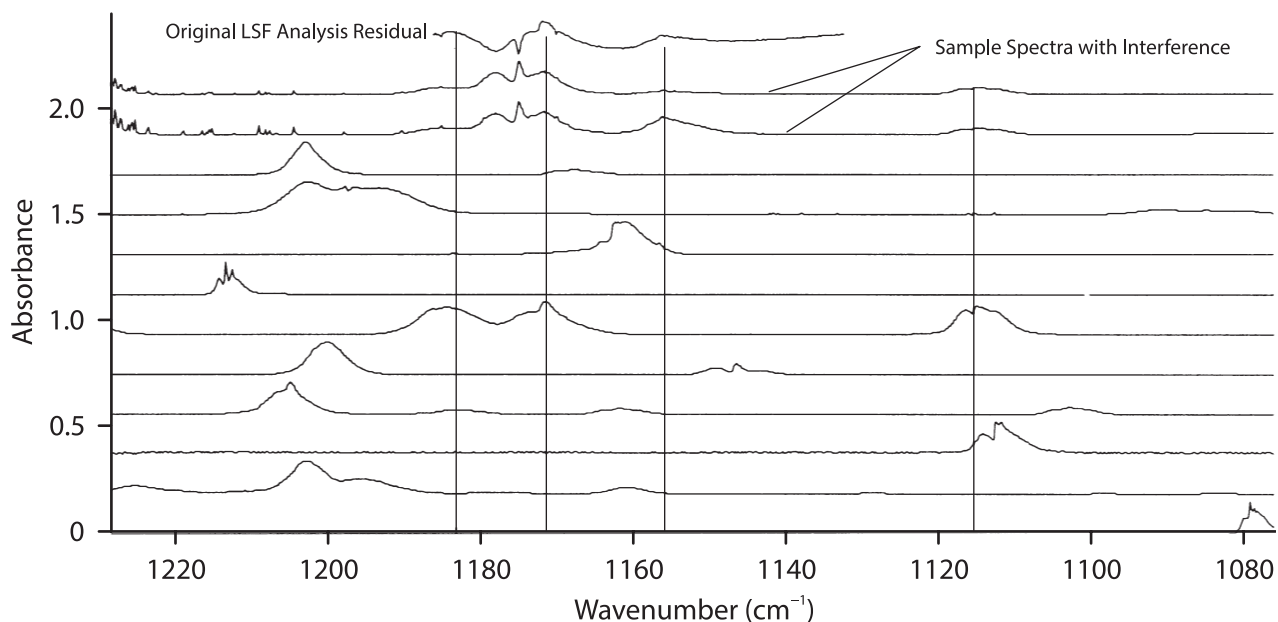

Figure E8. Comparisons of residual, sample, and reference spectra.

Figure E8 shows that the positions of three major relative maxima in the residual spectrum (top trace) correspond well to only one of the nine candidate reference spectra in the lower traces of the figure. (The nine spectra shown are all of light, partially or fully fluorinated hydrocarbons.) An additional absorbance band from this single reference spectrum also corresponds to a large peak in both of the sample spectra (second and third traces from top of the figure).

A closer examination of this reference spectrum — that of HFP, of course — is illustrated in Figure E9. It clearly shows a close relationship between the shape of the residual spectrum and the absorption features of HFP. The relationship is not exact because the sample spectrum has had incorrect amounts of the compounds TFE and DFE subtracted and this distorts the residual spectrum.

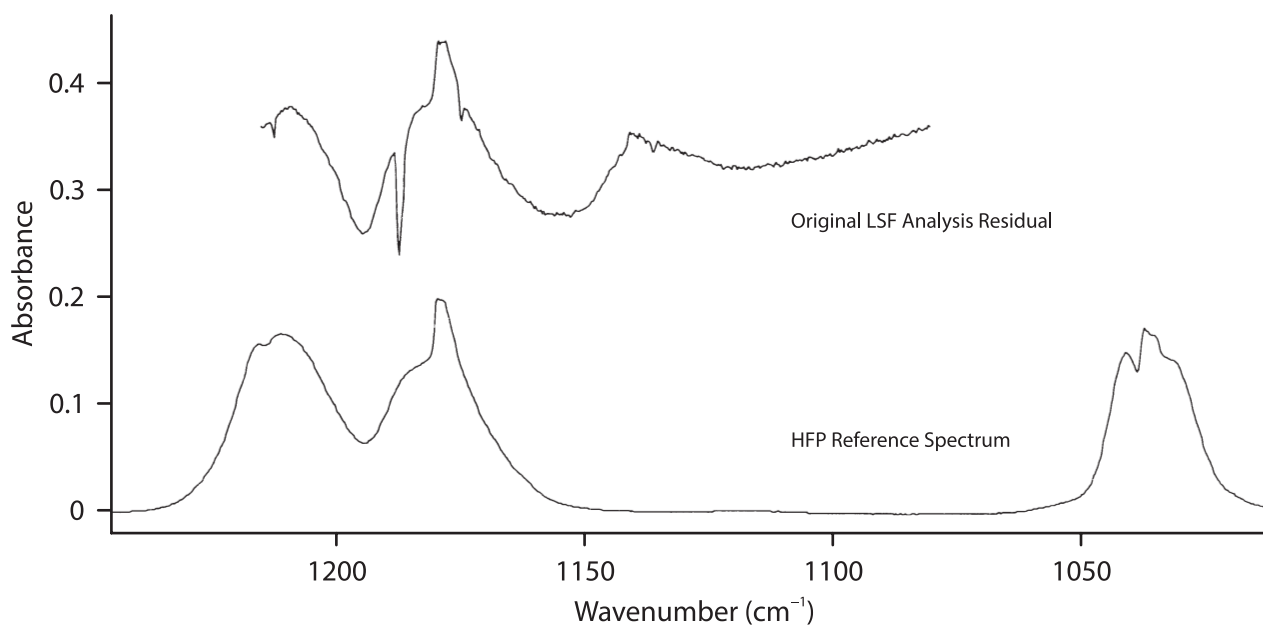

Figure E9. Original LSF residual and HFP reference spectra.

Though this identification is tentative, it can be tested by including HFP in the LSF analysis. Table E7 shows the TFE, DFE, and water concentrations resulting from an analysis identical to those described above except for the addition of HFP as a fourth compound. (As usual, an HFP reference spectrum different from the one used to add the synthetic interference was employed in the analysis.) To facilitate comparisons with the preceding tables, the HFP results have been excluded from Table E7; they were in all cases similar in quality to those obtained for the other compounds.

Table E7. Final LSF results for final synthetic sample spectra containing TFE, DFE, water, and HFP

| Synthetic Sample Spectrum File Name | TFE* | | | DFE [†] | | | Water [‡] | |
|-------------------------------------|-------------------------------|------------------|--------------------------------|-------------------------------|------------------|--------------------------------|------------------------|--------------------------------|
| | Synthetic Concentration (ppm) | LSF Result (ppm) | LSF 3 σ Uncertainty (%) | Synthetic Concentration (ppm) | LSF Result (ppm) | LSF 3 σ Uncertainty (%) | LSF Result (arbitrary) | LSF 3 σ Uncertainty (%) |
| S0011.spc | 0 | 1.00 | 39.6 | 0 | -1.58 | 26.5 | 1.65 | 0.89 |
| S0022.spc | 0 | 2.01 | 39.5 | 0 | -3.16 | 26.4 | 3.29 | 1.78 |
| S5511.spc | 25.0 | 24.43 | 0.27 | 25.0 | 24.27 | 0.33 | 0.87 | 12.1 |
| S5112.spc | 25.0 | 24.45 | 0.27 | 5.00 | 4.81 | 1.72 | 0.88 | 12.34 |
| S1511.spc | 5.00 | 4.91 | 0.44 | 25.0 | 24.27 | 0.11 | 1.08 | 3.23 |
| S5522.spc | 25.0 | 24.46 | 0.28 | 25.0 | 24.27 | 0.35 | 1.99 | 5.51 |
| S5121.spc | 25.0 | 24.45 | 0.27 | 5.00 | 4.92 | 1.63 | 1.99 | 5.25 |
| S1522.spc | 5.00 | 4.94 | 0.57 | 25.0 | 24.29 | 0.14 | 2.20 | 2.05 |

*For TFE, excluding samples S0011 and S0022, the average 3 σ uncertainty was 0.35%.

[†]For DFE, excluding samples S0011 and S0022, the average 3 σ uncertainty was 0.71%.

[‡]For water, excluding samples S0011 and S0022, the average 3 σ uncertainty was 6.74%.

The results show that inclusion of HFP in the analysis yields results of the original (high) quality shown in Table E3 for TFE, DFE, and water. The percent relative uncertainties are slightly higher in the final analysis than in the original analysis; this is to be expected because the same amount of spectral information is being used to determine an additional parameter in the final analysis. The quality of the analysis could probably be further improved by extending the analytical region to include the entire HFP absorbance band shown in Figure E9.



Formula: Table 1

MW: Table 1

CAS: Table 1

RTECS: Table 1

METHOD: 3900, Issue 1

EVALUATION: FULL

Issue 1: 30 August 2018

OSHA: Table 3

NIOSH REL: Table 3

Other OELs: [1-3]

PROPERTIES: Table 1

ANALYTES: ethanol, 2-propanol, acetone, 2,3-butanedione, 2,3-pentanedione, 2,3-hexanedione, dichloromethane, trichloromethane, hexane, benzene, toluene, ethylbenzene, *o*-xylene, *m,p*-xylene, methyl methacrylate, α -pinene, *d*-limonene

| SAMPLING | | MEASUREMENT | |
|--|--|--|--|
| SAMPLER: | FUSED-SILICA LINED STAINLESS STEEL CANISTER, 6 L, 450, or 400 mL | TECHNIQUE: | GAS CHROMATOGRAPHY, MASS SPECTROMETRY |
| FLOW RATE: | 0.06 to 50 mL/min. See SAMPLING section | ANALYTE: | Compounds listed in Table 1 |
| VOL-MIN: | Depends on canister volume. See SAMPLING section | PRECONCENTRATION VOLUME: | 25 to 500 mL injection (ppb-levels) for a 6L canister, 25 to 250 mL injection (ppb-levels) for a 400/450 mL canister, 1 mL loop (ppm-levels) |
| SHIPMENT: | Routine | PRECONCENTRATION CONDITIONS: | Module 1 (empty): Focused @ -20° C, desorbed @ 10° C, baked @ 150° C (7 min); Module 2 (glass beads): Focused @ -80° C, desorbed @ 180° C, baked @ 190° C; Module 3 (focuser): Focused @ -150° C. |
| SAMPLE STABILITY: | 58 days @ 25° C (30 days for ethanol, 2-propanol, and acetone @ 10 ppb; 21 days for α -pinene and <i>d</i> -limonene @ 0.8 ppm) | GC/MS CONDITIONS: | Injection: preconcentrator transfer line 100° C Detector: 280° C Column: 35° C (2 min hold) to 170° C (ramp 8° C/min), ramp 20° C/min to 220° C (3 min hold) MS Source: 230° C Quadrupole: 150° C Solvent delay: 4.5 min MS Scan: 35-350 amu |
| BLANKS: | 1 field blank per set | CARRIER GAS: | Helium, 1 mL/min |
| ACCURACY | | COLUMN: | Capillary, fused silica, 60 m x 0.32-mm ID; 1- μ m film 100% dimethylpolysiloxane |
| RANGE STUDIED: | Tables 4a and 4b | CALIBRATION: | Gas phase analytes in canisters |
| BIAS: | Tables 4a and 4b | RANGE: | Tables 4a and 4b |
| OVERALL PRECISION ($\bar{S}_{r,T}$): | Tables 4a and 4b | ESTIMATED LOD: | Tables 4a and 4b |
| ACCURACY: | Tables 4a and 4b | PRECISION (\bar{S}_r): | Tables 4a and 4b |

APPLICABILITY: The method was developed for measuring a range of volatile organic compounds in healthcare settings [4], but may be used in other occupational settings. The method was developed to measure the following analytes: ethanol, acetone, 2-propanol, dichloromethane, hexane, trichloromethane, 2,3-butanedione, 2,3-pentanedione, and 2,3-hexanedione, benzene, methyl methacrylate, toluene, ethylbenzene, *m,p*-xylene, *o*-xylene, α -pinene, and *d*-limonene. The working range is 0.24 to 22 ppb

for ppb-level analysis and 0.07 to 2.0 ppm for ppm-level analysis depending on analyte (Table 4a). This method may be applicable for other volatile organic compounds that exhibit acceptable stability, bias, precision and accuracy. Alternate detectors (e.g., flame ionization detector, electron capture detector, thermal conductivity detector, time-of-flight or quadrupole time-of-flight mass spectrometer), canister volumes, GC columns, internal standards and equipment may be used after method performance has been assessed and shown to be within acceptable limits. Training on pressure dilution techniques and preconcentration systems as well as proficiency testing should be periodically conducted to ensure operating laboratories maintain optimal canister method performance.

INTERFERENCES: Other compounds with similar retention times and quantitation ions may interfere (e.g., alcohols, ketones, aromatics, beta-pinene). For example, vinyl acetate has the same molecular weight as 2,3-butanedione and has the same retention time elution on the recommended column. High humidity samples that are pressurized may form condensed water causing losses of water-soluble compounds. Water content should be managed during preconcentration of the sample by purging traps with helium, reducing the sample injection volume onto the preconcentrator, or splitting the sample stream prior to concentration and/or gas chromatograph injection.

OTHER METHODS: This is a method for the determination of VOCs, C1 to C10, in mixed exposure environments. The method has been modified from the Environmental Protection Agency (EPA) method TO-15 to include specific chemicals and low-ppm concentration volatile analysis [5]. ASTM D5466 is also available as guidance for canister sampling and analysis [6].

REAGENTS:

1. Ethanol, reagent grade*
2. 2-Propanol, reagent grade*
3. Acetone, reagent grade*
4. 2,3-Butanedione, reagent grade*
5. 2,3-Pentanedione, reagent grade*
6. 2,3-Hexanedione, reagent grade*
7. Dichloromethane, reagent grade*
8. Trichloromethane, reagent grade*
9. Hexane, reagent grade*
10. Benzene, reagent grade*
11. Toluene, reagent grade*
12. Ethylbenzene, reagent grade*
13. *o*-Xylene, reagent grade*
14. *m*-Xylene, reagent grade*
15. *p*-Xylene, reagent grade*
16. Methyl methacrylate, reagent grade*
17. α -Pinene, reagent grade
18. *d*-Limonene, reagent grade*
19. Ultra-high purity air
20. Ultra-high purity nitrogen
21. Ultra-high purity helium
22. Internal standard cylinder @ 20 ppb
(bromochloromethane; 1,4-difluorobenzene;
chlorobenzene-d5; and
bromofluorobenzene)
23. Distilled, deionized water, 18 MOhm, low VOC
content

*See SPECIAL PRECAUTIONS.

EQUIPMENT:

1. Gas chromatograph/mass spectrometer system capable of attaching to preconcentrator system
2. Whole-air preconcentrator system capable of variable injection volumes from 25 to 500 mL
3. Canister autosampler with 1-mL loop injection system
4. Gas dilution system capable of measuring pressure transfers
5. Heated canister cleaning system capable of evacuating canister to 0.0066 kPa prior to sampling and cycling between vacuum and humidified gas
6. Capillary or diaphragm flow controller for restricted flow sampling, or fitting for instantaneous sampling with 2- μ m, sintered, stainless steel particle filter
7. 400 mL, 450 mL, or 6 L fused-silica lined coated canisters
8. Gas-tight syringes, 2.5 mL, 1 mL, 250 μ L, 100 μ L, 25 μ L and 10 μ L
9. Disposable glass pipets
10. 2 L glass bulb

SPECIAL PRECAUTIONS: Dichloromethane and trichloromethane are confirmed animal carcinogens and benzene is a confirmed human carcinogen (see International Agency for Research on Cancer (IARC)). Terpenes are flammable and considered irritants. Perform all standards preparation in a well-ventilated

hood. Wear appropriate personal protective equipment during sampling activities and analysis. It is essential that suitable gloves, eye protection, laboratory coat, etc. be used when working with the chemicals.

SAMPLING:

1. Evacuate canister to 0.0066 kPa prior to sampling.
2. Sampling may be performed with a flow controller (e.g., diaphragm or capillary) into a large canister (e.g., 6 L) for area sampling or a small canister (e.g., 400 or 450 mL) for personal sampling. Selection of the appropriate flow controller and flow rate will depend upon the size of canister being used and sampling period that is necessary to characterize exposures.
3. For diaphragm flow controllers, follow the manufacturers procedures for calibration to an appropriate flow rate (e.g., 10 mL/min for a 6 L canister for an 8-hour work shift) prior to each day of sampling; the final pressure in the canister should be less than 84.1 kPa.
4. For capillary flow controllers, the flow is governed by the length and internal diameter of the capillary. Use a flow controller that will fill the can volume to 30.4 kPa during your sampling period. Do not exceed a final sample pressure of 50.6 kPa.
5. Use a 2- μ m, sintered, stainless steel particle filter to protect the flow controllers and canisters when sampling in dusty atmospheres.

SAMPLE PREPARATION:

6. For ppb-level analysis, attach the canister to the preconcentrator via an autosampler or direct transfer line. If sample needs to be pressurized to increase sample volume prior to analysis, perform pressure dilution with ultra-high purity (UHP) nitrogen or air and apply dilution factors in calculation. Final sample pressure after analysis should be greater than 50.6 kPa to limit potential for sample dilution due to system leakage.
7. For ppm-level analysis, pressurize the canister (e.g., 152 kPa or follow instrument manufacturer's recommendation) in order to obtain a sufficient excess pressure to flush the 1 mL loop. An alternative to using the loop for quantitation could be running a loop or low volume injection of the canister to investigate the analyte concentration range. Then, perform pressure dilutions into ppb-level calibration curve.

NOTE: Allow samples or calibration standards that are pressurized a minimum of 6 hours to equilibrate prior to analysis. Pressure dilutions greater than 50x should be performed with successive dilutions into additional canisters with equilibration time allowed at each step.

CALIBRATION AND QUALITY CONTROL:

8. Tune the mass spectrometer and calibrate with standards over the range 1 to 20 ppb (25 to 500 mL nominal injection volume) and 0.2 to 2 ppm (1 mL loop flushed with 100 mL of sample). Five to seven calibration points within the dynamic range should be used. Internal standard (50 mL at 20 ppb) is added to the preconcentrator prior to standard or sample transfer.
9. A mixture of the analytes must be produced before gas-phase standard preparation.
10. Gas-phase standards may be prepared in 2 L glass bulbs by adding a known volume of a neat chemical mixture (see Calculation section) to the vessels. The mass injected into the bulb is determined from the concentration of analyte in the mixture and the volume of mixture delivered to the vessel.

NOTE: Alcohols and ketones may react in the presence of heat. The heated-bulb preparation method is not recommended for alcohols and ketones when prepared in the same heated bulb as the reaction will change the gas concentration produced. Two alternatives to the heated-bulb

preparation method are generation without heat in a large inert bag (e.g., tedlar) protected from light or purchasing a calibration cylinder from a reference material supplier.

11. The vessel is heated to 60° C for 30 minutes and allowed to cool to room temperature before a small gas volume is transferred to evacuated-calibration canisters via a gas-tight syringe. An alternative to standard preparation by a heated glass bulb is to purchase gas standards at known concentrations and use a gas dilution system to measure pressure transfers. Gas standards should be purchased from a reputable, accredited reference material producer (e.g., ISO 17034 [7] accreditation recommended). A gas standard at approximately 2 ppm of each of the 17 compounds (balance nitrogen) has been stable for 2 years in a pressurized aluminum cylinder with only a $\pm 2\%$ deviation from the original certified value.
12. Add 80 μL of clean distilled water to an evacuated 6 L canister, add gas standard, and dilute with UHP nitrogen or air to 172 kPa (i.e., $\sim 40\%$ RH).
13. Develop response factors for each analyte to the closest internal standard using the mass spectrometer quantitation software and the appropriate quantitation (primary) ion. Response factors (RF) are calculated as follows [8]:

$$RF = \frac{A_x * C_{is}}{A_{is} * C_x}$$

Where:

A_x = area of the quantitation ion for the analyte (counts);

A_{is} = area of the quantitation ion for the internal standard (counts);

C_{is} = concentration of internal standard (ppb); and

C_x = concentration of the analyte (ppb).

14. A humidified (e.g., $\sim 40\%$ RH) laboratory blank and humidified (e.g., $\sim 40\%$ RH) 10 ppb check standard must be analyzed within a 24 hour period of sample analysis. Perform a full calibration when the check standard falls outside established acceptance criteria as developed by the laboratory. Check standard recoveries of 90% to 110% are achievable but may be higher or lower depending on instrumentation. A replicate sample analysis should be conducted every 10 samples, when possible, to assess measurement repeatability. A check standard should be analyzed near the end of the analytical sequence to ensure recoveries of each compound are within 80% to 120%.

MEASUREMENT:

15. Set preconcentrator/GC/MS according to manufacturer's recommendations and to conditions given on page 3900-1.
16. Inject 50 mL of internal standard at 20 ppb.
17. Inject between 200 and 500 mL of sample for ppb-level analysis and 1 mL of sample for ppm-level analysis. Alternative injection volumes may be used as long as performance is verified prior to sample analysis.

NOTE 1: If peak area is above linear range of the working standards, dilute with UHP nitrogen using a gas dilution system or inject smaller sample volumes, reanalyze and apply the appropriate dilution factor in calculations.

NOTE 2: *m*- and *p*-Xylene isomers co-elute on the specified column and should be analyzed/reported together.

CALCULATIONS:

18. Calculation for the concentration of analyte in calibration standard (C_{bulb} ; ppm) in the glass bulb:

$$C_{bulb} = \frac{C_a V_m Y * 22.4}{MW_s * V_{bulb}} * \frac{T_{lab}}{273.15} * \frac{760}{P_{lab}}$$

Where:

C_a = concentration of analyte in the mixture (mg/mL);

V_m = volume of mixture injected in bulb (mL);

Y = purity of analyte (scale 0 to 1);

MW_s = molecular weight of analyte (g/mol);

V_{bulb} = volume of glass bulb (m³) determined experimentally;

T_{lab} = temperature of the laboratory (K);

P_{lab} = pressure of the lab (mm Hg).

NOTE: 760 is assuming standard atmospheric pressure. 273.15 is International Union of Pure and Applied Chemistry (IUPAC) standard temperature and 22.4 is molar volume at STP.

19. Transfer a small aliquot of the gas from the bulb to an evacuated canister for calibration standards.

20. Calculate the final concentration in the canister (C_{final} ; ppb) based on:

$$C_{final} = C_{bulb} * 1000 * \frac{V_{inj}}{V_{can}} * \frac{P_{atm}}{P_f}$$

Where:

C_{bulb} = concentration in glass bulb (ppm);

V_{inj} = volume transferred to the canister (mL);

V_{can} = volume of the canister (mL);

P_{atm} = atmospheric pressure (kPa); and

P_f = final canister pressure (kPa).

21. Determine the analyte concentration (C_x) in ppb or ppm according to the following equation:

$$C_x = \frac{A_x * C_{IS}}{A_{IS} * RF}$$

Where:

A_x = area of the primary ion for the analyte (counts);

A_{IS} = area of the primary ion for the internal standard (counts);

C_{IS} = concentration of internal standard (ppb);

RF = response factor calculated using linear regression.

Note: Most data analysis software packages will calculate analyte concentration provided you enter the calibration information in the quantification database. Blank correction may be necessary when instrument or field blank results are consistent and above the analyte detection limit.

22. Dilution factors (ratio of final volume to initial volume) must be applied to standards or samples as applicable.

EVALUATION OF METHOD:

Method Accuracy

Bias, precision, accuracy and stability for 14 volatile organic compounds (ethanol, acetone, 2-propanol, dichloromethane, hexane, trichloromethane, benzene, methyl methacrylate, toluene, ethylbenzene, *m,p*-xylene, *o*-xylene, α -pinene, and *d*-limonene) at ppb-level and ppm-level concentrations [4] were determined using Kennedy et al. [9]. Three additional analytes (2,3-butanedione, 2,3-pentanedione, and

2,3-hexanedione) were added to the target list after this study and accuracy has been assessed during chamber studies (see section below). The upper and lower 95% confidence limits of the average bias were calculated (i.e., $\pm 1.96 \times \text{standard error}$). To be acceptable either both bias limits must have an absolute value less than 10%, or an absolute value of 10% must fall between the limits. For a method to meet the NIOSH "25% accuracy" criterion, the 95% confidence statistic for accuracy estimated with the hyperbolic approximation formula must be below 25%. The stability metric is a measure of bias comparing average concentration on day 30 or greater to average concentration on day zero; the absolute value of the stability metric must be less than 10% to be acceptable. Day 30 stability was obtained from LeBouf et al. [4]. Day 58 stability was obtained from NIOSH [10]. While method performance varied by analyte, the validation results demonstrate that this method is a viable air sampling and analytical methodology for measuring a wide range of air concentrations of select volatile organic compounds in mixed exposure environments.

For the preconcentration method used to measure ppb-level concentrations, all accuracy criteria were within acceptable limits for 16 of the 17 target analytes (Table 4a). 2-Propanol failed the 95% accuracy criterion at ppb-level concentrations and accuracy validation results are considered inconclusive, perhaps because the water management step in the preconcentration may have affected the concentrations of this analyte due to its polar nature. Ethanol, however, passed the accuracy criterion despite its similar polarity. Bias was acceptable for all 17 analytes. The average bias values for 2-propanol and methyl methacrylate were greater than 10% but still within acceptable parameters when 95% confidence limits were calculated; further evaluation to confirm or refute this excessive bias result is warranted, particularly because bias values may have been influenced by error introduced during the preparation of standards (e.g., liquid injection into glass bulb or concentration dilution). Storage stability of the 17 analytes was confirmed for 58 days at approximately 10 ppb for most analytes with the exception of ethanol, 2-propanol, and acetone (stable for 30 days) (Table 4a) [4, 10].

Because trichloromethane failed Bartlett's test of homogeneity [9] (i.e., precision varied across concentrations) for ppb-level, the accuracy value for this analyte displayed in Table 4a was not calculated based on a value for precision that was pooled across all concentrations investigated. Rather, the accuracy value was calculated based on the worst-case concentration-specific precision and bias and a modified accuracy calculation that accounts for the reduced degrees of freedom. Further investigation of the precision for trichloromethane using the ppb-level method is warranted. In the meantime, the method can be used to quantify this analyte, but the analyst must be cognizant of the concentration-dependence of measurement variability.

For the loop method used to measure ppm-level concentrations, all accuracy and bias criterion were within acceptable limits for each analyte (Table 4b). Bartlett's test demonstrated that measurement precision was non-homogeneous over concentrations for both dichloromethane and methyl methacrylate. The accuracy values for these two analytes were calculated based on the worst-case concentration-specific precision and bias and a modified accuracy calculation that accounts for the reduced degrees of freedom. All analytes were stable for 30 days, except α -pinene and *d*-limonene, which remained stable for 21 days (Table 4b). The shorter acceptable storage time for α -pinene and *d*-limonene may be due to losses from chemical reactions with other components of canister contents, particularly oxidizing species such as ozone or hydroxyl and nitrate radicals naturally found in indoor air [11, 12].

Inter-laboratory Study

An inter-laboratory study was conducted to estimate precision from nine laboratories [10]. Laboratories were recruited from American Industrial Hygiene Association (AIHA)-accredited or National Environmental Laboratory Accreditation Program (NELAP)-accredited laboratories which had the experience and equipment necessary to analyze canister samples. Precision estimates for repeatability ranged from 0.04 to 0.55 at ppb concentrations and from 0.1 to 0.47 for ppm concentrations. Precision estimates for

reproducibility ranged from 0.1 to 0.62 at ppb concentrations and from 0.19 to 0.58 at ppm concentrations, depending on analyte and nominal level. Plots of h and k statistics which measure between and within laboratory consistency indicated inconsistencies with reported results from laboratories 5, 6, and 7. These laboratories were investigated to determine the cause of the inconsistent results. Issues with storage time and adherence to the method protocol were encountered but results were retained due to the low number of laboratories participating. Training on pressure dilution techniques and preconcentration systems as well as proficiency testing should be periodically conducted to ensure operating laboratories maintain optimal canister method performance.

Chamber Studies

The canister method was challenged in laboratory chamber studies [10] under varying environmental conditions and concentrations of alpha-diketones to assess sampling and analytical accuracy following ASTM D6246 [13]. The following conditions were assessed: temperature, humidity, wind speed, and concentration. Bias pulse tests were performed to assess the bias associated with a known drop in flow rate (~13% over the sampling period) for capillary flow controllers. Flow rate bias (bias pulse) was assessed using the difference in measurements for peak exposures occurring at the beginning and end of the sampling period. Tests were also performed to assess inter-day and inter-sampler variation. A dynamic volatile organic compound generation and sampling system was used to produce known concentrations of challenge agents in a glass sampling chamber with 18 sampling ports. The system was placed in a large walk-in environmental control chamber to regulate temperature. Capillary flow controllers were constructed using Swagelok connections and deactivated fused-silica tubing to collect air samples at 15 mL/min for 15 minutes into a 450 mL canister to test the maximum recommended sampling fill pressure of 50.6 kPa. Canisters were pressurized with ultra-high purity nitrogen and analyzed using an autosampler/preconcentrator system attached to a gas chromatograph/mass spectrometer. Results were corrected for pressure dilution and compared to a theoretical concentration calculated from flow dilution of the gas standard used in the generation system. Accuracy was calculated for each target analyte for all conditions combined. Variance estimates for each factor influencing accuracy were used to apportion the relative influence of each test condition on the overall performance of the method. Upper confidence limits on accuracy (A_{95}) were below 0.25 for all analytes: 0.085 for diacetyl, 0.142 for 2,3-pentanedione, and 0.194 for 2,3-hexanedione. Overall precision was largest for 2,3-hexanedione at 0.061 with 27.4% of the total variance due to inter-day variability. The peak exposure condition (i.e., effect of a bias pulse given the flow rate drop over the sampling period) accounted for less than 6% of the variability regardless of analyte, meaning the known drop in flow rate from the capillary flow controller did not overly influence air sampling results. Additional VOCs (ethanol, acetone, isopropyl alcohol, dichloromethane, trichloromethane, methyl methacrylate, hexane, benzene, toluene, xylenes, α -pinene, *d*-limonene) were present during low and high humidity trials to assess the effect of humidity on method performance. For the high humidity trial ($n=10$), A_{95} for the additional VOCs were below 0.25 except for ethanol and methyl methacrylate. For the low humidity trial ($n=5$), A_{95} for the additional VOCs were below 0.25 except for ethanol and isopropyl alcohol. Canister method is a reliable, robust sampling and analytical method that may be used for a variety of analytes (e.g., C1 to C10) under varying environmental conditions.

Flow Controllers for Personal Sampling

Diaphragm flow controllers are heavy due to the stainless steel body holding the diaphragm making them inconvenient for personal sampling. The capillary flow controllers are light weight and provide a broad dynamic range of flow rates that enables full-shift (8-12 hours) sample collection in a 400/450mL canister [8]. With capillary flow controllers, the flow is governed by the length and internal diameter of the capillary and the pressure in the canister [8, 14]. As the canister fills with sample, the pressure differential between the atmosphere and the inside of the canister decreases. This decrease causes a slight, non-linear reduction in flow rate over time. The effect of the change can be mitigated by keeping the final sample volume in the canister at around 30% (but no greater than 50%). The effect of a known, decrease in flow

rate on bias has been assessed and will not overly influence time-integrated measurements of analyte concentration even when a peak concentration at the beginning or end of the sampling period is collected [10, 14].

Additional Guidance

Follow EPA guidelines for cleaning canisters, sampling train cleanliness, canister cleanliness, leak testing, and canister pressurization [5, 15]. Do not clean fused silica lined canisters with humidified air and heat above 80°C. Use humidified nitrogen and heat to clean fused silica lined canisters. ASTM D5466 is also available as guidance for canister sampling and analysis [6].

REFERENCES:

- [1] ACGIH [2018]. TLVs® and BEIs® based on the documentation of the Threshold Limit Values for chemical substances and physical agents and Biological Exposure Indices. Cincinnati, Ohio: American Conference of Governmental Industrial Hygienists.
- [2] Permanent Senate Commission for the Investigation of Health Hazards of Chemical Compounds in the Work Area [2016]. List of MAK and BAT values 2016; Maximum Concentrations and Biological Tolerance Values at the Workplace. Weinheim, Germany: Wiley-VCH Verlag GmbH & Co., <https://dx.doi.org/10.1002/9783527805983>.
- [3] Institute for Occupational Safety and Health of the German Social Accident Insurance (IFA) [2017]. GESTIS international limit values, <http://limitvalue.ifa.dguv.de/>.
- [4] LeBouf RF, Stefaniak AB, Virji MA [2012]. Validation of evacuated canisters for sampling volatile organic compounds in healthcare settings. *J Environ Monit* 14(3):977-983.
- [5] EPA [1999]. Compendium Method TO-15: Determination of volatile organic compounds (VOCs) in air collected in specially-prepared canisters and analyzed by gas chromatography/mass spectrometry (GC/MS). Cincinnati, OH, U.S. Environmental Protection Agency, EPA/625/R-96/010b.
- [6] ASTM [2015]. Standard test method for determination of volatile organic compounds in atmospheres (canister sampling methodology). West Conshohocken, PA: ASTM International, ASTM D5466 – 15.
- [7] ISO [2016]. General requirements for the competence of reference material producers. Geneva, Switzerland: International Organization for Standardization, ISO 17034.
- [8] Rossner A, Farant JP [2002]. Development of a flow controller for long-term sampling of gases and vapors using evacuated canisters. *Environ Sci Technol* 36:4912-4920.
- [9] NIOSH [1995]. Guidelines for air sampling and analytical method development and evaluation. By Kennedy ER, Fischbach TJ, Song R, Eller PM, Shulman SA. Cincinnati, OH: U.S. Department of Health and Human Services, Centers for Disease Control and Prevention, National Institute for Occupational Safety and Health, DHHS (NIOSH) Publication No. 95-117.
- [10] NIOSH [2018]. NIOSH 3900 Backup Data Report. By LeBouf RF, Feng A, Shulman SA. Cincinnati, OH: U.S. Department of Health and Human Services, Centers for Disease Control and Prevention, National Institute for Occupational Safety and Health, <https://www.cdc.gov/niosh/nmam/datadoc.html>.
- [11] Atkinson R, Arey J [2003]. Gas-phase tropospheric chemistry of biogenic volatile organic compounds: a review. *Atmos Environ* 37:S197-S219.
- [12] Forester C, Wells J [2009]. Yields of carbonyl products from gas-phase reactions of fragrance compounds with OH radical and ozone. *Environ Sci Technol* 43:3561-3568.

- [13] ASTM [2013]. Standard practice for the evaluating the performance of diffusive samplers. West Conshohocken, PA: ASTM International, ASTM D6246 – 08.
- [14] Rossner A, Wick DP [2005]. A field study to assess the long-term sampling feasibility of evacuated canisters and the development of a mathematical model to analyze potential sampling bias. *J Occ Environ Hyg* 2:474-480.
- [15] EPA [1999]. Compendium Method TO-14A: Determination of volatile organic compounds (VOCs) in ambient air using specially prepared canisters with subsequent analysis by gas chromatography. Cincinnati, OH, US Environmental Protection Agency, EPA/625/R-96/010b.
- [16] Code of Federal Regulations [2017]. Title 29 (Labor), Part 1910 (Occupational Safety and Health Standards); 29 CFR 1910.1000 Table Z-1; US Government Printing Office, Washington DC.
- [17] NIOSH [2010]. Pocket guide to chemical hazards. Cincinnati, OH: U.S. Department of Health and Human Services, Centers for Disease Control and Prevention, National Institute for Occupational Safety and Health, DHHS (NIOSH) Publication No. 2010-168c.

METHOD WRITTEN BY:

Ryan F LeBouf, PhD, CIH. CDC/NIOSH, Respiratory Health Division.

Disclaimer: Mention of any company or product does not constitute endorsement by the National Institute for Occupational Safety and Health (NIOSH), Centers for Disease Control and Prevention (CDC). In addition, citations to websites external to NIOSH do not constitute NIOSH endorsement of the sponsoring organizations or their programs or products. Furthermore, NIOSH is not responsible for the content of these websites. All web addresses referenced in this document were accessible as of the publication date.

TABLE 1. SYNONYMS, FORMULAE, MOLECULAR WEIGHTS AND PHYSICAL PROPERTIES

| IUPAC Name / Synonym | CAS # / RTECS | Empirical formula | Molecular Weight | Boiling Point (°C) | Vapor Pressure @ 20° C (mm Hg) | Vapor Pressure @ 20° C (kPa) |
|---|-------------------------|---|---------------------|--------------------------|---|---------------------------------------|
| ethanol / ethyl alcohol | 64-17-5/ KQ6300000 | C ₂ H ₆ O | 46.07 | 78.3 | 44 | 5.87 |
| 2-propanol / isopropyl alcohol | 67-63-0/ NT8050000 | C ₃ H ₈ O | 60.1 | 82.3 | 33 | 4.4 |
| acetone / 2- propanone | 67-64-1/ AL3150000 | C ₃ H ₆ O | 58.08 | 56.1 | 180 | 24 |
| 2,3-butanedione / diacetyl | 431-03-8/ EK2625000 | C ₄ H ₆ O ₂ | 86.09 | 88 | 52.2 | 6.96 |
| 2,3-pentanedione / acetyl propionyl | 600-14-6/ SA1850000 | C ₅ H ₈ O ₂ | 100.12 | 110- 112 | 21.4 | 2.85 |
| 2,3-hexanedione / acetyl butyryl | 3848-24-6 | C ₆ H ₁₀ O ₂ | 114.14 | 128 | 10 | 1.33 |
| dichloromethane / methylene chloride | 75-09-2/ PA8050000 | CH ₂ Cl ₂ | 84.93 | 40 | 350 | 46.7 |
| trichloromethane / chloroform | 67-66-3 | CHCl ₃ | 119.38 | 61.2 | 160 | 21.3 |
| hexane / n-hexane | 110-54-3/ MN9275000 | C ₆ H ₁₄ | 86.18 | 68.7 | 124 | 16.5 |
| benzene / benzol | 71-43-2/ CY1400000 | C ₆ H ₆ | 78.11 | 80.1 | 75 | 10 |
| toluene / methylbenzene | 108-88-3/ XS5250000 | C ₇ H ₈ | 92.14 | 110.6 | 22 | 2.93 |
| ethylbenzene / phenylethane | 100-41-4/ DA0700000 | C ₈ H ₁₀ | 106.17 | 136.2 | 7 | 0.93 |
| <i>o</i> -xylene / 1,2- dimethylbenzene | 95-47-6/ ZE2450000 | C ₈ H ₁₀ | 106.17 | 144.5 | 7 | 0.93 |
| <i>m</i> -xylene / 1,3- dimethylbenzene | 108-38-3/ ZE2275000 | C ₈ H ₁₀ | 106.17 | 139.1 | 9 | 1.2 |
| <i>p</i> -xylene / 1,4- dimethylbenzene | 106-42-3/ ZE2625000 | C ₈ H ₁₀ | 106.17 | 138.2 | 9 | 1.2 |
| methyl-2-methyl- 2-propenoate / methyl methacrylate | 80-62-6/ OZ5075000 | C ₅ H ₈ O ₂ | 100.12 | 100.5 | 29 | 3.87 |
| 4,6,6- trimethylbicyclo[3. 1.1]hept-3-ene / α - pinene / 2-pinene | 80-56-8/ DT7000000 | C ₁₀ H ₁₆ | 136.23 | 156.2 | 4.75 (25° C) | 0.63 |
| (4R)-1-methyl-4- prop-1-en-2- ylcyclohexene / <i>d</i> - limonene / <i>p</i> - mentha-1,8-diene, ("R") | 5989-27-5/ OS8100000 | C ₁₀ H ₁₆ | 136.23 | 178 | 1.43 | 0.19 |

TABLE 2. CHARACTERISTIC MASSES (M/Z) USED FOR QUANTITATION

| Substance | Primary Ion | Secondary Ion |
|---|-------------|---------------|
| ethanol | 45 | 46, 43 |
| 2-propanol | 45 | 43 |
| acetone | 43 | 58 |
| 2,3-butanedione | 86 | 43 |
| 2,3-pentanedione | 100 | 57, 43 |
| 2,3-hexanedione | 71 | 43, 114 |
| dichloromethane | 84 | 49, 86 |
| trichloromethane | 83 | 85, 47 |
| hexane | 57 | 41, 43 |
| benzene | 78 | 77, 52 |
| toluene | 91 | 92 |
| ethylbenzene | 91 | 106 |
| <i>o</i> -xylene | 91 | 106, 105 |
| <i>m,p</i> -xylene | 91 | 106, 105 |
| methyl methacrylate | 69 | 41, 100 |
| α -pinene | 93 | 91, 92 |
| <i>d</i> -limonene | 68 | 93, 67 |
| bromochloromethane ^A | 130 | 49, 93 |
| 1,4-difluorobenzene ^A | 114 | 63, 88 |
| chlorobenzene-d ⁵ ^A | 117 | 82, 119 |

^Ainternal standards

TABLE 3. EXPOSURE LIMITS (PPM) [16,17]

| Substance | OSHA TWA | OSHA Peak | NIOSH TWA | NIOSH STEL | mg/m ³ per ppm |
|---------------------|----------|-----------|------------------|--------------------|---------------------------|
| ethanol | 1000 | - | 1000 | - | 1.89 |
| 2-propanol | 400 | - | 400 | 500 | 2.46 |
| acetone | 1000 | - | 250 | - | 2.38 |
| 2,3-butanedione | - | - | 0.005 | 0.025 | 3.52 |
| 2,3-pentanedione | - | - | 0.0093 | 0.031 | 4.09 |
| 2,3-hexanedione | - | - | - | - | 4.67 |
| dichloromethane | 25 | 125 | N/A ^A | (ca ^B) | 3.47 |
| trichloromethane | - | 50 | - | 2 (60 min) | 4.88 |
| hexane | 500 | - | 50 | - | 3.53 |
| benzene | 1 | 5 | 0.1 (ca) | 1 (ca) | 3.19 |
| toluene | 200 | 500 | 100 | 150 | 3.77 |
| ethylbenzene | 100 | - | 100 | 125 | 4.34 |
| <i>o</i> -xylene | 100 | - | 100 | 150 | 4.34 |
| <i>m</i> -xylene | 100 | - | 100 | 150 | 4.34 |
| <i>p</i> -xylene | 100 | - | 100 | 150 | 4.34 |
| methyl methacrylate | 100 | - | 100 | - | 4.09 |
| α -pinene | - | - | - | - | 5.57 |
| <i>d</i> -limonene | - | - | - | - | 5.57 |

^AN/A = not applicable^Bca = carcinogen

TABLE 4A. RANGE, OVERALL BIAS, PRECISION AND ACCURACY FOR PPB LEVELS [4, 10]

| Substance | Range of generated samples | Overall Bias (%) | Overall Precision (S_{RT}) | Overall Accuracy (%) | 58 day Stability (%) |
|---------------------|----------------------------|------------------|--------------------------------|----------------------|----------------------|
| ethanol | 1.3 - 9.9 | -9.3 | 0.058 | ±22.2 | -0.5 (30 days) |
| 2-propanol | 1.3 - 10.0 | -12.3 | 0.098 | ±28.9 | 7.8 (30 days) |
| acetone | 1.3 - 10.0 | -3.2 | 0.064 | ±18.6 | 3.1 (30 days) |
| 2,3-butanedione | 21.5 - 381 | 2.2 | 0.032 | ±8.5 | 4.1 |
| 2,3-pentanedione | 20.8 - 377 | 4.8 | 0.048 | ±14.2 | 2.7 |
| 2,3-hexanedione | 20.4 - 368 | -6.0 | 0.061 | ±19.4 | -2.9 |
| dichloromethane | 1.3 - 9.8 | 2.9 | 0.017 | ±7.1 | 0.22 |
| trichloromethane | 1.3 - 9.8 | -0.3 | 0.020* | ±16.5* | 3.1 |
| hexane | 1.3 - 9.9 | -0.1 | 0.020 | ±5.5 | 3.6 |
| benzene | 1.3 - 9.8 | -3.0 | 0.022 | ±8.3 | 3.6 |
| toluene | 1.3 - 9.9 | -4.0 | 0.020 | ±8.6 | 1.6 |
| ethylbenzene | 1.3 - 9.9 | -4.4 | 0.020 | ±9.1 | -0.6 |
| <i>o</i> -xylene | 1.3 - 9.8 | -6.0 | 0.027 | ±12.3 | -3.5 |
| <i>m,p</i> -xylene | 1.3 - 9.8 | -6.7 | 0.025 | ±12.6 | -8.1 |
| methyl methacrylate | 1.3 - 9.9 | -10.2 | 0.066 | ±24.9 | 1.5 |
| α -pinene | 1.3 - 9.8 | -4.7 | 0.028 | ±11.4 | -3.3 |
| <i>d</i> -limonene | 1.3 - 9.8 | -4.6 | 0.069 | ±21.1 | -1.9 |

*worst-case precision estimate since failed Bartlett's test of homogeneity of variance across concentrations

S_{RT} = pooled precision as relative standard deviation across multiple concentration levels

Overall Accuracy=upper confidence limit on accuracy, A_{95}

Stability (%) = ((Concentration at storage day)/(Concentration at day 0)-1)*100%

TABLE 4B. RANGE, OVERALL BIAS, PRECISION AND ACCURACY FOR PPM-LEVELS [4]

| Substance | Range of generated samples | Overall Bias (%) | Overall Precision (S _{IT}) | Overall Accuracy (%) | 30 day Stability (%) |
|---------------------|----------------------------|------------------|--------------------------------------|----------------------|----------------------|
| ethanol | 0.81 - 1.8 | 9.4 | 0.028 | ±17.0 | -9.2 |
| 2-propanol | 0.82 - 1.8 | 8.9 | 0.027 | ±16.1 | -2.9 |
| acetone | 0.82 - 1.8 | 8.7 | 0.019 | ±13.8 | -1.6 |
| dichloromethane | 0.79 - 1.8 | 3.0 | 0.041* | ±17.8* | -4.7 |
| trichloromethane | 0.80 - 1.8 | 5.7 | 0.012 | ±8.9 | -1.9 |
| hexane | 0.81 - 1.8 | 6.1 | 0.012 | ±9.4 | 0.1 |
| benzene | 0.80 - 1.8 | 6.3 | 0.011 | ±9.3 | 7.3 |
| toluene | 0.81 - 1.8 | 5.5 | 0.015 | ±9.3 | 6.4 |
| ethylbenzene | 0.81 - 1.8 | 4.7 | 0.017 | ±9.2 | 0.8 |
| <i>o</i> -xylene | 0.80 - 1.8 | 5.4 | 0.019 | ±10.3 | -0.3 |
| <i>m,p</i> -xylene | 0.80 - 1.8 | 3.9 | 0.019 | ±8.8 | -2.1 |
| methyl methacrylate | 0.81 - 1.8 | 5.7 | 0.016* | ±15.6* | 1.4 |
| α -pinene | 0.81 - 1.8 | 6.7 | 0.022 | ±12.5 | 0.1 (21 days) |
| <i>d</i> -limonene | 0.80 - 1.8 | 13.1 | 0.039 | ±24.0 | -0.03 (21 days) |

*worst-case precision estimate since failed Bartlett's test of homogeneity of variance across concentrations

S_{IT} = pooled precision as relative standard deviation across multiple concentration levels

Overall Accuracy=upper confidence limit on accuracy, A₉₅

Stability (%) = ((Concentration at storage day)/(Concentration at day 0)-1)*100%

TABLE 5A. LIMITS OF DETECTION (LOD), MEASUREMENT RANGE, AND PRECISION FOR PPB-LEVELS [4, 10]

| Substance | LOD (ppb) | Range (ppb) | Precision (RMSE ^A) | Linearity R ² |
|---------------------|-----------|-------------|--------------------------------|--------------------------|
| ethanol | 0.4 | 0.25 – 21.4 | 0.272 | 0.999 |
| 2-propanol | 0.5 | 0.27 – 22.0 | 0.077 | 0.998 |
| acetone | 0.4 | 0.27 – 20.6 | 0.080 | 0.999 |
| 2,3-butanedione* | 0.3 | 0.26 – 21.0 | 0.033 | 0.999 |
| 2,3-pentanedione* | 0.2 | 0.24 – 18.4 | 0.148 | 0.999 |
| 2,3-hexanedione* | 0.4 | 0.24 – 18.0 | 0.238 | 0.999 |
| dichloromethane | 0.2 | 0.26 – 20.8 | 0.049 | 0.999 |
| trichloromethane | 0.1 | 0.27 – 21.6 | 0.044 | 0.999 |
| hexane | 0.2 | 0.27 – 21.8 | 0.030 | 0.999 |
| benzene | 0.2 | 0.27 – 21.6 | 0.032 | 0.999 |
| toluene | 0.3 | 0.27 – 21.4 | 0.023 | 0.999 |
| ethylbenzene | 0.3 | 0.26 – 21.0 | 0.019 | 0.999 |
| <i>o</i> -xylene | 0.3 | 0.26 – 21.0 | 0.019 | 0.999 |
| <i>m,p</i> -xylene | 0.4 | 0.27 – 22.0 | 0.015 | 0.999 |
| methyl methacrylate | 0.5 | 0.25 – 20.4 | 0.035 | 0.999 |
| α -pinene | 0.5 | 0.26 – 21.0 | 0.019 | 0.999 |
| <i>d</i> -limonene | 0.8 | 0.26 – 20.8 | 0.136 | 0.999 |

*Selected ion monitoring mode used to improve detection limits

^ARMSE= root mean square error

TABLE 5B. LIMITS OF DETECTION (LOD), MEASUREMENT RANGE, AND PRECISION FOR PPM-LEVELS [4]

| Substance | LOD (ppm) | Range (ppm) | Precision (SEE^A) | Linearity R² |
|-----------------------------------|------------------|--------------------|------------------------------------|--------------------------------|
| ethanol | 0.2 | 0.07 - 1.9 | 0.058 | 0.998 |
| 2-propanol | 0.2 | 0.07 - 2.0 | 0.066 | 0.998 |
| acetone | 0.3 | 0.08 - 2.0 | 0.071 | 0.998 |
| dichloromethane | 0.4 | 0.15 - 1.9 | 0.099 | 0.999 |
| trichloromethane | 0.3 | 0.11 - 1.9 | 0.093 | 0.999 |
| hexane | 0.2 | 0.11 - 2.0 | 0.072 | 0.999 |
| benzene | 0.2 | 0.11 - 1.9 | 0.064 | 0.999 |
| toluene | 0.3 | 0.11 - 1.9 | 0.101 | 0.998 |
| ethylbenzene | 0.3 | 0.11 - 1.9 | 0.108 | 0.998 |
| o-xylene | 0.1 | 0.11 - 1.3 | 0.031 | 0.998 |
| m,p-xylene | 0.3 | 0.11 - 1.9 | 0.110 | 0.998 |
| methyl methacrylate | 0.2 | 0.11 - 1.9 | 0.089 | 0.998 |
| α-pinene | 0.3 | 0.11 - 1.9 | 0.116 | 0.999 |
| d-limonene | 0.4 | 0.11 - 1.9 | 0.156 | 0.999 |

^ASEE = standard error of estimate from regression curve



HYDROQUINONE

5004

HOC₆H₄OH

MW: 110.11

CAS: 123-31-9

RTECS: MX3500000

METHOD: 5004, Issue 3

EVALUATION: FULL

Issue 1: 15 February 1984

Issue 3: 26 February 2016

OSHA: 2 mg/m³
NIOSH: C 2 mg/m³/15 min

PROPERTIES: solid; MP 170 °C; BP 285 °C @ 730 mm;
 VP 0.0024 Pa (1.8 x 10⁻⁵ mm Hg; 0.11 mg/m³) @
 25 °C

SYNONYMS: 1,4-benzenediol; hydroquinol; quinol; 1,4-dihydroxybenzene

| SAMPLING | | MEASUREMENT | |
|--|---|--|--|
| SAMPLER: | FILTER (0.8-µm cellulose ester membrane) | TECHNIQUE: | HPLC, UV DETECTION |
| FLOW RATE: | 1 - 4 L/min | ANALYTE: | hydroquinone |
| VOL-MIN: | 30 L @ 2 mg/m ³ | EXTRACTION: | 1% acetic acid, 10 mL |
| -MAX: | 180 L | INJECTION | |
| FIELD | | VOLUME: | 100 µL |
| TREATMENT: | transfer filter immediately to jar with 10 mL 1% acetic acid | MOBILE | |
| SHIPMENT: | ship sample solutions | PHASE: | 1% acetic acid in H ₂ O; 1 mL/min |
| SAMPLE | | COLUMN: | 25 cm x 4.6-mm ID C18/USP L1 column; ambient temperature, 400 to 600 psi (2800-4100 kPa) |
| STABILITY: | at least 7 days @ 25 °C | DETECTOR: | UV @ 290 nm |
| BLANKS: | 2 to 10 field blanks per set | CALIBRATION: | solutions of hydroquinone in 1% aqueous acetic acid |
| ACCURACY | | RANGE: | 0.06 to 0.8 mg per sample [2] |
| RANGE | | ESTIMATED LOD: | 0.01 mg per sample [3] |
| STUDIED: | 0.8 to 4 mg/m ³ [1] (90-L samples) | PRECISION (\bar{S}_r): | 0.030 [1] |
| BIAS: | 4.4% | | |
| OVERALL | | | |
| PRECISION ($\hat{S}_{r,T}$): | 0.061 | | |
| ACCURACY: | ± 15.0% | | |

APPLICABILITY: The working range is 0.7 to 8 mg/m³ for a 90-L air sample or 2 to 25 mg/m³ for a 30-L air sample. This method can be used when significant concentrations of hydroquinone vapor are not present.

INTERFERENCES: None known. Hydroquinone is unstable on the collection media and must be stabilized immediately after collection by dissolution in 1% acetic acid.

OTHER METHODS: This is Method S57 [2] in a revised format. The method also appears in a NIOSH recommended standard [4].

REAGENTS:

1. Hydroquinone, reagent grade.
2. Distilled water.
3. Acetic acid, glacial.
4. Acetic acid, 1%. Dilute 10 mL acetic acid to 1 L with distilled water.
NOTE: This solution is needed at the sampling site for field treatment of samples.
5. Calibration stock solution, 3.6 mg/mL. Dissolve 0.0900 g hydroquinone in 25 mL 1% acetic acid. Prepare fresh daily, in duplicate.

EQUIPMENT:

1. Sampler: 37-mm cassette containing 0.8- μ m cellulose ester membrane filter and cellulose backup pad.
2. Personal sampling pump, 1 to 4 L/min, with flexible connecting tubing.
3. High pressure liquid chromatograph with UV detector at 290 nm, integrator and column (page 5004-1).
4. Jars, 60-mL, ointment, low form, with PTFE film gaskets and screw caps.
5. Syringe, 100- μ L, or autosampler for sample injection.
6. Microliter syringes for standard preparation.
7. Volumetric flasks, 10- and 25-mL, and 1-L.

SPECIAL PRECAUTIONS: None

SAMPLING:

1. Calibrate each personal sampling pump with a representative sampler in line.
2. Sample at an accurately known flow rate between 1 and 4 L/min for a total sample size of 30 to 180 L.
NOTE: This method will collect hydroquinone aerosol only. The equilibrium vapor pressure is equivalent to 0.11 mg/m³ at 25 °C and may be a significant factor at elevated temperatures.
3. Immediately after sampling, transfer the filter (do not include backup pad) with tweezers to a 60-mL ointment jar. Add 10 mL 1% acetic acid. Process field blanks similarly.
4. Ship the filters in the ointment jars.

SAMPLE PREPARATION:

5. Transfer the sample solution from the ointment jar to a 25-mL volumetric flask.
6. Rinse the ointment jar twice with 5 mL 1% acetic acid. Add the washings to the volumetric flask. Make up to volume with 1% acetic acid.

CALIBRATION AND QUALITY CONTROL:

7. Calibrate daily with at least six working standards over the range 0.01 to 0.8 mg hydroquinone per sample.
 - a. Add known amounts of calibration stock solution to 1% acetic acid in 25-mL volumetric flasks and dilute to the mark.
 - b. Analyze together with samples and blanks (steps 9 and 10).
 - c. Prepare calibration graph (peak area vs. mg hydroquinone).
 - d. Prepare recovery graph (recovery vs. mg hydroquinone).
8. Check recovery with at least three spiked media blanks per sample set.
 - a. Add aliquot of calibration stock solution with a microliter syringe directly to a representative filter. Transfer filter to 60-mL ointment jar, add 10 mL 1% acetic acid, and allow to stand overnight.
 - b. Prepare and analyze together with working standards (steps 5, 6, 9 and 10).
 - c. Calculate recovery [(mg recovered - mg blank)/mg added].

MEASUREMENT:

9. Set HPLC to conditions given on page 5004-1. Inject 100- μ L sample aliquot.

10. Measure peak area. Retention time is ca. 5.2 min under these conditions.

CALCULATIONS:

11. Determine the mass, mg (corrected for recovery) of hydroquinone, found in the sample (W) and in the average media blank (B).
12. Calculate concentration of hydroquinone, C, in the air volume sampled, V (L):

$$C = \frac{(W - B) \times 10^3}{V}, \text{ mg/m}^3$$

EVALUATION OF METHOD:

Method S57 [2] was issued on November 26, 1976, and validated over the range 0.8 to 4 mg/m³ at 20 °C and 762 mm Hg using 90-L air samples [1,5]. Overall precision, \hat{S}_{rT} , was 0.061 with average recovery 105%, representing a non-significant bias. The atmospheres were generated by atomization of an aqueous solution of hydroquinone into dry air; aerosol concentrations were independently verified by direct UV spectrophotometry on filter samples. Average collection efficiency was 100% at 4 mg/m³. No loss of hydroquinone was seen from filters spiked with 720 µg hydroquinone, and then used to sample 180 L clean air, indicating the hydroquinone vapor pressure is not significant at these conditions. At elevated temperature, however, contribution from vapor may be significant. Storage studies were conducted by storing exposed filters in 1% acetic acid at ambient temperature for seven days. No change in hydroquinone concentration was seen.

REFERENCES:

- [1] NIOSH [1976]. Backup data report No. S57. In: Ten NIOSH analytical methods, set 2. Unpublished. Available as Order No. PB 271-464, from NTIS, Springfield, VA.
- [2] NIOSH [1977]. Hydroquinone: Method S57. In: Taylor DG, ed. NIOSH manual of analytical methods. 2nd ed. (vol 2) Cincinnati, OH: U.S. Department of Health, Education, and Welfare, Center for Disease Control, National Institute for Occupational Safety and Health, DHEW (NIOSH) Publication No. 77-157-B.
- [3] A.D. Little, Inc. [1983]. User check. NIOSH Sequence #4121Q. Unpublished.
- [4] NIOSH [1978]. Criteria for a recommended standard-occupational exposure to hydroquinone. Cincinnati, OH: U.S. Department of Health, Education, and Welfare, Center for Disease Control, National Institute for Occupational Safety and Health, DHEW (NIOSH) Publication No. 78-155.
- [5] NIOSH [1980]. NIOSH research report-development and validation of methods for sampling and analysis of workplace toxic substances. Cincinnati, OH: U.S. Department of Health and Human Services, Centers for Disease Control, National Institute for Occupational Safety and Health, DHHS (NIOSH) Publication No. 80-133.

METHOD REVISED BY:

Jerome Smith, Ph.D., NIOSH; S57 originally validated under NIOSH Contract 210-76-0123.

Disclaimer: Mention of any company or product does not constitute endorsement by NIOSH. In addition, citations to websites external to NIOSH do not constitute NIOSH endorsement of the sponsoring organizations or their programs or products. Furthermore, NIOSH is not responsible for the content of these websites. All web addresses referenced in this document were accessible as of the publication date.

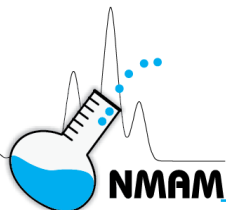

THIRAM

5005



MW: 240.43

CAS: 137-26-8

RTECS: JO1400000

METHOD: 5005, Issue 3

EVALUATION: FULL

Issue 1: 15 February 1984

Issue 3: 15 March 2016

OSHA: 5 mg/m³
NIOSH: 5 mg/m³; Group I Pesticide

PROPERTIES: white crystalline powder; d 1.29 g/mL;
 MP 155 °C; VP not significant

SYNONYMS: bis(dimethylthiocarbamoyl)disulfide; tetramethylthiuram disulfide; tetramethylthioperoxydicarbonic diamide

| SAMPLING | | MEASUREMENT | |
|---|---|--|---|
| SAMPLER: | FILTER (1- μm PTFE membrane) | TECHNIQUE: | HPLC, UV DETECTION |
| FLOW RATE: | 1 to 4 L/min | ANALYTE: | Thiram |
| VOL-MIN: | 10 L | EXTRACTION: | (filter) 10 mL CH ₃ CN, 30 min; (cassette top) 10 mL CH ₃ CN rinse |
| -MAX: | 400 L | INJECTION VOLUME: | 5 μL |
| SHIPMENT: | routine | MOBILE PHASE: | 60% acetonitrile/40% water, 1 mL/min |
| SAMPLE STABILITY: | 7 days at 25 °C | COLUMN: | C18 (30 cm x 3.9-mm-ID stainless steel); ambient temperature |
| BLANKS: | 2 to 10 field blanks per set | DETECTOR: | UV @ 254 nm, 1-cm cell |
| BULK SAMPLES: | desirable; 1 to 5g | CALIBRATION: | standard solutions of Thiram in acetonitrile |
| ACCURACY | | RANGE: | 0.1 to 3 mg per sample [1] |
| RANGE STUDIED: | 3 to 12 mg/m ³ [1] (240-L samples) | ESTIMATED LOD: | 0.005 mg per sample [1] |
| BIAS: | -0.18% | PRECISION (\bar{S}_r): | 0.012 [1] |
| OVERALL PRECISION (\hat{S}_{rT}): | 0.055 [1] | | |
| ACCURACY: | $\pm 10.67\%$ | | |

APPLICABILITY: The working range is 0.5 to 15 mg/m³ for a 200-L air sample. NIOSH researchers have used this method at facilities that use Thiram as an insecticide.

INTERFERENCES: None known.

OTHER METHODS: This is Method S256 [2] in a revised format. An earlier spectrophotometric method, P&CAM 228 [3], has not been revised because of excessive analytical variability [4].

REAGENTS:

1. Acetonitrile, HPLC grade.*
2. Water, distilled, deionized.
3. Thiram, reagent grade.*
4. Air or nitrogen, compressed, for drying syringes.
5. Calibration stock solution, 0.75 mg/mL.
Dissolve an accurately weighed 7.5 mg Thiram in acetonitrile and dilute to 10 mL.
Prepare fresh daily in duplicate.

*See SPECIAL PRECAUTIONS.

EQUIPMENT:

1. Sampler: 1- μ m polytetrafluoroethylene (PTFE) membrane filter, 37-mm diameter, two-piece polystyrene cassette filter holder with backup pad, sealed with tape or a shrinkable band.
2. Personal sampling pump, 1 to 4 L/min, with flexible connecting tubing.
3. Liquid chromatograph, UV detector at 254 nm, integrator and column (page 5005-1).
4. 13 mm x 5 μ m PTFE filters and stainless steel filter holder to protect the LC column.
5. Vials, 20-mL, glass, PTFE-lined screw caps.
6. Syringe, 1-mL, with luer lock style fitting.
7. Pipets, 10-mL, with pipet bulb.
8. Tweezers.
9. Volumetric flasks, 10-mL.

SPECIAL PRECAUTIONS: Acetonitrile is toxic and flammable; work with it only in a hood. Thiram is an irritant of skin and mucous membranes, a skin sensitizer, and suspected teratogen [5].

SAMPLING:

1. Calibrate each personal sampling pump with a representative sampler in line.
2. Sample at 1 to 4 L/min for a total sample size of 10 to 400 L. Do not exceed 2 mg total dust loading on the filter.
3. Collect a bulk sample (1 to 5 g) in a glass vial with PTFE-lined cap; ship separately from filters.

SAMPLE PREPARATION:

4. Remove filter from cassette with tweezers and place in 20-mL vial.
5. Add 10 mL acetonitrile. Cap the vial.
6. Rinse the inside top of cassette with 10 mL acetonitrile into a 20-mL vial. Cap the vial.
7. Agitate samples during the 30-min desorption period.

CALIBRATION AND QUALITY CONTROL:

8. Calibrate daily with at least six working standards over the range 0.005 to 3 mg Thiram per sample.
 - a. Add known amounts of calibration stock solution to acetonitrile in 10-mL volumetric flasks and dilute to the mark.
 - b. Analyze together with samples and blanks (steps 9 and 10).
 - c. Prepare calibration graph (peak area vs. mg Thiram).

MEASUREMENT:

9. Set liquid chromatograph to conditions on page 5005-1. Inject 10- μ L sample aliquot. Rinse and dry syringe between injections.
10. Measure peak area.

CALCULATIONS:

11. Read the mass, mg, of Thiram found in the sample filter (W_f) and top rinse (W_t) and in the average media blank (B) from calibration graph.
12. Calculate the concentration of Thiram, C (mg/m^3), in the air volume sampled, V (L):

$$C = \frac{(W_f + W_t - B) \cdot 10^3}{V}, \text{mg}/\text{m}^3$$

EVALUATION OF METHOD:

Method S256 was issued on June 8, 1979 [2], and validated by collecting 18 samples (six each at 0.5, 1 and 2 times the OSHA standard) from dynamically-generated test atmospheres using Thiram 65 (65% Thiram; Mayer Chemical Co.), as well as a set of six samples which was stored at room temperature for seven days to establish stability [1,4]. The stored sample results were within 2.1% of samples analyzed after one day, indicating adequate storage stability for seven days. Eighteen more samples were spiked directly (six each at 0.5, 1 and 2 times the OSHA standard). The pooled relative standard deviation for these three sets of samples was found to be 0.012. The average recovery for all three levels was 99.8%; therefore, there is no bias for this method. The pooled relative standard deviation for the three sets of samples collected from test atmospheres was 0.022. Test atmospheres at 12 mg/m^3 Thiram were sampled with PTFE filters followed by bubblers containing acetonitrile; no detectable Thiram ($\text{LOD} = 0.005 \text{ mg}$) was found in the bubblers indicating that vapor pressure of Thiram was insignificant.

REFERENCES:

- [1] Stanford Research Institute [1979]. Backup Data Report: Method S256. Menlo Park, CA: Stanford Research Institute. NIOSH contract 210-76-0123. Available as order no. PB-81-244634 from NTIS.
- [2] NIOSH [1979]. Thiram in air: Method S256. In: Taylor DG, ed. NIOSH manual of analytical methods. 2nd. ed. (Vol 5). Cincinnati, OH: U.S. Department of Health, Education, and Welfare, Center for Disease Control, National Institute for Occupational Safety and Health, DHEW (NIOSH) 79-141.
- [3] NIOSH [1976]. Thiram in air: Method P&CAM 228. In: Taylor DG, ed. NIOSH manual of analytical methods. 2nd ed. (Vol 1). Cincinnati, OH: U.S. Department of Health, Education, and Welfare, Center for Disease Control, National Institute for Occupational Safety and Health, DHEW (NIOSH) Publication No. 77-157-A.
- [4] IIT Research Institute [1976]. Failure Report: Method S256. Chicago, IL: IIT Research Institute. NIOSH contract no. 99-74-45. Unpublished.
- [5] NIOSH [1978] NIOSH criteria for a recommended standard: occupational exposure during manufacture and formulation of pesticides, Cincinnati, OH: U.S. Department of Health, Education, and Welfare, Center for Disease Control, National Institute for Occupational Safety and Health, DHEW (NIOSH) Publication No. 78-174.
- [6] NIOSH [1980]. NIOSH research report – development and validation of methods for sampling and analysis of workplace toxic substances. Cincinnati, OH: U.S. Department of Health and Human Services, Centers for Disease Control, National Institute for Occupational Safety and Health, DHHS (NIOSH) Publication No. 80-133.

METHOD REVISED BY:

Yvonne T. Gagnon, NIOSH; S256 originally validated under NIOSH Contract 210-76-0123.

Disclaimer: Mention of any company or product does not constitute endorsement by NIOSH. In addition, citations to websites external to NIOSH do not constitute NIOSH endorsement of the sponsoring organizations or their programs or products. Furthermore, NIOSH is not responsible for the content of these websites. All web addresses referenced in this document were accessible as of the publication date.



ROTENONE

5007

C₂₃H₂₂O₆

MW: 394.43

CAS: 83-79-4

RTECS: DJ2800000

METHOD: 5007, Issue 3

EVALUATION: FULL

Issue 1: 15 February 1984

Issue 3: 26 February 2016

OSHA: 5 mg/m³

PROPERTIES: solid, MP 163 °C or 181 °C; BP 220 °C @ 0.5 mm

NIOSH: 5 mg/m³; Group II Pesticide

Hg; d ca. 1 g/cm³; VP not significant

SYNONYMS: tubatoxin; cube

| SAMPLING | | MEASUREMENT | |
|--|--|--|--|
| SAMPLER: | FILTER (1-mm PTFE membrane) | TECHNIQUE: | HPLC; UV DETECTION |
| FLOW RATE: | 1 - 4 L/min | ANALYTE: | Rotenone |
| VOL-MIN: | 8 L | EXTRACTION: | 4 mL acetonitrile; 30 min |
| -MAX: | 400 L | INJECTION VOLUME: | 10 µL |
| SHIPMENT: | routine | MOBILE PHASE: | 60% methanol/40% water, 2 mL/min |
| SAMPLE STABILITY: | at least 7 days @ 25 °C in dark | DETECTOR: | UV @ 290 nm; 0.1A full-scale; 1-cm cell |
| BLANKS: | 2 to 10 field blanks per set | COLUMN: | C18 (30 cm x 3.9-mm ID stainless steel); ambient temperature |
| BULK SAMPLE: | desirable; 1g | CALIBRATION: | solutions of Rotenone in acetonitrile |
| ACCURACY | | RANGE: | 0.04 to 1 mg per sample |
| RANGE STUDIED: | 1 to 11 mg/m ³ [1] (100-L sample) | ESTIMATED LOD: | 4 µg per sample [1, 2] |
| BIAS: | -0.6% | PRECISION (\bar{S}_r): | 0.024 [1] |
| OVERALL PRECISION ($\bar{S}_{r,T}$): | 0.079 | | |
| ACCURACY: | ± 13.5% | | |

APPLICABILITY: The working range is 0.4 to 10 mg/m³ for a 100-L air sample and the method is applicable to commercial formulations.

INTERFERENCES: None known. Rotenone, a naturally occurring insecticide, is adequately separated by HPLC from other compounds (e.g., sumatrol, α-toxicarol, deguelin, elliptone, malaccol, and tephrosin [3]) present in commercial cube root extracts [4]. Rotenone is sensitive to photodecomposition.

OTHER METHODS: This is Method S300 [2] in a revised format.

REAGENTS:

1. Acetonitrile, HPLC grade.*
2. Methanol, HPLC grade.
3. Rotenone, 97% purity.
4. Water, distilled, HPLC grade.
5. Calibration stock solution, 3 mg/mL.
Dissolve 0.075 g Rotenone in 25 mL acetonitrile. Prepare fresh daily in duplicate.
6. Recovery stock solution, 50 mg/mL.
Dissolve 0.500 g Rotenone in acetone. Dilute to 10 mL. Prepare fresh daily.

*See SPECIAL PRECAUTIONS.

EQUIPMENT:

1. Sampler: 37-mm, two-piece cassette containing 1- μ m PTFE membrane filter with backup pad.
NOTE: Use an opaque cassette or otherwise shield the filter from light to minimize photodecomposition of Rotenone during and after sampling.
2. Personal sampling pump, 1 to 4 L/min, with flexible connecting tubing.
3. HPLC, UV detector, integrator and column (page 5007-1).
4. Jars, ointment, 60-mL, with PTFE-lined caps.
5. Vials, 4-mL, with PTFE-lined caps.
6. Syringes, 5-mL.
7. Filtration device, 13-mm with 1- μ m PTFE filters, or PTFE syringe filters.
8. Volumetrics, 10- and 25-mL.
9. Syringes, microliter, for sample injection and standard preparation.
10. Pipet, 4-mL, with pipet bulb.

SPECIAL PRECAUTIONS: Avoid breathing acetonitrile vapors; may cause skin irritation.

SAMPLING:

1. Calibrate each personal sampling pump with a representative sampler in line.
2. Sample at an accurately known flow rate between 1 and 4 L/min for a total sample size of 8 to 400 L. Do not exceed 2 mg total dust loading on the filter.
3. Collect a bulk sample (1 g) in a glass vial with PTFE-lined cap; ship separately from filters.

SAMPLE PREPARATION:

4. Open filter cassette; transfer filter to ointment jar.
5. Add 4.0 mL acetonitrile; gently swirl for 30 min.
6. Filter each sample using a 5-mL syringe with PTFE syringe filter or filtration device. Deliver filtrate to a 4-mL vial.

CALIBRATION AND QUALITY CONTROL:

7. Prepare at least six working standards daily in the range 0.01 to 1 mg Rotenone per sample.
 - a. Add known amounts of calibration stock solution to acetonitrile in 10-mL volumetric flasks and dilute to the mark.
 - b. Analyze together with samples and blanks (steps 9 and 10).
 - c. Prepare calibration graph (peak area vs. mg Rotenone).

8. Check recovery (R) with at least three spiked media blanks per sample set in the calibration range (step 7).
 - a. Add aliquots of recovery stock solution to blank filters with a microliter syringe. Air dry.
 - b. Analyze together with working standards (steps 4 through 6, 9 and 10).
 - c. Calculate recovery [(mg recovered - mg blank)/mg added].
 - d. Prepare recovery graph (R vs. mg Rotenone).

MEASUREMENT:

9. Set HPLC system according to manufacturer's recommendations and to conditions given on page 5007-1. Inject 10- μ L sample.
NOTE: If peak area is above linear range of calibration graph, dilute, reanalyze, and apply appropriate dilution factor in calculations.
10. Measure peak area.

CALCULATIONS:

11. Read the mass, mg (corrected for recovery) of Rotenone found on the filter (W) and average media blank (B) from the calibration graph.
12. Calculate the concentration, C (mg/m³), of Rotenone in the air volume sampled, V (L):

$$C = \frac{(W - B) \times 10^3}{V}, \text{ mg/m}^3$$

EVALUATION OF METHOD:

Method S300 [2] was issued on May 11, 1979, and validated over the range 1.16 to 11.1 mg/m³ at 25°C and 760 mm, using 100-L samples [1, 5]. Overall precision, \hat{S}_{RT} , was 0.079 with average recovery 100.4%, representing a non-significant bias. The concentration of Rotenone (generated by Wright dust feeder using Ortho Rotenone Dust [1%; Chevron Chemical Co.] enriched to 10% Rotenone with analytical grade Rotenone [Aldrich Chemical Co.]) was independently verified by collection in dioxane and HPLC analysis. Recovery was 0.98 in the range 250 to 1000 μ g Rotenone per sample. Collection efficiency of the PTFE filter was found to be greater than 99% and no detectable Rotenone (LOD = 4 μ g) was found on Chromosorb 102 tubes placed behind the PTFE filters at 11.8 mg/m³. No loss was seen from spiked filters stored in the dark at room temperature for seven days.

REFERENCES:

- [1] NIOSH. Backup data report. Unpublished. Available as Order No. PB 82-114729 from NTIS, Springfield, VA.
- [2] NIOSH [1979]. Rotenone: Method S300. In: Taylor DG, ed. NIOSH manual of analytical methods. 2nd ed. (Vol 5). Cincinnati, OH: U.S. Department of Health, Education, and Welfare, Center for Disease Control, National Institute for Occupational Safety and Health, DHEW (NIOSH) Publication No. 79-141.
- [3] Gunther FA, Blinn RG [1975]. Analysis of insecticides and acaricides. NY: Interscience, pp 419-420.
- [4] Bushway RJ, Engdahl BS, Colvin BM, Hanks AR [1975]. Separation of rotenoids and the determination of rotenone in pesticide formulations by high-performance liquid chromatography. J Assoc Off Anal Chem 58(5):965-970.

- [5] NIOSH [1980]. NIOSH research report-development and validation of methods for sampling and analysis of workplace toxic substances. Cincinnati, OH: U.S. Department of Health and Human Services, Centers for Disease Control, National Institute for Occupational Safety and Health, DHHS (NIOSH) Publication No. 80-133.

METHOD REVISED BY:

Jerome Smith, Ph.D., NIOSH; S300 originally validated under NIOSH Contract 210-76-0123.

Disclaimer: Mention of any company or product does not constitute endorsement by NIOSH. In addition, citations to websites external to NIOSH do not constitute NIOSH endorsement of the sponsoring organizations or their programs or products. Furthermore, NIOSH is not responsible for the content of these websites. All web addresses referenced in this document were accessible as of the publication date.

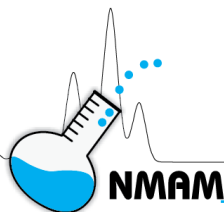

PYRETHRUM

5008

$C_{20}H_{28}O_3$ to $C_{22}H_{30}O_5$
(Table 1)

MW: 316.4-372.4 CAS: 8003-34-7
(active constituents)

RTECS: UR4200000

METHOD: 5008, Issue 3

EVALUATION: FULL

Issue 1: 15 May 1985

Issue 3: 25 February 2016

OSHA: 5 mg/m³
NIOSH: 5 mg/m³; Group II pesticide

PROPERTIES: viscous brown resin or solid;
VP not significant

SYNONYMS: Active constituents include pyrethrin I and II, jasmolin I and II, and cinerin I and II.

| SAMPLING | | MEASUREMENT | |
|--|--|---|---|
| SAMPLER: | FILTER (glass fiber, 37 mm) | TECHNIQUE: | HPLC, UV DETECTION |
| FLOW RATE: | 1 - 4 L/min | ANALYTE: | six active constituents of pyrethrum |
| VOL-MIN: | 20 | EXTRACTION: | 10 mL acetonitrile; stand 30 min |
| -MAX: | 400 L | INJECTION | |
| SHIPMENT: | routine; ship bulk sample separately | VOLUME: | 25 µL |
| SAMPLE STABILITY: | at least 1 week @ 25 °C [1] | COLUMN: | C18, reverse phase, 10-µm packing, 25 to 30 cm |
| BLANKS: | 2 to 10 field blanks per set | MOBILE PHASE: | 85% acetonitrile/15% water, isocratic, 1.0 mL/min, room temperature, 2000 kPa (400 psi) |
| ACCURACY | | DETECTOR: | UV absorption @ 225 nm |
| RANGE STUDIED: | 1.4 to 8.5 mg/m ³ [1] (132-L samples) | CALIBRATION: | solutions of pyrethrum in acetonitrile |
| BIAS: | -4.5% | RANGE: | 0.1 to 1.8 mg/sample |
| OVERALL PRECISION ($\hat{S}_{r,T}$): | 0.070 [1] | ESTIMATED LOD: | 0.01 mg/sample |
| ACCURACY: | ± 13.8% | PRECISION ($\bar{S}_{r,}$): | 0.040 [1] |

APPLICABILITY: The working range is 0.5 to 10 mg/m³ for a 200-L air sample.

INTERFERENCES: Specific interferences have not been studied. Mass spectrometry or gas-liquid chromatography with electron-capture detection may be needed for confirmation [1].

OTHER METHODS: This method is S298 [2] in a revised format. For bulk samples, gas-liquid chromatography with electron-capture detection has been recommended [3]. A modified HPLC method (C8 column, programmed methanol/water or acetonitrile, isocratic) has been used [4].

REAGENTS:

1. Pyrethrum*, analytical standard solution (commercially available).
NOTE: Store away from direct light. Active constituents of pyrethrum oxidize in air and photo-decompose.
2. Acetonitrile, HPLC grade.*
3. Water, HPLC grade.
4. Isopropanol.
5. Calibration stock solution,* 60 mg/mL, in isopropanol.

*See SPECIAL PRECAUTIONS.

EQUIPMENT:

1. Sampler: 37-mm glass fiber filter and cellulose backup pad in filter holder held together with tape or shrinkable band.
2. Personal sampling pump, 1 to 4 L/min, with flexible connecting tubing.
3. High pressure liquid chromatograph with UV absorption detector at 225 nm, integrator and column (page 5008-1).
4. Ointment jars, 2-oz, squat form, with polytetrafluoroethylene (PTFE)-lined screw caps.
5. Tweezers.
6. Pipet, TD, 10-mL, with pipet bulb.
7. Volumetric flasks, 10-mL.
8. Syringe, 10-mL, with syringe filter.
9. Syringes or pipets, 5- to 100- μ L.

SPECIAL PRECAUTIONS: *p*-Chlorophenol is toxic by skin absorption, inhalation, or ingestion. It also is a strong irritant to tissue and is combustible with a flash point of 121 °C.

SAMPLING:

1. Calibrate each personal sampling pump with a representative sampler in line.
2. Sample at an accurately known flow rate between 1 and 4 L/min for a total sample size of 20 to 400 L.

SAMPLE PREPARATION:

3. Transfer the filter carefully to an ointment jar using tweezers.
4. Add 10.0 mL acetonitrile. Seal and gently swirl the jar to wet the filter. Let stand 30 min with occasional swirling.
5. Filter the sample solution through a syringe filter.

CALIBRATION AND QUALITY CONTROL:

6. Calibrate daily with at least six working standards over the range 0.01 to 1.8 mg pyrethrum per sample.
 - a. Add known amounts of calibration stock solution, or a dilution thereof, to acetonitrile in 10-mL volumetric flasks and dilute to the mark.
 - b. Analyze together with the samples and blanks (steps 9, 10 through 11).
 - c. Prepare calibration graph (peak area vs. mg pyrethrum/10 mL).
7. Determine recovery (R) at least once for each batch of filters used for sampling in the range of the samples. Prepare three filters at each of five levels plus three media blanks.
 - a. Deposit a known amount of calibration stock solution, or a dilution thereof, onto the filters. Allow filters to air-dry.
 - b. Store samples overnight in ointment jars.
 - c. Prepare (steps 4 and 5) and analyze together with working standards (steps 9 through 11).
 - d. Prepare a graph of R vs. mg pyrethrum recovered.
8. Analyze three quality control blind spikes and three analyst spikes to ensure that the calibration graph and R graph are in control.

MEASUREMENT:

9. Set HPLC system according to manufacturer's recommendations and to conditions on page 5008-1.
10. Inject sample aliquot using syringe, fixed volume sample loop, or autosampler.
11. Measure peak area.

NOTE: Pyrethrum is a mixture of at least six components which elute in two major peaks ($t_r = 5$ to 7 min under these conditions). The minor peaks have been shown by mass spectrometry not to be pyrethrums. The components may be separated by gas chromatography [1,4].

CALCULATIONS:

12. Determine the mass, mg (corrected for R) of pyrethrum found in the sample (W) and in the average media blank (B) from the calibration graph.
13. Calculate concentration, C, of pyrethrum in the air volume sampled, V (L):

$$C = \frac{(W - B) \times 10^3}{V}, \text{ mg/m}^3$$

EVALUATION OF METHOD:

Method S298 [2] was issued on August 3, 1979, and validated over the range 1.4 to 8.5 mg/m³ using atmospheres generated from Premium Pyroicide 175 (McLaughlin Gormley King Co.) [1]. Standards and collected filter samples were analyzed by GC/MS. Lab testing was done with spiked filters and atmospheres dynamically generated by atomization of a hydrocarbon solution; verified by PTFE filter/isooctane bubbler analyzed by gas chromatography with electron capture detector (absence of pyrethrum in the bubbler was established by mass spectrometry). Samples containing 0.7 mg pyrethrum collected from a test atmosphere were stable for seven days at ambient conditions (average recovery = 98.2%). Collection efficiency equal 99.7% for 120-L samples collected at 1 L/min at 9 mg/m³. Precision and accuracy are given on page 5008-1.

REFERENCES:

- [1] NIOSH [1979]. Backup Data Report: Method S298. Unpublished.
- [2] NIOSH [1980]. Pyrethrum: Method S298. In: Taylor DG, ed. NIOSH manual of analytical methods. 2nd ed. (Vol 6) Cincinnati, OH: U.S. Department of Health and Human Services, Centers for Disease Control, National Institute for Occupational Safety and Health, DHHS (NIOSH) Publication No. 80-125.
- [3] Association of Official Analytical Chemists (AOAC) [1982]. Changes in official methods of analysis. *J Assoc Off Anal Chem* 65: 455-456.
- [4] Hultquist A, Izumi RM [1982]. NIOSH sequence reports 3481-J and 4151-J. Salt Lake City, UT: Utah Biomedical Test Laboratory. Unpublished.
- [5] NIOSH [1981]. Occupational health guidelines for chemical hazards. Cincinnati, OH: U.S. Department of Health and Human Services, Centers for Disease Control, National Institute for Occupational Safety and Health, DHHS (NIOSH) Publication No. 81-123.

METHOD REVISED BY:

James E. Arnold, NIOSH

Table 1. Active constituents of Pyrethrum.

| Compound | Formula | M.W. | CAS # |
|-----------------|--|-------------|--------------|
| Cinerin I | C ₂₀ H ₂₈ O ₃ | 316.44 | 25402-06-6 |
| Cinerin II | C ₂₁ H ₂₈ O ₅ | 260.45 | 121-20-0 |
| Jasmolin I | C ₂₁ H ₃₀ O ₃ | 330.47 | 4466-14-2 |
| Jasmolin II | C ₂₂ H ₃₀ O ₅ | 374.48 | 1172-63-0 |
| Pyrethrin I | C ₂₁ H ₂₈ O ₃ | 328.45 | 121-21-1 |
| Pyrethrin II | C ₂₂ H ₂₈ O ₅ | 372.46 | 121-29-9 |

Disclaimer: Mention of any company or product does not constitute endorsement by NIOSH. In addition, citations to websites external to NIOSH do not constitute NIOSH endorsement of the sponsoring organizations or their programs or products. Furthermore, NIOSH is not responsible for the content of these websites. All web addresses referenced in this document were accessible as of the publication date.

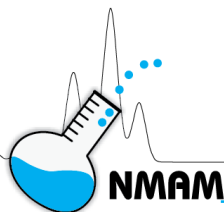

BENZOYL PEROXIDE

5009



MW: 242.22

CAS: 94-36-0

RTECS: DM85750000

METHOD: 5009, Issue 3

EVALUATION: FULL

Issue 1: 15 February 1984

Issue 3: 26 February 2016

OSHA: 5 mg/m³

NIOSH: 5 mg/m³

PROPERTIES: solid; MP 103 °C; d 1.334 g/mL @ 25 °C; VP not significant; auto ignition temperature 80 °C

SYNONYMS: dibenzoyl peroxide, benzoyl superoxide

| SAMPLING | | MEASUREMENT | |
|--|--|--|---|
| SAMPLER: | FILTER (0.8-µm cellulose ester membrane) | TECHNIQUE: | HPLC, UV DETECTION |
| FLOW RATE: | 1 - 3 L/min | ANALYTE: | benzoyl peroxide |
| VOL-MIN: | 40 L @ 5 mg/m ³ | EXTRACTION: | ethyl ether, 10 mL |
| -MAX: | 400 L | PRESSURE-COLUMN: | 9000 KPa (1300 psi) |
| SHIPMENT: | refrigerated | MOBILE PHASE: | 70/30 methanol/water; 1.6 mL/min |
| SAMPLE STABILITY: | 9% loss from filter after 1 week @ 25 °C | COLUMN: | 250 mm x 3 mm-ID stainless steel; spherical silica particles with 5% bonded coating of octadecyl groups, US Pharmacopeia (USP) L1 |
| BLANKS: | 2 to 10 field blanks per set | DETECTOR: | UV photometer @ 254 nm |
| ACCURACY | | CALIBRATION: | benzoyl peroxide in ethyl ether |
| RANGE STUDIED: | 3 to 9 mg/m ³ [1]; (90-L samples) | RANGE: | 0.2 to 1.7 mg per sample [1] |
| BIAS: | -0.52% | ESTIMATED LOD: | 0.01 mg per sample [2] |
| OVERALL PRECISION ($\hat{S}_{r,T}$): | 0.06 [1] | PRECISION (\hat{S}_r): | 0.024 [1] |
| ACCURACY: | ± 11.82% | | |

APPLICABILITY: The working range is 2 to 19 mg/m³ for a 90-L air sample.

INTERFERENCES: None identified

OTHER METHODS: This is Method S253 [3] in a revised format. A non-specific gravimetric method and a non-specific colorimetric method appear in the criteria document [4].

REAGENTS:

1. Benzoyl peroxide, 99% pure.*
2. Ethyl ether, purified, without stabilizer.*
3. Methanol, distilled in glass.
4. Water, deionized and distilled.
5. Calibration stock solution, 10 mg/mL.
Dissolve 250 mg benzoyl peroxide in ethyl ether and dilute to 25 mL. Stable at least one week at 4 °C.

*See SPECIAL PRECAUTIONS.

EQUIPMENT:

1. Sampler: cellulose ester membrane filter, 0.8- μ m pore size, 37-mm diameter, with backup pad in cassette filter holder.
2. Personal sampling pump, 1 to 3 L/min, with flexible connecting tubing.
3. Refrigerant, water solution, sealed, refreezable, reusable.
4. Vials, 20-mL, polytetrafluoroethylene (PTFE)-lined caps.
5. High performance liquid chromatograph, 254-nm UV detector, sample injection valve with a 20- μ L external sample loop, syringe filter, integrator and column (page 5009-1) or autosampler.
6. Tweezers.
7. Microliter syringes, 10- and 100- μ L.
8. Volumetric flasks, 10- and 25-mL, assorted sizes.
9. Pipet, 10-mL, with pipet bulb.

SPECIAL PRECAUTIONS: Benzoyl peroxide is a flammable solid and may explode when heated; it will attack some plastics, rubber, and coatings [4]. Ethyl ether is highly flammable and forms explosive peroxides on exposure to air.

SAMPLING:

1. Calibrate each personal sampling pump with a representative sampler in line.
2. Sample at an accurately known flow rate between 1 and 3 L/min for a total sample size of 40 to 400 L. Do not exceed 2 mg particulate loading on the filter.
3. Ship samples in an insulated container with bagged refrigerant.

SAMPLE PREPARATION:

4. Immediately upon receipt at laboratory, refrigerate the samples.
5. As soon as possible after receipt, transfer each filter to a clean vial with tweezers.
6. Pipet 10 mL ethyl ether into each vial; screw on cap. Swirl to mix.

CALIBRATION AND QUALITY CONTROL:

7. Calibrate daily with at least six working standards covering the range 0.01 to 1.7 mg per sample.
 - a. Add calibration stock solution with a microliter syringe to ethyl ether in a 10-mL volumetric flask and dilute to the mark.
 - b. Analyze together with samples, blanks and control samples (steps 10 through 12).
 - c. Prepare calibration graph of peak area vs. mass (mg) of benzoyl peroxide per sample.
8. Determine recovery of benzoyl peroxide from filters at least once for each lot of samplers in the calibration range (step 7). Prepare three filters at each of five levels plus media blanks.
 - a. Add aliquot of calibration stock solution with a microliter syringe directly onto a media blank filter in a vial.
 - b. Prepare and analyze together with working standards (steps 5, 6 and 10 through 12).
 - c. Prepare a graph of recovery vs. mg benzoyl peroxide recovered.

- Analyze three quality control blind spikes and three analyst spikes to ensure that the calibration graph and recovery graph are in control.

MEASUREMENT:

- Set high performance liquid chromatograph according to manufacturer's recommendations and to conditions given on page 5009-1.
- Flush sample loop thoroughly with sample (0.1 mL) and inject sample or autosampler.
- Measure peak area.

CALCULATIONS:

- Read mass, mg (corrected for recovery), of benzoyl peroxide found on sample filters, W (mg), and on average blank filters, B (mg), from calibration graph.
- Calculate concentration, C (mg/m^3), of benzoyl peroxide in the air volume sampled, V (L):

$$C = \frac{(W - B) \times 10^3}{V}, \text{mg}/\text{m}^3$$

EVALUATION OF METHOD

Method S253 was issued on January 21, 1977 [3], and validated over the range 3.1 to 19.1 mg/m^3 at 26 °C and 764 mm Hg, using 90-L samples [1, 5]. The collection efficiency of the filter was determined to be 1.00, since no benzoyl peroxide was detected on a backup filter mounted directly behind the front filter. Storage stability studies on the filters held in the filter cassettes indicated a 9.3% decrease in the amount of benzoyl peroxide recovered after one week. Benzoyl peroxide was stable in ethyl ether at room temperature for at least one week. Overall precision, \hat{S}_{rT} , was 0.060. Recovery was 0.97 in the range 0.225 to 0.900 mg per sample for 18 spiked samples.

REFERENCES:

- NIOSH [1976]. Backup data report: S253 for Benzoyl Peroxide. In: Ten NIOSH analytical methods (Set 2). Available as order No. PB 271-464 from NTIS. Unpublished.
- Wade R [1980]. Memorandum: UBTL analytical laboratory report for benzoyl peroxide, Sequence #2182-J. Salt Lake City, UT: Utah Biomedical Test Laboratory. Unpublished.
- NIOSH [1978]. Benzoyl peroxide: Method S253. In: NIOSH manual of analytical methods. 2nd ed. (Vol 4). Cincinnati, OH: U.S. Department of Health, Education, and Welfare, Center for Disease Control, National Institute for Occupational Safety and Health, DHEW (NIOSH) Publication No. 78-175.
- NIOSH [1977]. NIOSH criteria for a recommended standard: occupational exposure to benzoyl peroxide. Cincinnati, OH: U.S. Department of Health, Education, and Welfare, Center for Disease Control, National Institute for Occupational Safety and Health, DHEW (NIOSH) Publication No. 77-166.
- Gunderson EC, Anderson CC [1980]. Development and validation of methods for sampling and analysis of workplace toxic substances. Cincinnati, OH: U.S. Department of Health and Human Services, Centers for Disease Control, National Institute for Occupational Safety and Health, DHHS (NIOSH) Publication No. 80-133.

METHOD REVISED BY:

Charles Neumeister, NIOSH.

Disclaimer: Mention of any company or product does not constitute endorsement by NIOSH. In addition, citations to websites external to NIOSH do not constitute NIOSH endorsement of the sponsoring organizations or their programs or products. Furthermore, NIOSH is not responsible for the content of these websites. All web addresses referenced in this document were accessible as of the publication date.

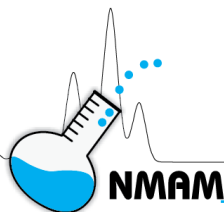

STRYCHNINE

5016

C₂₁H₂₂N₂O₂

MW: 334.42

CAS: 57-24-9

RTECS: WL2275000

METHOD: 5016, Issue 3

EVALUATION: FULL

Issue 1: 15 May 1985

Issue 3: 26 February 2016

OSHA: 0.15 mg/m³

PROPERTIES: solid; MP 268 °C; VP not significant

NIOSH: 0.15 mg/m³/10h; Group I Pesticide

SYNONYMS: strychnidin-10-one

| SAMPLING | | MEASUREMENT | |
|--|--|--|--|
| SAMPLER: | FILTER (glass fiber, 37-mm) | TECHNIQUE: | HPLC, UV DETECTION |
| FLOW RATE: | 1 - 3 L/min | ANALYTE: | strychnine |
| VOL-MIN: | 70 L @ 0.15 mg/m ³ | DESORPTION: | 5 mL mobile phase |
| -MAX: | 1000 L | INJECTION VOLUME: | 20 µL |
| SHIPMENT: | routine | MOBILE PHASE: | aqueous 1-heptane sulfonic acid + CH ₃ CN; pH 3.5; 1 mL/min @ ambient temperature |
| SAMPLE STABILITY: | at least 7 days @ 25 °C [1] | COLUMN: | 25 cm x 4.2-mm ID, packed with C18/US Pharmacopeia (USP) L1, 10-µm particle size |
| BLANKS: | 2 to 10 field blanks per set | DETECTOR: | UV absorption @ 254 nm |
| ACCURACY | | CALIBRATION: | solutions of strychnine in mobile phase |
| RANGE STUDIED: | 0.073 to 0.34 mg/m ³ [3] 180-L samples) | RANGE: | 10 to 70 µg per sample |
| BIAS: | 4.4% | ESTIMATED LOD: | 0.8 µg per sample [1,2] |
| OVERALL PRECISION ($\hat{S}_{r,T}$): | 0.059 [1] | PRECISION (\hat{S}_r): | 0.042 @ 13 to 62 µg per sample [1] |
| ACCURACY: | ± 14.6% | | |

APPLICABILITY: The working range is 0.05 to 10 mg/m³ for a 200-L air sample.

INTERFERENCES: None known

OTHER METHODS: This revises Method S302 [2].

REAGENTS:

1. Strychnine, 98%.*
2. Acetonitrile, chromatographic quality.
3. Water, chromatographic quality, distilled.
4. Acetonitrile:water, 1:1 (v/v). Mix equal volumes of acetonitrile and distilled water.
5. Acetic acid, glacial.*
6. Acetic acid, 0.01 N. Dilute 0.6 mL glacial acetic acid to 1 L with distilled water.
7. 1-Heptanesulfonic acid sodium salt, 95%.
8. Calibration stock solution, 1 mg/mL strychnine in 0.01 N acetic acid. Use an ultrasonic bath to aid dissolution.
9. Mobile phase: Dissolve 1.1014 g 1-heptanesulfonic acid sodium salt in 980 mL 1:1 acetonitrile:water. Adjust pH to 3.5 with glacial acetic acid. Dilute to 1 L with 1:1 acetonitrile:water. Filter through 0.45- μ m PTFE filter and refrigerate. Prepare fresh weekly and if cloudiness appears.

*See SPECIAL PRECAUTIONS.

EQUIPMENT:

1. Sampler: glass fiber filter, 37-mm diameter, in cassette filter holder.
2. Personal sampling pump, 1 to 3 L/min, with flexible connecting tubing.
3. HPLC, UV absorption detector at 254 nm, recorder, integrator and column (page 5016-1).
4. Syringe filter, polypropylene housing, nylon membrane, 0.2- μ m pore size.
5. Syringe, 20- μ L.
6. Micropipets or syringes, 10- to 100- μ L.
7. Jars, glass, squat-form ointment, with polytetrafluoroethylene (PTFE)-lined screw caps.
8. Volumetric flasks, glass, 10-mL.
9. Pipet, 5-mL delivery, with pipet bulb.
10. Tweezers.
11. Ultrasonic bath.

SPECIAL PRECAUTIONS: Strychnine is a potent convulsant. Use impervious clothing, gloves and face shields when handling it [3,4]. Avoid skin contact with acetic acid as it may cause severe burns.

SAMPLING:

1. Calibrate each personal sampling pump with a representative sampler in line.
2. Sample at an accurately known flow rate between 1 and 3 L/min for a total sample size of 70 to 1000 L.

SAMPLE PREPARATION:

3. Transfer the filter carefully using tweezers to an ointment jar.
4. Add 5.0 mL mobile phase. Seal and gently swirl the jar to wet the filter.
5. Filter the sample solution through a syringe filter.

CALIBRATION AND QUALITY CONTROL:

6. Calibrate daily with at least six working standards over the range 1 to 70 μ g strychnine per sample (0.2 to 14 μ g/mL).
 - a. Add known amounts of calibration stock solution to mobile phase in 10-mL volumetric flasks and dilute to the mark.
 - b. Analyze together with the samples and blanks (steps 9, 10, and 11).
 - c. Prepare calibration graph (peak area vs. μ g strychnine).
7. Determine recovery (R) at least once for each lot of filters used for sampling in the calibration range. Prepare three filters at each of five levels plus three media blanks.
 - a. Deposit a known amount of calibration stock solution onto the filter. Allow filters to air dry.
 - b. Store samples overnight in ointment jars.
 - c. Prepare for analysis (steps 3 through 5) and analyze together with working standards (steps 9 through 11).

- d. Prepare a graph of R vs. μg strychnine recovered.
8. Analyze three quality control blind spikes and three analyst spikes to ensure that the calibration graph and R graph are in control.

MEASUREMENT:

9. Set HPLC system according to manufacturer's recommendations and to the conditions given on page 5016-1.
10. Inject sample aliquot using syringe, fixed volume sample loop or autosampler.
11. Measure peak area.

CALCULATIONS:

12. Determine the mass, μg (corrected for R) of strychnine found in the sample (W) and in the average media blank (B) from the calibration graph.
13. Calculate concentration, C, of strychnine in the air volume sampled, V (L):

$$C = \frac{W - B}{V}, \text{mg}/\text{m}^3$$

EVALUATION OF METHOD:

Method S302 was issued on February 17, 1978 [2], and evaluated over the range 0.073 to 0.34 mg/m^3 using a 180-L sample [1,5]. Overall precision, $\hat{S}_{r,T}$, was 0.059 with an average recovery of 100.9%, representing a non-significant bias. The concentration of strychnine was independently verified by analysis of filter samples with a UV spectrophotometer at 254 nm. Recovery was 0.98 in the range of 13.5 to 54.1 μg per sample. Collection efficiency was determined to be at least 98.8% for 180-L sample at a concentration to be 0.15 $\mu\text{g}/\text{mL}$. Average recovery for one-day old samples was 105% vs. 98.8% for seven-day old samples stored at room temperature. Since the filter samples for the recovery and stability studies were prepared with strychnine acetate rather than the free base, the recovery of the free base and the stability of such samples is unknown.

REFERENCES:

- [1] NIOSH [1976]. Back-up data report for Strychnine. In: Ten NIOSH analytical methods. Available as order No. PB288-629 from NTIS. Unpublished.
- [2] NIOSH [1979] Strychnine: Method S302. In: Taylor, DG ed. 2nd ed. (Vol 5). NIOSH manual of analytical methods. Cincinnati, OH: U.S. Department of Health, Education, and Welfare, Center for Disease Control, National Institute for Occupational Safety and Health, DHEW (NIOSH) Publication No. 79-141.
- [3] NIOSH [1978]. NOSH criteria for a recommended standard: occupational exposure during the manufacture and formulation of pesticides. Cincinnati, OH: U.S. Department of Health, Education, and Welfare, Center for Disease Control, National Institute for Occupational Safety and Health, DHEW (NIOSH) Publication No. 78-174. Available as order No. PB81-227001 from NTIS.
- [4] NIOSH [1981]. Occupational health guidelines for chemical hazards. Cincinnati, OH: U.S. Department of Health and Human Services, Centers for Disease Control, National Institute for Occupational Safety and Health, DHHS (NIOSH) Publication No. 81-123.

- [5] NIOSH [1980]. Development and validation of methods for sampling and analysis of workplace and toxic substances. Cincinnati, OH: U.S. Department of Health and Human Services, Centers for Disease Control, National Institute for Occupational Safety and Health, DHHS (NIOSH) Publication No. 80-133.

METHOD REVISED BY:

M.J. Seymour, NIOSH

Disclaimer: Mention of any company or product does not constitute endorsement by NIOSH. In addition, citations to websites external to NIOSH do not constitute NIOSH endorsement of the sponsoring organizations or their programs or products. Furthermore, NIOSH is not responsible for the content of these websites. All web addresses referenced in this document were accessible as of the publication date.



ARSENIC, organo-

5022

| | | | |
|--|----------------|-------------------|----------------------|
| (1) CH ₃ AsO ₃ H ₂ | MW: (1) 139.96 | CAS: (1) 124-58-3 | RTECS: (1) PA1575000 |
| (2) (CH ₃) ₂ AsO ₂ H | (2) 137.99 | (2) 75-60-5 | (2) CH7525000 |
| (3) H ₂ NC ₆ H ₄ AsO ₃ H | (3) 217.07 | (3) 98-50-0 | (3) CF7875000 |

METHOD: 5022, Issue 3

EVALUATION: FULL

Issue 1: 15 May 1985

Issue 3: 3 March 2016

OSHA: 0.5 mg/m³ (as As)
NIOSH: None

PROPERTIES: (1) Solid; MP 161 °C
(2) Solid; MP 195 °C
(3) Solid; MP 232 °C

SYNONYMS: (1) Methylarsonic acid: methanearsonic acid. (2) Dimethylarsinic acid: cacodylic acid; hydroxydimethyl arsine oxide. (3) *p*-Aminophenyl arsonic acid: *p*-arsanilic acid; atoxylic acid.

| SAMPLING | | MEASUREMENT | |
|--|---|--|--|
| SAMPLER: | FILTER (1- μ m PTFE) | TECHNIQUE: | ION CHROMATOGRAPHY/HYDRIDE ATOMIC ABSORPTION |
| FLOW RATE: | 1 - 3 L/min | ANALYTE: | anions (IC); AsH ₃ (AAS) |
| VOL-MIN: | 50 L @ 0.1 mg/m ³ | EXTRACTION: | borate-carbonate buffer, 25 mL |
| -MAX: | 1000 L | ION CHROMATOGRAPHY: | |
| SHIPMENT: | routine | INJECTION | |
| SAMPLE STABILITY: | stable | LOOP VOLUME: | 0.8 mL |
| BLANKS: | 2 to 10 field blanks per set | COLUMNS: | two, 3 x 150-mm anion |
| | | ELUENT: | borate-carbonate buffer; 2.5 mL/min; 3450 kPa (500 psi); ambient temperature |
| | | AAS: | |
| | | QUARTZ | |
| | | FURNANCE: | 800 °C |
| | | WAVELENGTH: | 193.7 nm (no D ₂) |
| | | CALIBRATION: | organoarsenicals in water |
| | | RANGE: | 0.5 to 2 μ g As per sample |
| | | ESTIMATED LOD: | 0.2 μ g As per sample [1] |
| | | PRECISION (\bar{S}_r): | Table 1 |
| ACCURACY | | | |
| RANGE STUDIED: | 0.005 to 0.2 mg/m ³ [1,2] | | |
| BIAS: | none significant | | |
| OVERALL PRECISION ($\hat{S}_{r,T}$): | 0.047 @ 0.02 mg/m ³ [1]; 0.14 @ 0.005 mg/m ³ [1] | | |
| ACCURACY: | \pm 20% @ 0.02 mg/m ³ | | |

APPLICABILITY: The working range is 0.005 to 10 mg/m³ (as As) for a 100-L air sample. The method is designed to quantitate particulate organo-arsenic compounds.

INTERFERENCES: Inorganic arsenic (III) co-elutes with dimethylarsenic acid using Eluent A but the two may be separated with Eluent B. Other ions at high concentrations in the sample can interfere with the chromatographic separation of the arsenicals. As₂O₃ is not efficiently sampled by this sampler; for quantitation of that compound see Method 7901.

OTHER METHODS: This is P&CAM 320 in revised format [2]. Method 7200 measures total As by hydride/AAS. Method 7901 measures As₂O₃, which can exist as a vapor and aerosol.

REAGENTS:

1. Deionized water.
2. Hydrochloric acid, conc.
3. Eluent A (2.4 mM HCO₃⁻/1.9 mM CO₃²⁻/1.0 mM B₄O₇²⁻). Dissolve 0.8067 g NaHCO₃, 0.8055g Na₂CO₃, and 1.5257 g Na₂B₄O₇•10H₂O in 4 L deionized water.
4. Eluent B (5 mM B₄O₇²⁻). Dissolve 7.6284 g Na₂B₄O₇•10 H₂O in 4L deionized waster.
5. Potassium persulfate solution,* K₂S₂O₈, saturated in 15% (v/v) HCl.
6. Sodium borohydride, 1% NaBH₄ (w/v) in 0.2% KOH (w/v). Add 5 g NaBH₄ and 1 g KOH to deionized water; dilute to 500 mL. Prepare fresh weekly.
7. Stock standards, 1000 µg As/mL:
 - a. Methylarsonic acid.* Dissolve 0.9341 g CH₃AsO₃H₂, in deionized water; dilute to 500 mL.
 - b. Dimethylarsenic acid.* Dissolve 0.9210 g (CH₃)₂AsO₂H in deionized water; dilute to 500 mL.
 - c. *p*-Aminophenylarsonic acid.* Dissolve 1.4485 g *p*-H₂NC₆H₄AsO₃H₂ in 5 mL 1 N NaOH. Dilute to 500 mL with deionized water. Protect from light.
 - d. Arsenic trioxide.* Dissolve 0.6602 g As₂O₃ in 5 mL 1 N NaOH. Dilute to 500 mL with deionized water.
 - e. Arsenic pentoxide.* Dissolve 0.7669 g As₂O₅ in 5 mL 1 N NaOH. Dilute to 500 mL with deionized water.
8. Calibration stock solution, 1 µg/mL mixed analyte. Dilute 0.1 mL of each stock standard (REAGENTS, 7.) with Eluent A in a 100-mL volumetric flask. Prepare fresh daily.
9. Argon.

*See SPECIAL PRECAUTIONS.

EQUIPMENT:

1. Sampler: PTFE polyethylene-backed membrane filter, 1-µm pore size, 37-mm diameter with backup pad; in cassette filter holder.
2. Personal sampling pump, 1 to 3 L/min, with flexible connecting tubing.
3. Ion chromatograph with suppressor and detector bypassed. Route column effluent via PTFE tubing (0.3mm ID x 0.6mm OD) directly into arsine generator (Figure 1).
4. Syringes, plastic, 10-mL, with male luer lock style fittings.
5. Arsine generator: proportioning pump with flow-rated pump tubes and 1.5-mm ID x 3-mm OD manifold mixing coils, 5-turn and 20-turn, 1.5-mm ID x 3.5-mm OD glass "T" connectors; gas-liquid separator and expansion chamber (Figure 2); 1 m of 1/4" OD PTFE tubing; three PTFE 1/4" ID Swagelok fittings; and rotometer (100 to 900 mL/min).
6. Atomic absorption spectrophotometer (reciprocal linear UV dispersion 0.65 nm/mm); As electrodeless discharge lamp and power supply; and atomization cell (16-cm x 13-mm ID windowless quartz tube with 18-cm x 4-mm ID inlet tube fused in the center), wound with Nichrome wire (14 Ω/m, spaced 2 to 3 mm between turns and wrapped with heat resistant tape) (Figure 3). Temperature in the cell is measured by a thermocouple (800 °C). Mount the cell on top of a single-slot AAS burner head and align with burner alignment controls.
7. Beakers, 50-mL.**
8. Ultrasonic waterbath.
9. Volumetric flasks, 10-, 100- and 500-mL.**
10. Pipets, 25-µL and 0.1- to 1-mL.

**Soak all glassware in mild detergent, rinse with deionized water, 10% HNO₃, and deionized water.

SPECIAL PRECAUTIONS: Wear gloves, lab coat, and safety glasses while handling chemicals. All work should be performed in a fume hood. Potassium persulfate is a powerful oxidizing agent. Arsine gas is extremely toxic and can be fatal. The arsenic compounds used in the stock standards are poisonous [3].

SAMPLING:

1. Calibrate each personal sampling pump with a representative sampler in line.
2. Sample at an accurately known flow rate between 1 and 3 L/min for a total sample volume of 50 to 1000 L.
3. Cap the cassettes and pack securely for shipment.

SAMPLE PREPARATION:

4. For each sample, pipet 25 mL Eluent A into a clean 50-mL beaker.
5. Open the cassette, remove the PTFE filter with clean forceps, and transfer it to the beaker. Place the exposed side of the filter in contact with the solution. Cover beaker.
6. Agitate contents of the beaker for 30 min in an ultrasonic water bath. If the extracts will not be analyzed immediately, store at ca. 4 °C until measurement.

CALIBRATION AND QUALITY CONTROL:

7. Calibrate daily with at least six working standards over the range 0.2 to 2 µg As per sample (0.008 to 0.08 µg As/mL).
 - a. Add known amounts of calibration stock solution to Eluent A in 10-mL volumetric flasks and dilute to the mark.
 - b. Analyze together with the samples and blanks (steps 8 through 12).
 - c. Prepare calibration graph for each arsenic species (peak area or height vs. µg As).

MEASUREMENT:

8. Set the ion chromatograph to the conditions given on page 5022-1. Allow the columns to equilibrate with eluent >1 h before connecting effluent to the arsine generator.

NOTE: Eluent A allows the separation of methylarsonic acid (retention time (t_r) = 2 min), *p*-aminophenylarsonic acid (t_r = 4 min), and As(V) (t_r = 7.5 min); As(III) and dimethylarsenic acid (t_r = 1 min) are not resolved. If a signal is obtained at the approximate retention time of the latter two compounds, or if both compounds are known to be present in the sample, perform a second analysis using Eluent B (lower ionic strength). If either of the two compounds is known not to be present, Eluent A will effectively determine the remaining compounds. With Eluent B the other species have very long retention times and will accumulate on the column, tying up active resin sites. Therefore, flush the column with Eluent A after each 10 to 15 samples and reequilibrate with Eluent B before further analysis.

9. Connect the IC effluent to the arsine generator into which the following flow:

| | |
|--|------------|
| Saturated K ₂ S ₂ O ₈ solution: | 0.8 mL/min |
| NaBH ₄ solution: | 2.0 mL/min |
| Ar carrier gas: | 300 mL/min |

NOTE: The gaseous arsines formed in the arsine generator are first separated from liquid solution using the gas-liquid separator (Figure 2) and then transferred by argon carrier gas through PTFE tubing to the heated quartz furnace.

10. Set the AAS according to manufacturer's recommendations and to the conditions given on page 5022-1. Align the quartz cell in the optical path. Heat the quartz cell gradually to 800 °C using a variable transformer and thermocouple.
11. Using a syringe, inject a sample aliquot (ca. 2 to 3 mL) into the chromatograph, flushing the injection loop to avoid contamination from the previous injection. Rinse the syringe with deionized water and dry it between samples, or use disposable syringes.
12. Identify the component peaks. Measure peak height or area.

Calculations

13. From the calibration graphs, calculate the amount (μg) of arsenic for each species in the sample (W) and in the average media blank (B).
14. Calculate the arsenic concentrations, C , (mg/m^3) in the air volume sampled, V (L):

$$C = \frac{W - B}{V}, \text{mg}/\text{m}^3$$

EVALUATION OF METHOD:

The measurement precision obtained under the conditions recommended in this procedure is presented in Table 1 [1]. The overall precision of the method was tested using filters loaded in a dynamic aerosol generation/sampling system with particulates of the three organoarsenical compounds. The concentration levels tested for each species were 5, 10, and 20 $\mu\text{g As}/\text{m}^3$ of air. Depending on the concentration and species, the relative standard deviation ranged from 14.4% at the lowest level to 4.7% at the highest level.

The collection efficiency of the method for organoarsenicals in the range of 5 to 20 $\mu\text{g}/\text{m}^3$ using a 300-L sample was found to be >99%. The collection efficiency of the method for inorganic arsenic was not determined.

The accuracy of the overall method was determined by analyzing additional aerosol samples from each set using Neutron Activation (NAA) and X-ray Fluorescence (XRF) analyses. Since NAA and XRF techniques provide only the total elemental arsenic, the total arsenic obtained from the IC-AAS analysis was used for comparison. The accuracy ranged from 90 to 120% of the values obtained by NAA and XRF.

REFERENCES:

- [1] Colovos G, Hester N, Ricci GR, Shepard, LS. [1980]. Development of a method for the determination of organoarsenicals in air. NIOSH Contract #210-77-0134, NTIS No. PB83-180794.
- [2] NIOSH [1980]. Particulate arsenicals: Method P&CAM 320. In: Taylor, DG, ed. NIOSH manual of analytical methods, 2nd ed. Cincinnati, OH: U.S. Department of Health and Human Services, Centers for Disease Control, National Institute for Occupational Safety and Health, DHHS (NIOSH) Publication No. 80-125.
- [3] Budavari S, [1989]. Merck Index. 11th ed. Rahway, NJ: Merck & Co., Inc.

METHOD REVISED BY:

Mary Ellen Cassinelli, NIOSH;
P&CAM 320 originally developed under NIOSH Contract 210-77-0134.

TABLE 1. Sensitivity, detection limit and working range data for analysis of particulate arsenicals [1].

| Arсенical | Sensitivity (ng/mL/ 1% Abs) | Detection limit (as As) for 300 L sample volume (µg/m³) | Detection limit (as As) for solution (ng/mL) | Range* for 300 L sample volume (µg/m³) | Range* for solution (ng/mL) | Measurement precision (% \bar{S}_r) |
|-----------------------------------|-----------------------------|---|--|--|-----------------------------|--|
| Dimethylarsenic acid | 1.3 | 0.62 | 7 | 1.7-6.7 | 20-80 | 11.2 |
| Arsenic (III) | 2.1 | 0.71 | 8 | 1.7-6.7 | 20-80 | 11.2 |
| Methylarsonic acid | 2.1 | 0.72 | 9 | 1.7-6.7 | 20-80 | 8.1 |
| <i>p</i> -Aminophenylarsonic acid | 6.3 | 0.64 | 8 | 1.7-6.7 | 20-80 | 6.0 |
| Arsenic (V) | 13.0 | 0.46 | 6 | 1.7-6.7 | 20-80 | 10.8 |

*The upper limit of the range can be increased by using higher concentration standards which are injected via loops of smaller volume. Although not tested with air samples, the useful range can be extended from 5 µg/m³ down to 1.7 µg/m³ based upon the measurement range.

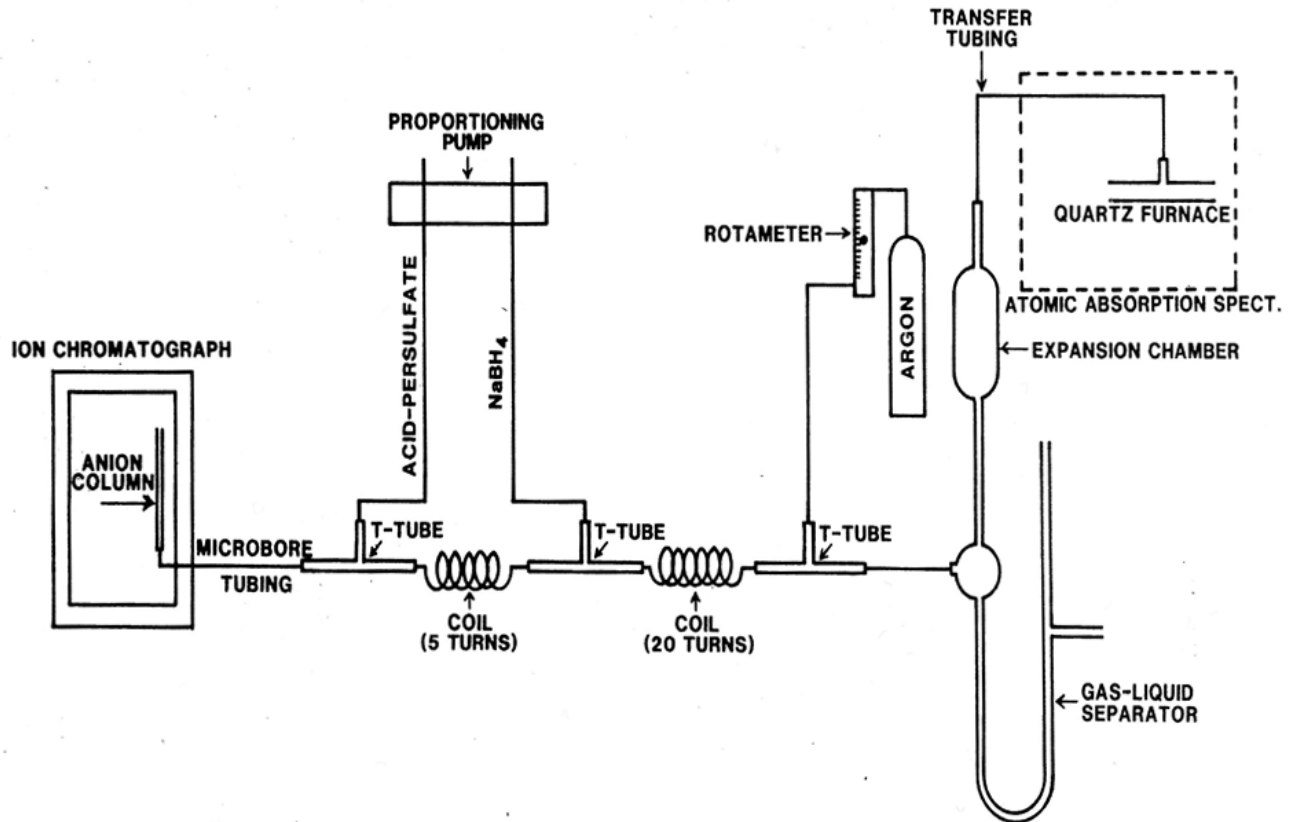

FIGURE 1. IC/AAS Analytical System.

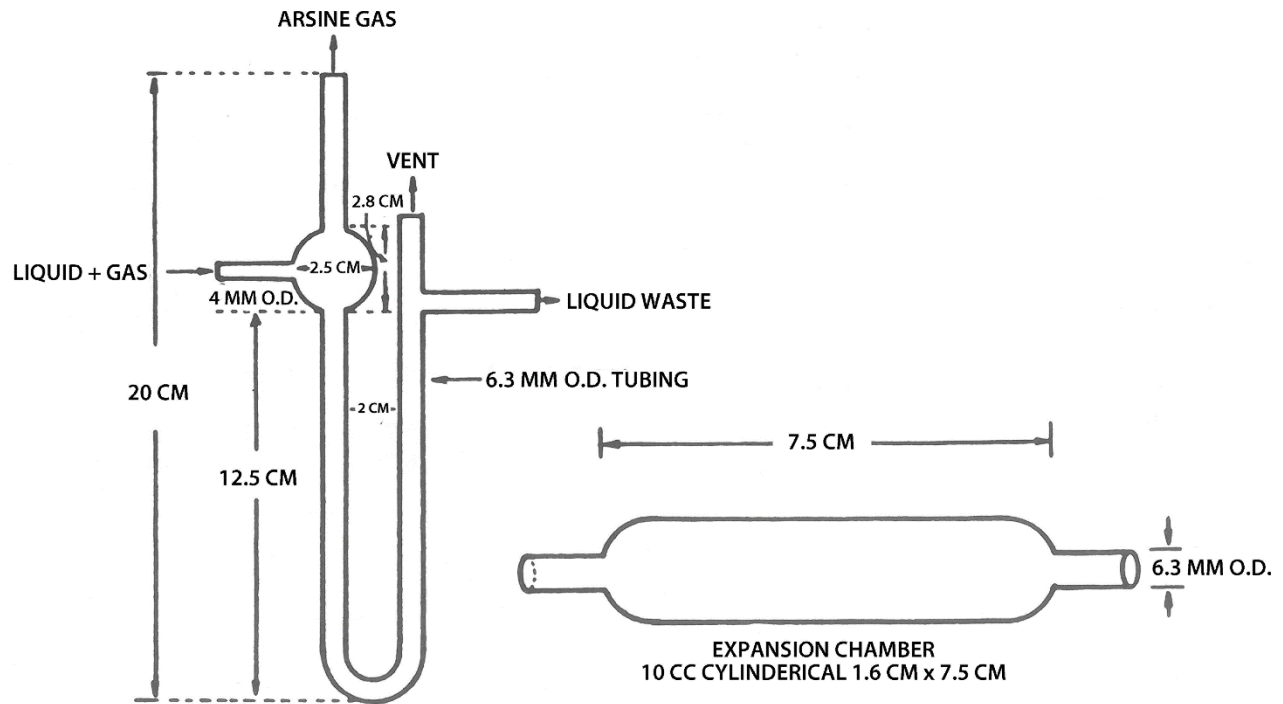

FIGURE 2. Gas-Liquid Separator and Expansion Chamber.

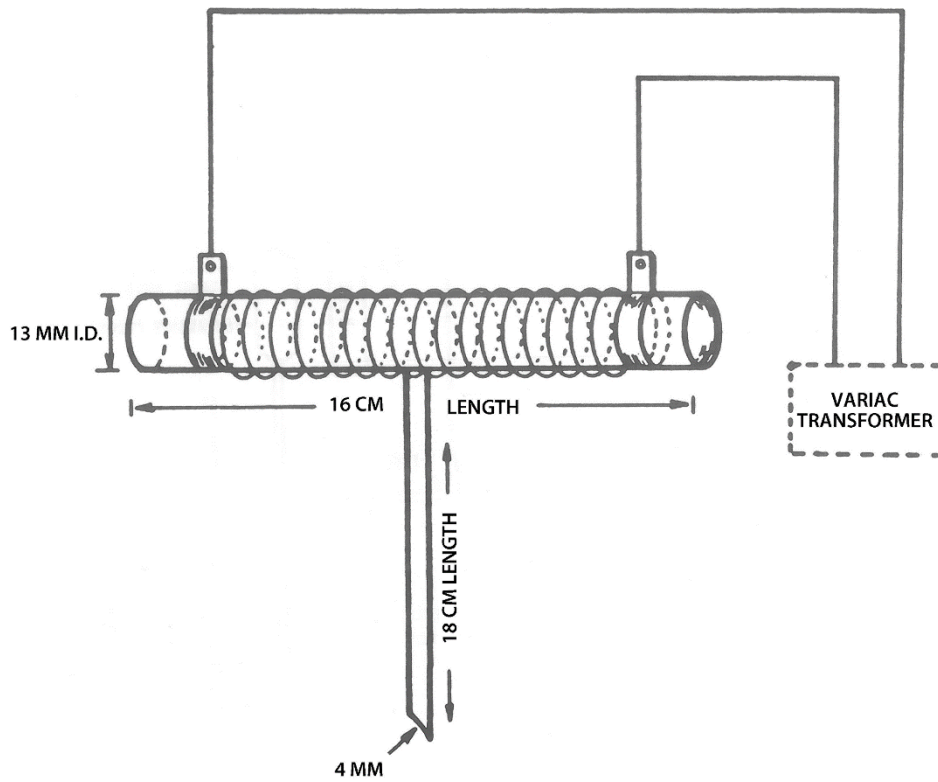

FIGURE 3. Quartz Furnace Atomization Cell.

Disclaimer: Mention of any company or product does not constitute endorsement by NIOSH. In addition, citations to websites external to NIOSH do not constitute NIOSH endorsement of the sponsoring organizations or their programs or products. Furthermore, NIOSH is not responsible for the content of these websites. All web addresses referenced in this document were accessible as of the publication date.



p-NITROANILINE

5033

H₂NC₆H₄NO

MW: 138.14

CAS: 100-01-6

RTECS: BY7000000

METHOD: 5033, Issue 2

EVALUATION: FULL

Issue 1: 15 August 1994

Issue 2: 29 February 2016

OSHA: 6 mg/m³ (skin)
NIOSH: 3 mg/m³ (skin)

PROPERTIES: yellow crystals; MP 146 °C; BP 332 °C; VP 0.02 Pa (1.5 x 10⁻⁴ mm Hg) @ 20 °C

SYNONYMS: 4-nitrobenzenamine, *p*-aminonitrobenzene, *p*-nitrophenylamine

| SAMPLING | | MEASUREMENT | |
|--|--|--|--|
| SAMPLER: | FILTER (0.8 µm mixed cellulose ester membrane) | TECHNIQUE: | HPLC, UV DETECTION |
| FLOW RATE: | 1 - 3 L/min | ANALYTE: | <i>p</i> -nitroaniline |
| VOL-MIN: | 16 L @ 6 mg/m ³ | EXTRACTION: | 5 mL isopropanol |
| -MAX: | 350 L | MOBILE PHASE: | 40% isopropanol/60% hexane isocratic, 1 mL/min |
| SHIPMENT: | routine | COLUMN: | silica (25-cm x 4.6-mm x 6.4- mm stainless steel, US pharmacopeia (USP) L18) |
| SAMPLE STABILITY: | 7 days @ 25 °C | DETECTOR: | UV @ 375 nm |
| BLANKS: | 2 to 10 field blanks per set | CALIBRATION: | solutions of <i>p</i> -nitroaniline in isopropanol |
| ACCURACY | | RANGE: | 100 to 2000 µg per sample [1] |
| RANGE STUDIED: | 3.9 to 12.9 mg/m ³ (90-L samples) [1] | ESTIMATED LOD: | 20 µg/sample [1] |
| BIAS: | -1.7% | PRECISION (\bar{S}_r): | 0.020 [1] |
| OVERALL PRECISION ($\hat{S}_{r,T}$): | 0.054 for range studied [1] | | |
| ACCURACY: | ± 11% | | |

APPLICABILITY: The working range is 1.1 to 22 mg/m³ for a 90-L air sample. This method is applicable to *p*-nitroaniline aerosol but not for environments where vapor may be present.

INTERFERENCES: None identified

OTHER METHODS: This revises Method S7 [2].

REAGENTS:

1. *p*-Nitroaniline, 99%.*
2. Isopropanol, distilled in glass.*
3. Hexane, distilled in glass.*
4. Calibration stock solution, 10 mg/mL.
Dissolve 0.100 g *p*-nitroaniline in 10 mL 2-propanol.

*See SPECIAL PRECAUTIONS.

EQUIPMENT:

1. Sampler: mixed cellulose ester (MCE) membrane filter (37-mm) and cellulose backup pad (37- mm) in a 2-piece filter holder held together by shrinkable band.
2. Personal sampling pump, calibrated, capable of operating 8 h at 1 to 3 L/min, with flexible connecting tubing.
3. HPLC with UV detector (375 nm), silica column (USP L18), injector, and electronic integrator (5033-1).
4. Microliter syringes, various sizes.
5. Volumetric flasks, various sizes.
6. Squat form ointment jars with polytetrafluoroethylene (PTFE) gaskets and screw caps.
7. Pipet, 5-mL, with pipet bulb.
8. Tweezers.

SPECIAL PRECAUTIONS: *p*-Chlorophenol is toxic by skin absorption, inhalation, or ingestion. It also is a strong irritant to tissue and is combustible with a flash point of 121 °C. Work should be performed in hood

SAMPLING:

1. Calibrate each personal sampling pump with a representative sampler in line.
2. Remove the front and rear plugs immediately before sampling and attach sampler to personal sampling pump with flexible tubing. Sample at a known flowrate between 1 and 3 L/min and collect a total sample of 16 to 350 L of air.
3. Cap the filters, record sample identity and all relevant sample data (duration, ambient temperature and pressure).
4. Prepare blank sample filters by handling in the same manner (open, seal, and transport) as samples except that no air is sampled through the blanks.
5. Ship in suitable container with blanks.

SAMPLE PREPARATION:

6. Open the filter holder and using tweezers, transfer each mixed cellulose ester filter to an ointment jar.
7. Add 5 mL isopropanol, cap, and swirl the jar to ensure that the filter is thoroughly wetted.

CALIBRATION AND QUALITY CONTROL:

8. Calibrate daily with at least six working standards.
 - a. Dilute aliquots of *p*-nitroaniline stock solution with isopropanol in volumetric flasks to encompass the range of interest.
 - b. Prepare calibration graph (peak area vs. µg *p*-nitroaniline per sample).
9. Determine the recovery (R) of the filters at least once for each lot of filters used in the range of interest.
 - a. Using a microliter syringe, spike 6 filters at each of 3 concentration levels with *p*-nitroaniline in isopropanol. Allow the filters to dry overnight for solvent evaporation.
 - b. Analyze the spiked filters. Prepare graph of µg recovered vs. µg spiked.

10. Analyze three quality control blind spikes and three analyst spikes to ensure that the calibration graph and recovery graph are in control.

MEASUREMENT:

11. Set HPLC according to manufacturer's recommendations and to conditions on page 5033-1.
12. Separation is achieved on a silica column using a mobile phase of 40% isopropanol/60% hexane at 1 mL/min. Inject 20- μ L sample aliquot.
NOTE: If peak area is above the linear range of the working standards, dilute with isopropanol and apply the appropriate dilution factor in calculations.
13. Measure peak areas.

CALCULATIONS:

14. Determine the mass of *p*-nitroaniline, μ g (corrected for recovery), for the sample (*W*) and average media blank (*B*).
15. Calculate the concentration of *p*-nitroaniline, *C* (mg/m³), in the air volume sampled, *V* (L):

$$C = \frac{W - B}{V}, \text{mg/m}^3$$

EVALUATION OF METHOD:

The method is not applicable to environments where *p*-nitroaniline vapor is present. However, experiments indicate that less than 0.04 mg/m³ of *p*-nitroaniline would exist as a vapor at 40 °C [1]. Extraction efficiencies of spiked filters containing 0.278, 0.556, or 1.112 mg of *p*-nitroaniline were 96.6%, 94.7%, and 94.6%, respectively [1]. Samples generated to measure the filter's collection efficiency at 1.5 L/min for concentration of 3.9, 6.75, and 12.88 mg/m³ showed recoveries of 95.9%, 98.8%, and 100.9% respectively [1]. The average recovery for 7-day-old samples was 98.6% [1].

REFERENCES:

- [1] NIOSH [1977]. Back-up data report for *p*-Nitroaniline: Method S7. Unpublished.
- [2] NIOSH [1977]. *p*-Nitroaniline: Method S7. In: Taylor DG, ed. NIOSH manual of analytical methods. 2nd ed. Cincinnati, OH: U.S. Department of Health, Education, and Welfare, Center for Disease Control, National Institute for Occupational Safety and Health, DHEW (NIOSH) Publication No. 77-157-B.
- [3] NIOSH [1981]. Occupational health guidelines for chemical hazards. Cincinnati, OH: U.S. Department of Health and Human Services, Centers for Disease Control, National Institute for Occupational Safety and Health, DHHS (NIOSH) Publication No. 81-123. Available as #PB 83-154609 from NTIS.

METHOD REVISED BY:

Charles Neumeister, NIOSH.

Disclaimer: Mention of any company or product does not constitute endorsement by NIOSH. In addition, citations to websites external to NIOSH do not constitute NIOSH endorsement of the sponsoring organizations or their programs or products. Furthermore, NIOSH is not responsible for the content of these websites. All web addresses referenced in this document were accessible as of the publication date.

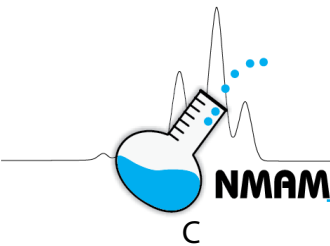

DIESEL PARTICULATE MATTER (as Elemental Carbon)

5040

C

MW: 12.01

CAS: none

RTECS: none

METHOD: 5040, Issue 4

EVALUATION: FULL

Issue 1: 15 May 1996

Issue 2: 10 March 2016

OSHA: None
NIOSH: None

PROPERTIES: nonvolatile solid

SYNONYMS: diesel particulate matter, diesel exhaust, diesel soot, diesel emissions

| SAMPLING | MEASUREMENT |
|--|--|
| <p>SAMPLER: FILTER: quartz-fiber, 37-mm or 25-mm; size-selective sampler may be required [1]</p> <p>FLOW RATE: 2 to 4 L/min (typical)</p> <p>VOL-MIN: 142 L @ 40 µg/m³ -MAX: 19 m³ (for filter load of ~ 90 µg/cm²)</p> <p>SHIPMENT: Routine.</p> <p>SAMPLE STABILITY: Stable.</p> <p>BLANKS: 2 to 10 field blanks per set</p> | <p>TECHNIQUE: Thermal-optical analysis; flame ionization detector (FID)</p> <p>ANALYTE: Elemental carbon (EC). Total carbon is determined, but an EC exposure marker was proposed. See [1] for details.</p> <p>FILTER PUNCH SIZE: 1.5 cm² (or other [1])</p> <p>CALIBRATION: Methane injection</p> <p>RANGE: 1 to 105 µg per filter portion (See also [1].)</p> <p>ESTIMATED LOD: 0.3 µg per filter portion</p> <p>PRECISION (\bar{S}_r): 0.19 @ 1 µg C, 0.01 @ 10 to 72 µg C</p> |
| ACCURACY | |
| <p>RANGE STUDIED: 23 to 240 µg/m³ (See also ref. [1].)</p> <p>BIAS: None (See also ref. [1].)</p> <p>OVERALL PRECISION (\hat{S}_{rT}): 0.07</p> <p>ACCURACY: ± 16.7% at 23 µg/m³ (See also ref. [1].)</p> | |

APPLICABILITY: The working range is approximately 6 to 630 µg/m³, with an LOD of ~ 2 µg/m³ for a 960-L air sample collected on a 37-mm filter with a 1.5 cm² punch from the sample filter. If a lower LOD is desired, a larger sample volume and/or 25-mm filter may be used (e.g., a 1920-L sample on 25-mm filter gives an LOD of 0.4 µg/m³). The split between organic carbon (OC) and EC may be inaccurate if the sample transmittance is too low. The EC loading at which this occurs depends on laser intensity. In general, the OC-EC split may be inaccurate when EC loadings are above 20 µg/cm². High loadings can give low (and variable) EC results because the transmittance remains low and relatively constant until some of the EC is oxidized. The split should be reassigned (prior to EC peak) in such cases [2]. An upper EC limit of 800 µg/m³ (90 µg/cm²) can be determined. Low EC loadings (e.g., near the LOD) also may require a manual split to improve accuracy [1].

INTERFERENCES: Total carbon (as OC and EC) is determined by the method, but EC was recommended as a measure of workplace exposure because OC interferences may be present [1,2]. Cigarette smoke and carbonates ordinarily do not interfere in the EC determination. Less than 1% of the carbon in cigarette smoke is elemental. If heavy loadings of carbonate or organic dusts are anticipated, a size-selective sampler (impactor and/or cyclone) should be used [1]. For measurement of diesel-source EC in coal mines, a cyclone and impactor with a submicrometer cutpoint are required to minimize collection of coal dust. A cyclone and/or impactor may be necessary in other workplaces if EC-containing dusts are present.

OTHER METHODS: Other methods for determination of EC and OC have been employed, but these are not equivalent to the method described herein. Information on other methods is summarized elsewhere [1]. The method procedures are unchanged from the 4th edition supplement to NMAM, but the corresponding diesel guidance chapter was updated for the 5th edition.

REAGENTS:

1. Aqueous solutions of reagent grade (99+%) sucrose, 0.1 to 3 mg C per mL solution. Ensure filter spike loading range brackets that of samples.
2. Ultrapure H₂O, Type I, or equivalent.
3. UHP helium (99.999%), scrubber also required for removal of oxygen.
4. Hydrogen, purified (99.995%), cylinder or hydrogen generator source.
5. Ultra Zero air (low hydrocarbon).
6. 10% oxygen in helium balance, both gases UHP, certified mix.
7. 5% methane in helium balance, both gases UHP, certified mix.

EQUIPMENT:

1. Sampler: Quartz-fiber filter, precleaned (in low temperature asher 2 to 3 h, or muffle furnace for 1 to 2 h at ~ 800 °C), 37-mm, in a 3-piece cassette with filter support (stainless steel screen, cellulose pad, or a second quartz filter). Alternative samplers may be required in dusty environments. See ref. [1] for details.

NOTE 1: High purity, high efficiency, binder-free quartz-fiber filters must be used (e.g., Pall Gelman Sciences Pallflex Tissuequartz 2500QAT-UP). Precleaned filters are available from several laboratories. Filters also can be purchased and cleaned in-house. Filters should be cleaned in a muffle furnace operated at 800-900 °C for 1-2 hours. Check (analyze) filters to ensure removal of OC contaminants. A shorter cleaning period may be effective. OC results immediately after cleaning should be below 0.1 µg/cm². OC vapors readily adsorb on to clean filters. Even when stored in closed containers, OC loadings may range from 0.5 µg/cm² after several weeks.

NOTE 2: Cellulose supports give higher OC blanks than screens and quartz filters. Bottom quartz filters can be used to correct for adsorbed vapor; see ref. [1].

2. Personal sampling pump with flexible tubing.
3. Thermal-optical analyzer; see ref. [1].
4. Metal punch for removal of 1.5 cm² rectangular portion of filter.

NOTE: A smaller portion (e.g., taken with cork borer) may be used, but the area must be large enough to accommodate the entire laser beam (i.e., beam should pass through the sample, not around it). The area of the portion must be accurately known, and the sample must be carefully positioned (the filter transmittance will decrease dramatically when the sample is properly aligned). A filter portion ≥ 0.5 cm² with diameter or width ≤ 1 cm is recommended.

5. Syringe, 10-µL.
6. Aluminum foil.
7. Needle (for lifting filter punch portion).
8. Forceps
9. Volumetric flasks, Class A.
10. Analytical balance.

SPECIAL PRECAUTIONS: Hydrogen is a flammable gas. Users must be familiar with the proper use of flammable and nonflammable gases, cylinders, and regulators. According to the instrument manufacturer, the instrument is a Class I Laser Product. This designation means there is no laser radiation exposure during normal operation. Weakly scattered laser light is visible during operation, but does not pose a hazard to the user. The internal laser source is a Class IIIb product, which poses a possible hazard to the eye if viewed directly or from a mirror-like surface (i.e., specular reflections). Class IIIb lasers normally do not produce a hazardous diffuse reflection. Repairs to the optical system, and other repairs requiring removal of the instrument housing, should be performed only by a qualified service technician.

SAMPLING:

1. Calibrate each personal sampling pump with a representative sampler in line.

NOTE: Both open and closed-faced cassettes have been used. Both configurations generally give even deposits. At higher flow rates (e.g., 4 L/min), small spots occasionally have been observed in the center of the filters when closed-faced cassettes are used. This material likely consisted of impacted diesel agglomerates and/or non-diesel particulate matter. EC results for multiple portions of the filters were in good agreement, so the spots had little analytical impact. Other samplers also can be used (see ref. [1]) provided an even deposit of diesel particulate results. An even deposit is necessary because the sample portion analyzed must be representative of the entire deposit. If the deposit is not homogeneous, the entire sample must be analyzed. An impactor/cyclone may be needed in some cases [1].

2. Attach sampler outlet to personal sampling pump with flexible tubing.
3. Sample at an accurately known flow rate. Typical rates are 2-4 L/min (note: Lower flows (e.g., 1 L/min) have been used in mines to prevent overloading).
4. After sampling, replace top piece of cassette, if removed, and pack securely for shipment to laboratory.

NOTE: Diesel particulate samples from occupational settings generally do not require refrigerated shipment unless there is potential for exposure to elevated temperatures (that is, well above collection temperature). Filter samples normally are stable under laboratory conditions. Some OC loss may occur over time if samples contain OC from other sources (for example, cigarette smoke). Sorption of OC vapor after sample collection has not occurred, even with samples having high (e.g., 80%) EC content.

SAMPLE PREPARATION:

5. Place sample filter on a freshly cleaned aluminum foil surface. Isopropyl alcohol or acetone can be used to clean the foil. Allow residual solvent to vaporize from the surface prior to use. Punch out a representative portion of the filter. Take care not to disturb deposited material and avoid hand contact with sample. A needle inserted at an angle is useful for removal of the filter portion from the punch body. Newer instruments have an externally mounted bracket to support the quartz sample holder while the previous sample is removed and a new one is loaded. Through a hole in the side of the standard punch, a needle can be used to push the filter portion from the punch onto the sample holder. Alternative approaches also can be used, depending on the user's preference, as long as contamination is avoided.

CALIBRATION AND QUALITY CONTROL:

6. Analyze at least one replicate sample. For sets of up to 50 samples, replicate 10 % of the samples. For sets over 50 samples, replicate 5 % of the samples. If a filter deposit appears uneven (this should not be the case if the cassette is sealed properly), take a second portion (step 5) for analysis to check evenness of deposition.

NOTE: Precision of replicate analyses of a filter is usually better than 5% (1 to 3% is typical).

7. Analyze three quality control blind spikes and three analyst spikes to ensure that instrument calibration is in control. Prepare spike as follows:

- a. With 10- μ L (or other) syringe, apply an aliquot of OC standard solution directly to filter portion taken (step 5) from a precleaned filter. For best results, the precleaned filter punch should be cleaned again in the sample oven prior to application of the aliquot.
NOTE: With small aliquots (e.g., $\leq 10 \mu\text{L}$), disperse standard solution over one end of filter portion to ensure standard is in laser beam. To prevent possible solution loss to surface, hold the portion off the surface. Larger volumes can easily penetrate to the underside of the filter portion.
 - b. Allow water to evaporate and analyze spikes with samples and blanks (steps 9 and 10).
NOTE: A pronounced decrease in filter transmittance during the *first* temperature step of the analysis indicates water loss. Allow portions to dry longer if this occurs. Spiked punches also can be dried in the oven, if desired. For quick drying, the 'clean oven' command on the menu can be selected and canceled after about 4 seconds. The time allowed may depend on instrument, but oven temperatures should be below 100 °C to avoid boiling the solution. This approach is convenient and prevents potential adsorption of organic vapors in laboratory air. Some software versions may not have this feature.
8. Determine instrument blank (results of analysis with freshly cleaned filter portion) for each sample set.

MEASUREMENT:

9. Adjust analyzer settings according to manufacturer's recommendations (see instrument operation manual and background information in ref. [1]). Place sample portion into sample oven.
NOTE: Forms of carbon that are difficult to oxidize (e.g., graphite) may require a longer period and higher temperature during the oxidative mode to ensure that all EC is removed (the EC peak should never merge with the calibration peak.) Adjust time and temperature accordingly. A maximum temperature above 940 °C should not be required.
10. Determine EC (and OC) mass, μg . Analyzer results are reported in units $\mu\text{g}/\text{cm}^2$ of C. The reported values are normally based on a sample portion of about 1.5 cm^2 , which is the area of the standard punch provided by the manufacturer. If the portion area used differs from the value entered in the oecpar.txt file, multiply the result by 1.5 (or value in oecpar.txt file) and divide the product by the actual area analyzed to obtain the area-corrected result (i.e., reported result $\times 1.5 / \text{portion area} = \text{corrected result in } \mu\text{g}/\text{cm}^2$). This is most easily done in the data spreadsheet. Alternatively, the correct results will be obtained with the data calculation program if the portion area is entered in the parameter file (oecpar.txt), but this approach is error prone and tedious when punches of different areas are used for a sample set because correct results will not be obtained for all punch sizes. Updated software avoids this potential problem by prompting entry of the sample punch area prior to the analysis.

CALCULATIONS

11. Multiply the reported (or area-corrected) EC result ($\mu\text{g}/\text{cm}^2$) by filter *deposit area*, cm^2 , (typically 8.5 cm^2 for a 37-mm filter) to calculate total mass, μg , of EC on each filter sample (W_{EC}). Do the same for the blanks and calculate the mass found in the average field blank (W_{b}). The mass of OC is calculated similarly, but the mean OC field blank may underestimate the amount of OC contributed by adsorbed vapor. A quartz filter placed beneath the sample filter can provide a better estimate of the adsorbed OC [1].
12. Calculate the EC concentration (C_{EC}) in the air volume sampled, V (L):

$$C_{\text{EC}} = \frac{W_{\text{EC}} - W_{\text{b}}}{V}, \text{mg}/\text{m}^3$$

EVALUATION OF METHOD:

Details on the evaluation of this method are provided in an NMAM guidance chapter on diesel [1]. The chapter includes a summary of interlaboratory comparison work conducted since the initial publication of the method. Background information and guidance on method use, including sampling requirements, also are provided. In general industry, 37-mm or 25-mm cassettes are normally suitable for air sampling, but there are exceptions. A cyclone in series with an impactor having a submicrometer cutpoint must be used in coal mines, and the Mine Safety and Health Administration (MSHA) has recommended use of a cyclone-impactor sampler in metal and nonmetal mines [3]. The impactor is commercially available through SKC, Inc. A size-selective sampler (either impactor and/or cyclone) also may be required in other dusty environments [1], particularly if the dust is carbonaceous. If a sample contains carbonate, the carbonate carbon (CC) will be quantified as OC. A carbonate-subtracted result can be obtained through acidification of the sample portion or through separate integration of the carbonate peak [1] (Note: Trona and other compounds containing sodium can etch the quartz oven wall during the analysis. Avoid spillage in the sample oven and frequent analysis of these materials.) These procedures are described in a Chapter of this Manual [1]. The thermal-optical method is applicable to nonvolatile carbon species (i.e., particulate OC, CC and EC). The method is not appropriate for volatile or semivolatiles, which require sorbents for efficient collection.

REFERENCES:

- [1] NIOSH [2016]. Chapter DE: Monitoring of diesel particulate exhaust in the workplace. In: O'Connor PF, Ashley K, eds. NIOSH manual of analytical methods. 5th ed. Cincinnati, OH: U.S. Department of Health and Human Services, Centers for Disease Control and Prevention, National Institute for Occupational Safety and Health, DHHS (NIOSH) Publication No. 2014-151.
- [2] Birch ME, Cary RA [1996]. Elemental carbon-based method for monitoring occupational exposures to particulate diesel exhaust. *Aerosol Sci Tech* 25:221-241.
- [3] 66 Fed. Reg. 13 [2001]. Department of Labor, Mine Safety and Health Administration: Diesel particulate matter exposure of underground metal and nonmetal miners; final rule. (To be codified at 30 CFR Part 57).

METHOD REVISED BY:

M. Eileen Birch, Ph.D., NIOSH

Disclaimer: Mention of any company or product does not constitute endorsement by NIOSH. In addition, citations to websites external to NIOSH do not constitute NIOSH endorsement of the sponsoring organizations or their programs or products. Furthermore, NIOSH is not responsible for the content of these websites. All web addresses referenced in this document were accessible as of the publication date.



CARBON BLACK

5100

C

MW: 12.01

CAS: 1333-86-4

RTECS: FF5800000

METHOD: 5100, Issue 1

EVALUATION: FULL

Issue 1: 30 April 2015

OSHA: 3.5 mg/m³[1]

NIOSH: 3.5 mg/m³ (in presence of PAHs: carcinogen/PAHs to 0.1 mg/m³, cyclohexane extractable fraction) [2]

PROPERTIES: Solid; may contain polynuclear aromatic hydrocarbons (PAHs)

For other OELs

and guidelines: See references [3,4]

SYNONYMS: Acetylene black; amorphous carbon; furnace black; lamp black

| SAMPLING | | MEASUREMENT | |
|---|--|--|--|
| SAMPLER: | INTERNAL CAPSULE, (tared 37-mm, 2- to 5- μ m PVC filter melded to PVC housing) in 37-mm 2-piece cassette | TECHNIQUE: | GRAVIMETRIC (INTERNAL CAPSULE WEIGHT) |
| FLOW RATE: | 1 to 2 L/min | ANALYTE: | Carbon black |
| VOL-MIN: | 75 L @ 3.5 mg/m ³ | BALANCE: | 0.001 mg sensitivity; use same balance before and after sample collection |
| -MAX: | 1400 L @ 3.5 mg/m ³ | CALIBRATION: | National Institute of Standards and Technology (NIST), Class S-1.1 weights or ASTM Class 1 weights |
| SHIPMENT: | Routine | RANGE: | 0.25 to 5 mg per sample |
| SAMPLE STABILITY: | 28 days minimum | ESTIMATED LOD: | 0.075 mg per sample |
| BLANKS: | Minimum of 2 field blanks per batch | PRECISION (\bar{S}_r): | 0.031 at 2 mg per sample [5] |
| ACCURACY | | | |
| RANGE STUDIED: | 0.1 to 4 mg/sample | | |
| BIAS: | 0.058 [5] | | |
| OVERALL PRECISION (\bar{S}_{rT}): | 0.059 [5] | | |
| ACCURACY: | $\pm 15.5\%$ | | |

APPLICABILITY: The working range is 1.5 to 25 mg/m³ for a 200-L air sample. This method is not applicable for the determination of "cyclohexane-solubles" [3]. The method is nonspecific; information on any other particulate materials that may be present should be assessed.

INTERFERENCES: Moisture and static electricity can affect gravimetric measurements. Humidity control and minimization of static effects are addressed in this procedure. The presence of co-sampled airborne particulate material is a positive interference since this is a gravimetric method.

OTHER METHODS: This method is preferred over Method 5000, Issue 2 [6], and is similar to Method 0501 for particulates not otherwise regulated [8]. OSHA method PV2121 describes a similar procedure (but for respirable sampling) using an alternative sampler design [9].

EQUIPMENT:

1. Sampler: Internal capsule, 37-mm PVC, 2- to 5- μ m pore size membrane or equivalent hydrophobic filter attached to PVC housing and supporting pad in 37-mm 2-piece cassette filter holder
NOTE: The cassettes should be fabricated so as to ensure complete sealing of the internal capsule after sample collection.
2. Personal sampling pump, 1 to 2 L/min, with flexible connecting tubing
3. Microbalance capable of weighing to ± 0.001 mg
4. Static neutralizer; e.g. ^{210}Po ; replace no more than nine months after production date
5. Tool for handling internal capsules, e.g., forceps (preferably plastic)
6. Environmental chamber or room for balance (e.g. 20 ± 1 °C and $50 \pm 5\%$ RH)

SPECIAL PRECAUTIONS: Carbon black containing polynuclear aromatic hydrocarbons (cyclohexane - extractable materials) in excess of 0.1% (w/w) should be treated as a suspect carcinogen [3].

PREPARATION OF FILTER CAPSULES BEFORE SAMPLING:

1. Equilibrate the PVC filter capsules in an environmentally controlled weighing area or chamber for at least 24 h.
NOTE: An environmentally controlled chamber is desirable, but not required.
2. Place backup pads in filter cassette bottom sections.
3. Weigh the filter capsules in an environmentally controlled area or chamber. Record the capsule tare weight, W_1 (mg).
 - a. Zero the balance before each weighing.
 - b. Handle the filter capsule with forceps. Pass the capsule over an antistatic radiation source. Repeat this step if the capsule does not release easily from the forceps or if it attracts balance pan. Static electricity can cause erroneous weight readings.
4. Assemble the filter capsules in the filter cassettes and close firmly so that leakage around the internal capsule will not occur. Place a plug in each opening of the filter cassette. Place a cellulose shrink band around the filter cassette, allow to dry, and label the cassette with indelible ink.

SAMPLING:

5. Calibrate each personal sampling pump with a representative sampler in line.
6. Sample at 1 to 2 L/min for a total sample volume of 75 to 1400 L. Do not exceed a filter capsule loading of approximately 5 mg total dust. Take two to four replicate samples for each batch of field samples for quality assurance on the sampling procedure.

SAMPLE PREPARATION:

7. Wipe dust from the external surface of the filter cassette with a moist paper towelette to minimize contamination. Discard the towelette.
8. Remove the top and bottom plugs from the filter cassette. Equilibrate for at least 24 h in the balance room.
9. Using forceps, open the cassette and remove the internal capsule gently to avoid loss of dust or damage to the capsule.

CALIBRATION AND QUALITY CONTROL:

10. Zero the microbalance before all weighings. Use the same microbalance for weighing filter capsules before and after sample collection. Calibrate the balance with National Institute of Standards and Technology Class S-1.1 or ASTM Class 1 weights.
11. Process laboratory blanks, spiked QC samples and field blanks at a minimum frequency of 1 per 20 field samples. Internal capsules used for QC samples should come from the same lot. Spiked QC samples, loaded with 0.25 to 4 mg of material per internal capsule, should be prepared using weight-stable material such as Arizona Road Dust [10].

MEASUREMENT:

12. Weigh each capsule, including field blanks. Record the post-sampling weight, W_2 (mg). Record anything remarkable about a capsule (e.g., overloading, leakage, wet, torn, etc.).

CALCULATIONS:

13. Calculate the concentration, C (mg/m³), of carbon black in the air volume sampled, V (L):

$$C = \frac{(W_2 - W_1) - (B_2 - B_1)}{V} 10^3, \text{ mg/m}^3$$

where: W_1 = tare weight of capsule before sampling (mg)

W_2 = post-sampling weight of sample-containing capsule (mg)

B_1 = mean tare weight of blank capsules (mg)

B_2 = mean post-sampling weight of blank capsules (mg)

EVALUATION OF METHOD:

Lab testing was carried out using blank internal capsules and with capsules spiked with 0.1 – 4 mg of NIST SRM 1648 (Urban Particulate Matter) and Arizona Road Dust (Air Cleaner Test Dust) [5]. Precision and accuracy data are given on page 5100-1. Weight stability over 28 days was verified for both blanks and spiked capsules [5]. Independent laboratory testing on blanks and field samples have verified long-term weight stability as well as sampling and analysis uncertainty estimates [5].

REFERENCES:

- [1] CFR. 29 CFR Part 1910.1000. Code of Federal Regulations. Washington, DC: U.S. Government Printing Office, Office of the Federal Register.
- [2] NIOSH [2005]. NIOSH pocket guide to chemical hazards. Barsan ME, ed. Cincinnati OH: U.S. Department of Health and Human Services, Centers for Disease Control and Prevention, National Institute for Occupational Safety and Health. DHHS (NIOSH) Publication no. 2005-149.
- [3] ACGIH [2013]. TLVs and BEIs based on the documentation of the Threshold Limit Values for chemical substances and physical agents and Biological Exposure Indices. Cincinnati, Ohio: American Conference of Governmental Industrial Hygienists. [www.acgih.org]. [Date accessed: February, 2015.]
- [4] Institut für Arbeitsschutz der Deutschen Gesetzlichen Unfallversicherung [2014]. GESTIS-Database on hazardous substances. (German Social Accident Insurance). Sankt Augustin, Germany: IFA. <https://www.dguv.de/ifa/index-2.jsp> [Date accessed: February, 2015.]

- [5] NIOSH [2014]. Backup Data Report-NIOSH 0501 and 5100. By O'Connor SP, O'Connor PF, Feng HA, Ashley K. Cincinnati, OH: U.S. Department of Health and Human Services, Centers for Disease Control and Prevention, National Institute for Occupational Safety and Health. [http://www.cdc.gov/niosh/docs/2003-154/pdfs/bud/1453_bud.pdf].
- [6] NIOSH [1994]. Carbon black: Method 5000. In: Eller PM, Cassinelli ME, eds. NIOSH manual of analytical methods. 4th ed. Cincinnati, OH: U.S. Department of Health and Human Services, Centers for Disease Control and Prevention, National Institute for Occupational Safety and Health, DHHS (NIOSH) Publication No. 94-113 [www.cdc.gov/niosh/nmam/].
- [7] NIOSH [1994]. Particulates not otherwise regulated, total: Method 0500. In: Eller PM, Cassinelli ME, eds. NIOSH manual of analytical methods. 4th ed. Cincinnati, OH: U.S. Department of Health and Human Services, Centers for Disease Control and Prevention, National Institute for Occupational Safety and Health, DHHS (NIOSH) Publication No. 94-113 [www.cdc.gov/niosh/nmam/].
- [8] NIOSH [2015]. Particulates not otherwise regulated, total: Method 0501. In: Ashley KE, O'Connor PF, eds. NIOSH manual of analytical methods. 5th ed. Cincinnati, OH: U.S. Department of Health and Human Services, Centers for Disease Control and Prevention, National Institute for Occupational Safety and Health, DHHS (NIOSH) Publication No. 2014-151. [www.cdc.gov/niosh/nmam/].
- [9] OSHA [2003]. Gravimetric determination: PV2121. In: Monitoring methods used by OSHA. Salt Lake City, UT: U.S. Department of Labor, Occupational Safety and Health Administration. [<https://www.osha.gov/dts/sltc/methods/partial/pv2121/pv2121.html>] (Date accessed: February, 2015).
- [10] O'Connor S, O'Connor PF, Feng HA, Ashley K [2014]. Gravimetric analysis of particulate matter using air samplers housing internal filtration capsules. *Gefahrstoffe Reinh Luft* 75: 403-410.

METHOD WRITTEN BY: Kevin Ashley, Ph.D., NIOSH/DART

Disclaimer: Mention of any company or product does not constitute endorsement by NIOSH. In addition, citations to websites external to NIOSH do not constitute NIOSH endorsement of the sponsoring organizations or their programs or products. Furthermore, NIOSH is not responsible for the content of these websites. All web addresses referenced in this document were accessible as of the publication date.

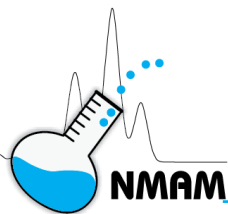

ORGANOTIN COMPOUNDS (as Sn)

5504

Table 1

MW: Table 1

CAS: Table 1

RTECS: Table 1

METHOD: 5504, Issue 3

EVALUATION: FULL

Issue 1: 15 August 1987

Issue 3: 4 February 2016

OSHA: 0.1 mg/m³
NIOSH: 0.1 mg/m³ (skin)

PROPERTIES: Table 1

SYNONYMS: Table 1

| SAMPLING | | MEASUREMENT | |
|---|--|--|---|
| SAMPLER: | FILTER + SORBENT (glass fiber + XAD-2, 80 mg/40 mg) | TECHNIQUE: | HPLC/ATOMIC ABSORPTION, GRAPHITE FURNACE |
| FLOW RATE: | 1 to 1.5 L/min | ANALYTE: | tin |
| VOL-MIN: | 50 L | DESORPTION: | 10 mL 0.1% acetic acid/H ₃ CN; ultrasonic, 30 min |
| -MAX: | 500 L | SEPARATION: | HPLC (C18 or cation exchange column) |
| SHIPMENT: | ship assembled sampler in dry ice | GRAPHITE FURNACE: | dry 30 sec @ 80 °C; atomize 5 sec @ 2750 °C (gas interrupt mode) |
| SAMPLE STABILITY: | stable 7 days @ 0 °C [1] | INJECTION VOLUME: | 20 µL |
| FIELD BLANKS: | 2 to 10 field blanks per set | WAVELENGTH: | 286.3 nm, with background correction |
| MEDIA BLANKS: | 12 per sample set | CALIBRATION: | standard solutions of organotin compounds in acetic acid/CH ₃ CN |
| ACCURACY | | RANGE: | 5 to 50 µg Sn per sample |
| RANGE STUDIED: | 0.07 to 0.2 mg/m ³ [1] (300-L samples) | ESTIMATED LOD: | 1 µg Sn per sample [1] |
| BIAS: | see EVALUATION OF METHOD | PRECISION (\bar{S}_r): | 0.07 to 0.08 [1] |
| OVERALL PRECISION (\hat{S}_{rT}): | 0.07 to 0.10 [1] | | |
| ACCURACY: | see EVALUATION OF METHOD | | |

APPLICABILITY: The working range is 0.015 to 1 mg/m³ (as Sn) for a 300-L air sample. The method was validated using TeBT, TBTC, TCHH, and BuLOMA as surrogates for the most important classes of organotin compounds [1]. If speciation of organotin compounds is not required and if inorganic tin compounds are absent, the HPLC separation may be deleted. Use special care to avoid losses of TeBT and other volatile tetra-substituted organotin compounds

INTERFERENCES: Organotin compounds not separated chromatographically will mutually interfere. Other compounds with similar retention times will not interfere unless they contain tin.

OTHER METHODS: This replaces the colorimetric criteria document method [2].

REAGENTS:

1. Zirconium acetate oxide, reagent grade.
2. Ammonium acetate, reagent grade.
3. Diammonium citrate, reagent grade.
4. Acetonitrile, chromatographic grade.
5. Deionized water.
6. Acetic acid, glacial, reagent grade.
7. Methanol, chromatographic grade.
8. Acetic acid, 0.1% (v/v) in acetonitrile.
9. Acetate buffer solution (v/v) 70% methanol, 27% deionized water, 3% aqueous 1 M ammonium acetate.
10. Citrate buffer solution (v/v) 70% methanol, 26.8% deionized water, 3% aqueous 1 M diammonium citrate in 0.2% (v/v) glacial acetic acid.
11. Organotin standard solutions, 1000 µg/mL (as Sn), prepared from pure organotin compounds in 0.1% (v/v) acetic acid in acetonitrile.
12. Calibration stock solution, 10 µg/mL (as Sn). Prepare a standard mixture of the organotin compounds of interest. Pipet 0.1 mL of each organotin standard solution into a 10-mL volumetric flask. Dilute to the mark with 0.1% (v/v) acetic acid in acetonitrile. Prepare fresh daily.

EQUIPMENT:

1. Sampler: glass fiber filter, 37-mm (commercially available) in cassette filter holder followed by XAD-2 sorbent tube, 80 mg front section/40 mg back section separated and retained by silanized glass wool (commercially available).
2. Personal sampling pump, 1 to 1.5 L/min, with flexible connecting tubing.
3. Shipping container, refrigerated, with dry ice.
4. High performance liquid chromatograph (HPLC), interfaced with autoinjection system (Fig. 1), with binary solvent capability, solvent gradient capability and columns:
 - a. non-tetraorganotin species: cation exchange column.
 - b. tetraorganotin compounds: C18 column
5. Atomic absorption spectrophotometer (AAS) having recorder output proportional to absorbance units, graphite furnace accessory (pyrolytic with Zr coating, coated L'vov platform may be required; see APPENDIX), sample autoinjection system with moving sample tube rack or carousel (Fig. 1), automatic micropipettor for accurately injecting 20-µL sample aliquots into graphite furnace, background correction (e.g., D₂ or H₂ lamp) capability, and tin electrodeless discharge lamp or hollow cathode lamp.
6. Bath, ultrasonic.
7. Volumetric flasks, 10-mL.
8. Syringe, 20-µL, readable to 0.5 µL.
9. Beakers, Phillips, 125-mL.
10. Pipets, 5- and 10-mL; 10- and 100-µL.
11. Oven or muffle furnace, 200°C.
12. Plastic film.

SPECIAL PRECAUTIONS: None.

SAMPLING:

1. Calibrate each personal sampling pump with a representative sampler in line.
2. Break the ends of the sorbent tube immediately before sampling and connect to the filter with a short piece of tubing. Attach sampler to personal sampling pump with flexible tubing.
3. Sample at an accurately known flow rate between 1 and 1.5 L/min for a total sample size of 50 to 500 L.
4. Cap the samplers. Pack securely for shipment in dry ice.

NOTE: The cassette and sorbent tube should remain connected for storage. Store samples at less than 0 °C. Analyze within seven days after collection.

SAMPLE PREPARATION:

5. Open the cassette filter holder. With tweezers, carefully transfer the filter to a 125-mL beaker.
6. Place the front sorbent section and front glass wool plug into a second beaker. Place the back sorbent section and remaining glass wool plugs into a third beaker.
7. Pipet 10.0 mL acetonitrile and 10 μ L acetic acid into each beaker. Cover with plastic film.
8. Agitate beakers in ultrasonic bath for 30 min.

CALIBRATION AND QUALITY CONTROL:

9. Calibrate daily with at least six working standards.
 - a. Add known amounts of calibration stock solution to 0.1% (v/v) acetic acid in acetonitrile in 10-mL volumetric flasks and dilute to the mark. Use serial dilutions as needed to obtain concentrations of each organotin compound in the range 0.1 to 5 μ g/mL (as Sn).
 - b. Analyze with samples and blanks (steps 12 through 15), alternating samples and standards with similar responses.
 - c. Prepare calibration graphs (peak height vs. μ g Sn) for each organotin compound.
10. Determine recovery (R) in the range of interest. Prepare three samplers at each of three levels plus three media blanks.
 - a. Remove and discard back sorbent section of a media blank sampler.
 - b. Inject a known amount (2 to 20 μ L) of organotin standard solution directly onto front sorbent section and a separate aliquot onto the filter, with a microliter syringe.
 - c. Cap the sampler. Allow to stand overnight.
 - d. Desorb (steps 5 through 8) and analyze with working standards (steps 12 through 15).
 - e. Prepare a graph of R vs. μ g Sn recovered for each organotin compound.
11. Analyze three quality control blind spikes and three analyst spikes to ensure that the calibration graphs and recovery graphs are in control.

MEASUREMENT:

12. Set the AAS and graphite furnace according to manufacturer's recommendations and to conditions on page 5504-1. Adjust the sample injection/dry/atomize cycle so that it occurs exactly once every 60 sec.
13. Operate the HPLC according to manufacturer's recommendations and the following conditions:
 - a. For non-tetraorganotin compounds:
 - (1) Column: strong cation exchange (EQUIPMENT, 4a).
 - (2) Flush column with 50 to 60 mL acetate buffer prior to sample injection.
 - (3) Eluent: flowrate = 2 mL/min
 - (4) Eluent Gradient:

| Time (min) | % Acetate Buffer | % Citrate Buffer |
|------------|------------------|------------------|
| 0-15 | 100 | 0 |
| 15-18 | 100-0 | 0-100 |
| 18-40 | 0 | 100 |

- (5) After the chromatogram is complete, re-equilibrate the HPLC system to initial conditions by pumping acetate buffer through the column for 15 min.
- (6) Inject 100- μ L sample aliquot.

- b. For tetraorganotin compounds:
- (1) Column: C18.
 - (2) Flush column with 50 to 60 mL of 100% acetonitrile prior to sample injection.
 - (3) Eluent: flowrate = 2 mL/min, isocratic, 100% acetonitrile.
 - (4) Inject a 100- μ L aliquot of sample solution.
14. Collect HPLC eluent at the rate of 1 fraction (2 mL) per minute in AAS autosampler (Fig. 1).
NOTE: In this example system, the column effluent is fed directly into one of the sample cups. After 1 min, the sample holder rotates and the eluted sample is in a position to be sampled for AA measurement. The furnace injection device withdraws a portion of the sample and places it in the furnace while the next sample is being eluted and collected.
15. Measure total AAS peak area for each organotin compound.
NOTE 1: The recorder output will consist of AA peaks which form a chromatographic peak for each organotin compound if a line is drawn connecting the highest points of the AA peaks. Determine total absorbance for a species by the sum of the absorbencies of the corresponding AA peaks.
NOTE 2: The characteristics of the graphite tube can influence the results drastically. Pay careful attention to the response of the standards and replace the graphite tube if erratic results and non-reproducible peak areas occur.

CALCULATIONS:

16. Read the mass, μ g Sn (corrected for R), for each organotin compound found on the filter (W) and front sorbent (W_f) and back sorbent (W_b) sections, and on the average media blanks [filter (B) and front sorbent (B_f) and back sorbent (B_b) sections] from the calibration graphs.
17. Calculate concentration, C (mg/m^3), for each organotin compound as Sn in air as the sum of the particulate concentration and the vapor concentration in the air volume sampled, V (L):

$$C = \frac{W - B + W_f + W_b - B_f - B_b}{V}, \text{mg}/\text{m}^3$$

NOTE: W_f and W_b will include any analyte originally collected on the filter as particulate, then volatilized during sampling or storage.

EVALUATION OF METHOD:

The method was validated with tetrabutyltin (TeBT), tributyltin chloride (TBTC), tricyclohexyltin hydroxide (TCHH), and dibutyltin bis(isooctylmercaptoacetate) (BuIOMa) [1]. The working ranges, validation ranges, and estimated linear working ranges (as tin) for 300-L air samples of these organotin species at an atmospheric temperature and pressure of 20 °C and 756 mm Hg, respectively, appear below:

| Species | Validation Range (mg/m^3) | Estimated linear Working Range (mg/m^3) | Estimated linear Working Range ($\mu\text{g}/\text{mL}$) | Measurement Precision (%) | Bias (%) | Overall Precision ($\pm\%$) | Accuracy |
|---------|---|---|--|---------------------------|----------|-------------------------------|----------|
| TeBT | 0.027-0.112 | 0.02-0.17 | 0.05-5.0 | 8.1 | +1.8 | 10.0 | 21.4 |
| TBTC | 0.042-0.191 | 0.01-0.34 | 0.3-10 | 5.9 | -6.7 | 9.9 | 26.1 |
| TCHH | 0.071-0.218 | 0.01-0.34 | 0.3-10 | 6.9 | -2.3 | 7.1 | 16.2 |
| BuIOMa | 0.070-0.220 | 0.01-0.34 | 0.3-10 | 7.7 | -1.2 | 7.4 | 15.7 |

The methods were developed using a Partisil-10 strong cation exchange column and a Solvecon precolumn kit (Whatman, Inc.) for the analysis of the non-tetraorganotin compounds. For the tetraorganotin compounds, a LiChrosorb RP-18 HPLC column (Whatman, Inc.) was used.

REFERENCES:

- [1] Gutknecht WF, Grohse PM, Homzak CA, Tronzo C, Ranade MH, and Damle A [1982]. Development of a method for the sampling and analysis of organotin compounds. Research Triangle Park, NC: Research Triangle Institute. NIOSH contract no. 210-80-0066. Available as order no. PB83-180737 from NTIS.
- [2] NIOSH [1976]. NIOSH criteria for a recommended standard: occupational exposure to organotin compounds. Cincinnati, OH: U.S. Department of Health, Education, and Welfare, Center for Disease Control, National Institute for Occupational Safety and Health, DHEW (NIOSH) Publication No. 77-115.

METHOD REVISED BY:

Eugene R. Kennedy, Ph.D., NIOSH

APPENDIX: Preparation of Zr-Coated Graphite Furnace Tube and Platform

1. Zirconium coating: soak pyrolytic graphite tubes and platforms overnight in 4.5% (w/v) zirconium acetate oxide solution; then dry in a muffle furnace for 2h at 200 °C.
2. Pyrolytic zirconium-coated graphite furnace tubes are acceptable for measurements of all organotin compounds. However, a pyrolytic zirconium-coated graphite platform (e.g., L'vov platform) is recommended for better precision at low levels and improved atomization response for volatile species such as TeBT. Platforms may be purchased commercially or prepared from pyrolytic graphite tubes, as shown in Fig. 2. Special care must be exercised during placement of the platform in the tube (Fig. 3) and in optical alignment

Table 1. Formulae and Physical Properties

| Compound/ RTECS | Formula | M.W. | % Sn | Synonym |
|---|------------------------|--------|------|--|
| Dibutyltin bis(isooctyl mercaptoacetate) WH6719000 | $C_{28}H_{56}O_4S_2Sn$ | 639.57 | 18.6 | BulOMA; CAS #25168-24-5 |
| Tetrabutyltin WH8605000 | $C_{16}H_{36}Sn$ | 347.16 | 34.2 | Stannane, tetrabutyl-; TeBT; CAS #1461-25-2 |
| Tributyltin chloride WH6820000 | $C_{12}H_{27}ClSn$ | 325.49 | 36.5 | Stannane, chlorotributyl-; TBTC; CAS #1461-22-9 |
| Tricyclohexyltin hydroxide WH8750000 | $C_{18}H_{34}OSn$ | 385.16 | 30.8 | Stannane, tricyclohexylhydroxy-; TCHH; CAS #13121-70-5 |

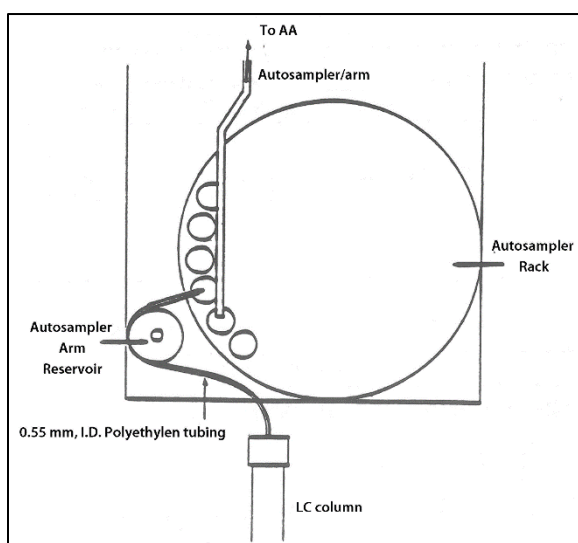
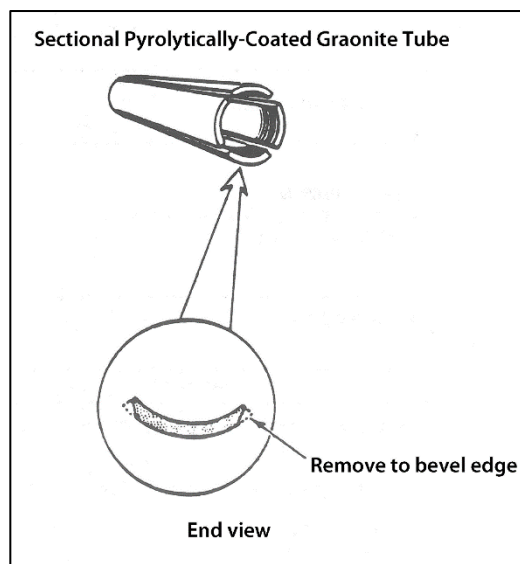
**Figure 1 HPLC/AAS interface system****Figure 2 Construction of a laboratory made platform**

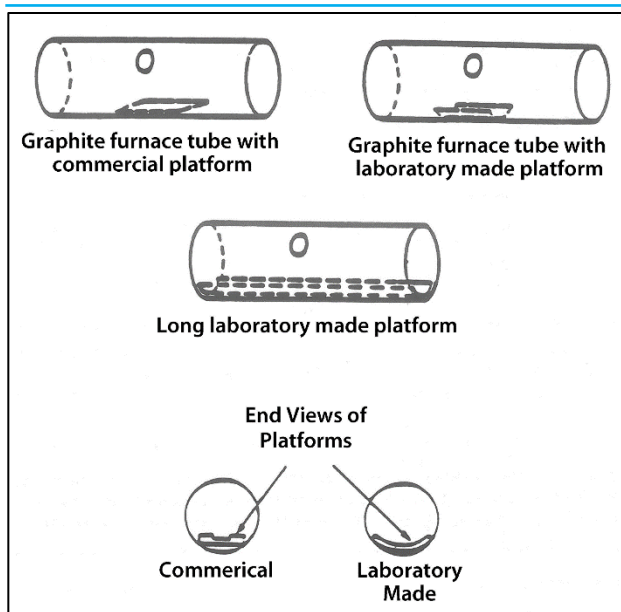

Figure 3 Placement of commercial and “laboratory-made” graphite L’vov platforms in furnace tubes.

Disclaimer: Mention of any company or product does not constitute endorsement by NIOSH. In addition, citations to websites external to NIOSH do not constitute NIOSH endorsement of the sponsoring organizations or their programs or products. Furthermore, NIOSH is not responsible for the content of these websites. All web addresses referenced in this document were accessible as of the publication date.

REAGENTS:

1. Methanol, HPLC grade.
2. Acetonitrile, HPLC grade.
3. Triethylamine.
4. Water, distilled, deionized.
5. Benzidine.*
6. 3,3'-Dichlorobenzidine.*
7. Eluent: 0.17% (v/v) triethylamine in methanol. Dilute 170 µL triethylamine to 100 mL with methanol.
8. Calibration stock solution, 0.5 µg/µL. Dissolve 50 mg analyte in 100 mL eluent.
9. Recovery (R) stock solution, 0.5 µg/µL. Dissolve 50 mg analyte in 100 mL methanol.

*See SPECIAL PRECAUTIONS.

EQUIPMENT:

1. Sampler: 13-mm, Type AE, glass fiber filter in a 13-mm filter holder.
2. Personal sampling pump, 0.2 L/min, with flexible connecting tubing.
3. High-performance liquid chromatograph, UV detector, integrator and column (page 5509-1).
4. Test tubes, 1-mL, with polyethylene stoppers.
5. Syringes, glass, 10- and 25-µL, readable to 0.1 µL.
6. Pipets, delivery, 0.5- and 5-mL, graduated in 0.1 mL.
7. Flasks, volumetric, 10- and 100-mL.
8. Centrifuge.
9. Test tube shaker, vortex type.

SPECIAL PRECAUTIONS: Benzidine is a recognized human carcinogen and can be absorbed through the skin [4,5,6]. 3,3'-Dichlorobenzidine is a carcinogen [4,6]. Take appropriate precautions to avoid personal and area contamination.

SAMPLING:

1. Calibrate each personal sampling pump with a representative sampler in line.
2. Sample at 0.2 L/min for a total sample size of 20 to 100 L.
3. Cap the sampler.
4. Ship and store samples at -15 °C if benzidine may be present.
NOTE: Samples may be stored at room temperature if only 3,3'-dichlorobenzidine is present.

SAMPLE PREPARATION:

5. Place glass fiber filter in a test tube.
6. Add 0.5 mL eluent to each test tube. Seal each test tube and shake them on a test tube shaker.
7. Allow samples to stand for 1 h with intermittent shaking.
8. Centrifuge each sample for 10 min.

CALIBRATION AND QUALITY CONTROL:

9. Calibrate daily with at least six working standards over the range 0.05 to 7 µg analyte per sample.
 - a. Deliver aliquots of calibration stock solution with microliter syringe to eluent in 10-mL volumetric flasks and dilute to the mark.
 - b. Analyze together with the samples and blanks (steps 12 through 14).
 - c. Prepare calibration graph (peak area vs. µg analyte).
10. Determine recovery (R) at least once per year for each lot of filters. Prepare four filters at each of five levels, plus three media blank filters.
 - a. Place sample filters into separate test tubes.
 - b. Inject an aliquot of R stock solution, or a dilution thereof in methanol, directly onto the filter.
 - c. Cap the test tubes. Allow to stand overnight.
 - d. Prepare (steps 5 through 8) and analyze (steps 12 through 14) with working standards.
 - e. Prepare a graph of R for each filter vs. µg analyte recovered.

11. Analyze three quality control blind spikes and three analyst spikes to ensure that the calibration and R graphs are in control.

MEASUREMENT:

12. Set the liquid chromatograph to conditions given on page 5509-1 for analyte of interest.
NOTE 1: If aniline is present, use a C18 column and follow the procedures found in reference [2].
NOTE 2: The following compounds were found not to interfere with the determination of either compound: *o*-, *p*- and *m*-chloroaniline; 4,4'-methylenedianiline and β -naphthylamine. 2-Chloro-4-methylaniline; 3,3'-dichlorobenzidine; 4,4'-methylenebis(2-chloroaniline); hydrazobenzene; and 1,2- and 1,4-naphthoquinone do not interfere in the determination of benzidine. Benzidine, aniline, *N*-methylaniline, 2-toluidine and 3,3'-dimethylbenzidine will not interfere in the determination of 3,3'-dichlorobenzidine [1].
13. Inject an aliquot (see page 5509-1 for appropriate size).
14. Measure peak area.

CALCULATIONS:

15. Read the mass, μg (corrected for R), of analyte found on the sample filter (W) and on the media blank filter (B) from the calibration graph.
16. Calculate concentration, C, of analyte in the air volume sampled, V (L):

$$C = \frac{W - B}{V}, \text{mg}/\text{m}^3$$

EVALUATION OF METHOD:

This method was evaluated over the range 21 to 63 $\mu\text{g}/\text{m}^3$ for benzidine and the range 20 to 130 $\mu\text{g}/\text{m}^3$ for 3,3'-dichlorobenzidine. The generated atmospheres for both compounds were at 30 °C and 80% relative humidity. The sampling rate was 0.8 L/min. The pooled overall precision ($\hat{S}_{r,T}$) was 0.07 for 29 benzidine samples and 0.07 for 28 3,3'-dichlorobenzidine samples. The sampling methods were evaluated for effects of temperature (25, 30, and 35 °C) and relative humidity (20 and 80%). No detectable quantities of either benzidine or 3,3'-dichlorobenzidine were found on backup silica gel tubes [1]. At 180 °C, vapors of these carried by a stream of dry nitrogen at 0.3 L/min did not break through the backup silica gel in 3 h [1].

The average recovery of benzidine from filters was determined to be 97% over the range 0.2 to 2.0 μg when stored at -15 °C for 11 days. Recoveries dropped to 89% and 75% after 15 days and 21 days, respectively. Recoveries of benzidine and benzidinium sulfate from filters and silica gel indicated that the compounds were unstable in these matrices at ambient temperature. Recoveries over the range of 0.5 to 5 μg 3,3'-dichlorobenzidine and its dihydrochloride were 96% after 21 days from both filters and silica gel stored at -15 °C and at ambient temperature [1].

REFERENCES:

- [1] Morales R, Rappaport SM, Weeks, Jr. RW, Campbell EE, Ettinger HJ [1977]. Development of sampling and analytical methods for carcinogens, January 1 - September 30, 1976, Los Alamos Scientific Laboratory, Los Alamos, NM. Available as LA-7058-PR, from NTIS. Unpublished.
- [2] Kennedy ER, Seymour MJ [1981]. Development of an analytical method for benzidine-based dyes. In: Chemical hazards in the Workplace, ACS symposium series: Vol. 149. Washington, DC: American Chemical Society, pp 21-35.

- [3] NIOSH [1977] P&CAM 243 and P&CAM 246. In: Taylor DG, ed. NIOSH manual of analytical methods, 2nd ed. (Vol. 1) Cincinnati, OH: U.S. Department of Health, Education, and Welfare, Centers for Disease Control, National Institute for Occupational Safety and Health, DHEW (NIOSH) Publication No. 77-157-B.
- [4] NIOSH [1980]. NIOSH technical report: carcinogenicity and metabolism of azo dyes, especially those derived from benzidine. Cincinnati, OH: U.S. Department of Health and Human Services, Centers for Disease Control, National Institute for Occupational Safety and Health.
- [5] NIOSH/NCI [1978]. Current intelligence bulletin 24: Direct Blue 6, Direct Black 38, and Direct Brown 95 benzidine-derived dyes. Cincinnati, OH: U.S. Department of Health, Education, and Welfare, Center for Disease Control, National Institute for Occupational Safety and Health, DHEW (NIOSH) Publication No. 78-148.
- [6] NIOSH [1981]. Occupational health guidelines for chemical hazards. Cincinnati, OH: U.S. Department of Health and Human Services, Centers for Disease Control, National Institute for Occupational Safety and Health, DHHS (NIOSH) Publication No. 81-123.

METHOD REVISED BY:

M. J. Seymour, NIOSH.

Disclaimer: Mention of any company or product does not constitute endorsement by NIOSH. In addition, citations to websites external to NIOSH do not constitute NIOSH endorsement of the sponsoring organizations or their programs or products. Furthermore, NIOSH is not responsible for the content of these websites. All web addresses referenced in this document were accessible as of the publication date.

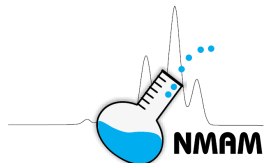

DEFINITION: Metalworking fluids

CAS: None

RTECS: None

METHOD: 5524, Issue 2

EVALUATION: FULL

Issue 1: 15 March 2003

Issue 2: 29 December 2014

OSHA : No PEL
NIOSH: 0.4 mg/m³ as thoracic fraction
 (0.5 mg/m³ as 'total' aerosol)
Other
OELs: [1,2]*

PROPERTIES: Not defined. Fluids may contain varying amounts of mineral oil, emulsifiers, water, alkanolamines, polyethoxyethanols, biocides, surfactants, pressure additives and boron compounds.

SYNONYMS: Metalworking fluids (MWF), metal removal fluids, machining fluids, mineral oils, straight fluids, soluble fluids, synthetic fluids and semi-synthetic fluids

| SAMPLING | | MEASUREMENT | |
|---|---|--|---|
| SAMPLER: | Thoracic particles: FILTER + CYCLONE (tared 37-mm, 2-µm polytetrafluoroethylene (PTFE) filter + thoracic cyclone) Total particulate: tared 37-mm, 2-µm PTFE filter | TECHNIQUE: | Gravimetric |
| FLOW RATE: | Thoracic – 1.6 L/min, Total – 2 L/min | ANALYTE: | Airborne metalworking fluid aerosol |
| VOL-MIN: | 768 L at 0.4 mg/m ³ or 0.5 mg/m ³ | EXTRACTION: | Ternary solvent: dichloromethane: methanol:toluene (1:1:1) Binary solvent: methanol: water (1:1) |
| MAX: | Not determined | BALANCE: | 0.001 mg sensitivity; use same balance before and after sample collection |
| SHIPMENT: | Ship overnight in a refrigerated container | CALIBRATION: | National Institute of Standards and Technology Class S-1.1 weights or ASTM Class 1 weights |
| SAMPLE STABILITY: | Refrigerate upon receipt; analyze within 2 weeks of collection | RANGE: | 0.05 to 2 mg per sample |
| BLANKS: | At least 5 field blanks per set | ESTIMATED LOD: | Total weight - 0.03 mg per sample [3] Extracted weight - 0.03 mg per sample weight [3] |
| BULK SAMPLE: | One for each fluid at each site for solubility testing | PRECISION (\bar{S}_r): | Total weight - 0.04 (≥ 0.2 mg/sample) [4] Extracted weight - 0.05 (≥ 0.2 mg/sample) [4] |
| ACCURACY | | | |
| RANGE STUDIED: | 0.05 to 0.9 mg/sample | | |
| BIAS: | Not determined | | |
| OVERALL PRECISION (\hat{S}_{rr}): | Total weight- 0.06 Extracted weight - 0.07 | | |
| ACCURACY (Estimated): | Total weight - 0.12 Extracted weight - 0.14 | | |

APPLICABILITY: The method is applicable to all metalworking fluids-straight, soluble, synthetic and semi-synthetic as long as they are soluble in the extraction solvent regimen [4,5]. Only one MWF (Glacier, Solutia Inc.) has thus far been found to be insoluble in the ternary extraction solvent; however, that MWF is soluble in the binary blend and tests have shown that the binary solvent in combination with the ternary solvent is effective in extracting this fluid [6]. **Thoracic samplers** meeting the International Standard ISO 7708 thoracic convention within the performance specifications of the European Standard EN13205, parts 1 through 6 [2] may be considered for this method if they have been validated for the collection of MWF. Depending on the type of thoracic sampler used, the recommended flow rate may differ from that specified above. Sampling at flow rates exceeding those recommended here may result in increased evaporative loss of sample. Welding fume may significantly interfere with proper operation of certain impactor-style samplers.

INTERFERENCES: None identified. However, any material that is collected on the filter and is soluble in the extraction solvents may interfere (positively) with the analysis.

OTHER METHODS: This method is similar to NMAM Method 0500 for Particulates Not Otherwise Regulated [7] and replaces NMAM Method 5026 as a general technique for analysis of MWF. NMAM Method 5026, which employs infrared analysis, may be used solely for the analysis of (straight) MWF that produce mineral oil mists; that method is not recommended for use with water-based fluids [8]. ASTM D7049 is another method that may be used to analyze metalworking fluids [9].

REAGENTS:

1. Dichloromethane, distilled-in-glass (DIG) (See Note)[‡]
2. Methanol, distilled-in-glass (See Note)[‡]
3. Toluene, distilled-in-glass (See Note)[‡]
4. Water, filtered, double deionized (18 MΩ·cm resistivity)
5. Calcium sulfate, desiccant
6. Ternary solvent blend[‡]: Mix equal volumes of dichloromethane, methanol and toluene in a clean dust-free container. Use a bottle with a screw cap (e.g., a clean, empty solvent bottle): Mix the solvents by gentle swirling, not by violent shaking.
7. Binary solvent blend[‡]: Mix equal volumes of methanol and water in a clean dust-free container. Use a bottle with a screw cap (e.g., a clean, empty solvent bottle): Mix the solvents by gentle swirling, not by violent shaking.

NOTE: Lower grade solvents have not been evaluated for this method. If it is desired to use ACS or liquid chromatographic grade solvents, in the interest of economy, the user must demonstrate that these solvents perform equally to the DIG grade (blanks \leq those obtained with the DIG grade).

[‡] See SPECIAL PRECAUTIONS

EQUIPMENT:

1. Sampler: 37-mm PTFE, 2- μ m pore size membrane filter (see Appendix 1 for PTFE filter cleanup procedure) and PTFE supporting pad in 37-mm cassette filter holder. Use a 2-piece (closed face) cassette for sampling 'total' aerosol. For sampling the thoracic fraction, use a 3-piece cassette with thoracic cyclone that samples at 1.6 L/min at the thoracic cutpoint. See Evaluation of Method. Also, see page 5524-1 for discussion of alternative thoracic sampling.
2. Personal sampling pump, 1.6 to 2 L/min, with flexible connecting tubing
3. Cassette shrink bands, cellulose, 37-mm size
4. Microbalance, capable of weighing to 0.001mg
5. Static neutralizer: e.g., ²¹⁰Po; replace nine months after the production date
6. Forceps (preferably nylon or chrome-plated steel)
7. Extraction funnel, See Figure 1 for specifications p. 5524-10
8. Desiccator
9. Wash Bottle, PTFE
10. Vials, 20-mL and 10-mL, glass, with leak-proof PTFE-lined caps
11. Syringe, gas-tight with large bore needle, e.g., 16-gauge needle
12. Graduated cylinder, glass, 20 mL
13. Paper towels
14. Metal screen for drying filters following extraction, approximately 550 cm² or other convenient size. Grid size approximately 12 to 18 mm. Pre-wash screen with ternary blend solvent and allow to dry.

SPECIAL PRECAUTIONS: Dichloromethane is an inhalation hazard and is a suspect carcinogen. Handle all solvents in a fume hood. The solvents are flammable and have associated adverse health effects. Avoid breathing vapors. Avoid skin contact. Use extreme caution when blending the solvents together. The heat of mixing can cause pressure to develop as the solvents are blended, e.g., blowing a stopper from a glass-stoppered container. Use clean containers sealed with PTFE-lined screwcaps.

CALIBRATION AND QUALITY CONTROL:

1. Zero the microbalance before all weighings. Use the same microbalance for weighing filters before and after sample collection. Maintain and calibrate the balance with National Institute of Standards and Technology Class S-1.1 or ASTM Class 1 weights.
2. Process at least three tared media blanks through the measurement process for 'total' aerosol and the extractable materials.

PREPARATION OF FILTERS BEFORE SAMPLING:

3. Number the backup pads with indelible ink and place them, numbered side down, in the filter cassette bottom sections.
4. Pre-weigh the filters by the weighing procedure given in step 5. Record the mean tare weight of sample filters, W_1 and field blanks, B_1 (mg).
5. Weighing procedure:
 - a. Equilibrate the filters in an environmentally controlled weighing area or chamber for 1 hour (minimum.)
 - b. Zero the balance before each weighing. Using forceps, pass each filter over a static neutralizer. Repeat this step if the filter does not release easily from the forceps or attracts the balance pan. (Static electricity can cause erroneous weight readings.)
 - c. Weigh each filter until a constant weight is obtained (i.e., two successive weighings within 10 μg .)
 - d. Record the mean of the last two weights to the nearest microgram.
6. Assemble the filter in the 2- or 3-piece filter cassettes and close firmly so that leakage around the filter will not occur. Place a plug in each opening of the filter cassette. Place a cellulose shrink band around the filter cassette and allow to dry. Alternatively, use heavy duty elastic tape instead of the shrink band. Mark with the same number as the backup pad.

SAMPLING:

Bulks: For solubility testing, obtain liquid samples of pure uncut bulk metal-working fluids (MWF) that are expected to be sampled in worker breathing zone. Place these samples in small (e.g., 10 mL) leak-proof glass container(s) that are sealed with a leak-proof PTFE-lined screwcap. Then place them inside of a resealable plastic bag and ship these samples to the laboratory along with the sample filter cassettes.

Air: For collection of a thoracic sample, insert the cyclone into the inlet of a 3-piece cassette. For collection of a "total" sample, do not use the cyclone.

7. Calibrate each personal sampling pump with a representative sampler in line.
8. For thoracic measurements, sample at 1.6 L/min for 8 hours. For 'total' aerosol measurements, sample at 2 L/min for 8 hours. Do not exceed a total filter loading of approximately 2 mg.
9. Submit at least 5 blank filter samples as field blanks and 3 filters for media blanks for each set of samples collected per day. Handle the field blanks in the same way as the field samples; i.e., open each in a non-contaminated environment, then close the sampler and ship it to the lab along with the remaining samples. Media blanks are not opened.
10. Refrigerate all samples that are to be stored overnight (or longer) prior to shipment to the laboratory. Ship all samples in refrigerated containers to the laboratory via overnight express delivery service.
11. Refrigerate the samples immediately upon receipt at the lab until ready for analysis.
12. Analyze the samples within two weeks of receipt at the laboratory.

SAMPLE PREPARATION AND MEASUREMENT:

13. Solubility test of bulk MWF:
 - a. Shake the container of bulk MWF to ensure that a homogeneous sample is obtained.
 - b. Place 10 mL of the ternary solvent blend in a 20-mL glass vial.
 - c. Using a large-bore gas-tight syringe, inject 50 μL of the bulk MWF into the ternary solvent blend. Cap the vial and shake as necessary to dissolve the MWF. The fluid is soluble if the resulting solution is clear and free of precipitates and phase separation.
 - d. If the MWF is soluble in the ternary blend, the samples can be extracted with the ternary blend.
14. Wipe dust from the external surface of each filter cassette (containing either samples or blanks) with a moist paper towel to minimize contamination. Discard the paper towel.
15. Remove the top and bottom plugs from the filter cassette. Equilibrate the filters (in the cassettes) for no more than 2 hours in a desiccator that uses calcium sulfate.
16. Remove from the desiccator. Equilibrate for at least 1 hour in the balance room or chamber.
17. Remove the cassette band, pry open the cassette, and remove the filter gently to avoid loss of sample.

NOTE: If the filter adheres to the underside of the cassette top, very gently lift it away by using the dull side of a scalpel blade. This must be done carefully or the filter will tear.
18. Weigh and record (steps 5b through 5d) the post-sampling weight of each filter, W_2 (mg) and blank, B_2 (mg). Record anything remarkable about the filter (e.g., overload, leakage, wet, or torn). Perform the extraction as soon as possible. Store in a clean dust free environment until ready to perform the extraction, etc.

EXTRACTION:

19. Perform all extractions in an exhaust hood. General guidelines (see NOTE below):

NOTE: Samples weighing less than 0.4 to 0.5 mg (for a 1 m^3 sample) may be extracted as desired. The reason that the cutoffs of 0.4 and 0.5 mg (per 1000 L sample) have been specified is to assure compliance with the occupational exposure limit (OEL). If the gross sample weight indicates that the OEL has not been exceeded, there may be no reason to extract the sample. Otherwise, the usefulness of any extraction data obtained at levels less than 0.4 to 0.5 mg per sample is guided by the limit of quantitation (LOQ) of the extraction procedure. Extraction data obtained at levels between the limit of detection (LOD) and the LOQ of the extraction procedure should be used with appropriate caution due to the imprecision associated with such data.
20. Do not presume that a fluid that is soluble only in the binary-blend should be extracted using only the binary blend. The possibility of mixed exposures always dictates that the extraction procedure with both the binary and ternary solvent blends should be followed. If the weights of samples exceed the amount expected to be collected at the REL, e.g., 0.4 mg (thoracic fraction) or 0.5 mg ('total' aerosol) for a 1 m^3 air sample, then extract the samples and blanks as follows:
 - a. Place each filter (membrane side up) in the filter funnel assembly connected to the vacuum source.
 - b. Pour one 10-mL aliquot of the *ternary solvent* down the inside wall of the funnel over the filter. Allow the solvent to contact the filter for no more than 5 to 10 minutes. Remove the solvent under slight vacuum.
 - c. Pour one 10-mL aliquot of the *binary solvent* down the inside of the funnel over the filter. Allow the solvent to contact the filter for no more than 5 to 10 minutes. Remove the solvent under slight vacuum.
 - d. Pour a second 10-mL aliquot of the *ternary solvent* down the inside of the funnel over the filter. Allow at least 30 seconds of contact time. Remove the solvent under slight vacuum. Wash the inner wall of the filter funnel with 1 to 2 mL of the ternary blend contained in a PTFE wash bottle. Remove the solvent under slight vacuum.

- e. Turn off the vacuum to the filter funnel.
- f. Carefully remove the filter from the filter funnel, place it on the clean metal screen, and allow to dry on the metal screen for at least 2 hours in a fume hood. Do not remove the filter from the funnel while vacuum is applied or the filter may delaminate.

NOTE: One metalworking fluid, Glacier (Solutia Chemical, St Louis), was insoluble in the ternary blend but was soluble in the binary blend. Tests have shown that this fluid is extracted efficiently from the filters using steps 20a through 20e [5].

21. Weigh each filter, including field blanks, following steps 5a through 5d. Record the post-extraction weight, W_3 (mg), of the extracted sample filters and B_3 (mg), for the extracted blank filters. Record anything remarkable about the extracted filter (e.g., torn, wet, delamination, etc.).

CALCULATIONS:

22. Calculate the concentration of 'total' aerosol or thoracic fraction, C (mg/m^3), in the air volume sampled, V (L):

$$C = \frac{(W_2 - W_1) - (B_2 - B_1) * 10^3 \text{ L} / \text{m}^3}{V}, (\text{mg} / \text{m}^3)$$

where:

- W_1 = mean tare weight of filter before sampling (mg) (step 5)
- W_2 = mean post-sampling weight of sample-containing filter (mg) (step 18)
- B_1 = mean tare weight of all blank filters (mg) (step 5)
- B_2 = mean post-sampling weight of all blank filters (mg) (step 18)

23. Calculate the concentration of extracted MWF aerosol C_{MWF} (mg/m^3), in the air volume sampled, V (L):

$$C_{\text{MWF}} = \frac{(W_2 - W_3) - (B_2 - B_3) * 10^3 \text{ L} / \text{m}^3}{V}, (\text{mg} / \text{m}^3)$$

where:

- W_2 = mean post-sampling weight (pre-extraction weight) of sample-containing filter (mg) (step 18)
- W_3 = mean post-extraction weight of sample-containing filter (mg) (step 21)
- B_2 = mean post-sampling weight of all blank filters (mg) (step 18)
- B_3 = mean post-extraction weight of all blank filters (mg) (step 21)

24. Report the concentration C as 'total' aerosol or thoracic fraction weight; report the concentration C_{MWF} as the weight of the MWF aerosol.

EVALUATION OF METHOD:

The 'total' weight procedure permits an estimate of the 'total' collected particulate aerosol, including nuisance dust, airborne metal particulate and metal working fluid. If the extraction procedure is used, the technique permits an estimate of the 'total' collected metalworking fluid to which the worker is exposed. The development of the ternary solvent used in this method is described in reference 3. This method was initially tested with representative samples of straight, soluble, semi-synthetic, and synthetic metalworking fluids (MWFs). Samples were spiked onto tared polytetrafluoroethylene (PTFE) membrane filters, stored overnight, and analyzed the following day. The samples were weighed, then the MWF was extracted from the filter with a 1:1:1 blend of dichloromethane:methanol:toluene. The fractions extracted (FE or mass recovered/mass spiked) exceeded 94% for all fluids extracted from the filters over the range from 200 μg to 815 μg for the straight fluid, from 223 μg to 878 μg for the soluble

fluid, from 51 µg to 189 µg for the semi-synthetic fluid, and from 102 µg to 420 µg for the synthetic fluid. For those weights of all four fluids spiked at levels ≥ 200 µg, the relative standard deviation was estimated to be 4% for the total weight procedure and 5% for the extraction procedure. If the sampling imprecision of 5% is included, these estimates become 6% and 7% respectively for the total weight and extraction procedures. Limits of quantitation, estimated from blanks carried through the entire analytical procedure, were 30 µg for the weighing technique and 60 µg for the extraction technique. No estimate of the bias was available [4]. The filters are desiccated to remove excess water from water-based MWF samples.

In a more rigorous test of this method for a 79-plant survey [2], the average limits of quantitation were estimated to be 0.1 mg for both the total and extracted weight procedures. However, there was high variability in these estimates for the sites sampled. The upper 95% confidence limit for the LOQs for both the total weight and extracted weight measurements was 0.3 mg. In order to assess the effectiveness of the extraction step, a secondary extraction of the most heavily-loaded filters obtained in this survey was conducted; on average, less than 5% of the sample weight was removed during the second extraction, indicating that the majority of extractable material had been removed during the first extraction. Samples were refrigerated upon receipt at the laboratory [2,10].

During the 79-plant survey, all thoracic sampling was conducted with a BGI Mdl 2.69 Thoracic sampler. This sampler has a thoracic cut point of 10 µm at 1.6 L/min. The stability of quality assurance (QA) samples, spiked separately with a straight, a soluble, a semi-synthetic, and a synthetic fluid, indicated that the QA samples all lost weight according to simple linear decay equations. This loss in weight was likely due to evaporation of the spiking solvent and water (for soluble, semi-synthetic and synthetic MW fluids.) These decay equations were used to estimate the amounts expected to be reported for QA filters by the performing laboratory. For storage periods ranging from 17 to 26 days, the total weight of samples recovered for all QA samples were greater than or equal to 80% of those expected from the decay equations. For these QA samples, the fractions extracted of all four fluid types were greater than or equal to 90%.

The binary solvent extraction step has been added to assure complete extraction of MWF components that may be incompletely removed by the ternary blend. In addition, the binary solvent extends the procedure to samples that contain ternary blend-soluble fluids co-mingled with ternary blend-insoluble fluids, e.g., Glacier (Solutia Inc). Tests of the extraction of five MWF (including Glacier) showed that extraction efficiencies using the ternary blend in combination with the binary blend were comparable to those reported in reference 1 using the ternary blend alone (FE greater than 90 %; CV less than 0.10). The binary solvent extractant liquor obtained from the Glacier samples generally contained potassium and phosphorous at levels approximately expected for the mass spiked onto the filters. The binary solvent extracts of the four other test fluids were analyzed for sodium, potassium or boron marker elements. Sodium was present in the extract of the soluble fluid at greater than background levels. The boron marker was not detected in the extract from the semi-synthetic fluid. The potassium marker was not detected in the extract from the synthetic fluid [5].

This method was further evaluated in a six-laboratory round robin study using synthetically generated atmospheres of an aerosol of a soluble MWF at the 0.5 mg/sample level. The data were evaluated according to ASTM standard E691-99. Pooled estimates of the total coefficients of variation were 0.13 for both the total and extracted weight samples. Overall there was no significant bias in the results. LOQs were comparable to those reported above [11].

REFERENCES:

- [1] Health and Safety Executive (HSE), United Kingdom [2003]. MDHS 95/2, Measurement of personal exposure of metalworking machine operators to airborne water-mix metalworking fluid. [<http://www.hse.gov.uk/pubns/mdhs/pdfs/mdhs95-2.pdf>] Website accessed March 25, 2013.

- [2] BSI (British Standards Institute) [2014]. BS EN 13205:2014. Workplace exposure. Assessment of sampler performance for measurement of airborne particle concentrations. Parts 1 through 6. Brussels, Belgium: European Committee for Standardization.
- [3] Glaser RA, Shulman S, Kurimo R, Piacitelli G [2002]. Data supporting a provisional American Society for Testing and Materials (ASTM) Method for metalworking fluids, Part 3: evaluation of a provisional ASTM Method for metalworking fluids in a survey of metalworking facilities. *Journal of Testing and Evaluation* 20(5): 439-451.
- [4] Glaser RA, Shulman S, Klinger P [1999]. Data supporting a provisional American Society for Testing and Materials (ASTM) Method for metalworking fluids, Part 2: preliminary report of evaluation of a ternary extraction solvent in a provisional ASTM Test Method for metalworking fluids (PS-42-97). *Journal of Testing and Evaluation* 17(3):131-136.
- [5] Glaser RA [1999]. Data supporting a provisional American Society for Testing and Materials (ASTM) Method for metalworking fluids, Part 1: a solvent blend with wide-ranging ability to dissolve metalworking fluids. *Journal of Testing and Evaluation* 17(3):171-174.
- [6] Glaser RA, Kurimo R, Neumeister C, Shulman S [2005]. Data supporting ASTM Method D7049-04 for determination of metalworking fluids, *ASTM Journal of Testing and Evaluation*, 33(5):323-330.
- [7] NIOSH [1994]. Particulates not otherwise regulated: Method 0500. In: Eller PM, Cassinelli ME, eds. *NIOSH Manual of Analytical Methods*, 4th ed. Cincinnati OH: U. S. Department of Health and Human Services, Centers for Disease Control and Prevention, National Institute for Occupational Safety and Health, DHHS (NIOSH) Publication No. 94-113. [www.cdc.gov/niosh/nmam/].
- [8] NIOSH [1994]. Oil Mist, Mineral: Method 5026. In: Eller PM, Cassinelli ME, eds. *NIOSH Manual of Analytical Methods*, 4th ed. Cincinnati OH: U. S. Department of Health and Human Services, Centers for Disease Control and Prevention, National Institute for Occupational Safety and Health, DHHS (NIOSH) Publication No. 94-113. [www.cdc.gov/niosh/nmam/].
- [9] ASTM D7049 [2010]. Standard Test Method for Metal Removal Fluid Aerosol in Workplace Atmospheres. ASTM International, West Conshohocken, PA.
- [10] Piacitelli G, Hughes R, Catalano J, Sieber W, Glaser RA, Kent M [1997]. Exposures to Metalworking fluids in small size machine shops. Presented at The Industrial Metalworking Environment: Assessment and Control of Metal Removal Fluids Symposium, Detroit, Michigan, September 1997.
- [11] Glaser RA, Kurimo R, Shulman S [2007]. Performance testing of NIOSH Method 5524/ASTM method D-7049-04 for determination of metalworking fluids. *J Occup Environ Hyg*, 4:583-595.

METHOD WRITTEN BY:

R. Glaser, NIOSH/DART and edited by Y.T. Gagnon, NIOSH/DART.

Disclaimer: Mention of any company or product does not constitute endorsement by NIOSH. In addition, citations to websites external to NIOSH do not constitute NIOSH endorsement of the sponsoring organizations or their programs or products. Furthermore, NIOSH is not responsible for the content of these websites. All web addresses referenced in this document were accessible as of the publication date.

* NOTE: Because exposure limits and guidelines may change over time, NIOSH recommends referring to the following sources for updated limits and guidelines. [1,2]

Appendix 1. Procedure to remove PTFE filter contaminants that are soluble in and extracted with the ternary blend.

Use this procedure to prevent high blanks from being obtained following extraction of PTFE filters. The filters are rinsed with ternary solvent (1:1:1 dichloromethane:methanol:toluene) described in NMAM Method 5524. The filters are air-dried and protected from airborne contamination prior to weighing and assembly into cassettes for field sampling. See evaluation of procedure which follows these instructions.

EQUIPMENT, SUPPLIES, REAGENTS AND STANDARDS

1. 250 mL glass beaker(s)
2. 500 mL of ternary solvent 1:1:1 ratio of dichloromethane:methanol:toluene in a stoppered container
3. A fume hood
4. Watch glasses to fit the beakers
5. Glass stir rod
6. One box (or as many as required) of 2 micron PTFE filters to be cleaned; recommend cleaning no more than 1 package of 50 filters per 100 mL of solvent
7. Stainless steel forceps to manipulate filters
8. Large, lint-free paper towels
9. Clean, stainless steel metal trays or screen approximately 45 cm x 60 cm (18 inch x 24 inch)
10. Nitrile gloves
11. Clean, wide mouth glass container e.g., ointment jar with Teflon cap or French square bottle

PROCEDURE

Perform all of the following tasks inside a fume hood!

1. Wear nitrile gloves throughout this procedure to protect yourself from the solvent and to protect the filters from skin oil during handling.
2. Pour approximately 100 mL of ternary solvent into a 250 mL glass beaker.
3. Remove the PTFE filters from the package and remove the plastic spacers from between the filters. Place the filters individually (sample side up) into the beaker filled with ternary solvent. Be careful that the filters stay separated from each other and do not clump together.
4. Carefully stir the filters with the glass stir rod; do not allow the filters to turn over. Cover the beaker with the watchglass. Allow the filters to extract in the solvent in the beaker for 10 minutes.
5. Decant the ternary solvent out of the beaker and into a waste bottle. Use the stirring rod to compress and retain the filters in the beaker as the solvent is slowly decanted off.
6. Refill the beaker with 100 mL of fresh ternary solvent after decanting following step 5. Repeat steps 4 and 5, two times for a total of three solvent washes.
7. After the three rinses are complete, drain off as much solvent as possible. Remove the filters from the beaker using forceps and place them onto a clean stainless steel metal tray that has been covered with a large, lint-free paper towel. Alternatively, place them on a clean stainless steel screen. Place them onto the tray or screen, sampling side up. Allow the filters to dry overnight.
Warning: Keep the hood sash approximately at or below the sash height level as marked on the hood. If the sash is pushed lower, the higher air flow may blow the filters off the drying tray or screen. Place a sign on the sash indicating that it is to be left at this height overnight and **not to be moved**.
8. Place the dried filters in a clean French square glass bottle or a wide-mouthed Teflon™ capped ointment jar. Label the container "PTFE 2-µm filters rinsed with MWF solution," giving the date, initials, and number of filters. Do not store filters in plastic containers. Filters are now ready to be used for sampling. Since the filters are not separated by spacers, use care to remove them from the storage container for use.

Cleanup Procedure Evaluation

This cleanup procedure has been incorporated into NMAM Method 5524 in order to deal with reported spurious weight gains and losses before and after analysis of the PTFE filters used with this method. It is believed that trace levels of dust or extractable material are entrained in these filters during the manufacturing process. This cleanup procedure has been evaluated using 60 filters from three different batches of PTFE filters (20 filters/batch) [1]. Prior to cleaning, the filters were weighed (**untreated filters**), then washed with the ternary blend according to the procedure in Appendix 1, dried, and then reweighed (**treated filters**).

Results: The differences in each of the 3 batches were compared by subtracting the **treated** filter weights from their **untreated** weights. For all 60 samples, the overall mean difference in weights (+/-the standard error of the mean) was 0.2 μg ($\pm 1.4 \mu\text{g}$). For each of the 3 batches, the differences in weight were reported as mean (+/-standard error): 5 μg ($\pm 2.5 \mu\text{g}$), -2 μg ($\pm 2.0 \mu\text{g}$), and -3 μg ($\pm 2.7 \mu\text{g}$) for batches 1, 2 and 3, respectively. The weight differences were not statistically significant from zero overall or by batch using a paired t-test ($p = 0.05$), and allowing for multiple comparisons.

To determine if the washing procedure affected the filter's performance for analysis of metalworking fluids, each of the filters was analyzed according to the procedure of NMAM Method 5524, which includes extraction with the binary and ternary solvent blends. The following differences were computed: **post-analysis** weights of the filters minus their **treated** or **untreated** weights. The average difference in the weights of the 60 **untreated** filters and their **post-analysis** weights reported as mean (\pm standard error of the mean) was 34 μg ($\pm 1.9 \mu\text{g}$). For each of the 3 batches, the differences in the **untreated** and **post-analysis** weights were: 30 μg ($\pm 3.9 \mu\text{g}$), 38 μg ($\pm 2.0 \mu\text{g}$) and 34 μg ($\pm 3.3 \mu\text{g}$) for batches 1, 2 and 3, respectively. These differences are statistically significantly different from zero, both overall and individually by batch, using a paired t-test ($p = 0.05$), and allowing for multiple comparisons.

The average differences in the weights of the 60 **treated** filters and their **post-analysis** weights were: 34 μg ($\pm 1.4 \mu\text{g}$). Again the differences in weight are reported as mean (\pm standard error). For each of the 3 batches, the differences, (**post-analysis minus treated**) weights, were: 35 μg ($\pm 3.4 \mu\text{g}$), 36 μg ($\pm 2.0 \mu\text{g}$), and 31 μg ($\pm 1.8 \mu\text{g}$) for batches 1, 2 and 3, respectively. These differences are statistically significantly different from zero, both overall and individually by batch, using a paired t-test ($p = 0.05$), and allowing for multiple comparisons.

In summary, the weight differences were statistically different from zero by batch and overall using a paired t-test for both the **post-analysis minus treated** weights and for the **post analysis-untreated** weights ($p = 0.05$). However, the untreated/treated differences were not statistically different using the same tests.

These experiments indicate that cleaning the filters lowered the overall LOQ of the analytical method. The LOQ determined from the differences in weights between the **untreated** and **analyzed** filters was 140 μg and was greater than the LOQ of 110 μg determined from the differences in weights between the **treated** and **analyzed** filters. The extraction procedure produced a more consistent blank and therefore a lower average standard deviation from which lower LODs and LOQs were determined.

[1] NIOSH [2014]. CEMB Analytical Services Report: Sequence 11600-CA. Novi, MI: Bureau Veritas North America, unpublished.

Figure 1. Schematic diagram of funnel. May be ordered from Case Custom Environmental Equipment, Erlanger, Kentucky (859-250-8558); www.casecustomenvironmentalequipment.com) or equivalent source. Dimensions are given in inches.

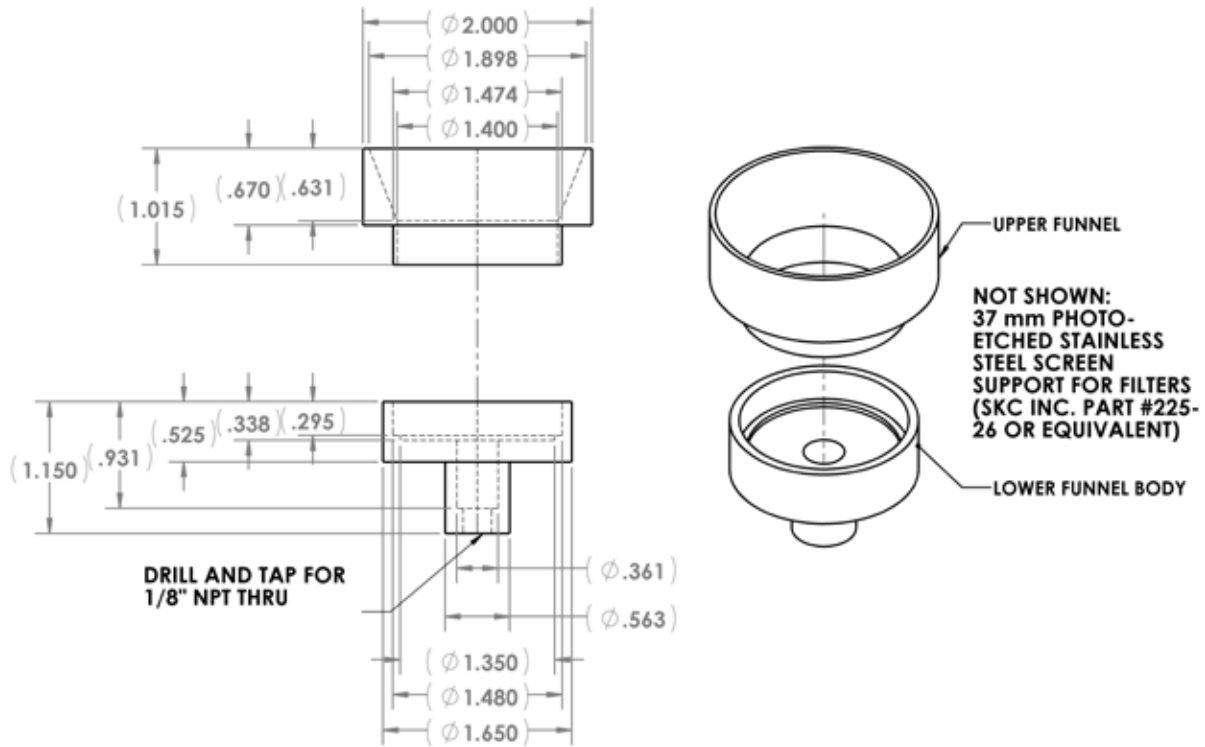

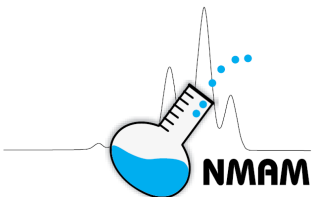

Formula: Table 1 MW: Table 1 CAS: Table 1 RTECS: Table 1

METHOD: 5526, Issue 2

EVALUATION: FULL

Issue 1: 15 March 2003
Issue 2: 13 January 2016

OSHA: See Table 1
NIOSH: See Table 1

PROPERTIES: See Table 1

SYNONYMS: Methyltin trichloride: monomethyltin trichloride, trichloromethylstannane
Dimethyltin dichloride: dichlorodimethylstannane, dichlorodimethyltin
Trimethyltin chloride: chlorotrimethylstannane, chlorotrimethyltin, trimethylstannyl chloride

| SAMPLING | MEASUREMENT |
|---|--|
| <p>SAMPLER: FILTER + SORBENT TUBE (OVS-2 tube: 13 mm glass fiber filter; XAD-2, 270 mg/140 mg)</p> <p>FLOW RATE: 0.25 L/min to 1 L/min</p> <p>VOL-MIN: 15 L -MAX: 75 L</p> <p>SHIPMENT: Ship assembled sampler cold</p> <p>SAMPLE STABILITY: 14 d @ 4 °C</p> <p>FIELD BLANKS: 2 to 10 field blanks per set</p> | <p>TECHNIQUE: GAS CHROMATOGRAPHY, FPD (tin-specific filter)</p> <p>ANALYTE: Sodium tetraethylborate derivatives of the analytes</p> <p>DESORPTION: 2 mL 0.17 mol/L acetic acid in acetonitrile</p> <p>INJECTION: 1 µL</p> <p>TEMPERATURE-INJECTOR: Cool on-column -DETECTOR: 250 °C -COLUMN: 50 °C (3 min), 12 °C/min to 200 °C (1 min)</p> <p>CARRIER GAS: Helium, 6 mL/min</p> |
| ACCURACY | <p>COLUMN: Capillary, fused silica, 30 m × 0.53 mm ID, 1.5 µm film, (5% phenyl)-methylpolysiloxane; US Pharmacopeia (USP) G27</p> <p>CALIBRATION: Analytes in hexane</p> <p>RANGE: 0.01 µg to 15 µg per sample (as tin) [2]</p> <p>ESTIMATED LOD: 0.01 µg [2]</p> <p>PRECISION (\bar{S}): 0.065 [2]</p> |
| <p>RANGE STUDIED: Table 2</p> <p>BIAS: Table 2</p> <p>OVERALL PRECISION (\hat{S}_{rr}): Table 2</p> <p>ACCURACY: Table 2</p> | |

APPLICABILITY: This method was developed for air monitoring of methyltin chlorides [2].

INTERFERENCES: None were identified.

OTHER METHODS: NIOSH method 5504 is another method for the measurement of organotin compounds using a filter with a sorbent tube for collection and HPLC/AA for analysis [3].

REAGENTS:

1. Acetic acid, 99+%.*
2. Acetonitrile, HPLC grade.*
3. Diethyl ether, 99+%.*
4. Hexane, HPLC grade*.
5. Methyltin trichloride, 97%.
6. Dimethyltin dichloride, 97%.
7. Trimethyltin chloride.
8. Acetic acid, 0.17 mol/L in acetonitrile. Dilute 1.00 mL of glacial acetic acid to 100 mL with acetonitrile.
9. Sodium tetraethylborate.*
NOTE: Purity of sodium tetraethylborate is critical. It should appear as a fine white powder. Clumping or yellowing indicates that the compound must be replaced.
10. Sodium acetate-acetic acid buffer, pH 4.0 ± 0.2 .
11. Derivatizing solution: Prepare a solution containing 10 g/L of sodium tetraethylborate in diethyl ether. Prepare the solution fresh daily, preferably immediately before use.
12. Calibration stock solution: Prepare a stock calibration solution by accurately weighing (to ± 0.1 mg) about 0.1 g each of methyltin trichloride, dimethyltin dichloride, and trimethyltin chloride into a 50 mL volumetric flask. Dilute to volume with 0.17 mol/L acetic acid in acetonitrile. The stock solution contains about 1000 $\mu\text{g/mL}$ (as tin) of each component. Stored in a freezer, this solution remains stable for several weeks.

*See SPECIAL PRECAUTIONS.

EQUIPMENT:

1. Sampler: OSHA versatile sampler (OVS-2 tube), 13 mm OD inlet, 6 mm OD outlet. Front section contains 270 mg 20/60 mesh XAD-2 sorbent held in place by an 11 mm diameter glass fiber filter and PTFE ring, separated from the back section of 140 mg XAD-2 sorbent by a short plug of polyurethane foam. The back section is held in place with a long plug of polyurethane foam. The tube is available commercially.
2. Personal sampling pump: 0.1 L/min to 1 L/min with flexible and inert connecting tubing.
3. Gas chromatograph equipped with a cool on-column injection port, automated injector, capillary column, flame-photometric detector (FPD) with a tin-specific filter (610 nm), and data collection system (page 5526-1).
4. Balance capable of weighing to ± 0.1 mg.
5. Mechanical shaker.
6. Vials, 10 mL, with PTFE-lined screwcaps.
7. Transfer pipettes or eyedroppers.
8. GC autosampler vials with PTFE-lined caps.
9. Volumetric flasks, 5 mL, 10 mL, and 50 mL.
10. Pipettes capable of accurately delivering 10 μL , 1.0 mL, and 2.0 mL.
11. Refrigerant packs for shipping.

SPECIAL PRECAUTIONS: Concentrated acetic acid is corrosive and an irritant. Sodium tetraethylborate is sensitive to air and moisture. This chemical should be stored and handled under a nitrogen atmosphere. Acetonitrile, diethyl ether, and hexane are all flammable. Wear appropriate protective clothing and work with these compounds in a well-ventilated hood.

SAMPLING:

1. Calibrate each personal sampling pump with a representative sampler in line.
2. Uncap the sorbent tube immediately before sampling and connect to a personal sampling pump with flexible tubing.
3. Sample at an accurately known flow rate between 0.25 L/min for full shift sampling and 1 L/min for 15 min samples (STEL) for a maximum of 75 L.
4. Cap the samplers. Pack securely for shipment with cold refrigerant packs.
NOTE: After receipt at the laboratory, samples should be stored at 4 °C and analyzed within 14 d of collection.

SAMPLE PREPARATION:

5. Remove the retaining ring from the sorbent tube and discard. Transfer the glass fiber filter and the main resin bed to a 10 mL sample vial.
6. Remove and discard the foam plug that separates the two resin sections in the sorbent tube. Transfer the backup resin bed to a second 10 mL sample vial.
7. Into each vial, add 2 mL of 0.17 mol/L acetic acid in acetonitrile to desorb the methyltin chlorides. Put the vials on a mechanical shaker for 30 min.
8. Into each vial, add 2 mL of pH 4 buffer and 1 mL of derivatizing solution. Place the vials on the mechanical shaker for 15 min.
9. Extract the solution with three 1 mL portions of hexane. Combine the hexane fractions in a 5 mL volumetric flask and dilute to volume with hexane.

CALIBRATION AND QUALITY CONTROL:

10. Calibrate daily with at least six working standards over the range of interest.
 - a. Accurately pipette 10 μ L of the calibration stock solution into a vial that contains 5 mL of 0.17 mol/L acetic acid in acetonitrile. Derivatize like a sample following steps 7, 8, and 9.
 - b. Serially dilute this standard derivatized solution with hexane to produce solutions over the range of 0.2 μ g/mL to 0.02 μ g/mL (as tin) of each methyltin chloride.
 - c. Transfer to autosampler vials with PTFE-lined caps.
 - d. Analyze together with samples and blanks (steps 13, 14, and 15).
 - e. Prepare calibration graph (peak areas vs. μ g tin for each methyltin chloride).
11. Determine desorption efficiency (DE) at least once for each lot of OVS tubes used for sampling in the calibration range (step 10). Prepare three samplers at each of six levels plus three media blanks.
 - a. Transfer the front sorbent section of the OVS sampler to a 4 mL vial.
 - b. Inject a known volume of calibration stock solution, or serial dilution, directly onto the front sorbent bed of each OVS tube.
 - c. Cap vial and allow spiked sorbent bed to stand overnight.
 - d. Desorb (steps 7, 8, and 9) and analyze together with standards and blanks (steps 13, 14, and 15).
 - e. Prepare a graph of DE vs. μ g for each methyltin chloride recovered.
12. Analyze three quality control blind spikes and three analyst spikes to ensure that the calibration graph and DE graphs are in control.

MEASUREMENT:

13. Set gas chromatograph according to manufacturer's recommendations and to conditions given on page 5526-1.
14. Inject a 1 μ L sample aliquot manually using solvent flush technique or with an autosampler.
NOTE: If peak area is above the linear range of the working standards, dilute with hexane, reanalyze, and apply the appropriate dilution factor in the calculations.
15. Measure the areas of the peaks of the methyltin chlorides. A sample chromatogram is shown in Figure 1.

CALCULATIONS:

16. Determine the mass, μ g (corrected for DE), for each methyltin chloride found in the sample front (W_f) and back (W_b) sorbent sections, and in the average media blank front (B_f) and back (B_b) sorbent sections.
NOTE: If $W_f > W_b / 10$, report breakthrough and possible sample loss.
17. Calculate concentration, C , of each methyltin chloride in the air volume sampled, V (L):

$$C = \frac{W_f + W_b - B_f - B_b}{V}, \mu\text{g/L or mg/m}^3.$$

EVALUATION OF METHOD:

This method, developed to collect air samples and analyze the methyltin chlorides, was adapted from existing methodology for measuring organotin compounds in air [3,4]. Reference 2 details the validation of this method for sampling and quantifying of trimethyltin chloride, dimethyltin dichloride, and methyltin trichloride in air. The validated method was needed to provide air monitoring capabilities during methyltin chloride and stabilizer production. Table 2 lists the results of the validation experiments, which followed the guidelines established by NIOSH [5]. However, fewer replicates and concentration levels were used than recommended. This method met the NIOSH criteria for accuracy, bias, and sample stability. The recommended sampling conditions are 250 mL/min for 5.5 h maximum for time-weighted average (TWA) sampling and 1000 mL/min for 20 min maximum for short-term exposure limit (STEL) sampling.

REFERENCES:

- [1] Agency for Toxic Substances and Disease Registry (ATSDR) [2005]. Chemical and physical information. In: Toxicological profile for tin and tin compounds. Atlanta, GA: U.S. Department of Health and Human Services, Public Health Service [www.atsdr.cdc.gov/toxprofiles/tp55-c4.pdf].
- [2] Yoder RE [2000]. Validation of a method for the collection and quantification of methyltin chlorides in the air. Philadelphia, PA: Atofina Chemicals. Unpublished.
- [3] NIOSH [1994]. Organotin compounds (as): Method 5504 (supplement issued 3/15/2003). In: Schlecht PC, O'Connor PF, eds. NIOSH manual of analytical methods. 4th ed. Cincinnati, OH: U.S. Department of Health and Human Services, Centers for Disease Control and Prevention, National Institute for Occupational Safety and Health, DHHS (NIOSH) Publication No. 94-113 [www.cdc.gov/niosh/nmam/].
- [4] Shangwei H [1997]. Development of a method for the sampling and analysis of dimethyltin dichloride and trimethyltin chloride. New Orleans, LA: Tulane University, Department of Environmental Sciences, School of Public Health and Tropical Medicine. Unpublished.
- [5] NIOSH [1995]. Guidelines for air sampling and analytical method development and evaluation. By Kennedy ER, Fischbach TJ, Song R, Eller PM, Shulman SA. Cincinnati, OH: U.S. Department of Health and Human Services, Centers for Disease Control and Prevention, National Institute for Occupational Safety and Health, DHHS (NIOSH) Publication No. 95-117 [www.cdc.gov/niosh/docs/95-117/pdfs/95-117.pdf].

METHOD WRITTEN BY:

R.E. Yoder, C. Boraiko, Atofina Chemicals; P.F. O'Connor, NIOSH/DART.

DISCLAIMER: Mention of any company or product does not constitute endorsement by the National Institute for Occupational Safety and Health (NIOSH). In addition, citations to Web sites external to NIOSH do not constitute NIOSH endorsement of the sponsoring organizations or their programs or products. Furthermore, NIOSH is not responsible for the content of these Web sites. All Web addresses referenced in this document were accessible as of the publication date.

Table 1. General information [1]

| Analyte | Formula | MW | CAS No. | RTECS No. | Properties | OSHA PEL* (mg/m ³) | NIOSH REL* (mg/m ³) |
|------------------------|--|--------|-----------|-----------|--|--------------------------------|---------------------------------|
| Methyltin trichloride | CH ₃ Cl ₃ Sn | 240.08 | 993-16-8 | WH8585500 | Colorless crystals; MP 43 °C; BP 171 °C | 0.1 | 0.1 |
| Dimethyltin dichloride | (CH ₃) ₂ Cl ₂ Sn | 219.67 | 753-73-1 | WH7245000 | Colorless crystals; MP 90 °C (107 °C); BP 185 °C to 190 °C | 0.1 | 0.1 |
| Trimethyltin chloride | (CH ₃) ₃ ClSn | 199.26 | 1066-45-1 | WH6850000 | Colorless crystals; MP 37.5 °C; BP 154 °C to 156 °C | 0.1 | 0.1 |

*Measured as the amount of tin for organotin compounds in air.

Table 2. Method evaluation [2]

| Compound | Range Studied (µg tin per sample) | Bias (%) | Precision (\hat{S}_{rt}) (%) | Accuracy (%) |
|------------------------|-----------------------------------|----------|----------------------------------|--------------|
| Trimethyltin chloride | 0.46 to 9.29 | 0.3 | 5.2 | ±11 |
| Dimethyltin dichloride | 0.42 to 9.17 | -2.5 | 5.8 | ±12 |
| Methyltin trichloride | 0.07 to 10.48 | -5.2 | 7.6 | ±16 |

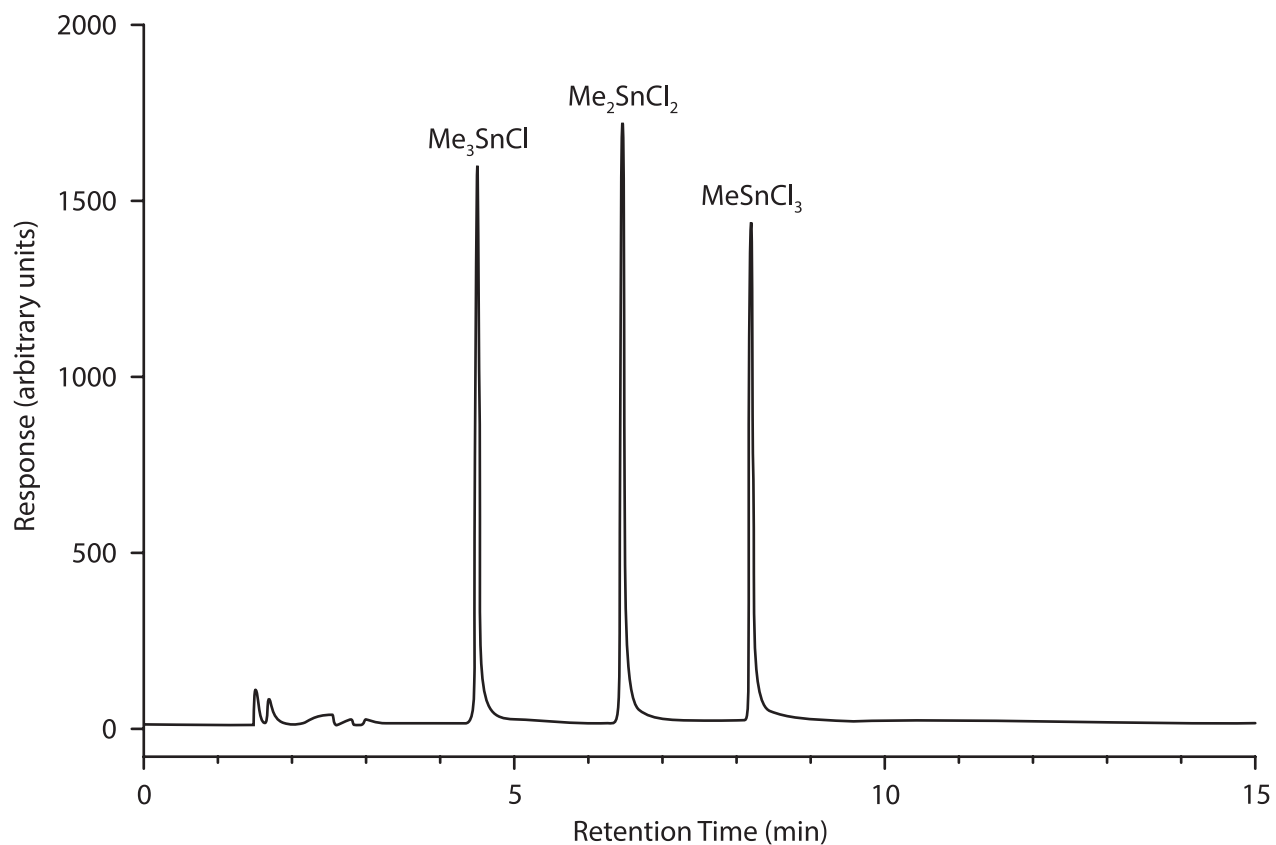

Figure 1. Sample chromatogram.



ORGANOPHOSPHORUS PESTICIDES

5600

Analytes: Table 1 Formula: Table 1 MW: Table 1 CAS: Table 1 RTECS: Table 1

METHOD: 5600, Issue 2

EVALUATION: FULL

Issue 1: 15 August 1993

Issue 2: 2 March 2016

OSHA: Table 2

PROPERTIES: Table 3

NIOSH: Table 2

SYNONYMS: Table 4

| SAMPLING | | MEASUREMENT | |
|--|---|--|--|
| SAMPLER: | FILTER + SOLID SORBENT TUBE (OVS-2 tube: 13-mm quartz filter; XAD-2, 270 mg/140 mg) | TECHNIQUE: | GC, flame photometric detection (FPD) |
| FLOW RATE: | 0.2 to 1 L/min | ANALYTE: | Organophosphorus pesticides, Table 1 |
| VOL-MIN: | 12 L | EXTRACTION: | 2 mL 90% toluene/10% acetone solution |
| -MAX: | 480 L; 60 L (Malathion, Ronnel) | INJECTION VOLUME: | 1 to 2 µL |
| SHIPMENT: | Routine | TEMPERATURE | |
| SAMPLE STABILITY: | at least 10 days @ 25 °C at least 29 days @ 0 °C | -INJECTION: | 240 °C |
| BLANKS: | 2 to 10 field blanks per set | -DETECTOR: | 180 °C to 215 °C (follow manufacturer's recommendations) |
| ACCURACY [9] | | CARRIER GAS: | Helium @ 15 psi (104 kPa) |
| RANGE STUDIED: | Table 5 | COLUMN: | Fused silica capillary column; Table 6 |
| BIAS: | Table 5 | DETECTOR: | FPD (phosphorous mode) |
| OVERALL PRECISION ($\bar{S}_{r,T}$): | Table 5 | CALIBRATION: | Standard solutions of organophosphorus compounds in toluene |
| ACCURACY: | Table 5 | RANGE: | Table 8 |
| | | ESTIMATED LOD: | Table 9 |
| | | PRECISION (\bar{S}_r): | Table 5 |

APPLICABILITY: The working ranges are listed in Table 5. They cover a range of 1/10 to 2 times the OSHA PELs. This method also is applicable to STEL measurements using 12-L samples. This method may be applicable to the determination of other organophosphorous compounds after evaluation for desorption efficiency, sample capacity, sample stability, and precision and accuracy.

INTERFERENCES: Several organophosphates may co-elute with either target analyte or internal standard causing integration errors. These include other pesticides (see Table 7), and the following: tributyl phosphate (a plasticizer), tris-(2-butoxy ethyl) phosphate (a plasticizer used in some rubber stoppers), tricresyl phosphate (a petroleum oil additive, hydraulic fluid, plasticizer, flame-retardant, and solvent), and triphenyl phosphate (plasticizer and flame-retardant in plastics, laquers, and roofing paper).

OTHER METHODS: This method may be used to replace previous organophosphorous pesticide methods. See Table 11 for partial listing. The sampler recommended here is similar in concept to the device of Hill and Arnold [11], but offers greater convenience and lower flow resistance.

REAGENTS:

1. Organophosphorous analytes listed in Table 1; and triphenyl phosphate, analytical standard grade.*
2. Toluene, pesticide analytical grade.*
3. Acetone, ACS reagent grade or better.*
4. Desorbing solution. Add 50 mL acetone to a 500-mL volumetric flask. Dilute to volume with toluene. (Do not keep longer than 30 days at 0-4 °C).
NOTE: For optional internal standard, add 1 mL of a 5 mg/mL solution of triphenyl phosphate in toluene to 500 mL desorbing solution.
5. Organophosphorous stock solutions, 10 mg/mL. Prepare individual standard stock solutions of each pesticide of interest in 90/10 toluene/acetone (v/v). All pesticides in Table 1 were found to be soluble to at least 10 mg/mL.
6. Spiking solutions for calibration (step 9) and media fortification (steps 10, 11)
NOTE: Spiking solutions may contain more than one analyte.
 - a. Spiking solution SS-1: Dilute the volume of stock solution indicated in Table 12 to 10 mL with toluene or 90/10 toluene/acetone (v/v).
NOTE: Spiking solutions may contain more than one analyte.
 - b. Spiking solution SS-0.1: Dilute 1 mL of SS-1 solution with toluene to 10 mL.
7. Purified gases: Helium, Hydrogen, Dry air, Nitrogen, and Oxygen (if required by detector)

*See SPECIAL PRECAUTIONS.

EQUIPMENT:

1. Sampler: resin filled sampling tube; glass tube, 11-mm i.d. x 13-mm o.d. x 50-mm long, with the outlet end drawn to a 6-mm o.d. x 25-mm long tube. The enlarged part of the tube contains a 270-mg front section of 20/60 mesh XAD-2 sorbent held in place by a 9 to 10-mm o.d. quartz fiber filter and polytetrafluoroethylene (PTFE) retaining ring. The front section is separated from the back section of 140 mg XAD-2 sorbent with a short plug of polyurethane foam. The back section is held in place by a long plug of polyurethane foam. The tube is available commercially. See Figure 2.
NOTE: Some commercially available samplers contain glass fiber filters. These are specified in the OSHA methods (see Table 11). These tubes, however, did not perform as well for the more polar analytes (amides, phosphoramides, and sulfoxides; (see Table 10). Low or erratic recoveries for Malathion may be encountered with glass fiber filters.
2. Personal sampling pump, 0.2 to 1 L/min. with flexible connecting tubing, preferably silicon, polyethylene, or PTFE tubing.
3. Vials, 4-mL with PTFE-lined cap; 2-mL GC autosampler vials with PTFE-lined crimp caps.
4. Gas chromatograph, flame photometric detector with 525-nm bandpass filter for phosphorous mode, integrator, and column (Table 6).
5. Syringes, 5-mL and 100-, 50-, and 10-mL for making standard solutions and GC injections.
6. Volumetric flasks, 500-, 10-, and 2-mL.
7. Tweezers.
8. GC vial crimper.
9. Small ultrasonic cleaning bath.

SPECIAL PRECAUTIONS: Organophosphorous compounds are highly toxic. Special care must be taken to avoid inhalation or skin contact through the wearing of gloves and suitable clothing when handling pure material [13,14,15,16,17]. Toluene is flammable and toxic. Acetone is highly flammable. Prepare all samples in a well ventilated hood.

SAMPLING:

1. Calibrate each personal sampling pump with a representative sampler in line.
2. Connect the sampler to personal sampling pump with flexible tubing. The sampler should be placed vertically with the large end down, in the worker's breathing zone in such a manner that it does not impede work performance [12].
3. Sample at an accurately known flowrate between 0.2 and 1 L/min for a total sample size of 12 to 240 L.
4. Cap both ends of the sampler with plastic caps and pack securely for shipment.

SAMPLE PREPARATION:

5. Remove cap from large end and remove PTFE retainer ring; transfer filter and front XAD-2 section to a 4-mL vial. Transfer the short polyurethane foam plug with back-up XAD-2 section to a second 4-mL vial.
6. Add 2-mL of desorbing solvent with internal standard to each vial using a 5-mL syringe or 2-mL pipette. Cap each vial.
7. Allow to stand 30 minutes, immerse vials approximately 1/2 inch in an ultrasonic bath for 30 minutes. Alternatively, place the vials in a shaker or tumbler for 1 hour.
8. Transfer 1 to 1.5 mL from each 4-mL vial to a clean 2-mL GC vial, cap and label.

CALIBRATION AND QUALITY CONTROL:

9. Calibrate daily with at least six working standards covering the analytical range of the method for individual analytes. See Table 12 for recommended preparation of spiking solutions.
 - a. Add known amounts of calibration spiking solution (SS-1 or SS-0.1 according to schedule in Table 12) to desorbing solution in 2-mL volumetric flasks and dilute to the mark.
NOTE: If an internal standard is included in the desorbing solution, then exactly 2 mL of desorbing solution in a volumetric flask must be concentrated slightly under a gentle stream of nitrogen in order to accommodate the specified volume of the spiking solutions. After adding the spiking solutions to the slightly concentrated desorbing solution, dilute to the 2-mL mark with toluene or 90/10 toluene/acetone.
 - b. Include a calibration blank of unspiked desorption solution.
 - c. Analyze together with field samples, field (trip) blanks, and laboratory control samples (step 12 and 13).
 - d. Prepare calibration graph (peak area vs. μg analyte), or if internal standard (IS) is used (peak area of analyte/peak area of IS vs. μg analyte).
10. Prepare Laboratory Control Samples (LCS) with each sample set, in duplicate.
 - a. Remove cap from large end of sampler tube, apply 30 μL of spiking solution SS-1 (refer to Table 13) to face of quartz fiber filter. Cap and allow to stand for a minimum of 1 hour. Preferably, these should be prepared as soon as samples arrive and should be stored with the field samples until analyzed.
 - b. Include an unspiked sampler as a media (method) blank.
 - c. Analyze along with field samples and blanks, and liquid calibration standards (steps 12 through 16).

11. When extending application of this method to other organophosphorous compounds, the following minimal desorption efficiency (DE) test may be performed as follows:
 - a. Determine the NIOSH REL or OSHA PEL, in mg/m³.
 - b. Prepare spiking solution SS-1 (refer to Table 12); or use the following formulae, which are specific for the calculation of the weight of analyte to add to 10 mL 90/10 toluene/acetone).
For REL > 1 mg/m³ (assuming 12-L collection vol.), let W = REL x 4 m³
For REL ≤ 1 mg/m³ (assuming 120-L collection vol.), let W = REL x 40 m³
Where W = weight (mg) of analyte to dissolve into 10 mL of desorbing solvent.
Let [SS-1] = W/10 mL where [SS-1] = concentration of spiking solution SS-1 in mg/mL.
 - c. Prepare spiking solution SS-0.1 by diluting 1 mL of SS-1 to 10 mL in a volumetric flask. Let [SS-0.1] = [SS-1] x 0.1 where [SS-0.1] = concentration of spiking solution SS-0.1.
 - d. Prepare three tubes at each of five levels plus three media blanks. Concentration at each level may be calculated using formulae in last entry of Table 12.
 - i. Remove plastic cap from large end of sampler, apply appropriate volume of spiking solution to face of quartz fiber filter following schedule in Table 13.
 - ii. Cap and allow sampler to stand overnight.
 - e. Prepare tubes for analysis (steps 5 through 8).
 - f. Analyze with liquid standards (steps 12 and 13).
 - g. Prepare a graph of desorption efficiency (DE) vs. µg of analyte.
 - h. Acceptable desorption criteria for 6 replicates is >75% average recovery with a standard deviation of < ±9%.

MEASUREMENT:

12. Set gas chromatograph according to manufacturer's recommendations and to conditions listed in Table 6 and on page 5600-1. Inject sample aliquot manually using solvent flush technique or with autosampler. See Table 7 for retention times of selected analytes.
NOTE: If peak area is greater than the linear range of the working standards, dilute with desorbing solution containing internal standard and reanalyze. Apply the appropriate dilution factor in calculations.
13. Measure peak area of analyte and of internal standard.

CALCULATIONS:

14. Determine the mass in µg (corrected for DE) of respective analyte found in the sample front (W_f) and back (W_b) sorbent sections, and in the media blank front (B_f) and back (B_b) sorbent sections.
NOTE: The filter is combined with front section. If W_b > W_f/10 report breakthrough and possible sample loss.
15. Calculate concentration, C, of analyte in the air volume sampled, V (L):

$$C = \frac{(W_f + W_b - B_f - B_b)}{V}, \frac{mg}{m^3}$$

CONFIRMATION:

16. Whenever an analyte is detected, and its identity is uncertain, confirmation may be achieved by analysis on a second column of different polarity. If primary analysis was performed using a non-polar or weakly polar column (DB-1 or DB-5), confirmation should be accomplished by reanalysis on a polar column (DB-1701 or DB-210). See Table 7 for approximate retention times for each column type. Fewer analytes co-elute on DB-210 than on DB-1701. Relative retention times are more convenient for the identification of unknown analytes. If triphenyl phosphate is not used as the retention time reference compound, then another related compound such as tributyl phosphate, Ronnel, or Parathion may be substituted.

EVALUATION OF METHOD:

This method was evaluated over the ranges specified in Table 5 at 25 °C using 240-L air samples. Sampler tubes were tested at 15% and 80% relative humidity and at 10 °C and 30 °C. In these tests, test atmospheres were not generated; instead, analytes were fortified on the face of the sampler filters. This was followed by pulling conditioned air at 1 L/min for 4 hours. No difference in sampler performance was noted at any of these temperature/humidity combinations. Evaluations of sampler precision and stability were conducted at 30 °C and 15% relative humidity. Overall sampling and measurement precisions, bias, accuracy, and average percent recovery after long-term storage are presented in Table 5. No breakthrough was detected after 12 hours of sampling at 1 L/min with a sampler fortified with the equivalent of 4x the NIOSH REL. Malathion and Ronnel were tested at 1/40 x REL, Sulprofos at 1/20 x REL (See Table 5, note 4). All criteria [9] were met.

REFERENCES:

- [1] NIOSH [1987]. Registry of toxic effects of chemical substances. Sweet DV, ed. Cincinnati, OH: U.S. Department of Health and Human Services, Centers for Disease Control, National Institute for Occupational Safety and Health, DHHS (NIOSH) Publication No. 87-114.
- [2] Budavari, S. ed. [1989]. Merck Index. 11th ed. Rahway, NJ: Merck and Company.
- [3] Sine C, ed. [1991]. Farm chemicals handbook. Willoughby, OH: Meister Publishing Co.
- [4] OSHA [1987]. Methods: PV2015, PV2027, PV2037, PV2045, PV2071, PV2087, PV2099, PV2105, PV2112, and PV2134. In: OSHA Sampling and analytical methods. Salt Lake City, UT: U.S. Department of Labor, Occupational Safety and Health Administration.
- [5] NIOSH [1992]. Recommendations for occupational safety and health. Cincinnati, OH: U.S. Department of Health and Human Services, Centers for Disease Control and Prevention, National Institute for Occupational Safety and Health, DHHS (NIOSH) Publication No. 92-100.
- [6] NIOSH [2016]. NIOSH Pocket guide to chemical hazards. Cincinnati, OH: U.S. Department of Health and Human Services, Centers for Disease Control and Prevention, National Institute for Occupational Safety and Health, DHHS (NIOSH) Publication No. 2010-168c, <http://www.cdc.gov/niosh/npg/>.
- [7] NIOSH [1977]. Methods: P & CAM 158, 295, 336; S208, S209, S210, S280, S285, S295, S296, S299, and S370. In: Taylor DG, ed. NIOSH manual of analytical methods. 2nd ed. Cincinnati, OH: U.S. Department of Health, Education, and Welfare, Center for Disease Control, National Institute for Occupational Safety and Health, DHEW (NIOSH) Publication No. 77-157-C.
- [8] NIOSH [1984]. Methods 2503, 2504, 5012, and 5514. In: Eller PM, Cassinelli ME, eds. NIOSH manual of analytical methods. 3rd ed. U.S. Department of Health and Human Services, Centers for Disease Control, National Institute for Occupational Safety and Health, DHHS (NIOSH) Publication No. 84-100.
- [9] Kennedy ER, Abell MT, Reynolds J, Wickman D [1993]. A sampling and analytical method for the simultaneous determination of multiple organophosphorus pesticides in air. *Am Ind Hyg Assoc J* 55(12):1172-1177.
- [10] J & W Scientific [1991]. J & W Scientific catalog of high resolution chromatography products. Folsom, CA: J & W Scientific.
- [11] Hill RH Jr., Arnold JE [1979]. A personal air sampler for pesticides. *Arch Environ Contam Toxicol* 8:621-628.

- [12] OSHA [1986]. Method 62. In: OSHA Sampling and analytical methods. Salt Lake City, UT: U.S. Department of Labor, Occupational Safety and Health Administration.
- [13] NIOSH [1976]. NIOSH criteria for a recommended standard: occupational exposure to malathion. Cincinnati, OH: U.S. Department of Health, Education, and Welfare, Center for Disease Control, National Institute for Occupational Safety and Health, DHEW (NIOSH) Publication No. 76-205.
- [14] NIOSH [1976]. NIOSH criteria for a recommended standard: occupational exposure to parathion. Cincinnati, OH: U.S. Department of Health, Education, and Welfare, Center for Disease Control, National Institute for Occupational Safety and Health, DHEW (NIOSH) Publication No. 76-190.
- [15] NIOSH [1976]. NIOSH criteria for a recommended standard: occupational exposure to methyl parathion. Cincinnati, OH: U.S. Department of Health, Education, and Welfare, Center for Disease Control, National Institute for Occupational Safety and Health, DHEW (NIOSH) Publication No. 77-106.
- [16] NIOSH [1978]. NIOSH criteria for a recommended standard: occupational exposure during the manufacture and formulation of pesticides. Cincinnati, OH: U.S. Department of Health, Education, and Welfare, Center for Disease Control, National Institute for Occupational Safety and Health, DHEW (NIOSH) Publication No. 78-174.
- [17] Federal Working Group on Pest Management [1974]. Occupational exposure to pesticides: report to the federal working group on pest management from the task group on occupational exposure to pesticides. Washington, D.C.: Federal Working Group on Pest Management. Available as from www.ntis.gov as accession no. PB244259

METHOD WRITTEN BY:

John Reynolds and Donald Wickman, DataChem, Salt Lake City.

Disclaimer: Mention of any company or product does not constitute endorsement by NIOSH. In addition, citations to websites external to NIOSH do not constitute NIOSH endorsement of the sponsoring organizations or their programs or products. Furthermore, NIOSH is not responsible for the content of these websites. All web addresses referenced in this document were accessible as of the publication date.

TABLE 1. Formula and registry numbers

| Compound (alphabetically) | MW ⁽¹⁾ (Daltons) | Empirical Formula | CAS No. ^(2,3,4) | RTECS ⁽²⁾ |
|------------------------------|--------------------------------|---|----------------------------|----------------------|
| Azinphos Methyl | 317.32 | C ₁₀ H ₁₂ N ₃ O ₃ PS ₂ | 86-50-0 | TE1925000 |
| Chlorpyrifos | 350.58 | C ₉ H ₁₁ Cl ₃ NO ₃ PS | 2921-88-2 | TF6300000 |
| Diazinon | 304.34 | C ₁₂ H ₂₁ N ₂ O ₃ PS | 33-41-5 | TF3325000 |
| Dicrotophos | 237.19 | C ₈ H ₁₆ NO ₅ P | 141-66-2 | TC3850000 |
| Disulfoton | 274.39 | C ₈ H ₁₉ O ₂ PS | 298-04-4 | TD9275000 |
| Ethion | 384.46 | C ₉ H ₂₂ O ₄ P ₂ S ₄ | 563-12-2 | TE4550000 |
| Ethoprop | 242.33 | C ₈ H ₁₉ O ₂ PS ₂ | 13194-48-4 | TE4025000 |
| Fenamiphos | 303.36 | C ₁₃ H ₂₂ NO ₃ PS | 22224-92-6 | TB3675000 |
| Fonofos | 246.32 | C ₁₀ H ₁₅ OPS ₂ | 944-22-9 | TA5950000 |
| Malathion | 330.35 | C ₁₀ H ₁₉ O ₆ PS ₂ | 121-75-5 | WM8400000 |
| Methamidophos | 141.12 | C ₂ H ₈ O ₂ PS | 10265-92-6 | TB4970000 |
| Methyl Parathion | 263.20 | C ₈ H ₁₀ NO ₅ PS | 298-00-0 | TG0175000 |
| Mevinphos | 224.15 | C ₇ H ₁₃ O ₆ P | 7786-34-7 | GQ5250000 |
| Monocrotophos | 223.17 | C ₇ H ₁₄ NO ₅ P | 6923-22-4 | TC437500 |
| Parathion | 291.26 | C ₁₀ H ₁₄ NO ₅ PS | 56-38-2 | TF4550000 |
| Phorate | 260.36 | C ₇ H ₁₇ O ₂ PS ₃ | 298-02-2 | TD9450000 |
| Ronnel | 321.54 | C ₈ H ₈ Cl ₃ O ₃ PS | 299-84-3 | TG0525000 |
| Sulprofos | 322.43 | C ₁₂ H ₁₉ O ₂ PS ₃ | 35400-43-2 | TE4165000 |
| Terbufos | 288.42 | C ₉ H ₂₁ O ₂ PS ₃ | 13071-79-9 | TD7740000 |

(1) Molecular weights are calculated from the empirical formula using 1979 IUPAC Atomic Weights of the Elements

(2) RTECS = NIOSH Registry of Toxic Effects of Chemical Substances [1]

(3) Merck Index [2]

(4) Farm Chemicals Handbook [3]

TABLE 2. Toxicity and maximum exposure limits

| Compound (alphabetically) | LD ₅₀ , mg/kg ⁽¹⁾ | OSHA PEL ⁽³⁾ (mg/m ³) | NIOSH REL ⁽⁴⁾ (mg/m ³) | NIOSH REL ⁽⁴⁾ (ppm) |
|------------------------------|---|---|--|-----------------------------------|
| Azinphos Methyl | 11 f | 0.2 | 0.2 | 0.015 |
| Chlorpyrifos | 145 | 0.2 | 0.2 | 0.014 |
| Diazinon | 250 m, 285 f | 0.1 | 0.1 | 0.008 |
| Dicrotophos | 16 f, 21 m | 0.25 | 0.25 | 0.026 |
| Disulfoton | 2.3 f, 6.8 m | 0.1 | 0.1 | 0.009 |
| Ethion | 27 f, 65 m | 0.4 | 0.4 | 0.025 |
| Ethoprop | 61.5 ⁽²⁾ | | | |
| Fenamiphos | 19.4 | 0.1 | 0.1 | 0.008 |
| Fonofos | 3-17 ⁽²⁾ | 0.1 | 0.1 | 0.010 |
| Malathion | 1000 | 15 | 10 | 0.740 |
| Methamidophos | 25 m, 27 f | | | |
| Methyl Parathion | 14 m, 24 f | 0.2 | 0.2 | 0.019 |
| Mevinphos | 3.7 f, 6.1 m | 0.1 skin | 0.1 | 0.01 |
| Monocrotophos | 17 m, 20 f | 0.25 | 0.25 | 0.027 |
| Parathion | 3.6 f, 13m | 0.1 | 0.05 skin | 0.004 |
| Phorate | 1.1 f, 2.3 m | 0.05 | 0.05 skin | 0.005 |
| Ronnel | 1250 m, 2630 f | 15 | 10 | 0.760 |
| Sulprofos | 227 | 1 | 1 | 0.076 |
| Terbufos | 1.6-1.7 m, 1.3-1.57 f | | | |

(1) Rat-oral; from Merck Index, unless otherwise noted, f = female, m = male. [2]

(2) Farm Chemicals Handbook [3]

(3) OSHA Final Rule, 1989 (unenforceable, 1992); only Malathion and Parathion had previous PELs

(4) NIOSH Recommendations for Occupational Safety and Health [5]

TABLE 3. Physical properties ⁽¹⁾

| Compound (Alphabetically) | Liquid Density (g/mL) | mp (°C) | bp (°C @ 1 atm) | Vapor Pressure (Pascal) | Vapor Pressure (mm Hg) | Solubility in Water ^(2,3) , % by weight (g/100mL @ 20 °C) |
|---------------------------|-----------------------|----------------------|---------------------------------|-------------------------|------------------------|--|
| Azinphos Methyl | 1.44 | 73-74 | decomposes | 0.024 | 8x10 ⁻⁹ | 0.003% |
| Chlorpyrifos | 1.40 | 41-42 | 160 (decomposes) | 0.0027 | 2x10 ⁻⁵ | 0.0002% |
| Diazinon | 1.116-1.118 | liquid | >120 (decomposes) | 0.019 | 1.4x10 ⁻⁴ | 0.004% |
| Dicrotophos | 1.216 | liquid | 400 | 0.013 | 0.0001 | miscible |
| Disulfoton | 1.144 | oil | >180 °C flash pt. | 0.0267 | 0.0002 | 0.003% (22.7 °C) |
| Ethion | 1.220 | -12 to -13 | >150 (decomposes) | 0.0002 | 1.5x10 ⁻⁶ | 0.0001% |
| Ethoprop | 1.094 | oil | 86-91 | 0.047 | 3.5x10 ⁻⁴ | 0.075% |
| Fenaminphos | 1.15 | 49 | decomposes | 0.00012 | 5x10 ⁻⁵ | 0.03% |
| Fonofos | 1.16 | 30 | 130 | 0.03 (25 °C) | - | 0.001% |
| Malathion | 1.23 | 2.9 | 60 (decomposes) ⁽⁴⁾ | 0.005 | 4x10 ⁻⁵ | 0.02% |
| Methamidophos | 1.31 | 44 | - | 0.002 | 3x10 ⁻⁴ | - |
| Methyl Parathion | 1.358 | 37-38 | <120 (decomposes) | 0.0002 | 7.5x10 ⁻⁶ | 0.006% (25 °C) |
| Mevinphos | 1.25 ⁽⁵⁾ | 20.6 ⁽⁵⁾ | 300 ⁽⁵⁾ (decomposes) | 0.4 | 3x10 ⁻³ | miscible |
| Monocrotophos | 1.3 | 53-54 ⁽⁶⁾ | 125 | 0.0003 | 7x10 ⁻⁶ | miscible |
| Parathion | 1.26 | 6 | 375 | 0.005 | 3.78x10 ⁻⁵ | 0.001% |
| Phorate | 1.156 | liquid | 118-120 | 0.11 | 8.4x10 ⁻⁴ | 0.005% |
| Ronnel | 1.49 ⁽⁷⁾ | 41 | decomposes | 0.1 | 8x10 ⁻⁴ | 0.004% (25 °C) |
| Sulprofos | 1.20 | liquid | 210 | <0.0001 | <10 ⁻⁶ | low |
| Terbufos | 1.105 | -29.2 | 88 °C flash pt. | 0.0346 | 2.6x10 ⁻⁴ | 0.0005 |

(1) From Merck Index, unless otherwise noted [2].

(2) Farm Chemicals Handbook [3].

(3) NIOSH Pocket Guide [6].

(4) NIOSH 4th Edition Method 5012 (EPN, Malathion, Parathion) [8].

(5) NIOSH 4th Edition Method 2503 for Mevinphos [8].

(6) 54-55 °C for pure material, 25-30 °C for commercial mixture.

(7) NIOSH 2nd Edition Method for Ronnel, S299 [7]

TABLE 4. Synonyms

| Compound ⁽¹⁾ (alphabetically) | Other name ⁽²⁾ | CAS name ^(3,4) |
|---|-------------------------------------|---|
| Azinphos Methyl | Guthion* | O,O-dimethyl S-[(4-oxo-1,2,3-benzotriazin-3(4H)-yl)methyl] phosphorodithioate |
| Chlorpyrifos | Dursban* | O,O-diethyl 0-(3,5,6-trichloro-2-pyridinyl) ester |
| Diazinon | Spectracide* | O,O-diethyl 0-[6-methyl-2-(1-methylethyl)-4-pyrimidinyl] phosphorodithioate |
| Dicrotophos | Bidrin* | 2-dimethyl-cis-2-dimethylcarbamoyl-1-methylvinyl phosphate |
| Disulfoton | Di-Syston* | O,O-diethyl S-[2-(ethylthio)ethyl] phosphorodithioate |
| Ethion | | S,S'-methylene, O,O,O,'O'-tetraethyl ester, O,O,O'-O'-Tetra ethyl S,S'-methylene di-phosphorodithioate ⁽⁴⁾ |
| Ethoprop | Prophos* | Phosphorodithioic acid, 0-ethyl S,S-dipropyl ester |
| Fenamiphos | Nemacur*,Phenamiphos ⁽¹⁾ | Ethyl-3-methyl-4-(methylthio) phenyl (1-methylethyl) phosphoramidate |
| Fonofos | Dyfonate* | O-ethyl, S phenyl ethyl phosphorodithioate |
| Malathion | Cythion* | S-[1,2 bis(ethoxycarbonyl)ethyl] O,O-dimethyl-phosphorodithioate; Diethyl(dimethoxyphosphinothioylthio) succinate |
| Methamidophos | Monitor* | Phosphoramidothioic acid, O,S-dimethyl ester |
| Methyl Parathion | Parathion Methyl ⁽¹⁾ | Phosphorothioic acid, O,O-dimethyl 0-[4-nitrophenyl] ester |
| Mevinphos | Phosdrin* | Methyl-3(dimethoxyphosphinyloxy)but-2-enoate 2-methoxy carbonyl-1-methylvinyl dimethyl phosphate |
| Monocrotophos | Azodrin* Monocron | Dimethyl [1-methyl-3-(methylamino)-3-oxo-1-propenyl] ester ⁽⁴⁾ |
| Parathion | Ethyl Parathion ⁽¹⁾ | O,O-diethyl 0-(4-nitrophenyl) phosphorodithioate |
| Phorate | Thimet* | Phosphorodithioic acid, O,O-diethyl S-[(ethylthio) methyl] phosphorodithioate |
| Ronnel | Fenchlorphos ⁽¹⁾ | O,O-dimethyl O-(2,4,5-trichlorophenyl) ester |
| Sulprofos | Bolstar* | O-ethyl 0-[4-(methylthio) phenyl] S-propyl phosphorodithioate ⁽⁴⁾ |
| Terbufos | Counter* | O,O-diethyl S-[[[(1,1-dimethylethyl) thio] methyl] ester ⁽⁴⁾ |

(1) Common name as given in Farm Chemicals Handbook [3].

(2) *=Trade name (Trademark or Registered Name) as given in Farm Chemicals Handbook [3].

(3) Source, Merck Index [2].

(4) NIOSH RTECS [1] or alternate CAS name in Merck Index [2].

TABLE 5. Method Evaluation ⁽¹⁾

| Compound (alphabetically) | Range Studied ⁽²⁾ (mg/m ³) | Range Studied ⁽²⁾ (mg/sample) | Accuracy | Bias Average | Overall Precision \hat{S}_{RT} | Measurement Precision \bar{S}_R | % Recovery at 30 days @ 25 °C (0 °C) |
|------------------------------|--|---|----------|--------------|----------------------------------|-----------------------------------|--------------------------------------|
| Azinphos Methyl | 0.02-0.4 | 0.0048-0.096 | ±0.178 | -0.038 | 0.070 | 0.030 | 97 (105) |
| Chlorpyrifos | 0.02-0.4 | 0.0048-0.096 | ±0.163 | -0.027 | 0.068 | 0.018 | 92 (90) |
| Diazinon | 0.01-0.2 | 0.0024-0.048 | ±0.162 | -0.032 | 0.065 | 0.020 | 94 (93) |
| Dicrotophos | 0.025-0.5 | 0.006-0.120 | ±0.169 | -0.037 | 0.66 | 0.025 | 89 (92) |
| Disulfoton | 0.01-0.2 | 0.0024-0.048 | ±0.196 | -0.064 | 0.066 | 0.024 | 87 (89) |
| Ethion | 0.04-0.8 | 0.0096-0.192 | ±0.165 | -0.29 | 0.068 | 0.18 | 96 (95) |
| Ethoprop ⁽³⁾ | 0.01-0.2 | 0.0024-0.048 | ±0.157 | -0.025 | 0.066 | 0.024 | 97 (93) |
| Fenaminphos | 0.01-0.2 | 0.0024-0.048 | ±0.155 | -0.029 | 0.063 | 0.022 | 94 (96) |
| Fonofos | 0.01-0.2 | 0.0024-0.048 | ±0.168 | -0.036 | 0.66 | 0.023 | 95 (92) |
| Malathion ⁽⁴⁾ | 0.025-0.5 | 0.006-0.120 | ±0.172 | -0.038 | 0.067 | 0.019 | 93 (93) |
| Methamidophos ⁽⁵⁾ | 0.02-0.4 | 0.0048-0.096 | ±0.156 | -0.018 | 0.069 | 0.026 | 88 (95) |
| Methyl Parathion | 0.02-0.4 | 0.0048-0.096 | ±0.160 | -0.034 | 0.063 | 0.018 | 95 (95) |
| Mevinphos | 0.01-0.2 | 0.0024-0.048 | ±0.176 | -0.42 | 0.067 | 0.028 | 89 (91) |
| Moncrotophos | 0.025-0.5 | 0.006-0.12 | ±0.185 | -0.043 | 0.071 | 0.026 | 88 (92) |
| Parathion | 0.005-0.1 | 0.0012-0.024 | ±0.163 | -0.012 | 0.071 | 0.019 | 92 (92) |
| Phorate | 0.005-0.1 | 0.0112-0.024 | ±0.202 | -0.070 | 0.066 | 0.025 | 91 (91) |
| Ronnel ⁽⁴⁾ | 0.025-0.5 | 0.006-0.120 | ±0.172 | -0.040 | 0.066 | 0.018 | 95 (94) |
| Sulprofos ⁽⁴⁾ | 0.01-0.2 | 0.0024-0.048 | ±0.181 | -0.047 | 0.067 | 0.017 | 94 (94) |
| Terbufos ⁽³⁾ | 0.01-0.2 | 0.0024-0.048 | ±0.188 | -0.054 | 0.067 | 0.022 | 92 (91) |

(1) Back-up Data Report [9]

(2) The ranges studied were 1/10 to 2x the NIOSH REL (except as noted) using a flowrate of 1 L/min. over 4 hours sampling time.

(3) No NIOSH REL or OSHA PEL available; used 0.1 mg/m³.

(4) Malathion and Ronnel were studied at 1/400 to 1/20 the NIOSH REL, Sulprofos at 1/200 to 1/10 the NIOSH REL.

(5) No NIOSH REL or OSHA PEL available; used 0.2 mg/m³.

(6) Data in parentheses are for % recovery at 30 days at 0 °C

TABLE 6. Recommended gas chromatographic columns and conditions⁽¹⁾

| | DB-1 ⁽²⁾ | DB-5 ⁽²⁾ | DB-1701 ⁽²⁾ | DB-210 ⁽²⁾ |
|---|----------------------------|----------------------------|-------------------------------|------------------------------|
| Stationary Phase ⁽³⁾ Polarity | Non- | Weakly | Moderately | Moderately |
| Length (meters) | 30 | 30 | 30 | 30 |
| I.D. (millimeters) | 0.32 | 0.32 | 0.32 | 0.32 |
| Film thickness (mm) ⁽⁴⁾ | 0.25 | 1.0 | 1.0 | 0.25 |
| Injection volume (μL) ⁽⁵⁾ | 1 | 1 | 1 | 1 |
| Injection mode ⁽⁶⁾ | SPL | DIR | DIR | SPL |
| Initial oven temp (°C) | 100 | 125 | 125 | 100 |
| Final oven temp (°C) ⁽⁶⁾ | 275 | 275 | 275 | 250 |
| Recommended max oven temp (°C) ⁽⁷⁾ | 325 | 325 | 280 | 240/260 |
| Oven temp program (°C/min) | 3.0 | 4.0 | 4.0 | 3.0 |
| He Carrier gas head pressure (psi) | 15 | 15 | 15 | 15 |

(1) Actual conditions may vary depending on column and analytical objectives.

(2) Wide Bore Fused Silica Capillary Column

(3) DB-1, 100% methyl silicone; DB-5, 5% phenyl, methyl silicone; DB-1701, 14% cyanopropylphenyl, methyl silicone; DB-210, 50% trifluoropropyl, methyl silicone. DB-1 is non-polar, DB-5 is weakly polar, and DB-1701 and DB-210 are moderately strong polar phases. Equivalent phases are acceptable. Other phase types may also work well.

(4) Film thickness: Thinner films give faster separations at lower temperatures promoting analyte stability.

(5) Injection (Vol.): Use 2 mm i.d. injection port liners for 0.5 mL injection and 4 mm i.d. injection port liners for 1 to 2 mL injections with 0.32 mm i.d. capillary columns.

(6) Injection (mode): SPL = splitless mode, initial oven temp. 5 to 10 °C less than b.p. of desorption solvent; DIR = direct mode, initial oven temperature > b.p. of desorption solvent; OC = on-column, sample injected within the lumen of the column rather than within the injection port liner. In the splitless and direct injection modes, split-vent off time should be 60 seconds for 1 to 2 μL injections with 4 mm i.d. injection port liners, and 20 to 30 seconds for 0.5 μL injections with 2 mm i.d. injection port liners.

(7) J & W Scientific Catalog of High Resolution Chromatography Products, p. 21. [10]

TABLE 7. Approximate retention times (RT) of selected organophosphorous compounds on capillary columns^(1,2)

| Compound (by RT on DB-1) | DB-1 RT (min) | DB-1 RRT ⁽³⁾ | DB-1 Elution T, °C ⁽⁴⁾ | DB-5 RT (min) | DB-1701 RT (min) | DB-210 RT (min) |
|--------------------------|-------------------|-------------------------|-----------------------------------|----------------------|----------------------|----------------------|
| TEPP | 3.71 | 0.128 | 111 | 5.47 | 7.18 ^(B) | 7.88 |
| Triethylphosphorothioate | 4.37 | 0.107 | 113 | 6.34 | 7.14 ^(B) | 4.93 |
| Methamidophos | 5.12 | 0.125 | 115 | 7.64 | 13.61 | 12.03 |
| Dichlorvos | 5.81 | 0.142 | 117 | 8.24 | 10.67 | 10.54 |
| Mevinphos | 10.45 | 0.256 | 131 | 12.92 | 16.69 | 19.20 |
| Ethoprop | 17.15 | 0.420 | 151 | 19.09 | 21.52 | 20.10 |
| Naled | 17.61 | 0.431 | 153 | (6) | 23.17 ^(C) | 21.46 ^(H) |
| Dicrotophos | 18.00 | 0.440 | 154 | 19.94 | 25.84 ^(E) | 31.43 |
| Monocrotophos | 18.27 | 0.447 | 155 | 20.12 | 28.11 | 31.60 |
| Sulfotepp | 19.06 | 0.466 | 157 | (6) | 23.09 ^(C) | 21.11 |
| Phorate | 19.18 | 0.469 | 158 | 20.94 | 23.10 ^(C) | 18.92 |
| Dimethoate | 19.44 | 0.476 | 158 | 21.84 | (6) | 29.33 ^(I) |
| Demeton-S | 20.15 | 0.493 | 160 | 21.70 | 25.06 ^(D) | 24.97 |
| Dioxathion | 21.30 | 0.521 | 164 | 23.04 | 26.33 ^(F) | 23.46 |
| Fonofos | 22.04 | 0.539 | 166 | 23.57 | 25.87 ^(E) | 22.20 |
| Terbufos | 22.22 | 0.544 | 168 | 23.80 | 25.02 ^(D) | 21.52 ^(H) |
| Disulfoton | 23.09 | 0.565 | 169 | 24.19 | 26.43 ^(F) | 22.78 |
| Diazinon | 23.37 | 0.572 | 170 | 23.75 | 25.00 ^(D) | 20.99 |
| Methyl Parathion | 25.37 | 0.621 | 176 | 26.48 | 31.37 | 33.21 |
| Oxydemeton Methyl | 26 ⁽⁵⁾ | 0.63 ⁽⁵⁾ | 179 | (6) | (6) | (6) |
| Ronnel | 26.86 | 0.657 | 181 | 27.39 | 29.30 | 26.27 |
| Pirimiphos Methyl | 28.13 | 0.688 | 184 | 27.90 | 29.72 | 26.77 |
| Malathion | 28.53 | 0.698 | 186 | 28.33 | 31.78 ^(G) | 33.08 ^(J) |
| Fenthion | 28.74 | 0.703 | 186 | 28.93 | 31.78 ^(G) | 29.35 ^(I) |
| Parathion | 28.98 | 0.709 | 187 | 29.10 ^(A) | 33.28 | 35.60 |
| Chlorpyrifos | 29.11 | 0.712 | 187 | 29.10 ^(A) | 30.79 | 27.72 |
| Crufomate | 29.64 | 0.725 | 189 | 29.54 | 34.00 | 35.34 |
| Isofenphos | 31.91 | 0.780 | 196 | 31.17 | 33.81 | 33.02 ^(J) |
| Tetrachlorvinphos | 33.26 | 0.814 | 200 | 32.60 | 35.96 | 37.01 |
| Fenamiphos | 34.09 | 0.834 | 202 | 33.03 | 37.14 | 38.95 |
| Merphos | 35.19 | 0.861 | 206 | (6) | 30.57 | 23.89 |
| Fensulfothion | 36.61 | 0.896 | 210 | 35.78 | 42.41 | 46.98 |
| Ethion | 37.88 | 0.927 | 214 | 36.30 | 39.30 | 37.96 |
| Sulprofos | 38.49 | 0.942 | 216 | 36.96 | 39.54 | 37.11 |
| Triphenyl Phosphate | 40.88 | 1.000 | 223 | 39.06 | (6) | (6) |
| EPN | 42.64 | 1.043 | 228 | 41.06 | 47.83 | 47.13 |
| Azinphos Methyl | 44.16 | 1.080 | 232 | 43.67 | (7) | 49.24 |
| Leptophos | 45.12 | 1.104 | 235 | 43.91 | 47.38 | 41.68 |
| Azinphos Ethyl | 46.55 | 1.139 | 240 | 46.50 | 47.43 | 50.40 |
| Coumaphos | 49.31 | 1.206 | 248 | 50.10 | 67.86 | 60.88 |

(1) Actual retention times (RT) will vary with individual columns and chromatographic conditions. See Table 10 for chromatographic performance notes. Data from Backup Data Report [9].

(2) Capillary Column conditions given in Table 6. Sets of co-eluting or nearly co-eluting peaks are identified by letters: (A), (B), (C), (D), (E), (F), (G), (H), (I), and (J)

(3) Relative Retention Times, relative to Triphenyl Phosphate.

(4) Elution temperature (°C) for DB-1 column (see Table 6 for column conditions.)

(5) Broad, tailing peak.

(6) No data.

(7) Did not elute.

TABLE 8. Applicable working range

| Compound | Atmospheric working range (mg/m ³) ⁽¹⁾ | Atmospheric working range (ppm) ⁽²⁾ | Sample working range (µg/sample) ⁽³⁾ | Instrument working range (ng on column) ⁽⁴⁾ |
|------------------|---|--|---|--|
| Azinphos Methyl | 0.02-0.6 | 0.0015-0.046 | 2.4 to 72 | 1.2-36 |
| Chlorpyrifos | 0.02-0.6 | 0.0014-0.042 | 2.4 to 72 | 1.2-36 |
| Diazinon | 0.01-0.3 | 0.0008-0.024 | 1.2 to 36 | 0.6-18 |
| Dicrotophos | 0.025-0.75 | 0.0026-0.077 | 3.0 to 90 | 1.5-45 |
| Disulfoton | 0.01-0.3 | 0.0009-0.027 | 1.2 to 36 | 0.6-18 |
| Ethion | 0.04-1.2 | 0.0025-0.076 | 4.8 to 144 | 2.4-72 |
| Ethoprop | 0.01-0.3 | 0.0010-0.030 | 1.2 to 36 | 0.6-18 |
| Fenamiphos | 0.01-0.3 | 0.0008-0.024 | 1.2 to 36 | 0.6-18 |
| Fonofos | 0.01-0.3 | 0.0010-0.030 | 1.2 to 36 | 0.6-18 |
| Malathion | 1.0-30 | 0.074-2.2 | 12. to 360(5) | 6.-180(5) |
| Methamidophos | 0.02-0.6 | 0.0035-0.10 | 2.4 to 72 | 1.2-36 |
| Methyl Parathion | 0.02-0.6 | 0.0019-0.056 | 2.4 to 72 | 1.2-36 |
| Mevinphos | 0.01-0.3 | 0.0011-0.033 | 1.2 to 36 | 0.6-18 |
| Monocrotophos | 0.025-0.75 | 0.0027-0.082 | 3.0 to 90 | 1.5-45 |
| Parathion | 0.005-0.15 | 0.0004-0.013 | 0.6 to 18 | 0.3-9 |
| Phorate | 0.005-0.15 | 0.0005-0.014 | 0.6 to 18 | 0.3-9 |
| Ronnel | 1.0-30 | 0.076-2.3 | 12. to 360(5) | 6.-180(5) |
| Sulprofos | 0.1-3.0 | 0.0076-0.23 | 12. to 360 | 6.-180 |
| Terbufos | 0.01-0.3 | 0.0008-0.026 | 1.2 to 36 | 0.6-18 |

(1) To cover range of 1/10 to 3x NIOSH REL.

(2) Calculated for 25 °C and 760 mm Hg (NTP).

(3) Calculated for a collection volume of 120 L (2 hrs @ 1 L/min., 4 hrs @ 0.5 L/min., or 10 hrs @ 0.2 L/min.).

(4) Desorbing sample in 2.0 mL solvent and injecting 1 µL into gas chromatograph.

(5) Calculated for a collection volume of 12 L (12 min. @ 1 L/min., 24 min. @ 0.5 L/min., or 1 hour @ 0.2 L/min.).

TABLE 9. Limits of detection and margin of sensitivity

| Compound | Instrument Estimated LOD (ng on column) | Sample estimated LOD ($\mu\text{g}/\text{sample}$) ⁽¹⁾ | Atmospheric estimated LOD (mg/m^3) ⁽¹⁾ | Margin of sensitivity (REL/LOD) ⁽²⁾ |
|------------------|---|---|---|--|
| Azinphos Methyl | 0.06 | 0.12 | 0.0012 | 167 |
| Chlorpyrifos | 0.02 | 0.04 | 0.0004 | 500 |
| Diazinon | 0.02 | 0.04 | 0.0004 | 250 |
| Dicrotophos | 0.1 | 0.2 | 0.002 | 125 |
| Disulfoton | 0.02 | 0.04 | 0.0004 | 250 |
| Ethion | 0.02 | 0.04 | 0.0004 | 1000 |
| Ethoprop | 0.02 | 0.04 | 0.0004 | (3) |
| Fenamiphos | 0.07 | 0.14 | 0.0014 | 71 |
| Fonofos | 0.02 | 0.04 | 0.0004 | 250 |
| Malathion | 0.05 | 0.1 | 0.001 | 10000 |
| Methamidophos | 0.3 | 0.6 | 0.005 | (3) |
| Methyl Parathion | 0.02 | 0.04 | 0.0004 | 500 |
| Mevinphos | 0.06 | 0.12 | 0.0012 | 83 |
| Monocrotophos | 0.2 | 0.4 | 0.004 | 63 |
| Parathion | 0.02 | 0.04 | 0.0004 | 125 |
| Phorate | 0.02 | 0.04 | 0.0004 | 125 |
| Ronnel | 0.02 | 0.04 | 0.0004 | 25000 |
| Sulprofos | 0.03 | 0.06 | 0.0005 | 2000 |
| Terbufos | 0.02 | 0.04 | 0.0004 | (3) |

(1) Calculated for a collection volume of 120 L (2 hrs @ 1 L/min., 4 hrs @ 0.5 L/min., or 10 hrs @ 0.2 L/min.).

(2) REL in mg/m^3 (Table 2) \div Atmospheric LOD (Table 9).

(3) No REL

TABLE 10. Notes on analytical characteristics of organophosphorous compounds^(1,2)

| Compound (alphabetically) | A. Chemical and Physical | B. Desorption and Dissolution | C. Gas Chromatography |
|-------------------------------------|---------------------------------|--------------------------------------|------------------------------|
| Azinphos Methyl (Guthion*) | - | - | 3,5,6 |
| Azinphos Ethyl (Guthion Ethyl) | - | - | 5 |
| Chlorpyrifos (Dursban*) | - | - | - |
| Coumaphos (Co-Ral*) | - | - | 5 |
| Crufomate (Ruelene*) | 1 | 1,4 | 1 |
| Demeton (Systox*) | 2,6 | 5 | 3 |
| Diazinon (Spectracide*) | - | - | - |
| Dichlorvos (DDVP, Vapona*) | 7 | - | 4 |
| Dicrotophos (Bidrin*) | - | - | - |
| Dimethoate (Cygon*) | 1 | 1,4 | 1 |
| Dioxathion (Delnav*) | - | - | - |
| Disulfoton (Di-Syston*) | 2 | - | 2 |
| EPN (Santox*) | - | - | 5 |
| Ethion | - | - | - |
| Ethoprop (Prophos*) | - | - | - |
| Fenamiphos (Nemacur*) | 1 | 1,4 | 1 |
| Fensulfothion (Dasanit*) | 3 | 4 | - |
| Fenthion (Baytex*) | - | 5 | - |
| Fonofos (Dyfonate*) | - | - | - |
| Isofenphos (Oftanol*) | 1 | 1 | 1 |
| Leptophos (Phosvel*) | - | 5 | 5 |
| Malathion (Cythion*) | - | 1,3,4 | - |
| Merphos (Folex*) | 4 | - | 2 |
| Methamidophos (Monitor*) | 1 | 1,2,4 | 1,4 |
| Methyl Parathion (Parathion Methyl) | - | 5 | - |
| Mevinphos (Phosdrin*) | 6,7 | 1,5 | 3,4 |
| Monocrotophos (Azodrin*) | 1 | - | 1 |
| Naled (Dibrom*) | 5 | - | 2 |
| Oxydemeton Methyl (Metasystox-R) | 3 | - | 1,2 |
| Parathion (Ethyl Parathion) | - | - | - |
| Phorate (Thimet*) | 2,7 | - | 2 |
| Pirimiphos Methyl (Actellic*) | - | - | 4 |
| Ronnel (Fenchlorphos) | - | - | - |
| Sulfotepp (TEDP) | - | - | - |
| Sulprofos (Bolstar*) | - | - | - |
| TEPP | 7 | 5 | 4 |
| Terbufos (Counter*) | 2 | - | 2 |
| Tetrachlorvinphos (Gardona*) | - | - | - |
| Tributyl Phosphate | - | - | 7 |
| Triphenyl Phosphate | - | - | 7 |

* = Trade name, Registered name, or Trademark (Farm Chemicals Handbook [3]).

- (1) Observations made during selection and validation of selected analytes. [9]
- (2) Refer to notes on the following pages.

Table 10 continued. Notes on Analytical Characteristics**A. Chemical and Physical**

1. Amide or phosphoramidate, slightly acidic, very polar chemically.
 2. Alkyl thio-ether, easily oxidized to sulfone and sulfoxide.
 3. Sulfoxides, easily oxidized to sulfone. Also very polar chemically.
 4. Phosphite, easily air oxidized to phosphate (Merphos to DEF).
 5. Vicinal dibromide, easily debrominated (Naled to Dichlorvos).
 6. Two or more isomers commonly exist (e.g. Demeton-O and Demeton-S; cis- and trans-mevinphos).
 7. Relatively volatile, can be lost if media or vials are left uncapped for even a short period of time.
- General: Organophosphorous compounds are easily destroyed at mildly alkaline conditions (pH \geq 8). Losses can occur for trace levels of compounds on alkaline glass surfaces. Glassware should be neutralized after washing, if alkaline detergent is used.

B. Desorption and Dissolution

1. Solubility of concentrated solutions in toluene enhanced by the addition of 1% Methanol or 10% acetone. Solubility in hexane very unfavorable even for dilute solutions.
 2. Changing from 100% toluene to 90/10 toluene/acetone, desorption from glass fiber filters improved from 62% to 98%, desorption from quartz fiber filters improved from 30% to 101%.
 3. Changing from glass fiber filters to quartz fiber filters, desorption in toluene improved from 16% to 88% and desorption in 90/10 toluene/acetone improved from 70% to 99%.
 4. These compounds are more chemically polar than the other listed organophosphorous compounds; desorption from XAD-2 or from glass or quartz fiber filters in hexane was incomplete or non-existent. Desorption in toluene was adequate except as noted in 2 and 3 above. The use of toluene containing 10% acetone improved recoveries for all analytes to satisfactory levels.
 5. The desorption characteristics of these compounds were not evaluated.
- General:
1. The presence of acidic hydrogen or double bonded oxygen anywhere in the molecular structure greatly decreases solubility in non-polar solvents and increases the difficulty of desorption from polar surfaces and sorbents.
 2. While glass fiber filters and toluene desorbant were adequate for most compounds in preliminary tests, the method was given wider application for the more polar compounds by the use of quartz fiber filters and 90/10 toluene/acetone desorbant.
 3. Greater flame photometric detector response was observed for organophosphorous compounds when injections were made in toluene or 90/10 toluene/acetone. Solvents with lower boiling points (e.g. methylene chloride, chloroform, methyl-t-butyl ether, and ethyl acetate) possessed fair to good desorption power, but rendered less satisfactory gas chromatographic responses for the analytes. This effect may be due to better analyte mass-transfer from the injection port to the capillary column with higher boiling solvents using splitless or direct injection techniques.

C. Gas Chromatography

1. Poor chromatography may be encountered with dirty or undeactivated columns or injection ports. Clean quartz wool plugs stuffed in the injection port liner are better than silanized glass wool at reducing losses within the injection port.
2. Multiple, shifted, irregular, or severely tailing peaks may be observed in the chromatogram if degradation or oxidation of the analytes occur prior to injection, within the injection port, or during chromatographic separation on-column.
3. Multiple peaks may be observed due to presence of isomers.
4. Short elution time, compound may co-elute with solvent if oven temperature is too high.
5. Long elution time, compound may be lost if run time is too short, column or injection port is too cool, or split-vent-valve opens too soon when injected in splitless or direct injection mode.
6. Azinphos Methyl did not elute from DB-1701 even though Azinphos ethyl did elute.
7. Potential internal standards: Triphenyl phosphate is more favorable if multiple analytes are expected because it is less volatile and elutes in an area of the chromatogram having fewer competing analytes.

TABLE 11. Other methods of analysis for organophosphorous compounds in air

| Document | Method Number | Organophosphorous Compound(s) |
|---|--|---|
| AEC&T ⁽¹⁾ | | Chlorpyrifos, Demeton-O, Demeton-S, Diazinon, Dimethoate, Malathion, Paraoxon, and Parathion |
| NMAM, 2 nd ed ⁽²⁾ | v. 1 P&CAM 158 v. 5 P&CAM 295 v. 6 P&CAM 336 v. 3 S 208 v. 3 S 209 v. 3 S 210 v. 6 S 280 v. 3 S 285 v. 3 S 295 v. 6 S 296 v. 6 S 299 v. 3 S 370 | Parathion Dichlorvos (DDVP) TEPP Tributyl phosphate Triorthocresyl phosphate Triphenyl phosphate Demeton EPN Parathion Mevinphos Ronnell Malathion |
| NMAM, 4th ed. ⁽³⁾ | 2503 2504 5012 5514 | Mevinphos TEPP EPN, Malathion, and Parathion Demeton |
| OSHA A.M.M. ⁽⁴⁾ | 62 | Chlorpyrifos, Diazinon, Parathion, DDVP, and Malathion |
| OSHA Partially Validated Methods ⁽⁵⁾ | PV2087 PV2045 PV2134 PV2015 PV2027 PV2071 PV2099 PV2037 PV2105 PV2112 | Azinphos methyl Monocrotophos Coumaphos Crufomate Fonofos Pirimiphos Methyl Dicrotophos Sulprofos Disulfoton Methyl Parathion |

(1) Hill and Arnold in Arch. Environ. Contam. & Toxicol . [11]

(2) NIOSH Manual of Analytical Methods, 2nd ed., Volumes 1-7 [7]

(3) NIOSH Manual of Analytical Methods, 4th ed. [8]

(4) OSHA Analytical Methods Manual [12]

(5) OSHA Partially Validated Methods (refer to by name) [4]

TABLE 12. Spiking concentrations for organophosphorous compounds

| Compound | Total µg spiked ⁽¹⁾ at 1/30 x REL | Total µg spiked ⁽¹⁾ at 1/10 x REL | Total µg spiked ⁽¹⁾ at 1/3 x REL | Total µg spiked ⁽¹⁾ at 1 x REL | Total µg spiked ⁽¹⁾ at 3 x REL | Volume (mL) of 10 mg/mL stock solution needed to prepare 10 mL of SS-1 |
|-------------------------------------|--|--|---|---|---|--|
| Azinphos Methyl | 0.8 | 2.4 | 8 | 24 | 72 | 0.8 |
| Chlorpyrifos | 0.8 | 2.4 | 8 | 24 | 72 | 0.8 |
| Diazinon | 0.4 | 1.2 | 4 | 12 | 36 | 0.4 |
| Dicrotophos | 1.0 | 3 | 10 | 30 | 90 | 1.0 |
| Disulfoton | 0.4 | 1.2 | 4 | 12 | 36 | 0.4 |
| Ethion | 1.6 | 4.8 | 16 | 48 | 144 | 1.6 |
| Ethoprop | 0.4 | 1.2 | 4 | 12 | 36 | 0.4 |
| Fenamiphos | 0.4 | 1.2 | 4 | 12 | 36 | 0.4 |
| Fonofos | 0.4 | 1.2 | 4 | 12 | 36 | 0.4 |
| Malathion ⁽³⁾ | 4 | 12 | 40 | 120 | 360 | 4.0 |
| Methamidophos | 0.8 | 2.4 | 8 | 24 | 72 | 0.8 |
| Methyl Parathion | 0.8 | 2.4 | 8 | 24 | 72 | 0.8 |
| Mevinphos | 0.4 | 1.2 | 4 | 12 | 36 | 0.4 |
| Monocrotophos | 1.0 | 3 | 10 | 30 | 90 | 1.0 |
| Parathion | 0.2 | 0.6 | 2 | 6 | 18 | 0.2 |
| Phorate | 0.2 | 0.6 | 2 | 6 | 18 | 0.2 |
| Ronnel ⁽³⁾ | 4 | 12 | 40 | 120 | 360 | 4.0 |
| Sulprofos | 4 | 12 | 40 | 120 | 360 | 4.0 |
| Terbufos | 0.4 | 1.2 | 4 | 12 | 36 | 0.4 |
| General (for 120L) ^(2,3) | x/30 | x/10 | x/3 | x | 3x | 4y |

(1) Total µg per sample, for spiked media, or per 2 mL desorption solution for liquid calibration standards.

(2) Where x, µg/sample = REL, µg/L x 120 L/sample; and y, mg/mL = REL, mg/m³ x 4 m³/mL.

(3) For all REL > 1 mg/m³, use 1/10 x REL in the calculations (assumes that collection volume in these cases would be 12 L instead of 120 L).

TABLE 13. Spiking of media

| Spiking Levels ⁽¹⁾ (fraction of REL) | Spiking Solution | Preferred Syringe Size | Spiking Volume ⁽²⁾ |
|---|------------------|------------------------|-------------------------------|
| 1/30x REL | SS-0.1 | 50 µL | 10 µL |
| 1/10x REL | SS-0.1 | 50 µL | 30 µL |
| 1/3x REL | SS-1 | 50 µL | 10 µL |
| 1x REL | SS-1 | 50 µL | 30 µL |
| 3x REL | SS-1 | 100 µL | 90 µL |

(1) For a collection volume of 120 L. Range corresponds to values within "Working Range" column, Table 8.

(2) For liquid calibration standard preparations, add specified volume to 2 mL desorption solution in 2-mL volumetric flask. For laboratory control samples spiked at the REL, apply volume specified in "Spiking Volume" column to front section of sampler; do in duplicate. For Desorption Efficiency determination, apply specified volume to front section of sampler; do each of five levels in triplicate.

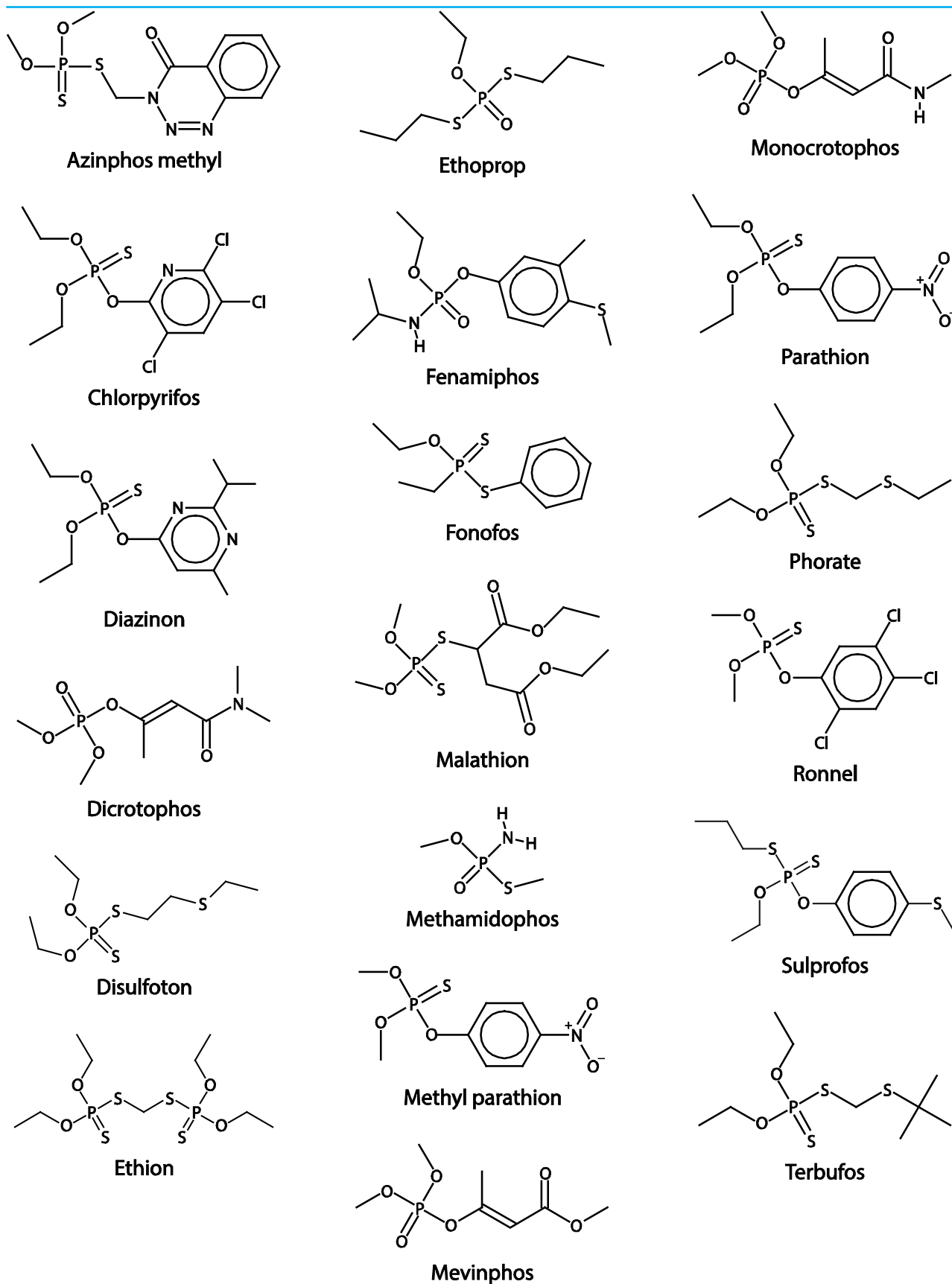

Figure 1. Structures of organophosphorus compounds

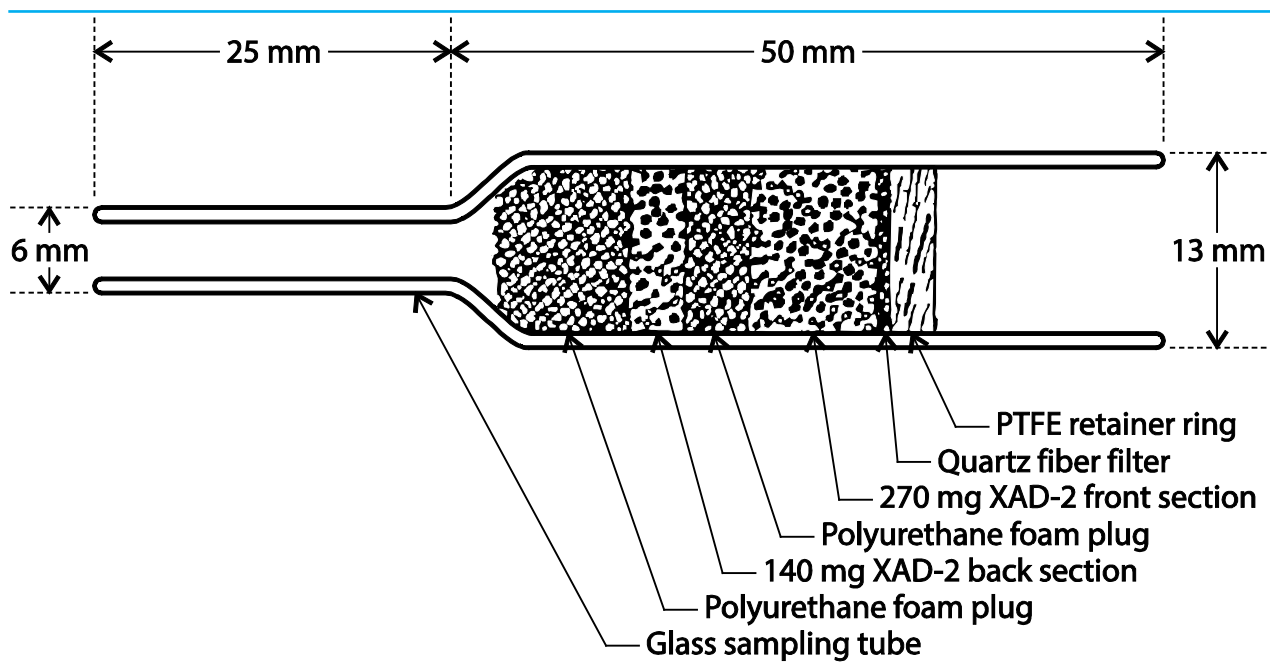

Figure 2. OVS-2 Sampler

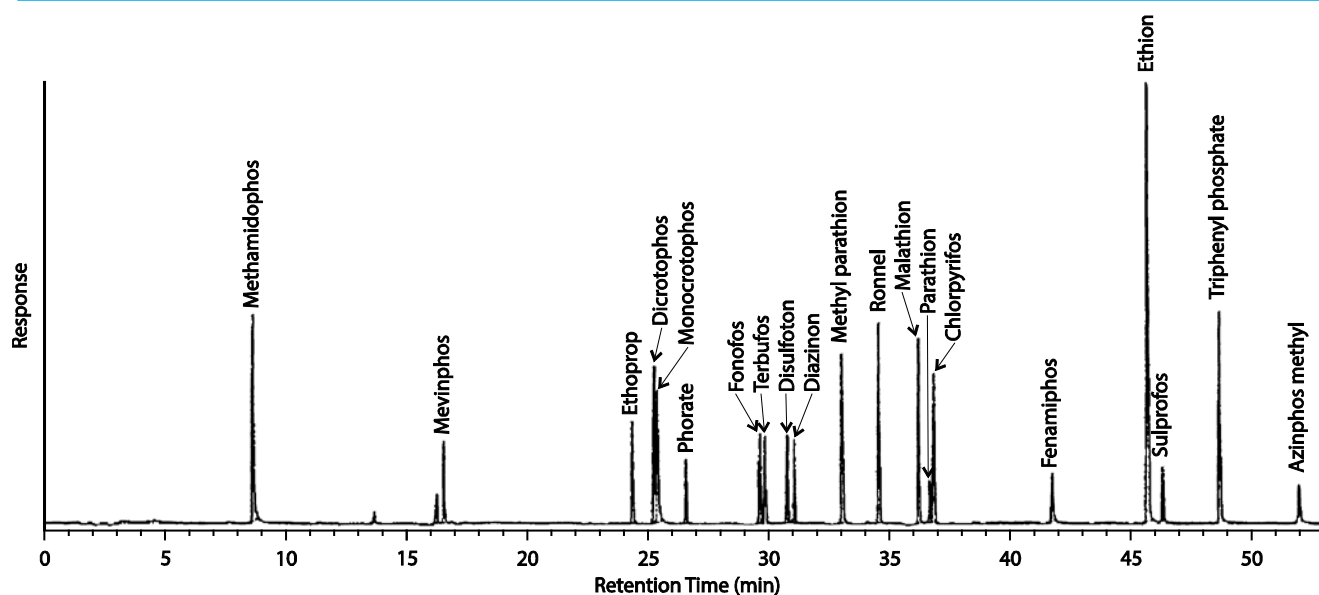

Figure 3. Typical chromatogram of organophosphorus compounds

Column: DB-1 fused silica capillary column, 30 meters x 0.32 mm I.D. x 0.25 μm film thickness

Temperature program: 80 to 275 $^{\circ}\text{C}$ at 3.0 $^{\circ}\text{C}$ per minute.

Concentration of analytes: 0.6 x NIOSH REL, except Sulprofos (0.06x REL), and Malathion and Ronnel (both at 0.006x)

1.8 $\mu\text{g}/\text{mL}$ Parathion and Phorate

3.6 $\mu\text{g}/\text{mL}$ All other compounds

7.2 $\mu\text{g}/\text{mL}$ Azinphos methyl, Chlorpyrifos, Methamidophos, and Methyl parathion

9.0 $\mu\text{g}/\text{mL}$ Dicrotophos and Monocrotophos

14 $\mu\text{g}/\text{mL}$ Triphenyl phosphate

14.4 $\mu\text{g}/\text{mL}$ Ethion



Formula: Figure 1

MW: Table 1

CAS: Table 1

RTECS: Table 1

METHOD: 5601, Issue 2

EVALUATION: FULL

Issue 1: 15 January 1998

Issue 2: 25 February 2016

OSHA: Table 1

PROPERTIES: Table 1

NIOSH: Table 1

SYNONYMS: Aldicarb, Benomyl, Captan, Carbaryl, Carbenazim, Carbofuran, Chlorprophan, Diuron, Formetanate, Methiocarb, Methomyl, Oxamyl, Propham, Propoxur, Thiobencarb (Table 1)

| SAMPLING | | MEASUREMENT | |
|--|---|--|---|
| SAMPLER: | FILTER/SOLID SORBENT TUBE (OVS-2 Tube: 13-mm quartz fiber filter; XAD-2, 270 mg/140 mg) | TECHNIQUE: | HPLC, UV DETECTION |
| FLOW RATE: | 0.1 - 1 L/min [1] | ANALYTE: | organonitrogen pesticides (Table 1) |
| VOL-MIN: | variable (see Table 2) | EXTRACTION: | 2 mL extraction solution (0.2% V/V 0.1 M aqueous triethylamine phosphate buffer in acetonitrile, pH 6.9 to 7.1) |
| -MAX: | 480 L | INJECTION VOLUME: | 5 µL |
| SHIPMENT: | routine | MOBILE PHASE A: | 2% 1-propanol in aqueous 0.02 M triethylamine phosphate (pH 6.9 to 7.1) |
| SAMPLE STABILITY: | at least 30 days @ -12 °C [1] at least 7 days @ 24 °C [1] | MOBILE PHASE B: | 2% 1-propanol in acetonitrile |
| BLANKS: | 2 to 10 field blanks per set | PROGRAM: | mobile phase B, 3 to 95% in 30 min, hold 95% 5 min |
| ACCURACY | | COLUMN: | C18, 30 cm x 3.9-mm ID; ambient temperature (Table 3) |
| RANGE STUDIED: | Table 2 | DETECTOR: | UV absorption at 200 and 225 nm |
| BIAS: | Table 2 | CALIBRATION: | solutions of analytes in extraction fluid |
| OVERALL PRECISION ($\hat{S}_{r,T}$): | Table 2 | RANGE: | Table 2 |
| ACCURACY: | Table 2 | ESTIMATED LOD: | Table 2 |
| | | PRECISION (\hat{S}_r): | Table 2 |

APPLICABILITY: The working ranges (Table 2) for aldicarb, carbofuran, and oxamyl range from 0.5 to 10 times the OSHA PEL. Others cover 0.1 to 2 times the OSHA PELs with appropriate dilutions [1]. This method may be applicable to the determination of other organonitrogen compounds after evaluation, and to a broad range of pesticides having UV chromophores, e.g., acetanilides, acid herbicides, organophosphates, phenols, pyrethroids, sulfonyl ureas, sulfonamides, triazines, and uracil pesticides.

INTERFERENCES: Because of the broad response of the UV detector at shorter wavelengths, there are many potential interferences. Those tested include solvents (chloroform and toluene), antioxidants (BHT), plasticizers (dialkylphthalates), nitrogen compounds (nicotine and caffeine), impurities in HPLC reagents (e.g., in triethylamine), other pesticides (2,4-D, atrazine, parathion, etc.), and pesticide hydrolysis products (1-naphthol). Retention times are given in Table 4. Confirmation techniques are recommended when analyte identity is uncertain.

OTHER METHODS: This method may be used to replace previous related pesticide methods: S273 Carbaryl [2]; 5006 Carbaryl [3]; OSHA 63 Carbaryl and 74 Aldicarb [4]; OSHA Stopgap methods for several pesticides [5]; and EPA TO-10 for Captan, Folpet, and Mexacarbate [6]. The OVS-2 Tube is similar in concept to the device of Hill and Arnold [7], but offers convenience and lower flow resistance.

REAGENTS:

1. Carbamate, urea, and sulfenimide analytes listed in Table 1; internal standards acetanilide and acetophenone, analytical grade.*
2. Acetonitrile, UV grade.*
3. Methanol, HPLC grade.*
4. Deionized water, ASTM Type II.
5. 1-Propanol, UV grade.*
6. n-Butyl isocyanate.*
7. Triethylamine (TEA), HPLC grade.* Keep refrigerated (0 to 4 °C) and store under nitrogen for longer shelf life [1, 8].
8. Ortho-phosphoric acid, >85% by weight, ACS grade or better.*
9. Extraction solution. Prepare separate trimethylamine phosphate (TEA-PO₄) preservative and internal standard solutions.
 - a. TEA-PO₄ preservative, 0.1 M. Dissolve 1.4 mL of TEA in 90 mL of deionized water. Add phosphoric acid to lower pH to 7.0 (± 0.1) as indicated by a calibrated pH meter. Bring volume to 100 mL. Keep tightly capped and refrigerated.
NOTE: Do not use chloroacetic acid as a preservative [9]. Formetanate, at least, is unstable with chloroacetic acid.
 - b. Internal standard stock solution, 5 mg/mL. Add 100 mg of each internal standard of choice for each 20 mL of solution required. Dissolve in acetonitrile. Store capped at -12 ± 1 °C.
 - c. Final extraction solution. Add 1 mL of the TEA-PO₄ solution and 12 mL of the internal standard stock solution to a 500-mL volumetric flask. Dilute to volume with acetonitrile. Concentration of TEA = 0.2 mM, water = 0.2%, and internal standards = 120 µg/mL. Stable up to 30 days at 0 to 4 °C.
10. Individual analyte stock solutions, 5 mg/mL. Add each analyte to acetonitrile in separate volumetric flasks. Use methylene chloride for benomyl and carbendazim. Use 50/50 v/v methanol/acetonitrile or formetanate. Store at -12 ± 1 °C. (Solutions are stable up to 30 days.)

EQUIPMENT

1. Sampler: OSHA Versatile Sampler (OVS-2 tube), resin filled sampling tube; glass tube, 11-mm i.d. x 13-mm o.d. x 50-mm long, with the outlet end drawn to a 6-mm o.d. x 25-mm long tube. The enlarged part of the tube contains a 270-mg front section of 20/60 mesh XAD-2 sorbent held in place by a 9-10-mm o.d. quartz fiber filter and polytetrafluoroethylene (PTFE) retaining ring. The front section is separated from the back section of 140 mg XAD-2 sorbent with a short plug of polyurethane foam. The back section is held in place by a long plug of polyurethane foam. The tube is available commercially. OVS-2 tubes with glass fiber filters have equivalent desorption efficiencies and are commercially available.
2. Personal sampling pump: 0.1 to 1 L/min with flexible and inert connecting tubing.
3. High Performance Liquid Chromatograph capable of mixing two mobile phases in a linear gradient. Must be capable of pumping up to 4000 psi, to accommodate 300 mm long columns.
4. Autosampler, low dead-volume, capable of 5-µL injections. Preservative (TEA-PO₄) in the desorbing solution may be eliminated if a refrigerated autosampler tray is available**
5. Analytical columns.
 - a. Primary column: Base-deactivated octadecylsilyl (C18) column, 3.9-mm ID X 300 mm, 5-µm particle size.
 - b. Secondary column: Cyanopropyl silica column, 4.6 X 250-mm, 5-µm particle size.
6. Guard column, low dead-volume, containing analytical column packing material**
7. Ultraviolet detector, low dead-volume, with 1-cm path length cell capable of monitoring two wavelengths (200- and 225-nm) simultaneously.
8. Vials: 4-mL with PTFE-lined caps; 2-mL HPLC autosampler vials with PTFE- or polyethylene-lined snap caps.
9. Syringes: 0.01-, 0.05-, 0.1-, 1.0- and 2.5-mL; luer lock style, 1- or 2.5-mL for sample filtering.
10. Volumetric flasks: 2-, 5-, 10-, 25-, 50-, 100-, 500-, and 1000-mL.
11. PTFE syringe filter: 0.45-µm.

REAGENTS: (continued)

11. Calibration stock solution. Combine stock solutions of analytes of interest in a volumetric flask to produce the highest concentration standard (suggest 120 to 480 µg/mL).
NOTE: Do not combine benomyl and carbendazim in the same standard solution. [10-12]. See APPENDIX.
12. Quality control spiking solutions: Add analyte stock solutions to acetonitrile at concentrations in the analytical range of the samples. Store in the freezer at -12 ± 1 °C until immediately before spiking.
NOTE: Spiking solutions must not contain internal standard.
13. Mobile phase A. Combine 20 mL of 1-propanol and 2.8 mL of TEA in a 1-L volumetric flask and bring to volume with deionized water. Adjust pH to 7.0 (± 0.1) with phosphoric acid using a pH meter. Final concentrations: 2% 1-Propanol, 0.02 M TEA-PO₄. Degas prior to use.
14. Mobile phase B. Add 20 mL of 1-propanol to acetonitrile in a 1-L volumetric flask and bring to volume. Degas prior to use.

*See SPECIAL PRECAUTIONS.

EQUIPMENT: (continued)

12. Forceps.
13. Small vial/tube tumbler capable of 5 to 10 RPM.
14. pH meter.
15. Graduated cylinders, 10-mL, 25-mL.
16. Pippettes, glass, disposable.

**Low dead volumes will give lower dwell volumes [13, 14] and better resolution [15]

SPECIAL PRECAUTIONS: Pesticides: Avoid inhaling vapors or dust; avoid skin contact. Wear gloves and suitable clothing when handling pure material. Solvents: Avoid skin contact and open flame. Use in a hood. Phosphoric acid: Avoid skin contact. n-Butyl isocyanate may act as a sensitizer. Avoid skin contact.

SAMPLING:

1. Calibrate each personal sampling pump with a representative sampler in line.
2. Connect the sampler to the personal sampling pump with flexible tubing. Place sampler vertically, with the large end down, in the worker's breathing zone.
3. Sample at an accurately known flow rate between 0.1 and 1 L/min for a total sampling volume up to 480 L. Record volume, and document presence of any known or potential interferences.
4. Cap both ends of the sampler with plastic caps and pack securely for shipment.

CALIBRATION AND QUALITY CONTROL

5. Remove cap from large end. Transfer filter, PTFE retainer ring, and front resin section to a 4-mL vial. Transfer the polyurethane foam divider plug along with the back-up resin bed to a second 4-mL vial.
6. Add 2.0 mL of desorbing solvent with internal standards to each vial using a 2.5- or 5-mL syringe or 2-mL pipette; cap each vial.

7. Mix by rotating the vials end-over-end at 5 to 10 RPM for approximately 45 minutes.
8. Filter an aliquot into a 2-mL autosampler vial through a 0.45- μ m PTFE filter.

CALIBRATION AND QUALITY CONTROL

9. Determine retention times for the analytes of interest using the column and chromatographic conditions of choice for the analysis.
10. Calibrate daily with at least six working standards covering the analytical range for individual analytes.
 - a. Prepare working standards by diluting aliquots of the high-level calibration standard with desorbing solution containing internal standard in a volumetric flask. Include an unspiked desorption solution calibration blank.
 - b. Filter aliquots of standards and blanks for analysis (See Step 8).
 - c. Analyze together with samples, blanks, and laboratory control samples (Steps 12 through 14).
 - d. Prepare a calibration graph (ratio of peak area of analyte over peak area of internal standard vs. μ g analyte).

NOTE: Use of an internal standard is recommended [1, 6], but optional if the precision of the injection device and HPLC system are known to be adequate.

11. Prepare desorption efficiency (DE) samples and Laboratory Control Samples (LCS) with each sample set at a rate of 10% of samples.
 - a. Remove cap and the PTFE retainer ring from large end of sampler tube (to prevent wicking behind the ring). Apply known volume of calibration solution to face of quartz fiber filter.

NOTE: Spike no more than 15 to 30 μ L at a time. If more needs to be applied, connect the sampler to a vacuum pump with a flow \leq 1 L/min, then apply spiking solution in 15- to 30- μ L aliquots. Allow several minutes for the solvent to evaporate between each aliquot, to prevent wicking along the sides of the tube into the back-up section (5% or more may deposit on the walls of the tube).
 - b. Cap and allow to stand a minimum of one hour.

NOTE: Prepare LCS when samples arrive and store with field samples until analyzed.
 - c. Include an unspiked sampler as a media (method) blank.
 - d. Analyze with the field samples, blanks, and the liquid standards (Steps 12 through 14).

MEASUREMENT:

12. Set liquid chromatograph according to manufacturer's recommendations and to conditions listed in Table 3. Select two wavelengths for detection with 200 and 225 nm for general-purpose screens. For selected analytes, chose a more specific wavelength UV spectra where available.
13. Inject sample aliquot with autosampler. See Table 4 for approximate retention times of selected analytes.

NOTE: If peak area is greater than the area of the highest standard, dilute with desorbing solution containing internal standards and reanalyze. Apply the appropriate dilution factor in calculations.
14. Measure peak area of analyte(s) and internal standard(s). Divide peak area of analyte by peak area of internal standard on same chromatogram.

CALCULATIONS:

15. Determine the mass, μ g, (corrected for DE) of analyte found in the sample filter and front sorbent section (W_f), back sorbent section (W_b), and the media blank front (B_f) and back (B_b) sorbent sections from a standard curve.

16. Calculate concentration, C (mg/m^3), of each analyte in the air volume sampled, V (L)

$$C = \frac{W_f + W_b - B_f - B_b}{V}, \text{mg}/\text{m}^3$$

NOTE: $\mu\text{g}/\text{mL} \cong \text{mg}/\text{m}^3$

CONFIRMATION:

Retention Times with Alternate Conditions. Whenever the identity of an analyte is uncertain, confirmation may be achieved by analysis on an alternate column. If primary analysis was performed on a base-deactivated octadecylsilyl (C18) column, identity may be confirmed by reanalysis on a cyanopropyl silica column, or by changing to a water/methanol mobile phase (see Table 9 for recommended alternative conditions). See Table 4 for approximate retention times for each column type and condition. Relative retention times (retention indices for a particular set of conditions) are more convenient for the identification of unknown analytes.

UV or Mass Spectra. Confirmation may be achieved through comparison of unknown spectra with reference spectra where available. Relative response ratios will give a moderate level of confirmation. Some analytes (O-aryl carbamates especially) can be confirmed by GC/MS using highly deactivated injection ports and analytical GC columns, or by HPLC/MS.

EVALUATION OF METHOD:

This method was evaluated over the ranges specified in Table 2 at 25 °C with 240-L air samples. Samplers were tested at 15 and 80% relative humidity and 10 and 30 °C. In these experiments, test atmospheres were not generated; instead, analytes were fortified on the face of the sampler filters. The conditioned air was pulled through the samplers at 1 L/min for four hours. No significant difference in sampler performance was noted at any of these temperature/humidity combinations. Evaluation of sampler precision and stability was conducted at ambient conditions of temperature and relative humidity. Overall sampling and measurement precision, bias, accuracy, and average percent recovery after long-term storage are presented in Table 2. No breakthrough was detected with samplers fortified with 480 μg per analyte per tube after sampling eight hours at 1 L/min. For the estimation of LOD/LOQ, a series of media-spiked standards were prepared in triplicate, analyzed, and responses fitted to a quadratic curve. The Limit of Detection (LOD) and Limit of Quantitation (LOQ), given in Table 2, were estimated according to NIOSH SOP 018 [1,17]. Criteria established by NIOSH were met [1].

REFERENCES:

- [1] NIOSH [1995]. Back-up data report: carbamate, urea, and sulfenimide pesticides. Unpublished.
- [2] NIOSH [1977]. Carbaryl: Method S273. In: Taylor DG, ed. NIOSH manual of analytical methods. 2nd ed. (Vol 3) Cincinnati, OH: U.S. Department of Health, Education, and Welfare, Center for Disease Control, National Institute for Occupational Safety and Health, DHEW (NIOSH), Publication No. 77-157-C.
- [3] NIOSH [1994]. Method 5006. In: Eller PM, Cassinelli ME, eds. NIOSH manual of analytical methods. 4th ed. Cincinnati, OH: U.S. Department of Health and Human Services, Centers for Disease Control and Prevention, National Institute for Occupational Safety and Health, DHHS (NIOSH) Publication No. 94-113.
- [4] OSHA [1985]. OSHA Methods 63 and 74. In: OSHA analytical methods manual. Salt Lake City, UT: Carcinogen and Pesticide Branch, OSHA Analytical Laboratory.

-
- [5] OSHA. OSHA Stopgap methods for individual pesticides. Salt Lake City, UT: Carcinogen and Pesticide Branch, OSHA Analytical Laboratory.
- [6] EPA [1986]. EPA compendium of methods for the determination of toxic organic compounds in ambient air. US EPA, Publication No. EPA/600/4-87/006.
- [7] Hill RH Jr., Arnold JE [1979]. A personal air sampler for pesticides. *Arch Environ Contam Toxicol* 8:621-628.
- [8] Dolan JW [1993]. LC troubleshooting. *LC-GC* 11(7):500.
- [9] EPA [1988]. EPA Method 531.1 (Rev. 3.0). In: *Methods for the determination of organic compounds in drinking water*. US EPA. Publication No. EPA 600 4-88 039.
- [10] Chibia, Mikio, Doornbos F [1974]. Instability of benomyl in various conditions. *Bulletin Environ Contam Toxicol* 11(3):273-274.
- [11] Calmon JP, Sayag DR [1976]. Kinetics and mechanism of conversion of methyl 1-(butylcarbamoyl)-2-benzimidazolecarbamate (benomyl) to methyl 2-benzimidazolecarbamate (MBC). *J Agric Food Chem* 24(2):311-314.
- [12] Calmon JP, Sayag DR [1993]. Instability of methyl 1-(butylcarbamoyl)-2-benzimidazolecarbamate (benomyl) in various solvents. *J Agric Food Chem* 24(2):426-428.
- [13] Dolan JW [1993]. LC troubleshooting. *LC-GC* 11(12):858-860.
- [14] Dolan JW [1993]. LC troubleshooting. *LC-GC* 11(6):412-314.
- [15] Dolan JW [1993]. LC troubleshooting. *LC-GC* 12(4):298.
- [16] Gere DR [1993]. Column watch. *LC-GC* 11(10):710-712.
- [17] NIOSH [1995]. Guidelines for air sampling and analytical method development and evaluation. By Kennedy ER, Fischbach TJ, Song R, Eller PM, Schulman SA. Cincinnati, OH: U.S. Department of Health and Human Services, Centers for Disease Control and Prevention, National Institute for Occupational Safety and Health, DHHS (NIOSH) Publication No. 95-117.
- [18] NIOSH [1987]. Registry of toxic effects of chemical substances. U.S. Department of Health and Human Services, Centers for Disease Control, National Institute for Occupational Safety and Health, DHHS (NIOSH) Publication No. 87-114.
- [19] Budavari S, ed. [1989]. *Merck Index*. 11th ed. Rahway, NJ: Merck & Co., Inc.
- [20] Meister [1995]. *Farm Chemicals Handbook*. Willoughby, OH: Meister Publishing Co.
- [21] Wise SA, May WE [1983]. Effect of C18 surface coverage on selectivity in reversed-phase liquid chromatography of polycyclic aromatic hydrocarbons. *Anal Chem* 55(9):1479-1485.
- [22] Cole LA, Dorsey JG [1992]. Temperature dependence of retention in reversed-phase liquid chromatography. 1. Stationary-phase considerations. *Anal Chem* 64(13):1317-1323.
- [23] Wirth MJ [1994]. Column watch. *LC-GC* 12(9):656-664.
- [24] Cole LA, Dorsey JG [1990]. Reduction of reequilibration time following gradient elution reversed-phase liquid chromatography. *Anal Chem* 62(1):16-21.

- [25] Foley JP, May WE [1987]. Optimization of secondary chemical equilibria in liquid chromatography: variables influencing the self-selectivity, retention, and efficiency in acid-base systems. *Anal Chem* 59(1):110-115.
- [26] Dolan JM [1993]. LC troubleshooting. *LC-GC* 11(2):94.
- [27] Roos RW, Lau-Cam CA [1986]. General reversed-phase high-performance liquid chromatographic method for the separation of drugs using triethylamine as a competing base. *J Chrom* 370:403-418.
- [28] Kirkland JJ, Boyes BE, DeStefano JJ [1994]. Changing band spacing in reversed-phase HPLC. *Am Lab Sept*:36-42.
- [29] Seaver, Sadek P, Sadek C [1994]. LC troubleshooting. *LC-GC* 12(10):742-746.
- [30] Zweig, Gunter, Ru-yu G [1983]. Determination of benomyl by reversed-phase liquid chromatography. *Anal Chem* 55(8):1448-1451.
- [31] Dolan, JW [1992]. LC troubleshooting. *LC-GC* 10(10):746.
- [32] Evans CE, Victoria L, McGuffin [1991]. Direct examination of the injection process in liquid chromatographic separations. *Anal Chem* 63(14):1393-1402.
- [33] Steffeck RJ, Woo SL, Weigand RJ, Anderson JM [1995]. A comparison of silica-based C18 and C8 HPLC columns to aid column selection. *LC-GC* 13(9):720-726Body Text.

METHOD REVISED BY:

Jun-Jie Lin, MSPH, and John M. Reynolds, DataChem Laboratories, Salt Lake City, UT.

Disclaimer: Mention of any company or product does not constitute endorsement by NIOSH. In addition, citations to websites external to NIOSH do not constitute NIOSH endorsement of the sponsoring organizations or their programs or products. Furthermore, NIOSH is not responsible for the content of these websites. All web addresses referenced in this document were accessible as of the publication date.

TABLE 1. General Information

| Name/Synonym | Formula | MW | Properties | Solubility in H ₂ O (g/L) | Exposure Limit (mg/m ³) |
|---|---|--------|--|--------------------------------------|-------------------------------------|
| Aldicarb CAS# 116-06-3 RTECS UE2275000 | C ₇ H ₁₄ N ₂ O ₂ S | 190.3 | MP 99-100 °C; vp 3.9 mPa (2.9x10 ⁻⁵ mm Hg) @ 25 °C; LD ₅₀ 1 mg/kg | 6 @ 25 °C | |
| Benomyl CAS# 17804-35-2 RTECS DD6475000 | C ₁₄ H ₁₈ N ₄ O ₃ | 290.36 | MP decomposes; vp <1.3 mPa (<1x10 ⁻⁵ mm Hg) @ 20 °C; LD ₅₀ >9590 mg/kg | 0.002 @ 25 °C | OSHA 5.0 (resp) |
| Captan CAS# 133-06-2 RTECS GW5075000 | C ₉ H ₈ Cl ₃ NO ₂ S | 300.6 | MP 178 °C; vp <1.3 mPa (<1x10 ⁻⁵ mm Hg) @ 20 °C; LD ₅₀ 9000 mg/kg | <0.005 @ ~25 °C | NIOSH 5 |
| Carbaryl CAS# 63-25-2 RTECS FC5950000 | C ₁₂ H ₁₁ NO ₂ | 201.24 | MP 142 °C; vp <5.3 mPa (<4x10 ⁻⁵ mm Hg) @ 25 °C; LD ₅₀ 250 mg/kg | 0.12 @ 30 °C | OSHA 5 NIOSH 5 |
| Carbendazim CAS# 10605-21-7 RTECS DD6500000 | C ₉ H ₉ N ₃ O ₂ | 191.21 | MP 302-307 °C (decomposes); LD ₅₀ 6400 mg/kg | 0.008/pH 7 @ 24 °C | |
| Carbofuran CAS# 1563-66-2 RTECS FB9450000 | C ₁₂ H ₁₅ NO ₃ | 221.28 | MP 150-153 °C; vp 0.031 mPa (2.3x10 ⁻⁷ mm Hg) @ 20 °C; LD ₅₀ 5.3 mg/kg | 0.70 @ 25 °C | NIOSH 0.1 |
| Chlorpropham CAS# 101-21-3 RTECS FD8050000 | C ₁₀ H ₁₂ ClNO ₂ | 213.68 | MP 40.7-41.1 °C; vp 2.7 mPa (2x10 ⁻⁵ mm Hg) @ 33 °C; LD ₅₀ 1200 mg/kg | slightly soluble | |
| Diuron CAS# 330-54-1 RTECS YS8925000 | C ₉ H ₁₀ Cl ₂ N ₂ O | 233.11 | MP 158-159 °C; vp 0.41 mPa (3.1x10 ⁻⁶ mm Hg) @ 50 °C; LD ₅₀ 437 mg/kg | 0.042 @ 25 °C | NIOSH 10 |
| Formetanate.HCl CAS# 23422-53-9 RTECS FC2800000 | C ₁₁ H ₁₆ ClN ₃ O ₂ | 257.75 | MP 200-202 °C (decomposes); LD ₅₀ 20 mg/kg | >50% as hydrochloride | |
| Methiocarb CAS# 2032-65-7 RTECS FC5775000 | C ₁₁ H ₁₅ NO ₂ S | 225.34 | MP 121.5 °C; vp 0.036 mPa (2.7x10 ⁻⁷ mm Hg) @ 25 °C; LD ₅₀ 60 mg/kg | insoluble | |
| Methomyl CAS# 16752-77-5 RTECS AK2975000 | C ₅ H ₁₀ N ₂ O ₂ S | 162.24 | MP 78-79 °C; vp 6.7mPa (5x10 ⁻⁵ mm Hg) @ 25 °C; LD ₅₀ 17 mg/kg | 58 @ 25 °C | NIOSH 2.5 |
| Oxamyl CAS# 23135-22-0 RTECS RP2300000 | C ₇ H ₁₃ N ₃ O ₃ S | 219.3 | MP 100-102 °C; vp 31 mPa (2.4x10 ⁻⁴ mm Hg) @ 20 C; LD ₅₀ 5 mg/kg | 280 @ 25 °C | |
| Propham CAS# 122-42-9 RTECS FD9100000 | C ₁₀ H ₁₃ NO ₂ | 179.24 | MP 90 °C; vp 18 mPa (1.35x10 ⁻⁴ mm Hg); LD ₅₀ 50 mg/kg | 0.25 @ 25 °C | |
| Propoxur CAS# 114-26-1 RTECS FC3150000 | C ₁₁ H ₁₅ NO ₃ | 209.27 | MP 91.5 °C; vp 1.3 mPa (9.75 mm Hg) @ 20 C; LD ₅₀ 83 mg/kg | 2 @ 20 °C | NIOSH 0.5 |
| Thiobencarb CAS# 28249-77-6 RTECS EZ7260000 | C ₁₂ H ₁₆ ClNOS | 257.81 | Not available; LD ₅₀ 1130 mg/kg | ~0.03 @20 °C | |

Abbreviations: MW=molecular weight (Daltons); RTECS=Registry of Toxic Effects of Chemical Substances [18]; LD₅₀=lethal dose 50% [19,20]; mPa=milliPascals

TABLE 2. Method Evaluation

| Compound | Min. Sample Vol (L) | Range Studied (µg/samp) | LOD (µg/ samp) | Mean Bias | Overall Precision (\hat{S}_{rT}) | Accuracy | Storage Stability 31-Day % recovery 24 °C | Storage Stability 31 day % recovery -12 °C |
|--------------|---------------------|-------------------------|----------------|-----------|--------------------------------------|----------|---|--|
| Aldicarb | 240 | 12.0-240 | 1.2 | -0.009 | 0.066 | ± 0.131 | 93.2 | 95.6 |
| Benomyl | 6 | 12.0-120 | 0.6 | A | A | A | A | A |
| Captan | 30 | 48.0-960 | 4.8 | -0.036 | 0.061 | ±0.142 | 98.7 | 102.2 |
| Carbaryl | 6 | 12.0-240 | 0.06 | +0.012 | 0.061 | ±0.123 | 88.2 | 91.8 |
| Carbendazim | 6 | ^B | 0.6 | +0.006 | 0.061 | ±0.121 | 92.1 | 89.3 |
| Carbofuran | 240 | 12.0-240 | 0.6 | -0.020 | 0.060 | ±0.126 | 89.1 | 92.4 |
| Chlorpropham | 6 | 12.0-240 | 0.6 | -0.017 | 0.068 | ±0.140 | 84.3 | 85.9 |
| Diuron | 3 | 12.0-240 | 0.6 | -0.062 | 0.060 | ±0.167 | 86.0 | 87.1 |
| Formetanate. | 60 | 12.0-240 | 0.6 | +0.032 | 0.056 | ±0.129 | 89.8 | 93.0 |
| Methiocarb | 60 | 12.0-240 | 0.6 | +0.009 | 0.061 | ±0.122 | 85.1 | 89.1 |
| Methomyl | 12 | 12.0-120 | 0.6 | -0.002 | 0.063 | ±0.124 | 90.5 | 95.2 |
| Oxamyl | 240 | 12.0-240 | 0.6 | +0.037 | 0.055 | ±0.132 | 94.8 | 95.9 |
| Propham | 3 | 12.0-240 | 0.8 | -0.053 | 0.066 | ±0.168 | 88.5 | 92.5 |
| Propoxur | 60 | 12.0-240 | 0.6 | +0.007 | 0.079 | ±0.156 | 91.4 | 95.4 |
| Thiobencarb | 6 | 12.0-240 | 0.6 | -0.068 | 0.073 | ±0.197 | 75.0 | 79.8 |

^A Results calculated as carbendazim, the primary breakdown product of benomyl.

^B See range for benomyl, a precursor for carbendazim.

TABLE 3. Recommended liquid chromatographic columns and conditions

| | C18 Column | C18 Column | Cyano Column | Cyano Column |
|--|---------------------|-----------------------------------|---------------------|---------------------|
| Solvent | Acetonitrile | Methanol | Acetonitrile | Methanol |
| Application | Primary Analysis | Confirmation | Confirmation | Confirmation |
| Stationary phase | Octadecyl | Octadecyl | Cyanopropyl | Cyanopropyl |
| Length (mm) | 300 | 150 | 250 | 250 |
| ID (mm) | 3.9 | 3.9 | 4.6 | 4.6 |
| Particle size (µm) | 4 | 4 | 5 | 5 |
| Ligand density^A | 2.7 | 2.7 | 5.2 | 5.2 |
| Mobile phase A Solvent | Water | Water | Water | Water |
| Mobile phase A organic modifier^B | 2% 1-propanol | None | None | None |
| Mobile phase A buffer^C | TEA-PO ₄ | None | TEA-PO ₄ | TEA-PO ₄ |
| Mobile phase A concentration (M) | 0.02 M | None | 0.02 M | 0.02 M |
| Mobile phase B solvent^D | Acetonitrile | Methanol | Acetonitrile | Methanol |
| Mobile phase B organic modifier | 2% 1-propanol | None | None | None |
| Initial hold time | 0 | 0 | 0 | 0 |
| Program rate | 3-95% B | 10-80% B | 3-60% B | 3-95% B |
| Program time (min) | 30 | 30 | 30 | 30 |
| Program type | Linear | Linear | Linear | Linear |
| Final hold time (min) | 5 | 5 | 5 | 5 |
| Flow rate (mL/min) | 1.00 | 1.00 | 1.00 | 1.00 |
| Column temperature (°C) | Ambient (~24) | Ambient (~24) | Ambient (~24) | Ambient (~24) |
| Dwell volume (mL) | 0.6-0.8 | 3.5-3.8 | 0.6-0.8 | 0.6-0.8 |
| Injection volume (µL) | 5 | 30 | 5 | 5 |
| Injection solvent | Acetonitrile | 1:3 acetonitrile:H ₂ O | Acetonitrile | Acetonitrile |

^A Ligand density (micromole/m²) is a better description of surface coverage than % carbon loading [22, 23].

^B Choice of alcohol modifier is not critical. Percentages may be varied to adjust retention times and peak shapes for early eluting analytes. Reequilibration time may be shorter with 1-propanol [24-26].

^C Buffer is very essential for basic analytes such as Formentate, Carbendazim, and Benomyl [12,27,28]. Formentate is cationic at about pH 7, and its actual elution time is sensitive to small changes in pH and ionic strength of the buffer in mobile phase A.

^D Acetonitrile is the better choice when monitoring compounds at UV absorptions below 210 nm [20,29].

TABLE 4. Approximate retention times and indices for organonitrogen pesticides and potentially interfering compounds

| Compound ^A (by retention time) | C18 Column Retention index ^B | C18 Column (MeCN solvent) retention time (min) | C18 Column (MeOH solvent) retention time (min) | Cyano Column retention index | Cyano column (MeCN solvent) retention time (min) | Cyano column (MeOH solvent) retention time (min) |
|--|---|--|---|------------------------------------|---|---|
| Solvent void volume | 0.000 | 2.3 | 1.4 | 0.000 | 3.0 | 3.2 |
| Asulam | 0.004 | 2.3 | | | | |
| Imazapyr | 0.372 | 3.2 | | | | |
| Acetaminophen/ <i>IS</i> | 1.000 | 4.7 | | 1.000 | | |
| Oxamyl | 1.269 | 6.1 | 9.9 | 1.865 | 7.0 | 6.4 |
| Caffeine | 1.397 | 6.8 | | | | |
| Methomyl | 1.445 | 7.0 | 10.7 | 1.915 | 7.4 | 6.6 |
| Formetanate | 1.573 | 7.7 | c | 2.574 | 12.8 | 11.3 |
| Sulfometuron methyl | 1.868 | 9.3 | | | | |
| Acetanilide/ <i>IS</i> | 2.000 | 9.9 | | 2.00 | 8.1 | 7.7 |
| Fenuron | 2.053 | 10.2 | | | | |
| 2,4-D acid | 2.064 | 10.2 | | | | |
| Nicotine | 2.179 | 10.8 | | | | |
| Carbendazim | 2.192 | 10.8 | c | 4.274 | 13.6 | 12.9 |
| Chlorimuron ethyl | 2.422 | 11.9 | | | | |
| Aldicarb | 2.755 | 13.5 | 19.9 | 3.00 | 10.5 | 10.1 |
| Tebuthiuron | 2.817 | 13.8 | 23.9 | | | |
| m-Cresol | 2.866 | 14.0 | | | | |
| Bromacil | 2.902 | 14.2 | | | | |
| Hexazinone | 2.921 | 14.3 | | | | |
| Dinoseb | 2.928 | 14.3 | | | | |
| Simazine | 2.938 | 14.3 | | | | |
| Monuron | 2.981 | 14.5 | | | | |
| Acetophenone/ <i>IS</i> | 3.00 | 14.6 | | 3.00 | 10.5 | 9.9 |
| Cyanazine | 3.003 | 14.6 | | | | |
| Metribuzin | 3.115 | 15.0 | | | | |
| Thiodicarb | 3.247 | 15.5 | | | | |
| Aminocarb | 3.301 | 15.7 | | | | |
| Propoxur | 3.317 | 15.8 | 22.9 | 3.675 | 13.1 | 11.9 |
| Bendiocarb | 3.376 | 16.0 | 23.3 | | | |
| Carbofuran | 3.399 | 16.1 | 23.2 | 4.018 | 14.4 | 14.1 |
| Fluometuron | 3.551 | 16.6 | 25.2 | | | |
| Chloroform | 3.601 | 16.8 | | | | |
| Carbaryl | 3.654 | 17.0 | 24.5 | 5.236 | 19.1 | 18.2 |
| Atrazine | 3.668 | 17.1 | | | | |
| Metalaxyl | 3.837 | 17.6 | | | | |
| Diuron | 3.843 | 17.6 | 27.0 | 5.751 | 21.1 | 19.9 |
| DEET | 3.851 | 17.7 | | | | |
| Alpha-Naphthol | 3.893 | 17.8 | | | | |
| Propiophenone/ <i>IS</i> | 4.000 | 18.2 | | 4.00 | 14.4 | |
| Propachlor | 4.241 | 18.8 | | | | |
| Thiophanate | 4.241 | 18.8 | 27.6 | | | |
| Propham | 4.267 | 18.9 | 25.9 | 5.092 | 17.7 | 17.3 |
| Diethyl phthalate | 4.367 | 19.2 | | | | |
| Clomazone | 4.459 | 19.4 | | | | |
| Siduron | 4.615 | 19.9 | | | | |
| Desmedipham | 4.696 | 20.1 | | | | |
| Phenmedipham | 4.700 | 20.1 | >33 | | | |
| Methiocarb | 4.744 | 20.2 | 29.3 | 6.680 | 22.5 | 21.8 |

TABLE 4. Continued

| Compound ^A (by retention time) | C18 Column Retention index ^B | C18 Column (MeCN solvent) retention time (min) | C18 Column (MeOH solvent) retention time (min) | Cyano Column retention index | Cyano column (MeCN solvent) retention time (min) | Cyano column (MeOH solvent) retention time (min) |
|--|---|--|---|------------------------------------|---|---|
| Linuron | 4.848 | 20.5 | 28.9 | | | |
| BDMC/IS | 4.904 | 20.6 | | | | |
| SWEP | 4.919 | 20.7 | | | | |
| Captan | 4.926 | 20.7 | 27.7 | 6.172 | 20.9 | 21.6 |
| Promecarb | 4.981 | 20.8 | 20.4 | | | |
| Butyrophenone/IS | 5.000 | 20.9 | | 5.000 | 17.4 | |
| Mexacarbate | 5.186 | 21.3 | | | | |
| Toluene | 5.269 | 21.5 | | | | |
| Chlorpropham | 5.504 | 22.1 | 30.1 | 6.700 | 23.4 | 23.3 |
| Folpet | 5.537 | 22.2 | >33 | | | |
| Barban | 5.566 | 22.3 | >33 | | | |
| Malathion | 5.731 | 22.7 | | | | |
| Fenitrothion | 5.802 | 22.8 | | | | |
| Benomyl | 5.822 | 22.9 | c | 7.391 | 25.8 | 23.9 |
| Oryzalin | 5.860 | 23.0 | | | | |
| Metolachlor | 5.876 | 23.0 | | | | |
| Alachlor | 5.979 | 23.3 | | | | |
| Acetochlor | 5.983 | 23.3 | | | | |
| Valerophenone/IS | 6.000 | 23.3 | | 6.000 | 20.9 | |
| Captafol | 6.018 | 23.4 | 30.1 | | | |
| Neburon | 6.045 | 23.4 | | | | |
| Parathion | 6.640 | 24.7 | | | | |
| Hexanophenone/IS | 7.000 | 25.5 | | 7.000 | 24.0 | |
| Thiobencarb | 7.148 | 25.8 | 33.4 | 7.916 | 26.2 | 26.8 |
| Heptanophenone/IS | 8.000 | 27.6 | | 8.000 | 26.4 | |
| Di-n-butyl phthalate | 8.016 | 27.6 | | | | |
| Chlorpyrifos | 8.701 | 28.9 | | | | |
| Pendimethalin | 8.724 | 28.9 | | | | |
| 2,4-D butoxyethyl ester | 8.892 | 29.2 | | | | |
| Octanophenone/IS | 9.000 | 29.4 | | 9.000 | 29.0 | |
| BHT | 9.488 | 30.2 | | | | |
| Amitraz | 9.886 | 30.9 | | | | |
| Nonanophenone/IS | 10.000 | 31.1 | | | | |
| 2,4-D ethylhexyl ester | 10.545 | 31.9 | | | | |
| Decanophenone/IS | 11.000 | 32.5 | | | | |

^A Organonitrogen pesticides are in bold letters.

^B Estimated (~) retention times are extrapolated from shorter columns using relative retention times.

^C Without TEA-PO₄ buffer, basic compounds had irregular peak shapes and retention times, or were not detected. Abbreviations: MeCN=acetonitrile; MeOH=methanol; IS=internal standard.

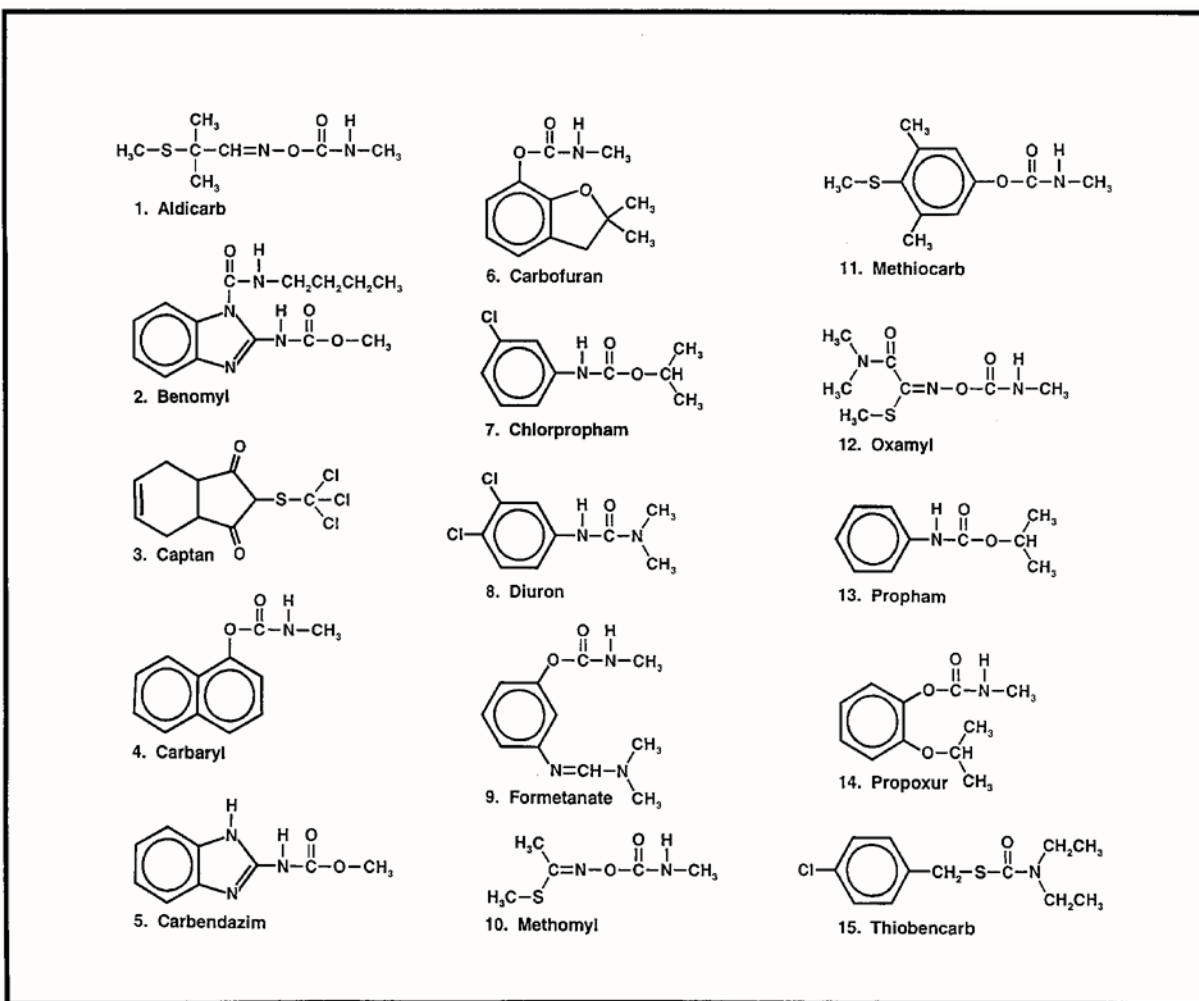

Figure 1. STRUCTURE OF CARBAMATE, UREA, AND SULFENIMIDE PESTICIDES

APPENDIX A. NOTES ON HPLC ANALYSIS OF CARBAMATE, UREA, AND SULFENIMIDE PESTICIDES**A. ANALYTES****1. Aldicarb**

- a. UV response for aldicarb passes through a minimum at approximately 225 nm. If only two wavelength channels are used (225 nm and 200 nm), the response for aldicarb at 200 nm should be monitored. At 205 nm the signal will be smaller, but the signal-to-noise ratio may be better on particular instruments. An alternative but lesser maximum is at approximately 245 to 246 nm. This latter maximum, though small, may have less background noise and interferences from coelutants.
- b. Aldicarb is a highly toxic pesticide. Care should be exercised in handling pure stock material.

2. Benomyl (see also Carbendazim)

- a. Benomyl breaks down rapidly by either hydrolysis in protic solvents (e.g., water or methanol) or solvolysis in nonprotic solvents (e.g., methylene chloride or acetonitrile) to carbendazim. The breakdown of benomyl can be so rapid that no benomyl will be detected at all after approximately 4 to 24 hours at room temperature. The rate of solvolysis is slower in the less polar methylene chloride and very rapid in acetonitrile, even exceeding the rate of hydrolysis [10-12]. Benomyl standards in these nonprotic solvents can be stabilized with the addition of 1% n-butyl isocyanate [30]. The preservative effect is lost as soon as the solution is diluted in solvents that contain or consist of protic solvents, since protic solvents also react with the isocyanates. It is generally unnecessary to add any preservative to the benomyl standard solution (it breaks down anyway). The carbendazim produced can precipitate out, if the solutions are too concentrated. In such an event, the addition of 1% n-butyl isocyanate is essential.
- b. Since benomyl breaks down to carbendazim, do not include both benomyl and carbendazim in the same standard mixture.
- c. When analyzing for benomyl, both benomyl and carbendazim must be determined. The results can be reported as either benomyl or carbendazim by converting the response of one to the equivalent response for the other at any particular wavelength. The relative response of benomyl to carbendazim at 225 nm has been determined to be approximately 1.0738, (adsorption-benomyl/ adsorption-carbendazim). This ratio should be determined for individual instruments with equimolar solutions analyzed separately, and with the benomyl injection solution being preserved with 1% n-butyl isocyanate. To convert carbendazim response to the equivalent benomyl response so that the values can be summed, multiply the carbendazim response by 1.0738 and add this to the benomyl response. Report results as benomyl. Alternately, to report results as carbendazim, divide benomyl response by 1.0738 and then add this to the carbendazim response. Report as total carbendazim.
- d. See notes for carbendazim.

3. Captan

- a. Captan is not stable in methanol or in aqueous mixtures of methanol or acetonitrile at temperatures greater than -12 °C. Therefore, do not dilute desorbing solutions with water or methanol to weaken the injection solvent. Instead, use small injection volumes of acetonitrile solutions.
- b. Use methylene chloride for making stock standard solutions. See Note 16 of this Appendix.
- c. Captan has low absorption at 225 nm (see UV spectrum for captan). If only two wavelength channels are used (225 and 200 nm), the response for captan at 200 nm should be monitored. Although a lesser response may be obtained at approximately 205 or 210 nm, this can be accompanied by a proportionately better signal-to-noise response and may be an optional choice of wavelength if it is compatible with other analytical objectives.

4. Carbaryl (see also Diuron): Carbaryl tends to break down to 1-naphthol. Chloroacetic acid in methanol will inhibit this reaction [9], but this reagent is deleterious to other analytes. Carbaryl is

- stabilized in acetonitrile desorbing solutions containing the TEA- PO₄ preservative for at least 24 hours at room temperature, long enough to permit HPLC analysis. Any 1-naphthol that is detected may represent breakdown of carbaryl prior to desorption or may come from another source. Carbaryl has been stabilized with the TEA-PO₄ buffer/preservative for up to three weeks at room temperature.
5. Carbendazim
 - a. See notes for benomyl.
 - b. Carbendazim can break down to 4-aminobenzimidazole and other compounds. In acetonitrile containing TEA-PO₄ preservative, this breakdown appears to be inhibited for up to 24 hours at room temperature, long enough to permit analysis of desorbates.
 - c. Carbendazim is itself used as a pesticide. There are also other analytes such as thiophanate methyl that can break down to carbendazim. Therefore, any carbendazim should not automatically be assumed to represent benomyl.
 6. Carbofuran
 - a. In most instances carbofuran and bendiocarb coeluted under all conditions tested. Their UV spectra are so nearly alike as to be practically indistinguishable. Any positive identification for carbofuran must be tempered by this knowledge and would require an alternate confirmation such as by mass spectrometry or a knowledge of the history of the sample.
 - b. Propoxur and carbofuran elute very close together. The separation of the two compounds with nearly baseline resolution is a good test of resolving power of the HPLC system for neutral compounds on a C18 HPLC column. If they cannot be resolved, there may be problems with large dead volumes in the system, analytical column quality, or injection quality.
 7. Chlorpropham: No serious problems are expected to be encountered.
 8. Diuron: The breakdown product of carbaryl, 1-naphthol, elutes immediately after diuron under the conditions given. On certain columns, it may coelute with diuron, giving false positive responses. The retention time of 1-naphthol relative to diuron must be determined for any particular column if carbaryl is anticipated to have been present in the sample.
 9. Formetanate
 - a. At analytical concentrations formetanate is not stable either in methanol or in aqueous mixtures of methanol or acetonitrile with or without chloroacetic acid. Therefore, do not dilute desorbing solutions with methanol or water to weaken the injection solvent. Do not use chloroacetic acid as a preservative. Use only small injection volumes of acetonitrile solutions.
 - b. The breakdown of formetanate in analytical solutions is inhibited in acetonitrile containing TEA-PO₄ preservative at room temperature for up to 24 hours, long enough to permit analysis.
 - c. At stock standard concentrations, formetanate dissolves better in 50:50 mixtures of methanol: acetonitrile and is stable if kept in freezer at -12 ± 1 °C.
 - d. Formetanate is basic and possesses a single positive charge in solution at neutral pH (6.9 – 7.1). The use of TEA-PO₄ buffer and/or base-deactivated HPLC columns is essential for the analysis for this compound.
 - e. The exact retention time of formetanate is more affected by exact pH and ionic strength of the buffer (or any other electrolytes) than are the noncharged analytes. Day-to-day inconsistencies in the preparation of mobile phases will cause differences in retention time. If the analyte is eluting too close to methomyl (which just precedes it under the specified conditions), its retention time may be delayed by either raising the pH slightly (by 0.1 to 0.2 units), or by lowering the ionic strength of mobile phase A.
 10. Methiocarb: Methiocarb has the same problems as carbaryl, only to a lesser extent. As methiocarb breaks down, there are several other peaks that arise. These have been shown to be alkylthiophenol and/or oxidation products.
 11. Methomyl: Attention should be placed on the problem of methomyl as it relates to its early elution time. Refer to Notes B1a and B4 of this Appendix.

12. Oxamyl: Attention should be placed on the problem of oxamyl as it relates to its early elution time. Refer to Notes B1a and B4 of this Appendix.
13. Propham: No problems are expected with propham.
14. Propoxur
 - a. With prolonged standing in desorbing solutions at room temperature without preservative, propoxur has been observed to break down to some degree, although much less than carbaryl.
 - b. Propoxur elutes very close to carbofuran. See comments under carbofuran.
15. Thiobencarb: Thiobencarb is relatively nonpolar and has lower (but acceptable) recoveries from the XAD-2 resin than the other analytes.
16. Solvent for Analyte Standard Solutions: Most of the analytes (Table 1) are soluble in acetonitrile at stock standard concentrations. The exceptions are benomyl captan and formetanate. Appropriate solvents are described under headings for these compounds. In each of the solvents mentioned, analytes are stable at -12 ± 1 °C for at least 30 days.
17. Desorption Solvent and Preservative for Analytes: All analytes (except benomyl) were stable in acetonitrile at -12 °C for at least 48 hours. If refrigerated HPLC autosampler trays are available and all desorbing and tumbling operations are carried out in subambient conditions, no preservative should be needed. At room temperature, several analytes (e.g., carbaryl, methiocarb, and oxamyl especially) degraded unpredictably over 24 to 48 hours. The addition of as little as 0.2% v/v of aqueous 0.1 M triethylamine phosphate (TEA-PO₄) buffer, pH 6.9 to 7.1, to the acetonitrile desorption solvent stabilizes all analytes (except benomyl) from hydrolysis or solvolysis for at least 48 hours at room temperature. Methanol, isopropanol, aqueous methanol, and acetonitrile containing any of these alcohols promote degradation of several analytes (especially captan and formetanate) and poor desorption efficiencies. The use of chloroacetic acid, as is required for aqueous samples in EPA Method 531.1 [9], is destructive to at least formetanate. Since the desorption solvent is also the HPLC injection solvent, refer to note on Injection Solvent (B1) for additional comments.

B. HPLC CONDITIONS

1. Injection Solvent
 - a. Normally a solvent producing equal or lower capacity factors than the mobile phase is desirable as an injection solvent in order to produce sharp peaks for early eluting analytes (e.g., oxamyl and methomyl) [31,32]. Since the initial mobile phase mixture of this method is mostly water, the only way to achieve this would be to dilute the samples with water. Water, however, is deleterious to several of the analytes specified in this method (see note A17 above). Therefore, an acceptable alternative is to inject very small volumes, not greater than 5 μ L [31], of the desorption solvent (acetonitrile in this method) on a high-resolution HPLC column. If it is known that only analytes that are stable in aqueous solutions are to be determined (e.g., oxamyl and methomyl, but not formetanate or captan), the desorbates may be diluted with water and larger volumes injected. By diluting with water, sharper peaks may be obtained for early eluting compounds with accelerated elution conditions such as the use of shorter HPLC columns, higher percentages of organic modifier, or higher percentages of mobile phase B in the initial conditions.
 - b. All sample extracts must be filtered through individual 0.45-micron PTFE filters in order to prolong guard column lifetimes and to protect the injection system valving.
 - c. The accidental or intentional inclusion of significant amounts of solvents less polar than acetonitrile in the injection solvent, such as tetrahydrofuran or acetone, may shorten retention times and adversely affect the peak shapes of early elutes (e.g., oxamyl and methomyl) [31].
2. Guard Columns: Guard columns are essential to the long life and reproducibility of results on the main analytical column. There are several on the market. Those giving the lowest possible dead volume preserve good peak shapes and resolution of quality analytical columns and are preferred.

3. Analytical Columns
 - a. General: The main analytical column specified in this method is a C18 reverse-phase column. Other columns known to perform well also may be used, following manufacturer recommendations. There are many good columns available [28, 33].
 - b. Base Deactivation: The basic compounds (benomyl, carbendazim, and formetanate) present special challenges that are easily overcome with highly inert or base-deactivated columns [26]. The addition of TEA-PO₄ buffer to mobile phase A also greatly improves performance for these compounds [16, 26, 27].
 - c. Dimensions: A longer column (300 mm) was used in this method in order to improve resolution for a large number of analytes and interferences, expected and unexpected. Long columns have higher operating pressures; therefore, necessary steps should be taken to provide for them, such as thicker-walled (narrower-bore) transfer lines (if polymer tubing is used, etc.) Shorter columns may work well if a limited number of analytes or interferences are expected. The diameter (3.9-mm) is not necessarily critical and should be governed by user preference and equipment, adjusting flow rates and other parameters as necessary. Diameters from 2.0 to 4.6 mm should be expected to perform similarly, as long as the columns are stable and rugged.
 - d. Packing Density: Packing (or ligand) density is a better parameter than carbon loading for comparing columns [21,22]. A column with a ligand density near that of the one used in this method should be expected to perform similarly.
4. Mobile Phase Composition
 - a. Modifier: Because of the high percentage of water in the initial mobile phase, a condition referred to as hydrophobic collapse of the C18 phase occurs [23,24], which results in poor reequilibration and irreproducible retention times and peak shapes for early eluting analytes such as oxamyl and methomyl. The addition of a constant amount of an alcohol to both mobile phases A and B has been reported and found to improve column performance under these conditions. The method specifies 2% 1-propanol to be added to both mobile phases A and B. A concentration of 1-propanol between 3% and 4% has been reported as optimum [24, 25]; 2% is a compromise made in order to generate retention (capacity) factors for the earliest elutes, oxamyl and methomyl, of greater than 5, as suggested in the literature [26]. Also, 1-propanol has been reported (and found) to reduce the time required for reequilibration at the end of the run [24]. Other alcohols may be used at higher concentrations (except for reducing reequilibration times) [1]. These are isopropanol (at 3% to 5%) and methanol (at 5% to 10%). If early-eluting analytes are to be determined, or if a column is found that gives sufficiently long retention times for the earliest expected elute with an initial mobile phase composition as high as 5% to 10% acetonitrile in water, the alcohol could be eliminated (from both phases). Table 4 would not apply if such changes are made.
 - b. Mobile Phase B: Pure methanol as mobile phase B results in a steep rise in the baseline UV response, making automatic integrations difficult and UV scanning for confirmation spectra nearly impossible. For this reason acetonitrile has been chosen [28, 29]. Methanol is acceptable if these conditions are tolerable and is recommended as an alternate solvent system on a C18 column for confirmation (Section F3); however, precision and LOD values reported in Table 2 would not be applicable.
 - c. Solvent Programming: One of the most serious concerns that may be encountered in trying to make adaptations of this method is an attempt to shorten retention times by using higher concentrations of organic modifier in mobile phase A, higher percentages of mobile phase B in the initial solvent program condition, or faster solvent programming. In any case, these changes will seriously affect the peak shape, sensitivity, and retention time reproducibility of early eluting analytes. There is also a greater possibility of false positives from potential interferences because of poor resolution in the early region of the chromatogram. Retention times for the earliest eluting analyte should be kept at 3 to 6 times the retention time of the

solvent from an unretained analyte, which is equivalent to a capacity factor of 2 to 5 [5]. The retention or capacity factor for any analyte can be calculated as follows:

$$\text{Retention or Capacity factor} = (t_r - t_0)/t_0$$

Where t_r = the retention time of the compound

And t_0 = the retention time of an unretained analyte (the mobile phase holdup time)

The value of keeping analytes from eluting too close to the solvent front cannot be overemphasized.

- d. Buffer: For the compounds evaluated, formetanate, carbendazim, and benomyl required a buffer in order to obtain good peak shapes. Of several pHs tested, pH 6.8 to 7.1 gave the best results. Buffer concentration should be 0.01 to 0.05M. The concentration and pH of the buffer had a great effect on exact retention time of formetanate.
5. Dwell Volumes: Dwell volumes can affect the retention times and peak shapes of analytes. This is internal volume of the system from the point of mixture of the mobile phases A and B to the head of the column. It includes the volume of the transfer lines; any in-line filters (which should be between the pump and the sample injector if at all, and definitely not after the sample injector); the sample injector; the guard column; and the head of the analytical column. This volume can range from approximately 0.6 to 3.8 mL. At a flow rate of 1 mL/minute, each mL dwell volume represents a minute delay between the time that the pump produces a given change in a mixture of solvent and the time when the analytical column experiences that change. In effect, it is equivalent to a solvent program delay [13,14]. For this method, lower dwell volumes and no program delays gave better peak shapes for the early elutes.
6. Dead Volumes: Dead volumes can cause the method to fail seriously. Important areas to look for are larger bore and longer-than-necessary transfer lines between the sample injector and the analytical column [15]. Another area of potential large dead volumes are poorly designed or connected guard columns and sample injectors.
7. UV Wavelength Selection
 - a. The wavelengths specified in this method are a best compromise for all of the analytes listed in Table 1. There are maxima for each of the pesticides that would give greater sensitivity and/or signal-to-noise ratio. If only a selected few of the pesticides in Table 1 are to be determined, other wavelengths may be considered. For example, if only ureas are to be determined, the selection of an absorbance band of 240 to 250 nm would give greater sensitivity for these compounds and less interference from others.
 - b. Spectra are also provided in the Backup Data Report [1] for many analytes and potential interferences. These were obtained under actual operating conditions. Because of unavoidable errors in background subtractions, the profiles of these spectra are subject to errors at the low wavelength ends of the spectra (190 nm to 210 nm). This could be attributed to the absorbance from the alcohol modifier to the mobile phases, which, in spite of efforts to add an equal amount to both phases, produces a slight baseline rise near the end of the chromatograms.
 - c. Many of the O-aryl carbamates and the sulfenimides absorb well only in the low UV range (<215 nm). This is generally an area of great background noise. Many contaminants (plasticizers and solvents) also absorb in this range better than at higher wavelengths. Selecting a longer wavelength that is not at the absorption maximum may give a better signal-to-noise ratio and thus actually increase sensitivity. This should be determined by experimentation for selected analytes.
 - d. Bandwidth: A bandwidth of 15 nm was used for evaluation of this method.
- C. INTERNAL STANDARDS
 1. Calibration Internal Standards: Internal standards are essential for obtaining the precisions listed in Table 2 [1, 16]. Acetanilide was found to be unretained by the media during desorption, and

- therefore, could be added to the extraction fluid. It was also found to be relatively stable and not to interfere with the retention times of other analytes. A second compound, acetophenone, may be added as a back-up internal standard. It is also unretained by all media except XAD-2, on which it has about a 95% recovery. It may be used whenever the acetanilide is interfered with by coeluting analytes or contaminants. It also serves to indicate, by monitoring relative response between the two internal standards, when the first internal standard has a coeluting interference.
2. Alternate Calibration Internal Standards: It may be wise, especially under isocratic conditions, to select other internal standards having capacity factors closer to particular analytes of interest. There is a wide range of alkyl phenones available for late-eluting analytes, and 4-hydroxy-acetanilide (acetaminophen) for earlier eluting analytes. Their retention times are listed in Table 4. Since these longer alkyl chain phenones have increasingly lower recoveries from the XAD-2 resin, they should not be added to the extraction solutions until after the resin is removed.
 3. Retention Index Reference Standards: These are optional standards and are used to establish relative retention times for qualitative purposes. These are highlighted in Table 4 and include a homologous series of alkyl phenones and acetanilides. Establishing retention times between two nearest-eluting reference standards gives a more consistent retention value than retention time alone or relative retention time using a single internal standard alone. This value, the Retention Index, varies according to column and analytical conditions, but should be relatively consistent for any one set of conditions and more reliable as a qualitative tool over a long period of time. This value is calculated as follow:

RI(A) = Retention Index of Analyte "A"

$$\frac{Tr_{(A)} - Tr_{(RS-P)}}{Tr_{(RS-F)} - Tr_{(RS-P)}} + N_{(RS-P)}$$

Where: $Tr_{(A)}$ = retention time of analyte A
 $Tr_{(RS-P)}$ = retention time of preceding reference standard
 $Tr_{(RS-F)}$ = retention time of following reference standard
 $N_{(RS-P)}$ = a number assigned to preceding reference standard, with zero assigned to the first peak in the series.

(Numerical assignments for the acetanilide and phenone series are suggested in Table 4.)

In order to avoid confusion in the chromatograms, the retention index reference standards are analyzed periodically as external standards and not added to the analytical samples themselves. The use of these reference standards is optional but is suggested where application of this method is expected to encounter consistently a broad range of unknown analytes and to augment other confirmatory techniques.

D. INTERFERENCES:

The UV detector responds to many compounds. Retention times of some common potential interferences are provided in Table 4. Interfering compounds that may be encountered are discussed below.

1. DF Impurities in Mobile Phases and Additives: Only HPLC-grade solvents should be used. Triethylamine (TEA) was found to develop unidentified impurities over time which contributed to significant irregularities in the baseline. This degradation was reduced or eliminated by storing the TEA under nitrogen in a small desiccator at 0 to 4 °C [8].
2. Organic Solvents or Fuels
 - a. Chloroform showed a response that nearly coelutes with carbaryl (Table 4). Benomyl and captan, therefore, are made up in methylene chloride, which is more UV transparent than chloroform.
 - b. Toluene (Table 4).

- c. Blends of solvents having ketones, ester, or any of the above compounds, such as lacquer solvents, gasoline, paint stripper, and cleaning solvents, are to be avoided or documented during sample collection and handling.
 3. Industrial Chemicals (Plastic and Rubber Additives)
 - a. Several plasticizers might elute in the window of interest depending upon the selection of column and conditions. These include diethyl and dibutyl phthalates. Dibutyl phthalate is typically found in polyvinyl gloves, flexible tubing, and in coatings on bottles and tool handles. Contact with these materials should be avoided or documented. Other plasticizers, such as dioctyl phthalate and bis-ethylhexyl adipate, have late elution times and will elute after about 30 minutes under the conditions specified. However, if the run times are shortened, these may be carried over on-column to subsequent analyses, causing interferences.
 - b. Common antioxidants such as BHT (2,6-di-tert-butyl-4-methyl phenol) also elute late and may be carried over on-column, creating interferences in subsequent analyses.
 4. Other Pesticides: Spray mixtures very often contain a mixture of pesticides. It is not uncommon to find chlorpyrifos, an organophosphate, or a pyrethroid pesticide in combination with propoxur, for example. Both of these noncarbamate pesticides can be detected under the conditions of the method. The retention time and spectra of chlorpyrifos is included for qualitative purposes. Most pyrethroids elute later than most of the carbamates; if present, they may elute in a subsequent run if run times are too short. It is also not uncommon to mix herbicides of different classes such as diuron with bromacil, atrazine, or 2,4-D. Because of this possibility, retention times and spectra of other common herbicides are also provided in Table 4 for qualitative purposes.
 5. Miscellaneous Chemicals: There are a number of chemicals which elute in the retention time window of interest for carbamates and urea pesticides and may, with particular columns or conditions, interfere with analytes of interest. The presence or the known use of these compounds or their sources should be documented as part of the sample history. Table 4 lists a few of the compounds, which include the following.
 - a. The common insect repellent, DEET (N,N-diethyl-meta-toluamide). Since DEET may be heavily used by outdoor workers, its presence on exposed areas of the skin or clothing may contribute to sampler contamination either through direct contact with the face of the sampler or through collection of vapors if the sampler is in close proximity to areas of application or is exposed to overspray during application from a spray can or bottle.
 - b. Inadvertent collection of tobacco side-stream smoke may introduce potentially interfering compounds, one of which is nicotine.
 - c. Compounds in beverages used during work periods, which include at least caffeine.
- E. SAMPLER
1. The OVS-2 Sampler. The OVS-2 (OSHA Versatile Sampler with XAD-2) combines both filter and XAD-2 sorbent in one unit. The filter is necessary to trap submicron aerosols that would pass through the XAD-2 bed. Substitutions should not be made.
 2. Quartz Fiber and Glass Fiber Filters (GFF). The OVS-2 tubes are available with either glass or quartz fiber filters. OSHA Methods specify GFF. This method specifies a quartz fiber filter. For analytes being desorbed with acetonitrile, no difference in desorption efficiency was observed between glass fiber and quartz fiber filters. Therefore, the tubes may be interchanged for the analytes specified in this method.
 3. Flow Rates. The OVS-2 sampler is designed for a flow rate of 1 L/min. At slower flow rates, 0.1 to 0.2 L/min, there may not be enough capture velocity for aerosols.
 4. Applying Liquid Spikes. The Teflon[®] retainer ring should be removed when spiking the face of the OVS-2 tubes with more than approximately 10 μ L, in order to prevent wicking of the carrier solvent behind the ring and consequent loss of standard. Volumes of spiking fluid greater than 15 to 30 μ L will flood the XAD-2 section and possibly wick into the back-up section. Whenever more than 15 to 30 μ L is to be applied to the tubes, air must be drawn through the tubes at approximately 1

L/min during the spiking procedure and the solvent added in 15- to 30- μ L increments with a few minutes between each addition allowed for drying of the solvent. SD

F. CONFIRMATION

1. By Relative Retention Times (Retention Index). The Retention Index (RI) may vary considerably from column to column and from one set of conditions to another. But it will be reasonably consistent once a set of conditions has been chosen and will be much more reliable for day-to-day comparisons than will absolute retention times. Actual RIs need to be established for each set of conditions. Compounds that are ionic under elution conditions or that interact strongly with polar sites on the column will have the most variable retention times and retention indices.
2. By Second Column. The cyanopropyl stationary phase strongly induces some exchanges in elution orders and alters relative spacings between adjacent analytes in the chromatogram that may be useful in confirmations.
3. By Alternate Solvent. As mentioned earlier (Section B1), methanol as the mobile phase B solvent on a C18 column can be used just as effectively to establish confirmations because methanol interacts differently with the stationary phase than acetonitrile, and so different molecular forces come into play. Significant alterations in retention order are thus obtained; for some analytes this is more dramatic than with a cyanopropyl column.
4. By Ratio of Two UV Absorption Bands. As long as the UV absorption channels are not saturated, there should be a consistent ratio between the background-corrected absorption bands that is characteristic of each analyte and should reflect the ratio of relative heights of the absorption spectra at their respective UV bands in the UV spectra. This ratio is dependent, however, on the bandwidth of the adsorption bands employed, and consistent bandwidths must be used. The consistency of the ratio of absorption across the HPLC peak is also indicative of the purity of the peak. A constantly changing ratio indicates that the peak may have multiple components.
5. By Matching to Reference UV Spectra. Unknown spectra should not be oversaturated in any portion. They need to be background-corrected properly. If the baseline is rising, a background selected from the backside of the peak may induce losses of absorption in the region below 210 nm. Conversely, one selected from in front of the unknown HPLC peak may add to this region of the spectra. It is better to get an averaged background first. Spectra maxima should match within a few nanometers. Relative absorbance at each maxima may vary even after background subtraction, depending upon the concentration of the analytes and the characteristics of different scanning UV detectors.

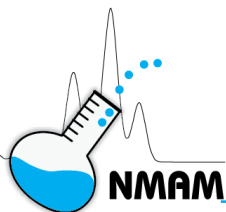

FORMALDEHYDE ON DUST (TEXTILE OR WOOD)

5700

H₂C=O

MW: 30.03

CAS: 50-00-0

RTECS: LP8925000

METHOD: 5700, Issue 2

EVALUATION: FULL

Issue 1: 15 August 1994

Issue 2: 29 February 2016

OSHA: 0.75 ppm; 2 ppm STEL
NIOSH: 0.016 ppm; C 0.1 ppm (15 min); carcinogen

PROPERTIES: gas; BP -19.5 °C; vapor density 1.067 (air = 1);
 explosive range 7 to 73 % in air

SYNONYMS: methanal; formalin (aqueous 30 to 60% w/v formaldehyde); methylene oxide

| SAMPLING | | MEASUREMENT | |
|---|---|--|--|
| SAMPLER: | Institute of Occupational Medicine (IOM) inhalable dust sampler or equivalent containing a 25-mm PVC filter, 5 µm pore size | TECHNIQUE: | HPLC, UV DETECTION |
| FLOW RATE: | 2.0 L/min | ANALYTE: | 2,4-dinitrophenylhydrazone derivative of formaldehyde |
| VOL-MIN: | 240 L @ 0.002 mg/m ³ | EXTRACTION: | 10 mL distilled water @ 37 °C, 4 h; 1 mL to 3 mL 2,4-dinitrophenyl - hydrazine/acetonitrile (1.3 mg/mL DNPH/ACN) |
| -MAX: | 1050 L | INJECTION VOLUME: | 15 µL |
| SHIPMENT: | Place cassette with filter in 30-mL screw-cap low density polyethylene (LDPE) bottle; keep upright. Ship cold. | MOBILE PHASE: | 30% acetonitrile/66% methanol/water (1:1v/v), 1 mL/min |
| SAMPLE STABILITY: | 21 days (matrix dependent) (cold storage advised) | COLUMN: | C18, 5-µm particle size, 10-cm x 8-mm ID (with a C18 guard column) |
| BLANKS: | 2 to 10 field blanks per set | DETECTOR: | UV @ 365 nm |
| ACCURACY | | CALIBRATION: | standard solutions of formaldehyde in 1.3 mg/mL DNPH/ACN |
| RANGE STUDIED: | 0.007 to 0.16 mg/m ³ [1] (1050-L samples) | RANGE: | 0.4 to 4000 µg/sample [1] |
| BIAS: | -4% | ESTIMATED LOD: | 0.8 µg/sample [1] |
| OVERALL PRECISION (\hat{S}_{RT}): | 0.093 [1] | PRECISION (\bar{S}_r): | 0.078 @ 7 to 174 µg per sample [1]. |
| ACCURACY: | ± 22% | | |

APPLICABILITY: The working range is 0.0004 to 3.8 mg/m³ for a 1050-L air sample. This method has been used for the determination of formaldehyde in both textile dusts and wood dusts [1]. Caution should be exercised in the way that data collected with this method are interpreted. These results should be reported separately from vapor-phase formaldehyde exposure data until sufficient data has been collected to allow appropriate epidemiological interpretation of formaldehyde-containing particulate exposures.

INTERFERENCES: None identified

OTHER METHODS: In the absence of phenol or other substances known to interfere with the chromotropic acid analysis of formaldehyde, the analysis procedure described in NIOSH method 3500 [2] can also be used with this extraction technique (See Appendix). The analysis procedure used in this method has also been used for the determination of formaldehyde in automobile exhaust [3]. An alternate analysis [4] may be used in conjunction with this method to determine the amount of "released" formaldehyde from the collected particulate material. NIOSH method 5700 determines both "released" formaldehyde and formaldehyde equivalents (e.g., small oligomeric pieces of formaldehyde-containing resin) present in the hydrolysis solutions. The use of these two analytical approaches may differentiate between the two forms of formaldehyde present in the sample by the difference in results.

REAGENTS:

1. 2,4-dinitrophenylhydrazine (2,4-DNP) (1.3 g) in 1 L acetonitrile; 1.3 mg/mL solution.
2. Formaldehyde stock solution, 1 mg/mL (see Appendix).
3. Methanol, distilled in glass.
4. Acetonitrile, distilled in glass.
5. Water, deionized and distilled.
6. Perchloric acid solution, 1 N. *

*See SPECIAL PRECAUTIONS.

EQUIPMENT:

1. Sampler: 25-mm PVC filter (5.0- μ m pore size) in a 25-mm Institute of Occupational Medicine Inhalable (IOM) dust sampler. The sampler should meet the American Conference of Governmental Industrial Hygienists (ACGIH) definition for collection of the inhalable fraction of particulate mass [5].
2. Personal sampling pump, 2.0 L/min, with flexible polyethylene or polytetrafluoroethylene (PTFE) tubing.
3. Bottles, screw-cap, low-density polyethylene (LDPE), 30-mL.
Note: Do NOT use bottles with 'polycone' liners (source of high formaldehyde blank).
4. Liquid chromatograph with a UV detector, recorder, integrator and column (page 5700-1).
5. Tweezers.
6. Syringes, 10-, 25-, 50-, and 100- μ L.
7. Volumetric flasks, 10-, 100-mL and 1 L.
8. Pipets, 0.1-, 0.5-, 1.0-, and 3-mL glass, delivery, with pipet bulb.
9. Graduated cylinders, glass, 25-mL.
10. Cotton gloves.
11. Equipment for standardizing formaldehyde stock solution, Burets, 50-mL.
12. pH meter.
13. Magnetic stirrer.
14. Beaker, 50-mL.
15. Vials, 5-mL.
16. Filters, 0.45 μ m.
17. Scintillation vials, 20-mL.

SPECIAL PRECAUTIONS: Perchloric acid is a strong oxidizing agent, toxic by ingestion and inhalation and is a strong irritant. Use only in a well-ventilated fume hood. Formaldehyde is a suspect carcinogen [1,6] and should be handled in a hood.

SAMPLING:

1. Calibrate each personal sampling pump with a representative sampler in line.
2. If gravimetric measurements are needed, handle the IOM cassettes only while wearing cotton gloves. Follow NIOSH method 0500 [7] for pre- and post-collection weighing procedure. Place the cassette containing a 25-mm PVC 5- μ m pore filter in the filter holder.
3. Attach outlet of filter holder to the sampling pump.
4. Sample 240 to 1050 L of air at 2.0 L/min flow rate.
5. Transfer cassette from filter holder carefully to a 30-mL LDPE screw-cap bottle while wearing cotton gloves and seal the bottle. Ship in a suitable container in order to prevent damage during transit and keep bottles upright.

6. Collect a bulk sample (ca. 1 g) of the dust/fiber in a glass vial and ship separately.

SAMPLE PREPARATION:

7. If gravimetric weighing is done, post-weigh the entire cassette (see NIOSH method 0500 [7]) then return the cassette to the screw-cap bottle.
8. Transfer 8-mL distilled water to the LDPE screw-cap bottle containing the cassette. Use tweezers (two) to disassemble cassette which is immersed in water, remove all cassette pieces (shake off excess water) leaving the filter and dust in the bottle. Transfer the resulting solution to a 20-mL scintillation vial and rinse the screw-cap bottle with an additional 2 mL of distilled water. Replace the cap on the vial and then place the vial in a 37 °C water bath for four hours. Remove from the bath and allow to cool 1/2 hour. Filter through a 0.45 µm pore size filter into another bottle.

CALIBRATION AND QUALITY CONTROL:

9. Prepare a calibration stock solution by dilution of 1-mL of 1 mg/mL formaldehyde stock solution to 100 mL with distilled water.
10. Pipet aliquots of calibration stock solution (e.g., 40, 200, 750, 2000, 5000, and 10000 µL) into 10-mL volumetric flasks to prepare working standards. Higher level standards, if needed, can be prepared by using different dilutions of the formaldehyde stock solution.
11. Add distilled water to bring the volume of each working standard to 10 mL.
12. Analyze working standards together with samples and blanks (steps 14 through 17).
13. Prepare calibration graph of area vs. amount (µg) of formaldehyde per sample (10-mL total volume).

MEASUREMENT:

14. Transfer a 1-mL aliquot of the solution from step 8 (or step 11) to a 5-mL vial containing 3-mL of an 2,4-dinitrophenylhydrazine/acetonitrile solution (1.3 mg/mL). Add one drop 1 N perchloric acid (to catalyze the reaction to form the corresponding hydrazone), cap the vial and shake it gently for several seconds.
15. Set liquid chromatograph to conditions given on page 5700-1.
16. Inject 15-µL sample aliquot.
17. Measure peak area.

NOTE 1: If peak area is greater than the highest standard, take a smaller aliquot of the remaining unreacted sample solution, dilute to 1 mL with distilled water and analyze (steps 14 through 17) and apply appropriate dilution factor in the calculations.

NOTE 2: For optimum results, all samples containing over 400 µg/mL should be diluted and reanalyzed, since the maximum amount of formaldehyde that can react with 3.9 mg of 2,4-dinitrophenylhydrazine is 590 µg.

CALCULATIONS:

18. Determine mass, µg, of formaldehyde (W) found in the sample and the average media blank (B) from the calibration graph. Use the appropriate aliquot factor (e. g., 1 mL aliquot/original volume from step 14) and the total sample volume (10-mL) unless corrected for in calibration plot (step 13).
NOTE: Include dilution factor for any sample which exceeded the highest calibration standard.
19. Calculate concentration, C, of formaldehyde from dust in the air volume, V (L).

$$C = \frac{W - B}{V}, \text{mg}/\text{m}^3$$

EVALUATION OF METHOD:

This method was evaluated over the range of 7 to 174 $\mu\text{g}/\text{sample}$ at 24 °C and pressure of 761 mm Hg [1] using the chromotropic analysis procedure. Overall measurement precision, \hat{S}_{rT} , was 0.093 including a 5% pump error factor. Similar precision was observed with the 2,4-dinitrophenylhydrazine analysis procedure. Sample stability during storage was evaluated at 7 μg formaldehyde/2 mg of wood dust treated with a urea/formaldehyde resin. Samples showed 101% recovery after 21 days of storage at ambient conditions compared to one-day old samples. However, studies with a different matrix (urea- formaldehyde treated wood fibers) indicated that samples may be unstable when stored at room temperature.

Comparison of results from 2,4-DNP analyses with those from acetylacetone analyses [4] indicated that there was a significant difference between the two methods. The acetylacetone analyses used much milder conditions and appears to be reacting only with released formaldehyde, whereas the 2,4-DNP analysis required the addition of perchloric acid and may be breaking up oligomeric pieces of the partially hydrolyzed resin in the sample. By analyzing samples with the two methods, a further characterization of the sample matrix and potential exposure may be obtained. In matrices where materials that can form complexes with formaldehyde are present, such as sulfites, the acetylacetone analysis may be biased low, since it is unable to break up these complexes [8].

Two comparisons of the IOM samplers with closed-face cassette samplers were conducted in field situations [1]. The IOM samplers, on average, collected more dust/fibers measured gravimetrically than the closed-face cassette samplers in both studies. Formaldehyde levels in the dust/fibers on a $\mu\text{g}/\text{mg}$ basis measured with the extraction procedure used in this method were comparable for both the IOM and closed-face cassette samplers. On the average, the IOM sampler tended to collect more dust than the closed-face cassette sampler.

REFERENCES:

- [1] Kennedy ER, Gagnon YT, Teass AW, Seitz T [1992]. Development and evaluation of a sampling and analytical method for the determination of formaldehyde content of dust. *Appl Occ Environ Hyg* 7(4): 231-240.
- [2] NIOSH [1994]. Formaldehyde: Method 3500. In: Eller PM, Cassinelli ME, eds. NIOSH manual of analytical methods. 4th ed. Cincinnati, OH: U.S. Department of Health and Human Services, Centers for Disease Control and Prevention, National Institute for Occupational Safety and Health, DHHS (NIOSH) Publication No. 94-113 [www.cdc.gov/niosh/nmam/].
- [3] Lipari F, Swarin S. [1982]. Determination of formaldehyde and other aldehydes in automobile exhaust with an improved 2,4-dinitrophenylhydrazine method. *J Chromatogr* 247: 297-306.
- [4] Elia VJ, Messmer RA [1992]. Evaluation of method for estimating formaldehyde released from resin-containing paper and wood product dusts. *Am Ind Hyg Assoc J* 53: 632-638.
- [5] ACGIH [1985]. Particle Size Selective Sampling in the Workplace: Report of the ACGIH technical committee on air sampling procedures. Cincinnati, OH. American Conference of Governmental Hygienists.
- [6] NIOSH [1981]. NIOSH/OSHA occupational health guidelines for occupational hazards. Cincinnati, OH: U. S. Department of Health and Human Services, Centers for Disease Control, National Institute for Occupational Safety and Health, DHHS (NIOSH) Publication No. 81-123.

- [7] NIOSH [1994]. Particulate not otherwise regulated, total: Method 0500. In: Eller PM, Cassinelli ME, eds. NIOSH manual of analytical methods. 4th ed. Cincinnati, OH: U.S. Department of Health and Human Services, Centers for Disease Control and Prevention, National Institute for Occupational Safety and Health, DHHS (NIOSH) Publication No. 94-113 [www.cdc.gov/niosh/nmam/].
- [8] Nash T [1953]. The colorimetric estimation of formaldehyde by means of the Hantzsch reaction. *Biochem J* 55:416.

METHOD WRITTEN BY:

Y.T. Gagnon and E.R. Kennedy, NIOSH

APPENDIX: Preparation and Standardization of Formaldehyde Stock Solution (ca. 1 mg/mL)

Dilute 2.7 mL 37% aqueous formalin solution to 1 L with distilled, deionized water. This solution is stable for at least three months. Standardize by placing 5.0 mL of freshly prepared 1.13 M sodium sulfite solution in a 50-mL beaker and stir magnetically. Adjust pH to between 8.5 and 10 with base or acid. Record the pH. Add 10.0 mL formaldehyde stock solution. The pH should now be greater than 11. Titrate the solution back to its original pH with 0.02 N sulfuric acid (1 mL acid = 0.600 mg formaldehyde; about 17 mL acid needed). If the endpoint pH is overrun, back-titrate to the endpoint with 0.01 N sodium hydroxide. Calculate the concentration, C_s (mg/mL), of the formaldehyde stock solution:

$$C_s = \frac{30.0(N_a V_a - N_b V_b)}{V_s}$$

where: 30.0 = 30.0 g/equivalent of formaldehyde

N_a = normality of sulfuric acid (0.02 N)

V_a = volume of sulfuric acid (mL) used for titration

N_b = normality of NaOH (0.01 N)

V_b = volume of NaOH (mL) used for back-titration

V_s = volume of formaldehyde stock solution (10.0 mL)

Alternate Analysis Procedure for the Determination of Formaldehyde Liberated from Dust/Fiber Samples

NOTE: This analysis procedure should only be used where interferences to the chromotropic acid analysis are not present. These interferences include phenol, oxidizable organic material, other aldehydes and alcohols.

For formaldehyde determination by the chromotropic acid method, a 4-mL aliquot of the solution resulting from the desorption and incubation of the filter (step 8.) was analyzed by the procedure described in NIOSH Method 3500 [2]. The amount of chromotropic acid added to the sample could react with a maximum of 42 μg of formaldehyde per sample aliquot. (Whenever the amount of formaldehyde approached 30 μg per aliquot, the sample was diluted and reanalyzed.) The absorbance of samples at 580 nm was then compared to a calibration curve constructed from results obtained from analysis of calibration standards containing known amounts of formaldehyde. The amount of formaldehyde present in each sample was determined based on the calibration curve.

Calibration standards were prepared by dilution of a standard solution of formalin in distilled water (1 mg/mL) and analyzed in the same manner as the samples. The calibration range usually covered 1 to 25 μg of formaldehyde/4-mL aliquot. A limit of detection of 0.44 μg formaldehyde/filter sampler was determined in laboratory evaluation of this analysis procedure.

Disclaimer: Mention of any company or product does not constitute endorsement by NIOSH. In addition, citations to websites external to NIOSH do not constitute NIOSH endorsement of the sponsoring organizations or their programs or products. Furthermore, NIOSH is not responsible for the content of these websites. All web addresses referenced in this document were accessible as of the publication date.

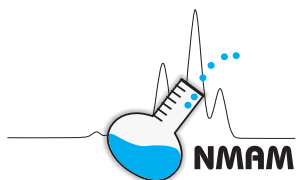

AsH₃ MW: 77.95 CAS: 7784-42-1 RTECS: CG6475000

METHOD: 6001, Issue 3

EVALUATION: FULL

Issue 1: 15 May 1985

Issue 3: 20 October 2015

OSHA: 0.05 ppm (0.2 mg/m³)
NIOSH: C 0.002 mg/m³ (15 min); carcinogen

PROPERTIES: Gas; d 3.484 g/L @ 20 °C; BP -62.5 °C; MP -116.3 °C

SYNONYMS: Hydrogen arsenide; arsenic trihydride

| SAMPLING | | MEASUREMENT | |
|---|--|---|--|
| SAMPLER: SOLID SORBENT TUBE (coconut shell charcoal, 100 mg/50 mg) | | TECHNIQUE: ATOMIC ABSORPTION, GRAPHITE FURNACE | |
| FLOW RATE: 0.01 L/min to 0.2 L/min | | ANALYTE: Arsenic | |
| VOL-MIN: 0.1 L @ 0.05 ppm -MAX: 10 L | | DESORPTION: 1 mL 0.01 mol/L nitric acid; 30 min in ultrasonic bath | |
| SHIPMENT: Routine | | MATRIX MODIFIER: Nickel, 1000 µg/mL | |
| SAMPLE STABILITY: At least 6 d @ 25 °C [1] | | WAVELENGTH: 193.7 nm; deuterium or hydrogen correction | |
| BLANKS: 2 to 10 field blanks per set | | GRAPHITE FURNACE: DRY: 40 s @ 110 °C; CHAR: 15 s @ 1200 °C; ATOMIZE: 7 s @ 2540 °C | |
| ACCURACY | | INJECTION: 50 µL | |
| RANGE STUDIED: 0.09 mg/m ³ to 0.4 mg/m ³ [1] (10 L samples); 0.001 mg/m ³ to 0.01 mg/m ³ [2] | | CALIBRATION: Arsenic in 0.01 mol/L nitric acid with 100 mg charcoal present | |
| BIAS: -6.13% at 0.01 L/min to 0.2 L/min flow rates [1]; -11% @ 0.876 L/min [2] | | RANGE: 0.01 µg to 0.3 µg per sample [2] | |
| OVERALL PRECISION (\hat{S}_{pr}): 0.087 [2] | | ESTIMATED LOD: 0.004 µg per sample | |
| ACCURACY: ±23.2% | | PRECISION (\bar{S}_r): 0.060 @ 0.012 µg to 0.11 µg per sample [2] | |

APPLICABILITY: The working range is 0.0003 ppm to 0.06 ppm (0.001 mg/m³ to 0.2 mg/m³) for a 10 L air sample. This is an elemental analysis and is not compound-specific.

INTERFERENCES: Use background correction to control molecular absorption. Other arsenic compounds (gases or aerosols) may be collected on the sampler and would be erroneously reported as arsine. A cellulose ester filter in front of the charcoal tube may be used to remove aerosols [3,4]. The effect of relative humidity on the capacity of charcoal for arsine has not been studied.

OTHER METHODS: This method combines and replaces NIOSH methods P&CAM 265 [5] and S229 [6] for arsine.

REAGENTS:

1. Water, distilled or deionized.
2. Nitric acid, concentrated.*
3. Nitric acid, 0.01 mol/L. Dilute 0.4 mL concentrated nitric acid to 1 L with water.
4. Nitric acid, 0.1 mol/L. Dilute 4 mL concentrated nitric acid to 1 L with water.
5. Arsenic stock solution, 1000 µg/mL arsenic.* Commercial standard or dissolve 1.322 g dried, certified reagent arsenic trioxide in 100 mL of 0.1 mol/L nitric acid; dilute to 1 L with 0.1 mol/L nitric acid.
6. Calibration stock solution, 1.0 µg/mL arsenic.* Dilute 0.1 mL arsenic stock solution (1000 µg/mL arsenic) to 100 mL with 0.01 mol/L nitric acid. Prepare fresh daily.
7. Nickel nitrate solution, 1000 µg/mL nickel. Commercial nickel atomic absorption standard or dissolve 3.112 g dried reagent nickel nitrate in 100 mL of 0.1 mol/L nitric acid; dilute to 1 L with water.
8. Argon, compressed.*
9. Arsine,* 99%, or certified mixture in nitrogen.

*See SPECIAL PRECAUTIONS.

EQUIPMENT:

1. Sampler: Activated coconut shell charcoal (100 mg/50 mg sections, 20/40 mesh), in a glass tube, 7 cm long, 6 mm OD, 4 mm ID, with flame-sealed ends. A silylated glass wool plug precedes the front section and urethane foam plugs separate the sorbent sections and follow the back section.
NOTE: Use a cellulose ester membrane filter in front of the sampler if particulate arsenic is present [3,4].
2. Personal sampling pump, 0.01 L/min to 0.2 L/min, with flexible connecting tubing.
3. Graphite furnace atomic absorption spectrophotometer with non-pyrolytic tubes, background correction, and electrodeless discharge (and power supply) or hollow cathode lamp for arsenic.
4. Volumetric flasks, 1 L and 100 mL.[†]
5. Micropipets, 5 µL to 500 µL.[†]
6. Centrifuge tubes, 10 mL or 15 mL.[†]
7. Ultrasonic bath.
8. Centrifuge.
9. Syringe, gas, 0.1 mL, readable to 1 µL.

[†]Clean all glassware with concentrated nitric acid and rinse thoroughly with distilled or deionized water before use.

SPECIAL PRECAUTIONS: Arsenic is a human carcinogen [7]. Wear gloves, lab coat, and safety glasses while handling acids. Perform all concentrated acid handling in a fume hood. Arsine is extremely poisonous by inhalation. Handle in well-ventilated hood and wear appropriate protective clothing and gloves. Users must be familiar with the proper use of flammable and nonflammable gases, cylinders, and regulators.

SAMPLING:

1. Calibrate each personal sampling pump with a representative sampler in line.
2. Break the ends of the sampler immediately before sampling. Attach sampler to personal sampling pump with flexible tubing.
NOTE: Use a cellulose ester membrane prefilter if particulate arsenic compounds may be present [3,4].
3. Sample at an accurately known flow rate between 0.01 L/min and 0.2 L/min for a total sample size of 0.1 L to 10 L.
4. Cap the sampler with plastic (not rubber) caps and pack securely for shipment.

SAMPLE PREPARATION:

5. Place the front and back sorbent sections of the sampler tube in separate centrifuge tubes. Discard the glass wool and foam plugs.
6. Add 1.0 mL of 0.01 mol/L nitric acid to each tube. Cap each tube.

7. Agitate for 30 min in an ultrasonic bath.
8. Centrifuge each tube.

CALIBRATION AND QUALITY CONTROL:

9. Calibrate daily with at least six working standards over the range 0.004 µg to 0.3 µg arsenic per sample.
 - a. Add known amounts of calibration stock solution and 0.01 mol/L nitric acid for a 1.0 mL final solution volume to centrifuge tubes containing 100 mg activated charcoal from a media blank sampler.
 - b. Analyze standards together with samples and blanks (steps 12 and 13). Analyze a working standard for every five samples to check for instrument drift.
 - c. Prepare a calibration graph (absorbance vs. µg arsenic).
10. Determine desorption efficiency (DE) at least once for each batch of charcoal used for sampling in the range 0.004 µg to 2 µg arsenic per sample. Prepare three tubes at each of five levels plus three media blanks.
 - a. Remove and discard back sorbent section of a media blank sampler.
 - b. Inject a known amount of pure arsine gas (or a certified gas mixture containing arsine) directly onto front sorbent section with a microliter syringe.
 - c. Cap the tube. Allow to stand overnight.
 - d. Desorb (steps 5, 6, 7, and 8) and analyze together with working standards (steps 12 and 13).
 - e. Prepare a graph of DE vs. µg arsenic recovered.
11. Analyze three quality control spikes to ensure that the calibration graph is in control.

MEASUREMENT:

12. Set the spectrophotometer and furnace to manufacturer's recommendations and to conditions given on page 6001-1.
13. Inject a 50 µL aliquot of sample or standard followed by a 50 µL aliquot of nickel nitrate solution prior to initiating the analysis program. Measure peak area.

NOTE 1: If sample absorbance is above the linear range of the standards, dilute with 0.01 mol/L nitric acid, reanalyze and apply the appropriate dilution factor in calculations.

NOTE 2: Monitor the reproducibility of peak area for a working standard throughout the measurements. If erratic results occur, reoptimize instrumental parameters and replace the graphite tube.

CALCULATIONS:

14. Determine the mass, µg, of arsine found in the sample front (W_f) and back (W_b) sorbent sections, and in the average media blank front (B_f) and back (B_b) sorbent sections by multiplying the mass of arsenic found for each of these sections by 1.040 (MW of arsine/MW of arsenic).

NOTE: If $W_f > W_b / 10$, report breakthrough and possible sample loss.
15. Calculate concentration, C , of arsine in the air volume sampled, V (L):

$$C = \frac{W_f + W_b - B_f - B_b}{V}, \text{ µg/L or mg/m}^3.$$

EVALUATION OF METHOD:

NIOSH method S229 [6] was evaluated over the range 0.094 mg/m³ to 0.404 mg/m³ using 10 L air samples collected on SKC Lot 105 activated coconut charcoal [1]. Breakthrough (onto the backup section) did not occur after 240 min of sampling at 0.227 L/min from an arsine concentration of 0.405

mg/m³ (0.022 mg loading). The recovery was found to be 93.7%. Desorption efficiency was 0.90 at 1 µg arsine per sample and 1.00 at 2 µg and 4 µg arsine per sample.

NIOSH method P&CAM 265 [5] was evaluated over the range 0.001 mg/m³ to 0.01 mg/m³ using 15 L air samples [2]. These samples were collected on SKC Lot 106 activated coconut charcoal at a sampling flow rate of 0.875 L/min for 15 min. At this flow rate, a collection efficiency of 89.1% was found [3]. The effect of high humidity on the sampler capacity was not studied. Desorption efficiency was 0.90 in the range 0.015 µg to 0.2 µg arsine per sample.

REFERENCES:

- [1] NIOSH [1977]. Backup data report: arsine, No. S229. By Taylor DG, Kupel RE, Bryant JM. In: Documentation of the NIOSH validation tests. Cincinnati, OH: U.S. Department of Health, Education, and Welfare, Center for Disease Control, National Institute for Occupational Safety and Health, DHEW (NIOSH) Publication No. 77-185, available as accession No. PB274248 from NTIS [www.ntis.gov].
- [2] NIOSH [1977]. Evaluation and refinement of a personal sampling method for arsine. Cincinnati, OH: U.S. Department of Health, Education, and Welfare, Center for Disease Control, National Institute for Occupational Safety and Health, NIOSH research report, prepared under NIOSH Contract No. 210-76-0142. Unpublished.
- [3] Costello RJ, Eller PM, Hull RD [1983]. Measurement of multiple inorganic arsenic species. *Am Ind Hyg Assoc J* 44(1):21–28.
- [4] NIOSH [1994]. Arsenic and compounds, as As (except AsH₃ and As₂O₃): Method 7900; Arsenic trioxide, as As: Method 7901. In: Eller PM, Cassinelli ME, eds. NIOSH manual of analytical methods. 4th ed. Cincinnati, OH: U.S. Department of Health and Human Services, Centers for Disease Control and Prevention, National Institute for Occupational Safety and Health, DHHS (NIOSH) Publication No. 94-113 [www.cdc.gov/niosh/nmam/].
- [5] NIOSH [1978]. Arsine in air: P&CAM 265. In: Taylor DG, ed. NIOSH manual of analytical methods. 2nd ed. Vol. 4. Cincinnati, OH: U.S. Department of Health, Education, and Welfare, Center for Disease Control, National Institute for Occupational Safety and Health, DHEW (NIOSH) Publication No. 78-175, available as accession No. PB83-105437 from NTIS [www.ntis.gov].
- [6] NIOSH [1977]. Arsine: Method S229. In: Taylor DG, ed. NIOSH manual of analytical methods. 2nd ed. Vol. 3. Cincinnati, OH: U.S. Department of Health, Education, and Welfare, Center for Disease Control, National Institute for Occupational Safety and Health, DHEW (NIOSH) Publication No. 77-157-C, available as accession No. PB276838 from NTIS [www.ntis.gov].
- [7] NIOSH [1975]. Criteria for a recommended standard: occupational exposure to inorganic arsenic (new criteria - 1975). Cincinnati, OH: U.S. Department of Health, Education, and Welfare, Center for Disease Control, National Institute for Occupational Safety and Health, DHEW (NIOSH) Publication No. 75-149 [www.cdc.gov/niosh/docs/1970/75-149.html].

METHOD REVISED BY:

R. D. Hull, Ph.D., NIOSH/DBBS.

DISCLAIMER: Mention of any company or product does not constitute endorsement by NIOSH. In addition, citations to websites external to NIOSH do not constitute NIOSH endorsement of the sponsoring organizations or their programs or products. Furthermore, NIOSH is not responsible for the content of these websites. All web addresses referenced in this document were accessible as of the publication date.

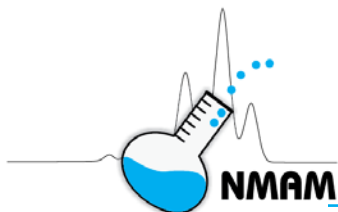

PHOSPHINE

6002

PH₃ MW: 34.00 CAS: 7803-51-2 RTECS: SY7525000

METHOD: 6002, Issue 3

EVALUATION: FULL

Issue 1: 15 August 1994

Issue 3: 20 October 2015

OSHA: 0.3 ppm (0.4 mg/m³)
NIOSH: 0.3 ppm (0.4 mg/m³); 1 ppm (1 mg/m³) STEL

PROPERTIES: Gas, BP 87.8 °C; vapor density 1.17 (air = 1); spontaneously flammable in air if diphosphane is present

SYNONYMS: Hydrogen phosphide; phosphorus hydride; phosphorated hydrogen; phosphorus trihydride

| SAMPLING | MEASUREMENT |
|--|---|
| <p>SAMPLER: SORBENT TUBE (mercuric cyanide-coated silica gel, 300 mg/150 mg)</p> <p>FLOW RATE: 0.01 L/min to 0.2 L/min</p> <p>VOL-MIN: 1 L @ 0.3 ppm -MAX: 16 L</p> <p>SHIPMENT: Routine</p> <p>SAMPLE STABILITY: 7 d @ 25 °C</p> <p>BLANKS: 2 to 10 field blanks per set</p> | <p>TECHNIQUE: UV-VIS SPECTROMETER</p> <p>ANALYTE: Phosphate</p> <p>EXTRACTION: 10 mL hot (65 °C to 70 °C) acidic permanganate reagent solution</p> <p>DETECTOR: UV @ 625 nm</p> <p>CALIBRATION: Standard solutions of potassium dihydrogen phosphate (1.00 mL contains phosphorus equivalent to 49.94 µg of phosphine)</p> <p>RANGE: 0.3 µg to 10 µg per sample [2]</p> |
| ACCURACY | <p>ESTIMATED LOD: 0.1 µg per sample [1]</p> <p>PRECISION (\hat{S}_r): 0.074 @ 2.6 µg to 17.4 µg per sample [2]</p> |
| <p>RANGE STUDIED: 0.195 mg/m³ to 0.877 mg/m³ [1] (16 L samples)</p> <p>BIAS: 0.4%</p> <p>OVERALL PRECISION (\hat{S}_r): 0.091 @ 2.64 µg to 17.41 µg per sample [2]</p> <p>ACCURACY: ±17.6%</p> | |

APPLICABILITY: The working range is 0.013 ppm to 0.6 ppm (0.02 mg/m³ to 0.9 mg/m³) for a 16 L air sample.

INTERFERENCES: The colorimetric determination of phosphate is subject to interference by any species that also forms a molybdate complex under these conditions; possible interfering species include phosphorus trichloride and phosphorus pentachloride vapors and organic phosphorus compounds.

OTHER METHODS: This revises NIOSH method S332 [2]. OSHA method 1003, "Phosphine" [3], employing a mercuric chloride-treated polyester filter used to capture phosphine and ICP-AES to analyze for the total phosphorus, may be used as an alternative method.

REAGENTS:

1. Potassium dihydrogen phosphate, anhydrous, ACS reagent grade.
2. Sulfuric acid,* concentrated, ACS reagent grade.
3. Ammonium molybdate tetrahydrate.
4. Ferrous ammonium sulfate, anhydrous.
5. Potassium permanganate.*
6. Stannous chloride.
7. Glycerol.
8. Toluene.*
9. Isobutanol.*
10. Methanol.*
11. Water, deionized or distilled.
12. Mercuric cyanide.*
13. Standard phosphate solution. Dissolve 200 mg anhydrous potassium dihydrogen phosphate in distilled water and dilute to 1 L (1.00 mL contains phosphorus equivalent to 49.94 µg of phosphine).
14. Molybdate solution. Dissolve 49.4 g of ammonium molybdate tetrahydrate and 112 mL concentrated sulfuric acid in distilled water and dilute to 1 L.
15. Alcoholic sulfuric acid solution. Add 50 mL of concentrated sulfuric acid to 950 mL methanol.
16. Toluene-isobutanol solvent. Mix equal volumes of toluene and isobutanol.
17. Ferrous solution. Dissolve 7.9 g anhydrous ferrous ammonium sulfate and 1 mL concentrated sulfuric acid in distilled water and dilute to 100 mL.
18. Stannous chloride solution. Dissolve 0.4 g stannous chloride in 50 mL glycerol (heat to dissolve).
19. Acidic permanganate solution. Dissolve 0.316 g potassium permanganate and 6 mL concentrated sulfuric acid in distilled water and dilute to 1 L.
20. Mercuric cyanide solution.* Dissolve 2 g mercuric cyanide in 100 mL water.

*See SPECIAL PRECAUTIONS.

EQUIPMENT:

1. Sampler: Sorbent tube, silica gel (mercuric cyanide), 300 mg/150 mg sorbent, 40/60 mesh; or, glass tube 12 cm long, 6 mm O.D., 4 mm I.D., flame-sealed ends with plastic caps, with two sections of mercuric cyanide-treated silica gel (45/60 mesh), (front = 300 mg, back = 150 mg), separated and retained by silylated glass wool plugs. (See APPENDIX.)
2. Personal sampling pump, 0.01 L/min to 0.2 L/min, with flexible polyethylene or PTFE tubing.
3. Spectrometer capable of measuring absorbance or transmittance at 625 nm.
4. Two matched 5 cm absorbance cells, silica, with tight fitting caps.
5. Separatory funnel, 125 mL.
6. Beakers, 50 mL.
7. Pipets, 0.2 mL, 10 mL, and 25 mL, and other convenient sizes to make standard dilutions.
8. Volumetric flasks, 10 mL, 25 mL, 100 mL, and 1000 mL.
9. Water bath (maintained at 65 °C to 70 °C).
10. Graduated cylinders, glass, 10 mL.
11. Syringes, 0.5 mL and 1.0 mL.
12. Balance.
13. Thermometer.
14. Stopwatch.
15. Barometer.

SPECIAL PRECAUTIONS: Caution should be exercised when preparing the sampling media because mercuric cyanide is toxic by inhalation, ingestion, and skin contact. Contact of mercuric cyanide with acid will produce hydrogen cyanide gas. Concentrated sulfuric acid is highly corrosive. All work with these compounds should be performed in a hood. Use proper protective clothing including gloves, safety glasses, and laboratory coat. Potassium permanganate is a strong oxidizer with risk of fire and explosion upon contact with combustible substances and reducing agents. Toluene, isobutanol, and methanol are flammable.

SAMPLING:

1. Calibrate each personal sampling pump with a representative sampler in line.
2. Immediately before sampling, break the ends of the silica gel tubes to provide an opening of at least one half the internal diameter of the tube. Attach the silica gel tube to the sampling pump with flexible tubing.
3. Sample at an accurately known flow rate between 0.01 L/min and 0.2 L/min for a total sample size of 1 L to 16 L.
4. Seal tubes with plastic (not rubber) caps.

SAMPLE PREPARATION:

5. Place front and back sorbent sections in separate 50 mL beakers.
6. Add 10 mL of acidic permanganate solution to each beaker. Place in a water bath maintained at 65 °C to 70 °C for 90 min.
7. Decant the acidic permanganate solution into a 10 mL volumetric flask, and dilute to volume with distilled water.
8. Wash the silica gel twice with 3 mL portions of distilled water and decant the contents into another 10 mL volumetric flask containing 1 mL of ferrous solution. Dilute to volume with distilled water.
9. Add the contents of both 10 mL volumetric flasks (extract and washings) to a 125 mL separatory funnel.
10. Add 7.5 mL of molybdate reagent and 25 mL of toluene-isobutanol solvent to the funnel. Shake funnel for 60 s. Let the separatory funnel stand for 60 s to allow the aqueous and nonaqueous layers to separate. Discard the lower (aqueous) layer.
11. Pipet 10 mL of the nonaqueous layer into a 25 mL volumetric flask containing 10 mL of the alcoholic sulfuric acid solution.

CALIBRATION AND QUALITY CONTROL:

12. Calibrate daily with at least six working standards.
 - a. Add 10 mL of acidic permanganate solution and 1 mL of ferrous reagent to a 125 mL separatory funnel.
 - b. Add 2 µL to 400 µL of the standard phosphate solution to cover the range 0.1 µg to 10 µg of phosphine. Add 8 mL to 9 mL of water to make the total volume of the solution (permanganate solution, ferrous solution, phosphate solution and water) equal to 20 mL. Prepare at least six calibration standards and a blank containing no phosphate.
 - c. Add 7.5 mL of molybdate reagent and 25 mL of toluene-isobutanol solvent to the funnel. Shake funnel for 60 s. Let the separatory funnel stand for 60 s to allow the aqueous and nonaqueous layers to separate. Discard the lower (aqueous) layer. (step 10)
 - d. Pipet 10 mL of the nonaqueous layer into a 25 mL volumetric flask containing 10 mL of the alcoholic sulfuric acid solution. (step 11)
 - e. Analyze with samples and blanks (steps 15, 16, 17, and 18).
 - f. Prepare a calibration graph (absorbance versus µg of phosphine added).
13. Determine desorption efficiency (DE) at least once for each lot of sorbent used for sampling in the range of interest. Prepare three tubes at each of five levels plus three media blanks.
 - a. Remove and discard back sorbent section of a media blank sampler.
 - b. Inject a known amount (20 µL to 400 µL) of standard phosphate solution directly onto front sorbent section with a microliter syringe.
 - c. Cap the tube. Allow to stand overnight.
 - d. Desorb (steps 6, 7, and 8) and analyze with working standards (steps 15, 16, 17, and 18).
 - e. Prepare a graph of DE vs. µg recovered.

- Analyze three quality control blind spikes and three analyst spikes to ensure that the calibration graph and DE graph are in control.

MEASUREMENTS

- Turn on the spectrophotometer and allow sufficient time for warmup. Adjust the wavelength to 625 nm and set the zero and 100% transmittance scale using 5 cm cells filled with distilled water. Check these settings prior to making any measurement to check on instrument drift.

NOTE: Steps 16, 17, and 18 must be performed within 1 min.

- Add 0.5 mL (25 drops) of stannous chloride reagent and dilute to volume using alcoholic sulfuric acid solution. Mix thoroughly.
- Transfer the sample into a 5 cm cell and stopper immediately.
- Measure the absorbance or transmittance using water as a blank.

CALCULATIONS:

- Determine mass, μg (corrected for DE), of phosphine found in the sample front (W_f) and back (W_b) sorbent sections, and in the average media blank front (B_f) and back (B_b) sorbent sections.

NOTE: If $W_f > W_b / 10$, report breakthrough and possible sample loss.

- Calculate concentration, C , of phosphine in the air volume sampled, V (L).

$$C = \frac{W_f + W_b - B_f - B_b}{V}, \mu\text{g/L or mg/m}^3.$$

EVALUATION OF METHOD:

This method was validated over the range 0.195 mg/m³ to 0.877 mg/m³ at 19 °C and 102.0 kPa (765.3 mmHg) using 16 L samples [1]. Desorption efficiency must be determined over the range used. The upper range of the method depends on the adsorptive capacity of the mercuric cyanide-treated gel. This capacity may vary with the concentration of phosphine and other substances in the air. When an atmosphere at 90% relative humidity containing 0.957 mg/m³ of phosphine was sampled at a flow rate of 0.2 L/min, breakthrough was determined to occur at a sample volume of 20.75 liter (capacity = 19.86 μg phosphine).

REFERENCES:

- NIOSH [1979]. Backup data report: phosphine, No. S332. In: Ten NIOSH analytical methods, set 7. Cincinnati, OH: U.S. Department of Health, Education, and Welfare, Center for Disease Control, National Institute for Occupational Safety and Health, available as accession No. PB84-243534 from NTIS [www.ntis.gov]. Unpublished.
- NIOSH [1979]. Phosphine: Method S332. In: Taylor DG, ed. NIOSH manual of analytical methods. 2nd ed. Vol. 5. Cincinnati, OH: U.S. Department of Health, Education, and Welfare, Center for Disease Control, National Institute for Occupational Safety and Health, DHEW (NIOSH) Publication No. 79-141, available as accession No. PB83-105445 from NTIS [www.ntis.gov].
- OSHA [2000]. Phosphine: OSHA Method 1003 [www.osha.gov/dts/sltc/methods/mdt/mdt1003/1003.html]. Date accessed: October 2015.

METHOD REVISED BY:

Charles Lorberau, NIOSH/DPSE.

DISCLAIMER: Mention of any company or product does not constitute endorsement by NIOSH. In addition, citations to websites external to NIOSH do not constitute NIOSH endorsement of the sponsoring organizations or their programs or products. Furthermore, NIOSH is not responsible for the content of these websites. All web addresses referenced in this document were accessible as of the publication date.

APPENDIX: PREPARATION OF SAMPLING MEDIA

Coating of Silica Gel

1. Dry 100 g of silica gel (45/60 mesh) at 90 °C for 2 h.
2. Prepare a mercuric cyanide solution in distilled water (2 g mercuric cyanide in 100 mL water).
3. Add the dried silica gel to the mercuric cyanide solution and let set for 15 min with occasional stirring.
4. Drain the excess mercuric cyanide solution and dry the remaining silica gel at 90 °C for 3 h.
5. Cool the silica gel to room temperature in a covered beaker.
6. Expose the silica gel to a humid atmosphere (>80% RH) for 24 h.

Preparing the Sampling Tubes

7. Place a plug of silylated glass wool at the end of a glass tube (6 mm OD and 4 mm ID) about 12 cm long. Pour 300 mg of the treated silica gel into the tube. Place another plug of silylated glass wool behind this front section. Add another 150 mg of the treated silica gel into the tube. Place a final plug of silylated glass wool behind this backup section.
8. Check the pressure drop of a representative sampler. The pressure drop across the tube must be less than 6.7 kPa (50 mmHg) at a flow rate of 0.2 L/min.
9. Flame seal both ends of the sampling tubes.



HYDROGEN CYANIDE

6010

HCN

MW: 27.03

CAS: 74-90-8

RTECS: MW6825000

METHOD: 6010, Issue 3

EVALUATION: FULL

Issue 1: 16 May 1989

Issue 3: 30 June 2017

OSHA: 10 ppm (11 mg/m³) (skin)
NIOSH: STEL 4.7 ppm (5 mg/m³) (skin)
IDLH: 50 ppm [1]
OTHER OELs: Refs. [2, 3]

PROPERTIES: gas; BP 26 °C, vapor density 0.93 (air = 1.00);
 d(liq) 0.69 g/mL @ 20 °C, VP 82.7 kPa (620 mm Hg @ 20 °C);
 explosive range 5 to 40% v/v in air

SYNONYMS: Hydrocyanic acid, prussic acid, formonitrile

| SAMPLING | | MEASUREMENT | |
|---|--|--|--|
| SAMPLER: | SOLID SORBENT TUBE (soda lime, 600 mg/200 mg), with glass fiber pre-filter | TECHNIQUE: | SPECTROPHOTOMETRY, visible absorption |
| FLOW RATE: | 0.025 to 0.05 L/min | ANALYTE: | cyanide ion complex |
| VOL-MIN: | 2 L @ 5 ppm | DESORPTION: | 10 mL deionized water; stand 60 min |
| -MAX: | 90 L | COLOR DEVELOPMENT: | N-chlorosuccinimide/succinimide oxidizing agent and barbituric acid/pyridine coupling agent; absorption @ 580 nm in 1-cm cuvette |
| SHIPMENT: | routine | CALIBRATION: | standard solutions of KCN in 1 M NaOH |
| SAMPLE STABILITY: | at least two weeks at 25 °C [4] | RANGE: | 10 to 300 µg CN ⁻ per sample [4] |
| BLANKS: | 3 field blanks min. per set | ESTIMATED LOD: | 1 µg CN ⁻ per sample [4] |
| ACCURACY | | PRECISION (\bar{S}_r): | 0.041 @ 10 to 50 µg CN ⁻ per sample [4] |
| RANGE STUDIED: | 2 to 15 mg/m ³ (3-L samples) [4] | | |
| BIAS: | negligible | | |
| OVERALL PRECISION (\hat{S}_{rT}): | 0.076 [4] | | |
| ACCURACY: | ±15% | | |

APPLICABILITY: The method is applicable to STEL measurements of HCN gas. The working range is 0.3 to 235 ppm (3 to 260 mg/m³) for a 3-L air sample. Particulate cyanides are trapped by an initial glass fiber filter (pre-filter) that precedes the sorbent tube. This method is more sensitive and subject to fewer interferences than NIOSH Method 7904 [5], which uses ion specific electrode analysis. The method has been used to measure HCN in firefighting environments [6].

INTERFERENCES: A high concentration of hydrogen sulfide (H₂S) can cause a negative interference by reaction with cyanide to form thiocyanate.

OTHER METHODS: The procedure is based on the method of Lambert et al. [7]. NIOSH Method 7904 relies on the use of ion selective electrodes for measurement of CN⁻ [5]. A related method, which employs diffusive sampling onto soda lime sorbent, followed by desorption and ion chromatography with electrochemical detection, has been promulgated by OSHA [8].

REAGENTS:

1. Potassium cyanide,* reagent grade.
2. Succinimide, reagent grade.
3. N-Chlorosuccinimide, reagent grade.
4. Barbituric acid, reagent grade.
5. Pyridine, spectroscopic quality.
6. Phenolphthalein, 1% (w/v) in ethanol or methanol, reagent grade.
7. Hydrochloric acid, conc., reagent grade.
8. Sodium hydroxide, reagent grade.
9. Soda lime (CaO + 5-20% NaOH), reagent grade. Crush and sieve to 10/35 mesh; store in a sealed container.
10. Water, deionized (18 M Ω -cm).
11. NaOH solution, 0.1 M.
12. Calibration stock solution, 1 mg/mL CN:
Dissolve 0.125 g KCN in \approx 40 mL 0.1 M NaOH in a 50-mL volumetric flask. Dilute to the mark with 0.1 M NaOH. Standardize by titration with AgNO₃ (see APPENDIX).
13. HCl solution, 0.15 M.
14. N-Chlorosuccinimide/succinimide oxidizing reagent: Dissolve 10.0 g succinimide in \approx 200 mL deionized (DI) water. Add 1.00 g N-chlorosuccinimide; agitate to dissolve. Adjust volume to 1 L with DI H₂O. Solution is stable for 6 months when kept at \approx 4 °C.
15. Barbituric acid/pyridine reagent: Add \approx 30 mL DI H₂O to 6.0 g barbituric acid in a 100-mL Erlenmeyer flask. Slowly add 30 mL pyridine with stirring. Adjust volume to 100 mL with DI H₂O. Solution is stable for 2 months when kept at \approx 4 °C.

*See SPECIAL PRECAUTIONS.

EQUIPMENT:

1. Sampler: glass tube, length 9 cm, 7-mm OD/5-mm ID, with plastic caps, containing two sorbent sections of granular soda lime 10/35 mesh (front = 600 mg; back = 200 mg), separated by and contained within silanized glass wool plugs. A 5-mm dia. glass fiber filter is placed before the inlet.
NOTE: Tubes are commercially available.
2. Spectrophotometer, Visible (580 nm), with 1-cm light path cuvettes.
3. Personal sampling pump, 0.025-0.05 L/min, with flexible connecting tubing.
4. Pipets, volumetric, 0.1-, 0.5-, 1.0-, 2.0-, 10.0-mL.
5. Vials, glass or plastic, 15-mL, with polytetrafluoroethylene (PTFE)-lined caps.
6. Flasks, volumetric, 25-, 50-, 100-, and 1000-mL, with stoppers.
7. Pipets, transfer, disposable.
8. Laboratory wipes.
9. Syringes, 10-mL, polyethylene with Luer tip readable to 0.1 μ L.
10. Flask, Erlenmeyer, 100-mL.
11. Luer-lock PTFE membrane filters, 13-mm dia., 0.45- μ m pore size, to fit onto 10-mL syringes.

SPECIAL PRECAUTIONS: HCN gas and cyanide are highly toxic and may be fatal if swallowed, inhaled or absorbed through skin [1]. Soda lime and NaOH are very caustic [1]. Wear appropriate personal protection during sampling activities and analysis. It is essential that suitable gloves, eye protection, laboratory coat, etc., be used when working with these chemicals. Perform sample preparation and analysis in a clean, well-ventilated area that is well removed from any possible contamination.

SAMPLING:

1. Calibrate each personal sampling pump with a representative sampler in the line.
2. Break both ends of the sampling tube immediately prior to sampling. Attach the glass fiber filter to the inlet of the sorbent tube. Attach sampler to personal sampling pump with flexible tubing.
3. Sample at an accurately known flow rate between 0.025 and 0.05 L/min (e.g., 0.033 L/min) for a total sample size of 0.6 to 90 L.

- Remove the sorbent tube from the sampling apparatus, cap both ends and pack securely for shipment to the laboratory. Discard the pre-filter.

SAMPLE PREPARATION:

- Score each sample tube with a file and break sampler at the score line.
- Transfer front and back sorbent sections to separate 15-mL vials. Discard glass wool plugs.
- Add 10.0 mL DI H₂O to each vial containing a sorbent section. Seal each vial.
- Allow to stand 60 min. with occasional agitation. Transfer to a 10-mL plastic syringe fitted with a 0.45- μ m PTFE filter, and collect the filtrate in a clean vial.

CALIBRATION AND QUALITY CONTROL:

- Calibrate daily with at least six working standard solutions over the range 1 to 300 μ g CN⁻ per sample.
 - Prepare a working standard solution, 1.00 μ g/mL CN⁻, by diluting 100 μ L of calibration stock solution to 100 mL with 0.1 M NaOH.
 - Pipet 0.50, 1.00, 1.50, 2.00, and 2.50 mL of the working standard solution into 25-mL volumetric flasks to make up 0.50-, 1.00-, 1.50-, 2.00-, and 2.50- μ g CN⁻ standards.
 - Analyze together with field samples and blanks (steps 12 through 19).
 - Prepare calibration graph (absorbance vs. μ g CN⁻).
- Determine desorption efficiency (DE) at least once for each lot of soda lime used for sampling. Prepare at least three tubes at each of five levels plus three media blanks.
 - Remove and discard back sorbent section of an unused (blank) sampler.
 - Inject a known amount of calibration stock solution directly onto the soda lime with a microliter syringe.
 - Cap and allow to stand overnight.
 - Desorb (steps 5 through 8) and analyze together with working standards and blanks (steps 12 through 18).
 - Prepare a graph of DE vs. μ g CN⁻ recovered.
- Analyze at least three quality control blind spikes and at least three analyst spikes to ensure that the calibration graph and DE graph are in control.

MEASUREMENT:

- Set spectrophotometer to record absorbance at 580 nm.
- Pipet a sample aliquot estimated to contain 0.5 to 2.5 μ g CN⁻ into a 25-mL volumetric flask. Alternatively, to cover an unknown sample range, pipet 0.50-, 1.00- and 3.00-mL aliquots into separate 25-mL volumetric flasks for each field sample. Larger or smaller aliquots may be taken, based on prior knowledge of the expected analyte level.
- Pipet 0.5 mL 0.1 M NaOH into a 25-mL volumetric flask for each standard or sample.
- Add one drop of phenolphthalein solution to each standard and sample.
NOTE: Add a small portion of DI H₂O to increase volume for easier mixing. All solutions should be alkaline (pink) at this juncture.
- Starting with the reagent blank, add 0.15 M HCl dropwise, with mixing, until reaching the point at which the pink color just disappears. CAUTION: HCN may be produced, so this step must be carried out in a fume hood. Immediately add 1.0 mL N-chlorosuccinimide/succinimide oxidizing reagent. Mix and let stand.
NOTE 1: To avoid possible loss of HCN, add the oxidizing agent before proceeding to the next sample.
NOTE 2: Do not prepare more samples than can be analyzed within the 30-minute maximum time for color development.
- After at least 5 min. standing (but not longer than 15 min.), starting with the reagent blank, add 1.0 mL of barbituric acid/pyridine coupling reagent and mix.

18. Adjust sample volume to 25 mL with DI H₂O and allow to stand for at least 12 min (but no longer than 30 min.) for color development.
19. Using the spectrophotometer, read the absorbance at 580 nm using a 1-cm light path cuvette. If sample absorbance is outside the range of the calibration standards, remove an aliquot, dilute and reanalyze. Apply appropriate dilution factor in calculations.

CALCULATIONS:

20. From the absorbance readings, calculate the mass of CN⁻ (μg) in each aliquot analyzed. Apply the appropriate dilution factor to calculate the mass of CN⁻ (μg) in the original 10-mL solution.
21. Determine the mass of CN⁻ (μg), corrected for desorption efficiency (DE), found in the front (W_f) and back (W_b) sections of the sorbent tube. Also determine the average background mass of media blank front (B_f) and back (B_b) sorbent sections. If W_b > W_f/10, report breakthrough and possible sample loss.
22. Calculate the concentration, C, of HCN in the air volume sampled, V(L):

$$C = \frac{(W_f + W_b - B_f - B_b) * 1.039}{V}, \text{ mg/m}^3$$

(where 1.039 = conversion factor for CN⁻ to HCN).

EVALUATION OF METHOD:

The method was initially evaluated by sampling test atmospheres of HCN generated from a compressed gas mixture of HCN in nitrogen [4]. The range of HCN concentrations was equivalent to 2 to 15 mg/m³ for a 3-L air sample. For 22 samples, an overall precision \hat{S}_{rT} of 0.076 was obtained with nearly 100% recovery. Breakthrough was observed to occur at [HCN] \approx 150 mg/m³ for sample volumes \approx 10 L. Sample tubes spiked with KCN standard solutions (n=22) in the range of 10 to 50 μg per sample indicated recoveries of nearly 100% with a pooled precision \bar{S}_r of 0.041. Sample tubes similarly spiked with KCN solutions were analyzed after storage and demonstrated that the samples were stable for at least two weeks. Sample collection of [HCN] in nitrogen of 130 mg/m³ at 50 mL/min for 7.3 minutes (0.36 L sample volume) resulted in quantitative recoveries [9]. Further evaluation of the method was carried out in test atmospheres of HCN generated in air of low (20%) and high (80%) relative humidity [9]. It was found that a sampling rate of 50 mL/min resulted in quantitative recoveries for HCN concentrations at 0.1 – 2× the OSHA PEL, while sampling at 200 mL/min gave recoveries <90% in this concentration range; similar results were obtained for both low and high humidity conditions. In consideration of these observations, the maximum sampling flow rate recommended for the method is 0.05 L/min.

REFERENCES:

- [1] NIOSH [2016]. NIOSH Pocket guide to chemical hazards. Cincinnati, OH: U.S. Department of Health and Human Services, Centers for Disease Control and Prevention, National Institute for Occupational Safety and Health, DHHS (NIOSH) Publication No. 2010-168c, <http://www.cdc.gov/niosh/npg/>.
- [2] ACGIH [2017] TLVs and BEIs based on the documentation of the Threshold Limit Values for chemical substances and physical agents and Biological Exposure Indices. Cincinnati, OH: American Conference of Governmental Industrial Hygienists.
- [3] Institute for Occupational Safety and Health of the German Social Accident Insurance (IFA) [2017]. GESTIS international limit values, <http://limitvalue.ifa.dguv.de/>.
- [4] Williamson G [1988]. Method development protocol and backup data report on hydrogen cyanide, internal report. Cincinnati, OH: NIOSH. Unpublished.

- [5] NIOSH [1994]. Method 7904 – Cyanide, aerosol and gas. In: Schlecht PC, O'Connor PF, eds. NIOSH manual of analytical methods. 4th ed. Cincinnati, OH: U.S. Department of Health and Human Services, Centers for Disease Control and Prevention, National Institute for Occupational Safety and Health, DHHS (NIOSH) Publication No. 94-113.
- [6] Williamson G [1988]. Analysis of air samples on project 166 (Fire smoke) on HCN, sequence report 6366-A. Cincinnati, OH: NIOSH. Unpublished.
- [7] Lambert JL, Ramasamy J, Paukstelis JV [1975]. Stable reagents for the colorimetric determination of cyanide by modified König reactions. *Anal Chem* 47:916-918.
- [8] OSHA [2010]. Method no. 1015 (HCN). In: OSHA sampling and analytical methods manual. Sandy, UT: U.S. Department of Labor, Occupational Safety and Health Administration, <http://www.osha.gov/dts/sltc/methods>.
- [9] Simmons M [2010]. Use of active sorbent soda lime tube for the collection of hydrogen cyanide, internal report. Sandy, UT: Department of Labor, Occupational Safety and Health Administration. Unpublished.

METHOD AUTHORED BY:

George Williamson, NIOSH/DART (ret.)

REVISED BY:

Kevin Ashley, NIOSH and Mike Simmons, OSHA/SLTC

Disclaimer: Mention of any company or product does not constitute endorsement by NIOSH. In addition, citations to websites external to NIOSH do not constitute NIOSH endorsement of the sponsoring organizations or their programs or products. Furthermore, NIOSH is not responsible for the content of these websites. All web addresses referenced in this document were accessible as of the publication date.

APPENDIX: STANDARDIZATION OF CYANIDE CALIBRATION STOCK SOLUTION

Titrate an aliquot of the cyanide standard stock solution (KCN in NaOH) with standard silver nitrite (AgNO_3) solution. The end point is the first formation of a white precipitate, $\text{Ag}[\text{Ag}(\text{CN})_2]$. Calculate the cyanide concentration by using the following equation:

$$M_c = 52.04 * V_a * \left(\frac{M_a}{V_c}\right)$$

where: M_c = cyanide concentration (mg/mL)
 V_a = volume (mL) of standard AgNO_3 solution
 M_a = concentration (moles/L) of standard AgNO_3 solution
 V_c = volume (mL) of cyanide calibration stock solution titrated

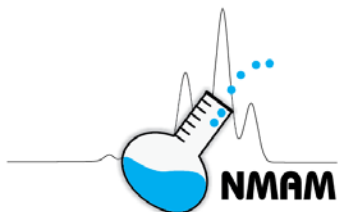

SULFURYL FLUORIDE

6012

SO₂F₂ MW: 102.06 CAS: 2699-79-8 RTECS: WT5075000

METHOD: 6012, Issue 2

EVALUATION: FULL

Issue 1: 15 August 1994

Issue 2: 12 January 2016

OSHA: 5 ppm
 NIOSH: 5 ppm; STEL 10 ppm
 (1 ppm = 4.17 mg/m³ @ NTP)

PROPERTIES: Gas; BP -55 °C; vapor density (air = 1) 3.5;
 VP 1.7 × 10³ kPa; nonflammable, colorless,
 odorless [1]

SYNONYMS: Sulfonyl difluoride, sulfur difluoride dioxide, sulfuric oxyfluoride

| SAMPLING | | MEASUREMENT | |
|---|--|--|--|
| SAMPLER: SOLID SORBENT TUBE (coconut shell charcoal, 800 mg/200 mg) | | TECHNIQUE: ION CHROMATOGRAPHY CONDUCTIVITY DETECTION | |
| FLOW RATE: 0.05 L/min to 0.1 L/min | | ANALYTE: Fluoride ion | |
| VOL-MIN: 1.3 L @ 5 ppm -MAX: 10 L | | EXTRACTION: 20 mL 40 mmol/L sodium hydroxide; sonicate 60 min | |
| SHIPMENT: Ship at 0 °C | | INJECTION: 50 µL | |
| SAMPLE STABILITY: At least 12 d @ 0 °C | | ELUENT: 40 mmol/L sodium hydroxide, 1.0 mL/ min | |
| BLANKS: 2 to 10 field blanks per set | | COLUMN: US Pharmacopeia (USP) L12 separator column, manufacturer's compatible anion guard column, and micromembrane suppressor as recommended by the manufacturer. See OTHER METHODS. | |
| ACCURACY | | DETECTOR: Conductivity, 30 µS full scale | |
| RANGE STUDIED: 20 mg/m ³ to 420 mg/m ³ (0.2 L to 6 L samples) | | CALIBRATION: Standard solutions of fluoride ion spiked onto sample media | |
| BIAS: -3.0% | | RANGE: 10 µg to 80 µg fluoride per sample [3] | |
| OVERALL PRECISION (\hat{S}_{r}): 0.070 [2] | | ESTIMATED LOD: 7 µg sulfuryl fluoride per sample [3] | |
| ACCURACY: ±16.7% | | PRECISION (\bar{S}): 0.052 (27 µg to 420 µg sulfuryl fluoride per sample) [2] | |

APPLICABILITY: The working range is 2.2 ppm to 17 ppm (9 mg/m³ to 75 mg/m³) for a 3 L air sample. This method is applicable to STEL measurements using a 1.5 L sample. The method has been used to sample for sulfuryl fluoride at dwelling fumigation sites [3,4].

INTERFERENCES: Other fluoride compounds may interfere.

OTHER METHODS: This method is based on the method of Bouyoucos, et al. [5]. NIOSH method S245 uses gas bag samples, gas chromatography-flame photometric detector (GC-FPD) [6].

REAGENTS:

1. Sodium hydroxide,* ACS reagent grade.
2. Sulfuric acid,* concentrated, ACS reagent grade.
3. Water, high-purity.
4. Desorbing/extracting solution and eluent: 40 mmol/L sodium hydroxide. Dissolve 3.2 g sodium hydroxide in 2 L of degassed high-purity water.
5. Suppressor regenerant, 12.5 mmol/L sulfuric acid. Add 0.70 mL concentrated sulfuric acid to 1 L of high-purity water.
6. Calibration stock solution, 1 mg/mL fluoride anion. Dissolve 0.2210 g sodium fluoride in high-purity water and dilute to the mark in a 100 mL volumetric flask.
7. Sulfuryl fluoride* calibration gas standard(s) (optional).

*See SPECIAL PRECAUTIONS.

EQUIPMENT:

1. Sampler: Activated coconut shell charcoal sampling tube; glass tube, 11 cm long, 10 mm OD, 7 mm ID, flame-sealed ends, containing two sections of activated (600 °C) coconut shell charcoal (front = 800 mg, back = 200 mg), separated by a 2 mm urethane foam plug. A silylated glass wool plug precedes the front section and a 3 mm urethane foam plug follows the back section. Pressure drop across the tube at 1 L/min airflow must be less than 3.4 kPa.
2. Personal sampling pump, 0.05 L/min to 0.10 L/min, with flexible polyethylene or PTFE tubing.
3. Refrigerant, water solution, sealed, refreezable, reusable.
4. Filter, membrane, 0.45 µm pore size, 13 mm, with Luer fitting.
5. Ion chromatograph, with a conductivity detector, chart recorder, integrator, and columns (page 6012-1).
6. Vials, glass, 20 mL, with plastic caps.
7. Vials, polyethylene, 20 mL, with plastic caps.
8. Micropipettes, with disposable plastic tips.
9. Volumetric flasks, 100 mL.
10. Pipet, 10 mL, graduated in 0.1 mL intervals.
11. Pipet, volumetric, 20 mL.
12. Syringes, 10 mL, plastic, with Luer tip.
13. Sonicator.
14. Analytical balance, to ±0.0001 g.

SPECIAL PRECAUTIONS: Sulfuryl fluoride is a restricted use pesticide owing to its inhalation toxicity. It is extremely hazardous as vapor or liquid. Inhalation of vapors may be fatal. Read and follow all label precautions [7]. Sulfuric acid and sodium hydroxide are corrosive to skin, eyes, and mucous membranes. Use proper protective clothing including gloves, safety glasses, and laboratory coat. Handle all hazardous chemicals in a fume hood.

SAMPLING:

1. Calibrate each personal sampling pump with a representative sampler in line.
2. Break the ends of the sampler immediately before sampling. Attach a sampler to personal sampling pump with flexible tubing.
3. Sample at an accurately known flow rate between 0.05 L/min and 0.1 L/min for a total sample volume of 1.3 L to 10 L.
4. Cap the samplers with plastic (not rubber) caps and pack securely for shipment at 0 °C.

SAMPLE PREPARATION:

5. Place the front and back sorbent sections of the sampler tube in separate 20 mL plastic vials. Discard the glass wool and foam plugs.

6. Add 20 mL 40 mmol/L sodium hydroxide eluent to each plastic vial. Cap. Sonicate for 60 min.
7. Transfer a 5 mL to 7 mL aliquot to a tare weighted 20 mL glass vial using a plastic syringe fitted with a 0.45 μm membrane filter.
8. Reweigh each glass vial and contents so that the net weight of the aliquot can be calculated.
9. Take each sample to complete dryness in an uncapped glass vial on a hot plate. Cool, then reconstitute to the original net weight with high-purity water.

CALIBRATION AND QUALITY CONTROL:

10. Calibrate daily with at least six working standards.

NOTE: Standards should be spiked onto charcoal tubes as follows to avoid high recoveries seen with liquid standards [4].

 - a. Add known amounts of calibration stock solution onto charcoal tubes (5.0 μg to 80 μg fluoride) and desorb in the same manner as field samples (steps 5, 6, 7, 8, and 9).
 - b. Analyze working standards together with samples and blanks (steps 12, 13, and 14).
 - c. Prepare a calibration graph of peak height vs. amount (μg) of fluoride per 20 mL of sample.
11. (Optional). Determine recovery (R) for each lot of tubes used for sampling in the concentration range of interest. Prepare four tubes at each of five levels plus three media blanks.
 - a. Collect a known amount of sulfonyl fluoride gas onto each charcoal tube (steps 1, 2, 3, 4, 5, 6, 7, 8, and 9).
 - b. Analyze samples in the same manner as field samples (steps 12, 13, and 14).
 - c. Prepare graph of recovery vs. μg sulfonyl fluoride.

MEASUREMENT:

12. Set ion chromatograph to conditions given on page 6012-1.
13. Refilter sample if necessary, then inject a sample aliquot into the ion chromatograph.
14. Measure peak height.

CALCULATIONS:

15. Determine mass (μg) of fluoride found on the front (W_f) and back (W_b) sections, and in the average media blank front (B_f) and back (B_b) sorbent section.

NOTE: If $W_f > W_b / 10$, report breakthrough and possible sample loss.
16. Calculate concentration, C , of sulfonyl fluoride in the actual air volume, V (L), applying the conversion factor 2.686 (molecular weight of sulfonyl fluoride divided by the atomic weight of 2 fluoride anions; the reaction is $\text{SO}_2\text{F}_2 + 4 \text{NaOH} \rightarrow 2 \text{NaF} + \text{Na}_2\text{SO}_4 + 2 \text{H}_2\text{O}$):

$$C = \frac{(W_f + W_b - B_f - B_b) \times 2.686}{V}, \mu\text{g/L or mg/m}^3.$$

EVALUATION OF METHOD:

This method was evaluated over the range 20 mg/m^3 to 420 mg/m^3 . Overall sampling and measurement precision, \hat{S}_{rr} , was 0.070 [2]. The average recovery of sulfonyl fluoride from charcoal was 99% when sampling atmospheres prepared in aluminized gas bags (Calibrated Instruments, Inc., Hawthorne, NY 10532). Recovery of fluoride from sampling media was 97% in the range 10 μg to 160 μg fluoride per sample. Sample stability during storage was evaluated at an air concentration of 417 mg/m^3 sulfonyl fluoride. Samples showed 101% recovery after 12 d of storage at 0 $^\circ\text{C}$ to 5 $^\circ\text{C}$ compared to one-day-old samples.

REFERENCES:

- [1] CDPR [2006]. Exposure assessment document for pesticide products containing sulfuryl fluoride. By Cochran R, DiPaolo D. Sacramento, CA: California Environmental Protection Agency, Department of Pesticide Regulation [www.cdpr.ca.gov/docs/emon/pubs/tac/tacpdfs/sulfluor/final_rcd_vol2.pdf]. Date accessed: January 2016.
- [2] NIOSH [1991]. Backup data report for sulfuryl fluoride. By Williamson GY. Cincinnati, OH: U.S. Department of Health and Human Services, Centers for Disease Control, National Institute for Occupational Safety and Health, Division of Physical Sciences and Engineering, Methods Research Support Branch. Unpublished.
- [3] NIOSH [1991]. Analytical report: sequence No. 7161-A. Cincinnati, OH: U.S. Department of Health and Human Services, Centers for Disease Control, National Institute for Occupational Safety and Health. Unpublished.
- [4] NIOSH [1993]. Analytical report: sequence No. 7691-D. Cincinnati, OH: U.S. Department of Health and Human Services, Centers for Disease Control and Prevention, National Institute for Occupational Safety and Health. Unpublished.
- [5] Bouyoucos SA, Melcher RG, Vaccaro JR [1983]. Collection and determination of sulfuryl fluoride in air by ion chromatography. *Am Ind Hyg Assoc J* 44(1):57-61.
- [6] NIOSH [1980]. Sulfuryl fluoride: Method S245. In: Taylor DG, ed. NIOSH manual of analytical methods. 2nd ed. Vol. 6. Cincinnati, OH: U.S. Department of Health and Human Services, Centers for Disease Control, National Institute for Occupational Safety and Health, DHHS (NIOSH) Publication No. 80-125, available as accession No. PB82-157728 from NTIS [www.ntis.gov].
- [7] NIOSH/OSHA [1981]. Occupational health guideline for sulfuryl fluoride. In: NIOSH/OSHA Occupational health guidelines for chemical hazards. Cincinnati, OH: U.S. Department of Health and Human Services, Centers for Disease Control, National Institute for Occupational Safety and Health, DHHS (NIOSH) Publication No. 81-123 [www.cdc.gov/niosh/docs/81-123/].

METHOD WRITTEN BY:

George Y. Williamson, MRSB, DPSE.

DISCLAIMER: Mention of any company or product does not constitute endorsement by NIOSH. In addition, citations to websites external to NIOSH do not constitute NIOSH endorsement of the sponsoring organizations or their programs or products. Furthermore, NIOSH is not responsible for the content of these websites. All web addresses referenced in this document were accessible as of the publication date.



AMMONIA by IC

6016

NH₃

MW: 17.03

CAS: 7664-41-7

RTECS: BO0875000

METHOD: 6016, Issue 2

EVALUATION: FULL

Issue 1: 15 May 1996

Issue 2: 3 March 2016

OSHA: 50 ppm
NIOSH: 25 ppm; STEL 35 ppm

PROPERTIES: gas; MP -77.7 °C; BP -33.4 °C; VP 888 kPa (8.76 atm) @ 21.1 °C; vapor density 0.6 (air = 1); explosive range 16 to 25% v/v in air

SYNONYMS: none

| SAMPLING | | MEASUREMENT | |
|--|--|--|---|
| SAMPLER: | SOLID SORBENT TUBE (sulfuric acid-treated silica gel); a 0.8-µm MCE prefilter may be used to remove particulate interferences. | TECHNIQUE: | ION CHROMATOGRAPHY, CONDUCTIVITY DETECTION |
| FLOW RATE: | 0.1 - 0.5 L/min | ANALYTE: | ammonium ion (NH ₄ ⁺) |
| VOL-MIN: | 0.1 L @ 50 ppm | EXTRACTION ION: | 10 mL deionized water |
| -MAX: | 96 L @ 50 ppm {1} | INJECTION VOLUME: | 50 µL |
| SHIPMENT: | routine | ELUENT: | 48 mM HCl/4 mM DAP-HCl/4 mM L-histidine-HCl; 1 mL/min alternate: 12 mM HCl/0.25 mM DAP-HCl/0.25 mM L-histidine-HCl; 1 mL/min |
| SAMPLE STABILITY: | at least 35 days @ 5 °C [2] | COLUMNS: | cation separator; cation guard; cation micromembrane suppressor |
| BLANKS: | 2 to 10 field blanks per set | CONDUCTIVITY SETTING: | 30 µS full scale |
| ACCURACY | | CALIBRATION: | standard solutions of NH ₄ ⁺ in deionized water |
| RANGE STUDIED: | 17 to 68 mg/m ³ [1] (30-L samples) | RANGE: | 8 to 100 µg/sample [3] |
| BIAS: | -2.4% | ESTIMATED LOD: | 2 µg/sample [3] |
| OVERALL PRECISION ($\hat{S}_{r,T}$): | 0.071 [1] | PRECISION (\bar{S}_r): | 0.038 [2] |
| ACCURACY: | ± 14.5% | | |

APPLICABILITY: The working range is 24 to 98 ppm (17 to 68 mg/m³) for a 30-L sample [1]. This method is applicable to STEL measurements when sampled at 0.2 L/min.

INTERFERENCES: Ethanolamines (monoethanolamine, isopropanolamine, and propanolamine) have retention times similar to NH₄⁺. The use of the alternate (weak) eluent will aid in separating these peaks.

OTHER METHODS: This method combines the sampling procedure of methods S347 [4] and 6015 [5] with an ion chromatographic analytical procedure similar to Method 6701 [6] and OSHA Method ID-188 [3].

REAGENTS:

1. Water, deionized, filtered.
2. Sulfuric acid (H_2SO_4), 0.01 N:* Add 0.28 mL conc. H_2SO_4 to 500 mL deionized water in 1-L volumetric flask. Dilute to 1 L with deionized water.
3. Hydrochloric acid (HCl), 1 N:* Add 82.5 mL conc. HCl to 500 mL deionized water in 1-L volumetric flask. Dilute to 1 L with deionized water.
4. 2,3-diaminopropionic acid monohydrochloride (DAP-HCl)
5. L-histidine monohydrochloride monohydrate (L-histidine-HCl)
6. Eluent (48 mM HCl/4 mM DAP-HCl/4 mM L-histidine-HCl): Place 0.560 g DAP-HCl and 0.840 g L-histidine-HCl in a 1-L volumetric flask. Add 48 mL of 1 N HCl, dilute to volume with deionized water. Prepare monthly.
7. Alternate eluent (12 mM HCl/0.25 mM DAP-HCl/0.25 mM L-histidine-HCl): Dilute 252 mL strong eluent and 36 mL 1 N HCl to 4 L with deionized water. Prepare fresh for each use.
8. Tetramethylammonium hydroxide (TMAOH), 25% in water.
9. Regenerant solution: Dilute 57.4 mL of 25% TMAOH to 4 L with deionized water.
10. Ammonia stock solution, 1000 $\mu\text{g}/\text{mL}$ as NH_3 (1059 $\mu\text{g}/\text{mL}$ as NH_4^+): Dissolve 3.1409 g ammonium chloride in deionized water. Dilute to 1 L.

*See SPECIAL PRECAUTIONS.

EQUIPMENT:

1. Sampler:
 - a. Prefilter: 37-mm mixed cellulose ester membrane filter, 0.8- μm pore size, stainless steel or porous plastic screen in two piece cassette filter holder.
 - b. Sulfuric acid-treated silica gel, glass tube, unsealed and fire-polished, 6.0 cm long, 6-mm OD, 4-mm ID, containing two sections of 20/40 mesh sulfuric acid-treated silica gel (200 mg front/100 mg back) separated and held in place with plugs of silylated glass wool, and capped with plastic caps.
2. Personal sampling pump, 0.1 to 0.5 L/min, with flexible tubing.
3. Ion Chromatograph with conductivity detector, cation column and guard, and cation micromembrane suppressor (see Evaluation).
4. Syringes, 10-mL, polyethylene, Luer tip.
5. Centrifuge tubes, 15-mL, graduated, plastic with screw caps.
6. Volumetric flasks, 10-, 50-, 100-mL, and 1-L.
7. Syringe filters, 13-mm, 0.8- μm , membrane filter.
8. Micropipets, disposable tips.
9. Analytical balance (sensitivity to 0.01 mg).

SPECIAL PRECAUTIONS: Concentrated acids are corrosive to skin. Handle acid in a fume hood. Wear protective gloves.

SAMPLING:

1. Calibrate each personal sampling pump with a representative sampler in line.
2. Sample at an accurately known flow rate between 0.1 and 0.5 L/min for a total sample size of 0.1 to 96 L.
3. Cap the sampling tubes with plastic (not rubber) caps immediately after sampling.
4. Pack securely for shipment.

SAMPLE PREPARATION:

5. Remove caps from sampling tubes. Transfer the front and back sections of sulfuric acid-treated silica gel to separate 15-mL graduated centrifuge tubes.
NOTE: Firm tapping of the tube may be necessary to effect complete transfer of the sulfuric acid-treated silica gel.
6. Add 10 mL of deionized water to each centrifuge tube. Cap and shake vigorously. Allow to stand 45 minutes with occasional shaking. (Desorption is complete in 45 minutes.)
NOTE: Analyses should be completed within one day after the ammonia is desorbed.
7. Transfer samples to 10-mL syringes fitted with inline syringe filters for manual injection or transfer to autosampler vials.

CALIBRATION AND QUALITY CONTROL:

8. Calibrate daily with at least six working standards over the range of 1 to 110 µg NH₃ per sample (about 0.11 to 12 µg/mL NH₄⁺).
9. Add known aliquots of ammonia stock solution to 0.01 N H₂SO₄ in 10-mL volumetric flasks.
NOTE: Prepare standards just before use.
10. Analyze working standards together with samples and blanks (steps 9 through 11).
11. Prepare calibration graph (peak height vs. µg NH₃).

MEASUREMENT:

12. Set ion chromatograph to conditions given on page 6016-1, according to manufacturer's instructions.
13. Inject 50-µL sample aliquot manually or with autosampler. For manual operation, inject 2 to 3 mL of sample from filter/syringe to ensure complete rinse of sample loop.
14. Measure peak height.
NOTE: If peak height exceeds linear calibration range, dilute with 0.01 N H₂SO₄, reanalyze and apply the appropriate dilution factor in calculations.

CALCULATIONS:

15. Determine the mass, µg, of ammonia found in the sample front (*W_f*) and back (*W_b*) sorbent sections, and in the average media blank front (*B_f*) and back (*B_b*) sorbent sections.
16. Calculate concentration, *C*, of NH₃ in the air volume sampled, *V* (L):

$$C = \frac{W_f + W_b - B_f - B_b}{V}, \text{ mg/m}^3$$

EVALUATION OF METHOD:

This method combines the sampling procedure of NIOSH Methods S347 [4] and 6015 [5] with the ion chromatographic analytical procedure of NIOSH Method 6701 [6] and OSHA Method ID-188 [3]. This method used HPIC-CS3 cation separator, HPIC-CG3 cation guard and CMMS-1 cation micromembrane suppressor. This method will serve as an alternate analytical procedure to the automated spectrophotometric procedure of NIOSH Method 6015 [5]. Although the methods from which this method is derived are fully evaluated methods, the combination of the sulfuric acid-treated silica gel sampler and IC analysis has not received a full evaluation, as such. During the development of the passive monitor method for ammonia (6701), sulfuric acid-treated silica gel tubes were used as one of the reference methods [6]. The silica gel samples with IC analysis showed good agreement with the other reference methods, bubbler collection with colorimetric analysis using Nessler's Reagent, and bubbler collection with IC analysis.

A storage stability study compared the sulfuric acid-treated silica gel tube and sulfuric acid-treated carbon beads used in OSHA Method ID-188 [3]. When stored at room temperature for five days and then

refrigerated for 21 days, silica gel samples had a mean recovery of $102 \pm 3.8\%$ ($n = 8$), while carbon beads had a mean recovery of $95 \pm 1.6\%$ ($n = 8$). The samples stored on carbon beads for 35 days showed significantly lower (although still acceptable) recovery compared to samples stored for 14 days: $103 \pm 3.8\%$ for silica gel ($n = 12$), and $108 \pm 7.0\%$ for carbon beads ($n = 12$) [2].

REFERENCES:

- [1] NIOSH [1977]. Ammonia: Backup data report No. S347. Ten NIOSH analytical methods, set 6. SRI International Contract No. 210-76-0123. (NTIS PB-288629)
- [2] Copenhafer RB, Dearden PA [1995]. User check of method 6015 for ammonia. Sequence 8321-J, K, L, M. Salt Lake City, UT: DataChem Laboratories. Unpublished.
- [3] OSHA [1991]. Ammonia in workplace atmospheres - solid sorbent: Method ID-188. In: OSHA analytical methods manual, 2nd ed., Part 2, Inorganic substances. Salt Lake City, UT: U.S. Department of Labor, Occupational Safety and Health Administration.
- [4] NIOSH [1979]. Ammonia: Method S347. In: Taylor DG, ed. NIOSH manual of analytical methods, 2nd ed., volume 5. Cincinnati, OH: U.S. Department of Health, Education and Welfare, Center for Disease Control, National Institute for Occupational Safety and Health, DHEW (NIOSH) Publication No. 79-141.
- [5] NIOSH [1994]. Ammonia: Method 6015. In: Eller PM, Cassinelli ME, eds. NIOSH manual of analytical methods, 4th ed. Cincinnati, OH: U.S. Department of Health and Human Services, Centers for Disease Control and Prevention, National Institute for Occupational Safety and Health, DHHS(NIOSH) Publication No. 94-113 [www.cdc.gov/niosh/nmam].
- [6] NIOSH [1984]. Ammonia: Method 6701. In: Eller PM, Cassinelli ME, eds. NIOSH manual of analytical methods, 3rd ed. Cincinnati, OH: U.S. Department of Health and Human Services, Centers for Disease Control, National Institute for Occupational Safety and Health, DHHS (NIOSH) Publication No. 84-100.

METHOD WRITTEN BY:

Mary Ellen Cassinelli, NIOSH

Disclaimer: Mention of any company or product does not constitute endorsement by NIOSH. In addition, citations to websites external to NIOSH do not constitute NIOSH endorsement of the sponsoring organizations or their programs or products. Furthermore, NIOSH is not responsible for the content of these websites. All web addresses referenced in this document were accessible as of the publication date.



CARBON MONOXIDE

6604

CO

MW: 28.00

CAS: 630-08-0

RTECS: FG3500000

METHOD: 6604, Issue 2

EVALUATION: FULL

Issue 1: 15 May 1996

Issue 2: 16 March 2016

OSHA: 50 ppm
NIOSH: 35 ppm; C 200 ppm

PROPERTIES: colorless, odorless gas; BP -192 °C MP -207 °C; vapor density (air=1) 0.97; flammable (explosive) limits in air: 12.5 to 74.2%

SYNONYMS: monoxide; carbon oxide; carbonic oxide; flue gas

| SAMPLING | | MEASUREMENT | |
|---|--|--|---|
| SAMPLER: | PORTABLE ELECTROCHEMICAL DIRECT-READING CO MONITOR | TECHNIQUE: | ELECTROCHEMICAL SENSOR |
| FLOW RATE: | instrument dependent | ANALYTE: | carbon monoxide (CO) |
| VOL-MIN: | 10 L | CALIBRATION | |
| -MAX: | none | -ZERO: | CO-free air |
| SHIPMENT: | routine shipment of instrumentation | -SPAN: | standard cylinders of span gas in the desired range |
| SAMPLE STABILITY: | at least 7 days @ 25 °C [1] (aluminized air bags) | RANGE: | 0 to 200 ppm |
| BLANKS: | fresh air or compressed CO-free air from cylinder | ESTIMATED LOD: | 1 ppm |
| ACCURACY | | PRECISION (\bar{S}_r): | 0.035 @ 20 ppm 0.012 @ 50 ppm 0.008 @ 100 ppm [2] |
| RANGE STUDIED: | 0 to 200 ppm | | |
| BIAS: | - 1.7% [2] | | |
| OVERALL PRECISION (\hat{S}_{rT}): | 0.022 [2] | | |
| ACCURACY: | ± 6.0% | | |

APPLICABILITY: Portable, direct-reading carbon monoxide monitors are applicable to any work environment for personal or area monitoring.

INTERFERENCES: Several gaseous pollutants (e.g., NO₂, SO₂) may cause an interference at levels over 5 ppm. If these or other pollutants are known or suspected to be present, use a monitor with a chemical interference scrubber over the sensor. Unknown pollutants may require further experimentation to determine their effect on the sensor. As tested, SO₂ (5 ppm), CO₂ (5000 ppm), methylene chloride (500 ppm), diesel fuel (6 µL/L, about 0.3 ppm benzene), and gasoline vapor (1 µL/L, about 1 ppm benzene) had no impact on most monitor readings [2]. Some monitors are equipped with a chemical interference scrubber while others offer this as an option.

OTHER METHODS: OSHA methods ID 209 (CO by direct-reading monitor) [3] and ID 210 (CO by gas bag sampling) [4] are similar techniques.

REAGENTS:

1. CO* calibration gas, 20 to 50 ppm, compressed gas cylinder, appropriate pressure regulator, and other items as recommended by manufacturer for field check of monitor response.

*See SPECIAL PRECAUTIONS.

EQUIPMENT:

1. Electrochemical carbon monoxide monitoring instrument designed and intended for industrial use (not a residential use alarm/monitor); fixed-location mountable for area alarm/monitoring, compact portable for person alarm/monitoring, or both; with integral concentration display.
2. Personal sampling pump, 0.250 L/min, with inlet and outlet, used for bag filling and sample analysis (e.g., when off-site analysis is needed).
3. Air bags, aluminized, 2-L, or other appropriate sizes (optional).
4. Replacement batteries or battery recharger, as appropriate for monitor.

SPECIAL PRECAUTIONS: Carbon monoxide is a highly flammable, dangerous fire and explosive risk, and is toxic by inhalation. Shipments of compressed calibration gases must comply with 49 CFR 1992 regulations.

SAMPLING:

1. Zero monitor with CO-free air at the same temperature and relative humidity as the work environment, if possible.
NOTE 1: Monitors are more sensitive to temperature variations than to humidity variations. Most monitors have temperature compensating circuitry.
NOTE 2: If applicable, bag samples may be collected in aluminized bags (2-L or larger) and analyzed later by placing the calibration cap over the sensor and pumping the sample across the sensor at a nominal rate of 0.250 L/min with a personal sampling pump.
2. For personal monitoring, locate the monitor as near the worker's breathing zone as possible.
3. For area monitoring, locate monitor in an area with good air circulation about 60 to 70 inches above the floor.
NOTE: Make sure the sensor is not obstructed in either application.

CALIBRATION AND QUALITY CONTROL:

4. Calibrate with a standard calibration mixture of CO in air (e.g., in gas bag samples of known concentrations) from a pressurized cylinder at the CO level recommended by the monitor manufacturer (normally, 20 to 50 ppm CO). The monitor should be calibrated at the temperature and relative humidity as near as possible to that of the work environment in which it will be used.
5. Check the calibration daily and recalibrate whenever the monitor reading varies from the span gas by 5% or more, or as the manufacturer recommends.

MEASUREMENT:

6. Read concentration directly (in ppm) from the monitor display.
Some monitors (data logger models) will maintain a continuous record of the data as it is accumulated and will calculate the average, TWA, peak, etc. concentrations. These data may be read from the display at any time. Some monitors will also store this information for downloading to a computer or printer at the end of the monitoring period. Other monitors only display the current reading, requiring

the operator to manually record the data. All monitor models are equipped with alarms that will warn the user (audibly, visually or both) whenever the concentration of CO exceeds the preset level of the alarm. Many are equipped with two-level alarms [5].

EVALUATION OF METHOD:

The performance of six direct-reading carbon monoxide monitors was evaluated over a period of 12 months at CO concentrations up to 200 ppm and a range of ambient temperatures and relative humidity. Most of the tests were conducted at or near the PEL. For mean recovery studies, six different monitors were used and readings were taken approximately 1 h apart. Recovery at 20 ppm was 105% ($n = 42$); at 50 ppm, 99.6% ($n = 36$); and at 100 ppm, 99.9% ($n = 30$). Thus, the overall mean bias was calculated at -1.7%. The precision (\bar{S}_r) at 20 ppm was 0.035 (35 readings from 5 monitors over a 7-h period). At 50 ppm, \bar{S}_r was 0.012 (30 readings from 5 monitors over a 6-h period), and at 100 ppm, \bar{S}_r was 0.008 (36 readings from 6 monitors over a 6-h period). Tests also were conducted to determine response time, zero and span drift, alarm decibel level, battery life, life of the sensors, as well as the effects of selected interferences (gases, vapors, and RF) and the effects of handling and transporting to remote sites. See [6] for preliminary work on carbon monoxide monitoring.

REFERENCES:

- [1] Stanford Research Institute [1977]. Backup Data Report: Method S340. Menlo Park, CA: Stanford Research Institute. NIOSH contract no. 210-76-0123.
- [2] Woodfin WJ, Wuebkenberg ML [1985]. Evaluation of portable direct-reading carbon monoxide monitors. Unpublished.
- [3] OSHA [1993]. Method ID 209, Carbon monoxide in workplace atmospheres (Direct-reading monitor); In: Sampling and analytical methods. Salt Lake City, UT: U.S. Department of Labor, Occupational Safety and Health Association.
- [4] OSHA [1991]. Method ID 210, Carbon monoxide in workplace atmospheres (Gas bag sampling); In: Sampling and analytical methods. Salt Lake City, UT: U.S. Department of Labor, Occupational Safety and Health Association.
- [5] Ashley K [1994]. Electroanalytical applications in occupational and environmental health. *Electroanalysis* 6:805-820.
- [6] Wuebkenberg ML [1983]. Monitoring methodology for gaseous hazards – Passive monitors and portable instruments. *Scand J Work Environ Health* 9:223-229.

METHOD REVISED BY:

W. James Woodfin, NIOSH

Disclaimer: Mention of any company or product does not constitute endorsement by NIOSH. In addition, citations to websites external to NIOSH do not constitute NIOSH endorsement of the sponsoring organizations or their programs or products. Furthermore, NIOSH is not responsible for the content of these websites. All web addresses referenced in this document were accessible as of the publication date.



LEAD by Flame AAS

7082

Pb MW: 207.19 (Pb) CAS: 7439-92-1 (Pb) RTECS: OF7525000 (Pb)
 MW: 223.19 (PbO) CAS: 1317-36-8 (PbO) RTECS: OG1750000 (PbO)

METHOD: 7082, Issue 3

EVALUATION: FULL

Issue 1: 15 February 1984

Issue 3: 12 July 2017

OSHA: 0.050mg/m³
NIOSH: 0.050 mg/m³
OTHER OELs: [1-3]

PROPERTIES: soft metal; d 11.3 g/cm³; MP 327.5 °C
 valences +2, +4 in salts

SYNONYMS: elemental lead and lead compounds, except alkyl lead

| SAMPLING | | MEASUREMENT | |
|--|--|--|---|
| SAMPLER: | FILTER (0.8- μ m cellulose ester membrane) or INTERNAL CAPSULE, cellulose acetate dome with inlet opening attached to filter | TECHNIQUE: | ATOMIC ABSORPTION SPECTROPHOTOMETER, FLAME |
| FLOW RATE: | 1 to 4 L/min | ANALYTE: | lead |
| VOL-MIN: | 200 L @ 0.05 mg/m ³ | ASHING: | conc. HNO ₃ , 6 mL + 30% H ₂ O ₂ , 1 mL; 140°C |
| -MAX: | 1500 L | FINAL SOLUTION: | 10% HNO ₃ , 10 mL |
| SHIPMENT: | routine | FLAME: | air-acetylene, oxidizing |
| SAMPLE STABILITY: | stable at least 7 weeks [4] | WAVELENGTH: | 283.3 nm |
| BLANKS: | 2 to 10 field blanks per set | BACKGROUND CORRECTION: | D ₂ or H ₂ lamp, or Zeeman |
| ACCURACY | | CALIBRATION: | Pb ²⁺ in 10% HNO ₃ |
| RANGE STUDIED: | 0.13 to 1.7 mg/m ³ [8] | RANGE: | 10 to 200 μ g/sample [6,7] |
| BIAS: | -3.1% | ESTIMATED LOD: | 2.6 μ g/sample [8] |
| OVERALL PRECISION ($\hat{S}_{r,T}$): | 0.07 [5,6] | PRECISION (\bar{S}_r): | 0.03 [5] |
| ACCURACY: | \pm 17.6% | | |

APPLICABILITY: The working range is 0.05 to >1 mg/m³ for a 200-L air sample. The method is applicable to elemental lead, including Pb fume, and all other aerosols containing lead. This is an elemental analysis, not compound specific. Aliquots of the samples can be analyzed separately for additional elements. This method has been updated to include internal capsule samplers.

INTERFERENCES: Use D₂ or H₂ continuum or Zeeman background correction to control flame or molecular absorption. High concentrations of calcium, sulfate, carbonate, phosphate, iodide, fluoride, or acetate can be corrected for.

OTHER METHODS: This method combines and replaces P&CAM 173 [7] and S341 [8] for lead. NIOSH Methods 7300 (ICP-AES), 7701 (ASV) and 7105 (GFAAS) are alternative analytical methods. NIOSH Method 7505 is specific for lead sulfide. A consensus standard method, ASTM D6785, has been published [9].

REAGENTS:

1. Nitric acid, conc., trace metal grade*
2. Nitric acid, 10% (v/v). Add 100 mL conc. HNO₃ to 500 mL water; dilute to 1 L
3. Hydrogen peroxide, 30% H₂O₂ (w/w), reagent grade.*
4. Calibration stock solution, 1000 µg/mL Pb. Commercial standard or dissolve 1.00 g Pb metal in minimum volume of (1+1) HCl and dilute to 1 L with 1% (v/v) HCl. Store in a polyethylene bottle. Stable > one year.
5. Air, compressed, filtered.
6. Acetylene
7. Distilled or deionized water

*See SPECIAL PRECAUTIONS.

EQUIPMENT:

1. Sampler: Cellulose ester filter or cellulose acetate internal capsule attached to mixed cellulose ester membrane filter, 0.8-µm pore size, 37-mm diameter, in 2-piece cassette filter holder.
2. Personal sampling pump, 1 to 4 L/min, with flexible connecting tubing.
3. Atomic absorption spectrophotometer with an air-acetylene burner head and background correction.
4. Lead hollow cathode lamp or electrode dischargeless lamp.
5. Regulators, two-stage, for air and acetylene.
6. Beakers, Phillips, 125-mL, or Griffin, 50-mL with watch glass covers.**
7. Volumetric flasks, 10- and 100-mL.**
8. Assorted volumetric pipets, as needed.**
9. Hotplate, surface temperature 140 °C.
10. Bottles, polyethylene, 100-mL.

** Clean all glassware with conc. nitric acid and rinse thoroughly with distilled or deionized water before use.

SPECIAL PRECAUTIONS: Wear appropriate personal protection during sampling activities and analysis. It is essential that suitable gloves, eye protection, laboratory coat, etc., be used when working with the chemicals. Concentrated nitric acid is an irritant and may burn skin. Perform all acid digestions in a fume hood. Hydrogen peroxide is a strong oxidizing agent, a strong irritant, and corrosive to the skin. Wear gloves and eye protection.

SAMPLING:

1. Calibrate each personal sampling pump with a representative sampler in line.
NOTE: See NMAM guidance chapters for discussion on sampling.
2. Sample at an accurately known flow rate between 1 and 4 L/min (± 5%) for up to 8 h for a total sample size of 200 to 1500 L for TWA measurements. Do not exceed a filter loading of approximately 5 mg total dust.
NOTE: Filter overloading can be assessed by periodic visual checks. See NMAM guidance chapters for additional discussion on filter capacity.

SAMPLE PREPARATION:

3. Open the cassette filter holders and transfer the samples and blanks to clean beakers.
NOTE: If internal capsules are not used, wipe the internal cassette surfaces with a polyvinyl alcohol wipe or cellulosic wipe wetted with deionized water, and add the wipe to the digestion vessel (to transfer non-filter aerosol deposits into the digestion vessels) [10].

NOTE: The following sample preparation gave quantitative recovery (see EVALUATION OF METHOD) [8]. Steps 4 through 9 of Method 7300 or other quantitative ashing techniques may be substituted, especially if several metals are to be determined on a single filter.

NOTE: The Appendix gives a microwave digestion procedure, which may be necessary for complete recovery of lead from some matrices, especially epoxy-based paint.

4. Add 3 mL conc. HNO₃, and 1 mL 30% H₂O₂ and cover with a watch glass. Start reagent blanks at this step.

NOTE: If PbO₂ is not present in the sample, the 30% H₂O₂ need not be added [6,8].

5. Heat on 140 °C hotplate until volume is reduced to about 0.5 mL.
6. Repeat two more times using 2 mL conc. HNO₃ and 1 mL 30% H₂O₂ each time.
7. Heat on 140 °C hotplate until ca. 0.5 mL liquid remains.
8. When sample is dry, rinse the watch glass and walls of the beaker with 3 to 5 mL 10% HNO₃. Allow the solution to evaporate to dryness.
9. Cool each beaker and dissolve the residues in 1 mL conc. HNO₃.
10. Transfer the solution quantitatively to a 10-mL volumetric flask and dilute to volume with distilled water.

NOTE: If the concentration (M) of any of the following is expected to exceed the lead concentration (M) by 10-fold or more, add 1 mL 1 M Na₂EDTA to each flask before dilution to volume: CO₃²⁻, PO₄³⁻, I⁻, F⁻, CH₃COO⁻ [8]. If Ca²⁺ or SO₄²⁻ are present in 10-fold or greater excess, make all standards and samples with 1% (w/w) La²⁺ [7].

CALIBRATION AND QUALITY CONTROL:

11. Prepare a series of working standards covering the range 0.25 to 20 µg/mL Pb (2.5 to 200 µg Pb per sample).
 - a. Add aliquots of calibration stock solution to 100-mL volumetric flasks. Dilute to volume with 10% HNO₃. Store the working standards in polyethylene bottles and prepare fresh weekly.
 - b. Analyze the working standards together with the blanks and samples (steps 14 and 15).
 - c. Prepare a calibration graph of absorbance vs. solution concentration (µg/mL)
12. Aspirate a standard for every 10 samples to check for instrument drift.
13. Check recoveries with at least one spiked media blank per 10 samples. Use method of standard additions occasionally to check for interferences.

MEASUREMENT:

14. Set spectrophotometer as specified by the manufacturer and to conditions on page 7082-1.

NOTE: An alternate wavelength is 217.0 nm [11]. Analyses at 217.0 nm have slightly greater sensitivity, but poorer signal-to-noise ratio compared to 283.3 nm. Also, non-atomic absorption is significantly greater at 217.0 nm, making the use of D₂ or H₂ continuum, or Zeeman background correction mandatory at that wavelength.
15. Aspirate standards, samples, and blanks. Record absorbance readings.

NOTE: If the absorbance values for the samples are above the linear range of the standards, dilute with 10% HNO₃, reanalyze, and apply the appropriate dilution factor in the calculations.

CALCULATIONS:

16. Using the measured absorbances, calculate the corresponding concentrations (µg/mL) of lead in the sample, C_s, and average media blank, C_b, from the calibration graph.
17. Using the solution volumes (mL) of the sample, V_s, and media blanks, V_b, calculate the concentration, C (mg/m³), of lead in the air volume sampled, V (L):

$$C = \frac{C_s V_s - C_b V_b}{V}, \frac{mg}{m^3}$$

NOTE: µg/mL ≈ mg/m³.

EVALUATION OF METHOD:

The predecessor to NIOSH 7082, Method S341 [8], was issued on October 24, 1975, and validated over the range 0.13 to 0.4 mg/m³ for a 180-L air sample, using generated atmospheres of lead nitrate [5]. Recovery in the range 18 to 72 µg Pb per sample was 98%, and collection efficiency of 0.8-µm mixed cellulose ester filters (Millipore Type AA) was 100% for the aerosols at the detection limit of 0.013 mg/m³. Subsequent studies on analytical recovery of 200 µg Pb per sample gave the following results [6,8]:

| Species | Digestion method | Analytical recovery, % |
|------------------|--|------------------------|
| Pb metal | HNO ₃ only | 92.4 ± 4 |
| Pb metal | HNO ₃ + H ₂ O ₂ | 103 ± 3 |
| PbO | HNO ₃ only | 93 ± 4 |
| PbS | HNO ₃ only | 93 ± 5 |
| PbO ₂ | HNO ₃ only | 82 ± 3 |
| PbO ₂ | HNO ₃ + H ₂ O ₂ | 100 ± 1 |
| Pb in paint* | HNO ₃ only | 95 ± 6 |
| Pb in paint* | HNO ₃ + H ₂ O ₂ | 95 ± 6 |

*Standard Reference Material #1579, U.S. National Institute of Standards and Technology

Additional collection efficiency studies were also done using Gelman GN-4 metrical cellulose acetate membrane filters for the collection of Pb fume, which had geometric mean diameter of 0.1 µm [5]. Mean collection efficiency for 24 sampling runs at flow rates between 0.15 and 4.0 L/min was >97 ± 2%. Overall precision, S_{rT} , was 0.072 for lead nitrate aerosol [5,8] and 0.068 for Pb fume [6,8].

Evaluation information on internal capsule samplers may be found in NIOSH 7306 [12].

REFERENCES:

- [1] ACGIH [2016]. TLVs[®] and BEIs[®] based on the documentation of the Threshold Limit Values for chemical substances and physical agents and Biological Exposure Indices. Cincinnati, Ohio: American Conference of Governmental Industrial Hygienists.
- [2] Permanent Senate Commission for the Investigation of Health Hazards of Chemical Compounds in the Work Area [2016]. List of MAK and BAT values 2016; Maximum Concentrations and Biological Tolerance Values at the Workplace. Weinheim, Germany: Wiley-VCH Verlag GmbH & Co., <http://dx.doi.org/10.1002/9783527805983>.
- [3] Institute for Occupational Safety and Health of the German Social Accident Insurance (IFA) [no date]. GESTIS international limit values, <http://limitvalue.ifa.dguv.de/>. Date accessed: July 12, 2017.
- [4] Marks GE, Knutsen EO [1975]. Complete testing of the NIOSH method for the determination of trace metals by atomic absorption spectrophotometry. Chicago, IL: IIT Research Institute, NIOSH contract no. CDC-99-74-48.
- [5] Taylor DG, Kupel RE, Bryant JM. [1977]. Documentation of the NIOSH validation tests. Cincinnati, OH: U.S. Department of Health, Education, and Welfare, Center for Disease Control, National Institute for Occupational Safety and Health, DHEW (NIOSH) Publication No. 77-185. Available from www.ntis.gov as accession no. PB274248
- [6] Gutknecht WF, Ranade MH, Grohse PM, Damle A, O'Neal D [1981]. Heavy metal aerosols: Collection and dissolution efficiencies. Research Triangle Park, NC: Research Triangle Institute, Contract 210-79-0058, Available from www.ntis.gov as accession no. PB83-106740.

-
- [7] NIOSH [1979]. Method P&CAM 173. In: Taylor DG, ed. NIOSH manual of analytical methods. 2nd ed. Cincinnati, OH: U.S. Department of Health, Education and Welfare, Center for Disease Control, National Institute for Occupational Safety and Health, DHEW (NIOSH) Publication No. 77-157-A.
- [8] NIOSH [1982]. Method S341. In: Taylor DG, ed. NIOSH manual of analytical methods. 2nd ed. Cincinnati, OH: U.S. Department of Health and Human Services, Center for Disease Control, National Institute for Occupational Safety and Health, DHEW (NIOSH) Publication No. 82-100.
- [9] ASTM International [2013]. ASTM D6785, Standard test method for determination of lead in workplace air using flame or graphite furnace atomic absorption spectrometry. West Conshohocken, PA: ASTM International.
- [10] Ashley K, Harper M [2013]. Closed-face filter cassette (CFC) sampling - Guidance of procedures for inclusion of material adhering to internal sampler surfaces. *J Occup Environ Hyg* 10:D29-D33.
- [11] Perkin-Elmer Corporation [1976]. Analytical methods for atomic absorption spectrophotometry. Norwalk, CT: Perkin-Elmer Corporation.
- [12] NIOSH [2015]. Method 7306. In: Ashley K, O'Connor PF, eds. NIOSH manual of analytical methods. 5th ed. Cincinnati, OH: U.S. Department of Health and Human Services, Centers for Disease Control and Prevention, National Institute for Occupational Safety and Health, DHHS (NIOSH) Publication No. 14-151.
- [13] DataChem Laboratories [no date]. In-house procedure for microwave sample digestion. Salt Lake City, UT: DataChem Laboratories. Unpublished.
- [14] EPA [1986]. SW-846: Test methods for evaluating solid waste, Physical and chemical methods, 3rd ed. Washington, DC: U.S. Environmental Protection Agency.
- [15] Kingston HM, Jassie LB, eds. [1988]. Safety guidelines for microwave systems in the analytical laboratory. In: Introduction to microwave acid decomposition: Theory and practice. Washington, DC: American Chemical Society.
- [16] ASTM International [2011]. ASTM D1193, Standard specification for reagent water. West Conshohocken, PA: ASTM International.
- [17] Kingston HM, Jassie LB, eds. [1988]. Introduction to microwave acid decomposition: Theory and practice. Washington, DC: American Chemical Society.
- [18] Kingston HM [1988]. Quarterly Report, EPA IAG #DW1-393254-01-1.
- [19] Binstock DA, Yeager WM, Grohse PM, Gaskill A [1989]. Validation of a method for determining elements in solid waste by microwave digestion, Draft technical report for RTI Project number 321U-3579-24. Research Triangle Park, NC: Research Triangle Institute.

METHOD REVISED BY:

Mark Millson, R. DeLon Hull, PhD, and Ronnee N. Andrews, PhD, NIOSH. S341 originally validated under NIOSH contract CDC-94-74-45; additional studies under NIOSH contract 210-79-0058.

James B. Perkins, David L. Wheeler, and Keith Nicholson, Ph.D., DataChem Laboratories, Salt Lake City, UT, prepared the microwave digestion procedure described in the Appendix.

Disclaimer: Mention of any company or product does not constitute endorsement by NIOSH. In addition, citations to websites external to NIOSH do not constitute NIOSH endorsement of the sponsoring organizations or their programs or products. Furthermore, NIOSH is not responsible for the content of these websites. All web addresses referenced in this document were accessible as of the publication date.

APPENDIX: MICROWAVE DIGESTION FOR LEAD IN PAINT CHIPS (AND OTHER MATRICES)

This procedure is an alternative to the procedure presented in the Sample Preparation section of this method. It provides a rapid, complete acid digestion prior to analysis by flame atomic absorption (FAA), heated graphite furnace atomic absorption (HGFAA), and inductively coupled plasma spectroscopy (ICP) [13].

Apparatus and Materials [14-19]

1. Microwave unit, to provide programmable power with a minimum of 574 W and programmable to within ± 10 W of the required power.
2. The microwave unit cavity shall be corrosion resistant as well as ventilated. All electronics are protected against corrosion for safe operation.
3. The system requires microwave transparent and reagent resistant vessels, such as perfluoroalkoxy alkane (PFA) digestion vessels (120-mL capacity), capable of withstanding pressures up to 7.5 ± 0.7 atm (760 ± 70 kPa). Vessels shall also be capable of controlled pressure relief at pressures exceeding 7.5 ± 0.7 atm (760 ± 70 kPa). Other, equivalent types of vessels designed to operate at temperatures and pressures required and recommended by manufacturer can be used.
4. A rotating turntable is employed to ensure homogeneous distribution of microwave radiation within the unit. The speed of the turntable should be a minimum of 3 rpm.
5. A safety concern relates to the use of sealed containers without pressure relief valves in the unit. Temperature is the important variable controlling the reaction. Pressure is needed to attain elevated temperatures but must be safely contained [15].
6. Polymeric volumetric ware in plastic (PTFE or polyethylene), 50- or 100-mL capacity.
7. Disposable polypropylene filter funnel.
8. Analytical balance, 300-g capacity, and minimum ± 0.001 g.

Reagents

1. Nitric acid, concentrated, spectroscopy grade.
2. Reagent Water. Reagent water shall be interference free. All references to water in the method refer to reagent water that meets the ASTM Type 2 standard.

Procedure

1. Calibration of Microwave Equipment
 - a. Calibrate microwave equipment in accordance with manufacturer's instructions. If calibration instructions are not available, see EPA Method 3051 [14].
2. All digestion vessels and volumetric ware must be carefully acid washed and rinsed with reagent water. All digestion vessels should be cleaned by leaching with hot (1:1) nitric acid for a minimum of fifteen minutes, rinsed with reagent water, and dried in a clean environment
3. Sample Digestion
 - a. Tare the PFA digestion vessel.
 - b. Weigh out 0.1 g paint chip sample to the nearest 0.001 g into the tared PFA sample vessel. With large paint chip samples, measure out a 2 cm² piece, weigh to the nearest 0.001 g, and quantitatively transfer it to the vessel.

- c. Add 5.0 ± 0.1 mL concentrated nitric acid to the sample vessel in a fume hood. If a vigorous reaction occurs, allow the reaction to stop before capping the vessel. Cap the vessel and torque the cap to 16 N-m according to the manufacturer's directions. The sample vessel may be connected to an overflow vessel using PFA connecting tubes. Place the vessels in the microwave carousel. Connect the overflow vessels to the center well of the unit.
- d. Place the vessels evenly distributed in the turntable of the microwave unit. Any vessels containing 5 mL of nitric acid for reagent blank purposes are counted as sample vessels. When fewer than the recommended number of samples are to be digested, i.e., three samples plus one blank, the remaining vessels should be filled with 5 mL of nitric acid to achieve the full complement of vessels. This provides an energy balance since the microwave power absorbed is proportional to the total mass in the cavity [17]. Irradiate each group of samples to achieve a temperature of 180 °C. Temperature ramp times should be appropriate for the vessels used. A sample digestion program for 12 samples is presented in Table A1. Adjust power values depending upon the number of samples included in the microwave at one time.

TABLE A1. PROGRAM VARIABLES FOR PAINT CHIPS SAMPLE DIGESTION WITH NITRIC ACID^A

| | Stage 1 | Stage 2 | Stage 3 |
|-------------------------|----------------|----------------|----------------|
| Power | 90% | 90% | 0% |
| Pressure (kPa) | 375 | 750 | --- |
| Run time (min) | 10 | 20 | 5 |
| Time @ P (min) | 5 | 15 | --- |
| Temperature (°C) | 180 | 180 | None applied |

^AFor 12 microwave vessels that contain 0.1 g of sample and 5 mL of liquid per vessel

- e. At the end of the microwave program, allow the vessels to cool to a temperature below the boiling point of concentrated nitric acid (or that of the acid mixture used) before removing them from the microwave unit. If sample loss is detected (e.g., material in overflow collection vessel, liquid outside liner), determine the reason for the loss (e.g., loss of vessel seal integrity, use of a digestion time longer than 30 minutes, too large a sample, or improper heating conditions). Once the source of the loss has been corrected, prepare a new sample beginning at step 2. If insufficient material is available for reanalysis, dilute remaining digestate and note that some sample loss may have occurred.
 - f. Uncap and vent each vessel in a fume hood. Transfer the sample to an acid-cleaned polyethylene bottle. Dilute to 25 mL using reagent water. If the digested sample contains particulates which may clog nebulizers or interfere with injection of the sample into the instrument, allow the sample to settle or filter it:
 - Settling: Allow the sample to stand until the supernatant is clear (usually overnight is sufficient). If it does not filter the sample.
 - Filtering: Filter using disposable syringe filters, filter apparatus, etc. The filtering apparatus must be thoroughly precleaned and rinsed with dilute nitric acid. Filter the sample through quantitative filter paper into a second acid-cleaned container.
 The digestate is now ready for analysis for elements of interest using the appropriate method.
4. Calculations: Report the concentrations based on the actual weight of the original sample.

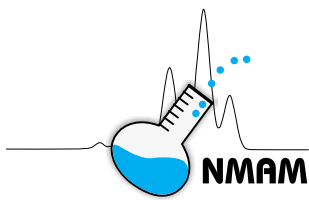

| AW: Table 1 | | CAS: Table 2 | | RTECS: Table 2 | | |
|---|-----------|----------------------------|--|-----------------------|-----------|-----------|
| METHOD: 7302, Issue 1 | | EVALUATION: FULL | | Issue 1: 21 July 2014 | | |
| OSHA: Table 2 NIOSH: Table 2 Other OELs: [1,2] | | PROPERTIES: Table 1 | | | | |
| ELEMENTS: | aluminum | cadmium | lead | phosphorus | strontium | yttrium |
| | antimony | calcium | lithium | platinum | tellurium | zinc |
| | arsenic | chromium | magnesium | potassium | thallium | zirconium |
| | barium | cobalt | manganese | selenium | tin | |
| | beryllium | copper | molybdenum | silver | titanium | |
| | boron | iron | nickel | sodium | vanadium | |
| SAMPLING | | | MEASUREMENT | | | |
| SAMPLER: FILTER (mixed cellulose ester membrane (MCE), 37-mm diameter, 0.8- μ m pore size) FLOW RATE: 1 to 4 L/min VOL-MIN: -MAX: Table 1 SHIPMENT: Routine SAMPLE STABILITY: Stable BLANKS: 2 to 10 field blanks per set | | | TECHNIQUE: INDUCTIVELY COUPLED ARGON PLASMA, ATOMIC EMISSION SPECTROSCOPY (ICP-AES) ANALYTE: Elements listed above REAGENTS: 10.0 mL of 1:1 nitric (HNO ₃) and ASTM Type II water FINAL SOLUTION: 20% HNO ₃ , 25 mL WAVELENGTH: Depends upon element (see Table 3) BACKGROUND CORRECTION: Spectral wavelength shift CALIBRATION: Elements in 20% HNO ₃ RANGE: See Table 4 ESTIMATED LOD: Table 3 PRECISION ($\hat{\sigma}_r$): Table 3 | | | |
| ACCURACY | | | | | | |
| RANGE STUDIED: See Table 4 ACCURACY: See Table 4 BIAS: See Table 4 OVERALL PRECISION ($\hat{\sigma}_{IT}$): See Table 4 | | | | | | |
| APPLICABILITY: This method is for the analysis of metal and nonmetal dust collected on MCE filters in the workplace. The working range varies from element to element. The method entails simultaneous elemental analysis using a microwave digestion approach to simplify and expedite the analysis. | | | | | | |
| INTERFERENCES: Spectral interferences are the primary interferences encountered in ICP-AES analysis. These are minimized by judicious wavelength selection, inter-element correction factors and background correction [3]. | | | | | | |
| OTHER METHODS: This method complements NIOSH hotplate digestion methods 7300 and 7301 for trace elements. Flame atomic absorption spectroscopy (e.g., Methods 7013 through 7082) is an alternative analytical technique for many of these elements [4]. Graphite furnace AAS (e.g., 7102 for Be, 7105 for Pb) is usually more sensitive [4]. NMAM 7301 and 7303 contain alternative extraction procedures. | | | | | | |

REAGENTS:

1. Nitric acid, conc., trace metal grade*
2. Calibration stock solutions, 1000 µg/mL and 10,000 µg/mL commercially available, or prepared per instrument manufacturer's recommendation (see step 10)
3. Digestion acid*. 1:1 water, ASTM type II, and nitric acid*, trace metal grade
4. Argon, liquid
5. De-ionized Water, ASTM Type II [5]
6. Dilution acid*, 20% nitric acid in ASTM Type II water

* See Special Precautions

EQUIPMENT:

1. Sampler: mixed cellulose ester membrane (MCE) filter, 0.8-µm pore size, 37-mm diameter; in 2-piece cassette filter holder
2. Personal sampling pump, 1 to 4 L/min, with flexible connecting tubing
3. Inductively coupled plasma-atomic emission spectrometer, equipped as specified by the manufacturer for analysis of elements of interest
4. Regulator, two-stage for argon
5. Microwave, programmable power, active temperature control, minimum of 574 W, corrosion resistant ventilated oven and turntable
6. Microwave digestion vessels, high pressure, closed PTFE, 100-mL capacity
7. Volumetric flasks, 25 mL**
8. Assorted volumetric pipettes as needed**

** Acid wash all glassware and vessels before using.

SPECIAL PRECAUTIONS: Wear gloves, lab coat, and safety glasses while handling all chemicals. All work should be performed with adequate ventilation to personnel and equipment. Because this method involves the use of capped digestion containers, avoid the use of other acids such as perchloric acid in combination with nitric acid that could cause a violent reaction [6,7]. In the preparation of the digestion and dilution acids, it is imperative that acid be added to water in order to avoid a violent exothermic reaction.

SAMPLING

1. Calibrate each personal sampling pump with a representative sampler connected to the pump (in line).
2. Sample at an accurately known flow rate between 1 and 4 L/min. For estimated sampling volumes see Table 1. For TWA measurements see Table 2. Do not exceed a filter loading of approximately 2 mg total dust.

NOTE: Filter overloading can be assessed by periodic visual checks. See NMAM guidance chapters for discussion on sampling.

SAMPLE PREPARATION

NOTE: If total weights are desired, weighing should be done at this step. Follow NIOSH method 0500 for gravimetric analysis [11].

3. Open the cassette filter holders and transfer the samples, blanks, and Quality Control (QC) filters to clean PTFE digestion vessels. Wipe the internal cassette surfaces with a 37-mm MCE filter, polyvinyl alcohol wipe or cellulosic wipe wetted with deionized water, and add to the digestion vessel to transfer non-filter aerosol deposits into the digestion vessels.
4. Add digestion acid up to 10 mL, and cap the vessels.

NOTE: In order to avoid a violent exothermic reaction, do not add water to concentrated nitric acid. Acid should be added after the water has been placed in the vessel.

5. Place digestion vessels in microwave, and run the preprogrammed digestion procedure for 12- vessel digestion: 1200 W power, ramp to 150 °C over 20 min, hold for 10 min at 150 °C followed by at least a 5 min cool down (power will be adjusted lower for fewer vessels).
6. Allow the samples to cool to room temperature.
7. Remove vessel lids and rinse contents into 25-ml volumetric flasks with ASTM Type II water.
8. Dilute to the mark with ASTM Type II water and mix.
9. Submit extracted and diluted samples for analysis.

CALIBRATION AND QUALITY CONTROL

10. Calibrate the spectrometer according to the manufacturer recommendations.

NOTE: Typically an acid blank and multi-element working standards are used. The following multi-element combinations are chemically compatible in 20% HNO₃.

- a. Al, As, Ba, Be, Ca, Co, Cr, Cu, Fe, Li, Mg, Mn, Mo, Na, Ni, Pb, Se, Sr, Ti, V, Y, Zn, Zr;
 - b. B, K, P, Sn, Te, Tl;
 - c. Ag, Cd, Sb;
 - d. Pt.
11. Analyze all applicable standards at least once every twenty (20) analyses (minimum frequency 5%).
 12. Check recoveries with at least one media blank and two spiked media blanks per twenty samples. Use a spike level that is within the range of 10 to 20 times the LOQ.

NOTE: Whenever possible, QA/QC samples should be prepared from certified reference materials in a matrix similar to the bulk material sampled. Liquid spiked filters are only surrogates for real world samples and QC data based upon certified samples are preferred.

MEASUREMENT

13. Set ICP-AES spectrometer to conditions specified by manufacturer.
14. Analyze standards and samples at applicable wavelengths for each element (target analytes are in Table 3).

NOTE: If the values for the samples are above the linear range of the instrument, dilute the solutions with dilution acid, reanalyze, and apply the appropriate dilution factor in calculations.

CALCULATIONS

15. Obtain the solution concentrations for the sample, C_s (µg/mL), and the average media blank, C_b (µg/mL), from the instrument.
16. Using the solution volume of sample, V_s (mL), and media blank, V_b (mL), calculate the concentration for the sample, C (mg/m³), of each element in the air volume sampled, V (L), as follows:

$$C = \frac{(C_s V_s) - (C_b V_b)}{V} \quad , \text{mg/m}^3$$

NOTE: µg/Liter is essentially equal to mg/m³.

EVALUATION OF METHOD

Method 7302 was evaluated using multi-element filter spikes at six spiking levels, based on the estimated LOQ for each element [8]. Using microwave digestion is less time consuming and more convenient than

using the traditional mixed acid hot plate approach. The elimination of perchloric acid in the sample digestion procedure helps to improve the safety of the method. [7]

Summary data are presented in Table 3 for levels 3X LOQ (lower level in Table 3) and 300X LOQ (higher level in Table 3) and for the ranges of loadings given in Table 4. Samples were subjected to microwave digestion using a CEM MDS-2100 device according to the conditions specified in the "sample preparation" section above (see Note of step #5). The values in Tables 3 and 4 were determined using several different ICP-AES instruments which were operated according to manufacturer's instructions. The precision and recovery data, instrumental detection limits, sensitivity, and analytical wavelengths are listed in Table 3 and Table 4. All of the precision data were evaluated for homogeneity for all six concentration levels tested using the Bartlett's test and the results are listed in the method backup data report [8] and summarized in Tables 3 and 4. A statistical analysis found that the data were poolable and all elements had calculated method precision accuracies of less than 25%. This overall precision (\hat{S}_{rT}) and accuracy as given in Table 4 is an upper limit predictor of precision. Accuracy data (Table 4) demonstrate the utility of the method for all of the elements listed.

A discussion of metals and metalloid analysis by ICP-AES is presented in an international voluntary consensus standard [3] and the microwave digestion procedure has been evaluated against other digestion procedures through an interlaboratory trial [10].

REFERENCES

- [1] ACGIH [2013]. TLVs and BEIs based on the documentation of the Threshold Limit Values for chemical substances and physical agents and Biological Exposure Indices. Cincinnati, Ohio: American Conference of Governmental Industrial Hygienists. [www.acgih.org]. [Data accessed April 2014.]
- [2] Institut für Arbeitsschutz der Deutschen Gesetzlichen Unfallversicherung [2013]. GESTIS database on hazardous substances (German Social Accident Insurance). Sankt Augustin, FRG: [http://www.dguv.de/ifa/GESTIS]. [Data accessed April 2014.]
- [3] ASTM [2010]. ASTM D7035-10, Standard test method for the determination of metals and metalloids in airborne particulate matter by inductively coupled plasma atomic emission spectrometry. West Conshohocken, PA: ASTM International [www.astm.org].
- [4] NIOSH [1994] NIOSH Manual of analytical methods (NMAM). 4th ed. Schlecht PC, O'Connor PF, eds. Cincinnati, OH: U.S. Department of Health and Human Services, Centers for Disease Control and Prevention, National Institute for Occupational Safety and Health, DHHS (NIOSH) Publication No. 94-113 [www.cdc.gov/niosh/nmam/].
- [5] ASTM International [2011]. ASTM D1193-77, Standard specification for reagent water. West Conshohocken, PA: ASTM International [www.astm.org].
- [6] NIOSH [2005]. NIOSH Pocket guide to chemical hazards. Barsan ME, ed. Cincinnati, OH: US Department of Health and Human Services, Centers for Disease Control and Prevention, National Institute for Occupational Safety and Health, DHHS (NIOSH) Publication No. 2005-149.
- [7] Furr AK, ed. [1995]. CRC Handbook of laboratory safety, 4th ed. Boca Raton, FL: CRC Press.
- [8] Stone LC, Perkins JB, Rogers DM [2003]. Elements by ICP using microwave digestion, NMAM 7302, Issue 1, Backup data report. Cincinnati OH: Datachem Laboratory developed under contract CDC-200-2001-08000. Unpublished.
- [9] Lide DR, ed. [1994] Handbook of chemistry and physics. 74th ed. Boca Raton, FL.: CRC Press.
- [10] Butler OT, Howe AM [1999]. Development of an international standard for the determination of metals and metalloids in workplace air using ICP-AES: Evaluation of sample dissolution procedures through an interlaboratory trial. J. Environ. Monit. 1: 23-32.
- [11] Code of Federal Regulations, 29 CFR Part 1910.1000 (Table Z-1) [https://www.osha.gov/pls/oshaweb/owadisp.show_document?p_table=STANDARDS&p_id=9992]. Website accessed on December 13, 2013.

METHOD WRITTEN BY:

David M. Rogers, Lee C. Stone, James B. Perkins, DataChem Laboratories, Salt Lake City, Utah.; Yvonne Gagnon, Ronnee Andrews, Ph.D., NIOSH/DART.

Disclaimer: Mention of any company or product does not constitute endorsement by NIOSH. In addition, citations to websites external to NIOSH do not constitute NIOSH endorsement of the sponsoring organizations or their programs or products. Furthermore, NIOSH is not responsible for the content of these websites. All web addresses referenced in this document were accessible as of the publication date.

TABLE 1. PROPERTIES AND SAMPLING VOLUMES

| Element (Symbol) | Properties [9] | | Air Volume, L @ OSHA PEL [11] | |
|-------------------------------|----------------|--------|----------------------------------|---------------------|
| | Atomic Weight | MP, °C | MIN | MAX |
| Aluminum (Al) | 26.98 | 660 | 5 | 100 |
| Antimony (Sb) | 121.8 | 630 | 10 ⁽²⁾ | 2000 ⁽²⁾ |
| Arsenic (As) | 74.92 | 817 | 5 | 2000 |
| Barium (Ba) | 137.3 | 727 | 5 ⁽²⁾ | 200 ⁽²⁾ |
| Beryllium (Be) | 9.01 | 1287 | 1250 | 2000 |
| Boron (B) ⁽¹⁾ | 10.81 | 2300 | 5 | 2000 |
| Cadmium | 112.41 | 321 | 12 | 2000 |
| Calcium (Ca) ⁽¹⁾ | 40.08 | 842 | 5 | 200 |
| Chromium (Cr) | 52.00 | 1907 | 5 | 1000 |
| Cobalt (Co) | 58.93 | 1495 | 25 | 2000 |
| Copper (Cu) | 63.54 | 1083 | 5 | 1000 |
| Iron (Fe) | 55.85 | 1535 | 5 | 100 |
| Lead (Pb) | 207.19 | 328 | 50 | 2000 |
| Lithium (Li) ⁽¹⁾ | 6.94 | 181 | 100 | 2000 |
| Magnesium (Mg) | 24.31 | 651 | 5 | 67 |
| Manganese (Mn) | 54.94 | 1245 | 5 | 200 |
| Molybdenum (Mo) | 95.94 | 2623 | 5 | 67 |
| Nickel (Ni) | 58.71 | 1455 | 5 | 1000 |
| Phosphorus (P) | 30.97 | 44 | 25 | 2000 |
| Platinum (Pt) | 195.09 | 1769 | 1250 | 2000 |
| Potassium (K) ⁽¹⁾ | 39.10 | 64 | 5 | 2000 |
| Selenium (Se) | 78.96 | 221 | 13 | 2000 |
| Silver (Ag) | 107.87 | 961 | 250 | 2000 |
| Sodium (Na) ⁽¹⁾ | 22.99 | 98 | 13 | 2000 |
| Strontium (Sr) ⁽¹⁾ | 87.62 | 777 | 5 | 2000 |
| Tellurium (Te) | 127.60 | 450 | 25 | 2000 |
| Tin (Sn) | 118.69 | 232 | 20 ⁽²⁾ | 2000 ⁽²⁾ |
| Thallium (Tl) | 204.37 | 304 | 25 | 2000 |
| Titanium (Ti) | 47.87 | 1668 | 5 | 100 |
| Vanadium (V) | 50.94 | 1910 | 5 | 2000 |
| Yttrium (Y) | 88.91 | 1522 | 5 | 1000 |
| Zinc (Zn) | 65.37 | 419 | 5 | 200 |
| Zirconium (Zr) | 91.22 | 1855 | 5 | 200 |

⁽¹⁾ No PEL, REL, or STEL data found [1,6,11].

⁽²⁾ Air volumes estimated from TWAs and LOQs (see Tables 2, 3) [1].

TABLE 2. EXPOSURE LIMITS, CAS #, RTECS [1,6,11]

| Element (Symbol) | CAS # | RTECS | Exposure Limits in mg/m ³ (C = ceiling limit) | |
|---------------------|------------|-----------|--|--|
| | | | OSHA | NIOSH |
| Aluminum (Al) | 7429-90-5 | BD0330000 | 15 (total dust) 5 (respirable) | 10 (total dust), 2 (soluble) 5 (respirable, fume) |
| Arsenic (As) | 7440-38-2 | CG0525000 | 0.010 (inorganic) | C 0.002 ⁽¹⁾ , 0.5 |
| Barium (Ba) | 7440-39-3 | | 0.5 (Soluble compounds, as Ba) | 0.5 (Soluble compounds, as Ba) |
| Beryllium (Be) | 7440-41-7 | DS1750000 | 0.002, C 0.005 | C 0.0005 ⁽¹⁾ |
| Boron (B) | 7440-42-8 | ED7350000 | 15 as oxide | 10 as oxide |
| Cadmium (Cd) | 7440-43-9 | EU9800000 | 0.005 | lowest feasible conc. ⁽¹⁾ |
| Calcium (Ca) | 7440-70-2 | EV8040000 | No OELs | No OELs |
| Chromium (Cr) | 7440-47-3 | GB4200000 | 0.5 (II & III), 0.005 (VI) 1 (metals, insoluble salts) | 0.5 |
| Cobalt (Co) | 7440-48-4 | GF8750000 | 0.1 (dust, fume) | 0.05 (dust, fume) |
| Copper (Cu) | 7440-50-8 | GL5325000 | 1(dust, mists) 0.1 (fume) | 1 (dust, mists) 0.1 (fume) |
| Iron (Fe) | 7439-89-6 | NO4565500 | 10 (fume) as oxide | 5 (dust, fume) as oxide |
| Lead (Pb) | 7439-92-1 | OF7525000 | 0.05 | 0.05 |
| Lithium (Li) | 7439-93-2 | OJ5540000 | | |
| Magnesium (Mg) | 7439-95-4 | OM2100000 | 15 (dust) as oxide | -- |
| Manganese (Mn) | 7439-96-5 | OO9275000 | C 5 | 1; STEL 3 |
| Molybdenum (Mo) | 7439-98-7 | QA4680000 | 5 (soluble) 15 (total insoluble) | |
| Nickel (Ni) | 7440-02-0 | QR5950000 | 1 | 0.015, Ca |
| Phosphorus (P) | 7723-14-0 | TH3500000 | 0.1 | 0.1 |
| Platinum (Pt) | 7440-06-4 | TP2160000 | 0.002 (soluble) | 1 (metal) 0.002 (soluble) |
| Potassium (K) | 7740-09-7 | TS6460000 | | |
| Antimony (Sb) | 7440-36-0 | CC4025000 | 0.5 | 0.5 |
| Selenium (Se) | 7782-49-2 | VS7700000 | 0.2 | 0.2 |
| Silver (Ag) | 7440-22-4 | VW3500000 | 0.01 (dust, fume, metal) | 0.01 (dust, fume, metal) |
| Sodium (Na) | 7440-23-5 | VY0686000 | | |
| Strontium (Sr) | 7440-24-6 | WK7700000 | | |
| Tellurium (Te) | 13494-80-9 | WY2625000 | 0.1 | 0.1 |
| Tin (Sn) | 7440-31-5 | XP7320000 | 2 | 2 |
| Titanium (Ti) | 7440-32-6 | XR1700000 | 15 (as TiO ₂) | lowest feasible ⁽¹⁾ |
| Thallium (Tl) | 7440-28-0 | XG3425000 | 0.1 (soluble) skin | 0.1 (soluble) skin |
| Vanadium (V) | 7440-62-2 | YW1355000 | C 0.5 (respirable) as V ₂ O ₅ C 0.1 (fume) as V ₂ O ₅ | C 0.05 as V ₂ O ₅ |
| Yttrium (Y) | 7440-65-5 | ZG2980000 | 1 | 1 |
| Zinc (Zn) | 7440-66-6 | ZG8600000 | 5 (ZnO fume) 15 (ZnO dust) 5 (ZnO respirable) | 5; STEL 10 (ZnO fume) 5; C 15 (ZnO dust) |
| Zirconium (Zr) | 7440-67-7 | ZH7070000 | 5 | 5, STEL 10 |

(1) Carcinogen

TABLE 3. MEASUREMENT WAVELENGTHS AND RECOVERY DATA [8]

| Element ⁽¹⁾ | Wavelength (nm)[6] | LOD (µg/sample) | Lower Level | | | Higher Level | | |
|------------------------|-----------------------|--------------------|-------------|--------------------|-------|--------------|---------------------|-------|
| | | | µg/sample | % Recovery N=6) | % RSD | µg/sample | % Recovery (N=6) | % RSD |
| Ag | 328.1 | 0.1 | 1.50 | 95.5 | 1.01 | 150 | 99.0 | 0.497 |
| Al | 308.2 | 1 | 7.50 | 92.7 | 0.981 | 750 | 98.7 | 0.462 |
| As | 193.8 | 1 | 7.50 | 101 | 2.22 | 750 | 107 | 0.340 |
| B | 249.7 | 0.5 | 3.75 | 112 | 2.96 | 375 | 99.5 | 0.454 |
| Ba | 493.4 | 0.06 | 0.752 | 104 | 3.09 | 75.2 | 101 | 0.438 |
| Be | 313.0 | 0.009 | 0.076 | 95.8 | 2.36 | 7.60 | 103 | 0.714 |
| Ca | 315.9 | 2 | 22.5 | 107 | 2.87 | 2250 | 99.0 | 0.620 |
| Cd | 228.8 | 0.1 | 1.50 | 98.8 | 3.46 | 150 | 104 | 0.701 |
| Co | 228.6 | 0.3 | 3.75 | 99.7 | 1.72 | 375 | 104 | 0.566 |
| Cr ⁽²⁾ | 267.7 | 0.4 | 3.75 | 103 | 7.87 | 375 | 103 | 3.36 |
| Cu | 324.8 | 0.07 | 0.752 | 98.8 | 3.47 | 75.2 | 94.2 | 0.371 |
| Fe | 259.9 | 2 | 15.0 | 112 | 2.43 | 1500 | 101 | 0.263 |
| K | 766.5 | 2 | 15.0 | 98.3 | 5.70 | 1500 | 103 | 0.472 |
| Li | 670.8 | 0.03 | 0.752 | 92.4 | 2.98 | 75.2 | 98.8 | 0.749 |
| Mg | 279.1 | 0.5 | 7.50 | 89.3 | 3.52 | 750 | 95.1 | 0.309 |
| Mn | 257.6 | 0.02 | 0.752 | 86.2 | 2.38 | 75.2 | 98.2 | 0.389 |
| Mo | 202.0 | 0.2 | 2.25 | 96.8 | 5.41 | 225 | 103 | 0.373 |
| Na | 589.0 | 4 | 37.5 | 100 | 0.823 | 3750 | 110 | 0.457 |
| Ni | 231.6 | 0.2 | 2.25 | 98.3 | 5.21 | 225 | 97.7 | 0.592 |
| P | 214.9 | 2 | 15.0 | 100 | 5.67 | 1500 | 104 | 0.315 |
| Pb | 220.4 | 0.6 | 7.50 | 98.9 | 3.94 | 750 | 104 | 0.570 |
| Pt ⁽²⁾ | 265.9 | 8 | 75.0 | 98.3 | 0.282 | 10000 | 95.7 | 1.49 |
| Sb | 206.8 | 0.4 | 7.50 | 94.4 | 3.21 | 750 | 103 | 0.255 |
| Se | 196.1 | 3 | 37.5 | 104 | 3.21 | 3750 | 106 | 0.270 |
| Sn ⁽²⁾ | 189.9 | 0.8 | 37.5 | 105 | 5.04 | 3750 | 90.3 | 3.23 |
| Sr | 421.6 | 0.02 | 3.75 | 92.6 | 2.36 | 375 | 97.5 | 0.553 |
| Te ⁽²⁾ | 214.3 | 2 | 15.0 | 90.1 | 21.8 | 1500 | 103 | 0.614 |
| Ti | 337.3 | 0.2 | 1.50 | 101 | 1.70 | 150 | 98.8 | 0.575 |
| Tl | 190.9 | 0.9 | 7.5 | 103 | 4.14 | 750 | 99.3 | 0.352 |
| V | 292.4 | 0.1 | 0.752 | 93.7 | 4.74 | 75.2 | 103 | 0.341 |
| Y ⁽²⁾ | 371.0 | 0.02 | 0.376 | 107 | 4.44 | 37.6 | 102 | 3.33 |
| Zn ⁽²⁾ | 213.9 | 0.1 | 1.50 | 106 | 13.1 | 150 | 97.4 | 3.42 |
| Zr | 339.2 | 0.06 | 0.750 | 93.1 | 5.35 | 75.0 | 95.4 | 0.971 |

(1) Values reported were obtained with a Fisons ARL Accuris ICP-AES; performance may vary with instrument and should be independently verified.

(2) Values reported were obtained with a Perkin Elmer Optima 3000 DV ICP-AES. Sample concentration was based on Fisons ICP LOD data.

TABLE 4. PRECISION AND ACCURACY DATA BY ELEMENT [8]

| Element ($\mu\text{g}/\text{sample}$) | Range ($\mu\text{g}/\text{sample}$) | Bias | \hat{S}_{RT}(%) | Accuracy |
|---|---|-------------|--|-----------------|
| Ag | 0.5 to 150 | -0.0175 | 0.668 | 2.85 |
| Al | 2.5 to 750 | 0.0505 | 1.455 | 7.41 |
| As | 2.5 to 750 | -0.2249 | 0.554 | 23.40 |
| Ba | 0.25 to 75.2 | -0.0330 | 0.920 | 4.82 |
| Be | 0.025 to 7.60 | 0.0297 | 0.863 | 4.39 |
| Ca | 7.43 to 2250 | -0.0081 | 0.836 | 2.18 |
| Cd | 0.50 to 150 | -0.0082 | 0.729 | 2.02 |
| Co | 1.24 to 375 | -0.0161 | 0.574 | 2.56 |
| Cr | 1.24 to 375 | -0.0204 | 0.655 | 3.12 |
| Cu | 0.248 to 75.2 | 0.0160 | 0.984 | 3.21 |
| Fe | 5.00 to 1500 | -0.0039 | 1.637 | 3.30 |
| K | 5.00 to 1500 | 0.1487 | 1.665 | 17.61 |
| La | 12.6 to 50.1 | -0.0136 | 0.920 | 2.87 |
| Li | 0.25 to 75.2 | 0.2241 | 1.209 | 24.40 |
| Mg | 2.5 to 750 | 0.0180 | 0.844 | 3.19 |
| Mn | 0.25 to 75.2 | -0.0348 | 0.865 | 4.91 |
| Mo | 0.75 to 225 | 0.0140 | 1.469 | 3.82 |
| Ni | 0.75 to 225 | -0.0063 | 0.672 | 1.73 |
| P | 5.0 to 1500 | 0.0669 | 1.212 | 8.69 |
| Pb | 2.5 to 750 | -0.0246 | 0.544 | 3.36 |
| Sb | 2.5 to 750 | 0.0172 | 0.722 | 2.91 |
| Se | 12.4 to 3750 | 0.0538 | 0.758 | 6.63 |
| Sn | 12.4 to 3750 | 0.0561 | 0.936 | 7.15 |
| Sr | 1.24 to 375 | -0.0074 | 0.710 | 1.90 |
| Te | 5.0 to 1500 | 0.0161 | 0.892 | 3.08 |
| Ti | 0.5 to 150 | 0.0212 | 1.043 | 3.84 |
| Tl | 2.5 to 750 | -0.0293 | 0.602 | 3.92 |
| V | 0.25 to 75.2 | 0.0175 | 1.223 | 3.76 |
| Y | 0.12 to 37.6 | -0.0179 | 1.115 | 3.62 |
| Zn | 0.5 to 150 | 0.0075 | 1.343 | 3.02 |
| Zr | 0.25 to 75.0 | 0.0314 | 0.980 | 4.76 |

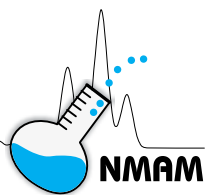

MW: Table 1

CAS: Table 2

RTECS: Table 2

METHOD: 7304, Issue 1

EVALUATION: FULL

Issue 1: 25 May 2014

OSHA: Table 2
 NIOSH: Table 2
 Other OELs: [1,2]

PROPERTIES: Table 1

| ELEMENTS: | aluminum | cadmium | iron | molybdenum | selenium | titanium |
|-----------|-----------|----------|-----------|------------|-----------|-----------|
| | arsenic | calcium | lead | nickel | sodium | vanadium |
| | barium | chromium | lithium | phosphorus | strontium | yttrium |
| | beryllium | cobalt | magnesium | platinum | tellurium | zinc |
| | boron | copper | manganese | potassium | thallium | zirconium |

SAMPLING

MEASUREMENT

SAMPLER: FILTER, (polyvinyl chloride (PVC), 37-mm diameter, 5.0 µm pore size)

FLOW RATE: 1 to 4 L/min

VOL-MIN:
 -MAX: Table 1

SHIPMENT: Routine

SAMPLE STABILITY: Stable

BLANKS: 2 to 10 field blanks per set

TECHNIQUE: INDUCTIVELY COUPLED ARGON PLASMA, ATOMIC EMISSION SPECTROSCOPY (ICP-AES)

ANALYTE: Elements listed above

REAGENTS: 12 mL of 5:1 concentrated nitric acid and ASTM Type II water

FINAL SOLUTION: 20% HNO₃, 50 mL

WAVELENGTH: Depends upon element; Table 3

BACKGROUND CORRECTION: Spectral wavelength shift

CALIBRATION: Elements in 20% HNO₃

RANGE: See Table 4

ESTIMATED LOD: Table 3

PRECISION (\bar{S}_r): Table 3

ACCURACY

RANGE STUDIED: See Table 4

ACCURACY: See Table 4

BIAS: See Table 4

OVERALL PRECISION (\hat{S}_r): See Table 4

APPLICABILITY: The working range of this method varies from element to element. This method is for the analysis of metal and nonmetal dust collected on PVC filters that are also used for gravimetric analysis. This is a simultaneous elemental analysis using a microwave digestion approach to simplify and expedite the analysis. Some elements such as antimony, silver, and tin do not form stable solutions in nitric acid when chloride from the PVC filters is present. In such cases a mixed cellulose ester (MCE) filter is necessary (See NMAM 7302). A different acid medium also helps but this technique is not described in this method.

INTERFERENCES: Spectral interferences are the primary interferences encountered in ICP-AES analysis. These are minimized by judicious wavelength selection, inter-element correction factors and background correction. [3,4,5,6]

OTHER METHODS: This method complements NIOSH hotplate digestion methods 7300 and 7301 for trace elements. Flame atomic absorption spectroscopy (e.g., Methods 70XX) is an alternative analytical technique for many of these elements. [7] Graphite furnace AAS (e.g., 7102 for Be, 7105 for Pb) is usually more sensitive. [7] NMAM 7301 and 7303 contain alternative extraction procedures.

REAGENTS

1. Nitric acid, conc., trace metal grade*
2. Calibration stock solutions, 1000 ug/mL and 10,000 ug/mL commercially available, or prepared per instrument manufacturer recommendation (see step 10)
3. Argon, liquid
4. De-ionized Water, ASTM Type II [8]
5. Dilution acid: 20% nitric acid in ASTM Type II water*

* See SPECIAL PRECAUTIONS

EQUIPMENT

1. Sampler: Polyvinyl chloride filter, 5.0- μ m pore size, 37-mm diameter; in 2-piece cassette filter holder
2. Personal sampling pump, 1 to 4 L/min, with flexible connecting tubing
3. Inductively coupled plasma-atomic emission spectrometer, equipped as specified by the manufacturer for analysis of elements of interest
4. Regulator, two-stage for argon
5. Microwave, programmable power, active temperature control, minimum of 574 W, corrosion resistant ventilated oven and turntable
6. Microwave digestion vessels, high pressure, closed PTFE, 100-mL capacity
7. Volumetric flasks, 50 mL**
8. Assorted volumetric pipettes as needed**

** Acid wash all glassware and vessels before using.

SPECIAL PRECAUTIONS: Wear gloves, lab coat, and safety glasses while handling all chemicals. All work should be performed with adequate ventilation to personnel and equipment. Because this method involves the use of capped digestion containers, avoid the use of other acids such as perchloric acid in combination with nitric acid that could cause a violent reaction [1,9]. In the preparation of the digestion and dilution acid, it is imperative that acid be added to water in order to avoid a violent exothermic reaction.

SAMPLING:

1. Calibrate each personal sampling pump with a representative sampler connected to the pump (in line.)
2. Sample at an accurately known flow rate between 1 and 4 L/min. For estimated sampling volumes see Table 1. For TWA measurements see Table 2. Do not exceed a filter loading of approximately 2 mg total dust.

NOTE: Filter overloading can be assessed by periodic visual checks. See NMAM guidance chapters for additional discussion on filter capacity.

SAMPLE PREPARATION:

NOTE: If total weights are desired, it should be done at this step. Follow NIOSH method 0500 for gravimetric analysis [12].

3. Open the cassette filter holders and transfer the samples, blanks, and Quality Control (QC) filters to clean PTFE digestion vessels. Wipe the internal cassette surfaces with a 37 mm PVC filter wetted with deionized water and add to the digestion vessel to transfer non-filter aerosol deposits into the digestion vessels.
4. Add 2 mL of ASTM Type II water followed by adding (slowly) 10 mL concentrated nitric acid, then cap each vessel.

NOTE: In order to avoid a violent exothermic reaction, do not add water to concentrated nitric acid. Acid should be added after the water has been placed in the vessel.

5. Place digestion vessels in microwave and run preprogrammed PVC digestion procedure. Example microwave conditions for 12-vessel digestion: 1200 W power, ramp to 215 °C over 20 min, hold for 10 min at 215 °C followed by at least a 5 min cool down (power will be adjusted lower for fewer vessels).
6. Allow the samples to cool to room temperature.
7. Remove vessel lids and rinse contents into 50-mL volumetric flasks with ASTM Type II water.
8. Dilute to the mark with ASTM Type II water and mix.
9. Submit samples for analysis.

NOTE: A residual solid may be present after digestion. Filter/centrifuge the samples before analysis, as appropriate.

CALIBRATION AND QUALITY CONTROL:

10. Calibrate the spectrometer according to the manufacturers' recommendations.

NOTE: Typically an acid blank and a single or multi-element working standard are used. The following multi-element combinations are chemically compatible in 20% HNO₃.

- a. Al, As, Ba, Be, Ca, Co, Cr, Cu, Fe, Li, Mg, Mn, Mo, Na, Ni, Pb, Se, Sr, Ti, V, Y, Zn, Zr;
- b. B, K, P, Te, Tl;
- c. Cd;
- d. Pt.

11. Analyze all applicable standards at least once every twenty (20) analyses (minimum frequency 5%).
12. Check recoveries with at least one media blank and two spiked media blanks per twenty samples.

Use a spike level that is within the range of 10 to 20 times the Limit of Quantitation (LOQ.)

NOTE: Whenever possible, QA/QC samples should be prepared from certified reference materials in a matrix similar to the bulk material sampled. Liquid spiked filters are only surrogates for real world samples and QC data based upon certified samples would be ideal.

MEASUREMENT:

13. Set the ICP-AES spectrometer to conditions specified by manufacturer.
14. Analyze standards and samples at applicable wavelengths for each element (target analytes are in Table 3).

NOTE: If the values for the samples are above the linear range of the instrument, dilute the solutions with dilution acid, reanalyze, and apply the appropriate dilution factor in the calculations.

CALCULATIONS:

15. Obtain the solution concentrations for the sample, C_s (µg/mL), and the average media blank, C_b (µg/mL), from the instrument.
16. Using the solution volume of sample, V_s (mL), and media blank, V_b (mL), calculate the concentration for the sample, C (mg/m³), of each element in the air volume sampled, V (L), as follows:

$$C = \frac{(C_s V_s) - (C_b V_b)}{V}, \text{ mg/m}^3$$

NOTE: µg/Liter is approximately equal to mg/m³.

EVALUATION OF METHOD:

This method is less time consuming and more convenient than using the acid hotplate approach. The elimination of perchloric acid in the sample digestion procedure helps to improve the safety of the method. [9] Use of the PVC filters allows for the acquisition of total mass per filter in addition to total metals concentration.

The evaluation of this method, 7304, for PVC filters was determined at six concentration levels based on the LOQ for each element listed on page 1 [13]. All of the precision data was evaluated for homogeneity for all concentration levels tested using the Bartlett's test and the results are listed in the method backup data report [12] and summarized in Tables 3 and 4. In many cases the highest concentration level (300 times the LOQ) was not poolable due in every case to the precision being so small relative to the other values, usually less than $CV = 0.001$ ($<0.1\%$). Therefore, the overall precision (\hat{S}_{rr}) and accuracy as given in Table 4 is an upper limit predictor of precision; precision at concentration levels greater than 300 times the LOQ (see Table 3) will probably be much smaller.

For many of the metals, precision at the 3 times and/or 1 times the LOQ levels was reasonable (CV less than 10%) but were not poolable due to the precisions at the higher concentration levels being so much smaller. In one case (strontium) the lowest level was not poolable because its CV was an inlier (less than 1%), being much smaller than those at the higher concentration levels. In most cases the precision appeared to be a function of concentration. This is observable in Table 3 where the CV s for the 10 times the LOQ (lower level) and 300 times the LOQ (higher) levels are compared.

Three elements, antimony, silver, and tin, had poor recoveries. It is believed that the chloride ions produced in the digestion of the PVC filters is causing the formation of precipitates. These metals are preferably sampled on MCE filters. The values in Tables 3 and 4 were determined using several different ICP-AES instruments and also several different microwave ovens. All were operated according to the manufacturer's instructions.

REFERENCES:

- [1] ACGIH [2013]. TLVs and BEIs based on the documentation of the Threshold Limit Values for chemical substances and physical agents and Biological Exposure Indices. Cincinnati, Ohio: American Conference of Governmental Industrial Hygienists. [www.acgih.org]. [Data accessed April 2014.]
- [2] Institut für Arbeitsschutz der Deutschen Gesetzlichen Unfallversicherung [2013]. GESTIS database on hazardous substances (German Social Accident Insurance). Sankt Augustin, FRG: [<https://www.dguv.de/ifa/index-2.jsp>]. [Data accessed April 2014.]
- [3] Hull, RD [1981]. Multi-element analysis of industrial hygiene samples, NIOSH internal report presented at the American Industrial Hygiene Conference, Portland, Oregon, May.
- [4] NIOSH [1994]. Elements: Method 7300 (Supplement Issued 3/15/2003). In: Schlecht PC, O'Connor PF, eds. NIOSH Manual of analytical methods, 4th ed. Cincinnati, OH: U.S. Department of Health and Human Services, Centers for Disease Control and Prevention, National Institute for Occupational Safety and Health, DHHS Publication No. 94-113 [www.cdc.gov/niosh/nmam/].
- [5] Harrison, GR [1969]. Massachusetts Institute of Technology wavelength tables, 2nd ed. West Hanover, MA: Halliday Lithograph, Volume 1.
- [6] ASTM International [2010]. ASTM D7035, Standard test method for the determination of metals and metalloids in airborne particulate matter by inductively coupled plasma atomic emission spectrometry. West Conshohocken, PA: ASTM International [www.astm.org].
- [7] NIOSH [1994]. NIOSH manual of analytical methods (NMAM®). 4th ed. Schlecht PC, O'Connor PF, eds. Cincinnati, OH: U.S. Department of Health and Human Services, Centers for Disease Control and Prevention, National Institute for Occupational Safety and Health, DHHS (NIOSH) Publication No. 94-113 [www.cdc.gov/niosh/nmam/].
- [8] ASTM [1983]. ASTM D1193-77, Standard specification for reagent water. West Conshohocken, PA: ASTM International [www.astm.org].

- [9] Furr KA [1995]. CRC Handbook of Laboratory Safety, 4th ed. Boca Raton, FL: CRC Press.
- [10] NIOSH [1973]. The industrial environment - its evaluation & control. 3rd ed. U.S. Department of Health Education and Welfare, Center for Disease Control, National Institute for Occupational Safety and Health. DHEW (NIOSH) Publication No. 74-117.
- [11] NIOSH [1994]. Particulates not otherwise regulated: Method 0500. In: Eller PM, Cassinelli ME, eds. NIOSH Manual of Analytical Methods, 4th ed. Cincinnati, OH: U.S. Department of Health and Human Services, Centers for Disease Control and Prevention, National Institute for Occupational Safety and Health. DHHS (NIOSH) Publication No. 94-113.
- [12] Stone LC, Perkins JB, Rogers DM [2003]. Backup data report NMAM 7304: Elements by ICP on PVC filters using microwave digestion. Cincinnati OH: DataChem Laboratories, Inc. under NIOSH contract CDC-200-2001-08000. Unpublished.
- [13] Lide DR [1993]. Handbook of chemistry and physics. 74th ed. Boca Raton FL: CRC Press.
- [14] NIOSH pocket guide to chemical hazards. Barsan ME, ed. Cincinnati, OH: US Department of Health and Human Services, Centers for Disease Control and Prevention, National Institute for Occupational Safety and Health, DHHS (NIOSH) Publication No. 2005-149. [www.cdc.gov/niosh/npg].
- [15] Code of Federal Regulations, 29 CFR Part 1910.1000, Table Z-1[2013]. Limits for air standards. National occupational safety and health standards. [https://www.osha.gov/pls/oshaweb/owadisp.show_document?p_table=STANDARDS&p_id=9992] Website accessed on December 13, 2013.

METHOD WRITTEN BY:

David M. Rogers, Lee C. Stone, John M. Reynolds, James B. Perkins, DataChem Laboratories, Salt Lake City, Utah; Yvonne Gagnon, Ronnee Andrews, Ph.D., DART/CEMB.

Disclaimer: Mention of any company or product does not constitute endorsement by NIOSH. In addition, citations to websites external to NIOSH do not constitute NIOSH endorsement of the sponsoring organizations or their programs or products. Furthermore, NIOSH is not responsible for the content of these websites. All web addresses referenced in this document were accessible as of the publication date.

Table 1. PROPERTIES AND SAMPLING VOLUMES

| Element (Symbol) | Properties [13] | | Air Volume, L @ OSHA PEL [4] | |
|-------------------------------|-----------------|--------|------------------------------|--------------------|
| | Atomic Weight | MP, °C | MIN | MAX |
| Aluminum (Al) | 26.98 | 660 | 5 | 100 |
| Arsenic (As) | 74.92 | 817 | 5 | 2000 |
| Barium (Ba) | 137.3 | 727 | 5 ⁽²⁾ | 200 ⁽²⁾ |
| Boron (B) ⁽¹⁾ | 10.81 | 2076 | 5 | 2000 |
| Beryllium(Be) | 9.01 | 1287 | 1250 | 2000 |
| Calcium (Ca) ⁽¹⁾ | 40.08 | 842.5 | 5 | 200 |
| Cadmium (Cd) ⁽³⁾ | 112.40 | 321 | 13 | 2000 |
| Cobalt (Co) | 58.93 | 1495 | 25 | 2000 |
| Chromium (Cr) | 52.00 | 1907 | 5 | 1000 |
| Copper (Cu) | 63.54 | 1083 | 5 | 1000 |
| Iron (Fe) | 55.85 | 1538 | 5 | 100 |
| Potassium (K) ⁽¹⁾ | 39.10 | 64 | 5 | 2000 |
| Lithium (Li) ⁽¹⁾ | 6.94 | 181 | 100 | 2000 |
| Magnesium (Mg) | 24.31 | 651 | 5 | 67 |
| Manganese (Mn) | 54.94 | 1246 | 5 | 200 |
| Molybdenum (Mo) | 95.94 | 2623 | 5 | 67 |
| Sodium (Na) ⁽¹⁾⁽³⁾ | 22.99 | 97.72 | 13 | 2000 |
| Nickel (Ni) | 58.71 | 1455 | 5 | 1000 |
| Phosphorus (P) | 30.97 | 44 | 25 | 2000 |
| Lead (Pb) | 207.19 | 327.2 | 50 | 2000 |
| Platinum (Pt) ⁽³⁾ | 195.1 | 1772.2 | 1250 | 2000 |
| Selenium (Se) | 78.96 | 221 | 13 | 2000 |
| Strontium (Sr) ⁽¹⁾ | 87.62 | 777 | 5 | 2000 |
| Tellurium (Te) | 127.60 | 450 | 25 | 2000 |
| Titanium (Ti) | 47.90 | 1668 | 5 | 100 |
| Thallium (Tl) | 204.37 | 304 | 25 | 2000 |
| Vanadium (V) | 50.94 | 1910 | 5 | 2000 |
| Yttrium (Y) | 88.91 | 1522 | 5 | 1000 |
| Zinc (Zn) | 65.37 | 419 | 5 | 200 |
| Zirconium (Zr) | 91.22 | 1855 | 5 | 200 |

(1) No PEL, REL, or STEL data found [1,14].

(2) Air Volumes Estimated from TWA and LOQ's (see Tables 2, 3). [10]

(3) These metals, as well as tin and antimony, form precipitates in nitric acid when chloride from the PVC filters is present.

Table 2. EXPOSURE LIMITS, CAS #, RTECS [1,14,15]

| Element (Symbol) | CAS # | RTECS # | Exposure Limits, mg/m ³ (C = ceiling limit) | |
|---------------------|------------|-----------|---|---|
| | | | OSHA | NIOSH |
| Aluminum (Al) | 7429-90-5 | BD0330000 | 15 (total dust) 5 (respirable) | 10 (total dust) 5 (respirable, fume) |
| Arsenic (As) | 7440-38-2 | CG0525000 | 0.010 (inorganic) | C 0.002 ⁽¹⁾ |
| Barium (Ba) | 7440-39-3 | CQ8370000 | 0.5 (soluble) | 0.5 (soluble) |
| Beryllium (Be) | 7440-41-7 | DS1750000 | 0.002, C 0.005 | C 0.0005 ⁽¹⁾ |
| Cadmium (Cd) | 7440-43-9 | EU9800000 | 0.005 | lowest feasible conc. ⁽¹⁾ |
| Calcium (Ca) | 7440-70-2 | | No OEL | No OEL |
| Cobalt (Co) | 7440-48-4 | GF8750000 | 0.1 | 0.05 (dust, fume) |
| Chromium (Cr) | 7440-47-3 | GB4200000 | 0.5 (II & III), 0.005 (VI) | 0.5 (II & III), 0.0002 (VI) |
| Cobalt (Co) | 7440-48-4 | GF8750000 | 0.1 | 0.05 (dust, fume) |
| Copper (Cu) | 7440-50-8 | GL5325000 | 1 (dust, mists) 0.1 (fume) | 1 (dust, mists) 0.1 (fume) |
| Iron (Fe) | 7439-89-6 | NO4565500 | 10 (fume) as oxide | 5 (dust, fume) as oxide |
| Magnesium (Mg) | 7439-95-4 | OM2100000 | 15 (dust) as oxide | -- |
| Manganese (Mn) | 7439-96-5 | OO9275000 | C 5 | 1; STEL 3 |
| Molybdenum (Mo) | 7439-98-7 | QA4680000 | 5 (soluble) 15 (total insoluble) | -- |
| Nickel (Ni) | 7440-02-0 | QR5950000 | 1 | 0.015 ⁽¹⁾ |
| Phosphorus (P) | 7723-14-0 | TH3500000 | 0.1 | 0.1 |
| Lead (Pb) | 7439-92-1 | OF7525000 | 0.05 | 0.05 |
| Platinum (Pt) | 7440-06-4 | TP2160000 | 0.002 (soluble) | 1 (metal) |
| Selenium (Se) | 7782-49-2 | VS7700000 | 0.2 | 0.2 |
| Silver (Ag) | 7440-22-4 | VW3500000 | 0.01 (soluble, metal) | 0.01 (soluble, metal) |
| Tellurium (Te) | 13494-80-9 | WY2625000 | 0.1 | 0.1 |
| Titanium (Ti) | 7440-32-6 | XR1700000 | 15 (as TiO ₂) | lowest feasible ⁽¹⁾ |
| Thallium (Tl) | 7440-28-0 | XG3425000 | 0.1 (soluble) | 0.1(soluble) |
| Vanadium (V) | 7440-62-2 | YW1355000 | C 0.5 (respirable) as V ₂ O ₅ C 0.1 (fume) as V ₂ O ₅ | C 0.05 |
| Yttrium (Y) | 7440-65-5 | ZG2980000 | 1 | 1 |
| Zinc (Zn) | 7440-66-6 | ZG8600000 | 5 (ZnO fume) 15 (ZnO dust) 5 (ZnO respirable) | 5; STEL 10 (ZnO fume) 5; C 15 (ZnO dust) |
| Zirconium (Zr) | 7440-67-7 | ZH7070000 | 5 | 5, STEL 10 |

(1) Carcinogen

Table 3. MEASUREMENT WAVELENGTHS AND RECOVERY DATA

| Element ⁽¹⁾ | Wavelength (nm) | LOD (µg/sample) | Lower Level ^(4,5) | | | | Higher Level ⁽⁵⁾ | | | |
|------------------------|-----------------|-----------------|------------------------------|-----|------------------|-----------------------------|-----------------------------|-----|------------------|-----------------------------|
| | | | µg/sample | N = | Percent Recovery | Precision (S _r) | µg/sample | N = | Percent Recovery | Precision (S _r) |
| Ag | 328.07 | 0.1 | 3.00 | 5 | 63.01 | 0.0739 | 300 | 6 | 3.92 | 0.0865 |
| Al | 308.22 | 2 | 50.25 ⁽⁴⁾ | 6 | 89.78 | 0.0565 | 1500 | 6 | 100.71 | 0.0055 |
| Al ⁽²⁾ | 308.214 | 0.5 | 15.0 | 5 | 115.05 | 0.0199 | 1500 | 6 | 105.17 | 0.0056 |
| As | 193.76 | 2 | 15.0 | 5 | 93.29 | 0.0570 | 1500 | 6 | 115.84 | 0.0174 |
| Ba | 493.41 | 0.2 | 1.50 | 5 | 107.16 | 0.0295 | 150 | 6 | 102.22 | 0.0104 |
| B | 249.68 | 0.4 | 7.50 | 5 | 86.38 | 0.0277 | 750 | 6 | 101.19 | 0.0082 |
| Be | 313.04 | 0.008 | 0.152 | 6 | 102.38 | 0.0861 | 15.2 | 6 | 107.71 | 0.0091 |
| Ca | 315.89 | | 151 ⁽⁴⁾ | 6 | 94.64 | 0.0512 | 4500 | 6 | 116.25 | 0.0153 |
| Ca ⁽²⁾ | 315.88 | 2 | 45.0 | 5 | 104.82 | 0.0090 | 4500 | 6 | 98.13 | 0.0066 |
| Cd | 228.80 | 0.2 | 3.00 | 5 | 109.65 | 0.0316 | 300 | 6 | 111.68 | 0.0152 |
| Co | 228.62 | 0.7 | 7.50 | 5 | 89.87 | 0.0338 | 750 | 6 | 114.15 | 0.0141 |
| Cr | 267.72 | 0.7 | 7.50 | 5 | 112.65 | 0.0233 | 750 | 6 | 118.65 | 0.0136 |
| Cr ⁽²⁾ | 267.71 | 0.3 | 7.50 | 5 | 102.60 | 0.0048 | 750 | 6 | 92.98 | 0.0066 |
| Cu | 324.75 | 0.08 | 1.50 | 5 | 106.84 | 0.0364 | 150 | 6 | 100.42 | 0.0058 |
| Cu ⁽²⁾ | 324.75 | 0.08 | 1.50 | 5 | 117.16 | 0.0361 | 150 | 6 | 103.13 | 0.0150 |
| Fe | 259.94 | 15 | 30 | 5 | 120.58 | 0.0405 | 3000 | 6 | 112.41 | 0.0083 |
| Fe ⁽²⁾ | 259.94 | 5 | 30 | 5 | 112.55 | 0.0489 | 3000 | 6 | 97.20 | 0.0085 |
| K | 766.49 | 3 | 100 ⁽⁴⁾ | 6 | 85.57 | 0.0254 | 3000 | 6 | 86.46 | 0.0260 |
| K ⁽²⁾ | 766.49 | | 100 ⁽⁴⁾ | 6 | 99.40 | 0.0300 | 3000 | 6 | 90.02 | 0.0205 |
| Li | 670.78 | 0.06 | 1.50 | 5 | 97.51 | 0.0253 | 150 | 6 | 81.96 | 0.0378 |
| Mg | 279.08 | 0.9 | 15.0 | 5 | 105.25 | 0.0088 | 1500 | 6 | 97.47 | 0.0077 |
| Mg ⁽²⁾ | 279.07 | 0.4 | 15.0 | 5 | 107.33 | 0.0043 | 1500 | 6 | 101.75 | 0.0058 |
| Mn | 257.61 | 0.09 | 1.50 | 5 | 110.24 | 0.0150 | 150 | 6 | 115.56 | 0.0090 |
| Mo | 202.03 | 0.4 | 4.50 | 5 | 87.79 | 0.0433 | 450 | 6 | 120.57 | 0.0093 |
| Mo ⁽²⁾ | 202.029 | 0.3 | 4.50 | 5 | 89.75 | 0.0215 | 450 | 6 | 100.44 | 0.0154 |
| Na | 589.00 | 5 | 75.0 | 6 | 124.56 | 0.0859 | 7500 | 6 | 83.07 | 0.0248 |
| Ni | 231.60 | 0.3 | 4.50 | 5 | 102.93 | 0.0475 | 450 | 6 | 110.59 | 0.0080 |
| Ni ⁽²⁾ | 231.60 | 0.2 | 4.50 | 5 | 109.91 | 0.0047 | 450 | 6 | 101.77 | 0.0139 |
| P | 214.92 | 2 | 30.0 | 5 | 81.82 | 0.0511 | 3000 | 6 | 107.20 | 0.0103 |
| P ⁽²⁾ | 214.91 | 2 | 30.0 | 5 | 86.36 | 0.0077 | 3000 | 6 | 103.33 | 0.0174 |
| Pb | 220.35 | 1 | 15.0 | 5 | 95.85 | 0.0308 | 1500 | 6 | 100.54 | 0.0154 |
| Pt | 203.65 | 9 | 150 | 5 | 104.67 | 0.0182 | 15000 | 6 | 105.19 | 0.0088 |
| Sb ⁽³⁾ | 206.84 | 0.7 | 15.0 | 6 | 25.29 | 0.5861 | 1500 | 6 | 111.95 | 0.0086 |

(1) Values reported were obtained with a Fisons ARL Accuris ICP-AES unless otherwise noted; performance may vary with instrument and should be independently verified.

(2) Values reported were obtained with a Perkin Elmer Optima 3000 DV ICP-AES.

(3) Elements that were evaluated and found not suitable for analysis by this method.

(4) Values given (lower level) are for the 10xLOQ level due to low recoveries at the 3xLOQ level.

(5) LOQ = Estimated limit of quantitation

Table 3. MEASUREMENT WAVELENGTHS AND RECOVERY DATA

| Element ⁽¹⁾ | Wavelength (nm) | LOD (µg/sample) | Lower Level ^(4,5) | | | | Higher Level ⁽⁵⁾ | | | |
|------------------------|-----------------|-----------------|------------------------------|-----|------------------|-----------------------------|-----------------------------|-----|------------------|-----------------------------|
| | | | µg/sample | N = | Percent Recovery | Precision (S _r) | µg/sample | N = | Percent Recovery | Precision (S _r) |
| Se | 196.09 | 5 | 75.0 | 5 | 102.05 | 0.0531 | 7500 | 6 | 111.35 | 0.0063 |
| Se ⁽²⁾ | 196.02 | 2 | 75.0 | 5 | 99.93 | 0.0051 | 7500 | 6 | 99.72 | 0.0082 |
| Sn | 189.9 | | 75.0 | 5 | 30.82 | 0.0502 | 7500 | 6 | 79.56 | 0.0124 |
| Sn ^(2,3) | 189.9 | 0.4 | 75.0 | 5 | 37.87 | 0.0816 | 7500 | 6 | 92.34 | 0.0129 |
| Sr | 421.55 | 0.04 | 7.50 | 5 | 100.00 | 0.0049 | 750 | 6 | 99.54 | 0.0055 |
| Te | 214.27 | 4 | 30.0 | 5 | 95.80 | 0.0624 | 3000 | 6 | 110.81 | 0.0094 |
| Te ⁽²⁾ | 214.28 | 2 | 30.0 | 5 | 97.18 | 0.0100 | 3000 | 6 | 99.64 | 0.0074 |
| Ti | 337.28 | 0.2 | 3.00 | 5 | 81.66 | 0.0392 | 300 | 6 | 103.42 | 0.0101 |
| Ti ⁽³⁾ | 334.94 | 0.1 | 3.00 | 5 | 82.68 | 0.0374 | 300 | 6 | 96.13 | 0.0121 |
| Tl | 190.86 | 2 | 15.0 | 5 | 96.38 | 0.0605 | 1500 | 6 | 97.25 | 0.0148 |
| Tl ⁽³⁾ | 190.79 | 1 | 15.0 | 5 | 97.75 | 0.0032 | 1500 | 6 | 92.04 | 0.0119 |
| V | 292.40 | 0.1 | 1.50 | 5 | 104.54 | 0.0528 | 150 | 6 | 111.15 | 0.0160 |
| V ⁽²⁾ | 292.40 | 0.09 | 1.50 | 5 | 100.99 | 0.0146 | 150 | 6 | 99.38 | 0.0232 |
| Y | 371.03 | 0.07 | 0.752 | 5 | 105.98 | 0.0245 | 75.2 | 6 | 105.03 | 0.0073 |
| Zn | 213.85 | 0.2 | 3.00 | 5 | 110.76 | 0.0327 | 300 | 6 | 116.84 | 0.0153 |
| Zn ⁽²⁾ | 213.86 | 0.4 | 3.00 | 5 | 93.45 | 0.0351 | 300 | 6 | 94.01 | 0.0055 |
| Zr | 339.20 | 0.2 | 1.50 | 5 | 102.61 | 0.0242 | 150 | 6 | 101.56 | 0.0144 |

(1) Values reported were obtained with a Fisons ARL Accuris ICP-AES unless otherwise noted; performance may vary with instrument and should be independently verified.

(2) Values reported were obtained with a Perkin Elmer Optima 3000 DV ICP-AES.

(3) Elements that were evaluated and found not suitable for analysis by this method.

(4) Values given (lower level) are for the 10xLOQ level due to low recoveries at the 3xLOQ level.

(5) LOQ = Estimated limit of quantitation

Table 4. OVERALL PRECISION AND ACCURACY DATA [13]

| Element | Instrument ⁽¹⁾ | Range Studied (µg/sample) | | Bias | Range of Bias | | Precision S _{rT} | Accuracy (%) | Lowest Level ⁽²⁾ |
|------------|---------------------------|------------------------------|-------|--|---------------|---------|------------------------------|-----------------|--------------------------------|
| | | From | To | | From | To | | | |
| Aluminum | Fisons | 5.025 | 1500 | -0.0318 | -0.1022 | 0.0240 | 0.0419 | 9.9 | 50.25 |
| Aluminum | P-E Optima | 5.025 | 1500 | 0.0833 | 0.0567 | 0.1505 | 0.0379 | 15.1 | 15 |
| Antimony | Fisons | 5.025 | 1500 | Poor and variable recoveries across study range. | | | | | |
| Arsenic | Fisons | 5.025 | 1500 | 0.0630 | -0.0671 | 0.1584 | 0.0461 | 14.3 | 15 |
| Barium | Fisons | 0.5038 | 150.4 | 0.0433 | 0.0222 | 0.0716 | 0.0182 | 7.6 | 0.5 |
| Beryllium | Fisons | 0.0509 | 15.2 | 0.0652 | 0.0366 | 0.0980 | 0.0163 | 9.5 | 0.0509 |
| Boron | Fisons | 2.514 | 750.4 | -0.0387 | -0.1362 | 0.0118 | 0.0164 | 6.4 | 7.504 |
| Cadmium | Fisons | 1.005 | 300.0 | 0.0923 | 0.0718 | 0.1167 | 0.0307 | 14.8 | 1.005 |
| Calcium | Fisons | 15.08 | 4500 | 0.0779 | -0.0536 | 0.1624 | 0.0313 | 13.4 | 150.75 |
| Calcium | P-E Optima | 15.08 | 4500 | 0.0453 | 0.0098 | 0.0963 | 0.0245 | 8.8 | 15.08 |
| Chromium | Fisons | 2.514 | 750.4 | 0.1395 | 0.0974 | 0.1865 | 0.0214 | 18 | 2.514 |
| Chromium | P-E Optima | 2.514 | 750.4 | -0.0018 | -0.0701 | 0.1245 | 0.0131 | <5 | 2.514 |
| Cobalt | Fisons | 2.514 | 750.4 | 0.0592 | -0.1013 | 0.1508 | 0.0264 | 10.4 | 7.504 |
| Copper | Fisons | 0.5038 | 150.4 | 0.0475 | 0.0272 | 0.0684 | 0.0240 | 8.9 | 0.5038 |
| Copper | P-E Optima | 0.5038 | 150.4 | 0.0829 | 0.0313 | 0.1716 | 0.0217 | 12.1 | 1.504 |
| Iron | Fisons | 10.05 | 3000 | 0.1101 | 0.0630 | 0.2057 | 0.0397 | 18.6 | 30 |
| Iron | Fisons | 10.05 | 3000 | 0.0836 | 0.0630 | 0.0974 | 0.0396 | 15.4 | 100.5 |
| Iron | P-E Optima | 10.05 | 3000 | 0.0445 | -0.0205 | 0.1255 | 0.0404 | 11.4 | 30 |
| Lead | Fisons | 5.025 | 1500 | -0.0241 | -0.0668 | 0.0124 | 0.0279 | 6.9 | 5.025 |
| Lithium | Fisons | 0.5038 | 150.4 | -0.0690 | -0.1804 | 0.0132 | 0.0276 | 11.1 | 0.5038 |
| Magnesium | Fisons | 5.025 | 1500 | 0.0156 | -0.0253 | 0.0524 | 0.0171 | <5 | 5.025 |
| Magnesium | P-E Optima | 5.025 | 1500 | 0.0715 | 0.0421 | 0.1372 | 0.0249 | 11.5 | 5.025 |
| Manganese | Fisons | 0.5038 | 150.4 | 0.1357 | 0.1005 | 0.1755 | 0.0201 | 17.3 | 0.5038 |
| | Fisons | 1.509 | 450.4 | -0.0388 | -0.1597 | 0.1353 | 0.0795 | 16.7 | 1.509 |
| | P-E Optima | 1.509 | 450.4 | -0.0489 | -0.2033 | 0.0969 | 0.0179 | 7.7 | 1.509 |
| Nickel | Fisons | 1.509 | 450.4 | 0.0787 | 0.0293 | 0.1274 | 0.0338 | 13.8 | 4.504 |
| Nickel | P-E Optima | 1.509 | 450.4 | 0.0645 | 0.0177 | 0.1406 | 0.0159 | 9.2 | 1.509 |
| Phosphorus | Fisons | 10.05 | 3000 | -0.0546 | -0.1818 | 0.0011 | 0.0417 | 12 | 30 |
| Phosphorus | P-E Optima | 10.05 | 3000 | -0.0163 | -0.1364 | 0.0333 | 0.0124 | <5 | 10.05 |
| Platinum | Fisons | 50 | 15000 | 0.0423 | 0.0097 | 0.0671 | 0.0226 | 8.2 | 150 |
| Potassium | Fisons | 10.05 | 3000 | -0.0909 | -0.1443 | -0.0316 | 0.0265 | 13.1 | 100.5 |
| Potassium | P-E Optima | 10.05 | 3000 | -0.0499 | -0.0998 | -0.0060 | 0.0249 | 8.8 | 100.5 |
| Selenium | Fisons | 25.12 | 7500 | 0.0941 | 0.0675 | 0.1150 | 0.0150 | 12.1 | 25.12 |
| Selenium | P-E Optima | 25.12 | 7500 | 0.0026 | -0.0027 | 0.0115 | 0.0127 | <5 | 25.12 |
| Silver | Fisons | 1.005 | 300 | Poor and variable recoveries across study range. | | | | | |
| Sodium | Fisons | 25.12 | 7500 | -0.0492 | -0.1694 | 0.0718 | 0.0246 | 8.8 | 251.2 |
| Strontium | Fisons | 2.514 | 750.4 | 0.0172 | -0.00002 | 0.0373 | 0.0153 | <5 | 2.514 |
| Tellurium | Fisons | 10.05 | 3000 | 0.0295 | -0.0420 | 0.1037 | 0.0404 | 9.8 | 30 |

(1) Values reported were obtained with a Fisons ARL Accuris ICP-AES or a Perkin Elmer Optima 3000 DV ICP-AES.

(2) Lowest level in range studied at which recoveries were between 81 and 121% recovery and relative standard deviation (S_r) less than 0.1100 on 5 or 6 replicates. Performance may vary with instrument and should be independently verified.

Table 4. OVERALL PRECISION AND ACCURACY DATA [13]

| Element | Instrument ⁽¹⁾ | Range Studied (µg/sample) | | Bias | Range of Bias | | Precision S _{rT} | Accuracy (%) | Lowest Level ⁽²⁾ |
|-----------|---------------------------|------------------------------|-------|--|---------------|---------|------------------------------|-----------------|--------------------------------|
| | | From | To | | From | To | | | |
| Tellurium | P-E Optima | 10.05 | 3000 | -0.0043 | -0.0282 | 0.0163 | 0.0155 | <5 | 10.05 |
| Thallium | Fisons | 5.025 | 1500 | -0.0081 | -0.0362 | 0.0334 | 0.0407 | 8.2 | 15 |
| Thallium | P-E Optima | 5.025 | 1500 | -0.0505 | -0.0688 | -0.0048 | 0.0250 | 9 | 5.025 |
| Tin | Fisons | 25.12 | 7500 | Poor and variable recoveries across study range. | | | | | |
| Tin | P-E Optima | 25.12 | 7500 | Poor and variable recoveries across study range. | | | | | |
| Titanium | Fisons | 1.005 | 300 | -0.0827 | -0.1834 | 0.0342 | 0.0269 | 12.3 | 3 |
| Titanium | P-E Optima | 1.005 | 300 | -0.1072 | -0.1732 | -0.0387 | 0.0321 | 15.3 | 1.005 |
| Vanadium | Fisons | 0.5038 | 150.4 | 0.0704 | 0.0438 | 0.1114 | 0.0195 | 10.5 | 0.5038 |
| Vanadium | P-E Optima | 0.5038 | 150.4 | -0.0063 | -0.0217 | 0.0099 | 0.0198 | <5 | 0.5038 |
| Yttrium | Fisons | 0.2519 | 75.2 | 0.0598 | 0.0466 | 0.0795 | 0.0164 | 8.9 | 0.2519 |
| Zinc | Fisons | 1.005 | 300 | 0.1452 | 0.0630 | 0.2976 | 0.0340 | 22 | 1.005 |
| Zinc | Fisons | 1.005 | 300 | 0.1190 | 0.0630 | 0.1683 | 0.0356 | 18.7 | 3 |
| Zinc | P-E Optima | 1.005 | 300 | -0.0502 | -0.0655 | -0.0388 | 0.0295 | 9.6 | 3 |
| Zirconium | Fisons | 0.5025 | 150 | 0.0164 | -0.0096 | 0.0350 | 0.0175 | <5 | 0.5025 |

(1) Values reported were obtained with a Fisons ARL Accuris ICP-AES or a Perkin Elmer Optima 3000 DV ICP-AES.

(2) Lowest level in range studied at which recoveries were between 81 and 121% recovery and relative standard deviation (S_r) less than 0.1100 on 5 or 6 replicates. Performance may vary with instrument and should be independently verified.

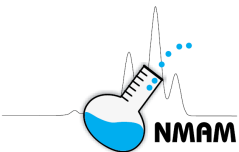

AW: Table 1

CAS: Table 2

RTECS: Table 2

METHOD: 7306, Issue 1

EVALUATION: FULL

Issue 1: 10 September 2015

OSHA PELs: Table 2
 NIOSH RELs: Table 2
 OTHER OELs: [1,2]

PROPERTIES: Table 1

| | | | | | | | |
|------------------|-----------|----------|-----------|------------|-----------|-----------|-----------|
| ELEMENTS: | aluminum | cadmium | indium | magnesium | potassium | tellurium | yttrium |
| | antimony | calcium | iron | manganese | selenium | thallium | zirconium |
| | arsenic | chromium | lanthanum | molybdenum | silver | titanium | zinc |
| | barium | cobalt | lead | nickel | strontium | tungsten | |
| | beryllium | copper | lithium | phosphorus | tin | vanadium | |

SAMPLING

MEASUREMENT

SAMPLER: Internal capsule, cellulose acetate dome with inlet opening, attached to 0.8-µm pore size mixed cellulose ester (MCE) membrane filter and housed within a 2-piece, closed-face cassette (CFC) filter holder, 37-mm diameter

FLOWRATE: 1 to 4 L/min

VOL-MIN: Table 1
-MAX: Table 1

SHIPMENT: Routine

SAMPLE STABILITY: Stable

BLANKS: Minimum of 2 field blanks per set

TECHNIQUE: INDUCTIVELY COUPLED PLASMA – ATOMIC EMISSION SPECTROMETRY (ICP-AES)

ANALYTES: Elements above

SAMPLE DISSOLUTION: Hotplate digestion (NIOSH 7300 or 7301), microwave digestion (NIOSH 7302) or hot block extraction (NIOSH 7303)

SOLUTION: Dependent upon sample preparation method

WAVELENGTH: Depends upon element; See Table 3

BACKGROUND CORRECTION: Spectral wavelength shift

CALIBRATION: Elements in acid matrix-matched to the sample; varies depending on sample preparation method

RANGE: Varies with element

ESTIMATED LOD: Table 3

PRECISION (\bar{S}_r): Table 4

ACCURACY

RANGES STUDIED: Tables 3 and 4

BIAS: Table 4

OVERALL PRECISION (\bar{S}_{rt}) Table 4

ACCURACY: Table 4

APPLICABILITY: The working range of this method is 4×10^{-5} mg/m³ to 10 mg/m³ for each element in a 500-L air sample. This is simultaneous elemental analysis, not compound specific. Verify that the types of compounds in the samples are soluble with the dissolution procedure selected. Some compounds of these elements require special sample treatment.

INTERFERENCES: Spectral interferences are the primary interferences encountered in ICP-AES analysis. These are minimized by judicious wavelength selection, interelement correction factors and background correction [3,4].

OTHER METHODS: The internal capsule sampler used in this method is a recommended alternative to filter-only sampling [5] of NIOSH methods 7300 [6], 7301 [7], 7302 [8] and 7303 [9]. Use of an internal capsule sampler is an efficient means to account for sampler wall deposits that would otherwise be excluded by filter-only sampling. Unless other means are used to account for non-filter deposits inside the cassettes (e.g. within-cassette extraction, rinsing or wiping), internal capsule samplers should be used. OSHA method ID-125G [10] describes ICP-AES multielement analysis after hotplate digestion using nitric acid, sulfuric acid and hydrogen peroxide. ASTM D7035 [11] and ISO 15202 [12] are related voluntary consensus standard ICP-AES methods for multielement sampling and analysis of workplace atmospheres.

REAGENTS:

1. Nitric acid (HNO₃)*, concentrated, Trace metal grade
2. Hydrochloric acid (HCl)*, conc., Trace metal grade (only required if hydrochloric acid digestion is to be carried out)
3. Perchloric acid (HClO₄)*, conc., optima (only required if perchloric acid digestion is to be carried out)
4. Calibration stock solutions, 1000 µg/L: Commercially available; or prepared per instrument manufacturer's recommendation
5. Dilution acid: 20% nitric acid* (7302); 4% nitric acid:1% perchloric acid* (7300); 5% aqua regia (7301)*; or 5% nitric acid: 5% hydrochloric acid* (7303) [dilution acid is dependent upon sample preparation method used]
6. Argon, as specified by ICP-AES manufacturer
7. Deionized water, ASTM Type II [13] or equivalent

* See SPECIAL PRECAUTIONS

EQUIPMENT:

1. Sampler: cellulose acetate internal capsule attached to mixed cellulose ester membrane filter, 0.8-µm pore size; 37-mm diameter, in 2-piece, closed-face cassette filter holder
2. Personal sampling pump, 1 to 4 L/min, with flexible connecting tubing, capable of maintaining constant flow
3. Inductively coupled plasma-atomic emission spectrometer, equipped as specified by the manufacturer for analysis of elements of interest
4. Regulator, two-stage, for argon
5. Beakers, Phillips, 125-mL, or Griffin, 50-mL, with watch glass covers**
6. Volumetric flasks, 10-, 25-, 100-mL, and 1-L**
7. Assorted volumetric pipets, as needed**
8. Forceps, plastic or plastic-tipped
9. Hotplate (NIOSH 7300 or 7301), microwave oven (NIOSH 7302) or hot block (NIOSH 7303) [6-9].
10. Centrifuge tubes, 50-mL or sized appropriately for hot block apparatus.

** Clean all glassware with conc. nitric acid and rinse thoroughly in deionized water before use

SPECIAL PRECAUTIONS: All perchloric acid digestions must be carried out in a perchloric acid fume hood. When working with concentrated acids, wear protective clothing, safety goggles and gloves. All work should be performed with adequate ventilation for personnel and equipment. It is imperative that acid be added to water in order to avoid a violent exothermic reaction.

SAMPLING:

1. Calibrate each personal sampling pump with a representative sampler in line.
NOTE: See NMAM guidance chapters for discussion on sampling.
2. Sample at an accurately known flow rate between 1 and 4 L/min (± 5%) for a total sample size of <1 to 2000 L (see Table 1) for TWA measurements. Do not exceed a sampler loading of approximately 5 mg total dust.
NOTE: Filter overloading can be assessed by periodic visual checks. See NMAM guidance chapters for additional discussion on filter capacity.

SAMPLE PREPARATION:

3. Open the cassette filter holders and, using nonmetal forceps, transfer the samples and blanks to clean digestion vessels.
NOTE: Samples may not easily fit into the digestion vessels. Care must be taken to ensure no sample is lost during the placement of the samples in the digestion vessels.

4. Carry out sample dissolution in accordance with one of the sample preparation procedures described in NIOSH 7300, 7301, 7302, or 7303 [6-9].
NOTE: The dissolution acid level within the vessel should cover the internal capsule.
5. After allowing to cool to room temperature, transfer the solutions quantitatively to 25-mL volumetric flasks.
6. Dilute to volume.
NOTE: If greater sensitivity is required, the final sample volume may be held to 10 mL.

CALIBRATION AND QUALITY CONTROL:

7. Calibrate the spectrometer according to the manufacturer recommendations.
NOTE: Typically, an acid blank and 1.0 µg/mL multielement calibration standards are used. The following multielement combinations are chemically compatible in 5% HNO₃:
 - a. Al, As, Ba, Be, Ca, Cd, Co, Cr, Cu, Fe, La, In, Na
 - b. Ag, K, Li, Mg, Mn, Ni, P, Pb, Se, Sr, Tl, V, Y, Zn, Sc
 - c. Mo, Sb, Sn, Te, Ti, W, Zr
8. Analyze at least one calibration standard per ten samples.
9. Check recoveries with at least one media blank and two spiked media blanks per twenty samples. Media should be spiked with analytes of interest.
NOTE: Whenever possible, QA/QC samples should be prepared from certified reference materials in a matrix similar to the bulk material sampled. Liquid spiked filters are only surrogates for real world samples and QC data based upon certified samples are preferred.

MEASUREMENT:

10. Set ICP-AES spectrometer to conditions specified by manufacturer.
11. Analyze standards and samples by ICP-AES in accordance with manufacturer recommendations.
NOTE: If the values for the samples are above the range of the standards, dilute the solutions (ensuring the samples remain acid matrix-matched to the calibration standards), reanalyze and apply the appropriate dilution factor in the calculations.

CALCULATIONS:

12. Obtain the solution concentrations for the sample, C_s (µg/mL), and the average media blank, C_b (µg/mL), from the instrument.
13. Using the solution volumes of sample, V_s (mL), and media blank, V_b (mL), calculate the concentration, C (mg/m³), of each element in the air volume sampled, V (L):

$$C = \frac{(C_s V_s) - (C_b V_b)}{V}, \text{ mg/m}^3$$

NOTE: µg/L is approximately equal to mg/m³

EVALUATION OF METHOD:

A previous interlaboratory investigation of aerosol-loaded cellulosic capsules (provided by SKC, Inc., Eighty-Four, PA) provided the background information for the development of this method [14]. That investigation yielded data for Cd, Cr, Co, Cu, Fe, Mn, Ni and Pb [14]. Recoveries for these elements were quantitative and values of overall relative standard deviation were <0.20 [14], which compare favorably with the variability typically observed in interlaboratory multielement analysis of air samples [15,16].

To obtain performance data for additional elements, interlaboratory performance data were obtained using 37-mm diameter cellulose acetate internal capsules attached to mixed-cellulose ester filters (Solu-sert™ from

Zefon International, Ocala, FL). Solu-sert™ capsules were dosed with 33 elements at three different spiking levels (spike levels certified by High-Purity Standards, North Charleston, SC), listed in Table 3. Sets of the spiked samples were conveyed to participating volunteer laboratories and analyzed by ICP-AES after sample dissolution. A variety of sample preparation procedures were used by the labs including NIOSH 7300, 7301, 7302, 7303, hot plate digestion utilizing nitric acid, sulfuric acid and hydrogen peroxide (modified NIOSH 7300), and microwave assisted digestion using nitric acid and hydrogen peroxide (modified NIOSH 7302). Results were received from 9 laboratories; however, not every spiked element was reported by each laboratory. Individual sample results may be found in the backup data report [17]. Statistical calculations were performed using SAS Software (version 9.2, SAS Institute Inc., Cary, NC). For each data subset, Grubbs' test at 1% confidence level was used to identify outliers, which if identified, were removed prior to further statistical calculations. No statistically significant differences were found between the laboratory results for the spiked samples; therefore, all reported data (regardless of the sample preparation method) are included in Tables 3 & 4. Recoveries were quantitative (as defined in Kennedy, et al. [18]) and interlaboratory variability was <0.20 for most elements and loading levels (Table 3). Mean overall recoveries below 90% were found only for Cr, K, and W at low loadings and for Ag at medium and high spike levels and for In at the high spike level. RSD values > 0.20 were found only for Sn at the low spike level, Ag at medium and high spike levels, and In and K at all loadings. Results for precision, bias and accuracy are summarized in Table 4.

With the domed top, the internal capsule can be difficult to fit into standard sample digestion vessels. One way to achieve this is to place the samplers into the vessels by bending them slightly inward (using coated forceps) and to push them into the bottom of the vessel to ensure they are covered with the digestion acids. Care must be taken to ensure that sample is not lost in this process. Additional guidance is available from the internal capsule manufacturer [19].

While no statistically significant differences were found based upon the sample preparation, it is important to note that interlaboratory variation is included in those calculations. Some differences in the sample preparation methods may have been statistically significant without that variability. Of particular importance are the less than quantitative recoveries for Sb, Sn, and Ti using NIOSH 7300. This sample preparation (as written) may not be amenable to the analysis of those elements. While this method lists several options for sample preparation, it is imperative that the suitability of the particular sample preparation method for the analytes of interest be considered.

Appreciable (>0.5 µg) media background levels were reported by Certified Reference Material (CRM) provider and/or the participating laboratories for several elements, notably Al, Ca, Cr, Fe, In, K, Mg, P, Sb, Se, and Tl. Trace media background levels of a few other elements, i.e., Ba, Cu and Zn, were also obtained. This background was effectively corrected for, as evidenced by the quantitative recoveries obtained for the vast majority of the elements and loading levels. Where the background levels may pose a greater influence is in the calculation of the method LOD. Method LODs (calculated using the standard deviation of blank responses) for internal capsule samples were greater than those calculated for MCE filters alone for many of the elements [17]. Care should be taken in choosing the appropriate media in concert with the expected sample concentrations.

REFERENCES:

- [1] ACGIH [2014]. TLVs and BEIs based on the documentation of the Threshold Limit Values for chemical substances and physical agents and biological exposure indices. Cincinnati, Ohio: American Conference of Governmental Industrial Hygienists [www.acgih.org]. Date accessed May 2015.
- [2] Institut für Arbeitsschutz der Deutschen Gesetzlichen Unfallversicherung [2013]. GESTIS database on hazardous substances (German Social Accident Insurance). Sankt Augustin, FRG: [http://www.dguv.de/ifa/GESTIS]. Date accessed May 2015.

- [3] Dean JA [1995]. Atomic spectroscopy. In: Analytical Chemistry Handbook; Section 7. New York, NY: McGraw-Hill.
- [4] Montaser A, Golightly DW, eds. [1992]. Inductively coupled plasmas in analytical atomic spectrometry. 2nd ed. Hoboken, NJ: John Wiley & Sons, Inc.
- [5] Ashley K, Harper M [2013]. Closed-face filter cassette (CFC) sampling – Guidance on procedures for inclusion of material adhering to internal sampler surfaces. *J Occup Environ Hyg* 10:D29-D33.
- [6] NIOSH [1994]. Elements by ICP (Nitric/Perchloric Acid Ashing): Method 7300. In: Schlecht PC, O'Connor PF, eds. NIOSH manual of analytical methods. 4th ed. Cincinnati, OH: U.S. Department of Health and Human Services, Centers for Disease Control and Prevention, National Institute for Occupational Safety and Health, DHHS (NIOSH) Publication No. 94-113 [www.cdc.gov/niosh/nmam/].
- [7] NIOSH [1994]. Elements by ICP: Method 7301. In: Schlecht PC, O'Connor PF, eds. NIOSH manual of analytical methods. 4th ed. Cincinnati, OH: U.S. Department of Health and Human Services, Centers for Disease Control and Prevention, National Institute for Occupational Safety and Health, DHHS (NIOSH) Publication No. 94-113 [www.cdc.gov/niosh/nmam/].
- [8] NIOSH [2014]. Elements by ICP (Microwave Digestion): Method 7302. In: Ashley K, O'Connor PF, eds. NIOSH manual of analytical methods. 5th ed. Cincinnati, OH: U.S. Department of Health and Human Services, Centers for Disease Control and Prevention, National Institute for Occupational Safety and Health, DHHS (NIOSH) Publication No. 2014-151 [www.cdc.gov/niosh/nmam/].
- [9] NIOSH [1994]. Elements by ICP (Hot Block/HCl/HNO₃ Digestion): Method 7303. In: Schlecht PC, O'Connor PF, eds. NIOSH manual of analytical methods. 4th ed. Cincinnati, OH: U.S. Department of Health and Human Services, Centers for Disease Control and Prevention, National Institute for Occupational Safety and Health, DHHS (NIOSH) Publication No. 94-113 [www.cdc.gov/niosh/nmam/].
- [10] OSHA [2002]. Metal and metalloid particulates in workplace atmospheres (ICP analysis). In: OSHA Sampling and Analytical Methods. Sandy, UT: Occupational Safety and Health Administration.
- [11] ASTM International [2010]. ASTM D7035, Standard test method for the determination of metals and metalloids in workplace air by inductively coupled plasma atomic emission spectrometry. West Conshohocken, PA: ASTM International.
- [12] ISO [2011]. ISO 15202, Workplace air – Determination of metals and metalloids in airborne particulate matter by inductively coupled plasma atomic emission spectrometry (3 parts). Geneva, Switzerland: International Organization for Standardization.
- [13] ASTM [2011]. ASTM D1193, Standard specification for reagent water. West Conshohocken, PA: ASTM International.
- [14] Harper M, Ashley K [2013]. Acid-soluble internal capsules for closed-face cassette elemental sampling and analysis of workplace air. *J Occup Environ Hyg* 10:297-306.
- [15] Ashley K, Shulman SA, Brisson MJ, Howe AM [2012]. Interlaboratory evaluation of trace element determination in workplace air samples by inductively coupled plasma mass spectrometry. *J Environ Monit* 14:360-367.
- [16] Stacey P, Butler OT [2008]. Performance of laboratories analysing welding fume on filter samples – Results from the WASP Proficiency Testing Scheme. *Ann Occup Hyg* 52:287-295.
- [17] Ashley K, Andrews RN, Feng HA [2014]. Elements by cellulosic internal sampler and ICP-AES, NIOSH 7306, Backup Data Report. Cincinnati, OH, Unpublished.
- [18] NIOSH [1995]. Guidelines for air sampling and analytical method development and evaluation. By Kennedy ER, Fischbach TJ, Song R, Eller PM, Shulman SA. Cincinnati, OH: U.S. Department of Health and Human Services, Centers for Disease Control and Prevention, National Institute for Occupational Safety and Health, DHHS (NIOSH) Publication No. 95-117.
- [19] Zefon International. Operating instructions Solu-Sert™ soluble filter capsule. Ocala, FL: Zefon International. [https://www.zefon.com/Content/Products/SamplingMedia/Solu-Sert_IFU.pdf] Date accessed: May 2015.

- [20] NIOSH [1994]. Measurement uncertainty and NIOSH method accuracy: Chapter P. In: Schlecht PC, O'Connor PF, eds. NIOSH manual of analytical methods. 4th ed. Cincinnati, OH: U.S. Department of Health and Human Services, Centers for Disease Control and Prevention, National Institute for Occupational Safety and Health, DHHS (NIOSH) Publication No. 94-113 [www.cdc.gov/niosh/nmam/].
- [21] Lide DR [2014]. Handbook of Chemistry and Physics, 94th ed. Boca Raton: FL, CRC Press
- [22] NIOSH [2005]. NIOSH pocket guide to chemical hazards. Barsan ME, ed. Cincinnati, OH: US Department of Health and Human Services, Centers for Disease Control and Prevention, National Institute for Occupational Safety and Health, DHHS (NIOSH) Publication No. 2005-149. [www.cdc.gov/niosh/npg/].

METHOD WRITTEN BY:

Kevin Ashley, Ph.D., Ronnee N. Andrews, Ph.D., and H. Amy Feng, NIOSH/DART.

Disclaimer: Mention of any company or product does not constitute endorsement by NIOSH. In addition, citations to websites external to NIOSH do not constitute NIOSH endorsement of the sponsoring organizations or their programs or products. Furthermore, NIOSH is not responsible for the content of these websites. All web addresses referenced in this document were accessible as of the publication date.

| TABLE 1. PROPERTIES AND SAMPLING VOLUMES [21] | | | | |
|--|---------------------------|---------------|---|------------------------|
| Element (Symbol) | Atomic Weight (AW) | MP, °C | Volume, L @ OSHA PEL^A | |
| | | | MIN^B | MAX^C |
| Silver (Ag) | 107.87 | 961 | 6 | >2000 ^D |
| Aluminum (Al) | 26.98 | 660 | <1 | 330 |
| Arsenic (As) | 74.92 | 817 | 32 | >2000 |
| Barium (Ba) | 137.34 | 727 | 3 | >2000 |
| Beryllium (Be) | 9.01 | 1287 | 10 | >2000 |
| Calcium (Ca) | 40.08 | 842 | -- | -- |
| Cadmium (Cd) | 112.41 | 321 | 3 | >2000 |
| Cobalt (Co) | 58.93 | 1495 | <1 | >2000 |
| Chromium (Cr) | 52.00 | 1907 | 1 | >2000 |
| Copper (Cu) | 63.54 | 1083 | <1 | >2000 |
| Iron (Fe) | 55.85 | 1538 | 2 | 500 |
| Indium (In) | 114.82 | 156 | 8 | >2000 |
| Potassium (K) | 39.10 | 64 | -- | -- |
| Lanthanum (La) | 138.91 | 920 | -- | -- |
| Lithium (Li) | 6.94 | 181 | -- | -- |
| Magnesium (Mg) | 24.31 | 651 | <1 | 330 |
| Manganese (Mn) | 54.94 | 1246 | <1 | 1000 |
| Molybdenum (Mo) | 95.94 | 2623 | <1 | 330 |
| Nickel (Ni) | 58.71 | 1455 | 2 | >2000 |
| Phosphorus (P) | 30.97 | 44 | 9 | >2000 |
| Lead (Pb) | 207.19 | 328 | 4 | >2000 |
| Antimony (Sb) | 121.75 | 631 | 1 | >2000 |
| Selenium (Se) | 78.96 | 221 | 2 | >2000 |
| Tin (Sn) | 118.69 | 232 | <1 | >2000 |
| Strontium (Sr) | 87.62 | 777 | -- | -- |
| Tellurium (Te) | 127.60 | 450 | 7 | >2000 |
| Titanium (Ti) | 47.87 | 1668 | -- | -- |
| Thallium (Tl) | 204.37 | 304 | 1 | >2000 |
| Vanadium (V) | 50.94 | 1910 | -- | -- |
| Tungsten (W) | 183.85 | 3422 | -- | -- |
| Yttrium (Y) | 88.91 | 1522 | <1 | >2000 |
| Zinc (Zn) | 65.37 | 419 | -- | -- |
| Zirconium (Zr) | 91.22 | 1855 | <1 | 1000 |

^A Exposure limits listed in Table 2.
^B Min calculated using the method quantitation limits following NIOSH 7302 sample preparation.
^C Max calculated using 5 mg of sample collected.
^D Indicates that the calculated maximum volume is greater than the volume collected at the maximum flow rate (4 L/min) of the method for an 8-hour shift.

| TABLE 2. EXPOSURE LIMITS, CAS#, RTECS [22] | | | | |
|--|------------|-----------|---|--|
| Element (Symbol) | CAS # | RTECS # | Exposure Limits | |
| | | | OSHA PEL (mg/m ³) | NIOSH REL (mg/m ³) |
| Silver (Ag) | 7440-22-4 | VW3500000 | 0.01 (dust, fume, metal) | 0.01 (metal, soluble) |
| Aluminum (Al) | 7429-90-5 | BD0330000 | 15 (total dust) 5 (respirable) | 10 (total dust) 5 (respirable fume) 2 (soluble) |
| Arsenic (As) | 7440-38-2 | CG0525000 | 0.010 | C ^E 0.002 (15 min), Ca ^F 0.5 |
| Barium (Ba) | 7440-39-3 | CQ8370000 | 0.5 | |
| Beryllium (Be) | 7440-41-7 | DS1750000 | 0.002, C 0.005 | C 0.0005, Ca |
| Calcium (Ca) | 7440-70-2 | -- | -- | -- |
| Cadmium (Cd) | 7440-43-9 | EU9800000 | 0.005 | lowest feasible, Ca |
| Cobalt (Co) | 7440-48-4 | GF8750000 | 0.1 (dust, fume) | 0.05 (dust, fume) |
| Chromium (Cr) | 7440-47-3 | GB4200000 | 1 (metals, insoluble salts) 0.5 (Cr II & Cr III) | 0.5 |
| Copper (Cu) | 7440-50-8 | GL5325000 | 1 (dust, mists) 0.1 (fume) | 1 (dust, mists) 0.1 (fume) |
| Iron (Fe) | 7439-89-6 | NO4565500 | 10 (fume) as oxide | 5 (dust, fume) oxide as Fe |
| Indium (In) | 7440-74-6 | NL1050000 | 0.1 | 0.1 |
| Potassium (K) | 7440-09-7 | TS6460000 | -- | -- |
| Lanthanum | 7439-91-0 | -- | -- | -- |
| Lithium (Li) | 7439-93-2 | OJ5540000 | -- | -- |
| Magnesium (Mg) | 7439-95-4 | OM2100000 | 15 (dust) as oxide | -- |
| Manganese (Mn) | 7439-96-5 | OO9275000 | C 5 | C 1; STEL ^G 3 |
| Molybdenum (Mo) | 7439-98-7 | QA4680000 | 5 (soluble) 15 (total insoluble dust) | -- |
| Nickel (Ni) | 7440-02-0 | QR5950000 | 1 | 0.015, Ca |
| Phosphorus (P) | 7723-14-0 | TH3500000 | 0.1 | 0.1 |
| Lead (Pb) | 7439-92-1 | OF7525000 | 0.05 | 0.05 |
| Antimony (Sb) | 7440-36-0 | CC4025000 | 0.5 | 0.5 |
| Selenium (Se) | 7782-49-2 | VS7700000 | 0.2 | 0.2 |
| Tin (Sn) | 7440-31-5 | XP7320000 | 2 | 2 |
| Strontium (Sr) | 7440-24-6 | WK7700000 | -- | -- |
| Tellurium (Te) | 13494-80-9 | WY2625000 | 0.1 | 0.1 |
| Titanium (Ti) | 7440-32-6 | XR1700000 | 15 as dioxide | Ca as the oxide |
| Thallium (Tl) | 7440-28-0 | XG3425000 | 0.1 (skin) (soluble) | 0.1 (skin) (soluble) |
| Vanadium (V) | 7440-62-2 | YW1355000 | C 0.5 (respirable) as pentoxide | C 0.05 as pentoxide |
| Tungsten (W) | 7440-33-7 | YO7175000 | -- | 5; STEL 10 |
| Yttrium (Y) | 7440-65-5 | ZG2980000 | 1 | 1 |
| Zinc (Zn) | 7440-66-6 | ZG8600000 | 5 (fume, respirable dust) as oxide 15 (total dust) as oxide | 5 (dust, fume) as oxide C 15 (dust) as oxide STEL 10 (fume) as oxide |
| Zirconium (Zr) | 7440-67-7 | ZH7070000 | 5 | 5; STEL 10 |

^E C: ceiling
^F Ca: carcinogen
^G STEL: short-term exposure limit

| TABLE 3. MEASUREMENT WAVELENGTHS (λ), DETECTION LIMITS (LOD) AND RECOVERY DATA FROM INTERLABORATORY RESULTS | | | | | | | | |
|---|--|---------------------------------|--------------------------|---------------------------------------|---------------------------------|---------------------------------------|----------------------------|---------------------------------------|
| Element | Wavelength ^H (λ , nm) | LOD ^I (ug/sample) | Low Level (ug/sample) | % Recovery (%RSD; N ^J) | Medium level (ug/ sample) | % Recovery (%RSD; N ^J) | High Level (ug/ sample) | % Recovery (%RSD; N ^J) |
| Ag | 328.068 | 0.020 | 5.0 | 93.2 (17; 7) | 10.1 | 83.5 (26; 7) | 20.1 | 68.2 (52; 7) |
| Al | 396.152 | 0.38 | 10.6 | 95.7 (6.1; 7) | 30.9 | 95.7 (3.1; 7) | 60.8 | 96.2 (2.4; 7) |
| As | 189.042 | 0.099 | 5.0 | 99.4 (7.3; 7) | 20.2 | 103 (5.3; 8) | 40.1 | 102 (5.8; 8) |
| Ba | 455.404 | 0.55 | 2.21 | 97.0 (8.4; 8) | 7.3 | 96.9 (2.5; 7 ^K) | 15.2 | 99.9 (5.0; 8) |
| Be | 313.042 | 0.0064 | 2.01 | 101 (4.4; 9) | 7.0 | 101 (6.8; 9) | 14.9 | 100 (5.1; 9) |
| Ca | 315.887 | 3.9 | 114 | 95.8 (16; 8) | 165 | 97.4 (15; 8) | 215 | 95.8 (13; 8) |
| Cd | 226.502 | 0.0052 | 2.01 | 101 (3.6; 9) | 7.0 | 101 (4.0; 9) | 14.9 | 102 (1.9; 8) |
| Co | 228.616 | 0.0090 | 2.01 | 103 (6.8; 9) | 7.0 | 102 (5.7; 9) | 14.9 | 102 (5.8; 9) |
| Cr | 267.716 | 0.28 | 2.91 | 80.2 (16; 8) | 7.9 | 96.3 (7.2; 9) | 15.8 | 97.2 (3.5; 9) |
| Cu | 324.754 | 0.15 | 3.16 | 100 (4.5; 8 ^K) | 15.1 | 101 (4.0; 9) | 29.9 | 100 (3.2; 9) |
| Fe | 259.941 | 5.3 | 21.3 | 107 (15; 9) | 41.0 | 104 (5.5; 9) | 80.5 | 103 (5.4; 9) |
| In | 230.606 | 0.26 | 5.0 | 92.1 (33; 5) | 14.9 | 90.8 (27; 5 ^K) | 39.7 | 86.2 (32; 5) |
| K | 766.491 | 0.70 | 10.6 | 89.0 (36; 5) | 15.7 | 98.0 (24; 6) | 20.7 | 106 (20; 6) |
| La | 408.672 | 0.026 | 3.01 | 101 (8.1; 4) | 10.1 | 102 (7.2; 4) | 20.1 | 99.9 (7.9; 4) |
| Li | 670.780 | 0.010 | 2.01 | 93.0 (8.5; 7) | 7.0 | 94.9 (7.0; 7) | 14.9 | 98.6 (5.2; 7) |
| Mg | 279.079 | 1.1 | 12.7 | 93.9 (16; 7) | 27.9 | 98.7 (9.1; 7) | 103 | 101 (7.2; 7) |
| Mn | 294.921 | 0.031 | 2.01 | 99.8 (7.6; 9) | 7.0 | 100 (6.1; 9) | 14.9 | 100 (5.7; 9) |
| Mo | 202.095 | 0.021 | 2.01 | 101 (6.2; 9) | 7.1 | 102 (4.8; 9) | 15.0 | 102 (5.2; 9) |
| Ni | 231.604 | 0.56 | 2.01 | 108 (9.6; 9) | 7.0 | 104 (7.4; 9) | 14.9 | 103 (7.0; 9) |
| P | 178.287 | 0.27 | 10.1 | 104 (9.0; 5) | 24.9 | 103 (8.9; 6) | 99 | 102 (1.7; 5 ^K) |
| Pb | 220.353 | 0.062 | 10.0 | 101 (6.2; 9) | 25.2 | 100 (5.3; 9) | 100 | 100 (7.3; 9) |
| ^H Commonly used wavelength; choose wavelength appropriate for your instrument settings [3,4] ^I LOD values calculated using the responses of 7 media blanks, prepared following the microwave sample preparation in NIOSH 7302 ^J Mean recovery & relative standard deviation for N = number of laboratories reporting results for each element ^K Excludes outlier(s) (Grubbs' test) | | | | | | | | |

Table 3 continued from page 9

| TABLE 3. MEASUREMENT WAVELENGTHS (λ), DETECTION LIMITS (LOD) AND RECOVERY DATA FROM INTERLABORATORY RESULTS | | | | | | | | |
|---|--|---------------------------------|--------------------------|---------------------------------------|---------------------------------|---------------------------------------|----------------------------|---------------------------------------|
| Element | Wavelength ^H (λ), nm | LOD ^I (ug/sample) | Low Level (ug/sample) | % Recovery (%RSD; N ^J) | Medium level (ug/ sample) | % Recovery (%RSD; N ^J) | High Level (ug/ sample) | % Recovery (%RSD; N ^J) |
| Sb | 206.833 | 0.11 | 5.0 | 99.1 (6.7; 8) | 25.1 | 99.0 (5.7; 9) | 40.2 | 100 (3.6; 8 ^K) |
| Se | 196.090 | 0.14 | 3.0 | 112 (15; 6) | 15.1 | 109 (8.7; 8) | 30.1 | 104 (10; 8) |
| Sn | 189.991 | 0.065 | 2.01 | 98.7 (26; 4) | 7.0 | 96.9 (18; 6) | 14.9 | 103 (5.0; 5 ^K) |
| Sr | 407.771 | 0.014 | 2.01 | 100 (1.9; 6 ^K) | 7.1 | 102 (7.5; 7) | 15.0 | 101 (6.1; 7) |
| Te | 214.281 | 0.22 | 3.0 | 104 (18; 5) | 12.6 | 103 (7.7; 5) | 20.1 | 101 (12; 5) |
| Ti | 334.941 | 0.042 | 2.01 | 105 (5.7; 7) | 7.0 | 101 (10; 7) | 14.9 | 103 (3.4; 6 ^K) |
| Tl | 190.864 | 0.046 | 3.0 | 102 (7.1; 6) | 10.1 | 99.6 (5.8; 7) | 20.1 | 98.3 (7.5; 7) |
| V | 311.071 | 0.0091 | 3.02 | 101 (5.7; 9) | 7.0 | 102 (6.2; 9) | 14.9 | 102 (5.8; 9) |
| W | 207.911 | 0.055 | 10.1 | 83.0 (12; 5) | 25.1 | 97.6 (12; 5) | 40.2 | 96.4 (16; 5) |
| Y | 371.030 | 0.0039 | 2.01 | 101 (3.8; 5) | 7.1 | 102 (5.9; 5) | 15.0 | 101 (4.8; 5) |
| Zn | 213.856 | 0.69 | 5.2 | 101 (6.0; 9) | 25.1 | 101 (4.9; 9) | 59.7 | 101 (4.8; 9) |
| Zr | 339.198 | 0.0099 | 2.01 | 101 (6.2; 5) | 7.0 | 99.5 (9.2; 6) | 14.9 | 93.1 (19; 6) |

^H Commonly used wavelength; choose wavelength appropriate for your instrument settings [3,4]
^I LOD values calculated using the responses of 7 media blanks, prepared following the microwave sample preparation in NIOSH 7302
^J Mean recovery & relative standard deviation for N = number of laboratories reporting results for each element
^K Excludes outlier(s) (Grubbs' test)

TABLE 4. RANGE, BIAS, PRECISION (\bar{S}_r and \hat{S}_{rt}^N) AND ACCURACY DATA FROM INTERLABORATORY RESULTS

| Element | n ^L | Range, ug/sample | Bias | \bar{S}_r^M | \hat{S}_{rt}^N | Accuracy (%) |
|---------|----------------|------------------|----------|---------------|------------------|--------------|
| Ag | 21 | 5.0 to 20.1 | -0.184 | 0.041 | 0.065 | 29.0 |
| Al | 21 | 10.6 to 60.8 | -0.0414 | 0.006 | 0.050 | 12.4 |
| As | 23 | 5.0 to 40.1 | 0.0141 | 0.016 | 0.052 | 10.7 |
| Ba | 23 | 2.21 to 15.2 | -0.0206 | 0.036 | 0.062 | 12.8 |
| Be | 27 | 2.01 to 14.9 | 0.00536 | 0.025 | 0.056 | 11.0 |
| Ca | 24 | 114 to 215 | -0.0367 | 0.001 | 0.050 | 11.9 |
| Cd | 26 | 2.01 to 14.9 | 0.0133 | 0.022 | 0.055 | 11.1 |
| Co | 27 | 2.01 to 14.9 | 0.0238 | 0.036 | 0.062 | 12.9 |
| Cr | 26 | 2.91 to 15.8 | -0.0281 | 0.046 | 0.068 | 14.4 |
| Cu | 26 | 3.16 to 29.9 | 0.00347 | 0.017 | 0.053 | 10.4 |
| Fe | 27 | 21.3 to 80.5 | 0.0476 | 0.011 | 0.051 | 13.2 |
| In | 15 | 5.0 to 39.7 | -0.103 | 0.056 | 0.075 | 22.6 |
| K | 17 | 10.6 to 20.7 | -0.0239 | 0.029 | 0.058 | 12.3 |
| La | 12 | 3.01 to 20.1 | 0.0119 | 0.025 | 0.056 | 11.2 |
| Li | 21 | 2.01 to 14.9 | -0.0447 | 0.039 | 0.064 | 14.9 |
| Mg | 21 | 12.7 to 103 | -0.0219 | 0.012 | 0.051 | 10.9 |
| Mn | 27 | 2.01 to 14.9 | 0.00127 | 0.039 | 0.063 | 12.4 |
| Mo | 27 | 2.01 to 15.0 | 0.0169 | 0.032 | 0.060 | 12.1 |
| Ni | 27 | 2.01 to 14.9 | 0.0498 | 0.055 | 0.074 | 17.2 |
| P | 16 | 10.1 to 99 | 0.0310 | 0.010 | 0.051 | 11.5 |
| Pb | 27 | 10.0 to 100 | 0.00439 | 0.006 | 0.050 | 9.9 |
| Sb | 25 | 5.0 to 40.2 | -0.00631 | 0.013 | 0.052 | 10.2 |
| Se | 22 | 3.0 to 30.1 | 0.0864 | 0.055 | 0.075 | 20.9 |
| Sn | 15 | 2.01 to 14.9 | -0.00541 | 0.117 | 0.128 | 25.0 |
| Sr | 20 | 2.01 to 15.0 | 0.00930 | 0.011 | 0.051 | 10.2 |
| Te | 15 | 3.0 to 20.1 | 0.0256 | 0.063 | 0.081 | 16.6 |
| Ti | 20 | 2.01 to 14.9 | 0.0305 | 0.032 | 0.059 | 13.1 |
| Tl | 20 | 3.0 to 20.1 | 0.00128 | 0.030 | 0.058 | 11.4 |
| V | 27 | 3.02 to 14.9 | 0.0143 | 0.020 | 0.054 | 10.9 |
| W | 15 | 10.1 to 40.2 | -0.0240 | 0.010 | 0.051 | 11.0 |
| Y | 15 | 2.01 to 15.0 | 0.00971 | 0.020 | 0.054 | 10.7 |
| Zn | 27 | 5.2 to 59.7 | 0.00873 | 0.013 | 0.052 | 10.3 |
| Zr | 17 | 2.01 to 14.9 | -0.0206 | 0.033 | 0.060 | 12.4 |

^L n = total number of results reported for each element by up to 9 participating laboratories minus outliers (Grubbs' test, 1% confidence level)

^M \bar{S}_r = precision [17]

^N \hat{S}_{rt}^N = overall precision = $\sqrt{\bar{S}_r^2 + (0.05)^2}$; same as total precision as defined in [18,20]

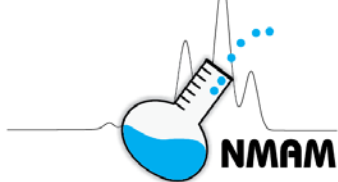

Formula: Various MW: Various CAS: Table 3 RTECS: Various

METHOD: 7400, Issue 3

EVALUATION: FULL

Issue 1: 15 May 1989
Issue 3: 14 June 2019

OSHA: 0.1 asbestos fiber (>5 μm long and ≥3:1 aspect ratio)/cc; 1 f/cc, 30 min excursion; carcinogen
NIOSH: 0.1 fiber (>5 μm long and ≥3:1 aspect ratio)/cc, for a 400 L sample; carcinogen

PROPERTIES: solid, fibrous, crystalline, anisotropic

MSHA: As OSHA

SYNONYMS: actinolite or ferroactinolite; amosite; anthophyllite; chrysotile; crocidolite; tremolite; amphibole asbestos; refractory ceramic fibers; fibrous glass

| SAMPLING | | MEASUREMENT | |
|--|--|-----------------------------------|---|
| SAMPLER: | FILTER (0. 45- to 1.2-μm mixed cellulose ester membrane, 25-mm; conductive cowl on cassette) | TECHNIQUE: | LIGHT MICROSCOPY, PHASE CONTRAST |
| FLOW RATE*: | 0.5 to 16 L/min | ANALYTE: | fibers (manual count) |
| VOL-MIN*: | 400 L @ 0.1 fiber/cc | SAMPLE PREPARATION: | Treatment of filter by acetone or dimethylformamide (DMF)/acetic acid, followed by triacetin or Euparal mounting medium [2-4] |
| -MAX*: | (step 4, Sampling) *Adjust to give 100 to 1300 fiber/mm ² | COUNTING RULES: | Described in previous version of this method as "A" rules [1,5] |
| SHIPMENT: | routine (pack to reduce mechanical and static electrical shock) (step 6, Sampling) | EQUIPMENT: | 1. positive phase-contrast microscope; 2. graticule (100-μm field of view); 3. phase-shift test slide |
| SAMPLE STABILITY: | stable | CALIBRATION: | Phase-shift test slide |
| BLANKS: | 2 to 10 field blanks per set | RANGE: | 100 to 1300 fibers/mm ² filter area |
| ACCURACY | | ESTIMATED LOD: | 7 fibers/mm ² filter area |
| RANGE STUDIED: | 80 to 100 fibers counted | PRECISION (S_r): | 0.10 to 0.12 [1]; see Evaluation of Method |
| BIAS: | see Evaluation of Method | | |
| OVERALL PRECISION (Ŝ_{rT}): | 0.115 to 0.13 [1] | | |
| ACCURACY: | see Evaluation of Method | | |

APPLICABILITY: The quantitative working range is 0.04 to 0.5 fiber/cc for a 1000-L air sample. The LOD depends on sample volume and quantity of interfering dust, and is <0.01 fiber/cc if free of interferences. The method gives an index of airborne fibers. This method can be used in conjunction with electron microscopy (e.g., Method 7402) for assistance in identification of fibers. For fibers with diameters >1 μm, polarizing light microscopy (as in NIOSH Method 7403) may be used to identify and eliminate interfering non-crystalline fibers [6]. Asbestos fibers thinner than about 0.05-0.15 μm diameter, depending on asbestos type, will not be detected by this method [7-10]. This method may be used for other materials with alternate counting rules.

INTERFERENCES: If the method is used to detect a specific type of fiber, any other fiber may interfere because all particles meeting the counting criteria are counted. Chain-like particles may appear fibrous. High levels of non-fibrous dust particles may obscure fibers in the field of view and increase the detection limit.

OTHER METHODS: This revision replaces Method 7400, issue 2 (dated 08/15/1994).

REAGENTS:

1. Acetone*, reagent grade.
NOTE: Dimethylformamide (DMF)*, reagent grade/glacial acetic acid can be used as an alternative filter clearing reagent.
2. Triacetin (glycerol triacetate), reagent grade.
NOTE: Euparal (synthetic Canada Balsam) can be used as an alternative mounting media.

*See SPECIAL PRECAUTIONS.

EQUIPMENT:

1. Sampler: Field monitor, 25-mm, 3-piece cassette with 50-mm electrically conductive extension cowl and mixed cellulose ester (MCE) filter, 0.45- to 1.2- μ m pore size, and backup pad.
NOTE 1: Analyze representative filters for fiber background before use to check for clarity and background. Discard the filter lot if mean is ≥ 5 fibers per 100 graticule fields. These are defined as laboratory blanks. Manufacturer-provided quality assurance checks on filter blanks are normally adequate as long as field blanks are analyzed as described below.
NOTE 2: The electrically conductive extension cowl reduces electrostatic effects [11]. Ground the cowl when possible during sampling.
NOTE 3: 0.8- μ m pore size filters are commonly used for personal sampling. However, 0.45- μ m filters are recommended for sampling when performing TEM analysis on the same samples. Check personal sampling pumps before use with 0.45- μ m filters to ensure they can operate at the higher pressure drop. Perform calibration with same type of filter as used for sampling.
2. Sampling pump, battery or line-powered vacuum, of sufficient capacity to meet flow rate requirements and, for personal sampling pumps, applicable ISO Standard [12], with flexible connecting tubing.
NOTE: See Step 4 in Sampling section for flow rate.
3. Wire, multi-stranded, 22-gauge; 1" hose clamp to attach wire to cassette for grounding, if needed.
4. Tape, shrink- or adhesive-, or cellulose bands.
5. Slides, glass, pre-cleaned, 25- x 75-mm.
6. Cover slips, 22- x 22-mm, No. 1 1/2, unless otherwise specified by microscope manufacturer.
7. Cover slips, as above, imprinted with a relocatable grid, where required for quality assurance or training purposes.
8. Lacquer or nail polish.

9. Knife, #10 surgical steel, curved blade, or scissors.
10. Forceps (tweezers).
11. Flash vaporization system for clearing filters on glass slides using acetone. (See ref. [11] for specifications or see manufacturer's instructions for equivalent devices.). Use a drying oven or warming plate located in fume cabinet if using DMF/glacial acetic acid.
12. Micropipettes or microsyringes, 5- μ L and 100- to 500- μ L.
13. Microscope, positive phase (dark) contrast, with green or blue filter, adjustable field iris, 8x to 10x eyepiece, and 40x to 45x phase objective (total magnification ca. 400x); numerical aperture (NA) = 0.65 to 0.75.
14. Graticule, Walton-Beckett type (Type G22 and G24 are optimized for different counting rules per Appendix C.) with 100- μ m projected diameter circular field (area = 0.00785 mm²) at the specimen plane. Alternative graticules may be used where similar performance has been demonstrated; e.g., the RIB graticule.
NOTE: The graticule is custom-made for each microscope. See APPENDIX A for the custom-ordering process.
15. Phase contrast test slide. A slide with blocks of visible ruled lines where at least one block of lines is certified as invisible under the microscope set up conditions given below.
16. Telescope, ocular phase-ring centering.
17. Stage micrometer (0.01-mm divisions).

SPECIAL PRECAUTIONS: Wear appropriate personal protection during sampling activities and analysis. It is essential that suitable gloves, eye protection, laboratory coat, etc., be used when working with the chemicals. Acetone is toxic at high exposures and is extremely flammable. Take precautions not to ignite it. Heating of acetone in volumes greater than 1 mL must be done in a ventilated laboratory fume hood using a flameless, spark-free heat source. DMF is toxic by inhalation; heating in a drying oven or warming plate located in an operating fume exhaust hood will reduce potential exposure. DMF is also toxic via absorption through the skin.

SAMPLING:

1. Calibrate each personal sampling pump with a representative sampler in line. Use a flow meter whose calibration is traceable to national or international standards.
NOTE: See NMAM guidance chapters for discussion on sampling.
2. Cassette assemblies shall be tested to ensure they are not likely to fall apart during sampling. (This testing can be undertaken by the manufacturer.) A press may be useful in ensuring a tight fit, but shall not cause the filter to be cut. To reduce contamination, seal the crease between the cassette base and the cowl with a shrink band or light-colored adhesive tape. Commercial pre-assembled cassettes may already include a taped seal. For personal sampling, fasten the uncapped open-face cassette to the worker's lapel. The open face shall be oriented downward.

NOTE: Electrically grounding the cowl is highly recommended during area sampling, where possible, but especially under conditions of low relative humidity. Use a hose clamp to secure one end of the wire (Equipment, Item 3) to the monitor's cowl. Connect the other end to an earth ground (e.g., cold water pipe). It is recognized that circumstances do not always allow this procedure.

3. Submit at least two field blanks (or 10% of the total samples, whichever is greater) for each set of samples. Handle field blanks in a manner representative of actual handling of associated samples in the set. Open field blank cassettes at the same time as other cassettes just prior to sampling. Store top covers and cassettes in a clean area (e.g., a closed bag or box) with the top covers from the sampling cassettes during the sampling period.
4. Sample at 0.5 L/min or greater [13]. Adjust sampling flow rate, Q [L/min], and time, t (min), to produce a fiber density, E , of 100 to 1300 fibers/mm² (3.85×10^4 to 5×10^5 fibers per 25-mm filter with effective collection area $A_c = 385$ mm²) for optimum counting. These variables are related to the concentration of fibers in air, L (fibers/cc), of the fibrous aerosol being sampled by:

$$t = \frac{A_c * E}{Q * L * 10^3}$$

NOTE 1: The purpose of adjusting sampling times is to obtain optimum fiber loading on the filter. The collection efficiency does not appear to be a function of flow rate in the range of 0.5 to 16 L/min for asbestos fibers [14]. However, counting efficiency is a function of filter loading, with lower loadings typically resulting in higher proportional concentrations [14-16]. A sampling rate of 1 to 4 L/min for 8 h is appropriate in atmospheres containing about 0.1 fiber/cc in the absence of significant amounts of non-asbestos dust. Dusty atmospheres require smaller sample volumes (≤ 400 L) to obtain countable samples. In such cases take short, consecutive samples and average the results over the total collection time. For documenting episodic exposures, use high flow rates (7 to 16 L/min) over shorter sampling times. In relatively clean atmospheres, where targeted fiber concentrations are much less than 0.1 fiber/cc, use larger sample volumes (3000 to 10000 L) to achieve quantifiable loadings. Take care, however, not to overload the filter with background dust. If $\geq 50\%$ of the filter surface is covered with particles, the filter may be too overloaded to count and will bias the measured fiber concentration.

NOTE 2: OSHA regulations specify a minimum sampling volume of 48 L for an excursion measurement, and a maximum sampling rate of 2.5 L/min for all personal asbestos sampling [5].

5. At the end of sampling, shut off the pump, record the time, remove the cassette from the tube attaching it to the pump, and replace top cover and end plugs. Capping the cassette before shutting off the pump and removing the tubing will cause a vacuum within the cassette and damage to the filter.
6. Ship samples with conductive cowl attached in a rigid container with packing material to protect cassettes from jostling or damage.

NOTE: Do not use untreated polystyrene foam in shipping container because electrostatic forces may cause fiber loss from sample filter.

SAMPLE PREPARATION:

Two acceptable procedures for clarifying either a whole filter or a portion of a filter are described below. These procedures are the Acetone clearance procedure and the DMF/acetic acid clearance procedure. In either procedure, the filter material is placed on a glass microscope slide. It is then made transparent (clarified). Then, either triacetin or Euparal are placed on the clarified filter and a cover slip is placed on top.

NOTE 1: The object is to produce samples with a smooth (non-grainy) background in a medium with refractive index ≤ 1.46 . An early method (P&CAM 239 in APPENDIX F) used dimethyl phthalate and diethyl oxalate [17]. This method may still be used as an alternative to those described below, but because the preparations are only stable for one to two days, the procedure is not further discussed.

NOTE 2: Other procedures use a technique for clearing the filter, either acetone (section A) or DMF/glacial acetic acid (section B), followed by mounting the cleared preparation (section C or D). Acetone collapses the filter into a gel, and has the advantage of being the fastest procedure to prepare the filter for the mounting medium. However, acetone can leave residual polymeric structures in the filter that may be counted as fibers. DMF/acetic acid dissolves the filter and does not leave residual structures to the same extent as acetone collapse.

NOTE 3: After the filter is clarified, either triacetin (section C) or Euparal (section D) are acceptable alternative mounting media. Triacetin provides reasonably permanent mounts when the amount used is restricted to $\leq 3.5 \mu\text{L}$, otherwise fiber migration has been observed in slides made with larger quantities [4]. Euparal provides permanent mounts for long-term storage (> 5 years) regardless of the amount used. Either mounting medium can be used with either filter preparation procedure, and all combinations have been demonstrated to provide equivalent fiber counts [4].

7. Prepare samples in a clean area away from any bulk samples which might contaminate the samples. Ensure that the glass slides and cover slips are free of dust and fibers.
8. Determine and record the effective sample collection or filtration area and record the information referenced against the sample ID number.
9. Cut wedges of about 1/4 for a 25-mm diameter filter using a curved-blade surgical steel knife using a rocking motion to prevent tearing. Do not use a blade that was used to open the cassette. Scissors are an option for cutting the filter. The entire filter can be used instead of a wedge, but with the understanding that the whole sample is lost if there is a problem in preparation. Place the wedge or entire filter, dust side up, on slide using forceps. To prevent cross-contamination of samples, blades or scissors should be cleaned between samples.

NOTE 1: Filters can be cut while still in the base of the cassette, or removed and cut on a special cut-stand. If a cut-stand is used it shall be cleaned between filters to ensure no cross-contamination.

NOTE 2: Static electricity will usually keep the wedge on the slide.

A. ACETONE CLEARANCE PROCEDURE

NOTE 1: The aluminum "hot block" or similar flash vaporization techniques may be used outside the laboratory [2].

NOTE 2: Excessive water in the acetone may slow the clearing of the filter. Also, filters that have been exposed to high humidity or water prior to clearing may have a grainy background.

NOTE 3: Rest the "hot block" on a ceramic plate and isolate it from any surface susceptible to heat damage unless it is designed with appropriate safety features to prevent fire or damage.

- A1. If the temperature can be varied, adjust the "hot block" to ca. 70 °C [2], otherwise switch on until ready.
- A2. Mount a wedge cut from the sample filter on a clean glass slide. Insert slide with wedge into the receiving slot at base of the "hot block." Immediately place the tip of a micropipette or microsyringe containing ca. 250 μL acetone (use the minimum volume needed to consistently clear the filter sections) into the inlet port of the PTFE cap on top of the "hot block" and inject the acetone into the vaporization chamber with a slow, steady pressure on the plunger button while holding the micropipette or microsyringe firmly in place. After waiting 3 to 5 seconds for the filter to clear, remove the micropipette or microsyringe and glass slide from their ports.

NOTE: Using excess acetone, or delivering it too fast into the "hot block" may cause material to be washed off the surface of the filter. Using insufficient acetone may cause the filter to curl.

CAUTION: Although the volume of acetone used is small, use safety precautions. Work in a well-ventilated area (e.g., laboratory fume hood). Take care not to ignite the acetone. Continuous use of this device in an unventilated space may produce unhealthful levels or even explosive acetone vapor concentrations.

B. DMF/ACETIC ACID CLEARANCE PROCEDURE

- B1. Make a mixture of 1.4mL (35% volume) of DMF, 0.6mL (15% volume) of glacial acetic acid and 2mL (50% volume) of distilled water in a dark brown vial [3]. This should be done in a fume hood to minimize exposure to chemicals. This solution must be made at least once per week and the vial shall be stored in accordance with applicable laboratory safety procedures (e.g., kept in a vented chemical cabinet rated for flammable materials).
- B2. Turn on the drying oven or warming plate (vented or located in a laboratory fume hood) and allow to come to working temperature. Place a cut filter wedge on a glass slide using forceps. Using $20 \pm 5 \mu\text{L}$ DMF solution, place several drops along the edge of the wedge and allow the solution to wick onto the filter to avoid washing fibers off the filter. Warm the slide at $60 (+2/-5)^\circ\text{C}$ for 30 minutes in the drying oven or on the warming plate.

C. TRIACETIN MOUNTS AFTER CLEARING AND COLLAPSE

- C1. Using a 5- μL micropipette or microsyringe, immediately place 3.0 to 3.5 μL triacetin on the wedge. Gently lower a clean cover slip onto the wedge at a slight angle to reduce bubble formation. Avoid excess pressure and movement of the cover glass. Do not wait longer than 30 seconds before applying the coverslip.
NOTE: If too many bubbles form or the amount of triacetin is insufficient, the cover slip may become detached within a few hours. If excessive triacetin remains at the edge of the filter under the cover slip, fiber migration may occur [4].
- C2. Mark the outline of the filter segment just inside the edge of the segment with a glass marking pen (such as a permanent ink marker) to aid in microscopic evaluation and to ensure the edge is avoided in the examination. Markings on the bottom of the slide are visible, but outside the depth of focus of fibers and this must be accounted for when positioning the microscope for counting. However, marking the bottom avoids any pressure on the coverslip. If marking the coverslip is preferred, it must be done very lightly and carefully.
- C3. Glue the edges of the cover slip to the slide using lacquer or nail polish [18]. Counting may proceed immediately after clearing and mounting are completed.
NOTE: If clearing is slow, warm the slide on a hotplate (surface temperature 50°C) for up to 15 min in order to hasten clearing. Heat carefully to prevent gas bubble formation.

D. EUPARAL MOUNTS AFTER CLEARING

- D1. Add 1 drop of Euparal solution on the middle of the wedge and 1 drop to the center of a cover slip. In order to avoid trapping air bubbles, gently lower the cover slip onto the slide at a slight angle. Warm the slide at $60 (+2/-5)^\circ\text{C}$ for 1 hour to polymerize the Euparal resin.
- D2. Mark the outline of the filter segment just inside the edge of the segment with a glass-marking pen (such as a permanent ink marker) to aid in microscopic evaluation and to ensure the edge is avoided in the examination. Markings on the bottom of the slide are visible, but outside the depth of focus of fibers and this must be accounted for when positioning the microscope for counting. However, marking the bottom avoids any pressure on the coverslip. If marking the coverslip is preferred, it must be done very lightly and carefully.
- D3. It is not necessary to seal the edges of the cover slip with nail polish if Euparal is used. Counting may proceed immediately after clearing and mounting are completed.

CALIBRATION AND QUALITY CONTROL:

10. Microscope adjustments. Follow the manufacturer's instructions for centering and focusing the objectives, condenser, stage, and lamp, if applicable. At least once daily, and preferably at regular intervals throughout the day, use a phase telescope ocular (or Bertrand lens, for some microscopes) to ensure that the phase rings (annular diaphragm and phase-shifting elements) are concentric. With each microscope, keep a paper or electronic logbook in which to record the dates of microscope cleanings and major servicing.
 - a. Each time a sample is examined, do the following:
 - i. Adjust the light source for even illumination across the field of view at the condenser iris. Use Köhler illumination, if available. With some microscopes, the illumination may have to be set up with bright field optics before aligning the phase contrast elements.
 - ii. Focus on the particulate material to be examined (do not focus on the marking line).
 - iii. Using the condenser focus, make sure that the field iris is in focus, centered on the sample, and open only enough to fully illuminate the field of view.
 - b. Check the phase-shift detection limit of the microscope periodically for each microscopist/microscope combination:
 - i. Center the certified phase-contrast test slide under the phase objective.
 - ii. Bring the blocks of grooved lines into focus in the graticule area.

NOTE: The slide contains seven blocks of grooves (ca. 20 grooves per block) in descending order of visibility. For asbestos counting, it is intended that some blocks of lines are completely visible and one or more are completely invisible when centered in the graticule area (blocks in between may be partially visible). The visibility of the blocks must match the statements in the accompanying certificate [19]. A microscope which fails to meet this requirement for a test slide has resolution either too low or too high for fiber counting.

 - iii. If image quality deteriorates, clean the microscope optics. If the problem persists, consult the microscope manufacturer.
 - c. Measure the projected diameter of the Walton-Beckett type graticule to assure that it is $100\ \mu\text{m} \pm 2\ \mu\text{m}$. Use the measured value to calculate the actual area of graticule. Check the measured value at the minimum and maximum interpupillary distance of the eyepieces. If the diameter changes, then the diameter may change any time a different microscopist uses the microscope and changes the interpupillary distance. If service is performed on the microscope, or components of the microscope are changed, measure the projected diameter again as changes may occur if the tube length or the location of the graticule in the eyepiece is changed.
 - i. Center the stage micrometer under the 40X objective of the microscope.
 - ii. Bring the scale into focus in the graticule area
 - iii. The lines in the scale will appear wide. Using the mechanical stage of the microscope, manipulate the slide until the graticule is at one edge of a major line of the stage micrometer.
 - iv. Estimate the diameter of the graticule using edges of the lines of the stage micrometer. Do not attempt to use the center of the micrometer lines.
 - v. If the diameter is greater than $102\ \mu\text{m}$ or less than $98\ \mu\text{m}$, determine if the inter-pupillary distance is correct for the analyst. If it is, then the microscope must be adjusted by someone qualified to service the microscope, or the graticule replaced by one meeting the projected diameter specification.
11. Determine a microscopist's ability to observe, measure, and count fibers.

NOTE: Prior to examining samples, microscopists shall undergo training to observe, measure, and count fibers and the results of such training shall be available for inspection. A procedure for such training, which allows proficiency to be demonstrated quantitatively, may be found in Appendix B.
12. Document the laboratory's precision for each microscopist for replicate fiber counts.

- a. Maintain as part of the laboratory quality assurance program a set of reference slides to be used on a daily basis [20]. These slides shall consist of filter preparations including a range of loadings and background dust levels from a variety of sources including both field and reference samples (e.g., PAT, AAR, or commercial samples). The Quality Assurance Officer shall maintain custody of the reference slides and shall supply each microscopist with a minimum of one reference slide per workday. Change the labels on the reference slides periodically so that the microscopist does not become familiar with the samples.
 - b. From blind repeat counts on reference slides, estimate the laboratory intra- and inter-microscopist precision. Obtain separate values of relative standard deviation (S_r) for each sample matrix analyzed in each of the following ranges: 5 to 20 fibers in 100 graticule fields, >20 to 50 fibers in 100 graticule fields, and >50 to 100 fibers in 100 graticule fields. Maintain control charts for each of these data files.
 - c. Alternatively, a laboratory may develop an analytical uncertainty model from intra- and inter-microscopist precision measurements (but, in practice, most laboratories will choose option b).
NOTE: Certain sample matrices (e.g., asbestos cement) have been shown to give poor precision [23].
13. Prepare and count field blanks along with the field samples. Report counts on each field blank.
NOTE 1: The identity of blank filters shall be unknown to the microscopist until all counts have been completed.
NOTE 2: If a field blank yields greater than 7 fibers per 100 graticule fields, report possible contamination of the samples.
 14. Perform blind recounts by the same microscopist on 10% of filters counted (slides relabeled by a person other than the microscopist). Use the following test to determine whether a pair of counts by the same microscopist on the same filter shall be rejected because of possible bias: Discard the data if the absolute value of the difference between the square roots of the two counts (in fiber/mm²) exceeds $2.77XS'_r$ where X is the average of the square roots of the two fiber counts (in fiber/mm²) and $S'_r = (S_r/2)$ where S_r is the intra-microscopist relative standard deviation for the appropriate count range (in fibers) determined in step 12. For more complete discussions see reference [20].
NOTE 1: Fiber counting as the measurement of randomly placed fibers may be described by a Poisson distribution, so that a square root transformation of the fiber count data will result in approximately normally distributed data [20].
NOTE 2: If a pair of counts is rejected by this test, recount all other samples in the set and test the new counts against the first counts. Discard all rejected paired counts. It is not necessary to use this statistic on blank counts.
NOTE 3: Do not use an intra-microscopist variation calculated from standard relocatable test slides (Appendix B) for this test.
 15. The microscopist is a critical part of this analytical procedure. Care must be taken to provide a non-stressful and comfortable environment for fiber counting. Use an ergonomically designed chair, with the microscope eyepiece situated at a comfortable height for viewing. Set external lighting at a similar level to the illumination level in the microscope to reduce eye fatigue. In addition, microscopists shall take 10- to 20-minute breaks from the microscope every one or two hours to limit fatigue [21]. During these breaks, eye and upper back, and neck exercises can be performed to relieve strain.
 16. All laboratories engaged in asbestos counting shall participate in a proficiency testing program such as the AIHA Industrial Hygiene Proficiency Analytical Testing (IHPAT) Program for asbestos.
 17. Each laboratory analyzing asbestos samples shall implement an interlaboratory quality assurance program that as a minimum includes participation of at least two other independent laboratories. Each laboratory shall participate in round robin testing at least once every 6 months with at least all the other laboratories in its interlaboratory quality assurance group. Each laboratory shall submit slides typical of its own work load for use in this program. The round robin shall be designed and results analyzed using appropriate statistical methodology.

MEASUREMENT:

18. Center the slide on the stage of the calibrated microscope under the objective lens. Focus the microscope on the sample-containing plane of the filter.
19. Adjust the microscope (Step 10).
20. Counting rules: (same as P&CAM 239 rules [1,17,22]: see examples in APPENDIX C).
 - a. Count any fiber longer than 5 μm which lies entirely within the graticule area.
 - i. Count only fibers longer than 5 μm .
 - ii. Measure length of curved fibers along the curve. Count only fibers with a length-to-width ratio equal to or greater than 3:1.
 - b. For fibers which cross the boundary of the graticule field:
 - i. Count as 1/2 fiber any fiber with only one end lying within the graticule area, provided that the fiber meets the criteria of rule "a" above.
 - ii. Do not count any fiber which crosses the graticule boundary more than once.
 - iii. Reject and do not count all other fibers.
 - c. Count bundles of fibers as one fiber unless individual fibers can be identified by observing both ends of a fiber.
 - d. Count enough graticule fields to yield 100 fibers. Count a minimum of 20 fields. Stop at 100 graticule fields regardless of count.
21. Start counting from the tip of the filter wedge and progress along a radial line to the outer edge. Shift up or down on the filter, and continue in the reverse direction. Select graticule fields randomly. Ensure that, as a minimum, each analysis covers one radial line from the filter center to the outer edge of the filter. When an agglomerate or bubble covers ca. 1/8 or more of the graticule field, reject the graticule field and select another. [35] Do not report rejected graticule fields in the total number counted.

NOTE 1: When counting a graticule field, continuously scan a range of focal planes by moving the fine focus knob to detect very fine fibers which have become embedded in the filter. The small-diameter fibers will be very faint but are an important contribution to the total count. A minimum counting time of 15 s per field is appropriate for accurate counting.

NOTE 2: Do not count at the outside edge of the filter, or at edges where the filter was cut, as the fiber distribution may be disturbed in these areas. Move in at least 1 mm from the edge (i.e., inside the marked line).

NOTE 3: Under certain conditions, electrostatic charge may affect the sampling of fibers. These electrostatic effects are most likely to occur when the relative humidity is low (below 20%), and when sampling is performed near the source of aerosol. The result is that deposition of fibers on the filter is reduced, especially near the edge of the filter. If such a pattern is noted during fiber counting, choose fields as close to the center of the filter as possible [11].

NOTE 4: Counts are to be recorded on a paper or electronic data sheet that provides, as a minimum, record of the counts for each field, filter identification number, analyst's name, date, total fibers counted, total fields counted, mean count, fiber density, and commentary. The average count is calculated by dividing the total fiber count by the number of fields observed. Fiber density (fibers/ mm^2) is defined as the average count (fibers/field) divided by the field (graticule) area (mm^2/field).

CALCULATIONS AND REPORTING OF RESULTS:

22. Calculate and report fiber density on the filter, E (fibers/ mm^2), by dividing the mean fiber count per graticule field, F/n_f , minus the mean field blank count per graticule field, B/n_b , by the graticule field area, A_f :

$$E = \frac{\left(\frac{F}{n_f}\right) - \left(\frac{B}{n_b}\right)}{A_f}, \text{ fibers}/\text{mm}^2$$

NOTE 1: $A_r=0.00785 \text{ mm}^2$ is the area for a graticule with a projected diameter of $100 \mu\text{m}$. The actual area shall be calculated using the measured diameter of the graticule. The measured diameter shall be $100 \pm 2 \mu\text{m}$ at the proper magnification. The diameter of the graticule shall be re-measured whenever the microscope is serviced or if necessary if there is a change in measured size with inter-pupillary distance (e.g., between different microscopists).

NOTE 2: Fiber counts above 1300 fibers/mm^2 and fiber counts from samples with $>50\%$ of filter area covered with particulate shall be reported as "uncountable" or "probably biased." Fiber counts outside the $100\text{--}1300 \text{ fiber/mm}^2$ range shall be reported as having "greater than optimal variability" and as being "probably biased."

23. Calculate and report the concentration, (C) in fibers/cc, of fibers in the air volume sampled, (V) in liters, using the effective collection area of the filter, A_c (nominally 385 mm^2 for a 25-mm filter):

$$C = \frac{EA_c}{V * 10^3}$$

NOTE: The area varies according to the cassette inner diameter, where it contacts the filter, which could vary between manufacturers and even between production runs. For most accurate results the value of A_c may be checked and adjusted accordingly, but, in practice, the variation in this parameter is very small in comparison to other sources of uncertainty.

24. Report intra- and interlaboratory relative standard deviations with each set of results.

NOTE: Precision depends on the total number of fibers counted [1,24]. Relative standard deviation is documented in references [1,24-25] for fiber counts up to 100 fibers in 100 graticule fields. Comparability of interlaboratory results is discussed below. As a first approximation, use 213% above and 49% below the count as the upper and lower confidence limits for fiber counts greater than 20 (Figure 1).

EVALUATION OF METHOD:

Summary of Method Revisions:

Each revision or release clarified minor points of grammar and procedure as well as major changes. This summary lists the major changes only.

The initial US Public Health Service/NIOSH method for counting fibers was published in 1968 [26]. It was based upon the British Hygiene standard [27] and procedures developed by the British Asbestos Research Council. The procedure was published in the NIOSH Criteria for a Recommended Standard [28] Section VIII, Appendix I (1972).

An informal draft version was used until 1976 when NIOSH issued it as P & CAM 239. It was published in the NIOSH Manual of Analytical Methods, 2nd ed., Vol. 1, P&CAM 239, U.S. Department of Health, Education, and Welfare Pub. (NIOSH) 11-157-A (1977) [17].

NIOSH Method 7400 Issued 15 February 1984

In 1984, the NIOSH P&CAM 239 Fiber counting method was renamed Method 7400 and rewritten to be in the standard format for inclusion in the NIOSH Manual of Analytical Methods. This revision included changes in three areas:

1. Sampling: The change from a 37-mm to a 25-mm filter improved sensitivity for similar air volumes. The change in flow rates allowed for 2 m^3 full-shift samples to be collected, providing that the filter is not overloaded with non-fibrous particulates. The collection efficiency of the sampler is not a function of flow rate in the range 0.5 to 16 L/min [17].
2. Sample preparation technique: The acetone vapor-triacetin preparation technique was included as a faster, more permanent mounting technique than the dimethyl phthalate/diethyl oxalate method of

P&CAM 239 [2,7,17]. The aluminum "hot block" technique minimizes the amount of acetone needed to prepare each sample.

3. Measurement:

- a. The Walton-Beckett graticule standardizes the area observed [21,29-30].
- b. A phase shift test slide standardizes microscope optics [31].
- c. Because of past inaccuracies associated with low fiber counts, the minimum recommended loading was increased to 100 fibers/mm² filter area (a total of 78.5 fibers counted in 100 fields, each with field area = 0.00785 mm²). Lower levels generally result in an overestimate of the fiber count when compared to results in the recommended analytical range [15]. The recommended loadings are expected to yield intra-microscopist S_r in the range of 0.10 to 0.17 [32, 36].
- d. An alternative set of counting rules (B rules) was introduced to improve precision of counting.

NIOSH Method 7400 Issued 15 February 1984, Revision #1 15 May 1985

Revision #1 included a discussion of interlaboratory variability and comparison of the A and B counting rules.

NIOSH Method 7400 Issued 02 February 1984, Revision #2 15 May 1986

Revision # 2 added an expanded discussion of interlaboratory variability and comparison of the A and B counting rules. It moved the "B" rules to an appendix as alternate counting rules (which should be used when counting man-made mineral fibers, e.g., fibrous glass, refractory ceramic fibers, etc.). It added three Appendices:

- a. Appendix A: Calibration of the Walton Beckett Graticule
- b. Appendix B: Examples of Counting Rules
- c. Appendix C: Alternate Counting Rules

NIOSH Method 7400 Issued 02 February 1984, Issue 1: Revision #3 15 May 1989

Issue 1: Revision #3 corrected some technical issues and clarified the method language.

NIOSH Method 7400 Issued 02 February 1984, Issue 2: 15 August 1994

Issue 2 refined the method language, added some procedural notes and added an additional Appendix D listing Equivalent Limits of Detection and Quantitation.

NIOSH Method 7400 Issued 02 February 1984, Issue 3: 29 April 2019

Issue 3 of this Method incorporates:

1. More accurate values for the minimum width limits for asbestos fiber detection. A value of 0.15 μm for chrysotile and 0.05 μm for amphibole asbestos is based on published research [7,8]. A recent user check confirms that these values are achievable [10]. However, not all microscopists can see finer chrysotile fibers between 0.15 μm and 0.2 μm without adequate training [33-34]. Note that PCM does not distinguish between asbestos types.
2. DMF/acetic acid as an alternative filter clearing procedure to acetone, and Euparal as an alternative mounting medium to triacetin. Either mounting medium is used with either clearing procedure. The DMF/acetic acid procedure does not leave undissolved residues from the filter medium, which may appear as fibers. Euparal produces permanent mounts regardless of the quantity of medium used [3]. These alternatives have been shown in a user-check to provide fiber counts that are not significantly different from counts in slides made from the original dimethyl phthalate/diethyl oxalate procedure [4]. This revision also allows the continued use of dimethyl phthalate/diethyl oxalate, if preferred.

3. A generic description of phase-shift test slides, since changes in the manufacture have led to confusion [19]. The description now only requires the slides to have a certificate stating that there are fully visible blocks and invisible blocks, so that the required phase-shift is bracketed. The microscopist is expected to be able to visualize a slide according to its certificate. Newer slides have been shown in a user-check to provide fiber counts that are not significantly different from counts in slides where the original version of the phase shift test slide was used for calibration [10].
4. Standard relocatable test slides as an additional non-mandatory quality assurance Appendix, and as documentation of inter- and intra-microscopist precision without the contribution from the selection of counting fields. Several user-checks have demonstrated increases in average analyst performance after training on these slides [33-34].
5. Guidance on the calculation of an expanded uncertainty budget. This guidance allows users to determine expanded uncertainty as required under international standards [35].
6. Re-numbering of appendices.

INTERLABORATORY COMPARABILITY

An international collaborative study involved 16 laboratories using prepared slides from the asbestos cement, milling, mining, textile, and friction material industries [23]. The relative standard deviations (S_r) varied with sample type and laboratory. The ranges were:

| Rules | Intralaboratory S_r | Interlaboratory S_r | Overall S_r |
|-------------------------------|-----------------------|-----------------------|---------------|
| AIA (NIOSH A Rules)* | 0.12 to 0.40 | 0.27 to 0.85 | 0.46 |
| Modified CRS (NIOSH B Rules)* | 0.11 to 0.29 | 0.20 to 0.35 | 0.25 |

*Under AIA (Asbestos International Association) rules, only fibers having a diameter less than 3 μm are counted and fibers attached to particles larger than 3 μm are not counted. NIOSH A Rules are otherwise similar to the AIA rules.

A NIOSH study conducted using field samples of asbestos gave intralaboratory S_r in the range 0.17 to 0.25 and an interlaboratory S_r of 0.45 [20]. This agrees well with other recent studies [21,23-24,36].

At this time, there is no independent means for assessing the overall accuracy of this method. One measure of reliability is to estimate how well the count for a single sample agrees with the mean count from a large number of laboratories. The following discussion indicates how this estimation can be carried out based on measurements of the interlaboratory variability, as well as showing how the results of this method relate to the theoretically attainable counting precision and to measured intra- and interlaboratory S_r (NOTE: The following discussion does not include bias estimates and cannot be taken to indicate that lightly loaded samples are as accurate as properly loaded ones).

Theoretically, the process of counting randomly (Poisson) distributed fibers on a filter surface will give a S_r that depends on the number, N , of fibers counted: $S_r = \frac{1}{\sqrt{N}}$

Thus, S_r is 0.1 for 100 fibers and 0.32 for 10 fibers counted. The actual S_r found in a number of studies is greater than these theoretical numbers [15,25,30,36].

An additional component of variability comes primarily from subjective interlaboratory differences. In a study of ten microscopists in a continuing sample exchange program, Ogden [24] found this subjective component of intralaboratory S_r to be approximately 0.2 and estimated the overall S_r by the term:

$$\frac{\sqrt{N+(0.2+N)^2}}{N}$$

Ogden found that the 90% confidence interval of the individual intralaboratory counts in relation to the means were $+2 S_r$ and $-1.5 S_r$. In this program, one sample out of ten was a quality control sample. For

laboratories not engaged in an intensive quality assurance program, the subjective component of variability can be higher.

In a study of field sample results in 46 laboratories, the Asbestos Information Association (AIA) also found that the variability had both a constant component and one that depended on the fiber count [18]. These results gave a subjective interlaboratory component of S_r (on the same basis as Ogden's) for field samples of ca. 0.45. A similar value was obtained for 12 laboratories analyzing a set of 24 field samples [36]. This value falls slightly above the range of S_r (0.25 to 0.42 for 1984–85) found for 80 reference laboratories in the NIOSH PAT program for laboratory-generated samples [25].

A number of factors influence intralaboratory S_r for a given laboratory, such as that laboratory's actual counting performance and the type of samples being analyzed. In the absence of other information, such as from an interlaboratory quality assurance program using field samples, the value for the subjective component of variability is chosen as 0.45. It is recommended that each laboratory establish an interlaboratory quality assurance program to improve their performance and thus reduce the intralaboratory S_r .

The above relative standard deviations apply when the population mean has been determined. It is more useful, however, for laboratories to estimate the 90% confidence for of the count distribution for both interlaboratory and intralaboratory results [24].

For example, if a sample yields a count of 24 fibers, Figure 1 indicates that the mean interlaboratory count will fall within the range of 227% above and 52% below that value 90% of the time. These percentages can be applied directly to the air concentrations as well. If, for instance, this sample (24 fibers counted) represented a 500-L volume, then the measured concentration is 0.02 fibers/cc (assuming 100 fields counted, 25-mm filter, 0.00785 mm² counting field area). If this same sample were counted by a group of laboratories, there is a 90% probability that the mean would fall between 0.01 and 0.08 fiber/cc. These limits are to be reported in any comparison of results between laboratories.

Note that the interlaboratory S_r of 0.45 used to derive Figure 1 is used as an estimate for a random group of laboratories. If several laboratories belonging to a quality assurance group can show that their interlaboratory S_r is smaller, then it is more correct to use that smaller S_r . However, the estimated interlaboratory S_r of 0.45 is to be used in the absence of such information. Note also that it has been found that interlaboratory S_r can be higher for certain types of samples, such as asbestos cement [23].

Quite often the estimated airborne concentration from an asbestos analysis is used to compare to a regulatory standard. For instance, if one is trying to show compliance with an 0.5 fiber/cc standard using a single sample on which 100 fibers have been counted, then Figure 1 indicates that the 0.5 fiber/cc standard must be 213% higher than the measured air concentration. This indicates that if one measures a fiber concentration of 0.16 fiber/cc (100 fibers counted), then the mean fiber count by a group of laboratories (of which the compliance laboratory might be one) has a 95% chance of being less than 0.5 fibers/cc; i.e., $0.16 + 2.13 \times 0.16 = 0.5$.

It can be seen from Figure 1 that the Poisson component of the variability is not very important unless the number of fibers counted is small. Therefore, a further approximation is to simply use +213% and -49% as the upper and lower confidence values of the mean for a 100-fiber count.

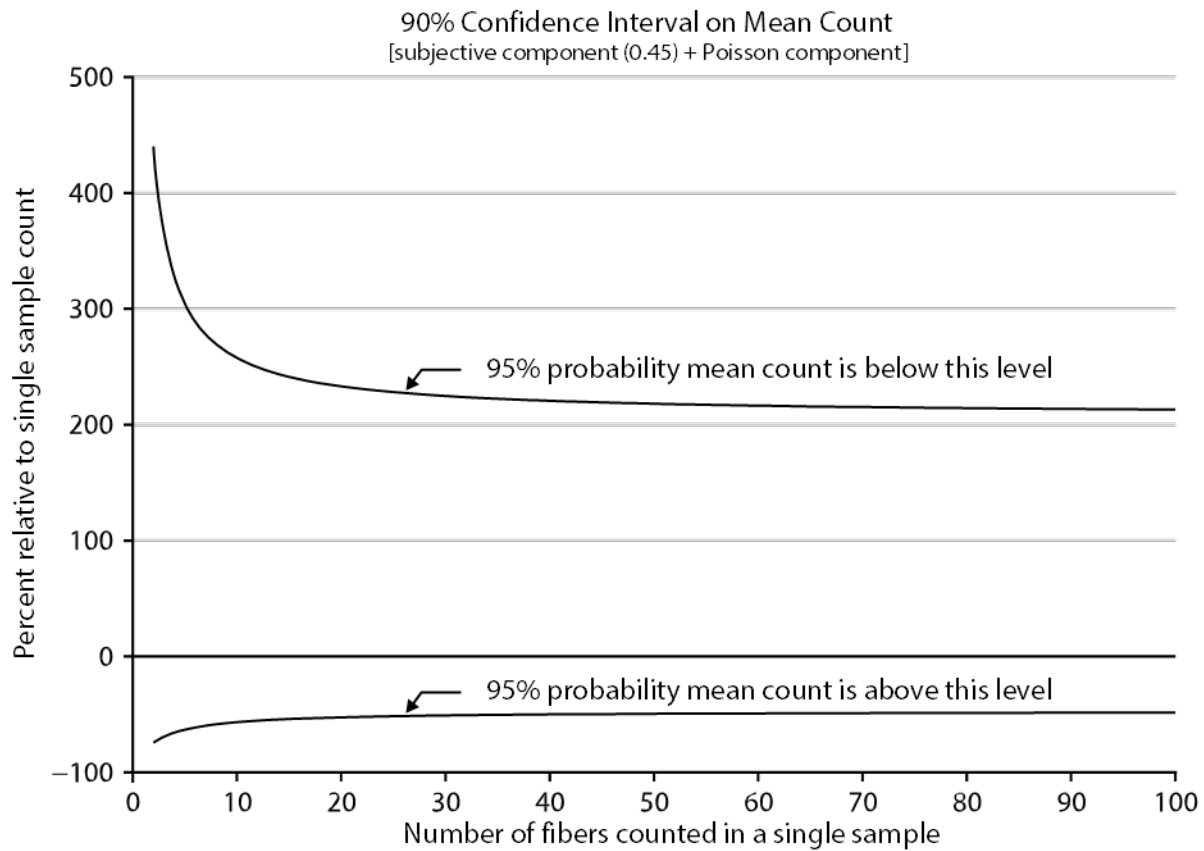

Figure 1. Interlaboratory precision of fiber counts

The curves in Figure 1 are defined by the following equations:

$$UCL = \frac{2X + 2.25 + \sqrt{(2.25 + 2X)^2 - 4(1 - 2.25S_r^2)X^2}}{2(1 - 2.25S_r^2)}$$

and

$$LCL = \frac{2X + 4 - \sqrt{((4 + 2x)^2 - 4(1 - 4S_r^2)X^2)}}{2(1 - 4S_r^2)}$$

where S_r = subjective interlaboratory relative standard deviation, which is close to the total interlaboratory S_r when approximately 100 fibers are counted, X = total fibers counted on sample, UCL = upper 95% confidence limit, and LCL = lower 95% confidence limit.

NOTE: The range between these two limits represents 90% of the total range.

It is also possible to use a similar approach to determining expanded uncertainty within a single laboratory.

The formula:

$$S_r = \frac{\sqrt{N + (0.2N)^2}}{N}$$

suggests that if n is the number of counts taken in a single reading, then the distribution of

$$\frac{n - N}{\sqrt{n + S_r^2 N^2}}$$

though unknown, depends only weakly on N, because the mean and variance are independent of N. In fact, from many readings by a number of microscopists, with N equal to the mean across the microscopists, confidence intervals were determined [24] as:

$$-1.8 \leq \frac{n - N}{\sqrt{N + S_r^2 N^2}} \leq +2.6$$

By solving the two quadratic equations at the two extreme limits for N in terms of n, confidence limits enclosing the consensus mean N, given single measurements n are easily obtained: $LCL[n] < N < UCL[n]$ (95% Confidence Limit), where LCL and UCL are given by:

$$LCL[n] = \frac{2n + 2.6^2 - \sqrt{(2.6^2 + 2n)^2 - 4(1 - 2.6^2 S_r^2)n^2}}{2(1 - 2.6^2 S_r^2)}$$

and

$$UCL[n] = \frac{2n + 1.8^2 + \sqrt{(1.8^2 + 2n)^2 - 4(1 - 1.8^2 S_r^2)n^2}}{2(1 - 1.8^2 S_r^2)}$$

NOTE: In these formulae the confidence level is expanded from 90% to 95%.

From these equations, the confidence limits accounting for both subjective microscopist and Poisson components for various fiber counts are calculated (Table 1) by taking $S_r = 0.2$. The intra- and inter-microscopist variability may be greater if quality control is poor.

Table 1. Intra-microscopist ($S_r=0.2$) 95% confidence interval bracketing the consensus mean for various numbers (n) of fibers in a single count

| Number (n) for fibers | Lower confidence limit (LCL) | Upper confidence limit (UCL) | Expanded uncertainty (%) |
|-----------------------|------------------------------|------------------------------|--------------------------|
| 5 | 1.6 | 13 | (-68;160) |
| 7 | 2.6 | 16 | (-63;129) |
| 10 | 4.2 | 21 | (-58;110) |
| 20 | 10 | 37 | (-50;85) |
| 50 | 29 | 85 | (-42;70) |
| 100 | 62 | 163 | (-38;63) |
| 200 | 127 | 319 | (-36;60) |

NOTE: Also shown is the confidence interval expressed as expanded uncertainty asymmetric around n and stated relative to n.

UNCERTAINTY BUDGET EXCLUDING COUNTING ERRORS

Various factors aside from counting errors can introduce random variation in measured values of asbestos concentrations [35]. Such factors are identified in Table 2.

Table 2. Example of an uncertainty budget for non-counting variable

| Variable | Estimated uncertainty | Uncertainty squared |
|--|-----------------------|---------------------|
| Sampling flowrate | 0.03 | 0.0008 |
| Sampling time | 0.02 | 0.0004 |
| Master stage micrometer | 0.01 | 0.0001 |
| Calibration of submaster | 0.01 | 0.0001 |
| Calibration of graticule | 0.02 | 0.0004 |
| Area of exposed filter | 0.05 | 0.0025 |
| Sum of squares | - | 0.0043 |
| Square root of sum of squares = Overall uncertainty | - | 0.066 |
| Expanded uncertainty (coverage factor $k = 2$) | - | 0.13 or 13 % |

The uncertainty in Table 2 contributes in quadrature to the expanded uncertainty. Therefore, as 13% is small relative to the values in Table 1, it may be reasonable to conclude that the contribution of non-counting errors to the total uncertainties is not significant in comparison to the Poisson and subjective errors.

NOTE 1: Non-counting errors are negligible only if consistently controlled.

NOTE 2: Inhomogeneous deposition of dust on the filter leads to gross errors, the magnitude of which cannot be estimated. Counting 20 or more fields ensures that minor divergence from randomness does not bias the result.

REFERENCES:

- [1] NIOSH [1979]. USPHS/NIOSH Membrane Filter Method for Evaluating Airborne Asbestos Fibers. By Leidel NA, Bayer SG, Zumwalde RD, Busch KA. Cincinnati, OH: U.S. Department of Health, Education, and Welfare, Center for Disease Control, National Institute for Occupational Safety and Health, DHEW (NIOSH) Publication No. 79-127.
- [2] Baron P, Pickford PA, Pickford GC [1986]. An asbestos sample filter clearing procedure. *Appl Ind Hyg* 1:169–171, 199.
- [3] LeGuen JMM, Galvin S [1981]. Clearing and mounting techniques for the evaluation of asbestos fibers by the membrane filter method. *Ann Occup Hyg* 24:273–280.
- [4] Lee EG, Pang TWS, Nelson J, Andrew M, Harper M [2011]. Comparison of mounting methods for the evaluation of fibers by phase contrast microscopy. *Ann Occup Hyg* 55:644–657.
- [5] OSHA [1994]. 29 CFR Part 1910.1001 Occupational Exposure to Asbestos. Washington, DC: U.S. Department of Labor, Occupational Safety and Health Administration.
- [6] McCrone W, McCrone L, Delly J [1978]. Polarized light microscopy. Ann Arbor, MI: Ann Arbor Science.
- [7] Rooker SJ, Vaughn NP, LeGuen JM [1982]. On the visibility of fibers by phase contrast microscopy. *Am Ind Hyg Assoc J* 43:505–515.
- [8] Kenney LC, Rood AP, Blight BJN [1987]. A direct measurement of the visibility of amosite asbestos fibres by phase contrast optical microscope. *Ann Occup Hyg* 33:261–264.

- [9] Harper M, Lee EG, Doorn SS, Hammond O [2008]. Differentiating non-asbestiform amphibole and amphibole asbestos by size characteristics. *J Occup Environ Hyg* 5:761–770.
- [10] Lee EG, Nelson J, Kashon M, Harper M [2015]. Evaluation of the dark-medium objective lens in counting asbestos fibers by phase-contrast microscopy. *Ann Occup Hyg* 59:616–628.
- [11] Baron P, Deye G [1990]. Electrostatic effects in asbestos sampling: parts I and II. *Am Ind Hyg Assoc J* 51:51–69.
- [12] ISO [2013]. ISO 13137-13 Workplace atmospheres -- Pumps for personal sampling of chemical and biological agents -- Requirements and test methods. Geneva, Switzerland: International Organization for Standardisation.
- [13] Johnston AM, Jones AD, Vincent JH [1982]. The influence of external aerodynamic factors on the measurement of the airborne concentration of asbestos fibers by the membrane filter method. *Ann Occup Hyg* 25:309–316.
- [14] Beckett ST [1980]. The effects of sampling practice on the measured concentration of airborne asbestos. *Ann Occup Hyg* 23:259–272.
- [15] Cherrie J, Jones AD, Johnston AM [1986]. The influence of fiber density on the assessment of fiber concentration using the membrane filter method. *Am Ind Hyg Assoc J* 47(8):465–474.
- [16] Lee EG, Nelson J, Hintz PJ, Joy G, Andrew ME, Harper M [2010]. Field performance of the CATHIA-T sampler and two cyclones against the standard cowled sampler for thoracic fiber concentrations. *Ann Occup Hyg* 54:545-556.
- [17] NIOSH [1977]. P&CAM 239. In: Taylor DG, ed. NIOSH manual of analytical methods, 2nd ed. Cincinnati, OH: U.S. Department of Health, Education, and Welfare, Center for Disease Control, National Institute for Occupational Safety and Health, DHEW(NIOSH) Publication No. 77-157-A.
- [18] AIA [1979]. AIA Health and Safety Recommended Technical Method #1: airborne asbestos fiber concentrations at workplaces by light microscopy. London, England: Asbestos International Association.
- [19] Crane D, Harper M [2011]. The phase-shift test slide.
https://www2.aiha.org/Registries/aar/Documents/Phase%20Shift%20Interpretation%20OSHA%20NIOSH_2011_04_11.pdf.
- [20] Abell MS, Shulman SA, Baron P [1989]. The quality of fiber count data. *Appl Ind Hyg* 4:273–285.
- [21] AIA [1983]. A study of the empirical precision of airborne asbestos concentration measurements in the workplace by the membrane filter method. Arlington, VA: Asbestos Information Association, Air Monitoring Committee.
- [22] NIOSH [1976]. Revised Recommended Asbestos Standard. Cincinnati, OH: U.S. Department of Health, Education, and Welfare, Center for Disease Control, National Institute for Occupational Safety and Health DHEW (NIOSH) Publication No. 77-169.
- [23] IOM [1982]. A comparison of the effects of different counting rules and aspect ratios on the level and reproducibility of asbestos fiber counts. Part I: effects on level and Part II: effects on reproducibility. By Crawford NP, Thorpe HL, Alexander W. Edinburgh, Scotland: Institute of Occupational Medicine.
- [24] HSE [1982]. Health and Safety Executive research paper 18: the reproducibility of fiber counts. By Ogden TL. Sheffield, England: Health and Safety Laboratory, Health and Safety Executive.

- [25] Schlecht PC, Schulman SA [1986]. Performance of asbestos fiber counting laboratories in the NIOSH Proficiency Analytical Testing (PAT) Program. *Am Ind Hyg Assoc J* 47:259–266.
- [26] Edwards GH, Lynch JR [1968]. The method used by the Public Health Service, for enumeration of asbestos dust on membrane filters. *Ann Occup Hyg* 11:1-6.
- [27] Lane RE, Barnes JM, Roach SA, Smith S, Addingley CG, Holmes S, Hunt R, Knox JF, King E [1968]. Hygiene standard for chrysotile asbestos dust. *Ann Occup Hyg* 11:47 -49.
- [28] NIOSH [1972]. NIOSH criteria for a recommended standard: occupational exposure to asbestos. Cincinnati, OH: U.S. Department of Health Education and Welfare, Center for Disease Control, National Institute for Occupational Safety and Health, DHEW (NIOSH) Publication No. 72-10267.
- [29] Royal Commission on Matters of Health and Safety Arising from the Use of Asbestos in Ontario. Measurement of asbestos fiber concentrations in workplace atmospheres: Study No. 9. By Chatfield, EJ. Toronto, Ontario.
- [30] Walton WH [1982]. The nature, hazards, and assessment of occupational exposure to airborne asbestos dust: a review. *Ann Occup Hyg* 25:115–247.
- [31] LeGuen JMM, Ogden TL, Shenton-Taylor T [1984]. The phase-shift test slide. *Ann Occup Hyg* 28:237-247.
- [32] Taylor DG, Baron PA, Shulman SA, Carter JW [1984]. Identification and counting of asbestos fibers. *Am Ind Hyg Assoc J* 45:84–88.
- [33] Pang TWS, Harper M [2008]. The quality of fiber counts using improved slides with relocatable fields. *J Environ Monit* 10:89-95.
- [34] Harper M, Slaven JE, Pang TWS [2009]. Continued participation in an asbestos fiber counting proficiency test with relocatable grid slides. *J Environ Monit* 11:434-438.
- [35] ISO [2014]. ISO 8672-14[E] Air quality — determination of the number concentration of airborne inorganic fibres by phase contrast optical microscopy — membrane filter method. Geneva, Switzerland: International Organization for Standardisation.
- [36] Baron PA, Shulman SA [1987]. Evaluation of the Magiscan image analyzer for asbestos fiber counting. *Am Ind Hyg Assoc J* 48:39-46.
- [37] Pang TWS [2000]. Precision and accuracy of asbestos fiber counting by phase contrast microscopy. *Am Ind Hyg Assoc J* 61:529–538.
- [38] Harper M, Bartolucci A [2003]. Preparation and examination of proposed consensus reference standards for fiber-counting. *Am Ind Hyg Assoc J* 64:283-287.
- [39] WHO [1985]. Reference methods for measuring airborne man-made mineral fibers (MMMMF). By: The WHO/EURO Technical Committee for Monitoring and Evaluating Airborne MMMF. Copenhagen, Denmark: World Health Organization.
- [40] NIOSH [1977]. NIOSH criteria for a recommended standard: occupational exposure to fibrous glass. Cincinnati, OH: U.S. Department of Health, Education, and Welfare, Center for Disease Control, National Institute for Occupational Safety and Health, DHEW (NIOSH) Publication No. 77-152.

METHOD WRITTEN BY:

Paul A. Baron, PhD, NIOSH; Revised by Martin Harper, PhD, CIH, FAIHA, CChem, FRSC, NIOSH (retired) and Rosa Key-Schwartz, PhD, NIOSH.

Disclaimer: Mention of any company or product does not constitute endorsement by the National Institute for Occupational Safety and Health, Centers for Disease Control and Prevention. In addition, citations to websites external to NIOSH do not constitute NIOSH endorsement of the sponsoring organizations or their programs or products. Furthermore, NIOSH is not responsible for the content of these websites. All web addresses referenced in this document were accessible as of the publication date.

Table 3. CAS numbers for analytes

| Name | CAS No. |
|---------------------------|---------------|
| Actinolite | [77536-66-4] |
| Ferroactinolite | [15669-07-5] |
| Amosite | [12172-73-5] |
| Anthophyllite | [77536-67-5] |
| Chrysotile | [12001-29-5] |
| Crocidolite | [12001-28-4] |
| Tremolite | [77536-68-6] |
| Amphibole asbestos | [1332-21-4] |
| Refractory ceramic fibers | [142844-00-6] |
| Fibrous glass | [14808-60-7] |

APPENDIX A: CALIBRATION OF THE GRATICULE

Before ordering any graticule, the following calibration must be done to obtain a counting area (D) 100 µm in diameter at the image plane. The diameter, d_c (mm), of the circular counting area and the disc diameter must be specified when ordering the graticule.

1. Insert any available graticule into the eyepiece and focus so that the graticule lines are sharp and clear.
2. Set the appropriate inter-pupillary distance and, if applicable, reset the binocular head adjustment so that the magnification remains constant.
3. Install the 40x to 45x phase objective.
4. Place a stage micrometer on the microscope object stage and focus the microscope on the graduated lines.
5. Measure the magnified grid length of the graticule, L_o (µm), using the stage micrometer.
6. Remove the graticule from the microscope and measure its actual grid length, L_a (mm). This can best be accomplished by using a stage fitted with verniers.
7. Calculate the circle diameter, d_c (mm), for the Walton-Beckett graticule: $d_c = \frac{L_a}{L_o} \times D$
EXAMPLE: if $L_o = 112$ µm, $L_a = 4.5$ mm, and $D = 100$ µm, then $d_c = 4.02$ mm.
8. Check the field diameter, D (acceptable range 100 µm ± 2 µm) with a stage micrometer upon receipt of the graticule from the manufacturer. Determine field area (acceptable range 0.00754 mm² to 0.00817 mm²).

APPENDIX B: DETERMINATION OF A MICROSCOPIST'S ABILITY TO OBSERVE, MEASURE AND COUNT FIBERS USING RELOCATABLE GRIDDED COVERSLEIPS (Non-mandatory)

1. Reference slides are commercially available, made from chrysotile or amosite proficiency test filters obtained from the Industrial Hygiene Proficiency Analytical Testing (IHPAT) scheme of the American Industrial Hygiene Association Proficiency Analytical Testing, LLC [37]. Each slide has been mounted

with a permanent Euparal medium and covered with a relocatable gridded cover slip. The fibers visible in each grid opening have been identified and their locations marked on a drawing of each opening. The identity, number and position of each fiber have been verified by a second microscopist. The accuracy of this verification has been shown to be within 3% of consensus values determined by multiple microscopists, separately and together [38]. Such slides are referred to in this method as standard relocatable test slides, and they are applied in various ways to improve and assess the quality of fiber counts.

NOTE: It is also possible to make standard relocatable test slides in the laboratory from PAT or field samples by using commercially available relocatable gridded cover slips. Either filter clearance or slide mounting procedure can be used with these cover-slips, but the DMF/acetic acid-Euparal procedure has been demonstrated to provide slides with long-term stability. The fibers in each grid are identified, marked and verified by at least two microscopists as above.

- Count the fibers in each designated field and refer the counts to the accompanying slide descriptions. Calculate a score from the number of absolute discrepancies between the reported and verified fibers in each field as shown in:

$$Score = \left(1 - \left(\frac{\text{number of discrepancies}}{\text{number of verified fibers}}\right)\right) \times 100$$

- Microscopists shall obtain a discrepancy score of more than 70 for a slide containing amosite fibers and more than 50 for a slide containing chrysotile fibers from the AIHA IHPAT scheme (or more than 70 for a slide prepared from chrysotile field samples) before proceeding. These scoring criteria are based on the results that have been achieved in round-robin studies and proficiency test programs. If these scores are not achieved, the Quality Assurance Officer is expected to work with the microscopist to review the slide descriptions to determine the cause and then attempt to rectify the situation by having the microscopist repeat the microscope set-up or by re-training.

NOTE: The number of absolute discrepancies has been shown to be linearly related to the sum of counting errors [37]. The positive discrepancies are mainly due to sizing extra fibers (especially amphiboles). The negative discrepancies are mainly due to oversight of fibers (especially chrysotile). Chrysotile filters from the AIHA IHPAT program contain a large number of fibers with narrow widths near the limit of detection and thus provide a very robust test of visual acuity and concentration. In theory, it should be possible for microscopists to obtain high discrepancy scores using slides made from chrysotile PAT samples, but a discrepancy score above 50 is sufficient to ensure the microscopist will be able to see the majority of the wider fibers typical of field samples.

- The repeated fiber counts obtained from standard relocatable test slides can be used to document the laboratory's precision for each microscopist, per step 13. If repeated counts from specific fields are used, the resulting intra- and inter-microscopist precision will be improved because there will not be a contribution from the selection of field areas to be counted.

APPENDIX C: COMPARISON OF COUNTING RULES

Figure 2 shows a Walton-Beckett graticule as seen through the microscope. This is a Type G22 graticule with 3:1 ratios, providing optimal assistance for these counting rules. The rules will be discussed as they apply to the labeled objects in the figure.

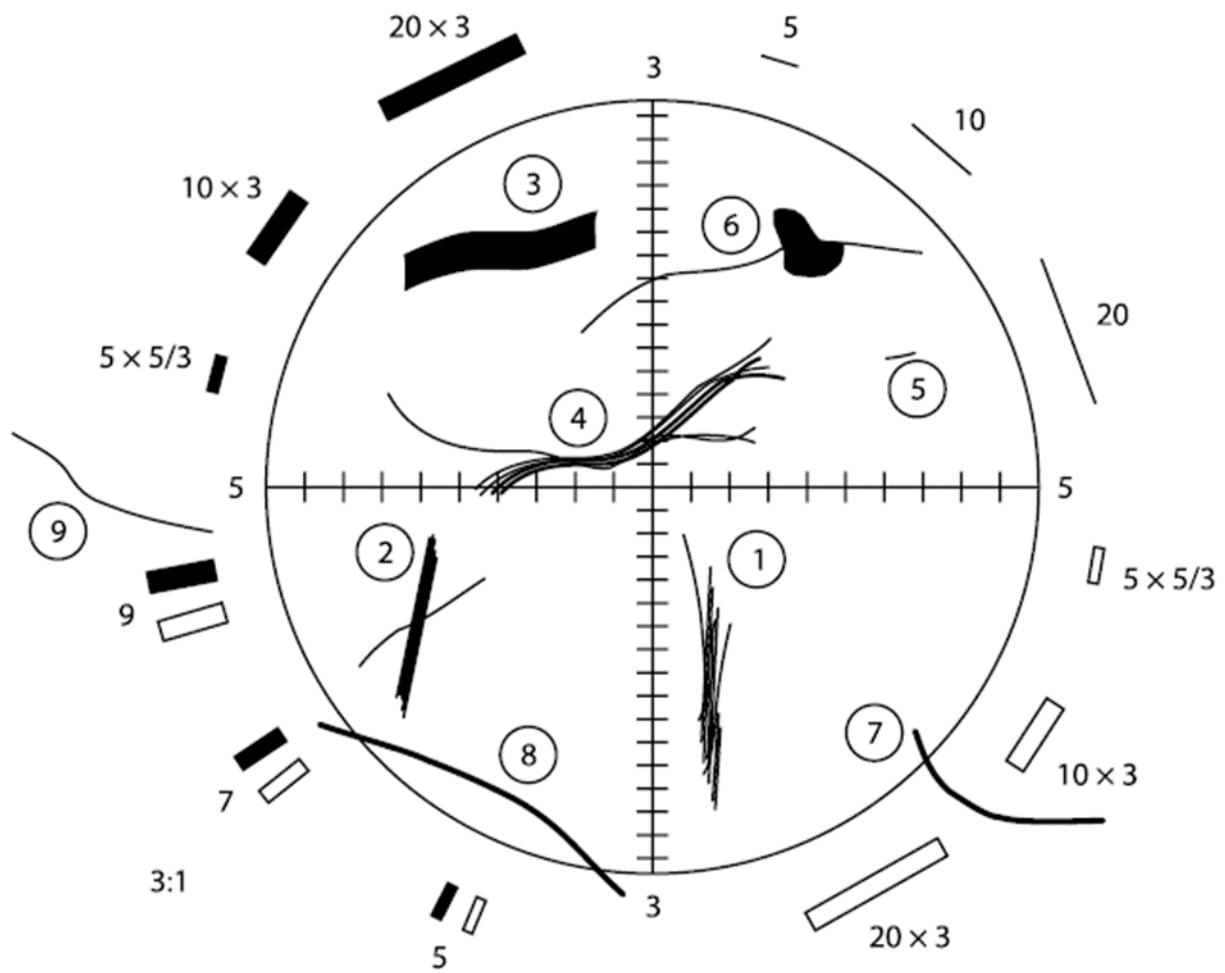

Figure 2 Walton-Beckett graticule with fibers

These rules are sometimes referred to as the “A” rules:

| Object | Count | Discussion |
|---------------|--------------|---|
| 1 | 1 fiber | Optically observable asbestos fibers are actually bundles of fine fibrils. If the fibrils seem to be from the same bundle, the object is counted as a single fiber. Note, however, that all objects meeting length and aspect ratio criteria are counted whether or not they appear to be asbestos. |
| 2 | 2 fibers | If fibers meeting the length and aspect ratio criteria (length >5 µm and length-to-width ratio > 3 to 1) overlap, but do not seem to be part of the same bundle, they are counted as separate fibers. |
| 3 | 1 fiber | Although the object has a relatively large diameter (>3 µm), it is counted as a fiber under the rules. There is no upper limit on the fiber diameter in the counting rules. Note that fiber width is measured at the widest compact section of the object. |
| 4 | 1 fiber | Although long fine fibrils may extend from the body of a fiber, these fibrils are considered part of the fiber if they seem to have originally been part of the bundle. |
| 5 | Do not count | If the object is ≤ 5 µm long, it is not counted |
| 6 | 1 fiber | A fiber partially obscured by a particle is counted as one fiber. If the fiber ends emanating from a particle do not seem to be from the same fiber and each end meets the length and aspect ratio criteria, they are counted as separate fibers. |
| 7 | ½ fiber | A fiber which crosses into the graticule area one time is counted as ½ fiber. |
| 8 | Do not count | Ignore fibers that cross the graticule boundary more than once. |
| 9 | Do not count | Ignore fibers that lie outside the graticule boundary. |

NOTE 1: OSHA Method ID-160 has slightly different counting rules, e.g. Rule 5: If the object is $\leq 5 \mu\text{m}$, it is not counted, would become: If the object is $< 5 \mu\text{m}$, it is not counted. In practice, these minor differences would not likely modify calculated concentrations to the extent that decisions based on those concentrations would be affected, but this opinion has not been tested.

NOTE 2: Fibers wider than $3 \mu\text{m}$ are included in this method. Some other methods for counting asbestos fibers restrict the count to only those fibers of $3 \mu\text{m}$ width or less, as these are the fibers most likely to penetrate to the bronchial and lower airways. However, the inlet efficiency of the cowl has a similar effect in that it limits the maximum diameter of fibers entering the cassette, so the effect of this additional dimensional counting rule on the total fiber count is expected to be small. Any bias from not applying an upper width limit is also conservative (i.e. concentrations will be assessed higher).

APPENDIX D: ALTERNATE COUNTING RULES FOR NON-ASBESTOS FIBERS

Other counting rules may be more appropriate for measurement of specific non-asbestos fiber types, such as fibrous glass. These include the rules given below ("B" rules from NIOSH Method 7400, Revision #2, dated 08/15/1987), the World Health Organization reference method for man-made mineral fiber [39], and the NIOSH fibrous glass criteria document method [40]. The upper diameter limit in these methods prevents measurements of non-thoracic fibers. It is important to note that the aspect ratio limits included in these methods vary. Graticules designed for counting according to these rules are available (e.g. Walton-Beckett Type G24).

OSHA recommends using these alternate, or "B" counting rules as given below for all man-made vitreous fibers (MMVF). It is emphasized that hybridization of different sets of counting rules is not permitted. Report specifically which set of counting rules are used with the analytical results.

"B" Counting Rules

1. Count only *ends* of fibers. Each fiber must be longer than $5 \mu\text{m}$ and less than $3 \mu\text{m}$ diameter.
2. Count only ends of fibers with a length-to-width ratio equal to or greater than 5:1.
3. Count each fiber end which falls within the graticule area as one end, provided that the fiber meets rules 1 and 2 above. Add split ends to the count as appropriate if the split fiber segment also meets the criteria of rules 1 and 2 above.
4. Count visibly free ends which meet rules 1 and 2 above when the fiber appears to be attached to another particle, regardless of the size of the other particle. Count the end of a fiber obscured by another particle if the particle covering the fiber end is less than $3 \mu\text{m}$ in diameter.
5. Count free ends of fibers emanating from large clumps and bundles up to a maximum of 10 ends (5 fibers), provided that each segment meets rules 1 and 2 above.
6. Count enough graticule fields to yield 200 ends. Count a minimum of 20 graticule fields. Stop at 100 graticule fields, regardless of count.
7. Divide total end count by 2 to yield fiber count.

APPENDIX E: EQUIVALENT LIMITS OF DETECTION AND QUANTITATION

| Fiber density on filter* (Fibers per 100 fields) | Fiber density on filter* (Fibers /mm ²) | Fiber concentration in air, f/cc (400-L air sample) | Fiber concentration in air, f/cc (1000-L air sample) |
|---|--|---|--|
| 200 | 255 | 0.25 | 0.10 |
| 100 | 127 | 0.125 | 0.05 |
| LOQ 80 | 102 | 0.10 | 0.04 |
| 50 | 64 | 0.0625 | 0.025 |
| 25 | 32 | 0.03 | 0.0125 |
| 20 | 25 | 0.025 | 0.010 |
| 10 | 12.7 | 0.0125 | 0.005 |
| 8 | 10.2 | 0.010 | 0.004 |
| LOD 5.5 | 7 | 0.00675 | 0.0027 |

*Assumes 385 mm² effective filter collection area, and field area = 0.00785 mm², for relatively “clean” (little particulate aside from fibers) filters

APPENDIX F: P&CAM 239 ASBESTOS FIBER IN AIR [17]

| | |
|--|---|
| Analyte: Asbestos fibers | Method No.: P&CAM 239 |
| Matrix: Air | Range: 0.1-60 fibers/cm ³ |
| Procedure: Filter collection, microscopic count | Precision (CV_T): 0.24 to 0.38 |
| Date Issued: 3/30/77 | Classification: D (Operational) |

1. Principle of the Method

- 1.1. This method describes the equipment and procedures for collecting, mounting, and counting asbestos fibers on cellulose ester membrane filters in the evaluation of personal samples of airborne asbestos fibers. The purpose of the method is to determine an employee's index of exposure to airborne asbestos fibers. The method is primarily a personal monitoring technique, but can be used for area monitoring.
- 1.2. The sample is collected by drawing air through a membrane filter by means of a battery powered personal sampling pump. The filter is transformed from an opaque solid membrane to a transparent optically homogeneous gel. The fibers are sized and counted using a phase-contrast microscope at 400-450X magnification.
- 1.3. Definitions. Asbestos fiber, for counting purposes, means a particulate which has a physical dimension longer than 5 micrometers and with a length to diameter ratio of 3 to 1 or greater. Asbestos includes chrysotile, cummingtonite-grunerite (amosite), crocidolite, fibrous tremolite, fibrous anthophyllite, and fibrous actinolite.
- 1.4. Any laboratory attempting to use this procedure should have at least one counter attend a training course conducted by an experienced, proficient laboratory. Novice, untutored counters, using only published instructions, can easily obtain counts of half those performed by experienced, proficient counters. Large differences between laboratories can be caused by: 1) differences in technique and observing ability among counters and 2) small, but significant, differences between microscopes meeting the basic specifications of Section 6.2. The following procedures are recommended:

- 1.4.1. All microscopists who perform asbestos counting should meet together for an "asbestos counting workshop" at least quarterly. This is best accomplished with counters from several laboratories using their own microscopes.
- 1.4.2. Each microscopist should count the same series of slides and with the results being compared.
- 1.4.3. Differences between counters should be resolved with side-by-side counting of the fields by the different counters.
- 1.4.4. Individuals who are found to be persistent outliers over several sessions should be encouraged to seek other tasks in their respective laboratories.

2. Range and Sensitivity

- 2.1. The usable range is primarily a function of sample volume, microscope count field area, and background airborne particulates. The influence of these variables is discussed in 8.1.3. For a microscope count field area of 0.003 mm^2 (see Figure 1) and a pump flow rate of 1.7 lpm, the optimal fiber densities would be produced over the range of 0.4 fiber/cm³ (8-hour sample) to about 60 fibers/cm³ (15-minute sample). For a field area of 0.006 mm^2 (see Figure 2) and a pump flow rate of 1.7 lpm, the optimal range is 0.2 fiber/cm³ (8-hour sample) to about 30 fibers/cm³ (15-minute sample). In each case, the optimal detection limits are inversely proportional to pump flow rate. The upper detection limit can be extended by using sample times less than 15 minutes or using lower flow rates. The lower detection limit can be extended by increasing the flow rate up to about 2.5 lpm. Filter surface fiber densities less than optimal (less than about 0.5 to 1.0 fiber per count field) are still adequate, but will lead to decreased precision for the method (increased coefficient of variation, see Section 4). The minimum total fiber count in 100 fields considered adequate for reliable quantitation is 10 fibers. Thus, the lower limit of reliable quantitation is 0.1 fiber/cm³ (100,000 fibers/m³). For this level, a flow rate of about 2.5 lpm is recommended. For a field area of 0.003 mm^2 , the minimum sample time would be about 2 hours. For a field area of 0.006 mm^2 , the minimum sample time would be about 1 hour.
- 2.2. This method considers only fibers with a length to diameter ratio of 3 to 1 or greater and a length greater than 5 micrometers.

3. Interferences

In an atmosphere known to contain asbestos, all particulates with a length to diameter ratio of 3 to 1 or greater, and a length greater than 5 micrometers should, in the absence of other information, be considered to be asbestos fibers and counted as such.

4. Precision and Accuracy

- 4.1. In the past decade, there have appeared a number of articles examining sources of variation in the asbestos sampling and counting procedure. These include: Lynch et al. (11.1), Weidner and Ayer (11.2), Conway and Holland (11.3), Leidel and Busch (11.4), Beckett and Attfield (11.5), and Rajhans and Bragg (11.6). The sources of variation will be discussed by stages in the membrane filter evaluation procedure.
- 4.2. **Sources of Variation in the Sampling Process.** These include variations in pump flow rate, proximity of the filter to the employee's body, and filter location (left to right) in the employee's breathing zone.
 - 4.2.1. Section 9.1 requires that the personal sampling pump be calibrated with sufficient accuracy such that the 95% confidence limits on the flow rate are $\pm 10\%$. This is equivalent to a coefficient of variation (CV) of about 5%. However, this CV makes a negligible contribution to the total CV for the method due to the relatively large CV of the counting procedure.
 - 4.2.2. Conway and Holland (11.3) concluded that positioning of the filter cassette on the wearer (regarding the angular portions of the filter and their proximity to the wearer) is not a significant factor in determining the fiber distribution on filters.
 - 4.2.3. Weidner and Ayer (11.2) concluded that there is no appreciable difference between samples collected on either the right or left sides of a breathing zone or between samples collected side-by-side, especially for samples with concentrations less than 2.5 fibers/cm³.

4.3. Sources of Variation in the Counting Procedure

4.3.1. Random variations exist in the fiber distribution on a filter wedge (intra-wedge variability). The industrial hygiene literature has seen considerable debate in the last 20 years concerning whether or not the distribution of mineral dust or asbestos fibers on a filter surface is adequately described by a Poisson distribution probability density function. Leidel and Busch (11.4) found excellent agreement between empirical error variance and theoretical variance calculated from the assumption of Poisson distributed true counts. They concluded that there was not excessive variation among count fields for a filter wedge and that clumping of fibers (non-random coalescence) did not occur.

4.3.2. Variations exist in the fiber distribution on the total filter surface (inter-wedge variability) due to the random or non-random distribution of fibers across the total surface of the filter. This type of variation is easily confused with intra-wedge variations. The count procedure does not require counting of multiple sectors of the filter. There may be significant differences between average counts for different wedges, or the fiber distribution variations for the total filter surface may be greater than the variations of the Poisson distribution. If either of these occur experimentally, one must use the experimental variations to estimate the minimum precision of the count procedure. The minimum precision is governed by the variations of the fiber distribution on the total surface of the filter.

Conway and Holhind (11.3) concluded the distribution of fibers on filters is not uniform and, the distribution of fiber counts is more disperse than Poisson. For their filters which had significant variations in fiber concentrations between sectors (as much as 50-60% of the total filter mean), they described the following relation for the standard deviation of the total number of fibers counted on a wedge (N)

$$\text{empirical } s(N) = 1.6(N)^{1/2}$$

where N is about 100. The Poisson standard deviation would be:

$$\text{Poisson } \sigma(N) = (N)^{1/2}$$

Rajhans and Bragg (11.6) in Series I of their study found significant variation between filter segments and rejected the Poisson distribution for the total filter surface. However, in Series II of their study, utilizing various experimental modifications, they found no significant variation between filter segments and no reason to reject the assumption of Poisson distributed fiber counts.

4.3.3. Systematic variations due to differences between microscopes were studied by Leidel and Busch (11.4). In their study using five different brands of microscopes, they found no significant differences among four, but the fifth gave counts approximately 45% higher on the average than the other four.

4.3.4. Variations due to differences between counters should be examined at three levels: experienced counters occasionally counting, experienced counters routinely counting, and inexperienced (new or untutored) counters. Leidel and Busch (11.4) studied five experienced counters, with one counting only occasionally. There were no significant differences among three of the counters, but a fourth was 16% lower than the first three. The fifth, who occasionally counted, averaged 27% higher than the first three. Conway and Holland (11.3) studied three experienced counters and three inexperienced counters. They found statistically significant differences between the means of both the experienced and inexperienced counters that typically were in the range plus or minus 5 to 15%. They concluded that experience as a fiber counter is not a significant parameter affecting intercounter variations. Rajhans and Bragg (11.6) found no significant differences among means of five experienced counters in Series I of their study. But in their carefully controlled Series II, an analysis of variance showed significant variations between counters that were plus or minus 1 to 15%.

4.3.5. Variations between laboratories are most likely due to systematic biases and are not a significant additional source of random variations. Any additional variations are most likely due to differences in counting technique. Beckett and Attfield (11.5) observed that standard

counters improved greatly after personal instruction; also new counters, after instruction, tended to overcompensate and get exceedingly high counts. Additionally, they found that counts from an experienced laboratory that had not had contact with other laboratories performing the same analysis were as far from the standard values as were the counts by new counters.

- 4.4. Sources of variations between samples taken at different times on one employee during one work shift can affect the exposure estimate for that employee. These are primarily due to a) differences in exposure concentrations during the day, b) differences in location of the employee within the plant, and c) differences in work operation performed by the employee during the day. These sources of variation can be controlled by proper choice of sampling strategy. Refer to Leidel and Busch (11.7) and Leidel, Busch, and Lynch (11.8) for an extended discussion of sampling strategies. Interday temporal variations can affect the exposure estimates obtained on different days. Refer to Leidel, Busch, and Crouse (11.9) for a discussion of this type of variation.
- 4.5. Until recently, the total coefficient of variation (CV_T) for the sampling and counting procedure was best estimated from the work of Conway and Holland (11.3). The conclusions of their study included:
 - 4.5.1. The precision of their procedure for filters not containing an abundance of fine fibers can be estimated by a coefficient of variation of 16.2%. This value includes variation among counters and observed interaction effects.
 - 4.5.2. The accuracy of the procedure for similar filters may be estimated for a 100-fiber count by a coefficient of variation of 21.4%. This assumes that the contribution of the overall variance from the nonuniform fiber distribution is additive.
 - 4.5.3. A high percentage of very fine fibers on the filter can significantly affect the standard deviation and confidence limits for counts by different counters. After combining variations in fiber concentrations over the entire filter with those for different counters, it was concluded:
 1. For filters with a low concentration of fine fibers, the coefficient of variation is estimated at 21% and the 95% confidence interval is $\pm 43\%$.
 2. For filters with a high concentration of fine fibers, the coefficient of variation is estimated at 25% and the 95% confidence interval is $\pm 50\%$.

Lynch, Kronoveter, and Leidel (11.1) have also reported on variations of the method. Their intralaboratory study utilized the data from a large number of dust counts made by different methods by experienced counters over a period of years in an epidemiologic study of the asbestos products industry. They concluded that the standard deviation of counts of fibers longer than 5 micrometers on membrane filters could be estimated from the relation $\sigma = (N)^{0.591}$. Thus for counts of about 100 fibers, the coefficient of variation could be estimated at about 15.2% and the 95% confidence limits at $\pm 30.4\%$.

These values are lower than the values reported by Conway and Holland (11.3). Recently, the Johns-Manville Corporation conducted an in-house investigation of the asbestos count method. (11.10). The study data contained total fiber counts for over 100 filters with each filter counted by two to five counters. From the Johns-Manville data, NIOSH calculated over 100 estimates of the count CV for the method (11.11). The NIOSH CV estimates included random intrafilter variations and intercounter variations, but did not include random pump flow rate variations. It was found that the count coefficient of variation (all random variations except for pump variations) was a function of the total fiber count. NIOSH then included a CV of 0.05 for random pump variations (see Section 9.1) in the CV-estimator equation to obtain a CV_T -estimator. The CV_T -estimator line is plotted on Figure 3 for total fiber counts in the range 10 to 100 fibers. Or the following equation can be used: $CV_T = [\text{antilog}_{10}(-0.215 - 0.203(\log_{10} FB)) + 0.0025]^2$ where FB is total fiber count as discussed in Section 10.

Figure 3 demonstrates that for a total fiber count of 100, the best CV_T is attainable with the appropriate sampling times given in 8.1.3 and the count rules in 8.3.9. When making

decisions regarding compliance with the OSHA asbestos exposure standards in 29 CFR 1910.1001, the statistical procedures given in Leidel et al. (11.11) should be followed. The procedures are based on statistical theory and assumptions given in References 11.12, 11.13.

Because of the possibility of systematic biases due to differences between microscopes, counters, and laboratories as discussed above, it is strongly recommended that any laboratory counting asbestos should participate in an interlaboratory quality control program that includes the counting of standard reference filters. These standard filters are available from NIOSH through the Proficiency Analytical Testing (PAT) Program. The PAT Program is used by the American Industrial Hygiene Association (AIHA) as part of its Laboratory Accreditation Program. Each laboratory's quality control program must include protocols for routinely adjusting, and calibrating sampling and counting equipment plus training and evaluation programs for counters.

5. **Advantages and Disadvantages of the Method**

- 5.1. The method is intended to give an index of employee exposure to airborne asbestos fibers of specified dimensional characteristics.
- 5.2. It is not meant to count all asbestos fibers in all size ranges or to differentiate asbestos from other fibrous particulates.

6. **Apparatus**

6.1. Sampling Equipment

The personal sampling equipment train consists of 1) personal sampling pump, 2) tubing, 3) clothing spring clip, 4) tubing-to-field monitor metal adaptor, and 5) field monitor (filter and holder).

- 6.1.1. Personal Sampling Pump. The pump must be capable of sampling at 1.0 to 2.5 liters per minute (lpm) against a flow resistance of 7.5 inches of water (1.4 mm Hg) for 8 continuous hours on a fully charged battery.
- 6.1.2. Tubing. Laboratory tubing such as rubber or plastic with 6-mm bore and about 100 cm length.
- 6.1.3. Clothing Spring Clip. The clip attaches the rubber tubing to the lapel or shirt of the individual being monitored.
- 6.1.4. Tubing-to-field Monitor Adaptor. A short metal adaptor with ridges on one end to grip the inside of the tubing. The other end is designed for a pressure fit into the field monitor.
- 6.1.5. Field Monitor (Filter and Holder). The only field monitor currently considered acceptable by NIOSH is manufactured by the Millipore Corporation. The unit consists of 1) a three section styrene plastic case designated Millipore Aerosol Monitor Case, 2) a 37-mm diameter plain white cellulose ester membrane filter designated Millipore AA (pore size of 0.8 micrometer), 3) a support pad, and 4) two plastic sealing caps. If a large number of samples are to be taken, it may be less expensive to reuse the plastic cases. Great care must be taken in the cleaning and reassembly process. The outside mating surfaces of the field monitors may be covered with a "shrink-fit" band to provide proper sealing and a writing surface for filter identification.

6.2. **Optical Equipment and Microscope Features**

- 6.2.1. Microscope body with binocular head.
- 6.2.2. 10X Huygenian eyepieces are recommended. Other eyepieces can be substituted if necessary. Wide field eyepieces can be used; however, wide field eyepieces may yield a count field area less than 0.003 mm² with the Porton reticle. This is not always desirable from the standpoint of obtaining optimum sampling times (see Section 8.1.3). If wide field eyepieces are used, it is preferable to use the Patterson Globe and Circle reticle to obtain a larger count field area.
- 6.2.3. Koehler illumination (preferably built-in with provisions for adjusting light intensity).
- 6.2.4. A Porton reticle is recommended. Others such as the Patterson Globe and Circle can be substituted.
- 6.2.5. Mechanical stage.

- 6.2.6. Phase-Contrast condenser with a numerical aperture (N.A.) equal to or greater than the N.A. of the objective.
- 6.2.7. 40-45X phase contrast achromatic objective (N.A. 0.65 to 0.75).
- 6.2.8. Phase-ring centering telescope or Bertrand lens.
- 6.2.9. Green or blue filter, if recommended by microscope manufacturer.
- 6.2.10. Stage micrometer with 0.01 mm subdivisions.
- 6.2.11. For general guidance on phase contrast microscopy, consult Needham (11.12), Clark (11.15) and McCrone (11.14).

6.3. **Filter Mounting Equipment.** Experience has shown that certain equipment is useful for efficient sample mounting. The following items are recommended for extracting and mounting a portion of the filter for counting.

- 6.3.1. Microscope slides. 2.5 by 7.5 cm glass slides are most commonly used. Sample number, data, initials, etc., can be conveniently written on a frosted endslide.
- 6.3.2. Cover Slips. Cover slips are a necessary part of the slide mount and optical system. The shape should be appropriate for the size of the filter wedge. The appropriate cover slip depends upon the objective to be used. Ordinarily, objectives are optically corrected for a #1½ (0.17 millimeter) thickness cover slip. Improper cover glass thickness will detract from the final image quality.
- 6.3.3. Scalpel. A scalpel is needed to cut out a portion of the filter to be examined. A number-ten curved blade scalpel is recommended.
- 6.3.4. Tweezers. A pair of fine-tipped tweezers is used to remove the membrane filter slice from the field monitor and place it upon the slide.
- 6.3.5. Lens Tissue. To insure cleanliness, a lint-free tissue is recommended. This tissue should also be used for wiping mounting tools and for cleaning slides and coverslips.
- 6.3.6. Glass Rod. A fire-polished glass rod may be used to spread the mounting solution on the slide.
- 6.3.7. Wheaton Balsam Bottle. This special glass container has a glass top which prevents contamination of the mounting solution. A glass rod is included for dispensing the solution.

7. Reagents

Chemicals should be reagent grade, free from particles and color, conforming to the specifications of the Committee on Analytical Reagents of the American Chemical Society, where such specifications are available.

- 7.1. Dimethyl phthalate
- 7.2. Diethyl oxalate

Avoid getting the mounting solution on the skin. Wash skin promptly with soap and water if skin contact occurs.

8. Procedure

8.1. Sampling

8.1.1. General Information

Guidelines for the monitoring of employee exposures to industrial atmospheres are given in Reference 11.8. The Federal requirements for monitoring employee exposure to airborne asbestos are found in 29 CFR 1910.1001.

8.1.2. Mounting the Sampling Pump on the Worker

Fasten the sampling pump to the worker's belt and fasten the field monitor to the lapel or shirt front (as close to the breathing zone as is practical). Remove the top cover of the plastic monitor, then invert the monitor making certain the exposed filter is facing downward. Turn the pump on and adjust to the calibrated flow rate (1.0 to 2.5 lpm). Record the following information in a logbook.

- 1. Filter number
- 2. Pump start time and date
- 3. Flow rate
- 4. Subject's name and job title

5. Type of operation or process
6. Ventilation controls and is the worker wearing a respirator approved for asbestos?
The pump should be checked periodically during the sampling period for proper operation and flow rate.

8.1.3. Optimum Sampling Times

The requirement for the minimum count of 100 fibers or 20 fields in 8.3.9 was determined to be the best compromise to achieve adequate precision for the airborne fiber estimate and reasonable counting times. An optimum fiber density of about 1 to 5 fibers per microscope count field is recommended. To estimate appropriate sampling times for feasible counting and optimal counting, one must consider the following constraints:

1. microscope count field area (generally 0.003 to 0.006 mm²)
2. pump flow rate (typically 2.5 lpm maximum)
3. average airborne fiber concentrations
4. counting rule range of 20 to 100 fields
5. adequate fiber density to obtain a minimum count of 10 fibers in 100 fields, which is the least total fiber count that yields an acceptable count precision
6. background airborne particulate levels that can reduce the count precision due to an obscuring of fibers on the filter surface

The preceding constraints were considered in drawing Figures 1 and 2. These figures were developed from the following relationship:

$$\text{sampling time} = \frac{\left(\frac{FB}{FL}\right) \left(\frac{ECA}{MFA}\right)}{(FR)(AC)(1000)} \text{ minutes}$$

where:

FB/FL = 1 to 5 fibers/field

ECA = effective collecting area of filters (855 mm² for 37-mm filter with effective diameter of 33 mm)

MFA = microscope field area (generally 0.003 to 0.006 mm²)

FR = Pump flow rate (generally 1.0 to 2.5 lpm)

AC = Air concentration of fibers in fibers/cm³.

Figure 1 (microscope field area = 0.003 mm²) and Figure 2 (microscope field area = 0.006 mm²) show optimum and feasible sampling times for a pump flow rate of 1.7 lpm. Each individual responsible for sampling asbestos should prepare a similar chart for his particular pump flow rate and microscope field area before sampling is performed to aid in estimating proper sampling times. On Figures 1 and 2, the areas with solid shading lines are generally the optimum conditions for counting. The broken shading lines are for conditions very close to optimal.

However, feasible counting conditions may extend down to about 0.1 fiber/field and above 5 fibers/field. Recommended sampling times are most strongly influenced by background airborne particulate levels, once all the other constraints have been estimated. For heavy particulate levels, it may be necessary to limit each filter to about 60 to 180 minutes sampling duration. Each individual responsible for sampling should work closely with the microscopist to attain as high as possible filter surface fiber densities (up to about 5 fibers/field), while avoiding filter surface background particulate levels that create very difficult or impossible counting conditions. If one has very little idea of airborne fiber and particulate levels, the best procedure is to take several long samples (as one 8-hour or two consecutive 4-hour samples) in conjunction with several short samples (as four consecutive 2-hour or eight consecutive 1-hour samples). If the longer samples prove very difficult to count, the microscopist will have the shorter samples to fall back on.

From Figures 1 and 2, it can be seen that there are certain sampling times which will yield optimum fiber densities on the filter for almost all airborne fiber concentrations from 1 to 10 fibers/cm³. These optimum times have been calculated and are presented in Figure 4. Note

that the optimum times given by Figure 4 are approximate and can be varied by as much as $\pm 25\%$. The nomogram is intended as a guide to be used where no prior knowledge of the air concentration is available.

8.1.4. End of Sampling Period

Remove the field monitor, replace the plastic top cover and the small end caps, and store the monitor. Always shut off the pump when changing monitors to avoid contaminating or damaging the pump. Record the pump shutoff time and flow rate in the logbook.

8.1.5. Blanks

With each batch (25 to 50 filters) of samples sent for analysis, submit two unopened field monitors which have been subjected to the same treatment as the samples except that they were not exposed to the sampling environment. Label these as blanks. If the blanks yield fiber counts greater than 5 fibers/ 100 fields, then the entire sampling procedure should be examined carefully for the cause of contamination. The mounting solution of Section 8.2.1 should also be examined for contamination and/or crystal growth.

8.1.6. Shipping

The field monitors in which the samples are collected should be shipped in a rigid container with sufficient packing material to prevent crushing.

8.1.7. Numbers of Samples

When sampling for the Federal ceiling standard of 10 fibers ($>5 \mu\text{m}$)/ cm^3 , [29 CFR 1910-1001(b) (3), effective July 7, 1972], only one sample (15 minutes maximum duration) is necessary, theoretically. However, several samples should be taken during expected periods of peak air concentrations to allow for detection of gross sampling or counting errors.

When sampling for determination of noncompliance with the Federal 8-hour TWA standard of 2 fibers ($>5 \mu\text{m}$)/ cm^3 , [29 CFR 1910.1001(b) (2)], one should continuously sample as large a portion of the work day as is feasible for airborne concentrations of about 2 to 10 fibers/ cm^3 . However, for a lower airborne concentration such as 0.5 fiber/ cm^3 , one sample might require 4 to 8 hours sampling time in order to get the proper filter fiber density (Section 8.1.3). For this situation, the 8-hour TWA exposure would be determined from one 8-hour or two 4-hour samples as appropriate.

8.2. Sample Preparation

8.2.1. Preparation of Mounting Solution

A very important part of the sample evaluation is the mounting process. This process involves a special mounting medium of prescribed viscosity. The proper viscosity is important in order to expedite filter dissolving and still minimize particle migration. After the sample has been mounted, an elapsed time of approximately sixty minutes is needed before the sample is ready for evaluation.

Combine the dimethyl phthalate and diethyl oxalate in a one to one ratio by volume and pour into a Wheaton balsam bottle. Add approximately 0.05 (± 0.005) grams of new membrane filter per milliliter of solution to reach the necessary viscosity. The mixture must be stirred periodically until the filters have dissolved and a homogeneous mixture is formed. The normal shelf life of the mounting solution is about three months. Twenty milliliters of mounting solution will prepare approximately 300 samples.

8.2.2. Sample Mounting

Cleanliness is important! A dirty working area may result in sample contamination and erroneous counts. The following steps should be followed when mounting a sample.

1. Clean the slides and cover slips with lens tissue. Lay each slide down on a clean surface with the frosted end up. It is a good practice to rest one edge of the cover slip on the slide and the other edge on the working surface. By doing this, you keep the bottom surface (the one which contacts the filter) from becoming contaminated.
2. Wipe all the mounting tools clean with lens tissue and place them on a clean surface (such as lens tissue). All tools should be wiped clean prior to mounting each sample.

3. Using the glass rod supplied with the Wheaton balsam bottle, apply a drop of mounting solution onto the center of the slide. It may be necessary to adjust the quantity of solution so that after the cover slip has been placed on top, the solution extends only slightly beyond the filter boundary. If the quantity is greater than this, particle migration may occur.
4. Using another glass rod, spread the mounting media into a triangular shape. The size of this triangle should coincide with the dimension of the filter wedge.
5. Separate the middle and bottom sections of the field monitor case to expose the filter. Cut a triangular wedge from the center to the edge of the filter using the scalpel. The size of the wedge should approximate one-eighth of the filter surface. The filter can be very carefully removed from the cassette for cutting, but this should only be done with great care.
6. Grasp the filter wedge with the tweezers on the perimeter of the filter which was clamped between the monitor case sections. Do not touch the filter with your fingers. Place the wedge, **sample side up**, upon the mounting medium.
7. Pick up a clean cover slip with tweezers and carefully place it on the filter wedge. Once this contact has been made, **do not reposition the cover slip**.
8. Label the slide with the sample number and current date before proceeding to the next filter: On the bottom (backside) of the slide, trace the perimeter of the filter wedge with a felt tip marking pen. This will enable the counter, after the filter has become transparent, to stay within the filter perimeter when counting.
9. The sample should become transparent within fifteen minutes. If the filter appears cloudy, it may be necessary to press very lightly on the cover slip. This is rarely necessary; however, counting should not be started until an hour after the mounting. This allows the microscopic texture of the filter to become invisible to microscope viewing.
10. Discard the sample mount after two days if it has not been counted. Crystals appearing similar to asbestos fibers may begin to grow at the mounting media/air interfaces. They seldom present any problems if the slide is examined before two days. In any case, stay away from the filter's edges when counting and sizing.

8.3. Counting of Fibers

- 8.3.1. Place the slide on the mechanical stage of the microscope and position the center of the wedge under the objective lens and focus upon the sample. Start counting from one end of the wedge and progress along a radial line to the other end (count in either direction from perimeter to wedge tip). Random fields are selected, without looking into the eyepieces, by slightly advancing the slide in one direction with the mechanical stage control.
- 8.3.2. It is essential to continually scan over a range of focal planes (generally the upper 10 to 15 micrometers of the filter surface) with the fine focus control during each field count. This is especially necessary for asbestos fibers due to their impaction into the filter matrix.
- 8.3.3. On most airborne samples, asbestos fibers will generally have fiber diameters less than one micrometer. Therefore, it is necessary to look carefully for faint fiber images.
- 8.3.4. Regularly check phase ring alignment.
- 8.3.5. When an agglomerate (mass of material) covers a significant portion of the field of view (approx 1/6 or greater)--reject the field and select another. (Do not include it in the number of fields counted.) However, report the fact as it may have meaning on other data collection.
- 8.3.6. Bundles of fibers are counted as one fiber unless both ends of the fiber can be clearly resolved.
- 8.3.7. Count only fibers with a length to width ratio greater than or equal to 3:1.
- 8.3.8. Count only fibers greater than 5 micrometers in length. (Be as accurate as possible in accepting fibers near this length.) Measure curved fibers along the curve to estimate the total length.
- 8.3.9. Count as many fields as necessary to yield a total count of at least 100 fibers. Exceptions: a) count at least 20 fields even if you count more than 100 fibers, and b) stop at 100 fields even if you haven't reached 100 fibers.

8.3.10. For fibers that cross either one or two sides of the counting field, the following procedure is used to obtain a representative count.

COUNT any fiber greater than 5 micrometers in length that lies entirely within the counting area. COUNT as "1/2 fiber" any fiber with only one end lying within the counting area. DO NOT COUNT any fiber crossing any two sides.

Reject and do not count all other fibers. Refer to Figures 5 through 10. Note that the fibers in Figures 5 through 10 **are not representative** of the appearance of most asbestos fibers. Most fibers have a very faint image.

9. Calibration and Standards

9.1. Sampling Train Calibration

The accurate calibration of the sampling pump is essential to the correct calculation of the air volume sampled. The frequency of calibration is dependent on the use, care, and handling to which the pump is subjected. Pumps must be recalibrated if they have just been repaired, misused, or received from the manufacturer. If the pump receives hard usage, more frequent calibration may be necessary. Ordinarily, pumps should be calibrated in the laboratory both before they are used in the field and after they have been used to collect a large number of field samples.

The accuracy of calibration is dependent upon the type of instrument used as a reference. The choice of a calibration instrument will depend largely on where the calibration is performed. For laboratory testing, a 1-liter buret used as a soap bubble flow meter or wet-test meter is recommended. Other standard calibrating instruments, such as a spirometer, Marriott's bottle, or dry gas meter can be used. The calibration should be of sufficient precision that the 95% confidence limits on the flow rate are $\pm 10\%$ (95% of the flow rates will fall within $\pm 10\%$ of the calibrated value). Instructions for calibration with the soap bubble flow meter follow. The sampling train used (pump, hose, filter cassette) in the pump calibration should be the same as the one used in the field.

- 9.1.1. Check the voltage of the pump battery with a voltmeter both with the pump off and while it is operating to assure adequate voltage for calibration. If necessary, charge the battery to manufacturer's specifications.
- 9.1.2. Fill a beaker with 10 ml of soap solution.
- 9.1.3. Connect the filter cassette inlet to the top of the buret with a length of hose.
- 9.1.4. Turn the pump on and moisten the inside of the soap bubble meter by immersing the open end of the buret into the soap solution and drawing bubbles up the inside of the buret. Perform this task until the bubbles are able to travel the entire length of the buret without breaking.
- 9.1.5. Adjust the pump rotameter to provide a flow between 1.5 to 2.5 lpm.
- 9.1.6. With a water manometer, check that the pressure drop across the filter is less than 13 inches of water (about 1 inch of mercury).
- 9.1.7. Start a soap bubble up the buret and measure the time it takes for the bubble to travel a minimum volume of 1 liter.
- 9.1.8. Repeat the procedure in 9.1.7 at least three times, average the results, and calculate the calibrated flowrate by dividing the volume traveled by the soap bubble by the elapsed time. If the range between the highest and lowest of the three flow rates is greater than about 0.33 lpm, then the calibration should be repeated since it is likely that the precision is not adequate.
- 9.1.9. Data required for the calibration include the volume measured, elapsed time, pressure drop, air temperature, atmospheric pressure (or elevation), pump serial number, date, and name of person performing the calibration.
- 9.1.10. Corrections to the flow rate for pumps with rotameters may be necessary if the pressure (elevation) or temperature where the samples are collected (actual flow rate) differs significantly from that where the calibration was performed (indicated flow rate). Actual flow rates at time of sampling may be calculated for a linear scale rotameter by using the following correction formula:

$$Q_{actual} = Q_{indicated} \sqrt{\left(\frac{P_{cal}}{P_{actual}}\right) * \left(\frac{T_{actual}}{T_{cal}}\right)}$$

where both pressure (P) and temperature (T) are in absolute units such as:

psia = psig + 14.7

deg Rankin = deg Fahrenheit + 460

deg Kelvin = deg Celsius + 273

9.2. Microscope Setup

9.2.1. Porton Reticle and the Counting Field

The asbestos fiber count procedure consists of comparing fiber length to the diameters of calibrated circles of a Porton reticle, and counting all fibers greater than 5 micrometers in length lying within a given counting field area. The Porton reticle is a glass plate inscribed with a series of circles and rectangles. The left half of the reticle is divided into six rectangles constituting the counting field. The counting field is illustrated in Figures 5 through 10.

9.2.2. Placement in Eyepiece

The Porton reticle is placed inside the Huygenian eyepiece where it rests on the field limiting diaphragm. If other types of eyepieces are used, it may be necessary to insert a counting collar for retaining the reticle. The reticle should always be kept clean, since dirt on the reticle is in focus and could complicate the counting and sizing process.

9.2.3. Stage Micrometer

The Porton reticle cannot be used for counting until it has been properly calibrated with a stage micrometer. Most stage micrometer scales are approximately two millimeters long and are divided into units of one-hundredth of a millimeter (ten micrometers).

9.2.4. Microscope Adjustment

When adjusting the microscope, follow the manufacturer's instructions while observing the following guidelines.

1. The light source image must be in focus and centered on the condenser iris or annular diaphragm.
2. The particulate material to be examined must be in focus.
3. The illuminator field iris must be in focus, centered on the sample, and opened only to the point where the field of view is illuminated.
4. The phase rings (annular diaphragm and phase-shifting elements) must be concentric.

9.2.5. Porton Reticle Calibration Procedure

Each eyepiece-objective-reticle combination on the microscope must be calibrated. Should any of the three be changed (disassembly, replacement, zoom adjustment, etc.), the combination must be recalibrated. Calibration may change if interpupillary distance is changed. For proper calibration, the following procedure should be followed closely. With a 10X objective in place, place the stage micrometer on the mechanical stage, focus the millimeter scale, and center the image. Change to the 40-45X objective and adjust the first millimeter scale division to coincide with the left boundary of the Porton rectangle. Measure the distance between the left and extreme right boundaries of the Porton rectangle, estimating any portion of the final division. This measurement represents 200 L units. The rectangle is 100 L units on the short vertical dimension. The calculated "L" is inserted into the formula $D = L(2^N)^{1/2}$ where "N" is the circle number (indicated on the reticle) and "D" is the circle diameter. Since the circle diameters vary logarithmically, every other circle doubles in diameter. For example, circle number three is twice the diameter of number one; number four is twice the diameter of number two. When the circle sizes have been determined, the counting field area which consists of the left six smaller rectangles can be calculated from the relation $10,000 L^2$. This completes the reticle calibration for this specific objective-eyepiece-reticle combination.

Example for Porton Reticle

The following calibration was obtained for a pair of 10X Huygenian eyepieces and a 43X objective:

200 L = 0.148 mm = 148 micrometers

100 L = 0.074 mm = 74 micrometers

One L-unit = 0.74 micrometers

Thus Circle #1 has a diameter $D = L(2^N)^{1/2} = 0.74(2^1)^{1/2} = 0.74(1.414) = 1.05$ micrometers.

Then our circle diameter calibration table looks like:

Diameter of Circle #1 = 1.05 micrometers

#2 = 1.48

#3 = 2.09

#4 = 2.96

#5 = 4.19

#6 = 5.92

Field area = (10,000) (L²) = (100 L) (100 L) = (0.074) (0.074) = 0.0055 mm²

Thus fibers with a length greater than a distance halfway between the diameters of the #5 and #6 circles would be counted.

If a Patterson Globe and Circle reticle is used, a different calculation procedure is required. The circle diameters are related as follows. The #25 circle diameter is (0.1) (reticle length).

The circle diameters are proportional to the ratio of their numbers. Thus the #20 circle diameter is (20/25) or 0.8 times the #25 circle diameter.

10. Calculations

10.1. The average airborne asbestos fiber concentration estimated by the filter sample may be calculated from the following formula:

$$AC = \frac{\left(\left(\frac{FB}{FL} \right) - \left(\frac{BFB}{BFL} \right) \right) (ECA)}{(1000)(FR)(T)(MFA)}$$

where:

AC = Airborne fiber concentration in (fibers >5 μm)/cm³.

BFB = Total number of fibers counted in the BFL fields of the blank or control filters in fibers >5 μm.

BFL = Total number of fields counted on the blank or control filters.

ECA = Effective collecting area of filter (855 mm² for a 37-mm filter with effective diameter of 33 mm).

FR = Pump flow rate in liters/min (lpm).

FB = Total number of fibers counted in the FL fields in fibers >5 μm.

FL = Total number of fields counted on the filter.

MFA = Microscope count field area in mm² (generally 0.003 to 0.006).

T = Sample collection time in minutes.

10.2. Recount criteria. It is very desirable for a counter to conduct a "blind recount" for about 1 in every 10 filter wedges (slides) counted. Alternatively, a second counter could perform the blind recount. In training sessions for novice counters, the trainee should conduct a blind recount for filter wedges counted by an experienced, proficient counter. In all cases, we will observe differences between the first and second counts of the same filter wedge. Most of these differences will be due to chance alone, that is, due to the random variability (precision) of the count method. Statistical recount criteria enable us to decide whether observed differences can reasonably be explained due to chance alone or are probably due to systematic differences between counters or microscopes or due to some other biasing factor.

The following recount criterion is for a pair of counts that estimate some airborne fiber concentration (AC) in fibers/cm³. The criterion is given at the type-1 error level. That is, there is a 5% maximum risk that we will reject a pair of counts for the reason that one might be biased, when the large observed difference is really due to chance.

Reject a pair of counts because one might be biased if:

$$(AC_2 - AC_1) \text{ exceeds } 2.77(\overline{AC})(CV_{FB})$$

where:

AC_1 = lower estimated airborne fiber concentration

AC_2 = higher estimated airborne fiber concentration

\overline{AC} = average of the two airborne concentration estimates

CV_{FB} = average CV for the two concentration estimates which are a function of the total fiber count (FB) in each case. Use the relation in Section 4 or Figure 3.

For a pair of counts on the same filter, reject the pair because one might be biased if:

$$(FB_2 - FB_1) \text{ exceeds } 2.77(\overline{FB})(CV_{FB}^-)$$

where:

FB_1 = lower fiber count on the filter (total fibers)

FB_2 = higher fiber count on the filter (total fibers)

\overline{FB} = average of the two total fiber counts

CV_{FB}^- = CV_T for the value FB. Use the relation in Section 4 or Figure 3.

11. References

- 11.1. Lynch, J. R., K. J. Kronoveter, and N. A. Leidel, "Validity of the Poisson Distribution in Dust Counting", unpublished.
- 11.2. Weidner, R. B. and H. E. Ayer, "Dust Exposure in Asbestos Processing", Transactions of the American Conference of Governmental Industrial Hygienists, May 1972, pp. 103-121, San Francisco, California.
- 11.3. Conway, R. E. and W. D. Holland, "Statistical Evaluation of the Procedure for Counting Asbestos Fibers on Membrane Filters", LFE Corporation, Richmond, California. Prepared for the Asbestos on Membrane Assoc/North America, New York, 1973.
- 11.4. Leidel, N. A. and K. A. Busch, "An Evaluation of Phase Contrast Microscopes for Asbestos Counting", presented at the 1974 American Industrial Hygiene Conference, Miami Beach, Florida, May 18, 1974, unpublished.
- 11.5. Beckett, S.T. and M.D. Attfield, "Inter-Laboratory Comparison of the Counting of Asbestos Fibers Sampled on Membrane Filters", Ann Occup Hyg 17:85-96, 1974.
- 11.6. Rajhans, G. S. and G. M. Bragg, "A Statistical Analysis of Asbestos Fiber Counting in the Laboratory and Industrial Environment", Am Ind Hyg Assoc J 36(12):909-915, 1975.
- 11.7. Leidel, N. A. and K. A. Busch, "Statistical Methods for the Determination of Noncompliance with Occupational Health Standards", NIOSH Technical Publication 75-159, 1975.
- 11.8. Leidel, N. A., K. A. Busch, and J. R. Lynch, "Occupational Exposure Sampling Strategy Manual", NIOSH Technical Publication 77-173, 1977.
- 11.9. Leidel, N. A.; K. A. Busch, and W. E. Crouse, "Exposure Measurement Action Level and Occupational Environmental Variability", NIOSH Technical Publication 76-131, 1975.
- 11.10. Comments of the Johns-Manville Corporation with Respect to the Notice of Proposed Rulemaking: Occupational Exposure to Asbestos, Federal Register, October 9, 1975. Submitted to the public record at the U. S. Department of Labor, Occupational Safety and Health Administration, April 1976.
- 11.11. Leidel, N. A., S. G. Bayer, R. D. Zumwalde, and K. A. Busch, USPHS/NIOSH Membrane Filter Method for Evaluating Airborne Asbestos Fibers, to be published by NIOSH in 1977.
- 11.12. Needham, G. H., The Practical Use of the Microscope, Charles C. Thomas Publishing Corporation, Springfield, Illinois, 1958.
- 11.13. Clark, G. L., The Encyclopedia of Microscopy, Rheinhold Publishing Corporation, New York, 1961.
- 11.14. McCrone, W. C. and J. G. Delly, I. The Particle Atlas, Edition Two, Ann Arbor Science Publishers, Inc., Ann Arbor, Michigan, 1973.

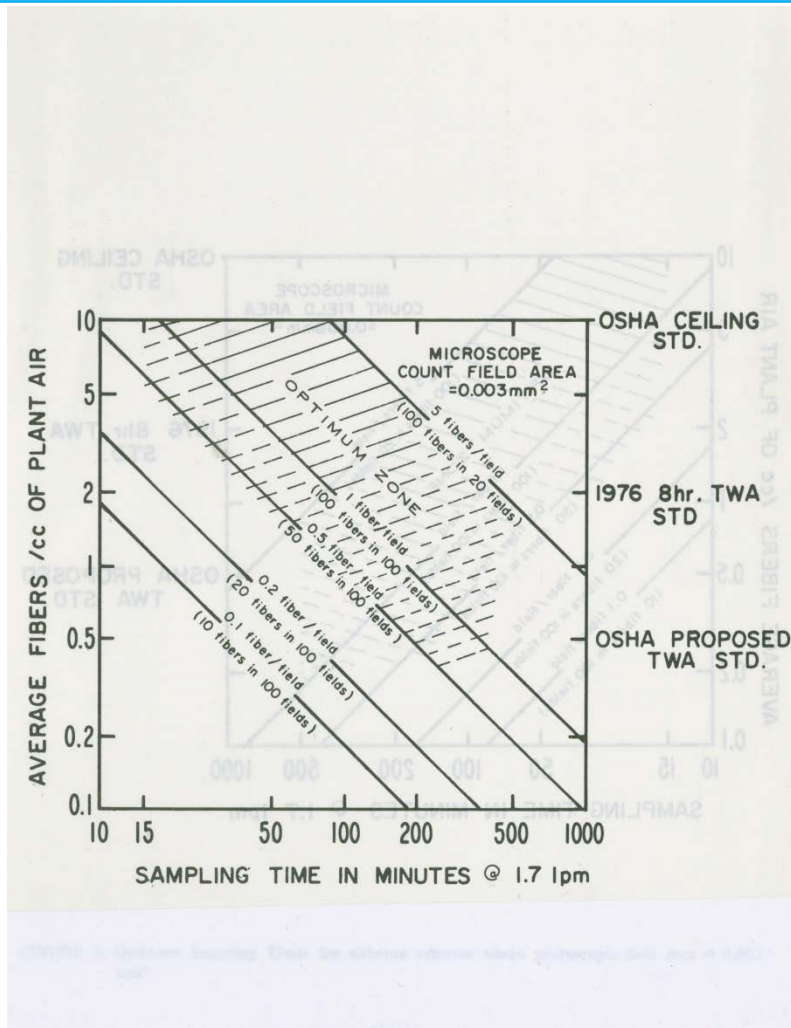

Figure 1 Optimum Sampling Times for airborne asbestos where microscopic field area = 0.003 mm²

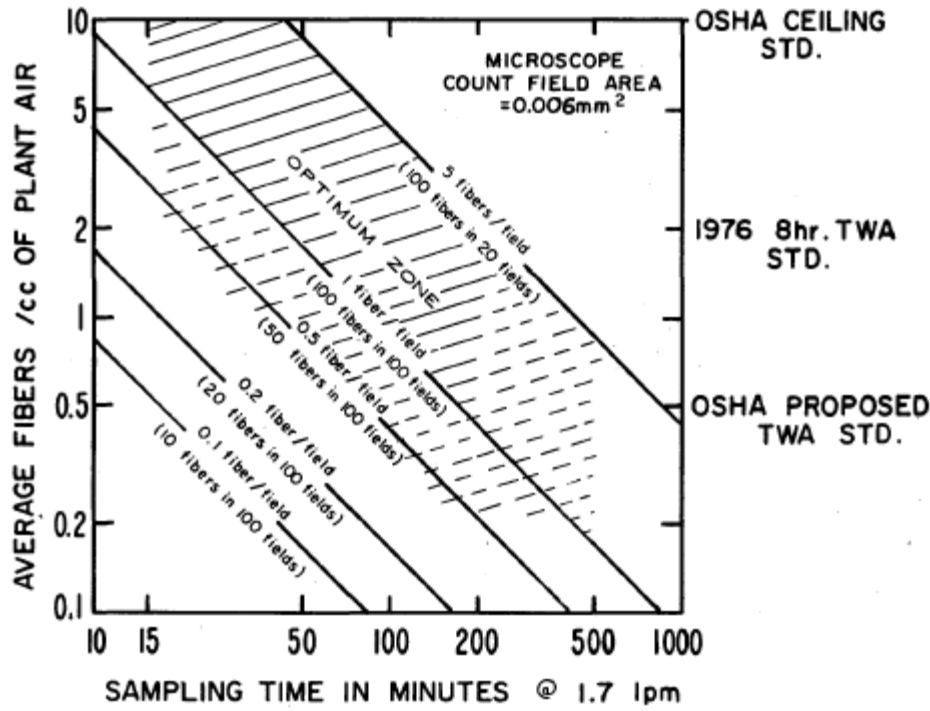

Figure 2 Optimum sampling times for airborne asbestos where microscopic field area = 0.006 mm²

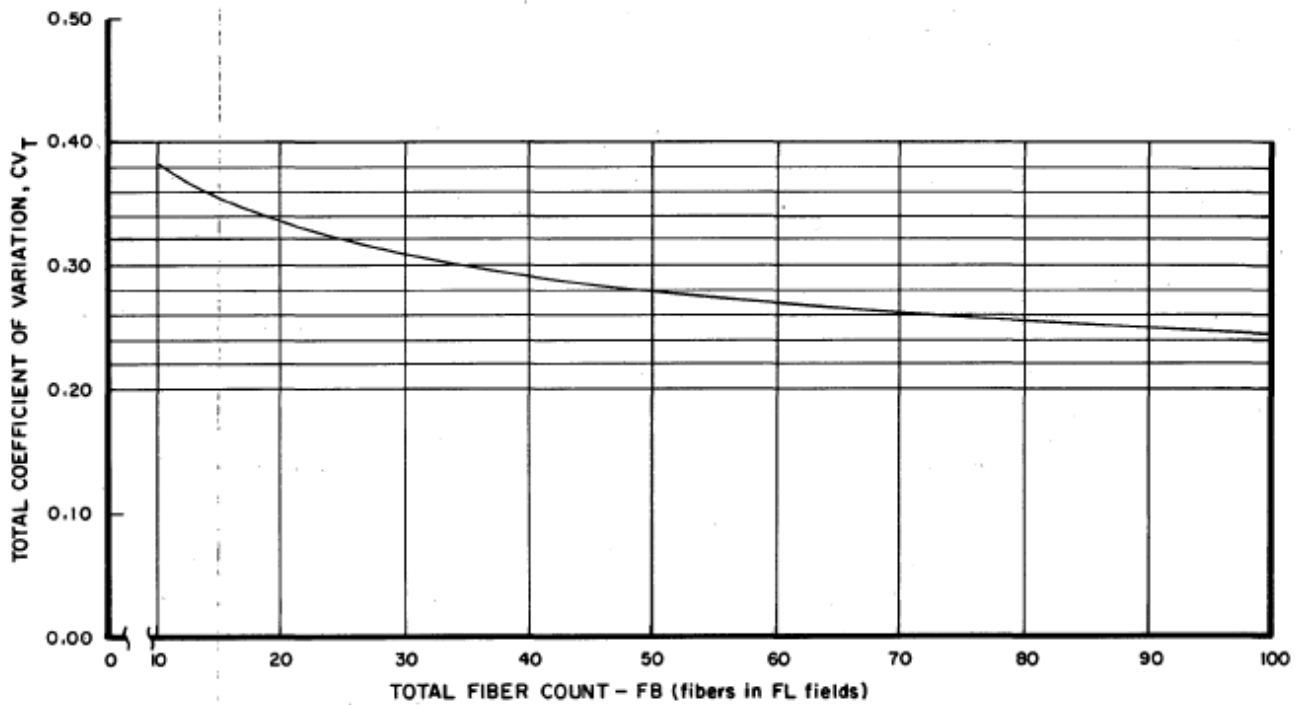

Figure 3 Total coefficient of variation as a function of total fiber count

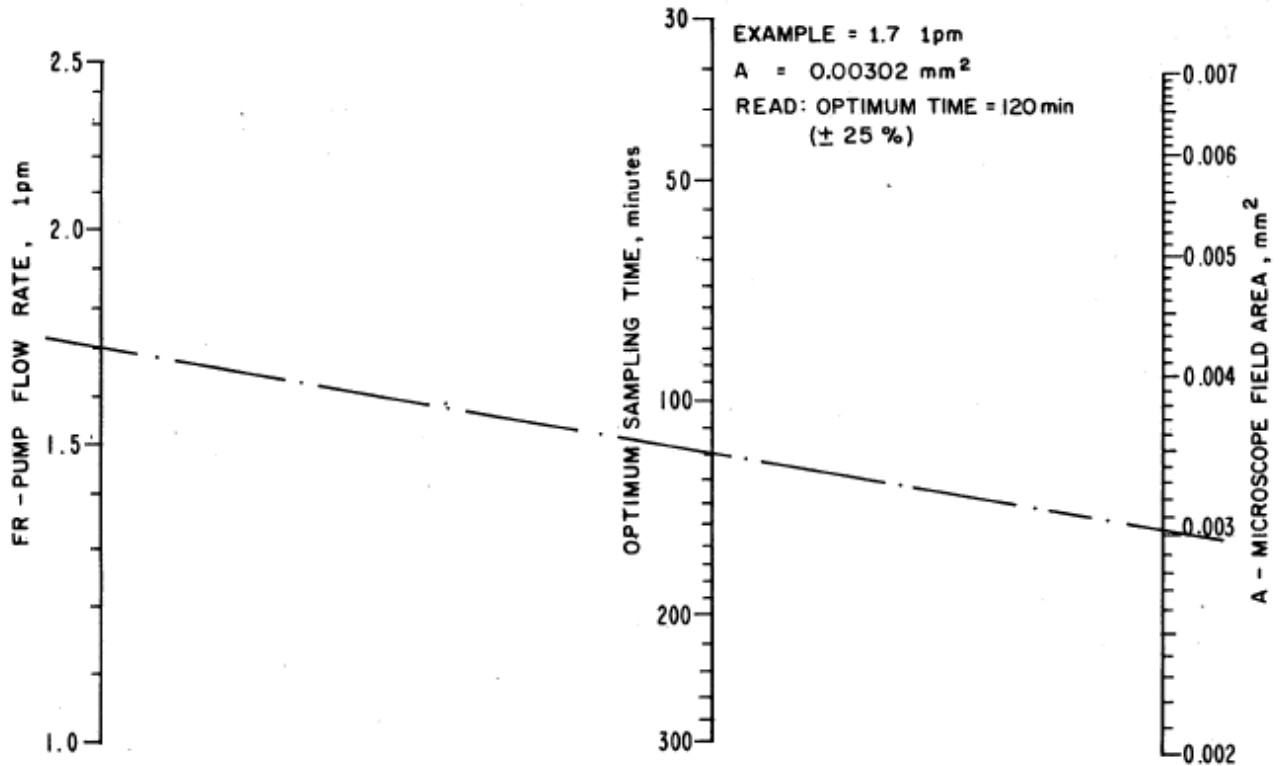

Figure 4 Nomogram of optimum sampling times for airborne asbestos fibers in concentrations of 1 to 10 fibers/cm³

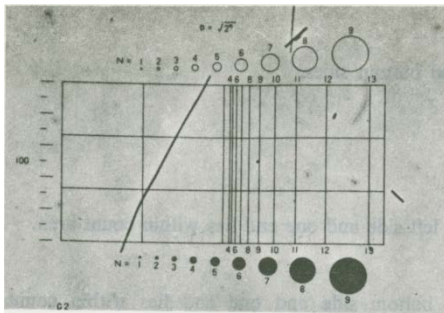

Figure 5 DO NOT COUNT. Fiber crosses top and bottom sides.

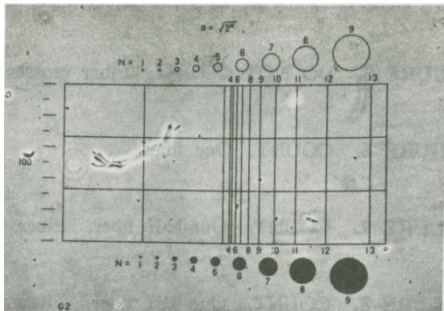

Figure 6 COUNT. One fiber.

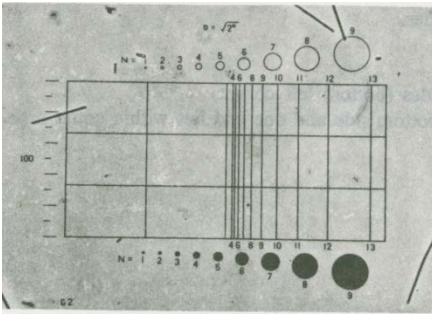

Figure 7 COUNT. One-half fiber. Fiber crosses left side and one end lies within the count area.

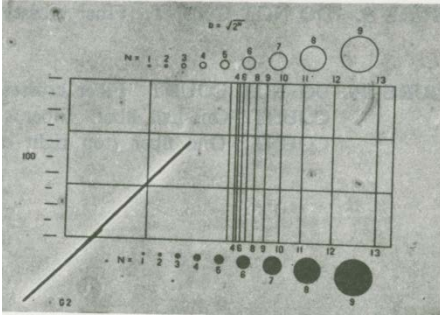

Figure 8 COUNT. One-half fiber. Fiber crosses bottom side and one end lies within count area.

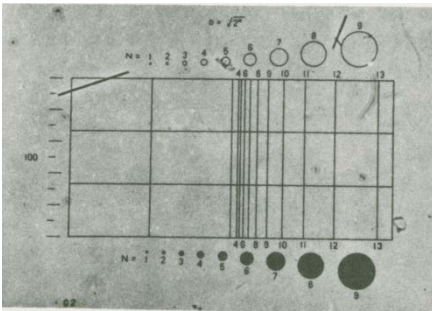

Figure 9 DO NOT COUNT. Fiber crosses two sides.

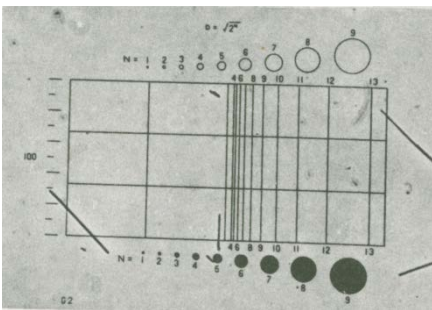

Figure 10 DO NOT COUNT. Fiber crosses two sides (bottom left corner). COUNT. One-half fiber. Fiber crosses bottom side and one end lies within count area. COUNT. One fiber (top right corner).



ALKALI METAL CATIONS Na⁺, K⁺, Li⁺

7405

NaOH, KOH, LiOH

MW: 40.00 (NaOH);
56.11 (KOH);
23.95 (LiOH)

CAS: 1310-73-2 (NaOH)
1310-58-3 (KOH);
1310-65-2 (LiOH)

RTECS: WB4900000 (NaOH)
TT2100000 (KOH);
OJ6307070 (LiOH)

METHOD: 7405, Issue 1

EVALUATION: FULL

Issue 1: 20 March 2018

OSHA: 2 mg/m³ (NaOH)

NIOSH: C 2 mg/m³ (NaOH, KOH); IDLH 10 mg/m³ (NaOH)

OTHER OELs: Refs. [1,2]

PROPERTIES: basic, hygroscopic, caustic solids and aerosols, VP not significant

SYNONYMS: sodium hydroxide; potassium hydroxide; lithium hydroxide; alkali (LiOH, NaOH, KOH); caustic soda (NaOH); caustic potash (KOH); lye (NaOH, KOH)

| SAMPLING | | MEASUREMENT | |
|--|--|--|---|
| SAMPLER: | FILTER, 37-mm quartz fiber, in 2- or 3-piece filter holder | TECHNIQUE: | Ion Chromatography |
| FLOW RATE: | 2-4 L/min | ANALYTE: | Na ⁺ , K ⁺ , Li ⁺ |
| VOL-MIN: | 30 L | DISSOLUTION: | 10 mL 0.005 M H ₂ SO ₄ , 15 minutes in ultrasonic bath |
| -MAX: | 1000 L | ELUENT: | 0.005 M H ₂ SO ₄ |
| SHIPMENT: | routine | DETECTOR: | Conductivity detector |
| SAMPLE STABILITY: | ≥7 days at 25 °C & ≥27 days at 4 °C [3]. | CALIBRATION: | ≈0.5 to ≈10 mg/L Na ⁺ , K ⁺ , Li ⁺ in 0.005 M H ₂ SO ₄ |
| BLANKS: | 3 field blanks minimum per sample set | RANGE: | <0.01 to >5 mg Na ⁺ , K ⁺ per sample; <0.05 to >2.5 mg Li ⁺ per sample [3,4] |
| ACCURACY | | ESTIMATED LOD: | 0.003 mg Na ⁺ , K ⁺ per sample; 0.002 mg Li ⁺ per sample [3] |
| RANGE STUDIED: | NaOH: 0.08 to 3.7 mg/m ³ KOH: 0.07 to 7.4 mg/m ³ ; LiOH: 0.16 to 7.2 mg/m ³ [3] | PRECISION (\bar{S}_r): | NaOH: 0.009 to 0.030; KOH: 0.008 to 0.019; LiOH: 0.007 to 0.010 [3,4] |
| BIAS: | negligible | | |
| OVERALL PRECISION ($\hat{S}_{r,T}$): | NaOH: 0.023 to 0.066; KOH: 0.018 to 0.043; LiOH: 0.016 to 0.023 [3] | | |
| EXPANDED UNCERTAINTY*: | <22% for all three cations [6] | | |

*Accuracy calculations were carried out in accordance with ISO guidelines [5] rather than NIOSH accuracy criteria.

APPLICABILITY: The method is meant for the measurement of alkaline dusts. It is specific for Na⁺, K⁺, and Li⁺ but does not differentiate between the hydroxides and their corresponding salts if both are present in the air. If the cations are present only in the form of hydroxides, the method is specific for these basic compounds. In other circumstances, the results obtained represent the highest air concentration of the hydroxides that could be extant. The method can also be used to measure alkaline earth hydroxides such as calcium hydroxide [3,4].

INTERFERENCES: Sodium and potassium are ubiquitous in the environment and, if present in the sampled air at high concentrations, other soluble salts of Na and K can positively interfere. High concentrations of ammonium can interfere with the sodium peak in the chromatographic signal.

OTHER METHODS: NIOSH Method 7401 for alkaline dusts is an acid-base titrimetric procedure that measures hydroxide concentration (alkalinity), $[\text{OH}^-]$ [7]. A harmonized international standard, ISO 17091 [4], has been published.

REAGENTS:

1. Sodium, potassium and lithium standard solutions, 1000 ± 10 mg/L; traceable to national standards.
2. Calibration stock solution: sodium and potassium, 50 mg/L; lithium, 25 mg/L. Pipet 625 μL Li standard solution and 1250 μL of each of the Na and K standard solutions into 25-mL volumetric flask. Dilute to volume with deionized water. This solution can be stored at 4°C for at least 2 months.
3. Sulfuric acid stock solution, 2.5 M H_2SO_4 .
4. Sulfuric acid extraction / eluent solution, 0.005 M H_2SO_4 . Pipet 2 mL 2.5 M sulfuric acid into a 1-L volumetric flask containing deionized water. Fill to volume using deionized water.
5. Water, deionized, ≥ 18.2 $\text{M}\Omega\text{-cm}^{-1}$ resistivity.

*See SPECIAL PRECAUTIONS.

EQUIPMENT:

1. Samplers: 37-mm diameter quartz fiber filters in cassette filter holders.
NOTE: Sodium and potassium are ubiquitous in the environment and their presence in filter materials can lead to high blanks. Thus it is essential to check blank levels of each batch of filters.
2. Personal sampling pump, 2 to 4 L/min, with flexible connecting tubing.
3. Flow meter, portable.
4. Ion chromatograph (IC) with autosampler, cation exchange column (e.g., 250 mm x 4 mm) with guard column (e.g., 50 mm x 4 mm), column oven capable of maintaining column temperature at 40°C, column thermostat, suppressor (e.g., cation self-regenerating suppressor) and conductivity detector.
5. Data analysis unit (e.g., computer).
6. Volumetric flasks, polypropylene, 25-mL, 50-mL, 1-L.
NOTE: For this method, it is preferable to use plastic labware rather than glassware.
7. Adjustable pipettors with plastic tips, 10-10000 μL .
8. Screw-cap polyethylene vessels, 15-20 mL.
9. Autosampler vials, polypropylene, with screw-caps and silicon-polytetrafluoroethylene (PTFE) septa.
10. Disposable syringes, 5-10 mL.
11. Disposable filters, 0.45 μm pore size PTFE, 25-mm diameter, suitable for IC.
12. Ultrasonic bath.
13. Ultrapure water system.
14. Tweezers, plastic or plastic-tipped.

SPECIAL PRECAUTIONS: Wear appropriate personal protection during sampling activities and analysis. It is essential that suitable gloves, eye protection, laboratory coat, etc., be used when working with the chemicals. Perform sample preparation and analysis in a clean, well-ventilated area that is well removed from any possible contamination. Any area of skin affected by the stock, dissolution or detection solutions must be immediately washed with plenty of water. Avoid exposure by contact with skin or eyes, or by inhalation of vapor.

SAMPLING, SAMPLE TRANSPORT AND STORAGE:

1. Calibrate each personal sampling pump with a representative sampler in line.

2. Sample at an accurately known flow rate between 2 and 4 L/min for a sample size of 30 to 1000 L. Do not overload the samplers.
3. When sampling is completed, remove the samplers and cap them.
4. Submit at least three blank filters as field blanks from the same lot as sample filters for each set of samples, and handle them in the same way as field samples.
5. Transport the samples to the laboratory in a manner that prevents contamination or damage to the filters, and in accordance with established chain-of-custody procedures [8].
6. The samples can be stored at room temperature for one week; for longer storage, refrigerate the samples at 4 °C.
NOTE: These storage times relate to the evaluated conditions. Longer storage at room temperature may be possible, but was not tested.
7. Samples should be analyzed no more than four weeks after sample collection.

SAMPLE PREPARATION:

8. Remove sample cassettes from storage and, if necessary, bring to room temperature.
9. Using tweezers, remove the sample filters from the filter holder (cassette) and place them in 15-20 mL plastic (polyethylene) screw-cap vessels.
10. Rinse the inside walls of the cassette with 2-3 mL of extraction / eluent solution (0.005 M H₂SO₄) and direct the rinsate(s) into the plastic vessels that contain the filters.
11. Bring the final volume of extraction / eluent solution inside the vessels to 10 mL, ensuring that the filters are completely immersed.
12. Seal the 15-20 mL plastic vessels and place them in an ultrasonic bath. Sonicate for 15 minutes and then allow to stand for at least 30 minutes.
13. For each prepared sample, using a disposable syringe, remove 5 mL of the extraction solution and filter into an autosampler vial through a disposable PTFE filter.

CALIBRATION AND QUALITY CONTROL:

14. Prepare at least five calibration working solution standards to cover the required concentration range, e.g., from 0.6 to 20 mg/L for Na⁺ and K⁺ and 0.3 to 10 mg/L for Li⁺. Accurately pipet appropriate volumes of calibration stock solution into individual, labeled volumetric flasks. Dilute to the mark with water, close, and mix.
NOTE: These calibration working solutions can be stored at room temperature for at least 2 weeks. Before use, their stability should be confirmed. If stability is inadequate, these solutions should be prepared fresh daily.
15. Calibrate the ion chromatograph with the above five calibration solutions by preparing a calibration graph of peak height (in e.g., μ S) vs. concentration (mg/L) for each cation.
16. Analyze calibration working standards together with samples, reagent blanks and field blanks at a frequency of at least 1 per 20 samples (3 minimum of each).
17. Check recoveries with at least two media blanks and 3 quality control spikes per 20 samples.

MEASUREMENT:

18. Set the ion chromatograph to the recommended eluent flow rate (e.g., 1.0 mL/min) and system pressure (ca. 10 MPa) and other conditions specified by the instrument manufacturer.
19. Using the autosampler, a 25- μ L sample aliquot of the contents of each autosampler vial is injected into the ion chromatograph.
20. Measure the peak heights of the lithium, sodium and potassium peaks (at retention times of approximately 4, 4.5 and 6 min, respectively) (Figure 1). If the peak height exceeds the linear calibration range, dilute with eluent, reanalyze, and apply the appropriate dilution factor in calculations.

CALCULATIONS:

21. Calculate the mass concentration of each cation, C (mg/m³), in the air volume sampled, V (m³):

$$C = \frac{(C_i \times V_i \times F) - (C_0 \times V_0)}{V},$$

where:

C_0 = mean concentration, in mg/L, of cation in field blank test solution;

C_i = concentration, in mg/L, of the i^{th} cation ($i = \text{Na}^+, \text{K}^+, \text{Li}^+$) in sample test solution;

V = volume of air sample (m³), where 1 L = 0.001 m³

V_0 = volume of field blank test solution (L)

V_i = volume of sample test solution (L) for i^{th} cation ($i = \text{Na}^+, \text{K}^+, \text{Li}^+$)

F = dilution factor for each sample test solution

EVALUATION OF METHOD:

The method was evaluated in accordance with an applicable international consensus standard, ISO 20581 [9]. The component of variation of the method arising from analytical variability, as determined from spiked and dried quartz fiber filters, was found to be in the range of 0.9% to 3.0% for NaOH, 0.8% to 1.9% for KOH, and 0.7% to 1.0% for LiOH [3,6]. Mean recoveries from these samples were $102 \pm 2\%$ for NaOH, $100 \pm 2\%$ for KOH and $101 \pm 2\%$ for LiOH [3]. The expanded uncertainty of the method, using a coverage factor (k) of 2 [10], was estimated as <22% for all three hydroxides [6]. Method quantitation limits were calculated based on the use of low-spike calibration standards [3, 11]. For a sampled air volume of 420 L, the quantitation limits were 0.041 mg/m³ for NaOH and LiOH and 0.034 mg/m³ for KOH. Storage stability of four weeks was demonstrated by recoveries >95% for quartz fiber filters spiked with NaOH, KOH and LiOH and stored at room temperature for 7 days and 4 °C thereafter [6]. Influence of humidity was investigated at a relative humidity (RH) of 70%, established by means of a dynamic test gas apparatus [3]. Amounts of 0.1 – 0.2 mg of NaOH, KOH and LiOH were spiked onto quartz fiber filters and then dried. Over two hours, air with RH=70% was drawn through these filters at 3.5 L/min; humidity was not found to influence the analytical recoveries of the three hydroxides.

REFERENCES:

- [1] American Conference of Governmental Industrial Hygienists (ACGIH) [2016]. Threshold Limit Values for chemical substances and physical agents & Biological Exposure Indices. Cincinnati, OH: ACGIH; updated annually.
- [2] Institut für Arbeitsschutz der Deutschen Gesetzlichen Unfallversicherung (IFA) [no date]. GESTIS international limit values, <http://limitvalue.ifa.dguv.de/>. Date accessed January 17, 2018.
- [3] Breuer D, Heinrich B [2001]. Alkali metal hydroxides and alkaline earth hydroxides, Method no. 1 (lithium hydroxide, sodium hydroxide, potassium hydroxide, calcium hydroxide); in Air monitoring methods, Vol. 8 – The MAK Collection for Occupational Health and Safety. Weinheim, Germany: Wiley-VCH.
- [4] International Organization for Standardization (ISO) [2013]. ISO 17091, Workplace air – Determination of lithium hydroxide, sodium hydroxide, potassium hydroxide and calcium dihydroxide – Method by measurement of corresponding cations by suppressed ion chromatography. Geneva: ISO.
- [5] ISO [1995]. ISO Guide 98, Guide to the expression of uncertainty in measurement. Geneva: ISO.

- [6] Breuer D [2009]. Hydroxides (LiOH, NaOH, KOH, Ca(OH)₂), in BGIA working folder, Sheet no. 7683. Berlin: Erich-Schmidt Verlag.
- [7] NIOSH [1994]. Method 7401, Alkaline dusts. In Schlect PC, O'Connor PF, eds. NIOSH manual of analytical methods, 4th ed. Cincinnati, OH: U.S. Department of Health and Human Services, Centers for Disease Control and Prevention, National Institute for Occupational Safety and Health, DHHS (NIOSH) Publication No. 94-113.
- [8] ASTM International [2010]. ASTM D4840, Standard guide for sampling chain of custody procedures. West Conshohocken, PA: ASTM International.
- [9] ISO [2016]. ISO 20581, Workplace air quality – General requirements for the performance of procedures for the measurement of chemical agents. Geneva: ISO.
- [10] Comité Européen de Normalisation (CEN) [2009]. EN 13890, Workplace exposure – Procedures for measuring metals and metalloids in airborne particles – Requirements and test methods. Brussels: CEN.
- [11] NIOSH [1995]. Guidelines for air sampling and analytical method development and evaluation. By Kennedy ER, Fischbach TJ, Song R, Eller PM, Shulman SA. Cincinnati: U.S. Department of Health and Human Services, Centers for Disease Control and Prevention, National Institute for Occupational Safety and Health, DHHS (NIOSH) Publication No. 95-117.

METHOD CONTRIBUTORS:

Dietmar Breuer, Dr. rer. nat., Petra Heckmann and Krista Gusbeth, IFA, Sankt Augustin, Germany; final editing by Kevin Ashley, Ph.D., NIOSH.

Disclaimer: Mention of any company or product does not constitute endorsement by the National Institute for Occupational Safety and Health (NIOSH), Centers for Disease Control and Prevention (CDC). In addition, citations to websites external to NIOSH do not constitute NIOSH endorsement of the sponsoring organizations or their programs or products. Furthermore, NIOSH is not responsible for the content of these websites. All web addresses referenced in this document were accessible as of the publication date.

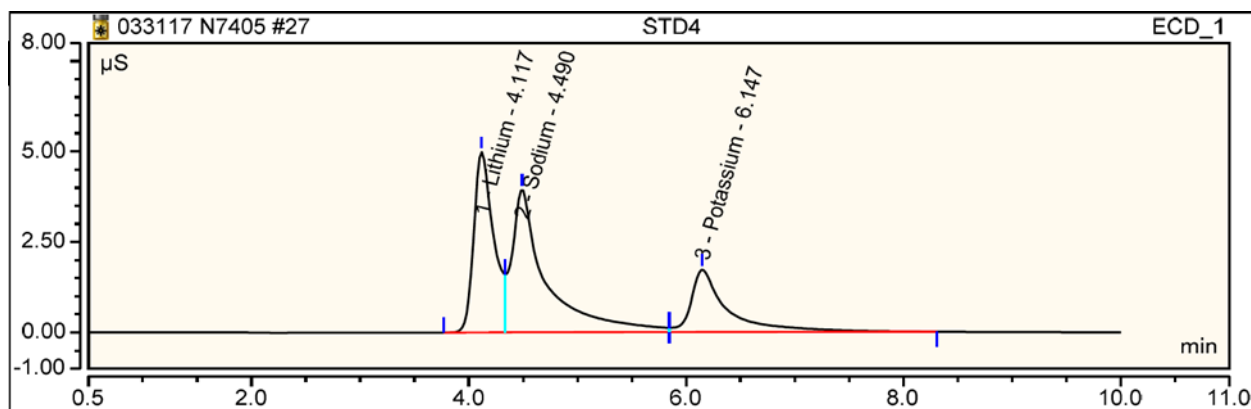
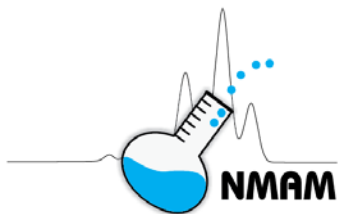

FIGURE 1. Chromatogram of standard solution containing Li, Na, and K.



ZINC OXIDE

7502

ZnO MW: 81.38 CAS: 1314-13-2 RTECS: ZH4810000

METHOD: 7502, Issue 3

EVALUATION: FULL

Issue 1: 15 February 1984
Issue 3: 20 October 2015

OSHA: 5 mg/m³ (fume, resp dust); 15 mg/m³ (total dust)
NIOSH: 5 mg/m³, C 15 mg/m³ (15 min) (dust); 5 mg/m³, STEL
10 mg/m³ (fume)

PROPERTIES: Solid; d 5.61 g/cm³ @ 25 °C; MP 1975 °C

SYNONYMS: China white; zinc white; zincite

| SAMPLING | MEASUREMENT |
|--|---|
| <p>SAMPLER: FILTER (0.8 µm PVC membrane, 25 mm diameter, in open-face cassette)</p> <p>FLOW RATE: 1 L/min to 3 L/min</p> <p>VOL-MIN: 10 L -MAX: 400 L</p> <p>SHIPMENT: Routine</p> <p>SAMPLE STABILITY: Stable</p> <p>BLANKS: 2 to 10 field blanks per set</p> <p>BULK SAMPLE: High-volume air sample required</p> | <p>TECHNIQUE: X-RAY POWDER DIFFRACTION</p> <p>ANALYTE: Crystalline zinc oxide; direct analysis on filter</p> <p>XRD: Copper target X-ray tube; optimize for intensity; 1° slit; graphite monochromator; scintillation detector; slow step scan, 0.02 degrees per 10 seconds; integrated intensity with background subtraction</p> <p>CALIBRATION: Suspensions of zinc oxide in 2-propanol</p> <p>RANGE: 50 µg to 2000 µg per sample</p> <p>ESTIMATED LOD: 5 µg per sample</p> <p>PRECISION (\bar{S}_r): 0.15 @ 1 mg/m³; 0.05 for greater than 2 mg/m³</p> |
| ACCURACY | |
| <p>RANGE STUDIED: 0.1 mg/m³ to 11 mg/m³ [1,2] (180 L samples)</p> <p>BIAS: 2.7% [2,3,4]</p> <p>OVERALL PRECISION (\hat{S}_{rt}): 0.09 [2]</p> <p>ACCURACY: ±21.6%</p> | |

APPLICABILITY: The working range is 0.25 mg/m³ to 10 mg/m³ for a 200 L air sample. The method does not distinguish zinc oxide fume from zinc oxide dust.

INTERFERENCES: Major interferences include ferric oxide, zinc, diamminedichlorozinc, triammonium pentachlorozincate(3-), diammonium tetrachlorozincate(2-), and diammonium zinc disulfate hexahydrate; these are resolved by using alternate analyte peaks. Particle size affects intensity measurements.

OTHER METHODS: This method combines and replaces NIOSH methods P&CAM 222 [1] and S316 [5]. The criteria document contains an elemental analysis for zinc [6].

REAGENTS:

1. Zinc oxide, ACS reagent grade. Average particle size between 0.5 μm and 10 μm .
2. 2-Propanol.*
3. Desiccant.
4. Glue or tape for securing filters to XRD holders.

*See SPECIAL PRECAUTIONS.

EQUIPMENT:

1. Sampler: polyvinyl chloride (PVC) or PVC-acrylonitrile membrane filters, 25 mm diameter, 0.8 μm pore size; three-piece filter cassette.
NOTE: An extension cowl on the filter cassette is desirable to produce a more uniform deposit and to prevent contamination of the open-face filter during sampling.
2. Personal sampling pump, 1 L/min to 3 L/min, with flexible connecting tubing.
3. High-volume sampling pump, 10 L/min.
4. X-ray powder diffractometer equipped with copper target X-ray tube and scintillation detector.
5. Reference specimen (mica, Arkansas stone or other stable standard) for data normalization.
6. Filtration apparatus and side arm vacuum flask with 25 mm filter holders.
7. Analytical balance (0.01 mg), magnetic stirrer, ultrasonic bath or probe, volumetric pipettes and flasks, desiccator, reagent bottles with ground glass stoppers, drying oven, polyethylene wash bottle.

SPECIAL PRECAUTIONS: 2-Propanol is flammable.

SAMPLING:

1. Calibrate each personal sampling pump with a representative sampler in line.
2. Sample open-face at 1 L/min to 3 L/min for a total sample size of 10 L to 400 L. Do not exceed 2 mg total dust loading on the filter.
3. Take a high-volume (4000 L) air sample using a clean sampler and high-volume sampling pump in the same area as the personal sample(s) for qualitative identification.

SAMPLE PREPARATION:

4. Mount field samples and blanks on XRD sample holders using appropriate methods for securing the sample to the XRD holder.

CALIBRATION AND QUALITY CONTROL:

5. Prepare two suspensions of zinc oxide in 2-propanol by weighing 10 mg and 50 mg of the dry powder to the nearest 0.01 mg. Quantitatively transfer to a 1 L glass-stoppered bottle using 1 L 2-propanol.
6. Suspend the powder in 2-propanol by using an ultrasonic probe or bath for 20 min. Immediately move the flask to a magnetic stirrer with thermally-insulated top and add a stirring bar to the suspension. Cool the solution to room temperature before withdrawing aliquots.
7. Prepare a series of standard filters using the 10 mg/L and 50 mg/L suspensions. Using appropriate pipets, prepare a sufficient number of standards in triplicate to cover the analytical range (or sample range if known). Standards at 20 μg , 30 μg , 50 μg , 100 μg , 200 μg , and 500 μg are usually sufficient.

8. Mount a filter on the filtration apparatus. Place several mL 2-propanol on the filter surface. Turn off the stirrer and shake vigorously by hand. Within a few seconds of setting the bottle down, remove the lid and withdraw an aliquot from the center of the suspension. Do not adjust the volume in the pipet by expelling part of the suspension. If more than the desired aliquot is withdrawn, return all of the suspension to the bottle, rinse and dry the pipet. Transfer the aliquot from the pipet to the filter funnel, keeping the tip of the pipet near the surface of the liquid but not submerged.
9. Rinse the pipet with several mL of 2-propanol, draining the rinse into the funnel. Repeat the rinse several more times.
10. Apply vacuum and rapidly filter the suspension. Leave vacuum on until filter is dry. Do not wash down the sides of the funnel after the deposit is in place to avoid disturbing it. Transfer the filter to the XRD sample mount.
11. Perform step scans on the standards using the same diffraction peaks and instrumental conditions as for samples (step 16). The resulting intensities for standards, I_x^o , are normalized in the following procedure.
12. Determine the net count, I_r , of the reference specimen before or after each unknown, standard, or blank is scanned. Use a diffraction peak of high intensity that can be measured rapidly but reproducibly (less than 1% S_r). Select a convenient normalization scale factor, N , which is approximately equivalent to the net count for the reference specimen peak. This factor never changes and should be used for all measurements made on a particular diffractometer. Calculate and record the normalized intensity, \hat{I}_x^o , for the analyte or silver peaks on each sample, field blank, media blank, and standard:

$$\hat{I}_x^o = \frac{I_x^o}{I_r} N.$$

NOTE: Normalizing to the reference specimen intensity compensates for long-term drift in X-ray tube intensity. If intensity measurements are stable, the reference specimen may be run less frequently. In this case, the net intensities of the analyte, I_x , should be normalized to the most recently measured reference intensity.

13. Prepare a calibration graph (\hat{I}_x^o vs. W μg of analyte).
NOTE: Poor reproducibility at any given level indicates problems in the sample preparation technique and new standards should be made. The data should lie along a straight line. A weighted least squares ($1/\sigma^2$ weighting) is preferable. Curvature can be eliminated with absorption corrections based on the mass absorption coefficient of the analyte [7,8,9].
14. Determine the initial slope, m , of the linear portion of the calibration graph in counts per microgram. The intercept, b , of the line with the \hat{I}_x^o axis should be approximately zero.
NOTE: A large negative intercept indicates an error in determining the background. This may arise from incorrectly measuring the baseline or from interference by another phase at the angle of background measurement. A large positive intercept indicates an error in determining the baseline or that an impurity is included in the measured peak.

MEASUREMENT:

15. Obtain a qualitative X-ray diffraction scan (broad 2-theta range) of the high-volume respirable sample to determine the presence of zinc oxide and any matrix interference. The expected diffraction peaks are as follows:

| Zinc Oxide Peak (2-Theta Degrees) | | |
|-----------------------------------|-----------|----------|
| Primary | Secondary | Tertiary |
| 36.26 | 31.75 | 34.44 |

16. Analyze the sample filters by step-scanning the most intense interference-free diffraction peak of zinc oxide and determine the integrated intensity. Measure the background on each side of the peak

for one half the time used for peak scanning and add the counts from each side for a total (average) background. Determine the 2-theta position of the background for each sample. The net count or intensity, I_x , is the difference between the peak integrated count and the total background count. The net intensity is normalized as in step 12 to obtain \hat{I}_x .

17. Scan each field blank over the same 2-theta range used for the analyte. These analyses serve only to verify that contamination of the filters has not occurred. The analyte peak should be absent.

CALCULATIONS:

18. The concentration, C , of zinc oxide in the air sample is:

$$C = \frac{(\hat{I}_x - b)}{mV}, \mu\text{g/L or mg/m}^3,$$

where: \hat{I}_x = normalized intensity for sample peak,
 b = intercept of calibration graph (\hat{I}_x vs. W),
 m = initial slope of calibration graph (counts per microgram), and
 V = air volume sampled (L).

In heavily-loaded samples, particularly those rich in heavy elements, X-ray absorption may cause reduced intensities and underestimation of zinc oxide. If this is suspected, an absorption correction can be made [8]. The collection filters and blanks are mounted on a smooth metal plate (substrate) for XRD quantitation. The substrate should have a non-interfering diffraction peak which is measured at the same time as the zinc oxide peak. By measuring the substrate peak on both samples and blanks, an absorption correction like that in the silica method (NIOSH method 7500) can be made. The absorption correction factor must be calculated for each sample from the formula in NIOSH method 7500, which takes into account the diffraction angles for the particular substrate chosen. Atree-Williams used a silver filter under the collection filter [7].

EVALUATION OF METHOD:

In a comparison of this method with atomic absorption spectrophotometry [3,4], zinc was determined on 15 Gelman DM-800 filters containing added zinc oxide in the range 250 μg to 1000 μg . The average percent difference for the 15 pairs was 2.7%. NIOSH method S316 was validated with generated samples in the range of 2.4 mg/m^3 to 9.9 mg/m^3 [2,5,10]. A pooled \hat{S}_{τ} of 0.088 was found for 18 samples of 180 L collected from the aerosol.

REFERENCES:

- [1] NIOSH [1977]. Zinc oxide in air: P&CAM 222. In: Taylor DG, ed. NIOSH manual of analytical methods. 2nd ed. Vol. 1. Cincinnati, OH: U.S. Department of Health, Education, and Welfare, Center for Disease Control, National Institute for Occupational Safety and Health, DHEW (NIOSH) Publication No. 77-157-A, available as accession No. PB274845 from NTIS [www.ntis.gov].
- [2] NIOSH [1977]. Backup data report: zinc oxide fume, No. S316. In: Ten NIOSH analytical methods, set 3. Cincinnati, OH: U.S. Department of Health, Education, and Welfare, Center for Disease Control, National Institute for Occupational Safety and Health, available as accession No. PB275834 from NTIS [www.ntis.gov]. Unpublished.
- [3] Haartz JC, Bolyard ML, Abell MT [1975]. Quantitation of zinc chloride and zinc oxide in airborne samples. Unpublished paper presented at the American Industrial Hygiene Conference, Minneapolis, MN, June 1–6.
- [4] Dollberg DD, Abell MT, Lange BA [1980]. Occupational health analytical chemistry: quantitation using x-ray powder diffraction. In: Dollberg DD, Verstuyft AW, eds. Analytical techniques in

- occupational health chemistry. Washington, DC: American Chemical Society, ACS Symposium Series No. 120, pp. 43–65.
- [5] NIOSH [1978]. Zinc oxide fume: Method S316. In: Taylor DG, ed. NIOSH manual of analytical methods. 2nd ed. Vol. 4. Cincinnati, OH: U.S. Department of Health, Education, and Welfare, Center for Disease Control, National Institute for Occupational Safety and Health, DHEW (NIOSH) Publication No. 78-175, available as accession No. PB83-105437 from NTIS [www.ntis.gov].
- [6] NIOSH [1975]. Criteria for a recommended standard: occupational exposure to zinc oxide. Cincinnati, OH: U.S. Department of Health, Education, and Welfare, Center for Disease Control, National Institute for Occupational Safety and Health, DHEW (NIOSH) Publication No. 76-104 [www.cdc.gov/niosh/docs/1970/76-104.html].
- [7] Atree-Williams S, Lee J, Mezin NV [1977]. Quantitative x-ray diffractometry on respirable dust collected on Nuclepore filters. *Ann Occup Hyg* 20(2):109–126.
- [8] Leroux J, Powers CA [1970]. Direct x-ray diffraction quantitative analysis of quartz in industrial dust films deposited on silver membrane filters. *Occup Health Rev* 21(1):26–34.
- [9] Williams PP [1959]. Direct quantitative diffractometric analysis. *Anal Chem* 31(11):1842–1844.
- [10] NIOSH [1980]. Development and validation of methods for sampling and analysis of workplace toxic substances. By Gunderson EC, Anderson CC, Smith RH, Doemeny LJ. Cincinnati, OH: U.S. Department of Health and Human Services, Centers for Disease Control, National Institute for Occupational Safety and Health, DHHS (NIOSH) Publication No. 80-133, available as accession No. PB89-182042 from NTIS [www.ntis.gov].

METHOD WRITTEN BY:

D. D. Dollberg, Ph.D, and M. T. Abell, NIOSH/DPSE.

DISCLAIMER: Mention of any company or product does not constitute endorsement by NIOSH. In addition, citations to websites external to NIOSH do not constitute NIOSH endorsement of the sponsoring organizations or their programs or products. Furthermore, NIOSH is not responsible for the content of these websites. All web addresses referenced in this document were accessible as of the publication date.

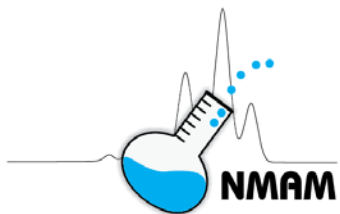

CHROMIUM, HEXAVALENT

7600

Cr(VI) AW: 52.00 CAS: 18540-29-9 RTECS: GB6262000
 CrO₃ MW: 99.99 CAS: 1333-82-0 RTECS: GB6650000

METHOD: 7600, Issue 3

EVALUATION: FULL

Issue 1: 15 May 1989

Issue 3: 20 October 2015

OSHA: 0.005 mg/m³ (1910.1026); C 0.1 mg/m³ as CrO₃
 (exceptions to 1910.1026)
 NIOSH: 0.0002 mg/m³ (8 h); carcinogen

PROPERTIES: Oxidizing agent

SYNONYMS: Vary depending upon the compound

| SAMPLING | MEASUREMENT |
|--|---|
| <p>SAMPLER: FILTER (5.0 µm PVC membrane)</p> <p>FLOW RATE: 1 L/min to 4 L/min</p> <p>VOL-MIN: 34 L @ 0.005 mg/m³ -MAX: 400 L</p> <p>SHIPMENT: Routine</p> <p>SAMPLE STABILITY: Analyze within 2 weeks [1]</p> <p>FIELD BLANKS: 2 to 10 field blanks per set</p> | <p>TECHNIQUE: VISIBLE ABSORPTION SPECTROPHOTOMETRY</p> <p>ANALYTE: Chromium-diphenylcarbazone complex</p> <p>EXTRACTION SOLUTION: 0.25 mol/L sulfuric acid or solution of 20 g/L sodium hydroxide and 30 g/L sodium carbonate (see steps 4 and 5)</p> <p>WAVELENGTH: 540 nm; 5 cm path length</p> <p>CALIBRATION: Standard solutions of potassium chromate in 0.25 mol/L sulfuric acid</p> |
| ACCURACY | <p>RANGE: 0.2 µg to 7 µg per sample</p> <p>ESTIMATED LOD: 0.05 µg per sample</p> <p>PRECISION (\bar{S}): 0.029 @ 0.3 µg to 1.2 µg per sample [3]</p> |
| <p>RANGE STUDIED: 0.05 mg/m³ to 0.2 mg/m³ [2] (22 L samples)</p> <p>BIAS: -5.48%</p> <p>OVERALL PRECISION (\hat{S}_{π}): 0.084 [2]</p> <p>ACCURACY: ±18.6%</p> | |

APPLICABILITY: The working range is 0.00042 mg/m³ to 3.6 mg/m³ for a 400 L air sample. This method may be used for the determination of soluble hexavalent chromium (using the acidic extraction solution) or insoluble hexavalent chromium (using the basic extraction solution) [3].

INTERFERENCES: Possible interferences are iron, copper, nickel, and vanadium; 10 µg of any of these causes an absorbance equivalent to about 0.02 µg hexavalent chromium due to formation of colored complexes. Interference due to reducing agents (e.g., elemental iron, divalent iron) is minimized by alkaline extraction (step 5).

OTHER METHODS: This method combines and replaces NIOSH methods P&CAM 169 [1], S317 [2], and P&CAM 319 [3]; the hexavalent chromium criteria document [4] contains a summary of more recent methods for air analysis, wipe analysis, and biological monitoring.

REAGENTS:

1. Sulfuric acid,* concentrated (98% mass fraction), reagent grade.
2. Sulfuric acid, 3 mol/L. Add 167 mL concentrated sulfuric acid to water in a 1 L flask; dilute to the mark.
3. Acidic extraction solution, sulfuric acid, 0.25 mol/L. Add 14.0 mL concentrated sulfuric acid to water in a 1 L flask; dilute to the mark.
4. Sodium carbonate, anhydrous, reagent grade.
5. Sodium hydroxide,* reagent grade.
6. Potassium chromate,* reagent grade.
7. Diphenylcarbazide solution. Dissolve 500 mg sym-diphenylcarbazide in 100 mL acetone and 100 mL water.
8. Hexavalent chromium standard,* 1000 µg/mL. Dissolve 3.735 g potassium chromate in deionized water to make 1 L, or use commercially available solution.
9. Calibration stock solution,* 10 µg/mL. Dilute 1000 µg/mL hexavalent chromium standard 1:100 with deionized water.
10. Basic extraction solution. Dissolve 20 g sodium hydroxide and 30 g sodium carbonate in deionized water to make 1 L of solution.
11. Glassware cleaning solution.* Add a volume of concentrated nitric acid to an equal volume of deionized water.
12. Nitrogen, purified.

*See SPECIAL PRECAUTIONS.

EQUIPMENT:

1. Sampler: Polyvinyl chloride (PVC) filter, 5.0 µm pore size, 37 mm diameter in polystyrene cassette filter holder.
NOTE: Some PVC filters promote reduction of hexavalent chromium. Check each lot of filters for recovery of hexavalent chromium standard.
2. Personal sampling pump, 1 L/min to 4 L/min, with flexible connecting tubing.
3. Vials, scintillation, 20 mL glass, PTFE-lined screw cap.[†]
4. Forceps, plastic.
5. Spectrophotometer, UV-visible (540 nm), with cuvettes, 5 cm path length.
6. Filtration apparatus, vacuum.[†]
7. Beakers, borosilicate, 50 mL.[†]
8. Watch glass.[†]
9. Volumetric flasks, 25 mL, 100 mL, and 1000 mL.[†]
10. Hotplate, 120 °C to 400 °C.
11. Micropipettes, 10 µL to 1 mL.
12. Centrifuge tubes, 40 mL, graduated, with plastic stoppers.[†]
13. Büchner funnel.[†]
14. Pipettes, TD, 5 mL.[†]

[†]Clean all glassware with the glassware cleaning solution and rinse thoroughly before use.

SPECIAL PRECAUTIONS: NIOSH considers all hexavalent chromium compounds to be suspect occupational carcinogens [4]. Concentrated acids are highly corrosive, and sodium hydroxide is caustic. All work with these compounds should be performed in a hood. Use proper protective clothing including gloves, safety glasses, and laboratory coat. Potassium chromate is a strong oxidizer with risk of fire and explosion upon contact with combustible substances and reducing agents.

SAMPLING:

1. Calibrate the sampling pump with a representative sampler in line.
2. Sample at an accurately known flow rate in the range 1 L/min to 4 L/min for a sample size of 34 L to 400 L. Do not exceed 1 mg total dust loading on the filter.
3. Remove the filter from the cassette within 1 h of completion of sampling and place it in a vial to be shipped to the laboratory. Handle the filter only with forceps. Discard the backup pad.

SAMPLE PREPARATION:

NOTE: There are two sample preparation techniques outlined below. For soluble chromates or chromic acid, follow step 4; for insoluble chromate or hexavalent chromium in the presence of iron, divalent iron, or other reducing agents, follow step 5.

4. Sample preparation for soluble chromates and chromic acid.
 - a. Remove the blank and sample filters from the vials, then fold and place them into centrifuge tubes.
 - b. Add 6 mL to 7 mL of acidic extraction solution to each tube, cap, and shake to wash all surfaces of the filter. Allow filter to remain in tube 5 min to 10 min [5].
 - c. Remove the filter from the tube with plastic forceps, carefully washing all surfaces with an additional 1 mL to 2 mL of acidic extraction solution. Discard the filters. Start reagent blanks at this point.
 - d. Filter the solution through a moistened PVC filter in a Büchner funnel to remove interferences from suspended dust. Collect the filtrate in a clean centrifuge tube. Rinse the bottle, which contained the filter, with 2 mL to 3 mL of acidic extraction solution and pour into the funnel. Rinse the funnel and filter with 5 mL to 8 mL of acidic extraction solution.
 - e. Add 0.5 mL diphenylcarbazide solution to each centrifuge tube. Bring the total volume in each centrifuge tube to 25 mL with acidic extraction solution. Shake to mix and allow color to develop (at least 2 min but no longer than 40 min [5]). Transfer the solution to a clean 5 cm cuvette and analyze within 40 min of mixing (steps 9, 10, and 11).

5. Sample preparation for insoluble chromates and for hexavalent chromium in the presence of iron or other reducing agents:

NOTE: If significant amounts of trivalent chromium are expected to be present, degas the sample solution by bubbling nitrogen through it for 5 min before proceeding and purge the headspace above the solution during step 5.a.

- a. Remove the PVC filter from the bottle, place it in a 50 mL beaker, and add 5.0 mL of basic extraction solution. Start reagent blanks at this point. Purge the headspace above the solution with nitrogen throughout the extraction process to avoid oxidation of any trivalent chromium. Cover the beaker with a watch glass and heat it to near the boiling point on a hotplate with occasional swirling for 30 min to 45 min. Do not boil the solution or heat longer than 45 min. Do not allow the solution to evaporate to dryness because hexavalent chromium may be lost owing to reaction with the PVC filter. An indication that hexavalent chromium has been lost in this manner is a brown-colored PVC filter.
- b. Cool the solution and transfer it quantitatively with distilled water rinses to a 25 mL volumetric flask, keeping the total volume about 20 mL.

NOTE: If the solution is cloudy, filter it through a PVC filter in a vacuum filtration apparatus using distilled water rinses.
- c. Add 1.90 mL of 3 mol/L sulfuric acid to the volumetric flask and swirl to mix.

CAUTION: Carbon dioxide will be evolved causing increased pressure in the flask. Let the solution stand for several minutes until vigorous gas evolution ceases.
- d. Add 0.5 mL diphenylcarbazide solution, dilute to the mark with distilled water and invert several times to mix thoroughly. Pour out about one-half of the contents of the flask, stopper the flask and shake it vigorously several times, removing the stopper each time to relieve pressure.

NOTE: This step releases bubbles of carbon dioxide which otherwise would cause high and erratic readings.
- e. Transfer an aliquot of the solution remaining in the flask to a 5 cm cuvette and analyze (steps 9, 10, and 11).

CALIBRATION AND QUALITY CONTROL:

6. Calibrate daily with at least six working standards. Transfer 6 mL to 7 mL of acidic extraction solution to each of a series of 25 mL volumetric flasks. Pipet 0 mL to 0.7 mL of 10 µg/mL calibration stock solution into the volumetric flasks. Add 0.5 mL diphenylcarbazide solution to each flask and sufficient acidic extraction solution to bring the volume to 25 mL. These working standards contain 0 µg to 7 µg hexavalent chromium.
7. Analyze the working standards together with blanks and samples (steps 9, 10, and 11).

8. Prepare a calibration graph [absorbance vs. μg hexavalent chromium].

MEASUREMENT:

9. Set wavelength on the spectrophotometer to 540 nm.
10. Set to zero using an acidic extraction solution reagent blank.
11. Transfer sample solution to a cuvette and record the absorbance.
 - NOTE 1: A sample containing 1.5 μg hexavalent chromium in 25 mL gives about 0.2 absorbance.
 - NOTE 2: If the absorbance values for the samples are higher than the standards, dilute using acidic extraction solution, repeat this step, and multiply the resulting absorbance by the appropriate dilution factor.

CALCULATIONS:

12. From the calibration graph, determine the mass of hexavalent chromium in each sample, W (μg), and in the average blank, B (μg).
13. Calculate the concentration, C (mg/m^3), of hexavalent chromium in the air volume sampled, V (L).

$$C = \frac{(W - B)}{V}, \mu\text{g}/\text{L} \text{ or } \text{mg}/\text{m}^3.$$

NOTE: If the hexavalent chromium concentration is to be reported as chromic acid (CrO_3), multiply C by 1.92 (MW of chromic acid divided by AW of chromium).

EVALUATION OF METHOD:

P&CAM 169 and S317 are essentially the same method and are suitable for soluble chromate and chromic acid. Method S317 was validated with generated samples of chromic acid mist [2,5], and P&CAM 169 was tested with field samples [1,6]. P&CAM 319 was developed because a method was needed to analyze for insoluble chromates [3]. This method was tested with insoluble chromates in matrices such as paints, primer, and ceramic powders [3].

Precision, analytical range, recovery data, etc., for the three methods pooled are as follows:

| | |
|----------------------------------|---|
| Total \hat{S}_r : | 0.084 |
| Measurement \bar{S}_r [1,2,3]: | 0.02 to 0.04 |
| Range [3]: | 0.5 $\mu\text{g}/\text{m}^3$ to 10 $\mu\text{g}/\text{m}^3$ |
| Collection efficiency [5]: | 94.5% |
| Sampling rate [1,3]: | 1.5 L/min to 2.5 L/min |
| Stability (two weeks) [1]: | 96% recovery |

REFERENCES:

- [1] NIOSH [1977]. Chromic acid mist in air: P&CAM 169. In: Taylor DG, ed. NIOSH manual of analytical methods. 2nd ed. Vol. 1. Cincinnati, OH: U.S. Department of Health, Education, and Welfare, Center for Disease Control, National Institute for Occupational Safety and Health, DHEW (NIOSH) Publication No. 77-157-A, available as accession No. PB274845 from NTIS [www.ntis.gov].
- [2] NIOSH [1977]. Chromic acid and chromates: Method S317. In: Taylor DG, ed. NIOSH manual of analytical methods. 2nd ed. Vol. 3. Cincinnati, OH: U.S. Department of Health, Education, and Welfare, Center for Disease Control, National Institute for Occupational Safety and Health, DHEW (NIOSH) Publication No. 77-157-C, available as accession No. PB276838 from NTIS [www.ntis.gov].
- [3] NIOSH [1980]. Hexavalent chromium: P&CAM 319. In: Taylor DG, ed. NIOSH manual of analytical methods. 2nd ed. Vol. 6. Cincinnati, OH: U.S. Department of Health and Human Services, Centers for Disease Control, National Institute for Occupational Safety and Health, DHHS (NIOSH) Publication No. 80-125, available as accession No. PB82-157728 from NTIS [www.ntis.gov].

- [4] NIOSH [2013]. Criteria for a recommended standard: occupational exposure to hexavalent chromium. Cincinnati, OH: U.S. Department of Health and Human Services, Centers for Disease Control and Prevention, National Institute for Occupational Safety and Health, DHHS (NIOSH) Publication No. 2013-128 [www.cdc.gov/niosh/docs/2013-128/].
- [5] NIOSH [1977]. Backup data report: chromic acid and chromates, No. S317. By Taylor DG, Kupel RE, Bryant JM. In: Documentation of the NIOSH validation tests. Cincinnati, OH: U.S. Department of Health, Education, and Welfare, Center for Disease Control, National Institute for Occupational Safety and Health, DHEW (NIOSH) Publication No. 77-185, available as accession No. PB274248 from NTIS [www.ntis.gov].
- [6] Abell MT, Carlberg JR [1974]. A simple reliable method for the determination of airborne hexavalent chromium. *Am Ind Hyg Assoc J* 35(4):229–233.

METHOD REVISED BY:

Martin T. Abell, NIOSH/DPSE; NIOSH method S317 validated under NIOSH Contract CDC-99-74-45.

DISCLAIMER: Mention of any company or product does not constitute endorsement by NIOSH. In addition, citations to websites external to NIOSH do not constitute NIOSH endorsement of the sponsoring organizations or their programs or products. Furthermore, NIOSH is not responsible for the content of these websites. All web addresses referenced in this document were accessible as of the publication date.



SILICA, Respirable Crystalline, by IR (KBr pellet)

7602

SiO₂

MW: 60.08

CAS: 14808-60-7
14464-46-1
15468-32-3

RTECS: VV7330000 (quartz)
VV7325000 (cristobalite)
VV335000 (tridymite)

METHOD: 7602, Issue 4

EVALUATION: FULL

Issue 1: 15 February 1984

Issue 4: 25 July 2017

OSHA: 0.05 mg/m³
NIOSH: 0.05 mg/m³; carcinogens
OTHER OELS: [1,2]

PROPERTIES: solid; d 2.65 g/cm³; crystalline transformation:
α-quartz to β-quartz @ 573 °C; quartz to tridymite @ 867 °C;
tridymite to cristobalite @ 1470 °C

SYNONYMS: free crystalline silica; silicon dioxide

| SAMPLING | | MEASUREMENT | |
|--|---|--|---|
| SAMPLER: | CYCLONE + PRE-WEIGHED FILTER (PVC), with conductive filter holder | TECHNIQUE: | INFRARED SPECTROMETRY |
| FLOW RATE: | ~2 to ~4 L/min, specific for the cyclone used | ANALYTE: | Quartz / Cristobalite |
| VOL-MIN: | 400 L | ASHING: | Muffle furnace or RF plasma asher |
| -MAX: | 1000 L (total dust < 4 mg) | PELLET: | Mix residue with KBr; press 13-mm pellet |
| SHIPMENT: | Routine | IR DETECTION: | Scan absorbance between 400 cm ⁻¹ and 1000 cm ⁻¹ |
| SAMPLE STABILITY: | Stable | CALIBRATION: | Certified reference material (CRM) respirable crystalline silica (RCS) quartz & cristobalite; e.g., NIST SRM 1878b quartz, NIST 1879a cristobalite, and/or other RCS CRMs; diluted in KBr and pressed into 13-mm pellet |
| BLANKS: | 3 field blanks minimum per sample set | RANGE: | 10 to >160 µg |
| ACCURACY | | ESTIMATED LOD: | 5 µg |
| RANGE STUDIED: | 5 to >160 µg | PRECISION (\bar{S}_r): | < 0.15 @ 30 µg per sample |
| BIAS: | Varies depending on matrix effects | | |
| OVERALL PRECISION ($\hat{S}_{r,T}$): | 0.18 [3] | | |
| ACCURACY: | ±19% at ≈40-160 µg per sample; ±36% at ≈15 µg per sample [4] | | |

APPLICABILITY: The working range is 0.025 to 0.4 mg/m³ for a 400-L air sample or 0.02 to 0.25 mg/m³ for a 1000-L air sample. Quartz and cristobalite have a major IR absorbance band at ≈800 cm⁻¹ and can be measured together if present in samples; tridymite can also be measured by IR, but its presence is rare in workplaces [5-9].

INTERFERENCES: Amorphous silica, kaolinite, muscovite, talc, albite, vermiculite and other minerals that absorb IR radiation in the 800 cm⁻¹ region are potential interferences to RCS measurement [5,10] [Table 1]. Potentially interfering silicates can be removed using a phosphoric acid cleanup procedure [11]. Calcite at >20% dust loading can negatively interfere by reacting with quartz during muffle ashing [11, 12]. The sample preparation procedures described in this method enable minimization of interferences.

OTHER METHODS: NIOSH Method 7603 describes IR measurement of respirable crystalline silica (RCS) after redeposition onto a filter for analysis (vs. use of a KBr pellet) [13]. X-ray diffraction (e.g., NIOSH Method 7500 [13]) is a complementary method for RCS measurement. An international voluntary consensus standard describing the measurement of RCS by IR spectrometry, ASTM D7439, has been promulgated [14].

REAGENTS:

1. Respirable crystalline silica (RCS) primary certified reference materials (CRMs); e.g., NIST SRM 1878b (quartz), NIST SRM 1879a (cristobalite) [15].
2. Potassium bromide (KBr), IR quality.
3. Kaolinite (kaolin) CRM.
4. Deionized water, ≥ 18 M Ω -cm resistivity.
5. 2-Propanol, reagent grade.
6. Ethanol, 95%, for cleaning of sample handling equipment.*
7. Hydrochloric acid (HCl), 9% w/w.* Add 25 mL conc. HCl (37% w/w) to 50 mL of deionized water, cool, and bring to 100 mL with deionized water.
8. Calibration stock standard, 0.5% w/w. Accurately weigh and thoroughly mix 5 g KBr (dried overnight at 110 °C) with 25 mg quartz. Store in a bottle in a desiccator.

*See SPECIAL PRECAUTIONS.

EQUIPMENT:

1. Sampler:
 - a. Filter, 37-mm dia., 5- μ m pore size, polyvinyl chloride (PVC), supported with backup pad or screen in 2-piece, conductive / static-dissipative filter holder.
 - b. Cyclone, respirable, designed to operate at a flow rate of ≈ 2 or ≈ 4 L/min, specific for each sampling device.
 - c. Sampling head holder, for keeping the cassette, cyclone and coupler tightly together so that air enters only through cyclone inlet.
2. Personal sampling pumps, for RCS sample collection at ≈ 2 or ≈ 4 L/min.
3. Infrared spectrometer, double-beam dispersive or Fourier transform device, with 4 cm^{-1} resolution or better.
4. Laboratory press (10 tons pressure), for preparing KBr pellets, with evacuable 13-mm KBr pellet die.
5. Vacuum pump, for connecting to laboratory press.
6. Low-temperature (RF plasma) asher and aluminum weighing pan, or muffle furnace and porcelain crucibles.
7. Analytical balance, capable of weighing to the nearest 0.001 mg.
8. Mortar and pestle, 50-mm agate or mullite
9. Metal microspatula
10. Non-serrate, non-magnetic forceps
11. Desiccator
12. Camel's hair brush
13. Glassine paper / weighing boats
14. Membrane filtration apparatus (47-mm)
15. Laboratory oven

SPECIAL PRECAUTIONS: Wear appropriate personal protection during sampling activities, sample preparation and analysis. It is essential that suitable gloves, eye protection, laboratory coat, etc., be used, especially when working with concentrated acids. Note that KBr is incompatible with strong acids. Ethanol and 2-propanol are flammable. Avoid exposure by inhalation of silica dust or acid fumes. Perform sample preparation and analysis in a clean, well-ventilated area that is well removed from any possible contamination. Any skin affected by exposure to acids must be immediately washed with plenty of water.

SAMPLING:

1. Calibrate each personal sampling pump with a representative sampler in line. Use a conductive filter holder.
2. Sample at ≈ 2 L/min [16] or ≈ 4 L/min [17] using a pump set at a specific flow rate for the selected cyclone, designed to collect the respirable aerosol fraction (in accordance with ISO 7708[18]), for a total sample size of 400 to 1000 L. Take care not to overload the filter.

NOTE 1: Do not allow the sampler assembly to be inverted at any time when using a cyclone. Turning the cyclone to anything more than a horizontal orientation may deposit oversized material from the cyclone body onto the filter.

NOTE 2: Higher sampling flow rates may be suitable for certain sampler designs [19].

3. After collection of samples, remove the filter holders from the cyclones. Seal the filter holders (cassettes) and transport them to the laboratory in a container designed to prevent damage in transit.

SAMPLE PREPARATION:

4. Use one of the following methods to prepare samples and blanks:
 - a. Low-temperature (RF plasma) asher: Remove the filters from filter holders and place them in clean, labelled aluminum dishes. Place the dishes in the low-temperature asher so that sample exposure to the plasma is optimized. Ash the samples according to manufacturer's instructions. Carefully bring the asher to atmospheric pressure and remove the dishes.
 - b. Muffle furnace: For samples expected to contain a significant amount of calcite (>20% of the total dust loading), wash filters with 9% w/w HCl per procedure in 4.b.i. For other samples, proceed to step 4.b.ii.
 - i. Place a 0.5- μ m pore size, 47-mm dia. PVC filter in the filtration apparatus. Remove the 37-mm dia. sample filter from the filter holder and center atop the 47-mm PVC filter. Clamp a funnel over the frit so that the dust deposit on the filter is completely exposed to rinsates. Add 10 mL of 9% HCl and 5 mL of 2-propanol; allow to stand for 5 min. Apply vacuum and slowly aspirate the acid and alcohol in the funnel. Wash with three successive 10-mL portions of deionized water. Release vacuum.
 - ii. Place 37-mm filter samples and blanks in porcelain crucibles, loosely cover, and ash in muffle furnace for 2 h at 600 °C (800 °C if graphite present). Allow to cool to room temperature.
5. Add approximately 300 mg KBr, weighed to the nearest 0.1 mg and dried overnight at 110 °C, directly to each sample. Mix the sample residue (remaining from the above ashing procedure) with KBr using a pestle and grind / homogenize the mixture with mortar and pestle. Quantitatively transfer the mixture to a 13-mm evacuable pellet die using glassine paper and camel's hair brush. Place the die into the laboratory press and apply requisite pressure to prepare the sample KBr pellet. Weigh the finished pellet to the nearest 0.1 mg and calculate the ratio of the weight of the finished pellet to the weight of KBr initially added. Clean sample handling equipment with ethanol between samples.

CALIBRATION AND QUALITY CONTROL:

6. Prepare at least 5 working standard KBr pellets. Calibration standards shall be prepared from primary RCS CRMs.

NOTE: Suitable RCS standards include primary reference materials such as NIST SRMs 1878b (quartz) and 1879a (cristobalite) [15]; the use of secondary reference materials as calibration standards is not appropriate for IR measurements [12, 20].

 - a. Weigh, to the nearest 0.001 mg, portions of primary CRMs containing 10 to 200 μ g RCS of material.
 - b. Add an accurately weighed (to the nearest 0.001 mg) 300 mg portion of KBr. Prepare KBr pellet samples as in Step 5. Compute the ratio of the weight of finished pellet / weight of solids added.
 - c. Measure the absorbance at 800 cm^{-1} for each KBr pellet calibration standard following the analytical procedure below (Step 9). Plot the absorbance vs. mass of SiO_2 (μ g).

7. If samples were low-temperature ashed (Step 4.a.) and kaolinite is known to be present in the matrix of the collected samples, prepare at least five different KBr pellets containing 100 to 600 μg of kaolinite. Measure the absorbance at 800 cm^{-1} (RCS) and at 915 cm^{-1} (kaolinite). Use the relationship between the RCS and kaolinite peak to correct the absorbance value at 800 cm^{-1} samples containing kaolinite [21].
8. Carry media blanks and filters spiked with known amounts of RCS (e.g., quartz) through the sample preparation procedures (Steps 4 and 5) to monitor for contamination and losses.
NOTE: Knowledge of and training in geochemistry and mineralogy is strongly recommended for users of this method. Although many analytical chemists are familiar with IR spectroscopy (e.g., as applied to organic analysis), mineralogical samples such as those containing RCS require additional knowledge of geochemistry and mineralogy to correctly interpret IR spectra and account for matrix interferences and mineral transformations.

MEASUREMENT:

9. Set the infrared spectrometer to absorbance mode and to the appropriate settings for quantitative analysis. For each IR scan, place a KBr pellet in the sample holder and obtain a spectrum at 4 cm^{-1} resolution or better from 400 cm^{-1} to 1000 cm^{-1} . Rotate the KBr pellet 45° and scan again. Repeat twice more until 4 scans have been obtained. Draw an appropriate baseline under the absorbance band at 800 cm^{-1} from approximately 820 to 670 cm^{-1} . Measure the absorbance from the 800 cm^{-1} peak maximum to baseline in absorbance units. Average the four absorbance values for each KBr pellet sample.
NOTE: If the peak at 800 cm^{-1} is small, expand the ordinate to enhance the peak height.
10. If the sample was ashed at low temperature (Step 4.a.), the presence of kaolinite will be indicated by an absorption band with maximum at 915 cm^{-1} . Draw an appropriate baseline under the absorbance band at 915 cm^{-1} from approximately 960 to 860 cm^{-1} . Measure the absorbance from the 915 cm^{-1} peak maximum to baseline.

CALCULATIONS:

11. To correct for the presence of kaolinite (if necessary), use the measured absorbance at 915 cm^{-1} (Step 10) and refer to the kaolinite curve (Step 6) to establish the corrected absorbance for RCS at 800 cm^{-1} . Use this corrected RCS absorbance value in Step 13.
12. If correction for kaolinite is not required, use the measured (uncorrected) absorbance at 800 cm^{-1} to determine the weight (W_s , μg) of RCS (e.g., quartz) from the calibration graph.
13. From the weight of RCS (W_s , μg), calculate its concentration, C (mg/m^3), in the volume of air sampled, V (L):

$$C = [W_s / V], \text{ mg}/\text{m}^3$$

14. If percent RCS (%Q) is of interest, divide the weight of RCS, W_s (μg), by the total sample weight, W_t (μg):

$$\%Q = [W_s / W_t] \times 100$$

EVALUATION OF METHOD:

From various experimental studies, analytical figures of merit for the KBr pellet IR method for RCS have been summarized in Ref. [14]. Filter collection was carried out using respirable cyclone samplers with flow rate $\approx 2\text{ L}/\text{min}$, with sampling volumes ranging from 300 to 1000 L. Following sample ashing with a plasma asher or muffle furnace, the remaining material was homogenized with KBr and pressed into a KBr pellet. IR spectrometric measurements were then carried out on the as-prepared KBr discs. By comparison of sample IR response to the signal from similarly-prepared CRM quartz standards, and with interference

correction [21], the RCS content was measured. Applicable analytical ranges were from 3 to 900 µg per sample, with estimated method detection limits (MDLs) of 5 µg or less. Reported precision estimates, in terms of relative standard deviation, were 0.15 or below at RCS mass per sample of 30 µg. To further optimize the method, matching CRM particle size distribution to that of RCS samples [20] has been applied to minimize the effect of particle size on the IR response. The KBr pellet IR method has been used to measure the crystalline silica content of respirable dusts collected at various workplaces, including coal mines [7,8,22], construction sites [23], granite quarries [9] and gold mines [24]. Laboratories using the KBr disc method have performed successfully in interlaboratory proficiency analytical testing programs [3,25,26].

REFERENCES:

- [1] ACGIH [2017] TLVs and BEIs based on the documentation of the Threshold Limit Values for chemical substances and physical agents and Biological Exposure Indices. Cincinnati, OH: American Conference of Governmental Industrial Hygienists.
- [2] Institute for Occupational Safety and Health of the German Social Accident Insurance (IFA) [2017]. GESTIS international limit values, <http://limitvalue.ifa.dguv.de/>.
- [3] Harper M, Sarkisian K, Andrew M [2014]. Assessment of respirable crystalline silica using Proficiency Analytical Testing results from 2003-2013. *J Occup Environ Hyg* 11:D157-D163.
- [4] NIOSH [2016]. Development and evaluation of methods (Chapter ME). By Kennedy ER, Fischbach TJ, Song R, Eller PM, Hull RD. In: NIOSH manual of analytical methods, 5th ed.; Ashley K, O'Connor PF, eds. Cincinnati, OH: U.S. Department of Health and Human Services, Centers for Disease Control, National Institute for Occupational Safety and Health, DHHS (NIOSH) Publication No. 2014-151.
- [5] Ojima J [2003]. Determining crystalline silica in respirable samples by infrared spectrophotometry in the presence of interferences. *J Occup Health* 45:94-103.
- [6] NIOSH [1977]. Method P&CAM 100 - Quartz in coal dust by infrared spectroscopy. In: Taylor DG, ed. NIOSH manual of analytical methods, 2nd ed. Cincinnati, OH: U.S. Department of Health, Education and Welfare, Center for Disease Control, National Institute for Occupational Safety and Health, DHEW (NIOSH) Publication No. 77-157.
- [7] Larsen DJ, von Loenhoff LJ, Crable JV [1972]. The quantitative determination of quartz in coal dust by infrared spectroscopy. *Am Ind Hyg Assoc J* 33:367-372.
- [8] Dodgson J, Whittaker W [1973]. The determination of quartz in respirable dust samples by infrared spectrophotometry – 1: The potassium bromide disc method. *Ann Occup Hyg* 16:373-387.
- [9] Cares JW, Goldin AS, Lynch JJ, Burgess WA [1973]. The determination of quartz in airborne respirable granite dust by infrared spectrophotometry. *Am Ind Hyg Assoc J* 34:298-305.
- [10] Taylor DG, Nenadic CM, Crable JV [1970]. Infrared spectra for mineral identification. *Am Ind Hyg Assoc J* 31:100-108.
- [11] Talvitie NA [1951]. Determination of quartz in the presence of silicates using phosphoric acid. *Anal Chem* 23:623-626.

- [12] NIOSH [2003]. Determination of airborne respirable silica (Chapter R). By Key-Schwartz RJ, Baron PA, Bartley DL, Rice FL, Schlecht PC. In: NIOSH manual of analytical methods, 4th ed.; Schlecht PC, O'Connor PF, eds. Cincinnati, OH: U.S. Department of Health and Human Services, Centers for Disease Control, National Institute for Occupational Safety and Health, DHHS (NIOSH) Publication No. 94-113.
- [13] NIOSH [2003]. Methods 7603 and 7500. In: NIOSH manual of analytical methods, 4th ed.; Schlecht PC, O'Connor PF, eds. Cincinnati, OH: U.S. Department of Health and Human Services, Centers for Disease Control, National Institute for Occupational Safety and Health, DHHS (NIOSH) Publication No. 94-113.
- [14] ASTM International [2014]. ASTM D7948, Standard test method for measurement of respirable crystalline silica in workplace air by infrared spectrometry. West Conshohocken, PA: ASTM International.
- [15] NIST [no date]. Standard reference materials (SRMs). Gaithersburg, MD: U.S. Department of Commerce, National Institute of Standards and Technology, <https://www.nist.gov>. Date accessed: July 25, 2017. Technology (NIST), Standard Reference Materials (SRMs); www.nist.gov (Accessed August 2016).
- [16] Stacey P, Mecchia M, Verpaele S, Pretorius C, Key-Schwartz R, Mattenklott M [2014]. Differences between samplers for respirable dust and the analysis of quartz – An international study. In: Silica and Associated Respirable Mineral Particles (ASTM STP 1565); Harper M, Lee T, Eds. W. Conshohocken, PA: ASTM International; pp. 73-102.
- [17] Lee T, Lee EG, Kim SW, Chisholm W, Kashon M, Harper M [2012]. Quartz measurement in coal dust with high-flow rate samplers – Laboratory study. *Ann Occup Hyg* 56:413-425.
- [18] ISO [1995]. Air quality – Particle size fraction definitions for health-related sampling. Geneva, Switzerland: International Organization for Standardization.
- [19] Verpaele S, Jouret J [2013]. A comparison of the performance of samplers for respirable dust in workplaces and laboratory analysis for respirable quartz. *Ann Occup Hyg* 57:54–62.
- [20] Stacey P, Kauffer EM, Moulut J-C, Dion C, Beauparlant M, Fernandez P, Key-Schwartz RJ, Friede B, Wake D [2009]. An international comparison of the crystallinity of calibration materials for the analysis of respirable α -quartz using x-ray diffraction and a comparison with results from the infrared KBr disc method. *Ann Occup Hyg* 53:639-649.
- [21] Lee T, Chisholm WP, Kashon M, Key-Schwartz RJ, Harper M [2013]. Consideration of kaolinite interference correction for quartz measurements in coal mine dust. *J Occup Environ Hyg* 10:425-434.
- [22] Bandyopadhyay AK [2010]. Determination of quartz content for Indian coals using an FTIR technique. *Int J Coal Geol* 81:73-87.
- [23] Virji MV, Bello D, Woskie SR, Liu XM, Kalil AJ [2002]. Analysis of quartz by FTIR in air samples of construction *Appl Occup Environ Hyg* 17:165-175.
- [24] Verma DK, Sebestyen A, Julian JA, Muir DCF [1992]. A comparison of two methods of sampling and analysis for free crystalline silica α -quartz. *Appl Occup Environ Hyg* 7:758-763.
- [25] Shulman SA, Groff JH, Abell MT [1992]. Performance of laboratories measuring silica in the Proficiency Analytical Testing program. *Am Ind Hyg Assoc J* 53:49-56.

[26] Stacey P, Tylee B, Bard D, Atkinson R [2003]. The performance of laboratories analyzing α -quartz in the Workplace Analysis Scheme for Proficiency. *Ann Occup Hyg* 47:269-277.

METHOD REVISED BY:

Kevin Ashley, Ph.D., Rosa J. Key-Schwartz, Ph.D., and Martin Harper, Ph.D., CIH, CDC/NIOSH.

Disclaimer: Mention of any company or product does not constitute endorsement by NIOSH. In addition, citations to websites external to NIOSH do not constitute NIOSH endorsement of the sponsoring organizations or their programs or products. Furthermore, NIOSH is not responsible for the content of these websites. All web addresses referenced in this document were accessible as of the publication date.

Table 1. Minerals potentially encountered and their characteristic IR bands (450-1000 cm^{-1})

| Mineral | Major/Interfering Peaks, cm^{-1} | Identifying Peaks, cm^{-1} |
|------------------|---|-------------------------------------|
| Quartz | 800, 780 | 694, 512, 467 |
| Cristobalite | 798 | 623, 490 |
| Tridymite | 789 | 617, 476 |
| Amorphous silica | 800 | 464 |
| Kaolinite | 795, 754 | 915, 547, 474 |
| Muscovite | 800, 750 | 535, 481 |
| Mullite | 837, 748 | 556, 468 |
| Pyrophyllite | 830, 814 | 948, 477, 457 |
| Albite | 788, 746 | 726, 652, 598, 470 |
| Montmorillonite | 797 | 918, 668, 526, 470 |
| Daphnite | 798, 771 | 667, 610, 539, 467 |
| Anorthite | 760, 730 | 577, 538, 481 |
| Orthoclase | 765, 745, 730 | 645, 593, 540 |
| Talc | 797, 778 | 668, 641, 620 |
| Vermiculite | 810, 755 | 685, 510 |



QUARTZ in Respirable Coal Mine Dust, by IR (Redeposition) 7603

SiO₂

MW: 60.08

CAS: 14808-60-7

RTECS: VV7330000 (quartz)

METHOD: 7603, Issue 4

EVALUATION: FULL

Issue 1: 15 May 1989

Issue 4: 25 July 2017

OSHA: 0.05 mg/m³

NIOSH: 0.05 mg/m³; suspect carcinogen

OTHER OELS: [1,2]

PROPERTIES: solid; d 2.65 g/cm³; crystalline transformation: α-quartz to β-quartz @ 573 °C; quartz to tridymite @ 867 °C

SYNONYMS: free crystalline silica; silicon dioxide

| SAMPLING | | MEASUREMENT | |
|--|--|--|--|
| SAMPLER: | CYCLONE + PREWEIGHED FILTER (PVC), with conductive filter holder | TECHNIQUE: | INFRARED SPECTROMETRY |
| FLOW RATE: | ~2 to ~4 L/min, specific for the cyclone used | ANALYTE: | Quartz |
| VOL-MIN: | 300 L @ 0.1 mg/m ³ | ASHING: | Muffle furnace or RF plasma asher |
| -MAX: | 1000 L (total dust < 4 mg) | REDEPOSIT: | Polypropylene filter (47 mm, 0.45 μm pore size) [3] |
| SHIPMENT: | Routine | IR DETECTION: | Scan absorbance between 450 cm ⁻¹ and 1000 cm ⁻¹ |
| SAMPLE STABILITY: | Stable | CALIBRATION: | Primary certified reference material quartz, e.g., NIST SRM 1878b, suspended in 2-propanol; or NIST SRM 2950a (quartz on filter) |
| BLANKS: | 3 field blanks minimum per sample set | RANGE: | 10 to 500 μg quartz per sample [3-5,7] |
| ACCURACY | | ESTIMATED LOD: | 1 μg [3,4] |
| RANGE STUDIED: | <10 to ~500 μg per sample [3-6] | PRECISION (\bar{S}_r): | 0.004 to 0.10 @ 50 to 250 μg per sample [3-6] |
| BIAS: | Negligible when matrix effects are accounted for | | |
| OVERALL PRECISION ($\hat{S}_{r,T}$): | 0.07 to 0.10 [3-7] | | |
| ACCURACY: | ±17% to ±33% [5-7] | | |

APPLICABILITY: The working range is 0.01 to 0.50 mg/m³ for a 1000-L air sample [3,5-7]. The method was originally developed specifically for respirable coal mine dust samples [6,8-10]. IR is useful for a matrix such as coal mine dust, where the interferences can be predictably removed and minimized.

INTERFERENCES: Amorphous silica, kaolinite, muscovite, talc, albite, vermiculite and other minerals that absorb IR radiation in the 800 cm⁻¹ region are potential interferences to RCS measurement [11,12] [Table 1]. Potentially interfering silicates can be removed using a phosphoric acid cleanup procedure [13]. Calcite at >20% dust loading can negatively interfere by reacting with quartz during muffle ashing [10,14]. The sample preparation procedures described in this method enable minimization of potential interferences.

OTHER METHODS: NIOSH Method 7602 describes sample preparation and IR measurement of respirable crystalline silica (RCS) by means of a KBr pellet [15]. X-ray diffraction (e.g., NIOSH Method 7500 [15]) is a complementary method for quartz measurement by IR. MSHA Method P-7 [6] is an equivalent IR method for respirable quartz. An international voluntary consensus standard describing the measurement of RCS by IR spectrometry, ASTM D7439, has been promulgated [16].

REAGENTS:

1. Quartz primary certified reference material (CRM); e.g., NIST SRM 1878b or SRM 2950a [17].
2. Kaolinite CRM; e.g., material meeting requirements from USP[#]
3. Deionized water, ≥ 18 M Ω -cm resistivity.
4. 2-Propanol, reagent grade.
5. Ethanol, 95%, for cleaning of sampling equipment.*
6. Hydrochloric acid* (HCl) solution, 25% v/v: Add 25 mL conc. HCl (37% w/w) to 50 mL with deionized water, cool, and bring to 100 mL with deionized water.
NOTE: Required if calcite is present and samples are prepared using a muffle furnace.
7. Calibration stock solution (quartz suspension in 2-propanol), 15 mg/L: Accurately weigh 7.5 mg of quartz and add to about 400 mL of 2-propanol in a 500-mL volumetric flask. Bring the suspension to the mark with 2-propanol.
8. Kaolinite suspension, 100 mg/mL: Accurately weigh 50 mg of dried kaolinite and add to about 400 mL of 2-propanol in a 500-mL volumetric flask. Bring the suspension to the mark with 2-propanol.
NOTE: Not required if muffle furnace used for sample ashing.
9. Desiccant.
10. Oxygen, purified.

[#]United States Pharmacopeia Convention

*See SPECIAL PRECAUTIONS.

EQUIPMENT:

1. Sampler:
 - a. Filters, 37-mm dia., 5- μ m pore size, polyvinyl chloride (PVC), supported with backup pad or screen in 2-piece, conductive / static-dissipative filter holder.
 - b. Cyclone, respirable, designed to operate at a flow rate of ≈ 2 or ≈ 4 L/min, specific for each sampling device.
 - c. Sampling head holder, for keeping the cassette, cyclone and coupler tightly together so that air enters only through cyclone inlet.
2. Personal sampling pumps, for sample collection at ≈ 2 or ≈ 4 L/min.
3. Infrared spectrometer, double-beam dispersive or Fourier transform device, with 4 cm^{-1} resolution or better.
4. Filtration apparatus (for redepositing sample after ashing), consisting of fritted support, side-arm vacuum flask and glass filtration funnel with bakelite base, 1.0 cm internal diameter. The base should seal tightly to the fritted support to prevent leakage.
5. Filters for standards and redeposition, 47-mm, 0.45- μ m pore size, polypropylene (PP).
6. Glass fiber filters, 25-mm dia., for backup during filtration.
7. Filtration funnel for treating filters (required only if using a muffle furnace): same as in 6. above except with funnel i.d. about 1.6 cm and with 0.5- μ m pore size 37-mm dia. PVC filters to recollect residue.
8. Low-temperature (RF plasma) asher and aluminum weighing pan, or muffle furnace and 10-mL porcelain crucibles (with covers).
9. Analytical balance, capable of weighing to the nearest 0.001 mg.
10. Ultrasonic bath.
11. Desiccator.
12. Beakers, 50-mL.
13. Magnetic stirrer with insulated top.
14. Volumetric flasks with stoppers, 500-mL.
15. Tweezers and metal spatulas.
16. Petri dishes, for 47-mm dia. filters.
17. Wash bottles.
18. Pipets, various sizes as required.

SPECIAL PRECAUTIONS: Wear appropriate personal protection during sampling activities, sample preparation and analysis. It is essential that suitable gloves, eye protection, laboratory coat, etc., be used, especially when working with concentrated acids. Ethanol and 2-propanol are flammable. Avoid exposure by inhalation of silica dust or acid fumes. Perform sample preparation and analysis in a clean, well-ventilated area that is well removed from any possible contamination. Any skin affected by exposure to acids must be immediately washed with plenty of water.

SAMPLING:

1. Calibrate each personal sampling pump with a representative sampler in line. Use conductive filter holders.
2. Pre-weigh each filter to the nearest 0.01 mg.
3. Sample at ≈ 2 L/min [18] or ≈ 4 L/min [5] using a pump set at a specific flow rate for a selected cyclone, designed to collect the respirable aerosol fraction (in accordance with ISO 7708[19]), for a total sample size of 400 to 1000 L. Take care not to overload the filter.

NOTE 1: Do not allow the sampler assembly to be inverted at any time when using a cyclone. Turning the cyclone to anything more than a horizontal orientation may deposit oversized material from the cyclone body onto the filter.

NOTE 2: Higher sampling flow rates may be suitable for certain sampler designs [20].

4. After collection of samples, remove the filter holders from the cyclones. Seal the filter holders (cassettes) and transport them to the laboratory in a container designed to prevent damage in transit.

SAMPLE PREPARATION:

5. Remove the filters from filter holders and, after preconditioning to ambient conditions, re-weigh the filters to the nearest 0.01 mg; the difference is the sample weight, W_s (μg).
6. Use one of the following methods to prepare samples and blanks:
 - a. Low-temperature (RF plasma) asher: Transfer the weighed filters to clean 50-mL beakers. Place the beakers in the low-temperature asher so that sample exposure to the plasma is optimized. Ash the samples for 2 h at 300 W RF power and oxygen flow rate of 75 mL/min, according to manufacturer's instructions. Carefully bring the asher to atmospheric pressure, remove the beakers, and add 15 mL 2-propanol to each beaker.
 - b. Muffle furnace: For samples expected to contain a significant amount of calcite (>20% of the total dust loading), wash filters with 25% v/v HCl using the filtration apparatus with the 1.6-cm i.d. glass funnel. For other samples, proceed to step 6.b.ii.
 - i. Place a 25-mm glass fiber filter over the frit area of the filtration funnel, then place a 0.45- μm pore size, 37-mm dia. PP filter atop the glass fiber filter. Clamp the funnel over the frit and ensure that there is no leakage. Using tweezers and gloved hands, take the weighed sample filter and fold it in half with the collection surface inside, then fold again into quarters, and place the folded filter into the funnel. Add 10 mL of 25% HCl (v/v), then 5 mL of 2-propanol; allow to stand for 5 min. Apply vacuum and slowly aspirate the acid and alcohol in the funnel. Press the folded sample filter onto the surface of the collection filter if necessary to remove all liquid. Release vacuum, remove both filters and place in a porcelain crucible. Allow to air-dry.
 - ii. Place filter samples and blanks in porcelain crucibles, loosely cover, and ash in muffle furnace for 2 h at 600 °C (800 °C if graphite present). Allow to cool to room temperature.
 - iii. Add ~ 3 mL 2-propanol to the ash within each crucible, scrape the crucible to loosen all particles, and quantitatively transfer to contents to a 50-mL beaker. Wash the crucible several times with 2-propanol and add the wash to the beaker. Add 2-propanol to the beaker to bring the volume to ~ 15 mL.
7. Redeposit the sample residue as follows, using the filtration apparatus with the 1.0 cm dia. funnel. With a slight vacuum applied, place a 25-mm glass fiber filter on the fritted base. Cut a 47-mm 0.45- μm PP filter in half. Superimpose one half over the other, glossy sides down, and place on the

glass fiber filter. (The lower half of the PP filter serves as a blank for use in the reference beam of the IR spectrometer.) Position the filter funnel, apply clamp, turn off vacuum and ensure that there is no leakage. Place sample beakers from step 6.b.iii into ultrasonic bath for at least 30 sec to ensure homogeneous dispersion. Remove each beaker, wipe off excess water from the outside of the beaker, and transfer the slurry to the filtration funnel. Reapply vacuum and, during filtration, rinse the beaker twice with 2-propanol to ensure quantitative transfer of entire contents to the funnel. Control the filtration rate to keep the liquid near the top of the funnel during rinsing to avoid disturbing the deposit. When the depth of liquid in the funnel reaches about 4 cm above the filter, gently rinse the inside of the funnel with 2-propanol and complete filtration. Remove clamp and funnel, taking care not to disturb the deposit. Release the vacuum. Define the deposit area by marking around the circumference using a pencil or scribe. (This is especially important for standards or light-colored samples.) Place the PP filter halves in Petri dishes and allow to air dry.

CALIBRATION AND QUALITY CONTROL:

8. Prepare at least 5 working standard quartz filters. Calibration standards shall be prepared from primary CRMs of known purity, particle size range and homogeneity.

NOTE: Suitable quartz standards include primary reference materials such as NIST SRM 1878b or 2950; the use of secondary reference materials as calibration standards is not appropriate for IR measurement [14].

- a. Place the flask containing the calibration stock solution in an ultrasonic bath for 30-45 min.
- b. Move the flask to a magnetic stirrer and stir slowly while the flask cools to room temperature. Continue slow stirring while preparing calibration standards.
- c. Mount a PP filter in the filtration apparatus in the same manner used to redeposit the samples. Add 5 mL of 2-propanol to the funnel. Withdraw an aliquot of the quartz suspension from the center of the flask. Draw liquid to the mark but do not attempt to adjust volume by draining pipet. Carefully wipe the outside of the pipet, then drain the suspension into the filter funnel. Rinse down the inside wall of the pipet with a few mL of 2-propanol, draining the washings into the funnel. Apply vacuum to complete the filtration. Prepare quartz standards in this manner to cover the range 10 to 250 μg per filter.
- d. Carry an additional set of these calibration standards and media blanks through steps 6 and 7 to monitor for contamination and losses.

NOTE: Accuracy depends on obtaining uniform deposition of samples and calibration standards across the filter surface and obtaining reproducible aliquots from the quartz suspension. This requires skill and practice. The quartz calibration curve should be prepared before analyzing samples as a check on the analyst's ability to prepare uniform deposits. Repeatability should be <10% on replicate calibration standards with >40 μg of quartz.

9. Perform IR scans for each standard filter using the other half of the filter in the reference beam (see Measurement section). Construct a calibration graph of absorbance at 800 cm^{-1} vs. μg of quartz per filter. The plot should be linear and pass through the origin.
 10. If samples were low-temperature ashed and kaolinite is known to be present in the matrix of the collected samples, prepare at least five different loadings of PP filters containing 100 to 600 μg of kaolinite. Measure the IR absorbance of kaolinite standards from 1000 cm^{-1} to 650 cm^{-1} . Prepare a graph with absorbance at 915 cm^{-1} as ordinate vs. absorbance at 800 cm^{-1} as abscissa. Use the relationship between the quartz and kaolinite peak to correct the absorbance value at 800 cm^{-1} samples containing kaolinite [20].
 11. Carry media blanks and filters spiked with known amounts of quartz through the sample preparation procedures to monitor for contamination and losses.
- NOTE: Knowledge of and training in geochemistry and mineralogy is strongly recommended for users of this method. Although many analytical chemists are familiar with IR spectroscopy (e.g., as applied to organic analysis), mineralogical samples such as those containing RCS require

additional knowledge of geochemistry and mineralogy to correctly interpret IR spectra and account for matrix interferences and mineral transformations.

MEASUREMENT:

12. Set the infrared spectrometer to double-beam absorbance mode and to the appropriate settings for quantitative analysis. For each IR scan, place a PP sample filter half in the sample beam and a PP blank filter half in the reference beam, and obtain a spectrum at 4 cm⁻¹ resolution or better from 450 cm⁻¹ to 1000 cm⁻¹. For each PP filter sample, center the IR beam on filter deposit.
13. Draw an appropriate baseline under the absorbance band at 800 cm⁻¹ from approximately 820 to 670 cm⁻¹. Measure the absorbance from the 800 cm⁻¹ peak maximum to baseline in absorbance units.
NOTE: If the peak at 800 cm⁻¹ is small, expand the ordinate to enhance the peak height.
14. If the sample was ashed at low temperature, the presence of kaolinite will be indicated by an absorption band with maximum at 915 cm⁻¹. Draw an appropriate baseline under the absorbance band at 915 cm⁻¹ from approximately 960 to 860 cm⁻¹. Measure the absorbance from the 915 cm⁻¹ peak maximum to baseline.
15. Analyze blanks and, if necessary, correct baseline.

CALCULATIONS:

16. To correct for the presence of kaolinite (if necessary), use the measured absorbance at 915 cm⁻¹ and refer to the kaolinite curve to establish the corrected absorbance for quartz at 800 cm⁻¹ [21]. Use this corrected absorbance value at 800 cm⁻¹ in calculating the airborne quartz concentration.
17. If correction for kaolinite is not required, use the measured (uncorrected) absorbance at 800 cm⁻¹ to determine the weight (W_s , μg) quartz from the calibration graph.
18. From the weight of quartz (W_s , μg), calculate its concentration, C (mg/m³), in the volume of air sampled, V (L):

$$C = [W_s / V], \text{ mg/m}^3$$

19. If percent quartz (%Q) is of interest, divide the weight of quartz, W_s (μg), by the total sample weight, W_t (μg):

$$\%Q = [W_s / W_t] \times 100$$

EVALUATION OF METHOD:

The method is based on MSHA method P-7, which was collaboratively tested [4] and optimized [6]. Interlaboratory evaluation included a ruggedization step to test the effects of the use of muffle furnace or plasma asher, amount of calcite or kaolinite in the sample, ashing time, pH of solvent used to remove calcite, shipment of samples, and other factors. None of these contributions was found to have a statistically significant effect. Filter collection has been carried out using respirable cyclone samplers with flow rate ≈ 2 L/min [4] and ≈ 4 L/min [5], with sampling volumes ranging from 300 to 1000 L; analysis was subsequently carried out using the redeposition method. Applicable analytical ranges were from 3 μg [5] to 500 μg quartz [4,6] per sample, with estimated method detection limits (MDLs) of 1-5 μg or even less [3]. Reported precision estimates, in terms of relative standard deviation, were 0.10 or below at quartz mass per sample of 20-400 μg [3-6]. The IR redeposition method has been used extensively to measure the quartz content of respirable dusts collected in coal mines [3,8-10,21,22]. Laboratories using the IR redeposition method have performed successfully in interlaboratory proficiency analytical testing programs [7, 23, 24].

REFERENCES:

- [1] ACGIH [2017] TLVs and BEIs based on the documentation of the Threshold Limit Values for chemical substances and physical agents and Biological Exposure Indices. Cincinnati, OH: American Conference of Governmental Industrial Hygienists.
- [2] Institute for Occupational Safety and Health of the German Social Accident Insurance (IFA) [2017]. GESTIS international limit values, <http://limitvalue.ifa.dguv.de/>.
- [3] Farcas D, Lee T, Chisholm WP, Soo J-C, Harper M [2016]. Replacement of filters for respirable quartz measurement in coal mine dust by infrared spectroscopy. *J Occup Environ Hyg* 13:D17-D22.
- [4] Anderson CC [1983]. Collaborative test of two methods for determining free silica in airborne dust. Cincinnati, OH: U.S. Department of Health and Human Services, Centers for Disease Control, National Institute for Occupational Safety and Health, DHHS (NIOSH) Publication No. 83-124.
- [5] Lee T, Lee EG, Kim SW, Chisholm WP, Kashon M, Harper M [2012]. Quartz measurement in coal dust with high flow rate samplers – Laboratory study. *Ann Occup Hyg* 56:413-425.
- [6] Mine Safety and Health Administration (MSHA) [2013]. Infrared determination of quartz in respirable coal mine dust; Method No. P-7. Pittsburgh, PA: MSHA.
- [7] Harper M, Sarkisian K, Andrew M [2014]. Assessment of respirable crystalline silica using Proficiency Analytical Testing results from 2003-2013. *J Occup Environ Hyg* 11:D157-D163.
- [8] Larsen DJ, von Loenhoff LJ, Crable JV [1972]. The quantitative determination of quartz in coal dust by infrared spectroscopy. *Am Ind Hyg Assoc J* 33:367-372.
- [9] Freedman RW, Toma SZ, Lang HW [1974]. On-filter analysis of quartz in respiratory coal dust by infrared absorption and x-ray diffraction. *Am Ind Hyg Assoc J* 35:411-418.
- [10] NIOSH [1977]. Method P&CAM 100 - Quartz in coal dust by infrared spectroscopy. In: Taylor DG, ed. NIOSH manual of analytical methods, 2nd ed. Cincinnati, OH: U.S. Department of Health, Education and Welfare, Center for Disease Control, National Institute for Occupational Safety and Health, DHEW (NIOSH) Publication No. 77-157.
- [11] Taylor DG, Nenadic CM, Crable JV [1970]. Infrared spectra for mineral identification. *Am Ind Hyg Assoc J* 31:100-108.
- [12] Ojima J [2003]. Determining crystalline silica in respirable samples by infrared spectrophotometry in the presence of interferences. *J Occup Health* 45:94-103.
- [13] Talvitie NA [1951]. Determination of quartz in the presence of silicates using phosphoric acid. *Anal Chem* 23:623-626.
- [14] NIOSH [2003]. Determination of airborne respirable silica (Chapter R). By Key-Schwartz RJ, Baron PA, Bartley DL, Rice FL, Schlecht PC. In: NIOSH manual of analytical methods, 4th ed.; Schlecht PC, O'Connor PF, eds. Cincinnati, OH: U.S. Department of Health and Human Services, Centers for Disease Control, National Institute for Occupational Safety and Health, DHHS (NIOSH) Publication No. 94-113.
- [15] NIOSH [2003]. Methods 7603 and 7500. In: NIOSH manual of analytical methods, 4th ed.; Schlecht PC, O'Connor PF, eds. Cincinnati, OH: U.S. Department of Health and Human Services, Centers for Disease Control, National Institute for Occupational Safety and Health, DHHS (NIOSH) Publication No. 94-113.

- [16] ASTM International [2014]. ASTM D7948, Standard test method for measurement of respirable crystalline silica in workplace air by infrared spectrometry. West Conshohocken, PA: ASTM International.
- [17] NIST [no date]. Standard reference materials (SRMs). Gaithersburg, MD: U.S. Department of Commerce, National Institute of Standards and Technology, <https://www.nist.gov>. Date accessed: July 25, 2017.
- [18] Stacey P, Mecchia M, Verpaele S, Pretorius C, Key-Schwartz R, Mattenklott M [2014]. Differences between samplers for respirable dust and the analysis of quartz – An international study. In: Silica and associated respirable mineral particles (ASTM STP 1565); Harper M, Lee T, eds. W. Conshohocken, PA: ASTM International; pp. 73-102.
- [19] ISO [1995]. Air quality – Particle size fraction definitions for health-related sampling. Geneva, Switzerland: International Organization for Standardization.
- [20] Verpaele S, Jouret J [2013]. A comparison of the performance of samplers for respirable dust in workplaces and laboratory analysis for respirable quartz. *Ann Occup Hyg* 57:54–62.
- [21] Lee T, Chisholm WP, Kashon M, Key-Schwartz RJ, Harper M [2013]. Consideration of kaolinite interference correction for quartz measurements in coal mine dust. *J Occup Environ Hyg* 10:425-434.
- [22] Ainsworth, SM [2005]. Infrared analysis of respirable coal mine dust for quartz: Thirty five years. *J ASTM Int* 2(4):1-13, DOI: 10.1520/JAI12231.
- [23] Shulman SA, Groff JH, Abell MT [1992]. Performance of laboratories measuring silica in the Proficiency Analytical Testing program. *Am Ind Hyg Assoc J* 53:49-56.
- [24] Stacey P, Tylee B, Bard D, Atkinson R [2003]. The performance of laboratories analyzing α -quartz in the Workplace Analysis Scheme for Proficiency. *Ann Occup Hyg* 47:269-277.

METHOD REVISED BY:

Kevin Ashley, Ph.D., Rosa J. Key-Schwartz, Ph.D., and Martin Harper, Ph.D., CIH, CDC/NIOSH.

Disclaimer: Mention of any company or product does not constitute endorsement by NIOSH. In addition, citations to websites external to NIOSH do not constitute NIOSH endorsement of the sponsoring organizations or their programs or products. Furthermore, NIOSH is not responsible for the content of these websites. All web addresses referenced in this document were accessible as of the publication date.

Table 1. Minerals potentially encountered and their characteristic IR bands (450-1000 cm⁻¹)

| Mineral | Major/Interfering Peaks, cm⁻¹ | Identifying Peaks, cm⁻¹ |
|------------------|---|---|
| Quartz | 800, 780 | 694, 512, 467 |
| Cristobalite | 798 | 623, 490 |
| Tridymite | 789 | 617, 476 |
| Amorphous silica | 800 | 464 |
| Kaolinite | 795, 754 | 915, 547, 474 |
| Muscovite | 800, 750 | 535, 481 |
| Mullite | 837, 748 | 556, 468 |
| Pyrophyllite | 830, 814 | 948, 477, 457 |
| Albite | 788, 746 | 726, 652, 598, 470 |
| Montmorillonite | 797 | 918, 668, 526, 470 |
| Daphnite | 798, 771 | 667, 610, 539, 467 |
| Anorthite | 760, 730 | 577, 538, 481 |
| Orthoclase | 765, 745, 730 | 645, 593, 540 |
| Talc | 797, 778 | 668, 641, 620 |
| Vermiculite | 810, 755 | 685, 510 |



CHROMIUM, HEXAVALENT by Ion Chromatography

7605

Cr(VI) MW: 52.00 (Cr); 99.99 (CrO₃) CAS: 18540-29-9 RTECS: GB6262000

METHOD: 7605, Issue 2

EVALUATION: FULL

Issue 1: 15 March 2003

Issue 2: 10 March 2016

OSHA: 0.005 mg/m³ (1910.1026); C 0.1 mg/m³ as CrO₃ (exceptions to 1910.1026)

PROPERTIES: oxidizing agent

NIOSH: 0.0002 mg/m³ (8h); carcinogen

SYNONYMS: Vary depending upon the compound; chromate commonly used; "chrome six."

| SAMPLING | | MEASUREMENT | |
|---|--|--|--|
| SAMPLER: | FILTER (5.0- μ m PVC membrane) | TECHNIQUE: | Ion chromatography with post-column derivatization and UV detection. |
| FLOW RATE: | 1 to 4 L/min | ANALYTE: | CrO ₄ ²⁻ -diphenylcarbazide (DPC) complex |
| VOL-MIN: | 1 L @ 0.05 mg/m ³ | EXTRACTION: | 5 mL 2% NaOH- 3% Na ₂ CO ₃ . Dilute to 25 mL after heating. |
| -MAX: | 400 L | INJECTION VOLUME: | 100 μ L |
| SHIPMENT: | Routine. Can be shipped cold when deemed necessary | COLUMN: | Dionex NG1 Guard, HPIC- AS7 Separator or equivalent |
| SAMPLE STABILITY: | Stable for 2 weeks at room temperature. Stable for 4 weeks if stored in refrigerator. | MOBILE PHASE: | 250 mM (NH ₄) ₂ SO ₄ /100 mM NH ₄ OH |
| BLANKS: | 2 to 10 field blanks per set | FLOW RATE: | 1.0 mL/min; 0.7 mL/min post column |
| ACCURACY | | POST-COLUMN REAGENT: | 2.0 mM DPC + 10% MeOH +1N H ₂ SO ₄ |
| RANGE STUDIED: | 0.05 to 120 μ g Cr(VI) [1,2] | DETECTOR: | UV @ 540 nm |
| BIAS: | -1.6% [2] | CALIBRATION: | Standard solutions of K ₂ Cr ₂ O ₇ in NaOH-Na ₂ CO ₃ buffer |
| OVERALL PRECISION (\hat{S}_{rT}): | 0.07 | RANGE: | 0.05 to 20 μ g per sample |
| ACCURACY: | \pm 17.4% (0.6 - 960 g/m ³) [1] | ESTIMATED LOD: | 0.02 μ g per sample [3] |
| | | PRECISION (\bar{S}_r): | 0.015 @ 0.5 to 5 μ g/sample [3] |

APPLICABILITY: The working range is 0.00025 to 0.1 mg/m³ for a 200-L air sample. This method can be used for the determination of Cr(VI) using 2% NaOH - 3% Na₂CO₃ for extraction.

INTERFERENCES: Possible interferences are iron, copper, nickel, and vanadium; 10 μ g of any of these causes an absorbance equivalent to approximately 0.02 μ g Cr(VI) due to formation of colored complexes. Interference due to reducing agents (e.g., Fe, Fe⁺⁺) is minimized by alkaline extraction (step 5).

OTHER METHODS: Method 7703 is a field portable method for Cr(VI). OSHA Method W4001 is for the measurement of Cr(VI) in wipe samples [4]. OSHA Method ID-215 is applicable to measurement of Cr(VI) and employs precipitation to reduce Cr(III) oxidation. [5]. A similar air method is ISO 16740 [6]. EPA Method 218.6 is for water matrices [7]. Method 7604 is also specific for hexavalent chromium, using ion chromatography, but has a higher detection limit than 7605.

REAGENTS:

1. Sulfuric acid, conc. (98 % w/w).*
2. Ammonium hydroxide, conc. (28 %).*
3. Ammonium sulfate monohydrate, reagent grade.
4. Sodium carbonate, anhydrous.
5. Sodium hydroxide, reagent grade.*
6. Methanol, HPLC grade.*
7. 1,5-Diphenylcarbazide, reagent grade.
8. Potassium dichromate or potassium chromate.* Dry at 100 °C and store in a desiccator.
9. Post-Column Derivatizing Reagent:
Diphenylcarbazide solution. Dissolve 500 mg 1,5-diphenylcarbazide in 100 mL HPLC-grade methanol. While stirring, add 500 mL water containing 28 mL of conc. sulfuric acid. Dilute to a final volume of one liter with water. This reagent is stable for 4 - 5 days. Prepare in one-liter quantities, as needed.
10. Cr(VI) standard, 1000 µg/mL. Dissolve 2.829 g potassium dichromate in deionized water to make one liter, or use commercially available solution.
NOTE: 3.731 g K₂CrO₄ can also be used.
11. Calibration stock solution, 1.0 µg/mL. Dilute 1000 µg/mL Cr(VI) standard 1 :1000 with deionized water.
12. Filter extraction solution, 2% NaOH-3% Na₂CO₃. Dissolve 20 g NaOH and 30 g Na₂CO₃ in deionized water to make one liter of solution.
13. Eluent (mobile phase); 250 mM ammonium sulfate/200 mM ammonium hydroxide. Dissolve 33 g ammonium sulfate in approximately 500 mL distilled water and add 6.5 mL conc. ammonium hydroxide. Dilute to one liter with distilled water and mix.
14. Nitrogen, pre-purified.

*See SPECIAL PRECAUTIONS.

EQUIPMENT:

1. Sampler: polyvinyl chloride (PVC) filter, 5.0- µm pore size, 37 -mm diameter in polystyrene cassette filter holder.
NOTE: Some PVC filters promote reduction of Cr(VI). Check each lot of filters for recovery of Cr(VI) standard.
2. Personal sampling pump, 1 to 4 L/min, with flexible connecting tubing.
3. Vials, scintillation, 20-mL glass, polytetrafluoroethylene (PTFE)-lined screw cap.**
4. Forceps, nonmetallic.
5. Gloves, polypropylene or latex.
6. Liquid chromatography apparatus consisting of autosampler; pump; columns ; post-column reagent delivery system with 2.2-m high pressure tubing mixing/reaction loop with 1 min a water bath at 32 °C ± 3 °C; and UV detector.
7. Columns: NG1 (Dionex Corp.) or equivalent guard column; HPIC-AS7, 4 x 250-mm (Dionex Corp.) separator column (or equivalent);
8. Filtration apparatus, PTFE luer lock style filter syringe.
9. Beakers, borosilicate, 50 -mL.**
10. Watchglass.**
11. Volumetric flasks, 25-, 100-, and 1000-mL.**
12. Oven at 107°C, not to exceed 115°C.
NOTE: Hot plate or ultrasonic bath can be used.
13. Micropipettes, 10-µL to 0.5-mL.
14. Pipettes, TD 5-mL.**
15. Bagged refrigerant.

**Clean all glassware with 1:1 HNO₃:H₂O and rinse thoroughly before use

SPECIAL PRECAUTIONS: Many chromate compounds are suspected human carcinogens [8]. All sample preparation should be performed in a hood. Concentrated acids and bases are toxic and corrosive. When working with concentrated acids and bases, wear protective clothing. Ammonium hydroxide is a respiratory irritant. Methanol is flammable and toxic.

SAMPLING:

1. Calibrate the sampling pump with a representative sampler in line.
2. Sample at an accurately known flow rate in the range 1 to 4 L/min for a sample size of 1 to 400 L. Do not exceed 1 mg total dust loading on the filter.
3. Filters can be left in the cassettes for shipping to the lab, but to minimize sample contamination during shipping, remove the filter from the cassette within one hour of completion of sampling and place it in a vial to be shipped to the laboratory. Handle the filter only with gloved hands and nonmetallic forceps. Discard the backup pad. As a precaution, it is recommended to ship the samples with bagged refrigerant.

SAMPLE PREPARATION:

4. Don a clean pair of disposable plastic gloves (to prevent sample contamination). Using forceps, transfer the PVC filter to a 50-mL beaker, and add 5.0 mL filter extraction solution, 2% NaOH/3% Na₂CO₃. Start media blanks at this point.
NOTE 1: If significant amounts of Cr[III] are expected to be present in the samples, either (a) degas the sodium hydroxide/sodium carbonate extraction solution by bubbling nitrogen through it for 5 min. before proceeding, or (b) use a precipitation reagent [1].
NOTE 2: If only soluble chromates are of interest, use ammonium sulfate buffer in place of carbonate extraction solution [9,10].
5. Cover the beaker with a watchglass and heat it to near the boiling point (100°C to 115°C) in an oven with occasional swirling for 45 min. Do not boil the solution. Longer heating times (up to 90 minutes) may be necessary for some samples (e.g., paint spray). Do not allow the solution to evaporate to dryness because hexavalent chromium may be lost due to reaction with the PVC filter and/or co-collected aerosol constituents. An indication that hexavalent chromium has been lost in this manner is a brown-colored PVC filter.
NOTE: A hot plate, heater block, or ultrasonic bath can also be used for this step [9,11].
 - a. Cool the solution and transfer it quantitatively with distilled water rinses to a 25-mL volumetric flask. Bring to volume with distilled water.
NOTE: If the solution is cloudy, filter an aliquot through a PTFE luer lock style filter attached to a syringe.
 - b. Transfer an aliquot of the solution to the appropriate vial for the chromatograph's autosampler and analyze (steps 9 through 13).

CALIBRATION AND QUALITY CONTROL:

6. Calibrate daily with at least six working standards. Transfer 5 mL of extraction solution to each of a series of 25-mL volumetric flasks. Pipet known volumes (0 to 5 mL) of calibration stock solution (1.0 µg/mL) into the volumetric flasks. For higher standards, pipet 10 - 20 µL of the 1000 µg/mL concentrated stock and bring the volume to 25 mL with distilled water. These working standards contain 0 to 20 µg Cr(VI) per sample.
7. Analyze the working standards together with blanks and samples (steps 9 through 13).
8. Prepare a calibration graph [instrument response vs. µg Cr(VI)].

MEASUREMENT:

9. Set wavelength on the detector to 540 nm.
10. Set the liquid chromatograph to manufacturer's recommendations and parameters given on page 7605-1. With a mobile phase flow rate of 1.0 mL/min., a post-column reagent flow rate of 0.7 mL/min., and a 2.2-m post-column tube, the derivative retention time should be approximately 3.7 - 4.7 minutes.

NOTE: If the instrument response for the samples is higher than the standards, dilute using a 1:5 dilution of extraction solution:water to maintain a constant ionic strength; repeat the analysis; and multiply the measured concentration by the appropriate dilution factor. Alternatively, inject a smaller volume and multiply by the appropriate factor.

11. After the analysis is complete, flush the entire system with ASTM Type II water for at least one hour at mL/min. with all columns on line. Remove the columns and continue flushing for an additional two hours. Flush the autosampler with several injections of water. Leaving the columns in line while the system is idle is not recommended.

CALCULATIONS

12. From the calibration graph, determine the mass of Cr(VI) in each sample, W (μg), and in the average blank, B (μg).
13. Calculate concentration, C (mg/m^3), of Cr(VI) in the air volume sampled, V (L):

$$C = \frac{W - B}{V}, \text{mg}/\text{m}^3$$

NOTE: $\mu\text{g}/\text{L} \cong \text{mg}/\text{m}^3$

EVALUATION OF METHOD:

This method was evaluated in the laboratory with spiked filters and a certified reference material containing a known loading of Cr(VI). This certified reference material (CRM) is European Commission, Institute for Reference Materials and Measurements (EC/IRMM) CRM 545, Cr(VI) and Cr(total) in welding dust loaded on a glass fiber filter [12]. This method was evaluated for extraction efficiency over the concentration range of 0.15 - 5 $\mu\text{g}/\text{sample}$ testing two brands of filters, SILICAL[®] and GLA-5000[™][3]. In these experiments, test atmospheres were not generated; instead, Cr(VI) as the dichromate was fortified on the face of the sample filters, then 240 L of air with 35% relative humidity was pulled through at 1 L/min. A 30-day storage study using both types of filters was conducted at 1.5 $\mu\text{g}/\text{sample}$ (30x LOQ) at ambient room temperature and 4 °C. The average recovery of the stored samples was 94.8%. The estimation of the limit of detection and limit of quantitation (LOD/LOQ) were determined analyzing a series of liquid standards. The LOD and LOQ, 0.02 $\mu\text{g}/\text{sample}$ and 0.07 $\mu\text{g}/\text{sample}$, respectively were calculated by Burkart's method [13].

To fully evaluate this method, a field-study was conducted in which side-by-side samples were taken to measure exposures to Cr(VI) during spray-painting and electroplating operations. These samples were analyzed subsequently by 4 different methods (NIOSH Method 7605, 7703, 7300 and OSHA ID-215) [1]. NIOSH method 7300 was used to measure total chromium. The results from the other 3 methods correlated very well showing no statistical difference among the 3 methods. Recoveries of 98.4 (± 3.4) % were obtained for CRM 545 ($n = 6$) [2].

REFERENCES:

- [1] Boiano JM, Wallace ME, Sieber WK, Groff JH, Wang J, Ashley K [2000]. Comparison of three sampling and analytical methods for the determination of airborne hexavalent chromium. *J Environ Monit* 2:329- 333.
- [2] Ashley K, Andrews RN, Cavazos L, Demange M [2001]. Ultrasonic extraction as a sample preparation technique for elemental analysis by atomic spectrometry. *J Anal At Spectrom* 16:1147-1153.
- [3] Foote P, Wickman DC, Perkins JB [2002]. Back-up data report for determination of hexavalent chromium by HPLC with post-column derivatization, prepared under NIOSH Contract 2000-95-2955. Unpublished.

- [4] Eide ME [2000]. Hexavalent Chromium, Method No. W 4001. Salt Lake City, Utah: U.S. Department of Labor (USDOL), Occupational Safety and Health Administration (OSHA), Salt Lake Technical Center.
- [5] Ku JC, Eide M [1998]. Hexavalent chromium in the workplace atmosphere, OSHA ID -215 . Salt Lake City, Utah: US Department of Labor (USDOL), Occupational Safety and Health Administration (OSHA), Salt Lake Technical Center.
- [6] ISO [2005; reapproved 2010]. Method No. 16740 Workplace air - Determination of hexavalent chromium in airborne particulate matter - Method by ion chromatography and spectrophotometric measurement using diphenyl carbazide. Geneva, Switzerland: International Organization for Standardization (ISO).
- [7] Arar EJ, Pfaff JD, Martin TD [1994]. Method 218.6, Revision 3.3. Cincinnati, Ohio: Environmental Monitoring Systems Laboratory, Office of Research and Development, U.S. Environmental Protection Agency.
- [8] NIOSH [1975]. Criteria for a recommended standard: occupational exposure to chromium (VI). Cincinnati, OH: U.S. Department of Health, Education, and Welfare, Center for Disease Control, National Institute for Occupational Safety and Health, DHEW (NIOSH) Publication No. 76-129.
- [9] Wang J, Ashley K, Kennedy ER, Neumeister C [1997]. Determination of hexavalent chromium in industrial hygiene samples using ultrasonic extraction and flow injection analysis. *Analyst* 122:1307-1312.
- [10] Ndung'u K, Djane N-K, Malcus F, Mathiasson L [1999]. Ultrasonic extraction of hexavalent chromium in solid samples followed by automated analysis using a combination of supported liquid membrane extraction and uv detection in a flow system. *Analyst* 124:1367-1372.
- [11] Wang J, Ashley K, Marlow D, England EC, Carlton G [1999]. Field method for the determination of hexavalent chromium by ultrasonic and strong anion exchange solid phase extraction. *Anal Chem* 71:1027-1032.
- [12] EC/IRMM [1997]. Certificate of analysis, CR M545: Cr(VI) and total leacheable Cr in welding dust loaded on a filter. Brussels: Commission of the European Communities, Institute for Reference Materials and Measurements.
- [13] Burkart JA [1986]. General procedures for limit of detection calculations in industrial hygiene chemistry laboratory. *Appl Ind Hyg*, 1(3):153 -155.

METHOD REVISED BY:

Kevin Ashley, NIOSH

Penny A. Foote, James B. Perkins, Don C. Wickman, DataChem Laboratories, Inc, Salt Lake City, Utah

Disclaimer: Mention of any company or product does not constitute endorsement by NIOSH. In addition, citations to websites external to NIOSH do not constitute NIOSH endorsement of the sponsoring organizations or their programs or products. Furthermore, NIOSH is not responsible for the content of these websites. All web addresses referenced in this document were accessible as of the publication date.

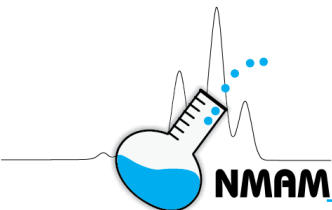

LEAD BY PORTABLE ULTRASONIC EXTRACTION/ASV

7701

Pb MW: 207.19 (Pb) CAS: 7439-92-1 (Pb) RTECS: OF7525000 (Pb)
 223.19 (PbO) 1317-36-8 (PbO) OG1750000 (PbO)

METHOD: 7701, Issue 3

EVALUATION: FULL

Issue 1: 15 January 1998

Issue 3: 17 February 2016

OSHA: 0.05 mg/m³
NIOSH: 0.05 mg/m³

PROPERTIES: soft gray metal; d 11.3 g/cm³ @ 20 °C; MP 327.5 °C, BP 1749 °C; valences 2+, 4+ in salts

SYNONYMS: elemental lead, lead compounds (except alkyl lead)

| SAMPLING | | MEASUREMENT | |
|--|--|---|---|
| SAMPLER: | FILTER (37-mm, 0.8- μ m pore, mixed cellulose ester membrane) | TECHNIQUE: | PORTABLE ANODIC STRIPPING VOLTAMMETRY |
| FLOW RATE: | 1 to 4 L/min | ANALYTE: | Lead |
| VOL-MIN: | 20 L @ 0.05 mg/m ³ | EXTRACTION: | 10% HNO ₃ 10 mL; ultrasonication |
| -MAX: | 1500 L | ANALYSIS | |
| SHIPMENT: | Routine | ALIQUOT VOL: | 0.1 to 5 mL |
| SAMPLE STABILITY: | Stable | DEPOSITION POTENTIAL: | -0.8 V to -1.0 V vs. Ag/AgCl |
| BLANKS: | Minimum of 2 field blanks per set | ANODIC SWEEP: | Deposition potential to 0.0 V vs. Ag/AgCl sweep rate variable [1,2] |
| ACCURACY | | REFERENCE ELECTRODE: | Ag/AgCl or calomel |
| RANGE STUDIED: | 0.025 to 0.150 mg/m ³ (as Pb) (based on Pb mass loadings) [4] | WORKING ELECTRODE: | Mercury film on glassy carbon or screen printed |
| BIAS: | None identified in laboratory studies [3-5] <10% in field study [6] | SUPPORTING ELECTROLYTE: | Mixture of NaCl/NaOH or KCl/KOH, L-ascorbic acid |
| OVERALL PRECISION ($\bar{S}_{r,T}$): | 0.087 (screen-printed electrodes); 0.094 (Hg film on glassy carbon electrodes) [4] | CALIBRATION: | Pb ²⁺ in 5% HNO ₃ |
| ACCURACY: | \pm 17.2% \pm 19.3% | RANGE: | 0.31 to >1000 μ g Pb per sample [3,4] |
| | | ESTIMATED LOD: | 0.05 μ g/sample [1] |
| | | PRECISION ($\bar{S}_{r,}$): | 0.068 @ 60 μ g (as Pb) per sample [3] |

APPLICABILITY: The working range is (at least) 0.20 to 5.00 mg/m³ (as Pb) for a 120-L air sample. Lead determination by ultrasonic extraction/ASV method is applicable to the on-site, field-based determination of lead in air filter samples, and also may be used for laboratory-based air filter sample preparation and analysis.

INTERFERENCES: Thallium is a known interference, but its presence is unlikely in the vast majority of samples. Extremely high concentrations of copper may cause a positive bias. Surfactants can poison electrode surfaces, so if the presence of surfactants is suspected they must be eliminated during sample preparation [7,8].

OTHER METHODS: Laboratory-based methods include atomic spectrometric methods following concentrated acid hotplate digestion: NIOSH methods 7082 (flame AAS), 7105 (graphite furnace AAS), and 7300-series methods (ICP-AES) [9]. ASTM standards based on NIOSH methods for sample collection, preparation and analysis have been published [10].

REAGENTS:

1. Nitric acid,* 10% (v/v) (Prepared from concentrated nitric acid, reagent grade; spectroscopic grade if trace analysis).
2. Distilled or deionized water (ASTM Type I or better [11]).
3. Calibration stock solution, 1000 µg/mL Pb. Commercial standard, or dissolve 1.00 g Pb metal in minimum of 10 mL of 50% HCl and dilute to 1 L with 1% (v/v) HCl. Store in a polyethylene bottle. Stable for at least one year.
4. Supporting electrolyte: Aqueous inert salt mixture such as 2.5 M NaCl and 0.25 M NaOH* (reagent grade or equivalent) [3,4].
5. Dissolved oxygen scavenger such as 0.25 M L-ascorbic acid (tissue culture grade or equivalent) [3,4].
6. Mercuric nitrate (reagent grade), if required (for Hg film electrodes).
7. Certified Reference Materials (CRMs) for lead.

*See SPECIAL PRECAUTIONS.

EQUIPMENT:

1. Sampler: Mixed cellulose ester filter, 0.8 µm pore size, 37-mm diameter, in cassette filter holder or cellulosic internal capsule.
2. Personal sampling pump, 1 to 4 L/min, with flexible connecting tubing.
3. Field-portable anodic stripping voltammeter.
4. Disposable or renewable voltammetry electrodes.
5. Ultrasonic bath, 50 watts minimum power.
6. Power source for ultrasonic bath.
7. Plastic centrifuge tubes, 50-mL, with screw caps.
8. Test tube rack (size to fit in ultrasonic bath).
9. Plastic sample cell container.
10. Mechanical pipets (class A equivalent), 0.1-mL to 10-mL, as needed.
11. Pipet tips for mechanical pipets.
12. Forceps.
13. Bottles, polyethylene, 100- to 1000-mL.
14. Volumetric flasks, 100-mL (for preparatory lab work).
15. Plastic rods.
16. Wipes (ASTM E1792 [12])

NOTE: Clean all glassware and reusable plasticware with diluted nitric acid and rinse thoroughly with distilled or deionized water before use.

SPECIAL PRECAUTIONS: Nitric acid and sodium hydroxide are irritants and may burn skin. Perform extractions in a well-ventilated area. Wear gloves and eye protection.

SAMPLING:

1. Calibrate each personal sampling pump with a representative sampler in the line.
2. Sample at an accurately known flow rate between 1 and 4 L/min for up to 8 h for a total sample size of 20 to 1500 L for TWA measurements. Do not exceed a filter loading of ca. 5 mg total dust.
NOTE: Filter overloading can be assessed by periodic visual checks. See NMAM guidance chapters for additional discussion on filter capacity.

SAMPLE PREPARATION:

3. Open the cassette filter holders and, with forceps, transfer the samples and blanks to separate 50-mL centrifuge tubes. Use internal cellulosic capsules or wipe the internal cassette surfaces with a 37 mm MCE filter or cellulosic wipe wetted with deionized water and add to the centrifuge tube to transfer non-filter aerosol deposits into the tube. See [13] for additional information. Push the filters to the bottom of the tubes with plastic rods.
NOTE: An alternative means to include non-filter aerosol deposits is to carry out extraction directly within the cassette.
4. Add 10 mL of 10% HNO₃ and cap the centrifuge tubes.

5. Place centrifuge tubes in ultrasonic bath, and agitate at room temperature for at least 30 min.
NOTE 1: The water level in the bath should be above the level of liquid within the centrifuge tubes.
NOTE 2: Proper performance of the ultrasonic bath should be demonstrated before use. This can be accomplished by checking recoveries of lead from performance evaluation materials.
6. Shake tubes for 5 to 10 sec, and allow to settle.

CALIBRATION AND QUALITY CONTROL:

7. Prior to field work, prepare a series of working standards covering the range 0.25 to 20 µg/mL Pb.
 - a. Add aliquots of calibration stock solution to 100-mL volumetric flasks, and dilute to volume with 10% HNO₃. Store and transport the working standards in polyethylene bottles, and prepare fresh weekly.
 - b. Analyze the working standards together with the blanks and samples (steps 11 through 14).
 - c. Prepare a calibration graph of instrumental response vs. lead concentration (µg/mL Pb).
NOTE: Some portable instruments read concentration directly. Calibrate according to manufacturer's directions.
8. Analyze at least one standard for every 20 samples to check for instrument drift (steps 11 through 14).
9. Check recoveries with at least one spiked media blank per 20 samples (one per batch minimum). Use certified reference materials to substantiate recoveries. Use method of standard additions to check for matrix effects or interferences.
10. Check for lead contamination by analyzing at least one reagent and one media blank per 20 samples (minimum of one per batch) (steps 11 through 14).

MEASUREMENT:

11. Set instrument parameters as specified by the manufacturer, or use conditions specified on page 7701-1.
NOTE: If renewable electrodes are used, clean the glassy carbon electrode and deposit a fresh mercury film prior to conducting analyses.
12. Transfer sample aliquot (1 to 5 mL) to analytical cell, and dilute with 10% HNO₃, if necessary.
NOTE: High concentrations of lead may require analysis of diluted analyte solutions.
13. Add supporting electrolyte and oxygen scavenger to sample cell. Ensure final volume of the cell is 5 mL (disposable electrodes) or 10 mL (renewable electrodes) by diluting with distilled or deionized water.
14. Measure lead content of the sample aliquot (µg/sample or µg/mL), and record the result.
NOTE 1: For renewable electrodes, rinse and drain electrochemical sample cell at least three times with distilled or deionized water between sample runs. For disposable electrodes, use a fresh plastic sample cell container for each sample analyzed.
NOTE 2: If the measured value is above the linear range of the standards, dilute with 10% HNO₃, reanalyze, and apply the appropriate dilution factor in the calculations.

CALCULATIONS:

15. Using measured lead contents, calculate the corresponding concentrations (µg/mL) of lead in the original extracted sample, C_s , and average media blank, C_b , from the calibration graph.
NOTE: Be sure to account for dilution factors.
16. Using solution volumes (mL) of the samples, V_s , and media blanks, V_b , calculate the concentration, C (mg/m³), of lead in the air volume sampled, V (L):

$$C = \frac{C_s V_s - C_b V_b}{V}, \text{ mg/m}^3$$

NOTE: µg/L \cong mg/m³

EVALUATION OF METHOD:

This method was evaluated with lead aerosol samples generated in the laboratory (40 to 80 µg Pb per filter) [3], and with air particulate samples collected from workplaces where abrasive blasting of leaded paint on highway bridges was being conducted [4]. For the latter, lead loadings cover the range from below the detection limit of 0.09 µg Pb per filter to loadings in excess of 1500 µg Pb per filter [4]. The method also has been evaluated with performance evaluation materials and by interlaboratory testing [3-5]. Lead recoveries from Certified Reference Materials (CRMs) were found to be quantitative (≥90%) and equivalent to recoveries obtained using confirmatory analytical methods (NIOSH 7082, 7105, and 7300 [9]).

REFERENCES:

- [1] Wang J [1985]. Stripping analysis. New York: VCH Publishers.
- [2] Wang J [1996]. Electrochemical preconcentration. In: Kissinger PT, Heineman WR, eds. Laboratory techniques in electroanalytical chemistry. 2nd ed. New York: Marcel Dekker, pp. 719-737.
- [3] Ashley K [1995]. Ultrasonic extraction and field-portable anodic stripping voltammetry of lead from environmental samples. *Electroanalysis* 7:1189-1192.
- [4] Ashley K, Mapp KJ, Millson M [1998]. Ultrasonic extraction and field-portable anodic stripping voltammetry for the determination of lead in workplace air samples. *Am Ind Hyg Assoc J* 59:671-679.
- [5] Ashley K, Song R, Esche CA, Schlecht PC, Baron PC, Wise TJ [1999]. Ultrasonic extraction and portable anodic stripping voltammetric measurement of lead in paint, dust wipes, soil, and air: An interlaboratory evaluation. *J Environ Monit* 1:459-464.
- [6] Sussell A, Ashley K [2002]. Field measurement of lead in workplace air and paint chip samples by ultrasonic extraction and portable anodic stripping. *J Environ Monit* 4:156-161.
- [7] Ashley K [1994]. Electroanalytical applications in occupational and environmental health. *Electroanalysis* 6:805-820.
- [8] Ashley K, Wise TJ, Mercado W, Parry DB [2001]. Ultrasonic extraction and portable anodic stripping voltammetric measurement of lead in dust wipe samples. *J Hazard Mater* 83:41-50.
- [9] NIOSH [1994]. Lead: Method 7082, Lead by GFAAS: Method 7105, Elements: Method 7300. In: Eller PM, Cassinelli ME, eds. NIOSH manual of analytical methods. 4th ed. Cincinnati, OH: U.S. Department of Health and Human Services, Centers for Disease Control and Prevention, National Institute for Occupational Safety and Health, DHHS (NIOSH) Publication No. 94-113 [www.cdc.gov/niosh/nmam/].
- [10] ASTM [2003]. Standard Nos. E1613, E1741, E1775, E1979, E2051. In: Annual Book of ASTM Standards, Vol. 04.11. W. Conshohocken, PA: ASTM International.
- [11] ASTM [2003]. Standard No. D1193: Specification for reagent water. In: Annual Book of ASTM Standards, Vol. 11.01. W. Conshohocken, PA: ASTM International.
- [12] ASTM [2011]. Standard No. E1792: Standard specification for wipe sampling materials for lead in surface dust. In: Annual Book of ASTM Standards, Vol. 04.11. W. Conshohocken, PA: ASTM International.
- [13] Ashley K, Harper M [2013]. Closed-face filter cassette (CFC) sampling-guidance on procedures for inclusion of material adhering to internal sampler surfaces. *J Occup Environ Hyg* 10:D29-D33.

METHOD REVISED BY:

Kevin Ashley, Ph.D., NIOSH.

Disclaimer: Mention of any company or product does not constitute endorsement by NIOSH. In addition, citations to websites external to NIOSH do not constitute NIOSH endorsement of the sponsoring organizations or their programs or products. Furthermore, NIOSH is not responsible for the content of these websites. All web addresses referenced in this document were accessible as of the publication date.

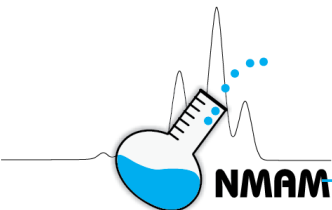

CHROMIUM, HEXAVALENT, by Field-Portable Spectrophotometry

7703

Cr(VI) AW: 52.00 CAS: 18540-29-9 RTECS: GB6262000
 CrO₃ MW: 99.99 CAS: 1333-82-0 RTECS: GB6650000

METHOD: 7703, Issue 2

EVALUATION: FULL

Issue 1: 15 March 2003

Issue 2: 20 October 2015

OSHA: 0.005 mg/m³ (1910.1026); C 0.1 mg/m³ as CrO₃
 (exceptions to 1910.1026)

PROPERTIES: Oxidizing agent

NIOSH: 0.0002 mg/m³ (8 h); carcinogen

SYNONYMS: Vary depending on the compound; chromate commonly used

| SAMPLING | MEASUREMENT |
|---|---|
| <p>SAMPLER: FILTER (5.0 µm PVC membrane [1,2]; 0.8 µm MCE or 1.0 µm PTFE acceptable for field analysis [3])</p> <p>FLOW RATE: 1 L/min to 4 L/min</p> <p>VOL-MIN: 54 L (2 L/min for 27 min) -MAX: 1200 L (3 L/min for 400 min)</p> <p>SHIPMENT: Refrigerant pack at 4 °C ± 2 °C (optional)</p> <p>SAMPLE STABILITY: Analyze within 24 h; if applicable, keep samples at 4 °C ± 2 °C</p> <p>BLANKS: One per twenty field samples, minimum of 2 per set</p> | <p>TECHNIQUE: FIELD-PORTABLE VISIBLE SPECTROPHOTOMETRY</p> <p>ANALYTE: Chromium-diphenylcarbazone complex</p> <p>EXTRACTION: 10 mL 0.05 mol/L ammonium sulfate / 0.05 mol/L ammonium hydroxide (pH = 8 ± 0.5), ultrasonic extraction 30 min</p> <p>Cr(VI) ISOLATION: Strong anion exchange solid phase extraction</p> <p>ELUTION SOLUTION: 0.5 mol/L ammonium sulfate / 0.1 mol/L ammonium hydroxide</p> <p>WAVELENGTH: 540 nm, 1 cm path length</p> <p>CALIBRATION: Standard solutions of potassium chromate in elution solution</p> <p>RANGE: 1 µg to 400 µg per sample</p> <p>ESTIMATED LOD: 0.08 µg hexavalent chromium per sample [3]</p> <p>PRECISION (\bar{S}_r): 0.035 @ 3 µg to 400 µg per sample [3]</p> |
| ACCURACY | |
| <p>RANGE STUDIED: 0.045 µg/m³ to 1146 µg/m³ (about 20 L to 200 L samples) [3,4]</p> <p>BIAS: -1.00% [3]</p> <p>OVERALL PRECISION (\hat{S}_{rr}): 0.080</p> <p>ACCURACY: ±15.7%</p> | |

APPLICABILITY: The working range is 0.22 µg/m³ to 333 µg/m³ for a 1200 L air sample. This method may be used for the determination of soluble forms of hexavalent chromium. Insoluble hexavalent chromium requires modification of the method using ultrasonic extraction with carbonate buffer.

INTERFERENCES: Interferences from reducing agents such as divalent iron are minimized to the extent possible by the alkaline ultrasonic and solid phase extraction procedures. Interferences from other metal cations are eliminated by solid phase extraction [5]. Some reduction can occur on the filter during sampling, and is usually due to the presence of divalent iron, organic material, and/or acidic conditions [6]. Reduction of hexavalent chromium can occur over time on any filter type, and is especially problematic on MCE filters [7]. However, the use of MCE and PTFE filters has been found to be acceptable for field use, where performance has been found to be equivalent to that of PVC filters [3]. During ultrasonic extraction, oxidation of trivalent chromium in solution to hexavalent chromium is prevented by the use of an ammonium buffer [8].

OTHER METHODS: This method is designed to be used in the field, but can also be utilized in the fixed-site laboratory. It is an alternative to laboratory methods such as NIOSH method 7605 or OSHA method ID-215 (hot plate digestion and ion chromatography). NIOSH method 7600 is a similar procedure, but no separation step is used. A field method not involving hexavalent chromium isolation, MDHS method 61, has been promulgated by the British Health and Safety Executive [9].

REAGENTS:

1. Ammonium sulfate, reagent grade.
2. Ammonium hydroxide,* reagent grade.
3. Water, distilled or deionized.
4. Hydrochloric acid (37% mass fraction),* reagent grade.
5. Acetonitrile,* reagent grade.
6. 1,5-Diphenylcarbazide (DPC), reagent grade.
7. Methanol,* reagent grade.
8. Extraction solution (extraction buffer): 0.05 mol/L ammonium sulfate / 0.05 mol/L ammonium hydroxide, 1 L, aqueous in distilled or deionized water.
NOTE: Modification of method by using carbonate buffer (e.g., sodium carbonate) is required for extraction of insoluble hexavalent chromium.
9. Elution solution (elution buffer): 0.5 mol/L ammonium sulfate / 0.1 mol/L ammonium hydroxide, 250 mL, in distilled or deionized water.
10. Potassium chromate,* reagent grade.
11. Hexavalent chromium standard,* 1000 µg/mL. Dissolve 3.735 g potassium chromate in deionized water to make 1 L, or use commercially available solution.
12. Calibration stock solution,* 100 µg/mL: dilute 1000 µg/mL hexavalent chromium standard 1:10 with extraction buffer. (Solution is stable for a month.)
13. Diphenylcarbazide complexation solution (20 mmol/L): Measure 0.48 g DPC powder and place in a 100 mL volumetric flask. Add about 80 mL of acetonitrile and dissolve the DPC. Bring up to the mark with additional acetonitrile and mix thoroughly.

*See SPECIAL PRECAUTIONS.

EQUIPMENT:

1. Samplers: 5 µm pore size polyvinylchloride (PVC), 0.8 µm pore size mixed cellulose ester (MCE), or 1.0 µm polytetrafluoroethylene (PTFE) filters, 37 mm diameter, with backup pads, in polystyrene cassette filter holder, 2- or 3-piece.
NOTE: MCE filters, and some PVC filters, promote reduction of hexavalent chromium on a timescale of a few days. However, either filter type is acceptable for field use if the samples are to be analyzed within 24 h of collection.
2. Personal sampling pump, 1 L/min to 4 L/min, with flexible connecting tubing.
3. Ultrasonic bath (sonicator), 100 W minimum power.
4. Solid phase extraction manifold, multi-port.
5. Portable vacuum pump with pressure metering valve.
6. Portable visible spectrophotometer, sample path length 1 cm with quartz cuvette(s).
7. Strong anion exchange solid phase extraction (SPE) cartridges, 10 mL, disposable; loaded with 500 mg or 1000 mg quaternary amine bonded silica, capacity about 1 mmol/g of singly charged anion.
8. Pipettors, mechanical, assorted volumes (e.g., 1 mL to 10 mL) with disposable tips.
9. Micropipettors, mechanical, assorted volumes (e.g., 10 µL to 100 µL) with disposable tips.
10. Centrifuge tubes, plastic, 15 mL, with screw caps.
11. Scintillation vials, 20 mL, glass, with PTFE-lined screw caps.
12. Assorted beakers (and possibly Erlenmeyer flasks), various volumes.
13. Volumetric flasks, 25 mL, 100 mL, 250 mL, and 1000 mL.
14. Forceps, PTFE-coated.
15. Glass or plastic rods.
16. Disposable gloves, plastic or latex.
17. Laboratory wipes.
18. Portable power generator (if necessary).
NOTE: If no power supply is available at the field site, electric power can be provided by means of a portable, gasoline (or other) generator.

SPECIAL PRECAUTIONS: NIOSH considers all hexavalent chromium compounds to be suspect occupational carcinogens [10]. Efforts must be made to prevent aerosolizing chromate-containing

compounds and solutions. All sample preparation should be carried out in a well-ventilated area (vacuum hood preferable); forced ventilation should be used if no hood is available. Methanol and acetonitrile solutions are flammable and must be handled carefully, i.e., wearing of impermeable gloves and avoidance of vapors. To the extent possible, solutions should be prepared in the laboratory before taking them to the field. Concentrated hydrochloric acid is highly corrosive and ammonium hydroxide is a respiratory irritant. All work with these compounds should be performed in a hood. Use proper protective clothing including gloves, safety glasses, and laboratory coat. Potassium chromate is a strong oxidizer with risk of fire and explosion upon contact with combustible substances and reducing agents.

SAMPLING:

1. Calibrate each personal sampling pump with a representative sampler in line.
2. Sample at an accurately known flow rate in the range of 1 L/min to 4 L/min for a sample size of 54 L to 1200 L. Do not exceed 2 mg of particulate loading on the filter. Label the filter cassette.
3. Don a fresh pair of disposable plastic or latex gloves (to prevent sample contamination).
4. With PTFE-coated forceps, remove filters from cassettes after completion of sampling, and place in separate plastic 15 mL centrifuge tubes for subsequent sample preparation. Discard cellulose backup pads and gloves.

SAMPLE PREPARATION:

5. Add 10 mL of extraction solution (weak buffer) to each 15 mL centrifuge tube containing the filter sample. Ensure that the filter is covered by the extraction solution. If necessary, push the filter down with a clean glass or plastic rod to immerse the entire filter. Cap and label the tubes.
6. Place sample tubes in the ultrasonic bath (sonicator). The water level in the bath should be higher than the liquid level in the centrifuge tube. Sonicate for 30 min.

NOTE: Numerous centrifuge tubes containing sample filters can be subjected to sonication at one time, depending upon the size of the ultrasonic bath. Ensure that the bath is warm (but < 40 °C).

7. Set up the solid phase extraction manifold.
 - a. Place disposable solid phase extraction (SPE) cartridges in each port, and place scintillation vials beneath the cartridges. Label the cartridges.
 - b. Attach the vacuum pump to the SPE manifold.
 - c. To condition SPE cartridges, pipet 3 mL of methanol into each cartridge, and evacuate. Then pipet 3 mL of extraction solution into each cartridge, and evacuate. Repeat.
8. Extract hexavalent chromium from sample solution.
 - a. Pipet 3 mL to 5 mL of each ultrasonicated sample solution from the centrifuge tubes into the disposable SPE cartridge. Dispose of the pipet tip.
 - b. Adjust the vacuum to obtain an extraction rate of about one drop per second (approximately 27 kPa or 203 mmHg; no more than 34 kPa or 254 mmHg). Manually tighten cartridges by twisting, if necessary, to slow down the rate of liquid dripping.

NOTE 1: For samples in which the expected hexavalent chromium concentration is high, smaller aliquots (1 mL to 2 mL) should be dispensed into the SPE cartridges to prevent breakthrough. High concentration of hexavalent chromium can be assessed visually by its orange color.

NOTE 2: For samples having low hexavalent chromium concentration, additional 3 mL to 5 mL aliquots of ultrasonicated sample solution can be loaded onto SPE cartridges (step 8.a). In this manner, the cartridge can be used to preconcentrate hexavalent chromium.

- c. When it appears the solution has passed through all the cartridges, increase the vacuum to ensure that all solution passes through the cartridges. This step selectively binds hexavalent chromium to the stationary phase of each cartridge.

- d. To remove residue of trivalent chromium and other potential interferences, reduce the vacuum to 0. Add 1 mL distilled or deionized water to each cartridge, adjust vacuum to obtain 1 drop per second (about 27 kPa or 203 mmHg), then reduce vacuum to 0 when completed.
 - e. Remove the scintillation vials beneath the cartridges and discard.
NOTE: This solution contains unwanted fractions that should contain no hexavalent chromium.
9. Place clean, labeled scintillation vials beneath correct cartridges in the SPE manifold.
- a. Add 9 mL of the elution solution (elution buffer) to each cartridge to elute hexavalent chromium, and repeat steps 8.b, 8.c, and 8.d.
 - b. Remove the scintillation vials, and cap them. Dispose of the used SPE cartridges.
NOTE: The scintillation vials now contain extracted and isolated hexavalent chromium, which is ready for subsequent analysis.
10. Uncap each scintillation vial containing extracted and isolated hexavalent chromium, and add 100 μ L hydrochloric acid.
11. Add 2 mL DPC complexation solution, recap vials, and mix thoroughly. Allow to stand for at least 5 min for complete color development.

CALIBRATION AND QUALITY CONTROL:

12. Calibrate daily with at least 6 working standards over the range of 0 μ g/mL to 2 μ g/mL of hexavalent chromium per standard.
- a. To 10 mL volumetric flasks containing about 5 mL of elution solution (strong buffer), pipet known volumes (10 μ L to 200 μ L) of hexavalent chromium calibration stock solution (100 μ g/mL) to produce concentrations of 0.1 μ g/mL, 0.2 μ g/mL, 0.5 μ g/mL, 1.0 μ g/mL, and 2.0 μ g/mL. Add 100 μ L of hydrochloric acid and 2 mL of DPC complexation solution to each. Dilute to the mark with elution solution and mix thoroughly.
NOTE: A minimum of two of the concentration levels (e.g., 0.1 μ g/mL and 1.0 μ g/mL) should be run at least in triplicate.
 - b. Prepare a blank by pipetting 100 μ L of hydrochloric acid and 2 mL of DPC complexation solution into 10 mL volumetric flask containing about 5 mL of the elution solution (elution buffer); dilute to the mark with elution solution and mix thoroughly.
 - c. Analyze the calibration solutions and the blank (steps 15, 16, 17, 18, 19, and 20).
13. Analyze at least two field blanks, one field blank per twenty samples (steps 10, 11, 15, 16, 17, 18, 19, and 20). Also analyze at least three of the calibration solutions in triplicate.
14. Prepare a calibration graph of absorbance vs. hexavalent chromium concentration.
NOTE: As an alternative to steps 12, 13, and 14, the standard addition approach can be used [11].

MEASUREMENT:

15. Turn on the spectrophotometer, and allow for an appropriate warm-up period.
16. Set the spectrophotometer to 540 nm. Set portable spectrophotometer parameters according to the manufacturer's instructions and the conditions on page 7703-1.
17. Rinse the quartz cuvette three times with distilled or deionized water, then rinse with blank solution.
18. Measure the blank. Adjust the spectrometer to zero absorbance.
19. Uncap the scintillation vial containing the sample solution to be analyzed.
- a. Condition the cuvette by filling with the solution to be analyzed, and discard the solution.
 - b. Refill the cuvette with the sample solution to be analyzed.
 - c. Place the cuvette in the spectrophotometer.
NOTE: Wipe any extra moisture or liquid off the sides of the cuvette with a dry laboratory wipe, and take care to handle the cuvette only by the frosted sides.
20. Analyze samples, standards, and blanks. Record the absorbance.
NOTE: If the absorbance value is greater than 2 absorbance units, dilute the solution to be analyzed with elution solution (strong buffer) and reanalyze.

CALCULATIONS:

21. From the calibration graph, determine the mass of hexavalent chromium in each sample, W (μg), and in the average field blank, B (μg).

NOTE: If standard addition method was used, make appropriate adjustments from the calibration graph obtained [11].

22. Calculate the concentration, C , of hexavalent chromium in the air volume sampled, V (L):

$$C = \frac{(W - B)}{V}, \mu\text{g/L or mg/m}^3.$$

NOTE 1: If samples were diluted during sample preparation, be sure to account for the dilution factor in the calculation.

NOTE 2: If the hexavalent chromium concentration is to be reported as chromic acid (CrO_3), multiply C by 1.92 (MW of chromic acid divided by AW of chromium).

EVALUATION OF METHOD:

This method was evaluated in the laboratory with spiked filters [3,4,5] and a certified reference material containing a known loading of hexavalent chromium [4]. This certified reference material (CRM) is European Commission, Institute for Reference Materials and Measurements (EC/IRMM) CRM 545, hexavalent chromium and total chromium in welding dust loaded on a glass fiber filter [12]. The method has also been evaluated in the field, where samples collected during aircraft maintenance operations were analyzed on-site [3,4]. The accuracy was estimated using the protocol summarized in a NIOSH technical report [13].

Alternative filter types can also be used, e.g., PTFE, binder-free glass fiber filters, or quartz fiber filters. Filter materials should be tested before use to ensure hexavalent chromium stability. Filters can be pretreated with base to minimize hexavalent chromium reduction during sampling in high-iron or acidic environments [6].

REFERENCES:

- [1] NIOSH [1994]. Chromium, hexavalent: Method 7600. In: Eller PM, Cassinelli ME, eds. NIOSH manual of analytical methods. 4th ed. Cincinnati, OH: U.S. Department of Health and Human Services, Centers for Disease Control and Prevention, National Institute for Occupational Safety and Health, DHHS (NIOSH) Publication No. 94-113 [www.cdc.gov/niosh/nmam/].
- [2] ASTM [2013]. Standard test method for the determination of hexavalent chromium in workplace air by ion chromatography and spectrophotometric measurement using 1,5-diphenylcarbazide: method D6832-13. West Conshohocken, PA: ASTM International. DOI: 10.1520/D6832-13.
- [3] Marlow D, Wang J, Wise TJ, Ashley K [2000]. Field test of a portable method for the determination of hexavalent chromium in workplace air. *Am Lab* 32(15):26–28.
- [4] Wang J, Ashley K, Marlow D, England EC, Carlton G [1999]. Field method for the determination of hexavalent chromium by ultrasonication and strong anion-exchange solid-phase extraction. *Anal Chem* 71(5):1027–1032.
- [5] Wang J, Ashley K, Kennedy ER, Neumeister C [1997]. Determination of hexavalent chromium in industrial hygiene samples using ultrasonic extraction and flow injection analysis. *Analyst* 122(11):1307–1312.
- [6] Foster RD, Howe AM, Cottrell SJ, Northage C [1996]. An investigation of the exposure of workers to hexavalent chromium in the air of plating works. Sheffield, UK: Health and Safety Executive, Health and Safety Laboratory, HSL Report IR/L/95/15.
- [7] Molina D, Abell MT [1987]. An ion chromatographic method for insoluble chromates in paint aerosol. *Am Ind Hyg Assoc J* 48(10):830–835.

- [8] Ndung'u K, Djane N-K, Malcus F, Mathiasson L [1999]. Ultrasonic extraction of hexavalent chromium in solid samples followed by automated analysis using a combination of supported liquid membrane extraction and UV detection in a flow system. *Analyst* 124(9):1367–1372.
- [9] Health and Safety Executive [1988]. Total hexavalent chromium compounds in air—colorimetric laboratory method using 1,5-diphenylcarbazide: MDHS 61. In: *Methods for the determination of hazardous substances*. London: Health and Safety Executive.
- [10] NIOSH [2013]. Criteria for a recommended standard: occupational exposure to hexavalent chromium. Cincinnati, OH: U.S. Department of Health and Human Services, Centers for Disease Control and Prevention, National Institute for Occupational Safety and Health, DHHS (NIOSH) Publication No. 2013-128 [www.cdc.gov/niosh/docs/2013-128/].
- [11] Skoog DA, West DM, Holler FJ [1988]. *Fundamentals of analytical chemistry*. New York: W.B. Saunders.
- [12] EC/IRMM [1997]. Certificate of analysis, CRM 545: Cr(VI) and total leachable Cr in welding dust loaded on a filter. Brussels: Commission of the European Communities, Institute for Reference Materials and Measurements.
- [13] NIOSH [1995]. Guidelines for air sampling and analytical method development and evaluation. By Kennedy ER, Fischbach TJ, Song R, Eller PM, Shulman SA. Cincinnati, OH: U.S. Department of Health and Human Services, Centers for Disease Control and Prevention, National Institute for Occupational Safety and Health, DHHS (NIOSH) Publication No. 95-117 [www.cdc.gov/niosh/docs/95-117/pdfs/95-117.pdf].

METHOD WRITTEN BY:

Kevin Ashley, Ph.D., NIOSH/DART; Jin Wang, Ph.D., NIOSH/HELD; David Marlow, NIOSH/DART; James Boiano, CIH, NIOSH/DSHEFS.

DISCLAIMER: Mention of any company or product does not constitute endorsement by NIOSH. In addition, citations to websites external to NIOSH do not constitute NIOSH endorsement of the sponsoring organizations or their programs or products. Furthermore, NIOSH is not responsible for the content of these websites. All web addresses referenced in this document were accessible as of the publication date.



BERYLLIUM in Air by Fluorometry

7704

Be

MW: 9.0121

CAS: 7440-41-7

RTECS: DS1750000

METHOD: 7704, Issue2

EVALUATION: FULL

Issue 1: 6 April 2007

Issue 2: 12 December 2015

OSHA: 2 µg/m³, ceiling 5 µg/m³, peak 25 µg/m³

MSHA: 2 µg/m³

DOE: 2 µg/m³ (action level 0.2 µg/m³)

NIOSH REL: 0.5 µg/m³

OTHER OELs: see Table 5

PROPERTIES: solid, d 1.85 g/mL, MP 1,278 °C, VP 0 kPa (0 mm Hg) @ 25 °C

SYNONYMS: beryllium metal, beryllia (BeO)

| SAMPLING | | MEASUREMENT | |
|---|---|--|--|
| SAMPLER: | FILTER (mixed cellulose ester or nylon membrane, 0.8 µm pore size, 25- or 37-mm diameter) | TECHNIQUE: | UV/VIS FLUOROMETRY |
| FLOW RATE: | (1 to 4) L/min | ANALYTE: | complex of hydroxybenzoquinoline sulfonate (HBQS) with beryllium |
| VOL-MIN: | 240 L | DISSOLUTION: | ammonium bifluoride (aqueous), 10 g/L |
| -MAX: | 2,000 L | DETECTION SOLUTION: | contains 63.4 µmol/L HBQS, 2.5 mmol/L EDTA, and 50.8 mmol/L lysine monohydrochloride (optional); pH adjusted to 12.85 with 10 mol/L NaOH, as necessary |
| SHIPMENT: | routine | DETECTOR: | excitation, 360 nm to 390 nm; emission, integrated between 470 and 480 nm ($\lambda_{max} \approx 475$ nm) |
| SAMPLE STABILITY: | stable | CALIBRATION: | beryllium standard solutions |
| BLANKS: | 3 field blanks min. | RANGE: | (0.005 to 6) µg per filter [1] |
| ACCURACY | | ESTIMATED LOD: | 0.0001 µg per filter [Table 4] |
| RANGE STUDIED: | 0.0001 to 6 µg per filter [1,2] | PRECISION (\bar{S}_r): | 0.021 at ≈ 0.2 µg per filter, 0.076 at ≈ 1.5 µg per filter, 0.052 at ≈ 3 µg per filter |
| BIAS: | negligible [1,2] | | |
| OVERALL PRECISION (\hat{S}_{rT}): | 0.094 | | |
| ACCURACY: | 18.9% | | |

APPLICABILITY: The working range of the method is 0.0005 µg/m³ to 0.6 µg/m³ for an air sample of 1,000 L. The analysis is for total beryllium and is not compound specific.

INTERFERENCES: Minor interference from iron can result if iron concentrations are high. Samples high in iron demonstrate a yellow or gold coloration. This interference can be minimized by allowing the solution to sit for at least two hours, during which time the solution clears, and then filtering the sample extract before use. An alternative method is to filter the solution after 30 minutes of standing through a hydrophilic filter of pore size of 0.2 µm or smaller.

OTHER METHODS: Method 7300 (hot plate digestion and inductively coupled plasma atomic emission spectrometry) is an alternative procedure for the determination of elemental beryllium [3], but with higher detection limits. ASTM method D7202 is a similar procedure to detect elemental beryllium by fluorescence [4].

REAGENTS:

1. Ammonium bifluoride.*
2. Ethylenediaminetetraacetic acid (EDTA), disodium salt, dihydrate.
3. 10-Hydroxybenzo[h]quinoline-7-sulfonate (HBQS) [5].
4. L-Lysine monohydrochloride.
5. Sodium hydroxide.*
6. Water, deionized.
7. Dissolution solution:* aqueous ammonium bifluoride, 10 g/L (prepared by dissolving ammonium bifluoride in deionized water).
8. Detection solution:* 63.4 $\mu\text{mol/L}$ HBQS, 2.5 mmol/L EDTA, and 50.8 mmol/L lysine monohydrochloride; pH adjusted to 12.85 with 10 mol/L NaOH). An alternative preparation of dye solution without lysine (lysine-free) may be made by adding 1.104 g of EDTA and 64 μmoles of the 10-HBQS dye in 900 ml of water. After a clear solution is obtained, 114.5 ml of 2.5 N NaOH is added and mixed to obtain the final dye solution. The pH of the dye solution is 13.2. The lysine-free dye solution (commercially available) may be used for all analytical purposes and also provides superior detection limits.
9. Beryllium standard solution,* 1,000 mg/L (commercially available).
10. Beryllium-spiked media* (commercially available).

*See SPECIAL PRECAUTIONS.

EQUIPMENT:

1. Sampler: membrane filter, mixed cellulose ester (MCE) or nylon, 0.8 μm pore size, 25- or 37-mm diameter.
2. Personal sampling pump, 1 L/min to 4 L/min, with clamps and flexible connecting tubing.
3. Ultraviolet/visible (UV/Vis) fluorometer, with excitation lamp ($\lambda = 380 \text{ nm}$) and time-integrating visible detector (400 nm to 700 nm, $\lambda_{\text{max}} \approx 475 \text{ nm}$) or optical filters for appropriate wavelengths (excitation of 360 nm to 390 nm; emission of $\approx 475 \text{ nm}$, with full width at half maximum of $\pm 5 \text{ nm}$).
4. Mechanical agitator, shaker, or rotator.
5. Hot block (for beryllium oxide extraction).
6. Fluorescence cuvettes, disposable, 10 mm diameter, transparent to UV/Vis radiation.
7. Centrifuge tubes, plastic, 15 mL.
8. Syringe filters, hydrophilic polypropylene, 0.2 μm pore size, 25-mm diameter, in plastic housings.
NOTE: Polytetrafluoroethylene (PTFE) filters are unsuitable for this method.
9. Pipettors, mechanical, of assorted sizes.
10. Pipet tips, plastic, disposable, of assorted sizes.
11. Labware, plastic (e.g., beakers, flasks, graduated cylinders), of assorted sizes.
12. Tweezers, plastic or plastic-coated.
13. Laboratory wipes.
14. Personal protective wear (e.g., respirators, gloves, lab coats, safety eyewear), as needed.

SPECIAL PRECAUTIONS: Wear appropriate personal protection during sampling activities and analysis. It is essential that suitable gloves, eye protection, laboratory coat, etc., be used when working with the chemicals. Perform sample preparation and analysis in a clean, well-ventilated area that is well removed from any possible beryllium contamination. Any area of skin affected by the dissolution or detection solutions must be immediately washed with plenty of water. Ammonium bifluoride will etch glass, so it is essential that all ammonium bifluoride solutions be contained in plastic labware. Avoid exposure by contact with skin or eyes, or by inhalation of vapor.

SAMPLING:

1. Calibrate each personal sampling pump with a representative sampler in line.
2. Sample at an accurately known flow rate between 1 L/min and 4 L/min for a total sample size of 240 L to 2,000 L for TWA measurements. Do not exceed a filter loading of $\approx 2 \text{ mg}$ total dust.
3. After sampling, remove the filters from the cassettes using clean tweezers, and place into labeled 15 mL plastic centrifuge tubes.

SAMPLE PREPARATION:

4. Add 5 mL of the dissolution solution (ammonium bifluoride, 10 g/L) to each 15 mL centrifuge tube containing an air filter sample, and cap each tube.
5. Place each tube into a mechanical rotator, and rotate for at least 30 min.

NOTE: Rotator may also be substituted by a shaker or an agitator as long as the dissolution solution wets the filter well. Sonication has also been shown to be effective. For dissolution of refractory materials such as high-fired beryllium oxide, agitation of the dissolution solution with the media must be replaced by heating to 85 °C for 60 minutes or more. Any standard dissolution process is particle-size dependent [6]. The two sources of BeO used to validate the method are described in the backup data report [7].

6. Filter each solution with a hydrophilic polypropylene syringe filter into a clean tube.

NOTE: This tube should be able to accept a cap so that the solution may be saved and used later for reanalysis if required.

7. Pipet 0.1 mL of each sample filtrate into cuvettes containing 1.9 mL of the detection solution. Cap and mix briefly.

NOTE: The above procedure is typically used to analyze a range of 0.05 µg to 6 µg of beryllium on the sampling media. Alternative ratios of dissolution solution and detection solution may be used for analyzing alternative ranges of beryllium concentration. To test a range of 0.005 µg to 0.4 µg of beryllium on the sampling media, 0.4 mL of the sample filtrate is added to 1.6 mL of the detection solution in the cuvettes. The lysine-free dye solution may also be used for obtaining even lower detection limits at a dilution ratio of 3×, where 1.33 ml of the dye solution is mixed with 0.67 ml of the filtered solution extracts (Table 3) and beryllium in the range of 0.0005 µg to 0.4 µg may be determined.

NOTE: If high iron or titanium concentration is suspected or is evident (owing to the appearance of suspended precipitate), allow the solution to settle and filter the solution using a hygroscopic syringe filter (e.g., polyethersulfone, or hydrophilic polypropylene).

NOTE: The stability of the detection and the dissolution solution is more than six months and of the mixed measurement solution comprising both is greater than 30 days. The solutions must be kept in sealed containers, and the detection and mixed solutions must be stored away from light.

NOTE: If the samples are suspected of having a contaminant that fluoresces and has excitation and emission spectra that overlap with that of the signal produced by the fluorescent dye bound to beryllium, then this contaminant needs to be removed. The presence of such a contaminant can be verified by subjecting the filtered sample to fluorescence excitation after the extraction step (without adding the fluorescent dye). If a fluorescence signal is detected, then that signal is ascribed to the presence of a fluorescent contaminant. To remove the contaminant, high-purity activated charcoal is added to the beryllium extraction solution (~10 mg/ml) and the extraction procedure is carried out at elevated temperature (80 to 90 °C for at least 45 minutes). If the beryllium extraction procedure has already been performed, then after the addition of activated charcoal, the extraction process is repeated at the elevated temperature. The solution is filtered to remove the activated charcoal before adding this to the detection solution to make the measurement solution. Details of this process have been published [8].

CALIBRATION AND QUALITY CONTROL:

8. Calibrate the fluorometer with beryllium stock standard solutions. Prepare a calibration graph of fluorescence intensity vs. beryllium concentration (ng/mL) in the stock standard.

NOTE: To test a range of 0.05 µg to 6 µg of beryllium on the sampling media, beryllium stock standard solutions are made up using beryllium spectrometric standards diluted with the ammonium bifluoride dissolution solution. A recommended series of stock standard solutions is (800, 200, 40, 10, and 0) ng/mL. As with the samples, the stock standards are prepared for analysis by adding 0.1 mL of beryllium stock standard into 1.9 mL of detection solution (20-fold dilution). Please see Table 1. Either of the two detection solutions may be used.

NOTE: To test a range of 0.005 µg to 0.4 µg of beryllium on the sampling media, a recommended series of stock standard solutions is (80, 20, 4, 1, and 0) ng/mL. These standards with lower beryllium concentration can be prepared by 10-fold dilution of the stock standards mentioned in the note above. As with the samples, these stock standards are prepared for analysis by adding 0.4 mL of beryllium stock standard into 1.6 mL of detection solution (5-fold dilution). Please see Table 2. Either of the two detection solutions may be used.

NOTE: When using the lysine-free dye solution ONLY, To test a range can be tested of 0.0005 to 0.4 µg of beryllium on the media using a recommended series of stock solutions is (0, 0.15, 0.3, 0.6 and 2.4) ng/ml. These standards with lower beryllium concentration can be prepared by dilution of the stock standards mentioned in the note above. The standards are prepared for analysis by adding 0.67 mL of beryllium stock standard into 1.33 mL of detection solution (3-fold dilution). This dilution will result in 0, 0.05, 0.1, 0.2 and 0.8 ppb of beryllium in these standards. Please see Table 3. MCE air filters and cellulosic capsules with MCE filters were spiked with a solution of beryllium acetate and analyzed in triplicate after extracting beryllium in 5ml of 1% ABF solution at 85°C for 60 minutes and then mixed with lysine-free dye solution in a 3-fold dilution. The results are shown in Table 4. The difference in the average fluorescent signals from blanks and the 0 ppb standard were subtracted from the fluorescent readings of the spiked filters.

NOTE: If alternative ratios of dissolution solution and detection solution are used for sample preparation, then a similar ratio for calibration solutions is required.

9. Analyze a stock standard, a reagent blank, and a media blank at least once every 20 samples. Ensure that the concentration range of the stock standards spans the beryllium levels found in the samples.
10. Analyze one media spike and one quality control blind spike per 20 samples (minimum of three each per sample set) to insure that percent recovery is in control (e.g., 100 ± 15). Correct sample results for the average recovery if it differs significantly from 100 %.

NOTE: If it is suspected that beryllium oxide may be present, then it is recommended to use beryllium oxide for media and blind spikes.

MEASUREMENT:

11. For each sample, obtain the fluorescence intensity at λ_{\max} or with optical filter for appropriate wavelength.
12. If the fluorescence response for any of the samples is above the range of responses for the stock standards, dilute the sample filtrate with dissolution solution, reanalyze, and apply the appropriate dilution factor (D) in subsequent calculations.

CALCULATIONS:

13. Obtain the solution concentration for each sample filtrate, C_s (ng/mL), and the average media blank, C_b (ng/mL) from the calibration graph.
14. Using the dissolution volumes (normally 5 mL) of sample, V_s (mL), and media blank, V_b (mL), calculate the concentration, C ($\mu\text{g}/\text{m}^3$), of Be in the air volume sampled, V (L), while accounting for the dilution factor (D).

$$C = D \times (C_s V_s - C_b V_b) / V \text{ ng/L or } \mu\text{g}/\text{m}^3$$

NOTE: Tables 1, 2 and 3 can be used for correlating the amount of beryllium in the sampling media with the concentrations of beryllium in solution. Table 1 is for testing media with 0.2 μg to 4 μg of beryllium at 20-fold dilution; Table 2 is for testing media with 0.02 μg to 0.4 μg of beryllium at 5-fold dilution; and Table 3 is for testing media with 0.0005 μg to 0.012 μg of beryllium at 3-fold dilution. Lysine-free dye solution may be used for any of these dilutions, but for 3x dilution, lysine-free dye solution must be used.

Table 1. Correlation of amount of Be in sampling media with Be concentration in stock standard and Be concentration as analyzed, assuming 0.1 mL of sample or stock standard is added to 1.9 mL of detection solution (20-fold dilution).

| Be concentration in stock standard (ng/mL) | Be concentration as analyzed (ng/mL) | Amount of Be in the media* (ng) |
|--|--------------------------------------|---------------------------------|
| 0 | 0 | 0 |
| 10 | 0.5 | 50 |
| 40 | 2 | 200 |
| 200 | 10 | 1000 |
| 800 | 40 | 4000 |

*Equals stock standard Be concentration (ng/mL) \times volume (5 mL) of dissolution solution used to extract media.

Table 2. Correlation of amount of Be in sampling media with Be concentration in stock standard and Be concentration as analyzed, assuming 0.4 mL of sample or stock standard is added to 1.6 mL of detection solution (5-fold dilution).

| Be concentration in stock standard (ng/mL) | Be concentration as analyzed (ng/mL) | Amount of Be in the media* (ng) |
|--|--------------------------------------|---------------------------------|
| 0 | 0 | 0 |
| 1 | 0.2 | 5 |
| 4 | 1 | 25 |
| 20 | 4 | 100 |
| 80 | 16 | 400 |

*Equals stock standard Be concentration (ng/mL) \times volume (5 mL) of dissolution solution used to extract media.

Table 3. Correlation of amount of Be in sampling media with Be concentration in stock standard and Be concentration as analyzed, assuming 0.67 mL of sample or stock standard is added to 1.33 mL of lysine-free dye solution (3-fold dilution).

| Be concentration in stock standard (ng/mL) | Be concentration as analyzed (ng/mL) | Amount of Be in the media* (ng) |
|--|--------------------------------------|---------------------------------|
| 0 | 0 | 0 |
| 0.15 | 0.05 | 0.75 |
| 0.3 | 0.1 | 1.5 |
| 0.6 | 0.2 | 3 |
| 2.4 | 0.8 | 12 |

*Equals stock standard Be concentration (ng/mL) × volume (5 mL) of dissolution solution used to extract media.

Table 4: Analysis of beryllium spiked MCE filters and cellulosic filter capsule inserts using 3-fold dilution of the extraction solution with lysine-free dye solution. Beryllium concentration of standard solutions after mixing with the dye solutions were 0, 0.05, 0.1, 0.2 and 0.8ng/ml. Samples analyzed in triplicate, averages and standard deviations shown.

| Nominal Be concentration on the spiked filter, µg | Be concentration as analyzed on the spiked MCE filter (µg) | Be concentration as analyzed on the spiked cellulosic internal capsule insert (µg) |
|---|--|--|
| 0 | 0.0000±1.2E-5 | -0.0001±3.7E-5 |
| 0.0005 | 0.00044±1.9E-5 | 0.0005±3.6E-5 |
| 0.001 | 0.0009±2.4E-5 | 0.0009±2.6E-5 |
| 0.002 | 0.0018±4.0E-5 | 0.0020±1.1E-4 |
| 0.005 | 0.0043±1.3E-5 | 0.0045±6.4E-4 |
| 0.05 | 0.045±5.5E-4 | 0.046±1.0E-3 |
| 0.48 | 0.42±3.5E-3 | 0.45±4.0E-3 |

Table 5. Other published OELs and guidelines†

| Country or organization | 8 Hour inhalation exposure limit ($\mu\text{g}/\text{m}^3$) | Short term inhalation exposure limit ($\mu\text{g}/\text{m}^3$) |
|--|---|---|
| Germany | 0.06 (respirable); 0.14 (inhalable) | 0.06 (respirable); 0.14 (inhalable) |
| ACGIH TLV® * | 0.05 | |
| Australia, France, New Zealand, Singapore, Sweden, Switzerland, United Kingdom | 2 | |
| Canada (Quebec) | 0.15 | |
| Ireland, Poland, Spain | 0.2 | |
| Czech Republic, Japan, Latvia, Norway | 1 | |
| Finland | 0.1 | 0.4 |
| China | 0.5 | 0.1 |
| Austria | 2 | 0.8 |
| Denmark | 1 | 2 |
| Hungary | 2 | 2 |
| Belgium, Canada (Ontario), Korea (Republic of) | 2 | 10 |

*Abbreviations: ACGIH = American Conference of Governmental Industrial Hygienists, TLV® = Threshold Limit Value

†Occupational exposure limits and guidelines other than NIOSH's recommended exposure limit (REL) have not been reviewed by NIOSH. Professional society and other country exposure limits and guidelines are provided as an aid to NMAM users seeking additional information. Inclusion of these standards and guidelines does not constitute endorsement by NIOSH.

EVALUATION OF METHOD:

The method was evaluated [1,2,7] in accordance with published guidelines [9]. Experiments were conducted using an Ocean Optics® portable fluorescence device with the following components:

USB 200 spectrometer with spectral grating #2 (UV/Vis 600), LS-1 lamp (380 nm) in LS-450 housing, UV-2 casting, OFLV linear filter 200-850, L2 collection lens and slit-200.

Tests were carried out in relative irradiance mode using 2- or 5-second integration times.

The method was evaluated using beryllium oxide spiked onto mixed cellulose ester (MCE) filters at levels of (0, 0.02, 0.1, 0.2, 0.3, 0.4, 1.5, 3.0, and 6.0) μg (five samples at each level) [2,6].

Long-term stability of samples was verified from spikes (number [n] = 30) of 0.1 μg Be on MCE filters. Samples were analyzed at day one (n = 12) and then one week (n = 6), ten days (n = 3), two weeks (n = 3), three weeks (n = 3), and one month (n = 3) after spiking. No diminution of fluorescence signal was observed from samples prepared and analyzed after having been stored for up to thirty days.

Interference tests were carried out using solutions of 0 nmol/L, 100 nmol/L, and 1.0 $\mu\text{mol}/\text{L}$ Be in the presence of 0.4 mmol/L Al, Ca, Co, Cu, Fe, Ti, Li, Ni, Pb, Sn, U, V, W, or Zn (separate experiments were carried out for each potential interferant). Interlaboratory evaluations of the method were also performed [10, 11].

The method using the lysine-free detection solution on MCE filters and SOLU-SERT™ internal capsules was compared and tested (with the detection solution containing lysine for comparison) in Table 4 and this was carried out on a Glomax™ spectrometer (From Turner Biosystems, Sunnyvale, CA) with an emission filter of 475 ± 5 nm and the excitation was at 360 nm.

REFERENCES:

- [1] Agrawal A, Cronin J, Tonazzi J, McCleskey TM, Ehler DS, Minogue EM, Whitney G, Brink C, Burrell AK, Warner B, Goldcamp MJ, Schlecht PC, Sonthalia P, Ashley K [2006]. Validation of a standardized portable fluorescence method for determining trace beryllium in workplace air and wipe samples. *J Environ Monit* 8: 619- 624.
- [2] Ashley K, Agrawal A, Cronin J, Tonazzi J, McCleskey TM, Burrell AK, Ehler DS [2007]. Ultra-trace determination of beryllium in occupational hygiene samples by ammonium bifluoride extraction and fluorescence detection using hydroxybenzoquinoline sulfonate. *Anal Chim Acta* 584: 281-286.
- [3] NIOSH [1994]. Elements by ICP (nitric/perchloric acid ashing): Method 7300 (supplement issued 3/15/03). In: NIOSH manual of analytical methods. 4th ed. Cincinnati, OH: U.S. Department of Health and Human Services, Public Health Service, Centers for Disease Control and Prevention, National Institute for Occupational Safety and Health, DHHS (NIOSH) Publication No. 94-113.
- [4] ASTM [2015]. D7202 – Standard test method for determination of beryllium in the workplace using field-based extraction and fluorescence detection. West Conshohocken, PA: ASTM International.
- [5] Matsumiya H, Hoshino H, Yotsuyanagi T [2001]. A novel fluorescence reagent, 10-hydroxybenzo[h]quinoline-7-sulfonate, for selective determination of beryllium(II) ion at pg cm⁻³ levels. *Analyst* 126:2082–2086.
- [6] Goldcamp MJ, Goldcamp DM, Ashley K, Fernback JE, Agrawal A, Millson M, Marlow D, Harrison K [2009]. Extraction of beryllium from refractory beryllium oxide with dilute ammonium bifluoride and determination by fluorescence – A multi-parameter performance evaluation. *J Occup Environ Hyg* 6: 735-744.
- [7] McCleskey TM, Agrawal A, Ashley K [2007]. Backup data—method nos. 7704 and 9110 / beryllium, Issue 1. NIOSH Docket Office, Cincinnati, Ohio, e-mail: NIOSHDocket@cdc.gov.
- [8] Agrawal A, Adams LL, Agrawal A, Cronin JP, Tonazzi JCL, Duran BL [2011]. Beryllium measurement by optical fluorescence in samples contaminated by fluorescent impurities. *J ASTM Int* 8(8), 14 pp. [JAI 103411].
- [9] Kennedy ER, Fischbach TJ, Song R, Eller PM, Shulman SA [1995]. Guidelines for air sampling and analytical method development and evaluation. Cincinnati, OH: U.S. Department of Health and Human Services, Public Health Service, Centers for Disease Control and Prevention, National Institute for Occupational Safety and Health, DHHS (NIOSH) Publication No. 95-117.
- [10] Ashley K, McCleskey TM, Brisson MJ, Goodyear G, Cronin J, Agrawal A [2005]. Interlaboratory evaluation of a portable fluorescence method for the measurement of trace beryllium in the workplace. *J ASTM Int* 2(9), 8 pp., Paper ID JAI13156.
- [11] Oatts TJ, Hicks CE, Adams AR, Brisson MJ, Youmans-McDonald LD, Hoover MD, Ashley K [2012]. Preparation, certification and interlaboratory analysis of workplace air filters spiked with high-fired beryllium oxide. *J Environ Monit* 14: 391-401.

METHOD REVISED BY:

T. Mark McCleskey, Los Alamos National Laboratory, Los Alamos, NM; Kevin Ashley, CDC/NIOSH, Division of Applied Research and Technology; Anoop Agrawal, Berylliant Inc., Tucson, AZ.

Disclaimer: Mention of any company or product does not constitute endorsement by NIOSH. In addition, citations to websites external to NIOSH do not constitute NIOSH endorsement of the sponsoring organizations or their programs or products. Furthermore, NIOSH is not responsible for the content of these websites. All web addresses referenced in this document were accessible as of the publication date.



PARTICULATE FLUORIDES and HYDROFLUORIC ACID by Ion Chromatography

7906

MW: F, 18.998 (HF, 20.01)

CAS (HF): 7664-39-3

RTECS: (HF) MW7875000

METHOD: 7906, Issue 2

EVALUATION: FULL

Issue 2: 20 May 2014

Issue 1: 15 August 1994

U. S. OELs

OSHA : 2.5 mg/m³ (fluorides); 3 ppm (HF)

NIOSH: 2.5 mg/m³ (fluorides);

3 ppm (HF), STEL (HF): 6 ppm

Other OELs: [1,2]

PROPERTIES: HF: gas; mp = -83.1 °C; bp = 19.5 °C; sp. gr. 0.987; VP = 783 mm Hg (104.4 kPa).

Fluoride salts liberate HF vapor in the presence of acids.

SYNONYMS: Hydrogen fluoride; hydrofluoric acid; Sodium fluoride (CAS #7681-49-4)

APPLICABILITY: The working range is (at least) 0.1 to 8 mg/sample for a 250 Liter air sample.

INTERFERENCES: Co-sampled formate and acetate compounds in the work environment can cause a positive interference; thus detection by ion selective electrodes is a suitable alternative if airborne formate and acetate are expected. Cations that form insoluble fluorides, such as Ca²⁺, Fe³⁺, and Al³⁺ can cause negative interferences. Recovery of gaseous HF is reduced at high humidity.

OTHER METHODS: This method updates NIOSH 7906 [7] by providing full method accuracy information, and specifies the use of an impregnated filter instead of a treated cellulose pad. The procedure, which is consistent with ISO 21438-3 [6], replaces NIOSH 7903 [8] for the determination of particulate fluorides and gaseous HF in workplace air samples. The advantages of this method are that it can allow for the collection of the inhalable fraction of particulate fluorides by means of the pre-filter (housed within an optional inhalable sampler) and it can provide for lower limits of detection and quantitation for gaseous HF due to higher sampling flow rates. NIOSH 7902 [9] and ASTM D4765 [10] are alternative methods that are recommended for insoluble fluorides, which rely on detection of F⁻ by ion-selective electrode.

REAGENTS:

1. Water, deionized (DI), ≥ 18 M Ω -cm resistivity
2. Sodium carbonate (Na₂CO₃), anhydrous, American Chemical Society (ACS) analytical grade
3. Sodium hydrogen carbonate (NaHCO₃), ACS analytical grade
4. Filter impregnation solution (0.75 M Na₂CO₃); Dissolve 7.95 g Na₂CO₃ in deionized water and swirl to mix. Then bring to 100 mL in a volumetric flask, stopper and mix thoroughly.
5. Eluent stock solution: 0.8 M Na₂CO₃ / 0.1 M NaHCO₃; Dissolve 16.96 g Na₂CO₃ and 1.68 g NaHCO₃ in deionized water and swirl to mix. Then bring to 200 mL in a volumetric flask, stopper and mix thoroughly.
6. Eluent solution: 8 mM Na₂CO₃ / 1 mM NaHCO₃; Transfer 10 mL of 0.8 M Na₂CO₃ / 0.1 M NaHCO₃ stock solution to a 1 Liter volumetric flask, dilute to the mark with deionized water, stopper and mix thoroughly. Prepare fresh eluent solution weekly.
7. Fluoride (F⁻) standard solution, 1000 mg/L
8. Calibration stock solution, 100 mg/mL (as the anion): Place a 10 mL aliquot of fluoride standard solution into a 100 mL volumetric flask, dilute to the mark and mix thoroughly. The solution is stable for at least 4 weeks at room temperature.
9. To prepare the impregnated filter, evenly distribute 120 μ L 0.75 M Na₂CO₃ over the surface of the filter and allow to dry at room temperature for several hours.

*See Special Precautions

EQUIPMENT:

1. Sampler: 37-mm diameter cellulose nitrate pre-filter, 0.8 μ m pore size, 37-mm impregnated cellulose nitrate filter. The untreated filter collects particulate fluorides, while the impregnated filter collects HF vapor. Arrange the filters serially (with the pre-filter upstream of the impregnated filter) in a 37-mm diameter 3-piece chemically inert cassette filter holder.
2. Personal sampling pump, 1 to 2 L/min, with flexible connecting tubing
3. Ion chromatograph (IC), with pre-column (50 mm by 4.0 mm), anion-exchange column (200 mm by 4.0 mm), suppressor column (4 mm) and conductivity detector; and connected to data processing unit
4. Ultrasonic bath
5. Vessels, 10-mL, inert plastic, with screw caps
6. Volumetric flasks, 25- to 1000 mL
7. Pipets, 50- to 10000 μ L
8. Beakers, 25- to 100 mL
9. Filtration apparatus, with filter funnel
10. Disposable filters, cellulosic, 0.45 μ m pore size
11. Styrene-based sulfonic acid resin cartridges
12. Water purification system, to prepare greater than or equal to 18 M Ω -cm resistivity deionized water
13. Bottles, polyethylene, 100 mL
14. Syringes, plastic, 5 mL and/or 10 mL
15. Syringe filter cartridges, with 0.8- μ m pore size polytetrafluoroethylene (PTFE) membrane filters
16. Micro-syringes, 50 μ L, with 60 mm x 0.6 mm needles
17. Auto-sampler vials, polypropylene, 0.75 mL capacity.

SPECIAL PRECAUTIONS: Acids, particularly HF, are extremely corrosive to skin, eyes, and mucous membranes. HF will attack glass. Plastic labware is recommended. Wear gloves, lab coat, and safety glasses while handling acids. All work should be performed with adequate ventilation for personnel and equipment. It is imperative that acid be added to water in order to avoid a violent exothermic reaction [11,12].

SAMPLING, SAMPLE TRANSPORT AND STORAGE:

1. Prior to sampling, load each clean sampler, first with a sampling (impregnated) filter, then with a pre-filter, separating the filters with a spacer. Ensure that the configuration in which the filters are loaded leads to the sampled air passing first through the pre-filter and then through the sampling filter.
2. Calibrate each personal sampling pump with a representative sampler in the line.
3. Sample at an accurately known flow rate between 1 to 2 mL/min for a total sample size of 15 to 1000 L. Avoid sampler overloading.
4. After sampling, remove the filters from the cassette and place them in screw-cap plastic vessels. For the pre-filter portion: With approximately 2 mL eluent(extraction) solution, rinse material from the inside surfaces of the pre-filter portion of the cassette into the vessel. Add eluent solution into the vessels until a final volume of 10 mL is reached.
5. Submit at least three blank untreated filters and three blank impregnated filters as field blanks for each set of samples collected per day. Handle these in the same way as the field samples; i.e., place each filter into a vessel, add 10 mL of eluent solution and ship it to the lab along with the remaining samples.
6. Refrigerate all samples that are to be stored overnight (or longer) prior to shipment to the laboratory. Ship all samples to the laboratory in accordance with established chain-of-custody procedures [13].
7. Refrigerate the samples immediately upon receipt at the lab until ready for analysis.
8. Analyze samples within 2 weeks of receipt. The samples can be stored at room temperature for one week; for longer storage, refrigerate the samples (4 °C).

SAMPLE PREPARATION AND MEASUREMENT:

9. Remove sample vessels from storage and bring them to room temperature.
10. Sonicate the samples in an ultrasonic bath for at least 15 minutes and allow to cool for at least 30 minutes.
11. Using 5- or 10-mL syringes, filter each sample extract solution through a PTFE filter and a styrene-based sulfonic acid resin cartridge (follow the manufacturer's instructions), discard the first two milliliters and place the remaining solution in clean plastic vessels.

CALIBRATION AND QUALITY CONTROL:

12. With dilution of the calibration stock solution in eluent solution, prepare calibration working standard solutions covering the range of approximately 0.4 to 8 µg/mL of fluoride. Store working standards in tightly sealed polyethylene bottles. Prepare fresh working standards biweekly.
13. Calibrate the ion chromatograph with at least six working standards covering the range of (at least) 0.4 to 8 µg/mL of fluoride per sample by preparing a calibration graph of anion peak height (mm or µS) vs. concentration (µg/mL).
14. Analyze working standards together with samples, reagent blanks and field blanks at a frequency of at least 1 per 20 samples (3 minimum of each). Cellulose nitrate filters demonstrate variable batch-dependent blank values, thus media blank correction is essential.

MEASUREMENT

15. Set the ion chromatograph to recommended eluent flow rate, (e.g. 1.0 mL/min or approximately 13 MPa pressure), and other conditions as specified by the instrument manufacturer.
16. Inject a sample aliquot (e.g. 50 µL) into the chromatograph and measure the peak height of the fluoride peak. If the peak height exceeds the linear calibration range, dilute with eluent, reanalyze and apply the appropriate dilution factor in calculations.

CALCULATIONS:

17. Calculate the mass concentration of fluoride, C (mg/m³), in the air volume sampled, V (L):

$$C = \left\{ \frac{(C_1 * V_1 * F_d) - (C_0 * V_0)}{V * \eta} \right\} * F_c$$

where:

C_0 = mean concentration, in µg/mL, of fluoride in the field blank test solutions;

C_1 = concentration, in µg/mL, of fluoride in the sample test solution;

V = volume, in liters, of the air sample;

V_0 = volume, in mL, of the field blank test solutions;

V_1 = volume, in mL, of the sample test solutions;

F_d = dilution factor for each sample test solution;

F_c = 1.053 = conversion factor to convert from fluoride to HF concentration (if applicable);

η = recovery.

EVALUATION OF METHOD:

This updates Issue 1, NIOSH 7906 [7], by providing full method accuracy information, and specifies the use of an impregnated filter instead of a treated cellulose pad. The procedure described in issue 2 of NIOSH 7906, which is consistent with ISO 21438-3 [6], also replaces NIOSH 7903 [8] for the determination of particulate fluorides and gaseous HF in workplace air samples.

Recovery of 100% ± 2% was found after sample collection for both F⁻ and HF [3,5,6], and no breakthrough of HF was observed from impregnated filters for up to 5 mg fluoride [6,14]. The component of the coefficient of variation of the method that arises from analytical variability, determined from the analysis of spiked filters, was 2.4% to 5.6% for HF and 1.7% to 3.3% for fluorides [3,6]. Laboratory testing with test atmospheres of HF (0.5 to 5 mg/m³) demonstrated quantitative sampling efficiencies (greater than 95%) at relative humidity (RH) of 20% to 60%, but recovery was around 60% at relative humidity of 80%.

The recovery of HF as an effect of relative humidity (RH) greater than 60 percent can be calculated as follows (see also Figure 1):

$$\eta = \frac{[226.5 - (2.0914 * RH)]}{100}$$

No effect of humidity (RH from 20% to 80%) was observed on recovery of particulate fluoride over the concentration range of 0.3 to 5 mg/m³. Results for repeatability and reproducibility of the method for test atmospheres of hydrogen fluoride and fluoride aerosol (Relative humidity was approximately 50%) are shown in Table I. The method has been successfully applied in independent investigations [14] and

has been promulgated as an International Standard [6]. The back-up data and user check reports are references 3 and 14 respectively.

REFERENCES:

- [1] ACGIH [2013]. TLVs and BEIs based on the documentation of the Threshold Limit Values for chemical substances and physical agents and Biological Exposure Indices. Cincinnati, Ohio: American Conference of Governmental Industrial Hygienists. [www.acgih.org]. Data accessed April 2014.
- [2] Institut für Arbeitsschutz der Deutschen Gesetzlichen Unfallversicherung [2013]. GESTIS database on international limit values for hazardous substances (German Social Accident Insurance). Sankt Augustin, FRG: [http://www.dguv.de/ifa/GESTIS]. Data accessed April 2014.
- [3] Breuer D, Gusbeth K [2005]. Hydrogen fluoride and fluorides. In: The MAK-Collection Part III: Air monitoring methods. (Deutsche Forschungsgemeinschaft) Vol. 9. Weinheim, FRG: Wiley-VCH. pp. 105-118.
- [4] ISO (International Organization for Standardization) [1995]. ISO Guide 98: Guide to the expression of uncertainty in measurement. Geneva, Switzerland: ISO).
- [5] Breuer D [2006]. Fluoride und fluorwasserstoff (Fluorides and hydrogen fluoride), in BGIA Working Folder, Sheet No. 7512. Berlin, FRG: Erich-Schmidt Verlag. ISBN 3-503-020853.
- [6] ISO (International Organization for Standardization) [2010]. ISO 21438-3, Workplace air — Determination of inorganic acids by ion chromatography — Part 3: Hydrofluoric acid and particulate fluorides. Geneva, Switzerland: International Organization for Standardization (ISO).
- [7] NIOSH [1994]. Fluorides, aerosol and gas, by IC: Method 7906. In: Eller PM, Cassinelli ME, eds. NIOSH Manual of analytical methods, 4th ed., Cincinnati, OH: U.S. Department of Health and Human Services, Centers for Disease Control and Prevention, National Institute for Occupational Safety and Health, DHHS (NIOSH). Publication No. 94-113. [www.cdc.gov/niosh/nmam].
- [8] NIOSH [1994]. Acids, inorganic: Method 7903. In: Eller PM, Cassinelli ME, eds. NIOSH Manual of analytical methods, 4th ed., Cincinnati, OH: U.S. Department of Health and Human Services, Centers for Disease Control and Prevention, National Institute for Occupational Safety and Health, DHHS (NIOSH). Publication No. 94-113. [www.cdc.gov/niosh/nmam].
- [9] NIOSH [1994]. Fluorides, aerosol and gas, by ISE: Method 7902. In: Eller PM, Cassinelli ME, eds. NIOSH Manual of analytical methods, 4th ed., Cincinnati, OH: U.S. Department of Health and Human Services, Centers for Disease Control and Prevention, National Institute for Occupational Safety and Health, DHHS (NIOSH). Publication No. 94-113. [www.cdc.gov/niosh/nmam].
- [10] ASTM International [2008]. ASTM D4765, Standard test method for fluorides in workplace atmospheres by ion-selective electrodes. West Conshohocken, PA: ASTM International.[11] NIOSH [2005]. NIOSH Pocket guide to chemical hazards. Barsan ME, ed. Cincinnati, OH: US Department of Health and Human Services, Centers for Disease Control and Prevention, National Institute for Occupational Safety and Health, DHHS (NIOSH) Publication No. 2005-149.
- [12] Furr AK, ed. [1995] CRC Handbook of laboratory safety, 4th ed. Boca Raton, FL: CRC Press.
- [13] ASTM International [2010]. ASTM D4840, Standard Guide for Sampling Chain of Custody Procedures. West Conshohocken, PA: ASTM International.
- [14] Demange M, Oury V, Rousset D [2011]. Evaluation of sampling methods for measuring exposure to volatile inorganic acids in workplace air. Part 2 – sampling capacity and breakthrough tests for sodium carbonate-impregnated filters. J Occup Environ Hyg. 8:642-651.
- [15] Comité Européen de Normalisation (CEN) [2012]. EN 482, Workplace exposure — General requirements for the performance of procedures for the measurement of chemical agents. Brussels, Belgium: Comité Européen de Normalisation (CEN).

METHOD WRITTEN BY:

Dietmar Breuer, Dr. rer. nat., and Petra Heckmann, Institute for Occupational Safety and Health of the German Social Accident Insurances, Sankt Augustin, Germany; and Kevin Ashley, Ph.D., NIOSH/DART

Disclaimer: Mention of any company or product does not constitute endorsement by NIOSH. In addition, citations to websites external to NIOSH do not constitute NIOSH endorsement of the sponsoring organizations or their programs or products. Furthermore, NIOSH is not responsible for the content of these websites. All web addresses referenced in this document were accessible as of the publication date.

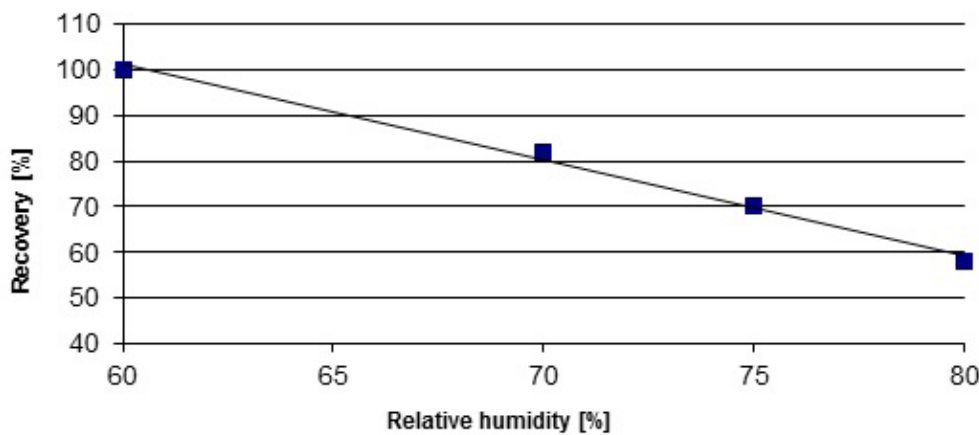

FIGURE 1. HF recovery as function of relative humidity

TABLE 1. Performance evaluation for HF and F⁻ ion measurements from test atmospheres [5]

| Analyte | Concentration (mg/m ³) | S _r ¹ (n = 6) | RSD ² (%) | U ³ |
|----------|------------------------------------|-------------------------------------|----------------------|----------------|
| HF | 0.25 | 0.007 | 3.1 | 0.22 |
| HF | 1.2 | 0.044 | 2.8 | 0.21 |
| HF | 2.3 | 0.026 | 1.1 | 0.20 |
| HF | 5.0 | 0.099 | 2.0 | 0.11 |
| Fluoride | 0.04 | 0.002 | 3.8 | 0.19 |
| Fluoride | 0.52 | 0.006 | 1.3 | 0.12 |
| Fluoride | 2.95 | 0.009 | 0.3 | 0.11 |
| Fluoride | 5.9 | 0.065 | 1.1 | 0.11 |

1 Standard deviation for 6 test samples

2 Relative standard deviation

3 Expanded measurement uncertainty; k = 2 (calculated in accordance with EN 482 [15])

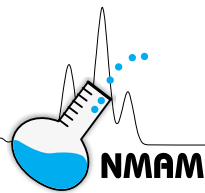

VOLATILE ACIDS by Ion Chromatography

7907

(Hydrogen Chloride, Hydrogen Bromide, Nitric Acid)

Formulae: 1. HCl;
2. HBr;
3. HNO₃

MW: Table 1

CAS: Table 1

RTECS: Table 1

| | | |
|---|----------------------------|-----------------------------|
| METHOD: 7907, Issue 1 | EVALUATION: FULL | Issue 1: 20 May 2014 |
| OSHA: Table 2 NIOSH: Table 2 Other OELs: [1,2] | PROPERTIES: Table 3 | |

SYNONYMS: 1) HCl: Hydrochloric acid, salt acid, muriatic acid; 2) HBr: Hydrobromic acid; 3) HNO₃: azotic acid

| SAMPLING | | MEASUREMENT | |
|--|--|--|--|
| SAMPLER: Two (2) FILTERS in series separated with a chemically inert spacer: (1) pre-filter: 37-mm diameter quartz fiber filter; (2) sampling filter: 37-mm diameter quartz fiber filter impregnated with 500 µl Na ₂ CO ₃ solution (1 M) | | TECHNIQUE: ION CHROMATOGRAPHY (IC) with conductivity detection | |
| FLOW RATE: 2 L/min | | ANALYTES: Chloride (Cl ⁻), bromide (Br ⁻) and nitrate (NO ₃ ⁻) ion | |
| VOL-MIN: 30 L -MAX: 600 L | | EXTRACTION: Aqueous solution of sodium carbonate / sodium hydrogen carbonate | |
| SHIPMENT: Routine | | INJECTION VOLUME: 25 µL | |
| SAMPLE STABILITY: Stable for 1 week @ 20 °C and 4 °C thereafter to at least 28 days [3] | | ELUENT: 3.1 mM Na ₂ CO ₃ / 0.35 mM NaHCO ₃ , flow rate 1.5 mL/min | |
| BLANKS: 3 blanks minimum per set | | COLUMNS: Pre-column, anion-exchange column and suppressor column | |
| ACCURACY* | | CALIBRATION RANGE: Chloride, bromide and nitrate at 0.4 mg/mL to 4 mg/mL | |
| RANGE STUDIED: HCl: 0.04 to 1.6 mg/sample; HBr: 0.03 to 2.3 mg/sample; HNO ₃ : 0.04 to 1.5 mg/sample | | ESTIMATED LOD: 0.003 mg/sample for all three acids; or 0.0012 mg/m ³ for a 240 L air volume [4] | |
| BIAS*: Negligible [4] | | PRECISION (\bar{S}_r): 0.01 for all three acids [3] | |
| OVERALL PRECISION ($\hat{S}_{r,T}$)*: HCl, 0.06; HBr, 0.06; HNO ₃ , 0.07 [4] | | | |
| EXPANDED UNCERTAINTY*: Less than 12% for HCl and HBr; less than 14 % for HNO ₃ [3,5] | | | |
| *Accuracy calculations were determined using ISO Guide 98 [5] rather than the traditional NIOSH accuracy criterion. | | | |

APPLICABILITY: The working range is (at least) 0.01 to 2.0 mg/sample for a 240 Liter air sample [3,4].

INTERFERENCES: Inorganic acids can react with co-sampled particulate matter on the pre-filter, leading to low results. One such example is in the galvanizing industry, where the presence of zinc oxide can be a major confounding factor in the measurement of HCl. Potentially interfering particulate chlorides and nitrates removed by the pre-filter can react with the sampled acids and liberate HCl and HNO₃ that is subsequently collected on the sampling filter, leading to high results [6].

OTHER METHODS: This procedure, which is consistent with ISO 21438-2 [4], replaces NIOSH 7903 [7] for the determination of HCl, HBr and HNO₃ in workplace air samples by IC. The main advantage of this method is that it provides for lower limits of detection and quantitation for volatile acids due to higher sampling flow rates.

REAGENTS:

1. Water, deionized (DI), ≥ 18 M Ω -cm resistivity
2. Sodium carbonate (Na₂CO₃), anhydrous, American Chemical Society (ACS) analytical grade
3. Sodium hydrogen carbonate (NaHCO₃), ACS analytical grade
4. Extraction & eluent stock solution: 0.62 M Na₂CO₃ / 0.069 M NaHCO₃; Dissolve 13.14 g Na₂CO₃ and 1.15 g NaHCO₃ in 50 mL of deionized water and swirl to mix. Then bring to 200 mL in a volumetric flask, stopper and mix thoroughly.
5. Extraction and eluent solution; 0.0031 M Na₂CO₃ / 0.00035 M NaHCO₃; transfer 10 mL 0.62 M Na₂CO₃ / 0.069 M NaHCO₃ stock solution to a 2 liter volumetric flask, dilute to the mark with deionized water, stopper and mix thoroughly.
6. Chloride (Cl⁻), bromide (Br⁻) and nitrate (NO₃⁻) standard solutions, 1000 mg/L.
7. Calibration stock solution, 100 μ g/mL (as the anion): Transfer 10 mL aliquots of chloride, bromide and nitrate standard solution into a 100 mL volumetric flask, dilute to the mark with deionized water, stopper and mix thoroughly.
8. Sodium carbonate solution, for impregnation of 37 mm diameter quartz fiber filters, 1 mol/L: dissolve 10.6 g Na₂CO₃ in deionized water, quantitatively transfer the solution into a 100 mL volumetric flask, dilute to the mark with deionized water, stopper and mix thoroughly.
9. Preparation of the sampling filter: Apply 500 μ L of the sodium carbonate solution, 1 mol/L, evenly on the 37 mm quartz fiber filter and allow to dry for 6 hours in a desiccator. (See NOTE 1, Step 1, p 7907-3.) Good for 14 days.

*See Special Precautions

EQUIPMENT:

1. Sampler: filter, 37-mm diameter quartz fiber impregnated with 500 μ L 1 M Na₂CO₃; and pre-filter, 37-mm diameter quartz fiber filter separated by a spacer in a chemically inert cassette filter holder
2. Spacers, of 37-mm diameter suitable for use with the samplers, manufactured from a chemically inert material, e.g. polypropylene sleeves
3. Personal sampling pump, 1 to 5 L/min, with flexible connecting tubing
4. Ion chromatograph (IC), with pre-column (50 mm by 4.0 mm), anion-exchange column (200 mm by 4.0 mm), suppressor column (4 mm) and conductivity detector; and connected to data processing unit
5. Ultrasonic bath
6. Vessels, 15-mL, plastic, with screw caps
7. Volumetric flasks, 10- to 2000 mL
8. Pipets, 10 to 5000 μ L
9. Beakers, 25 to 100 mL
10. Water purification system, to prepare ≥ 18 M Ω -cm resistivity deionized water
11. Bottles, polyethylene, 100 mL
12. Syringes, plastic, 5 mL
13. Syringe filter cartridges, with 0.45- μ m pore size polytetrafluoroethylene (PTFE) membrane filters
14. Micro-syringes, 50 μ L, with 60 mm x 0.6 mm needles
15. Auto-sampler vials, with slotted septum, 2 mL capacity
16. Analytical balance, with capability of weighing to nearest 0.01 mg

SPECIAL PRECAUTIONS: Wear gloves, lab coat, and safety glasses while handling acids. All work should be performed with adequate ventilation for personnel and equipment. It is imperative that acid be added to water in order to avoid a violent exothermic reaction. Avoid direct contact since acids are both corrosive and irritants to eyes, skin, and the respiratory system [8,9].

SAMPLING, SAMPLE TRANSPORT AND STORAGE:

1. Prior to sampling, load each clean sampler, first with a sampling (impregnated) filter, then with a pre-filter, separating the filters with a spacer. Ensure that the configuration in which the filters are loaded leads to the sampled air passing first through the pre-filter and then through the sampling filter.
Note 1: Three-piece polystyrene cassettes are appropriate, with the middle ring section of the cassette acting as the spacer. Impregnated filters that are stored in a desiccator can be prepared up to 14 days prior to their use for sampling.
Note 2: Silica gel sorbent tubes [7] can be used in lieu of impregnated filters, but each sorbent tube must be preceded by a pre-filter.
2. Calibrate each personal sampling pump with a representative sampler in the line.
3. Sample accurately at 2 L/min for a total sample size of 30 to 500 L. Avoid sampler overloading [6].
4. Transport the samples to the laboratory in a manner that prevents contamination or damage to the filters.
5. Submit at least three blank impregnated filters as field blanks for each set of samples collected per day. Handle these in the same way as the field samples.
6. Ship all samples to the laboratory in accordance with established chain-of-custody procedures [10].
7. The samples can be stored at room temperature for one week; for longer storage, refrigerate the samples (4 °C).
8. Analyze samples between 4 days and 4 weeks of sample collection.

SAMPLE PREPARATION:

9. Prior to carrying out sample dissolution, store the sampling filter for at least four days (to avoid nitric acid losses).
10. Remove sample cassettes from storage and bring them to room temperature. Discard the pre-filters.
NOTE: If desired, the pre-filters can be analyzed for determination of particulate chlorides, bromides and nitrates. If this analysis is carried out, it is recommended to rinse the inside surfaces of the sampler with a few mL of DI water so as to include wall deposits along with material collected on the prefilter.
11. Place the sampling filters (i.e., impregnated filter samples) in 15-mL plastic screw-cap vessels and add 10 mL of deionized water to each sample. Securely cap the vessels.
12. Sonicate the samples in an ultrasonic bath for at least 15 minutes, and allow to cool for approx. 30 minutes.
13. Using 5-mL syringes, filter 5-mL aliquots of each sample extract solution through a PTFE filter into clean auto-sampler vials.

CALIBRATION AND QUALITY CONTROL:

14. With dilution of the calibration stock solution in eluent solution, prepare calibration working standard solutions covering the range of approximately 0.4 to 4 mg/L of chloride, bromide and nitrate. Store working standards in tightly sealed polyethylene bottles. Prepare fresh working standards weekly.
15. Calibrate the ion chromatograph with at least six working standards covering the range of 0.4 to 4 mg/L of chloride, bromide and nitrate per sample by preparing a calibration graph of anion peak height (mm or μS [micro-siemens]) vs. concentration (mg/L).

16. Analyze working standards together with samples, reagent blanks and field blanks at a frequency of at least 1 per 20 samples (3 minimum of each).

MEASUREMENT:

17. Set the ion chromatograph to recommended eluent flow rate (e.g., 1.5 mL/min) and recommended pressure (e.g., 1.1×10^5 kPa), and other conditions as specified by the instrument manufacturer.
18. Inject a sample aliquot, e.g., 25- μ L, into the chromatograph, and measure the peak heights of the chloride, bromide and nitrate peaks (at retention times of approx. 5 min, 9 min and 12 min, respectively). If the peak height exceeds the linear calibration range, dilute with eluent, reanalyze and apply the appropriate dilution factor in calculations.

CALCULATIONS:

19. Calculate the mass concentration of each anion, C (mg/m³), in the air volume sampled, V (L):

$$C = \left\{ \frac{(C_1 \cdot V_1 \cdot F_d) - (C_0 \cdot V_0)}{V} \right\} \cdot F_c$$

where:

C_0 = mean concentration, in mg/L, of anion in the field blank test solutions;

C_1 = concentration, in mg/L, of anion in the sample test solution;

V = volume, in liters, of the air sample;

V_0 = volume, in mL, of the field blank test solutions;

V_1 = volume, in mL, of the sample test solutions

F_d = dilution factor for each sample test solution

F_c = conversion factor to convert from anion to acid concentration ($F_c = 1.0284$ for chloride, 1.0126 for bromide, and 1.0163 for nitrate)

EVALUATION OF METHOD:

On impregnated quartz fiber filters, greater than 95 % recovery of hydrochloric and nitric acid was found four weeks after sample collection, and no breakthrough was observed at sample loadings of up to 2.5 mg HCl or 5 mg HNO₃ [3,4,11]. Mean analytical recovery determined from the analysis of spiked filters has been found to be in the range of 97 to 100% for HBr, HCl and HNO₃ [3,11]. The component of the coefficient of variation of the method that arises from analytical variability, determined from the analysis of filters sampled at a dynamic test gas apparatus, was 0.8% to 1.3% for hydrogen chloride and 1.1% to 8.8% for nitric acid; and as determined from the analyses of spiked samples of hydrogen bromide, this value was 0.8% to 1.4% [3]. The method has been independently verified for all three acids, in accordance with applicable performance criteria [11,12]. An interlaboratory study with 5 participants found negligible biases and good agreement for hydrogen chloride and nitric acid at concentrations between 0.6 and 8 mg/m³ for HCl and 0.8 and 10 mg/m³ for HNO₃ [6]. The back-up data and user check reports are references 6 and 11, respectively.

REFERENCES:

- [1] ACGIH [2013]. TLVs and BEIs based on the documentation of the Threshold Limit Values for chemical substances and physical agents and Biological Exposure Indices. Cincinnati, Ohio: American Conference of Governmental Industrial Hygienists. [www.acgih.org]. [Data accessed April 2014.]
- [2] Institut für Arbeitsschutz der Deutschen Gesetzlichen Unfallversicherung [2013]. GESTIS database on international limit values for hazardous substances (German Social Accident Insurance). Sankt

- Augustin, FRG: [<http://www.dguv.de/ifa/GESTIS>]. Data accessed April 2014.
- [3] Breuer D, Gusbeth K [2007]. Anorganische säuren, flüchtig: bromwasserstoff, chlorwasserstoff, salpetersäure (Volatile inorganic acids: hydrobromic, hydrochloric, and nitric acids), IFA Working Folder, Sheet No. 6172. Bielefeld, FRG: Erich Schmidt Verlag.
- [4] ISO (International Organization for Standardization) [2007]. ISO 21438-2, Workplace atmospheres - Determination of inorganic acids by ion chromatography - Part 2: Volatile acids, except hydrofluoric acid (hydrochloric acid, hydrobromic acid and nitric acid). Geneva, Switzerland: International Organization for Standardization.
- [5] ISO (International Organization for Standardization) [1995]. ISO Guide 98: Guide to the expression of uncertainty in measurement. Geneva, Switzerland: International Organization for Standardization.
- [6] Howe A, Musgrove D, Breuer D, Gusbeth K, Moritz A, Demange M, Oury V, Rousset D, Dorotte M [2011]. Evaluation of sampling methods for measuring exposure to volatile inorganic acids in workplace air. Part 1: Sampling hydrochloric acid (HCl) and nitric acid (HNO₃) from a test gas atmosphere. *J Occup Environ Hyg.* 8:492-502.
- [7] NIOSH [1994]. Acids, inorganic: Method 7903. In: Eller PM, Cassinelli ME, eds. NIOSH Manual of analytical methods, 4th ed., Cincinnati, OH: U.S. Department of Health and Human Services, Center for Disease Control and Prevention, National Institute for Occupational Safety and Health, DHHS (NIOSH). Publication No. 94-113. [www.cdc.gov/niosh/nmam].
- [8] NIOSH [2005]. NIOSH Pocket guide to chemical hazards. Barsan ME, ed. Cincinnati, OH: US Department of Health and Human Services, Centers for Disease Control and Prevention, National Institute for Occupational Safety and Health, DHHS (NIOSH) Publication No. 2005-149.
- [9] Furr AK, ed. [1995] CRC Handbook of laboratory safety, 4th ed. Boca Raton, FL: CRC Press.
- [10] ASTM International [2010]. ASTM D4840: Standard guide for sampling chain of custody procedures. West Conshohocken, PA: ASTM International.
- [11] Breuer D [1997]. Volatile inorganic acids (HCl, HBr, HNO₃). In: Kettrup A, Greim H, eds. Analyses of hazardous substances in air (Deutsche Forschungsgemeinschaft). Vol. 6. Weinheim, FRG: Wiley-VCH. pp. 214-223.
- [12] Comité Européen de Normalisation (CEN) [2012]. EN 482, Workplace exposure — General requirements for the performance of procedures for the measurement of chemical agents. Brussels, Belgium: Comité Européen de Normalisation (CEN).

METHOD WRITTEN BY:

Dietmar Breuer, Dr. rer. nat., and Petra Heckmann, Institute for Occupational Safety and Health of the German Social Accident Insurances, Sankt Augustin, Germany; and Kevin Ashley, Ph.D., NIOSH/DART.

Disclaimer: Mention of any company or product does not constitute endorsement by NIOSH. In addition, citations to websites external to NIOSH do not constitute NIOSH endorsement of the sponsoring organizations or their programs or products. Furthermore, NIOSH is not responsible for the content of these websites. All web addresses referenced in this document were accessible as of the publication date.

TABLE 1. General Information

| Acid | MW | CAS Number | RTECS Number |
|------------------|-------|------------|--------------|
| HCl | 36.46 | 7647-01-0 | MW4025000 |
| HBr | 80.91 | 10035-10-6 | MW3850000 |
| HNO ₃ | 63.01 | 7697-37-2 | QU5775000 |

TABLE 2. Occupational Exposure Limits

| Acid | OSHA | NIOSH |
|------------------|--|--|
| HCl | C ^a 5 ppm, 7 mg/m ³ | C ^a 5 ppm, 7 mg/m ³ |
| HBr | 8 hr TWA ^b 3 ppm 10 mg/m ³ | C ^a 3 ppm, 10 mg/m ³ |
| HNO ₃ | 8 hr TWA ^b 2 ppm 5 mg/m ³ | TWA ^c 2 ppm 5 mg/m ³ STEL ^d 4 ppm 10 mg/m ³ |

- a Ceiling Limit
b Time-Weighted Average
c Up to 10 hr TWA in a 40 hr work week
d Short Term Exposure Limit

TABLE 3. Properties

| Acid | Physical State | MP (°C) | BP (°C) | Vapor Pressure (VP) |
|------------------|----------------|---------|---------|------------------------|
| HCl | gas | -114 | -84.9 | (38%) 28.3 kPa |
| | liquid | -- | 110 | (azeotropic, 20.2%) |
| HBr | gas | -86.9 | -66.8 | 2026.4 kPa |
| HNO ₃ | liquid | -42 | -- | (68% Nitric) 101.3 kPa |

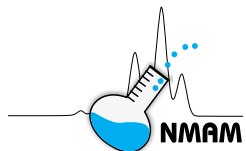

NON-VOLATILE ACIDS (Sulfuric Acid and Phosphoric Acid) 7908

| | | | |
|---------------------|-----------|----------------|------------------|
| Formulae: H_2SO_4 | MW: 98.08 | CAS: 7664-93-9 | RTECS: WS5600000 |
| H_3PO_4 | MW: 98.0 | CAS: 7664-38-2 | RTECS: TB6300000 |

METHOD: 7908, Issue 1 EVALUATION: FULL Issue 1: 10 May 2014

| | |
|--|---|
| <p><i>U.S. OELs</i> OSHA : 1 mg/m³ (H_2SO_4 & H_3PO_4) NIOSH: 1 mg/m³ (H_2SO_4 & H_3PO_4); STEL: 3 mg/m³ (H_3PO_4) <i>Other</i> OELs: [1,2]</p> | <p>PROPERTIES: H_2SO_4: Liquid, mp = 3.0 °C (98%); 10 °C (100%); bp = 338 °C (98%); 330 °C (100%); VP = < 0.0001 kPa @ 20 °C H_3PO_4: Solid (often used in an aqueous solution), mp = 42.4 °C; bp = 158 °C; vp = 0.0038 kPa @ 20 °C</p> |
|--|---|

SYNONYMS: H_2SO_4 : hydrogen sulfate, oil of vitriol; H_3PO_4 : ortho-phosphoric acid

| SAMPLING | MEASUREMENT |
|---|--|
| <p>SAMPLER: FILTER, 37-mm diameter quartz fiber; or polytetrafluoroethylene (PTFE), 0.45 µm pore size</p> <p>FLOW RATE: 1 to 5 L/min</p> <p>VOL-MIN: 15 L -MAX: 2000 L</p> <p>SHIPMENT: 4 °C</p> <p>SAMPLE STABILITY: Stable for 1 week at about 20 °C and at 4 °C thereafter to 28 days [3]</p> <p>BLANKS: 3 field blanks minimum per set</p> | <p>TECHNIQUE: ION CHROMATOGRAPHY (IC) with conductivity detection</p> <p>ANALYTES: Sulfate (SO_4^{2-}) ion, phosphate (PO_4^{3-}) ion</p> <p>EXTRACTION: Aqueous solution of sodium carbonate / sodium hydrogen carbonate</p> <p>INJECTION VOLUME: 50 µL</p> <p>ELUENT: 2.7 mM Na_2CO_3/0.3 mM $NaHCO_3$, flow rate 1.5 mL/min</p> <p>COLUMNS: Pre-column, anion-exchange column and suppressor column</p> |
| ACCURACY* | CALIBRATION |
| <p>RANGE STUDIED: 0.005 to 2.0 mg/sample</p> <p>BIAS*: Negligible [3]</p> <p>OVERALL PRECISION ($\hat{S}_{r,T}$): H_2SO_4 = 0.086; H_3PO_4 = 0.106</p> <p>EXPANDED UNCERTAINTY*: less than 23% for both H_2SO_4 and H_3PO_4 [6]</p> <p>* Accuracy calculations were determined using references 5 and 6 rather than the traditional NIOSH accuracy criteria.</p> | <p>RANGE: H_2SO_4: 0.2 mg/L to 8 mg/L; H_3PO_4: 0.8 mg/L to 8 mg/L [6]</p> <p>ESTIMATED LOD: H_2SO_4 = 0.002 mg/m³; H_3PO_4 = 0.003 mg/m³ (1 m³ air volume)[6]</p> <p>PRECISION (\bar{S}_r): H_2SO_4 = 0.043; H_3PO_4 = 0.032 [3,7]</p> |

APPLICABILITY: The working range for H_2SO_4 is (at least) 0.002 to 1.0 mg/sample, for H_3PO_4 is 0.004 to 1.0 mg/sample for a 420 Liter air sample [3,6].

INTERFERENCES: Particulate salts of sulfate or phosphate will give a positive interference.

OTHER METHODS: This procedure, which is consistent with ISO 21438-1 [6], replaces NIOSH 7903 [8] for the determination of sulfuric and phosphoric acid in workplace air samples by IC. The main advantage of NIOSH method 7908 is that it can allow for the collection of the inhalable fraction of sulfuric and phosphoric acid aerosols by means of the pre-filter (housed within an optional inhalable sampler.)

REAGENTS:

1. Water, deionized (DI), ≥ 18 M Ω -cm resistivity
2. Sodium carbonate (Na₂CO₃), anhydrous, American Chemical Society (ACS) analytical grade
3. Sodium hydrogen carbonate (NaHCO₃), ACS analytical grade
4. Extraction & eluent stock solution: 0.27 M Na₂CO₃ / 0.03 M NaHCO₃; dissolve 2.86 g Na₂CO₃ and 0.25 g NaHCO₃ in 25 mL of deionized water and swirl to mix. Then bring to 100 mL in a volumetric flask, stopper and mix thoroughly.
5. Extraction & eluent solution: 0.0027 M Na₂CO₃ / 0.0003 M NaHCO₃; transfer 10 mL of 0.27 M Na₂CO₃ / 0.03 M NaHCO₃ stock solution to a 1 L volumetric flask, dilute to the mark with deionized water, stopper and mix thoroughly.
6. Sulfate (SO₄²⁻) ion and phosphate (PO₄³⁻) ion standard solutions, each 1000 mg/L
7. Calibration stock solution, 100 mg/L (as the anion): Place 10 mL aliquots of sulfate and phosphate standard solution into a 100 mL volumetric flask, dilute to the mark and mix thoroughly.

*See Special Precautions

EQUIPMENT:

1. Sampler: filter, 37-mm diameter quartz fiber; or polytetrafluoroethylene (PTFE), 0.45 μ m pore size, in cassette filter holder manufactured from acid-resistant (chemically inert) material
NOTE: Quartz fiber filters should be binderless and heat-treated.
2. Personal sampling pump, 1 to 5 L/min, with flexible connecting tubing
3. Ion chromatograph, with pre-column (50 mm by 4.0 mm), anion-exchange column (200 mm by 4.0 mm), suppressor column (4 mm) and conductivity detector; and connected to data processing unit
4. Ultrasonic bath
5. Vessels, 10-mL, plastic (e.g., polypropylene), with screw caps
6. Volumetric flasks, 25- to 1000 mL
7. Pipets, 50 to 10000 μ L
8. Beakers, 25 to 100 mL
9. Water purification system, to prepare greater than or equal to 18 M Ω -cm resistivity deionized water
10. Bottles, polyethylene, 100 mL
11. Syringes, plastic, 5 mL
12. Syringe filter cartridges, with 0.8- μ m pore size polytetrafluoroethylene (PTFE) membrane filters
13. Micro-syringes, 50 μ L, with 60 mm x 0.6 mm needles
14. Tweezers, PTFE-coated
15. Auto-sampler vials, 2 mL capacity
16. Analytical balance, with capability of weighing to nearest 0.01 mg

SPECIAL PRECAUTIONS: Wear gloves, lab coat, and safety glasses while handling acids. All work should be performed with adequate ventilation for personnel and equipment. It is imperative that acid be added to water in order to avoid a violent exothermic reaction. There is risk of fire and explosion when phosphoric acid has contact with bases, combustible substances, oxidizing agents, reducing agents or water. Avoid physical contact since both sulfuric and phosphoric acid are both corrosive and irritants to eyes, skin, and the respiratory system. These are caustic materials and can react with metals to form flammable hydrogen gas. Do NOT mix with solutions containing bleach or ammonia [9,10].

SAMPLING, SAMPLE TRANSPORT AND STORAGE:

1. Calibrate each personal sampling pump with a representative sampler in-line.
2. Sample at an accurately known flow rate between 1 and 5 L/min for a total sample size of 15 to 1000 Liters. Avoid sampler overloading.
3. Immediately after sampling, remove the filter from the cassette with PTFE-coated tweezers and place it in a 10-mL screw-cap plastic vessel. With about 2 mL extraction solution (0.0027 M Na₂CO₃ / 0.0003 M NaHCO₃), rinse material from the inside surfaces of the

cassette into the vessel. Add additional extraction solution into the vessel until a final volume of 5 mL is reached.

4. Submit at least three field blanks for each set of samples collected per day. Handle these in the same way as the field samples; i.e., place each filter into a vessel, add 5 mL of eluent solution and ship it to the lab along with the remaining samples.
5. Refrigerate all samples that are to be stored overnight (or longer) prior to shipment to the laboratory. Ship all samples to the laboratory in accordance with established chain-of-custody procedures [11].
6. Refrigerate the samples (4 °C) immediately upon receipt at the lab until ready for analysis.
7. Analyze samples within 4 weeks of receipt.

SAMPLE PREPARATION:

8. Remove sample vessels from storage and bring them to room temperature.
9. Sonicate the samples in an ultrasonic bath for at least 15 minutes and allow to cool for at least 30 minutes.
10. Using 5-mL syringes, filter each sample extract solution through a PTFE filter into clean plastic vessels or into autosampler vials (if autosampler used).

CALIBRATION AND QUALITY CONTROL:

11. Through dilution of the calibration stock solution in eluent solution, prepare calibration working standard solutions covering the range of approximately 0.2 to 8 mg/L of sulfate and phosphate. Store working standards in tightly sealed polyethylene bottles. Prepare fresh working standards weekly.
12. Calibrate the ion chromatograph with at least six working standards covering the range of 0.2 to 8 mg/L of sulfate and phosphate ion per sample by preparing a calibration graph of anion peak height (mm or μS [micro siemens]) vs. concentration (mg/L).
13. Analyze working standards together with samples, reagent blanks and field blanks at a frequency of at least 1 per 20 samples (3 minimum of each).

MEASUREMENT:

14. Set the ion chromatograph to desired eluent flow rate, e.g., 1.5 mL/min, and column pressure, e.g., 1.1×10^5 kPa, and other conditions as specified by the instrument manufacturer.
15. Inject a sample aliquot, e.g., 50- μL , into the chromatograph, and measure the peak heights of the phosphate and sulfate peaks (at retention times of about 9 min and 11.6 min, respectively). If the peak height exceeds the linear calibration range, dilute with eluent, reanalyze and apply the appropriate dilution factor in calculations.

CALCULATIONS:

16. Calculate the mass concentration of each anion, C (mg/m³), in the air volume sampled, V (L):

$$C = \left\{ \frac{(C_1 * V_1 * F_d) - (C_0 * V_0)}{V} \right\} * F_c$$

where:

C_0 = mean concentration, in mg/L, of anion in the field blank test solutions;

C_1 = concentration, in mg/L, of anion in the sample test solution;

V_1 = volume, in liters, of the air sample;

V_0 = volume, in mL, of the field blank test solutions;

V_1 = volume, in mL, of the sample test solutions

F_d = dilution factor for each sample test solution

F_c = conversion factor to convert from anion to acid concentration:

$F_c = 1.021$ for sulfate; $F_c = 1.031$ for phosphate

EVALUATION OF METHOD:

Laboratory testing with generated atmospheres of sulfuric acid mist yielded a collection efficiency of greater than 95% over the range 0.5 to 10 mg/m³ of H₂SO₄ on 0.45 µm pore size PTFE filters [4]. Greater than 95% recovery of sulfuric acid and phosphoric acid was found four weeks after sample collection. On quartz fiber filters, 97 to 100% recovery of sulfuric acid was found four weeks after sample collection, and no breakthrough was observed at sample loadings of up to 1 mg [3]. Mean analytical recovery determined from the analysis of spiked quartz fiber filters has been found to be in the range of 97 to 100% for both acids [3,4]. The component of the coefficient of variation of the method that arises from analytical variability, determined from the analysis of spiked quartz fiber filters, was 0.7% to 3.2% for phosphoric acid and 0.5% to 2.6% for sulfuric acid [3]. An interlaboratory study with 26 participants found negligible biases and interlaboratory relative standard deviations of 12 to 15% for sulfuric acid and phosphoric acid concentrations between 0.05 and 1 mg/m³ [12]. The method has also been field tested for sulfuric acid measurements at sample volumes of up to nearly 2,000 Liters [13]. The analytical figures of merit for the method satisfy performance criteria specified in an applicable consensus standard [14]. The back-up data and user check reports are references 4 and 12 respectively.

REFERENCES:

- [1] ACGIH [2013]. TLVs and BEIs based on the documentation of the Threshold Limit Values for chemical substances and physical agents and Biological Exposure Indices. Cincinnati, Ohio: American Conference of Governmental Industrial Hygienists. [www.acgih.org]. [Data accessed April 2014.]
- [2] Institut für Arbeitsschutz der Deutschen Gesetzlichen Unfallversicherung [2013]. GESTIS database on international limit values for hazardous substances (German Social Accident Insurance). Sankt Augustin, FRG: [https://www.dguv.de/ifa/index-2.jsp]. [Data accessed April 2014.]
- [3] Breuer D [2002]. Inorganic acid mists (H₂SO₄, H₃PO₄). In: Kettrup A, Greim H, eds. Analyses of hazardous substances in air (Deutsche Forschungsgemeinschaft). Vol. 6. Weinheim, FRG: Wiley-VCH. pp. 67-78.
- [4] Breuer D [1999]. Measurement of vapor-aerosol mixtures. *J Environ Monit.* 1:299-305.
- [5] ISO (International Organization for Standardization) [1995]. ISO Guide 98: Guide to the expression of uncertainty in measurement. Geneva, Switzerland: ISO.
- [6] ISO [2007]. ISO 21438-1: Workplace atmospheres – Determination of inorganic ions by ion chromatography – Part 1: Non-volatile acids (sulfuric acid and phosphoric acid). Geneva, Switzerland: International Organization for Standardization (ISO).
- [7] Breuer D [2013]. Anorganische Säuren, partikulär: Phosphorsäure, Schwefelsäure (Inorganic acid mists: phosphoric acid, sulfuric acid), in IFA Working Folder, Sheet No. 6173. Berlin, FRG: Erich-Schmidt Verlag. ISBN 978-3-503-13084-9.
- [8] NIOSH [1994]. Acids, inorganic: Method 7903. In: Eller PM, Cassinelli ME, eds. NIOSH Manual of analytical methods, 4th ed., Cincinnati, OH: U.S. Department of Health and Human Services, Center for Disease Control and Prevention, National Institute for Occupational Safety and Health, DHHS (NIOSH). Publication No. 94-113. [www.cdc.gov/niosh/nmam.]
- [9] NIOSH [2005]. NIOSH Pocket guide to chemical hazards. Barsan ME, ed. Cincinnati, OH: US Department of Health and Human Services, Centers for Disease Control and Prevention, National Institute for Occupational Safety and Health, DHHS (NIOSH) Publication No. 2005-149.

- [10] Furr AK, ed. [1995] CRC Handbook of laboratory safety, 4th ed. Boca Raton, FL: CRC Press.
- [11] ASTM International [2010]. ASTM D4840: Standard guide for sampling chain of custody procedures. West Conshohocken, PA: ASTM International.
- [12] Breuer D, Howe A [2006]. Performance of methods for measurement of exposure to inorganic acids in workplace air. *J Environ Monit.* 8:120-126.
- [13] Breuer D, Heckmann P, Gusbeth K, Schwab G, Blaskowitz M, Moritz A [2012]. Sulfuric acid at workplaces – applicability of the new indicative occupational exposure limit value (IOELV) to thoracic particles. *J Environ Monit.* 14:440-445.
- [14] Comité Européen de Normalisation (CEN) [2012]. EN 482, Workplace exposure — General requirements for the performance of procedures for the measurement of chemical agents. Brussels, Belgium: Comité Européen de Normalisation (CEN).

METHOD WRITTEN BY:

Dietmar Breuer, Dr. rer. nat., Institute for Occupational Safety and Health of the German Social Accident Insurances, Sankt Augustin, Germany; and Kevin Ashley, Ph.D., NIOSH/DART

Disclaimer: Mention of any company or product does not constitute endorsement by NIOSH. In addition, citations to websites external to NIOSH do not constitute NIOSH endorsement of the sponsoring organizations or their programs or products. Furthermore, NIOSH is not responsible for the content of these websites. All web addresses referenced in this document were accessible as of the publication date.

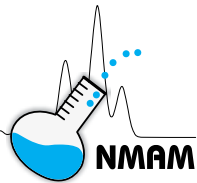

TOLUENE in Blood

8007

C₇H₈

MW: 92.14

CAS: 108-88-3

RTECS:XS5250000

METHOD: 8007, Issue 1

EVALUATION: FULL

Issue 1: 5 March 2013

NIOSH and OSHA: NA
Because data on exposure limits and guidelines may change over time, NIOSH recommends referring to the following sources for updated limits and guidelines [1,2].

PROPERTIES: Clear liquid; bp 110.6 °C; VP 28.4 mm Hg at 25 °C; d²⁰ 0.8669 g/mL.

BIOLOGICAL INDICATOR OF: Exposure to toluene

SYNONYMS: Methylbenzene, Phenylmethane, Toluol, Methylbenzol

| SAMPLING | | MEASUREMENT | |
|---|--|-------------------------------|--|
| SPECIMEN: | Blood (collected within 12 hours of last exposure) | TECHNIQUE: | HEADSPACE/GAS CHROMATOGRAPHY, FID |
| VOLUME: | Fill a 10-mL vacuum specimen tube as completely as possible (to reduce the amount of airspace) | ANALYTE: | Toluene |
| PRESERVATIVE: | Sodium citrate (light blue top) | HEADSPACE CONDITIONS: | Transfer Temp, 129 °C; Withdrawal, 0.80 min; Thermostat Time, 30 min; Needle, 120 °C; GC Cycle Time, 34 min; Sample Temp: 99 °C; Pressurize, 4.0 min; Inject, 0.40 min |
| SHIPMENT: | Insulated container with bagged refrigerant | INJECTION CONDITIONS: | Direct injection onto column for 0.4 min, then split flow for the remainder of the run at 130 mL/min |
| SAMPLE STABILITY: | Stable at least 30 days at 4 °C [3] | TEMPERATURE-INJECTION: | 129 °C |
| CONTROLS: | Collect and refrigerate immediately | -DETECTOR: | 250 °C |
| ACCURACY | | -COLUMN: | 50 °C (hold for 2 min); 50 to 220 °C @ 10 °C/min; 220 °C (hold for 5 min) |
| RANGE STUDIED: | 0.0208-5.76 µg/mL [3] | CARRIER GAS: | Helium, at 21 psi head pressure |
| ACCURACY: | <5% [3] | COLUMN: | Capillary, fused silica, 75-m x 0.53 mm, coated internally with 3.0 µm film 6% cyano- propylphenyl, 94% dimethylpoly-siloxane, bonded and cross-linked |
| BIAS: | 0.0006 | CALIBRATION: | Analyte in control blood; with isobutanol internal standard (IS) |
| OVERALL PRECISION (S_r): | 0.0157 [3] | Estimated LOD: | 0.006 µg/mL in whole blood [3] |
| SAMPLE STABILITY: | 99.0% (Day 30) [3] | | |

APPLICABILITY: Can be used in monitoring the exposure of workers and drug abusers for toluene.

INTERFERENCES: None identified. The chromatographic separation conditions may be adjusted to correct separation problems.

OTHER METHODS: NIOSH Method 8002 is a partially-evaluated, packed-column GC/FID method with lower accuracy and a higher detection limit. [4] The National Center for Environmental Health (NCEH)/CDC has a method for 31 volatile organic compounds in blood that includes toluene. This NCEH method is somewhat more complicated, comparable in accuracy, and ~1,000 times more sensitive. [5]

REAGENTS:

1. Whole blood*, citrate treated
2. Toluene* (reagent grade, >99.5%)
3. Isobutanol internal standard (IS) as a 20 mg/L solution in water*
4. Water, ASTM Type II
5. Helium, UHP or higher
6. Hydrogen, UHP or higher
7. Air, UHP or higher
8. Toluene calibration standards*
9. Ethylene glycol*

* See SPECIAL PRECAUTIONS

EQUIPMENT:

1. Gas chromatograph, with FID, column, and data collector (page 8007-1)
2. Headspace sampler, holds up to 40 vials and can thermostat up to 12 vials simultaneously for automated headspace analysis (Any instrument that can achieve the headspace settings specified on p. 8007-1 is acceptable)
3. Bagged refrigerant, and refrigerator
4. Adjustable pipette, 10-mL, tips 10-mL, plastic or serological
5. Headspace vials, 20-mL, with caps and septa
6. Micro-liter syringes, 10- μ L, 25- μ L, 100- μ L, 1-mL
7. Volumetric flasks, 10-mL, 25-mL, 1-L
8. Syringes, twist-on fitting (luer lock style or equivalent), 5-mL, and 20 gauge needles
9. Tubes, vacuum blood collection, 10-mL, citrate coated (light blue top)

SPECIAL PRECAUTIONS: Wear gloves, lab coat, and safety glasses while handling all chemicals and blood products. Disposable plastic, glass, and paper (pipet tips, gloves, etc.) that contact blood should be placed in a biohazard container. Contact with biological samples can have serious health consequences through exposure to hepatitis, HIV, and other diseases. All personnel collecting, handling, or analyzing samples should follow universal precautions [6] and comply with the OSHA bloodborne pathogens standard [7] which includes immunization for hepatitis B. Toluene is extremely flammable. All work should be performed in a fume hood.

SAMPLING:

1. Collect the blood by filling a 10-mL vacuum blood collection tube (light blue top, citrate) as completely as possible in order to keep the air space to a minimum. Be certain to invert the blood tube several (5-10) times to mix the anticoagulant.
NOTE: If desired, duplicate blood tubes could be drawn to allow for estimation of measurement precision, especially if collecting from numerous participants.
2. Immediately transfer the sample to a refrigerator or cooler (≤ 4 °C.)
3. Ship the sample vial in a well-insulated container equipped with blue ice or other cooling material.

SAMPLE PREPARATION:

4. Allow the blood sample to reach room temperature, then mix gently so as to not produce a froth by inverting the tubes 4 to 5 times.
5. Add 1.5 mL of the IS solution to a 20-mL headspace vial.
6. Extract 1.5 mL of sample from the vacuum vial using a 5-mL syringe with a twist-on fitting (luer lock style or equivalent) or micropipette and transfer the blood to a headspace vial.
7. Cap both sample and headspace vials immediately.
8. Mix the contents of each headspace vial thoroughly.

STOCK STANDARD PREPARATION:

9. Prepare a primary stock standard solution by diluting 20 μL of toluene to 50 mL with ethylene glycol (20 $\mu\text{L}/50\text{ mL} = 345.7\text{ }\mu\text{g}/\text{mL}$.) Store in a tightly capped glass container having little or no head space.
NOTE: Aliquots of toluene should be introduced below the ethylene glycol to prevent loss of toluene.
10. Prepare stock standards by diluting aliquots of the primary standards with ethylene glycol. Suggested levels: 34.6 $\mu\text{g}/\text{mL}$, 3.46 $\mu\text{g}/\text{mL}$, 0.346 $\mu\text{g}/\text{mL}$.

CALIBRATION AND QUALITY CONTROL:

11. Calibrate with at least five working standards in duplicate covering the concentration range of the samples.
 - a. Prepare each working standard by adding 1.5 mL of IS solution and 1.5 mL of blank blood to a headspace vial and cap the vial. Spike the mixture in the vial (through the septum using a micro-syringe) with a stock standard solution to the desired concentration of toluene and mix by shaking.
 - b. Prepare at least two blanks by repeating step a. but omitting the toluene spike.
 - c. Measure the peak areas of toluene and isobutanol in the chromatograms. Subtract the average toluene peak area of the blank from the toluene peak areas of the standards (see NOTE 1.) Divide the peak area of the blank-corrected toluene by the peak area from the isobutanol peak. Prepare a calibration curve of the peak area Std/area IS versus the toluene concentration of the standards.
NOTE 1: A trace amount of toluene may be present in the blood of some donors. These levels will vary depending upon environmental exposures. If the blanks show the presence of toluene the standards need to be blank corrected, or else the sample results will be biased low. Geometric means for the U.S. population as determined from the National Health and Nutrition Examination Survey may be useful for comparison. [8]
NOTE 2: It is also highly recommended that a reagent blank or blanks be included in the analysis. Atmospheric toluene in the lab may contribute errors to the measured values. A reagent blank using water, a blank headspace vial, or both of these options will show if the laboratory conditions are free from a quantifiable amount of toluene.
12. Prepare two levels of quality control (QC) samples by spiking toluene into whole blood. These levels could be at $\sim 10\text{ X LOQ}$ and 200 X LOQ , but could be adjusted to better suit the anticipated levels of the sample set. Unspiked samples of the blood used to prepare the QC samples should be analyzed to determine the blank level and the true target level. QC samples should be analyzed with every batch such that they constitute 10% of the sample batch.
13. QC values should be within $\pm 20\%$ of the spiked values. If not, the batch is considered out of control, the batch data discarded, and corrective actions should be taken before more samples are analyzed. Alternatively, if the method has a long history in the lab allowing enough data for control charts to be constructed, the control charts could serve as the in or out of control decision guide, which could be looser or stricter than the recommended 20%.

MEASUREMENT:

14. Set the gas chromatograph according to manufacturer's recommendations and to conditions given on page 8007-1.
15. Set the headspace sampler according to manufacturer's recommendations and to conditions given on page 8007-1.
16. Inject and analyze samples, standards, QC samples, and blanks.
17. Measure the peak area of both toluene and isobutanol in the chromatograms (do not subtract the blank from the samples). Divide the peak area of the toluene peak by the area from the isobutanol peak.

CALCULATIONS:

18. Determine the concentration ($\mu\text{g}/\text{mL}$) of the toluene in each sample of blood using the calibration curve obtained in step 11c.

EVALUATION OF METHOD:

This method was evaluated over the range specified on page 8007-1. These ranges, 0.0208 to 5.76 $\mu\text{g}/\text{mL}$, represent from 1 x LOQ to 300 x LOQ. Six replicates were analyzed at each level. The average recoveries at the various levels ranged from 97% to 106% for toluene. The LOD and LOQ were determined by preparing a series of duplicate standards. Each series was made up and analyzed on a different day. The resulting data was then fitted to a quadratic curve. The LOD and LOQ were estimated according to Burkart's Method. [9] A long-term storage study was carried out at the 10 x LOQ level. Citrated whole blood samples that were spiked with toluene were stored at 24 °C and 4 °C for 1, 4, and 7 days and for 7, 10, 21, and 30 days (respectively,) and then analyzed. Average recoveries were 96% at room temperature and 99% at 4 °C. Room temperature storage is not advised because if the sample clots before it is analyzed, the results will be compromised.

LIMITATION OF METHOD:

Concerning the use of isobutanol as an internal standard: While the boiling points of toluene and isobutanol are similar, their Henry's Law constants and thus their partitioning coefficients are quite different. This could lead to biases if there are differences in polarity in the samples or between the samples and the standards. This is one reason the calibration standards in this method are prepared using blood and not just solvent. An alternative approach could entail the use of an internal standard that partitions similarly to toluene, such as fully-deuterated toluene (toluene-d8). This would cause an increase in the cost of the method per sample (and would need to be validated by the end user), but is mentioned here as an option.

REFERENCES:

- [1] ACGIH [2014]. TLVs and BEIs based on the documentation of the Threshold Limit Values for chemical substances and physical agents and Biological Exposure Indices. Cincinnati, Ohio: American Conference of Governmental Industrial Hygienists. [www.acgih.org]. Date accessed: May 2014.
- [2] Commission for the Investigation of Health Hazards of Chemical Compounds in the Work Area [2014]. List of MAK and BAT values 2014; Maximum concentrations and biological tolerance values at the workplace. DFG: Deutsche Forschungsgemeinschaft, [http://onlinelibrary.wiley.com/book/10.1002/9783527682027]. Date accessed: January 2015.
- [3] Stone LC, Perkins JB [2003]. Backup data report for toluene in blood. DataChem Laboratories, Inc. under NIOSH contract CDC-200-2001-08000 (unpublished.)
- [4] NIOSH [1994]. Methyl ethyl ketone, ethanol and toluene in blood: Method 8002. In Eller PM, Cassinelli ME, eds. NIOSH Manual of Analytical Methods, 4th ed. Cincinnati, OH: U.S. Department of Health and Human Services, Centers for Disease Control and Prevention, National Institute for Occupational Safety and Health, DHHS(NIOSH) Publication no. 94-113.
- [5] Blount BC, Kobelski RJ, McElprang DO, Ashley DL, Morrow JC, Chambers DM, and Cardinali FL [2006]. Quantification of 31 volatile organic compounds in whole blood using solid-phase microextractions and gas chromatography-mass spectrometry. *J Chrom B* 832(2): 292-301.
- [6] NIOSH [2011]. Bloodborne infectious diseases: HIV/AIDS, Hepatitis B, Hepatitis C; universal precautions for preventing transmission of bloodborne infections [2011]. [www.cdc.gov/niosh/topics/bbp/universal.html]. Accessed September 2012.
- [7] OSHA [2012]. Bloodborne pathogens and needlestick prevention. [www.osha.gov/SLTC/bloodborne pathogens/index.html]. Accessed September 2012.

- [8] CDC [2012]. Fourth national report on human exposure to environmental chemicals, *updated tables, September 2012*. [www.cdc.gov/exposurereport/pdf/FourthReport_UpdatedTables_Sep2012.pdf]. Accessed October 2012.
- [9] Burkart JA [1986]. General procedures for limit of detection calculations in the industrial hygiene chemistry laboratory. *Appl. Ind. Hyg.* 1(3):153-155.

METHOD WRITTEN BY:

L. C. Stone and J. B. Perkins, DataChem Laboratories, Inc., Salt Lake City, Utah under NIOSH Contract CDC-200-2001-08000. Final editing by D. A. Shoemaker, NIOSH/DART.

Disclaimer: Mention of any company or product does not constitute endorsement by NIOSH. In addition, citations to websites external to NIOSH do not constitute NIOSH endorsement of the sponsoring organizations or their programs or products. Furthermore, NIOSH is not responsible for the content of these websites. All web addresses referenced in this document were accessible as of the publication date.



AW: Table 1

CAS: Table 2

RTECS: Table 2

METHOD: 8200, Issue 1

EVALUATION: FULL

Issue 1: 30 August 2018

OSHA: None
NIOSH: None
Other OELs: [1-3]

PROPERTIES: Table 1

ELEMENTS: calcium, copper, iron, potassium, magnesium, manganese, molybdenum, nickel, phosphorus, zinc

| SAMPLING | | MEASUREMENT | |
|---|---|--|---|
| SPECIMEN: | TISSUE | TECHNIQUE: | INDUCTIVELY-COUPLED PLASMA ATOMIC EMISSION SPECTROSCOPY (ICP-AES) |
| SPECIMEN SIZE: | dependent on tissue; 25-40 mg for nails | ANALYTE: | Table 1 |
| PRESERVATIVE: | none, if nails; freeze dried, if internal organ | DIGESTION ACID: | 4/1 (v/v) HNO ₃ /HClO ₄ |
| SHIPMENT: | routine, nails; see IATA regulations, freeze-dried tissue | FINAL SOLUTION: | 4%/1% (v/v) HNO ₃ /HClO ₄ ; 10 mL |
| SAMPLE STABILITY: | not established | WAVELENGTH: | varies with element; Table 2 |
| BLANKS: | collect at least 3 specimens from unexposed workers per set | CALIBRATION: | elements in 4%/1% (v/v) HNO ₃ /HClO ₄ |
| ACCURACY | | RANGE: | varies with element |
| RANGE STUDIED: | Tables 2 & 4 | ESTIMATED LOD: | Table 2 |
| BIAS: | Table 4 | PRECISION (\hat{S}_r): | Table 2 |
| OVERALL PRECISION (\hat{S}_{rT}): Table 4 | | | |
| ACCURACY*: Table 4 | | | |

*The definitions of precision and accuracy in this method are those utilized by the U.S. Food and Drug Administration [4].

APPLICABILITY: This method was developed to analyze nail samples from animals exposed to welding fume in laboratory-controlled inhalation studies. It is useful for monitoring nail tissues of workers exposed to several metals simultaneously. It may also be used for the analysis of freeze-dried tissue samples (liver, lungs, etc.) from laboratory studies. This is a simultaneous multielemental analysis, but is not compound-specific. Verify that the types of compounds in the samples are soluble with the dissolution procedure selected. Some compounds of these elements require special sample treatment. Other elements are amenable to this sample preparation and analysis, but due to availability of certified reference materials, only those elements listed have been validated.

INTERFERENCES: Spectral interferences are the primary interferences encountered in ICP-AES analysis. These are minimized by judicious wavelength selection, interelement correction factors and background correction [5,6].

OTHER METHODS: This method uses a measurement technique similar to that of Methods 7300 [7] (Elements; for air samples) and 8310 [8] (Metals in urine). The sample preparation is comparable to that in NIOSH 7300 [7].

REAGENTS:

1. Nitric acid, conc. (HNO₃) (Optima grade).*
2. Perchloric acid, conc. (HClO₄) (Optima grade).*
3. Digestion acid, 4:1 (v/v) HNO₃:HClO₄.* Mix 4 volumes conc. HNO₃ with one volume HClO₄.
4. Element standards, 100 µg/mL.
Commercially available or prepared per instrument manufacturer's recommendations.
5. Reference materials of known elemental composition.
6. Argon, as specified by ICP-AES manufacturer.
7. Deionized water, ASTM Type II [9] or equivalent.
8. Yttrium internal standard.

*See SPECIAL PRECAUTIONS.

EQUIPMENT:

1. Bottles, glass or polyethylene with polytetrafluoroethylene (PTFE)-lined caps, 20-mL.**
2. Regulator, two-stage, for argon.
3. Digestion vessel: Beakers, Griffin (50-mL) or Phillips (125-mL), PTFE or borosilicate glass** or digestion tubes (50-mL), polypropylene.
4. Watch glass covers.**
5. Hotplate or hot block, for use at 120 to 150 °C.
6. Volumetric flasks, 10-mL, 25-mL.**
7. Assorted volumetric pipettes, as needed.
8. Gloves, plastic, metal-free.
9. Scissors, surgical, stainless steel.

**All glassware should be detergent-washed, thoroughly rinsed with deionized water, soaked 12 h in conc. HNO₃ and thoroughly rinsed with deionized water.

SPECIAL PRECAUTIONS: All perchloric acid digestions must be carried out in a perchloric acid fume hood. When working with concentrated acids, wear protective clothing, safety goggles and gloves. All work should be performed with adequate ventilation for personnel and equipment. It is imperative that acid be added to water in order to avoid a violent exothermic reaction.

Samples of tissue collected from humans and animals pose a real health risk to laboratory workers who collect and handle these samples. These risks are primarily due to personal contact with infective biological samples and can have serious health consequences, such as infectious hepatitis, and other diseases. There is also some risk from the chemical content of these samples, but this risk is much less. Those who handle blood and tissue specimens should follow CDC Universal Precautions [10], wear protective gloves, and avoid aerosolization of the samples. Mouth pipetting, of course, must be avoided.

SAMPLING:

1. Collect tissue samples in pre-weighed screw top bottles or tubes.
NOTE 1: For nail samples, the tips of the nails should be gently trimmed using stainless steel surgical scissors. Clippings from each subject should be pooled.
NOTE 2: If the intent of the analysis is to determine internal elemental content, surface contamination should be avoided and nail samples may need to be cleaned of exogenously bound metals before collection and/or sample preparation.
NOTE 3: If shipping samples, follow current International Air Transport Association (IATA) regulations and use a certified IATA Dangerous Goods Shipper if necessary.
2. Weigh tissue samples.

SAMPLE PREPARATION:

3. Transfer tissue sample to digestion vessel. Rinse the sample container with a minimal amount of deionized water three times and transfer rinses to digestion vessel containing sample.
4. Add 5.0 mL digestion acid to each tissue sample. Cover beakers with watch glasses. Heat at 120-130 °C for 2 h.

NOTE: Start reagent blanks and QC samples at this step.

5. Increase hotplate temperature to 150 °C and heat until sample digestion is complete (no visible solid).

NOTE: A typical time frame for rodent nail samples is less than 1 week. If needed, additional acid may be added due to acid volume loss with heating.

6. Remove watch glass covers and reduce acid volume to near-dryness (ca. 0.5 mL).

7. Add 0.5 mL digestion acid.

8. After allowing to cool to room temperature, transfer the solutions quantitatively using deionized water to 10-mL flasks.

9. Dilute to volume using deionized water.

NOTE 1: The final sample volume may be held to different volumes based upon the analyst's needs.

Use of final volumes other than 10 mL will require an adjustment to the amount of digestion acid added in Step 7. The final sample should contain a minimum of 4%/1% HNO₃/HClO₄.

NOTE 2: If an internal standard will be used for the instrumental analysis, it should either be added

before sample dilution to final volume or introduced during sample uptake into the instrument.

CALIBRATION AND QUALITY CONTROL:

10. Calibrate the spectrometer according to manufacturer's recommendations.

NOTE: Typically, an acid blank, 0.1 µg/mL, and 1.0 µg/mL multielement calibration standards are used.

It is important that the calibration standards match the acid matrix and acid concentration of the samples. If an internal standard will be used for instrumental analysis, it must be added to the standards at the same concentration as in the samples. The following multielement combinations are chemically compatible in 4%/1% HNO₃/HClO₄:

- a. Al, As, Ba, Be, Ca, Cd, Co, Cr, Cu, Fe, La, In, Na
- b. Ag, K, Li, Mg, Mn, Ni, P, Pb, Se, Sr, Tl, V, Y, Zn, Sc
- c. Mo, Sb, Sn, Te, Ti, W, Zr

11. Analyze at least one calibration standard per ten samples to check that the instrument calibration is still valid. If control tissue samples are available, check recoveries with at least one media blank and two spiked media blanks per twenty samples. Media should be spiked with analytes of interest. If no control tissue samples are available, check recoveries using a reagent blank and certified reference materials or liquid spikes.

NOTE: Whenever possible, QA/QC samples should be prepared from certified reference materials in a matrix similar to the bulk material sampled. Liquid spiked samples are only surrogates for real world samples and QC data based upon certified samples are preferred.

MEASUREMENT:

12. Set the spectrometer to conditions specified by the manufacturer.
13. Analyze calibration standards and samples by ICP-AES in accordance with manufacturer recommendations.

NOTE: If the values for the samples are above the range of the standards, dilute the solutions (ensuring the samples remain acid matrix-matched to the calibration standards), reanalyze and apply the appropriate dilution factor in the calculations.

CALCULATIONS:

14. Obtain the solution concentration found for each element in the sample, C_s ($\mu\text{g/mL}$), and the average blank, C_b ($\mu\text{g/mL}$), from the measurement data.
15. According to the method of standardization, calculate the concentration, C ($\mu\text{g/g}$), of each element in the mass of sample taken, M (g). Use the final solution volumes of sample, V_s (mL) and blank, V_b (mL):

$$C = \frac{C_s V_s - C_b V_b}{M}, \mu\text{g/g}$$

EVALUATION OF METHOD:

Acceptable and unacceptable levels for elements within tissue samples have not been determined by this method. Iyengar [11] reports metals concentrations in tissues and body fluids. Lauwerys [12] discusses metals and can be consulted for guidance and interpretation. For tissue, trace element concentrations will vary with the tissue type or organ. Iyengar [11] reports metals concentrations for different tissues of non-occupationally exposed people.

This method was validated using control rat nails spiked with elements of interest and NIST SRM 1577C Bovine Liver. The results for the validated elements may be found in Tables 2 & 3, respectively. Mo was not included in the spiked control rodent nails, but was present in the SRM. The variability in the control rat nails, along with the concentration of elements in the SRM, limited the number of elements that could be quantitatively recovered. For example, the variability in the control nails was greater than the spiked amounts for Ca and P (Table 2) and the amounts present in the SRM for Ag, As, Ca, Cd, Cr, Ni, P, Sb, Sr, & V. Additionally, the concentrations of Co & Li detected in the SRM were less than the method LOQ. Acceptable amounts of Ca, Cu, Fe, K, Mg, Mn, Mo, P, and Zn were recovered at each level using the bovine liver SRM (Table 3).

While acceptable amounts were recovered using SRM 1577C for Ca, the large variability (with respect to the amount present in SRM 1577C) in the control nail samples for Ca calls into question the applicability of SRM 1577C for the validation of rat nail samples for Ca.

REFERENCES:

- [1] ACGIH [2018]. TLVs® and BEIs® based on the documentation of the Threshold Limit Values for chemical substances and physical agents and Biological Exposure Indices. Cincinnati, Ohio: American Conference of Governmental Industrial Hygienists.
- [2] Permanent Senate Commission for the Investigation of Health Hazards of Chemical Compounds in the Work Area [2016]. List of MAK and BAT values 2016; Maximum Concentrations and Biological Tolerance Values at the Workplace. Weinheim, Germany: Wiley-VCH Verlag GmbH & Co., <https://dx.doi.org/10.1002/9783527805983>.
- [3] Institute for Occupational Safety and Health of the German Social Accident Insurance (IFA) [2017]. GESTIS international limit values, <http://limitvalue.ifa.dguv.de/>.
- [4] US FDA [2001]. Guidance for industry: Bioanalytical method validation. Washington, DC: U.S. Food and Drug Administration, <http://www.fda.gov/downloads/Drugs/Guidances/ucm070107.pdf>.
- [5] Dean JA [1995]. Atomic spectroscopy. In: Analytical chemistry handbook; Section 7. New York, NY: McGraw-Hill.

-
- [6] Montaser A, Golightly DW, eds. [1992]. Inductively coupled plasmas in analytical atomic spectrometry. 2nd ed. Hoboken, NJ: John Wiley & Sons, Inc.
- [7] NIOSH [2003]. Method 7300, Elements by ICP (nitric/perchloric acid ashing). In: Schlecht PC, O'Connor PF, eds. NIOSH manual of analytical methods. 4th ed. Cincinnati, OH: U.S. Department of Health and Human Services, Centers for Disease Control and Prevention, National Institute for Occupational Safety and Health, DHHS (NIOSH) Publication No. 2003-154.
- [8] NIOSH [1994]. Method 8310, Metals in urine. In: Schlecht PC, O'Connor PF, eds. NIOSH manual of analytical methods. 4th ed. Cincinnati, OH: U.S. Department of Health and Human Services, Centers for Disease Control and Prevention, National Institute for Occupational Safety and Health, DHHS (NIOSH) Publication No. 94-113.
- [9] ASTM [2011]. ASTM D1193, Standard specification for reagent water. West Conshohocken, PA: ASTM International.
- [10] CDC [1988]. Perspectives in disease prevention and health promotion update: Universal precautions for prevention of transmission of human immunodeficiency virus, hepatitis b virus, and other bloodborne pathogens in health-care settings. MMWR 37(24):377-388.
- [11] Iyengar GV, Kollmer WE, Bowen HJM [1978]. The elemental composition of human tissues and body fluids: A compilation of values for adults. New York: Verlag Chemie Weinheim.
- [12] Lauwerys RR [1983]. Industrial chemical exposure: Guidelines for biological monitoring. Davis, CA: Biomedical Publications.
- [13] NIOSH [1995]. Guidelines for air sampling and analytical method development and evaluation. By Kennedy ER, Fischbach TJ, Song R, Eller PM, Shulman SA. Cincinnati, OH: U.S. Department of Health and Human Services, Centers for Disease Control and Prevention, National Institute for Occupational Safety and Health, DHHS (NIOSH) Publication No. 95-117.
- [14] NIOSH [2016]. Measurement uncertainty and NIOSH method accuracy: Chapter UA. In: Ashley K, O'Connor PF, eds. NIOSH manual of analytical methods. 5th ed. Cincinnati, OH: U.S. Department of Health and Human Services, Centers for Disease Control and Prevention, National Institute for Occupational Safety and Health, DHHS (NIOSH) Publication No. 2014-151, <https://www.cdc.gov/niosh/nmam/>.

METHOD WRITTEN BY:

Ronnee N. Andrews, Ph.D., NIOSH

Disclaimer: Mention of any company or product does not constitute endorsement by the National Institute for Occupational Safety and Health (NIOSH), Centers for Disease Control and Prevention (CDC). In addition, citations to websites external to NIOSH do not constitute NIOSH endorsement of the sponsoring organizations or their programs or products. Furthermore, NIOSH is not responsible for the content of these websites. All web addresses referenced in this document were accessible as of the publication date.

TABLE 1. PROPERTIES AND GENERAL INFORMATION

| Element (Symbol) | Atomic Weight | MP, °C | CAS # | RTECS |
|------------------|---------------|--------|-----------|-----------|
| Calcium (Ca) | 40.08 | 842 | 7440-70-2 | --- |
| Copper (Cu) | 63.54 | 1083 | 7440-50-8 | GL5325000 |
| Iron (Fe) | 55.85 | 1538 | 7439-89-6 | NO4565500 |
| Potassium (K) | 39.10 | 64 | 7440-09-7 | TS6460000 |
| Magnesium (Mg) | 24.31 | 651 | 7439-95-4 | OM2100000 |
| Manganese (Mn) | 54.94 | 1246 | 7439-96-5 | OO9275000 |
| Molybdenum (Mo) | 95.94 | 2623 | 7439-98-7 | QA4680000 |
| Nickel (Ni) | 58.71 | 1455 | 7440-02-0 | QR5950000 |
| Phosphorus (P) | 30.97 | 44 | 7723-14-0 | TH3500000 |
| Zinc (Zn) | 65.37 | 419 | 7440-66-6 | ZG8600000 |

TABLE 2. MEASUREMENT WAVELENGTHS (λ), DETECTION LIMITS (LOD) AND RECOVERY DATA FROM SPIKED CONTROL RODENT NAILS

| Element | λ^A , nm | LOD ^B , $\mu\text{g/g}$ | Spike concentration range, μg | Low level % Recovery (% RSD) ^C | Medium level % Recovery (% RSD) ^C | High level % Recovery (% RSD) ^C |
|---------|------------------|------------------------------------|--|---|--|--|
| Ca | 315.887 | 39. | 62.5-500 | N/A ^D | 38.7 (139) | 50.8 (44.6) |
| Cu | 324.754 | 6.0 | 6.25-50 | 99.1 (1.9) | 93.9 (2.6) | 95.3 (1.3) |
| Fe | 259.941 | 12. | 6.25-50 | 89.8 (3.7) | 89.7 (11.3) | 89.2 (1.8) |
| K | 766.491 | 34. | 93.8-750 | 112. (8.3) | 113. (6.1) | 124. (3.0) |
| Mg | 279.079 | 16. | 6.25-50 | 62.8 (50.3) | 81.0 (12.2) | 82.2 (4.9) |
| Mn | 257.611 | 1.4 | 1.25-10 | 88.2 (1.8) | 83.4 (2.9) | 86.0 (1.5) |
| Mo | 202.095 | 0.92 | - | - | - | - |
| Ni | 231.604 | 1.7 | 1.25-10 | 90.7 (1.9) | 85.2 (2.6) | 87.0 (1.6) |
| P | 178.287 | 2.3 | 6.25-50 | N/A | N/A | N/A |
| Zn | 213.856 | 20. | 18.8-150 | 96.9 (3.1) | 95.8 (2.6) | 91.0 (0.9) |

^ACommonly used wavelength; choose wavelength appropriate for your instrument settings [5,6]

^BLOD values calculated using the responses of 7 reagent blanks and corrected for average sample weight of 0.0393 g.

^CMean recovery & relative standard deviation for n=6, results corrected for average reagent blank and control nail response, % RSD calculated from % recovery

^DN/A indicates that the value could not be calculated; variability of elemental concentration in control nails greater than spiked amount for Ca & P

TABLE 3. RECOVERY DATA FROM BOVINE LIVER CERTIFIED REFERENCE MATERIAL

| Element | True value, µg/g | Low level % Recovery (%RSD) ^A | Medium level % Recovery (%RSD) ^A | High level % Recovery (%RSD) ^A |
|-----------|------------------|--|---|---|
| Ca | 131 | 102.3 (5.7) | 95.9 (4.5) | 90.5 (1.3) |
| Cu | 275.2 | 96.4 (1.9) | 94.1 (3.2) | 94.7 (1.4) |
| Fe | 197.94 | 85.6 (2.4) | 92.8 (3.6) | 98.7 (1.3) |
| K | 10230 | 105.9 (3.4) | 101.5 (3.4) | 98.7 (1.3) |
| Mg | 620 | 89.0 (2.2) | 85.0 (3.2) | 84.5 (1.4) |
| Mn | 10.46 | 84.7 (2.1) | 82.7 (3.5) | 83.0 (1.2) |
| Mo | 3.3 | 94.5 (2.0) | 94.7 (4.0) | 96.5 (1.3) |
| P | 11750 | 92.8 (3.1) | 89.4 (3.9) | 89.1 (1.5) |
| Zn | 181.1 | 94.9 (4.7) | 91.6 (4.0) | 91.9 (1.6) |

^AMean recovery & relative standard deviation for n=6

TABLE 4. ACCURACY, BIAS, AND PRECISION CALCULATED FROM BOVINE LIVER CERTIFIED REFERENCE MATERIAL

| Element | n ^A | Range, µg/sample | Bias | S _{rT} ^B | Accuracy, % |
|-----------|----------------|------------------|---------|------------------------------|-------------|
| Ca | 18 | 13.0 – 26.6 | -0.0956 | 0.00032 | 9.6 |
| Cu | 18 | 27.4 – 55.9 | -0.0493 | 0.00008 | 4.9 |
| Fe | 18 | 19.7 – 40.2 | -0.0649 | 0.00013 | 6.5 |
| K | 18 | 1020 – 2080 | 0.0622 | 0.00000 | 6.2 |
| Mg | 18 | 61.6 – 126 | -0.155 | 0.00003 | 15.5 |
| Mn | 18 | 1.04 – 2.13 | -0.165 | 0.00193 | 16.9 |
| Mo | 18 | 0.328 – 0.671 | -0.0474 | 0.00774 | 6.0 |
| P | 18 | 1170 – 2380 | -0.0950 | 0.00000 | 9.5 |
| Zn | 18 | 18.0 – 36.8 | -0.0712 | 0.00019 | 7.1 |

^An = total number of results reported for each element, ND results not included

^BS_{rT} = precision [13, 14]

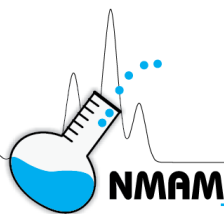

FLUORIDE in URINE

8308

F

MW: 19.00

CAS: 16984-48-8

RTECS: LM6290000

METHOD: 8308, Issue 3

EVALUATION: FULL

Issue 1: 15 February 1984

Issue 3: 14 March 2016

BIOLOGICAL INDICATOR OF: exposure to inorganic fluorides [1,2]

SYNONYMS: None

| SAMPLING | | MEASUREMENT | |
|---|--|--|--|
| SPECIMEN: | urine, pre- and post-shift | TECHNIQUE: | ION SELECTIVE ELECTRODE (ISE) |
| VOLUME: | 50 mL in chemically clean polyethylene bottles | ANALYTE: | fluoride ion (F ⁻) |
| PRESERVATIVE: | 0.2 g EDTA added to bottles before collection | DILUTION: | mix equal volumes of urine with TISAB |
| SHIPMENT: | in insulated containers using bagged refrigerant | CALIBRATION: | solutions of sodium fluoride in water |
| SAMPLE STABILITY: | 2 weeks @ 4 °C, longer if frozen | QUALITY CONTROL: | spiked urine pools; correct for creatinine content |
| CONTROLS: | collect 3 sets of specimens from unexposed workers (pre- and post-shift) | RANGE: | 1 to 100 mg/L urine |
| ACCURACY | | ESTIMATED LOD: | 0.1 mg/L urine |
| RANGE STUDIED: | not studied | RECOVERY: | 0.95 [3] |
| BIAS: | not determined | PRECISION (\bar{S}_r): | 0.04 |
| OVERALL PRECISION (\bar{S}_{rT}): | not determined | | |
| ACCURACY: | ± 23.6% | | |

APPLICABILITY: Any fluorine-containing substances that can be metabolized to fluoride (F⁻) can be monitored using this procedure. Inorganic compounds of fluoride can be absorbed by the body resulting in the excretion of fluoride ions as sodium fluoride. Dietary and domestic water sources of fluoride must be considered, as well as dental treatments.

INTERFERENCES: Hydroxide, the only positive interference, is eliminated by use of the buffer. Negative interferences from complexation of fluoride by cations, such as calcium, are minimized by EDTA preservative and the high ionic strength buffer.

OTHER METHODS: This method is P&CAM 114 [4] in a revised format. Other methods that have been used are those described in the NIOSH criteria documents on inorganic fluorides [1] and hydrogen fluoride [2].

REAGENTS:

1. Distilled or deionized water.
2. Sodium citrate tribasic dihydrate ($\text{Na}_3\text{C}_6\text{H}_3\text{O}_7 \cdot 2\text{H}_2\text{O}$), ACS reagent grade or better.
3. Ethylenediaminetetraacetic acid (EDTA) disodium salt, ACS reagent grade or better.
4. Acetic acid, glacial, ACS reagent grade or better.
5. Sodium chloride, ACS reagent grade or better.
6. Sodium hydroxide, 5 M. Dissolve 20 g NaOH in distilled water; dilute to 100 mL.
7. Sodium fluoride, ACS reagent grade or better.
8. Calibration stock solution, 100 $\mu\text{g F}^-/\text{mL}$. Dissolve 0.2211 g dry sodium fluoride in distilled water. Make 1000 mL solution.
9. Total ionic strength activity buffer (TISAB), pH 5. Add 57 mL glacial acetic acid, 58 g sodium chloride, and 0.30 g sodium citrate to a 1-L beaker containing 500 mL distilled water. Stir to dissolve. Place beaker in water bath for cooling. Slowly add 5 M sodium hydroxide until the pH is between 5.0 and 5.5. Cool to room temperature; dilute to 1 L with distilled water.
10. Fluoride in Urine Certified Reference Materials (CRMs).

EQUIPMENT:

1. Polyethylene bottles, 125-mL, wide-mouth.
2. Fluoride ion specific electrode (ISE), with reference electrode.
3. pH/millivolt meter, reading to ± 0.5 mV.
4. Stirrer, magnetic.
5. Stirring bars, PTFE-coated.
6. Beakers, plastic, 50-mL.
7. pH electrode.
8. Pipets, appropriate sizes for standards.
9. Volumetric flasks for standards.
10. Water bath.
11. Tissues, low-lint lab wipers.

SPECIAL PRECAUTIONS: Wear gloves, lab coat, and safety glasses while handling all chemicals and human urine products. Disposable plastic, glass, and paper (pipet tips, gloves, etc.) that contact urine should be placed in a biohazard container. Standard precautions should always be used when handling bodily fluids and/or extracts of bodily fluids [5]. Handle urine samples and urine extracts using proper gloves. Glacial acetic acid is flammable and corrosive and should be handled in a fume hood.

SAMPLING:

1. Collect pre- and post-shift spot urine samples in polyethylene bottles containing 0.2 g EDTA.
2. Ship samples in insulated container at about 4 °C using bagged refrigerant.

SAMPLE PREPARATION:

3. Perform a creatinine determination on an aliquot of the urine (e.g., [6]).

CALIBRATION AND QUALITY CONTROL:

4. Prepare at least five working standards in the range 0.1 to 100 $\mu\text{g F}^-/\text{mL}$ by appropriate dilutions of the calibration stock solution with distilled water.

5. Analyze a set of working standards together with the samples and blanks (steps 9 through 12) starting with the lowest concentration.
NOTE: Working standards, samples, and blanks must be analyzed under the same conditions, including temperature, for accurate results.
6. Prepare a semi-log calibration curve plotting millivolts on the linear scale (y-axis) and fluoride concentration, $\mu\text{g/mL}$, on the log scale (x-axis).
7. Maintain standardization by running a standard with every 10 specimens.
8. Run a spiked urine control specimen with every 10 specimens to maintain quality assurance.
NOTE: Urine used for spiked controls must be analyzed before use to determine background fluoride concentration.

MEASUREMENT:

9. Add 10 mL well-mixed urine and 10 mL TISAB to a 50-mL plastic beaker.
10. Place a small stirring bar into beaker and mix continuously on a magnetic stirrer at room temperature.
11. Immerse electrodes. Allow sample to mix for 2 to 3 min and then record millivolt reading.
12. Rinse electrodes and stirring bar thoroughly with distilled water and wipe dry with tissue before next sample analysis.

CALCULATIONS:

13. Convert the millivolt readings to fluoride concentration using the calibration curve from step 6.
14. Express fluoride concentration as mg F/g urinary creatinine.

GUIDES TO INTERPRETATION:

Urine concentrations of fluorides in normal non-occupationally exposed workers have been reported to range from 0.2 to 3.2 mg/L depending on dietary intake [7]. Pre-shift levels of less than 4 mg/g creatinine and post-shift levels of less than 7 mg/g creatinine appears to protect workers against bony fluorosis [8]. NIOSH has recommended that post-shift urine specimens should not exceed 7 mg/L (corrected to a specific gravity of 1.024) and pre-shift specimens should not exceed 4 mg/L (corrected to a specific gravity of 1.024) [1,2].

The Biological Exposure Indices (BEI) for fluoride (as of the date of this method's publication) are 2 mg/L prior to shift and 3 mg/L at end of shift [9]. This BEI changed in 2011.

EVALUATION OF METHOD

No formal method evaluation has been reported; however, Tusl [3] reported recoveries of added fluoride from 94 to 100%. Precision based on analysis of 25 specimens in triplicate is estimated to be better than $\bar{S}_r = 0.04$. This method employs standard methodology that has been shown to provide adequate performance data for decades. Additional evaluation data may be found in, but is not limited to, the following references [10-13].

REFERENCES:

- [1] NIOSH [1976]. NIOSH criteria for a recommended standard: occupational exposure to inorganic fluorides. Cincinnati, OH: U.S. Department of Health, Education, and Welfare, Center for Disease Control, National Institute for Occupational Safety and Health, DHEW (NIOSH) Publication No. 76-103.
- [2] NIOSH [1976]. NIOSH criteria for a recommended standard: occupational exposure to hydrogen fluoride. Cincinnati, OH: U.S. Department of Health, Education, and Welfare, Center for Disease Control, National Institute for Occupational Safety and Health, DHEW (NIOSH) Publication No. 76-143.

-
- [3] Tusi J [1970]. Direct determination of fluoride in human urine using fluoride electrode. *Clin Chim Acta* 27:216-218.
- [4] NIOSH [1977]. Fluoride in urine: P&CAM 114. In: Taylor DG, ed. NIOSH manual of analytical methods. 2nd ed., Vol 1. Cincinnati, OH: U.S. Department of Health, Education, and Welfare, Center for Disease Control, National Institute for Occupational Safety and Health, DHEW (NIOSH) Publication No. 77-157A.
- [5] CDC [2007]. 2007 Guidelines for isolation precautions: preventing transmission of infectious agents in healthcare settings [<http://www.cdc.gov/hicpac/2007IP/2007isolationprecautions.html>]. Date accessed: March 2016.
- [6] Tietz NW [1976]. *Fundamentals of clinical chemistry*. 2nd ed. Philadelphia, PA: W. B. Saunders Co., pp. 994-999.
- [7] Baselt RC [1980]. *Biological monitoring methods for industrial chemicals*. Davis, CA: Biomedical Publications, pp. 140-143.
- [8] Lauwreys RR [1983]. *Industrial chemical exposure: guidelines for biological monitoring*. Davis, CA: Biomedical Publications, pp. 26-27, 134.
- [9] ACGIH [2014]. *TLVs and BEIs based on the documentation of the Threshold Limit Values for chemical substances and physical agents and Biological Exposure Indices*. Cincinnati, Ohio: American Conference of Governmental Industrial Hygienists [www.acgih.org]. Date accessed: May 2014.
- [10] Singer L, Armstrong WD [1973]. Determination of fluoride in ultrafiltrates of sera. *Biochem Med* 8:415-422.
- [11] Chiba K, Tsunoda K, Haraguchi H, Fuwa K [1980]. Determination of fluoride in urine and blood serum by aluminum monofluoride molecular absorption spectrometry and with a fluoride ion selective electrode. *Anal Chem* 52:1582-1585.
- [12] Milde D, Nováková K, Čermáková I [2004]. Fluoride determination in urine with fluoride ion selective electrode: within laboratory method and sample storage optimization. *Acta Univ Palacki Olomu, Fac Rerum Nat, Chem* 43:104-109.
- [13] Singh B, Gaur S, Garg VK [2007]. Fluoride in drinking water and human urine in Southern Haryana, India. *J Hazard Mater* 144:147-151.

METHOD WRITTEN BY:

William P. Tolos, NIOSH.

Disclaimer: Mention of any company or product does not constitute endorsement by NIOSH. In addition, citations to websites external to NIOSH do not constitute NIOSH endorsement of the sponsoring organizations or their programs or products. Furthermore, NIOSH is not responsible for the content of these websites. All web addresses referenced in this document were accessible as of the publication date.



2,5-HEXANEDIONE in URINE

8318

CH₃COCH₂CH₂COCH₃

MW: 114.14

CAS: 110-13-4

RTECS: MO3150000

METHOD: 8318, Issue 1

EVALUATION: FULL

Issue 1: 15 August 2017

NIOSH and OSHA: NA

Because data on exposure limits and guidelines may change over time, NIOSH recommends referring to the following sources for updated limits and guidelines concerning 2,5-hexanedione as well as its use as a marker for other compounds [1-3].

PROPERTIES: Clear liquid; MP -5.5 °C; BP 191 °C; d²⁵ 0.973 g/mL; VP 0.43 mm Hg at 20 °C [4]

BIOLOGICAL INDICATOR OF: exposure to n-hexane and methyl n-butyl ketone

SYNONYMS: acetonyl acetone; diacetonyl; alpha, beta-diacetyethane; 1,2-diacetyethane; 2,5-diketohexane; 2,5-dioxohexane

| SAMPLING | MEASUREMENT |
|---|--|
| <p>SPECIMEN: two urine samples (one at the beginning of work week and one end of shift late in the work week)</p> <p>VOLUME: complete void stored in a polyethylene screw-cap bottle</p> <p>PRESERVATIVE: none</p> <p>SHIPMENT: refrigerated or frozen in well-insulated container</p> <p>SAMPLE</p> <p>STABILITY: stable 7 days @ 24 °C and at least 30 days @ 4 °C [5]</p> <p>CONTROLS: collect and pool urine from matched population of unexposed workers if possible then refrigerate immediately</p> | <p>TECHNIQUE: GAS CHROMATOGRAPHY, FLAME IONIZATION DETECTOR</p> <p>ANALYTE: 2,5-hexanedione (2,5-HD)</p> <p>TREATMENT: acid hydrolysis; dichloromethane extraction</p> <p>INJECTION VOLUME: 3µL; splitless for 0.7 min</p> <p>TEMPERATURE</p> <p>-INJECTION: 200 °C</p> <p>-DETECTOR: 250 °C</p> <p>-COLUMN: 45 °C (2 min hold); 45 to 60 °C @ 5 °C/min; 60 to 140 °C @ 10 °C/min; 140 to 220 °C @ 50 °C/min; 220 °C (5 min. hold); final hold time may be extended if necessary.</p> <p>CARRIER GAS: Helium, at 15 psi head pressure</p> <p>COLUMN: Capillary, fused silica, polyethylene glycol, 30 m x 0.32 mm ID, 0.5 µm film</p> <p>CALIBRATION: analyte in control urine; 2-methyl-3-heptanone or other appropriate internal standard</p> <p>ESTIMATED LOD: 0.2 mg/L in pooled urine [5]</p> |
| ACCURACY | |
| <p>RANGE STUDIED: 2.1 - 212 mg/L [5]</p> <p>BIAS: -0.0189</p> <p>OVERALL PRECISION ($\hat{S}_{r,T}$): 0.0235 [5]</p> <p>ACCURACY: ± 5.6%</p> <p>RECOVERY: 102% (Day 32) [5]</p> | |

APPLICABILITY: Can be used in monitoring the exposure of workers to n-hexane or methyl n-butyl ketone. This method measures "total" amount of 2,5-HD, not the "free" amount. See further discussion in Other Methods section.

INTERFERENCES: Other compounds besides n-hexane (e.g. methyl n-butyl ketone) can be metabolized into 2,5-HD. Acid hydrolysis can convert other metabolites (e.g. 4,5-dihydroxy-2-hexanone) into 2,5-HD, giving values higher than non-hydrolysis methods [6-8]. Coexposure to toluene and methyl ethyl ketone has been shown to inhibit n-hexane metabolism [9]. General population background levels of 2,5-HD vary by age and gender but average 0.4 mg/L [10].

OTHER METHODS: This method is based on the acid hydrolysis method of Iwata et al. [9], and Fedtke and Bolt [8] as described by Kawai et al. [11]. As discussed in greater detail in the Backup Data Report [5], this method uses an acid hydrolysis step to convert some of the intermediate metabolites to 2,5-HD, a measure of "total" 2,5-HD. A non-hydrolysis method, which measures the "free" 2,5-HD, was not investigated in this work. The "free" amount is associated with the Biological Exposure Index [1]. Other exposure values are more associated with the "total" amount found [2,3] and still others give the option of either approach [12]. Users should recognize the advantages and limitations of each approach when selecting a methodology. More on this can be found in the Evaluation of Method section and the backup data report [5].

REAGENTS:

1. Control urine, collected and pooled from unexposed workers*
2. 2,5-hexanedione stock solutions: Prepare by diluting the appropriate amounts of the pure analyte in methanol. Prepare working standards by diluting aliquots of the stock solution with pooled urine*
3. Extraction Solution: Dissolve 5 mg of the internal standard (2-methyl-3-heptanone) into dichloromethane; bring to 1.0 L total volume*
4. Hydrochloric acid (HCl), concentrated* (Trace metal grade or higher)
5. Methanol* (HPLC grade or higher)
6. Dichloromethane* (ACS reagent grade or higher)
7. Helium, purified
8. Hydrogen, prepurified
9. Air, filtered

* See SPECIAL PRECAUTIONS

EQUIPMENT:

1. Bottles, polyethylene screw-top, 125-mL
2. Gas chromatograph, with flame ionization detector, data system, and column (page 8318-1)
3. Vials, autosampler, glass, 2-mL, PTFE-lined crimp caps
4. Bagged refrigerant or dry ice
5. Pipettes, 5-, 2-, and 1-mL, plastic or serological
6. Heated water bath
7. Centrifuge
8. Culture tubes, glass, 13 x 100 mm with PTFE-lined screw caps
9. Syringes, 10-, 100-mL
10. Pipets, glass
11. pH meter
12. Magnetic stirrer
13. Volumetric flasks, glass, 1-L, 10-mL

SPECIAL PRECAUTIONS: Standard precautions should always be used when handling bodily fluids and/or extracts of bodily fluids [13]. Handle urine specimens and urine extracts using powder-free latex or nitrile gloves. All work should be performed in a fume hood since all chemicals are respiratory irritants and some may cause narcotic effects. Inhalation of large amounts of methanol or dichloromethane can cause unconsciousness and even death. 2,5-HD is a neurotoxin at high exposure levels. Methanol is a fire hazard and causes blindness or death if ingested. Hydrochloric acid is an extremely corrosive chemical capable of severe tissue damage.

SAMPLING:

1. Collect a complete void of urine in a 125-mL polyethylene bottle. Collect two urine specimens from each worker: one specimen at the beginning of the work week and one specimen at end of shift late in the work week.
2. Collect and pool urine from unexposed workers to be used for controls.
3. Tightly cap each bottle and ship refrigerated or frozen in a well-insulated container.
NOTE: Commercial shippers have special labeling requirements for packages containing biological samples and dry ice.

SAMPLE PREPARATION:

4. Allow urine specimens to reach room temperature.
NOTE: If desired, remove an aliquot of urine to determine creatinine levels (g/L urine).

5. Pipet 5.0 mL of urine into a 13 x 100 mm culture tube or other appropriate container.
6. Utilizing a magnetic stirrer, add concentrated HCl until the pH of the urine is within the desired range (0.5 to 1.0).
NOTE: An exact control of the sample's pH is critical for consistent and reproducible results [11].
7. Cap tube and heat in a water bath at 100 °C for 30 min.
8. Remove from water bath and allow to cool completely before proceeding.
9. Pipet 2 mL of the extraction solution, containing the internal standard, into the tube.
10. Cap and shake vigorously for 1 min. Allow the phases to separate. A centrifuge is recommended to aid in separation.
11. Remove a portion of the extraction solution (bottom layer) using a glass pipet and transfer it to a 2-mL glass GC autosampler vial. Cap and analyze.

CALIBRATION AND QUALITY CONTROL:

12. Calibrate daily with at least six working standards covering the concentration range of the specimens.
13. Prepare each working standard by diluting a known amount of 2,5-HD stock solution into enough pooled urine to make a total of 5.0 mL.
14. Prepare at least one pooled urine blank by transferring 5.0 mL of pooled urine (the same pooled urine used for creating the working standards) into a culture tube.
15. Prepare at least two levels of quality control (QC) spikes of 2,5-HD in pooled urine to be analyzed with each analysis batch. These levels should be at approximately 10 times the limit of quantitation (LOQ) and 200 times the LOQ, but can be adjusted to better suit the anticipated levels of the specimens. QC samples should be analyzed with every batch such that they constitute 10% of the specimen batch.
16. Process the 5 mL of each working standard and each pooled urine blank using the same procedure as for the specimens (steps 5 through 11).
17. Analyze the working standards, the pooled urine blanks, the QC samples, and the samples together.
18. QC values should normally be within $\pm 20\%$ of the spiked values. If not, the batch is considered out of control, the batch data discarded, and corrective actions taken before more specimens are analyzed.

MEASUREMENT:

19. Set gas chromatograph according to manufacturer's recommendations and to conditions given on page 8318-1. Typical retention times for the two compounds under these conditions are 4.7 min for the internal standard and 10.5 min for 2,5-HD.
20. Inject each of the standards, QC samples, samples, and blanks.
21. Measure peak area. Normalize analyte response by dividing the peak area of the analyte by the peak area of the internal standard on the same chromatogram.
22. Prepare a calibration graph by plotting, for each working standard, the normalized analyte response (peak area of analyte divided by the peak area of the internal standard on the same chromatogram) on the y-axis vs. mg of analyte/L of urine on the x-axis. The simplest model that adequately describes the data should be used but either a linear (mostly likely 1/x weighted because of the range of the calibration curve) or a quadratic model may be utilized in processing the analytical data. The standard curve should have a coefficient of determination (r^2) of equal to or greater than 0.98 to be acceptable for use. Furthermore, when each standard is plugged back into the calibration

equation, the value should be within $\pm 20\%$ of the expected. Acid hydrolysis can create detectable amounts of 2,5-HD in pooled urine blanks. Before plotting the calibration graph, subtract the normalized analyte response of the pooled urine blank from the normalized analyte response of each working standard.

CALCULATIONS:

23. Determine the 2,5-HD concentration, C_s (mg/L) in the urine specimen from the calibration graph created in step 16.
24. If desired, calculate the concentration of 2,5-HD in milligrams per gram of creatinine C (mg/g) in the urine specimen by dividing by the creatinine value C_r (g creatinine/L urine) obtained from the aliquot removed in step 4. Compare the results from before and after exposure. Also compare the results of the "exposed" group to that of the control group.

$$C = \frac{C_s}{C_r}$$

EVALUATION OF METHOD

This method was evaluated over the ranges specified on page 8318-1. These ranges represent from 3 times the LOQ to 300 times the LOQ. Seven replicates were analyzed at each level. The average recoveries at the various levels ranged from 97% to 103%. The limit of detection (LOD) and Limit of Quantification (LOQ) were determined by preparing in duplicate and analyzing a series of standards with the data fitted to a quadratic curve. The LOD and LOQ were estimated according to Burkart's Method [14]. A long-term storage study was carried out at the 10 x LOQ level. Pooled urine samples spiked with the analyte were stored at 4 °C for 1, 4, 7, 10, 21, or 32 days and then analyzed. All recoveries were nearly 100%. Spiked pooled urine samples were stable after 7 days at room temperature.

The issue of measuring "total" (the 2,5-HD determined after a hydrolysis step) versus "free" (the 2,5-HD determined without a hydrolysis step) is a contentious one among world bodies that develop biomonitoring guidelines. As previously stated, this method uses a hydrolysis step and was not evaluated without it. Therefore, it measures the "total" amount. NIOSH does not desire to step into the debate over which may be better, but just to offer this method as one way to assess exposure. Some brief summaries of the two approaches: "total" produces a larger number, requiring less sensitivity from the analytical methodology but is subject to higher variability resulting primarily from two sources: variability in hydrolysis procedure [11] and production of 2,5-HD from other metabolites in human urine that vary in concentration. The "free" approach gives a smaller number but tends to be more specific for n-hexane and methyl n-butyl ketone exposure as the other metabolites in urine do not interfere, so more sensitivity is required but background levels are greatly reduced.

REFERENCES:

- [1] AIHA [2014]. TLVs and BEIs based on the documentation of the Threshold Limit Values for chemical substances and physical agents and Biological Exposure Indices. Cincinnati, Ohio: American Conference of Governmental Industrial Hygienists, www.acgih.org.
- [2] Commission for the Investigation of Health Hazards of Chemical Compounds in the Work Area [2014]. List of MAK and BAT values 2014; Maximum concentrations and biological tolerance values at the workplace. DFG: Deutsche Forschungsgemeinschaft, <http://onlinelibrary.wiley.com/book/10.1002/9783527682027>.
- [3] SUVA (Swiss National Accident Insurance Fund) [2013]. Protection de la santé au poste de travail. Valeurs limites d'exposition aux postes de travail. 3rd Ed., <https://www.suva.ch/>
- [4] Sigma-Aldrich [2016]. 165131 ALDRICH, 2,5-Hexanedione, <http://www.sigmaaldrich.com/catalog/product/aldrich/165131>
- [5] Downs CC, Perkins JB [2002]. Back-up data report for 2,5-hexanedione method development. DataChem Laboratories, Inc. under NIOSH contracts CDC-200-95-2955 and CDC-200-2001-08000.
- [6] Fedtke N, Bolt HM [1986]. Detection of 2,5-hexanedione in the urine of persons not exposed to n-hexane. *Int Arch Occup Environ Health* 57: 143-148.
- [7] Fedtke N, Bolt HM [1987]. 4,5-Dihydroxy-2-hexanone: a new metabolite of n-hexane and of 2,5-hexanedione in rat urine. *Biomed Environ Mass Spectrom* 14:563-572.
- [8] Fedtke N, Bolt HM [1987]. The relevance of 4,5-dihydroxy-2-hexanone in the excretion kinetics of n-hexane metabolites in rat and man. *Arch Toxicol* 61:131-137.
- [9] Iwata M, Takeuchi Y, Hisanaga N, Ono Y [1983]. A study on biological monitoring of n-hexane exposure. *Int Arch Occup Environ Health* 51:253-260.
- [10] Tondel M, Murgia N, Persson B, Lindh J, Vrethem M, Fredrikson M [2011]. 2,5-Hexanedione in the general population: environmental exposure or endogenous production? *Epidemiology* 22(1):S34-S35.
- [11] Kawai T, Mizunuma K, Yasugi T, Uchida Y, Ikeda M [1990]. The method of choice for the determination of 2,5-hexanedione as an indicator of occupational exposure to n-hexane. *Int Arch Occup Environ Health* 62:403-408.
- [12] JSOH [2016]. Recommendation of occupational exposure limits (2016-2017). The Japan Society for Occupational Safety and Health. *Journal of Occupational Health* 58(5):489-518.

- [13] CDC [2007]. 2007 Guidelines for isolation precautions: preventing transmission of infectious agents in healthcare settings, <http://www.cdc.gov/hicpac/2007IP/2007isolationprecautions.html>.
- [14] Burkart JA [1986]. General procedures for limit of detection calculations in the industrial hygiene chemistry laboratory. *Appl Ind Hyg* 1(3):153-155.

METHOD WRITTEN BY:

Corey C. Downs and James B. Perkins, DataChem Laboratories, Inc., Salt Lake City, Utah under NIOSH Contracts CDC-200-95-2955 and CDC-200-2001-08000. Final editing by Dale A. Shoemaker, Ph.D., NIOSH/DART/CEMB.

Disclaimer: Mention of any company or product does not constitute endorsement by NIOSH. In addition, citations to websites external to NIOSH do not constitute NIOSH endorsement of the sponsoring organizations or their programs or products. Furthermore, NIOSH is not responsible for the content of these websites. All web addresses referenced in this document were accessible as of the publication date.

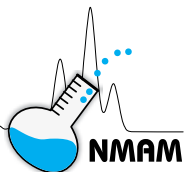

| | | | |
|--|-----------|--------------|------------------|
| (1) Acetone, CH ₃ COCH ₃ | MW: 58.08 | CAS: 67-64-1 | RTECS: AL3150000 |
| (2) Methyl ethyl ketone, CH ₃ COCH ₂ CH ₃ | MW: 72.11 | CAS: 78-93-3 | RTECS: EL6475000 |

METHOD: 8319, Issue 1 EVALUATION: FULL Issue 1: 28 October 2014

| | |
|--|--|
| <p>OSHA & NIOSH: N/A</p> <p>Because data on exposure limits and guidelines may change over time, NIOSH recommends referring to the following sources for updated limits and guidelines [1-4].</p> | <p>PROPERTIES: (1) bp 56.2 °C; d²⁰ 0.789 g/mL (2) bp 79.6 °C; d²⁰ 0.805 g/mL</p> <p>BIOLOGICAL INDICATOR OF: Exposure to (1) acetone (2) methyl ethyl ketone</p> |
|--|--|

SYNONYMS: (1) dimethyl ketone; 2-propanone; ketone propane; dimethyl formaldehyde; pyroacetic ether
(2) 2-butanone; MEK; butanone; methyl acetone; butan-2-one; oxobutane

| SAMPLING | MEASUREMENT |
|--|--|
| <p>SPECIMEN: Two urine samples (before and after exposure)</p> <p>VOLUME: Fill a 20-mL amber VOA vial leaving minimal headspace</p> <p>SHIPMENT: Ship in an insulated container with bagged refrigerant</p> <p>SAMPLE STABILITY: Stable at least 30 days at 4 °C [5]</p> <p>CONTROLS: Collect and pool urine from matched population of unexposed workers if possible, then refrigerate immediately</p> | <p>TECHNIQUE: GAS CHROMATOGRAPHY, FLAME IONIZATION DETECTOR, HEADSPACE</p> <p>ANALYTES: Acetone and methyl ethyl ketone</p> <p>INJECTION VOLUME: 500 µL or timed (see measurement section)</p> <p>TEMPERATURE -INJECTION: 180 °C -DETECTOR: 250 °C -COLUMN: 40 °C (4 min); 40 to 60 °C @ 3 °C/min; 60 to 220 °C @ 20 °C/min; 220 °C (2 min)</p> <p>CARRIER GAS: Helium, at 15 psi head pressure</p> <p>COLUMN: Capillary, fused silica, 6% cyanopropylphenyl, 94% dimethylpolysiloxane, 75 m x 0.53 mm ID, 3.0 µm film thickness</p> <p>CALIBRATION: Analyte in control urine; 2-pentanone or other appropriate internal standard</p> <p>ESTIMATED LOD: (1) 0.6 mg/L in pooled urine [5] (2) 0.6 mg/L in pooled urine [5]</p> |
| ACCURACY | |
| <p>RANGE STUDIED: (1) 2.1 - 606 mg/L [5] (2) 2.2 - 617 mg/L [5]</p> <p>ACCURACY: (1) ± 11.5%, (2) ± 15.0%</p> <p>BIAS: (1) -0.0444, (2) -0.0782</p> <p>OVERALL PRECISION (S_r): (1) 0.0468 [5], (2) 0.0507</p> <p>SAMPLE STABILITY: (1) 101% (Day 30) [5] (2) 105% (Day 30) [5]</p> | |

APPLICABILITY: This method can be used in the analysis of acetone and methyl ethyl ketone in urine specimens. These compounds may be found in the urine of individuals exposed to acetone and methyl ethyl ketone [6,7].

INTERFERENCES: Acetone is a metabolite of 2-propanol; MEK is a metabolite of 2-butanol. Exposure to 2-propanol or 2-butanol may result in increased acetone or MEK excretion, respectively [8,9]. Diabetes and fasting also produce elevated urinary acetone levels [10]. Ethanol reduces MEK metabolism and thus increases the MEK concentration in urine [11]. Gender differences and use of hormonal contraceptives have been shown to affect the metabolism and excretion of MEK [12].

OTHER METHODS: There are several commercially-available, direct-reading, dipstick-type tests that are non-specific for ketones in urine. These are often used in hospitals or by diabetic patients. The Deutsche Forschungsgemeinschaft (DFG, German Research Foundation) has published a headspace method for a variety of alcohols and ketones in urine and blood [13].

REAGENTS:

1. Pooled control urine collected from unexposed workers*
2. Acetone ($\geq 99\%$) and MEK ($\geq 99\%$) stock solution: Prepare by diluting the appropriate amounts of the pure analyte in water.* 750 μL in 10 mL gives ~ 60 mg/mL of each. Be certain to use the densities and purity factors when calculating the exact concentrations. [5]
3. Internal standard solution: Dilute 80 mg of 2-pentanone ($\geq 99\%$) in enough water to make 1.0 L (80 mg/L).^{*} Alternatively, 100 μL can be added to 1 L which gives roughly the same concentration.
4. Water, ASTM Type II [14]
5. Helium, purified
6. Hydrogen, prepurified
7. Air, filtered, prepurified

* See SPECIAL PRECAUTIONS

EQUIPMENT:

1. Bottles, polyethylene screw-top, 125-mL
2. Volatile organic analysis (VOA) vials, 20-mL, amber, polytetrafluoroethylene (PTFE) caps
3. Gas chromatograph, with flame ionization detector (FID), data system and column (p. 8319-1)
4. Headspace autosampler
5. Bagged refrigerant
6. Pipette, 10-mL, plastic or serological
7. Headspace vials, 20-mL, PTFE/Butyl septa, aluminum crimp cap
8. Microliter syringes, 10- μL , 100- μL , 1-mL
9. Volumetric flask, 10-mL

SPECIAL PRECAUTIONS: Wear gloves, lab coat, and safety glasses while handling all chemicals and human urine products. Disposable plastic, glass, and paper (pipet tips, gloves, etc.) that contact urine should be placed in a biohazard container. Standard precautions should always be used when handling bodily fluids and/or extracts of bodily fluids [15]. Handle urine samples and urine extracts using proper gloves. Acetone and MEK are highly flammable liquids. All work should be performed in a fume hood since both chemicals are respiratory irritants and may depress the central nervous system at high exposure levels.

SAMPLING:

1. Collect urine in a 125-mL polyethylene bottle or other suitable container. Collect at least two urine samples from each worker. Collect one sample before exposure and one sample after exposure.
NOTE: It is important to avoid contamination of the urine samples by making sure that samples are collected in a clean area away from the source(s) of exposure and under hygienic conditions (after washing hands.)
2. For each sample, immediately transfer from the 125-mL polyethylene bottle enough urine to fill a 20-mL amber VOA vial such that a minimal headspace is left. Cap the containers tightly. When the VOA vial is inverted no air bubbles should be present. Refrigerate after collection.
3. Collect and pool urine from unexposed workers to be used for controls. Refrigerate after collection.
4. Ship the VOA vials and pooled control urine in a refrigerated, well-insulated container. Store refrigerated upon receipt.

SAMPLE PREPARATION:

5. Allow urine to reach room temperature.
6. Pipet 10.0 mL of urine from the VOA vial into a 20-mL headspace vial.
7. Add 0.5 mL of the internal standard solution.
8. Cap vial immediately.

CALIBRATION AND QUALITY CONTROL:

9. Calibrate daily with at least six working standards covering the concentration range of the method (2 to 600 mg/L).

NOTE: If the range of concentrations of the samples is known (or expected), the calibration curve range can be adjusted accordingly.

- a. Prepare a diluted stock solution by pipetting 1 mL of the concentrated stock solution into a 10-mL volumetric flask and filling to the mark with pooled urine.
- b. Prepare each working standard by diluting a known amount of the diluted stock solution prepared in Step 9a into enough pooled urine to make a total of 10 mL.

NOTE: A second, more dilute stock solution in urine can be prepared, if desired, so that the lowest calibration standards are made using more easily-measured spiking volumes.

- c. Prepare at least one pooled urine blank by transferring 10 mL of pooled urine (the same pooled urine used for creating the working standards) into a vial.
 - d. Process the 10 mL of each working standard and each pooled urine blank using the same procedure as for the samples (steps 5 through 8).
 - e. Analyze the working standards, the pooled urine blanks, and the samples together. FIGURES 1 and 2 show representative chromatograms of blank and fortified urines.
 - f. Prepare a calibration graph by plotting, for each working standard, the normalized analyte response (peak area of analyte divided by the peak area of the internal standard on the same chromatogram) on the y-axis vs. μg of analyte/mL of urine on the x-axis. The simplest model that adequately describes the data should be used but either a linear (mostly likely 1/x weighted because of the range of the calibration curve) or a quadratic model may be utilized in processing the analytical data. Because humans can endogenously produce both acetone and methyl ethyl ketone, the compounds may be detected in the pooled urine blanks. Before plotting the calibration graph, subtract the normalized analyte response of the pooled urine blank from the normalized analyte response of each working standard. The standard curve should have a coefficient of determination (r^2) of equal to or greater than 0.98 to be acceptable for use. Furthermore, when each standard is substituted back into the calibration equation, the value should be within $\pm 20\%$ of the expected.
10. Prepare at least two levels of quality control (QC) samples by spiking both analytes in urine. These levels should be at approximately 10-fold the limit of quantitation (LOQ) and 200-fold the LOQ, but can be adjusted to better suit the anticipated levels of the sample set. Unspiked samples of the urine used to prepare the QC samples should be analyzed to determine the blank level and the true target level. QC samples should be analyzed with every batch such that they constitute 10% of the sample batch.
11. QC values should normally be within $\pm 20\%$ of the spiked values. If not, the batch is considered out of control, the batch data discarded, and corrective actions should be taken before more samples are analyzed.

MEASUREMENT:

12. Set gas chromatograph according to manufacturer's recommendations and to conditions given on p. 8319-1.
13. Set headspace autosampler according to manufacturer's recommendations and to the following conditions: (NOTE: different types of headspace samplers may require alternative conditions and some of these might not apply.)

a. Suggested conditions for a balanced-pressure type of headspace system:

| | | | |
|------------------|---------|--------------|----------|
| Transfer Temp: | 129 °C | Withdrawal: | 0.2 min |
| Thermostat Time: | 30 min | Needle Temp: | 120 °C |
| GC Cycle Time: | 28 min | Sample Temp: | 80 °C |
| Pressurize: | 1.0 min | Inject: | 0.08 min |

b. Suggested conditions for a syringe-injection type of headspace system:

| | | | |
|------------------|---------|-------------------|------------|
| Incubation Temp: | 95 °C | Injection volume: | 500 µL |
| Incubation Time: | 15 min | Fill speed: | 120 µL/sec |
| Agitation speed: | 250 rpm | Delay: | 5 sec |
| Run time: | 26 min | Injection speed: | 300 µL/sec |
| Syringe Temp: | 95 °C | Delay: | 500 msec |

14. Measure peak area. Normalize the analyte response by dividing the peak area of the analyte by the peak area of the internal standard on the same chromatogram for each working standard, sample, and pooled urine blank.

CALCULATIONS:

15. Determine both the acetone and MEK concentrations (mg/L) in the urine sample from the calibration graph prepared in Step 9f.

EVALUATION OF METHOD:

This method was evaluated over the ranges of the two analytes specified on p. 8319-1. These ranges represent from 1 x LOQ to 300 x LOQ. Six to seven replicates were analyzed at each level. The average recoveries at the various levels ranged from 94% to 106% for acetone and 85% to 98% for MEK. The LOD and LOQ were determined by preparing and analyzing a series of standards in duplicate with the data fitted to a quadratic curve. The LOD and LOQ were estimated according to Burkart's Method [16]. A long-term storage study was carried out at the 10 x LOQ level. Pooled urine samples spiked with the analytes were stored at 4 °C for 1, 4, 7, 10, 21, or 30 days and then analyzed. All recoveries were nearly 100%. When stored at room temperature, a significant reduction in analyte recovery was observed after 7 days [5].

REFERENCES:

- [1] ACGIH [2013]. TLVs® and BEIs® based on the documentation of the Threshold Limit Values for chemical substances and physical agents and Biological Exposure Indices. Cincinnati, Ohio: American Conference of Governmental Industrial Hygienists. www.acgih.org [Date accessed: August 2014.]
- [2] Commission for the Investigation of Health Hazards of Chemical Compounds in the Work Area [2013]. List of MAK and BAT values 2013; Maximum concentrations and biological tolerance values at the workplace. DFG: Deutsche Forschungsgemeinschaft, Wiley-VCH Verlag GmbH & Co. www.dfg.de/en/dfg_profile/publications/senate_commissions/index.html#micro7535782 [Date accessed: August 2014.]
- [3] SUVA (Swiss National Accident Insurance Fund) [2013]. Protection de la santé au poste de travail. Valeurs limites d'exposition aux postes de travail. <https://www.suva.ch/> [Date accessed: August 2014.]
- [4] Institut für Arbeitsschutz der Deutschen Gesetzlichen Unfallversicherung (IFA). <https://www.dguv.de/ifa/index-2.jsp> [Date accessed: August 2014.]

- [5] Downs CC, Perkins JB [2002]. Back-up data report for acetone and methyl ethyl ketone method development. DataChem Laboratories, Inc. under NIOSH contracts CDC-200-95-2955 and CDC-200-2001-08000.
- [6] Pezzagno G, Imbriani M, Ghittori S, Capodaglio E, Huang J [1986]. Urinary elimination of acetone in experimental and occupational exposure. *Scand J Work Environ Health* 12:603-608.
- [7] Perbellini L, Brugnone F, Mozzo P, Cocheo V, Caretta D [1984]. Methyl ethyl ketone exposure in industrial workers. Uptake and kinetics. *Int Arch Occup Environ Health* 54:73-81.
- [8] Kawai T, Yasugi T, Horiguchi S, Uchida Y, Iwami O, Iguchi H, Inoue O, Watanabe T, Nakatsuka H, Ikeda M [1990]. Biological monitoring of occupational exposure to isopropyl alcohol vapor by urinalysis for acetone. *Int Arch Occup Environ Health* 62:409-413.
- [9] Williams RT [1950]. Detoxication mechanisms: the metabolism and detoxication of drugs, toxic substances and other organic compounds. Chapman & Hall Ltd., London p. 66.
- [10] Bales JR, Bell JD, Nicholson JK, Sadler PJ [1986]. HNMR Studies of urine during fasting: excretion of ketone bodies and acetylcarnitine. *Magn Reson Med* 3:849-856.
- [11] Liira J, Riihimaki V, Engstrom K [1990]. Effects of ethanol on the kinetics of inhaled methyl ethyl ketone in man. *Br J Ind Med* 47:325-330.
- [12] Tomicic C, Berode M, Oppliger A, Castella V, Leyvraz F, Praz-Christinaz S-M, Danuser B [2011]. Sex differences in urinary levels of several biological indicators of exposure: A human volunteer study. *Toxicol Lett* 202:218-225.
- [13] Angerer J, Gundel J [2012]. Alcohols and Ketones [Biomonitoring Methods, 1996]. The MAK Collection for Occupational Health and Safety. pp. 1-33.
- [14] ASTM [2011]. ASTM Standard D1193, Standard specification for reagent water. ASTM International, West Conshohocken, PA. DOI 10.1520/D1193-06R11.
- [15] CDC [2007]. 2007 Guidelines for isolation precautions: Preventing transmission of infectious agents in healthcare settings. <http://www.cdc.gov/hicpac/2007IP/2007isolationprecautions.html>. [Date accessed: April 2013.]
- [16] Burkart JA [1986]. General procedures for limit of detection calculations in the industrial hygiene chemistry laboratory. *Appl Ind Hyg* 1(3):153-155.

METHOD WRITTEN BY:

Corey C. Downs and James B. Perkins, DataChem Laboratories, Inc., Salt Lake City, Utah under NIOSH Contracts CDC-200-95-2955 and CDC-200-2001-08000. Final editing by Dale A. Shoemaker, Ph.D., NIOSH/DART.

Disclaimer: Mention of any company or product does not constitute endorsement by NIOSH. In addition, citations to websites external to NIOSH do not constitute NIOSH endorsement of the sponsoring organizations or their programs or products. Furthermore, NIOSH is not responsible for the content of these websites. All web addresses referenced in this document were accessible as of the publication date.

FIGURE 1. Representative overlaid chromatograms from a high and low urine standard and urine blanks with and without internal standard (IS), full-scale

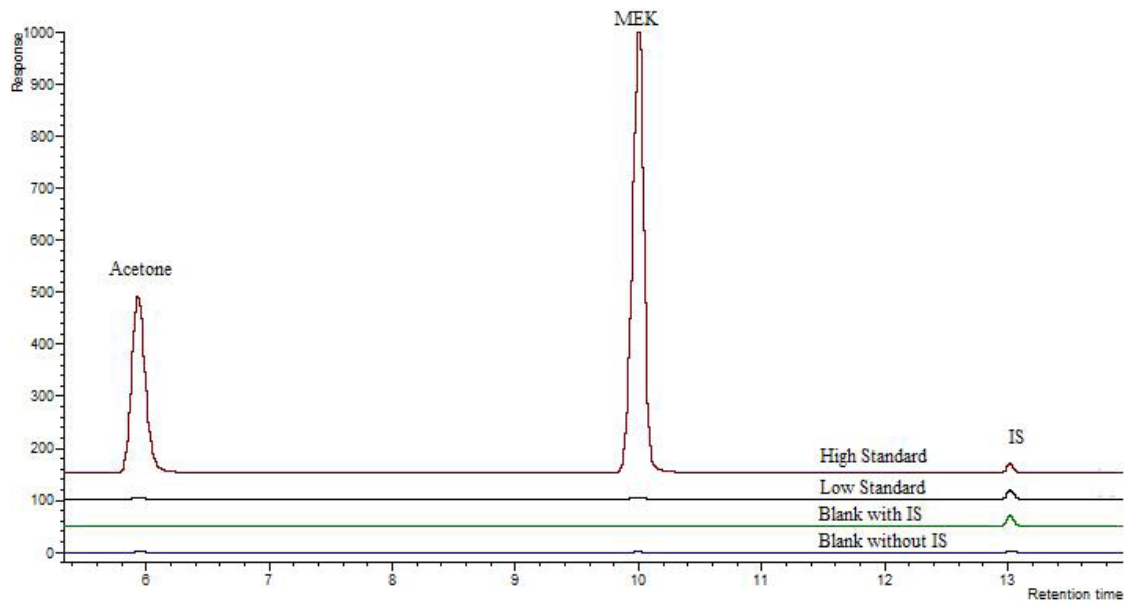
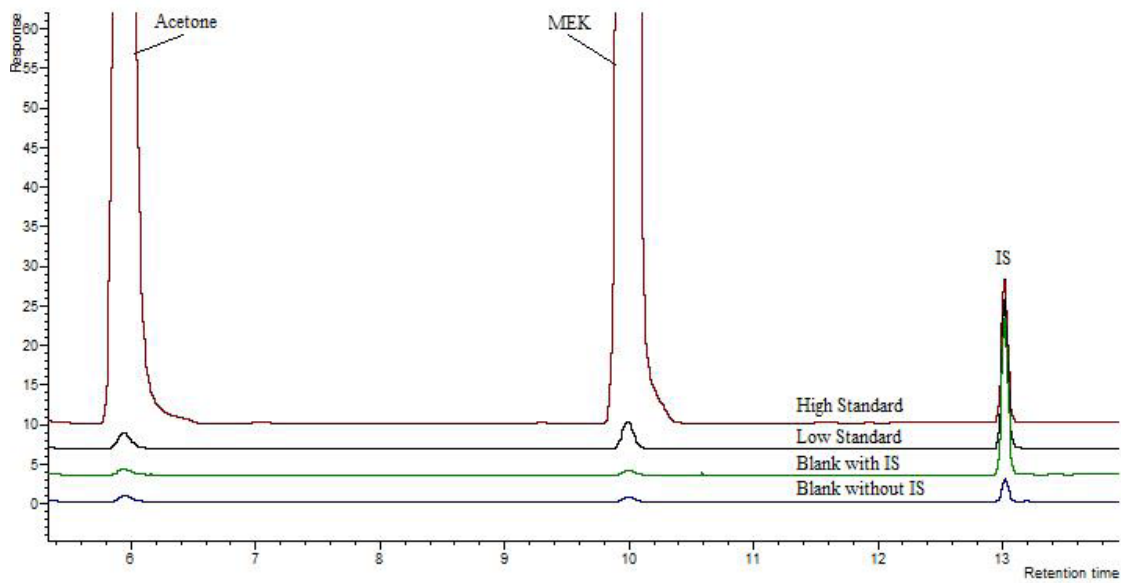

FIGURE 2. Representative overlaid chromatograms from a high and low urine standard and urine blanks with and without internal standard (IS), reduced-scale





BUTYLTIN TRICHLORIDE in Urine

8320

Formula: $C_4H_9Cl_3Sn$ MW: 282.18 CAS: 1118-46-3 RTECS: WH6780000

METHOD: 8320, Issue 1

EVALUATION: FULL

Issue 1: 10 January 2019

OSHA: N/A
NIOSH REL: N/A
OTHER OELs: Because exposure limits and guidelines may change over time, NIOSH recommends references [1-3] for updated limits and guidelines.

PROPERTIES: Colorless liquid; MP -63 °C; BP 93 °C @ 10 mmHg; Density - 1.693 g/mL @ 25 °C; VP 0.083 mmHg @ 20 °C [4]

SYNONYMS: butyltrichlorotin, butyltrichlorostannane, monobutyltin trichloride (MBTC)

| SAMPLING | | MEASUREMENT | |
|--|--|--|---|
| SPECIMEN: | Spot urine specimens (before and after exposure; end of shift or end of work week) [5] | TECHNIQUE: | GAS CHROMATOGRAPHY/MASS SPECTROMETRY-SELECTED ION MONITORING (GC/MS-SIM) |
| VOLUME: | 15 mL minimum | ANALYTE: | Derivative of butyltin trichloride: butyltriethyltin |
| PRESERVATIVE: | None | EXTRACTION: | Liquid-liquid extraction |
| SHIPMENT: | Freeze urine: ship frozen in an insulated container | DERIVATIZATION: | Grignard reaction with ethylmagnesium bromide |
| SAMPLE STABILITY: | Stable at least 300 days at -20 °C [6] | INJECTION VOLUME: | 2 µL |
| ACCURACY [6,7] | | TEMPERATURE: | |
| RANGE STUDIED: | 0.12-58 µg/5-mL sample | INJECTION: | 230 °C splitless for 0.75 min |
| BIAS: | 0.063 | DETECTOR: | 285 °C |
| OVERALL PRECISION ($\hat{S}_{r,T}$): | 0.041 | OVEN: | 75 °C (1 min); 75 °C to 225 °C @ 12 °C/min; hold 5 min |
| ACCURACY: | ± 13.0% | MASS SELECTIVE DETECTOR PARAMETERS: | |
| | | SIM IONS (<i>m/z</i>): | 178.9, 234.9 |
| | | DWELL TIME: | 200 msec per <i>m/z</i> |
| | | CARRIER GAS: | Helium at 1.3 mL/min |
| | | COLUMN: | Capillary, fused silica, phenyl arylene polymer virtually equivalent to (5% phenyl)-methylpolysiloxane (30 m x 0.32 mm ID, 0.5 µm film) |
| | | CALIBRATION: | Spikes of known concentrations prepared in pooled urine |
| | | ESTIMATED LOD: | 0.01 µg/5-mL sample [6] |

APPLICABILITY: This method can be used for the Determination of butyltin trichloride in urine samples. It may also be useful for other butyltin chloride compounds. See Evaluation of Method section for more information.

INTERFERENCES: Because of the separation and mass-selective capabilities of GC/MS, interferences are not anticipated to have any impact on the analysis.

OTHER METHODS: None

REAGENTS:

1. Butyltin trichloride, $\geq 95\%$ purity
2. Ethylmagnesium bromide, 1.0 M solution in tetrahydrofuran
3. Helium, UHP or Grade 5 (99.999%) or better
4. Sulfuric acid, 1 M: Dilute 5.6 mL conc. sulfuric acid to 100 mL deionized water
5. Citric acid/sodium citrate buffer (~pH 2.3): Dissolve 20.554 g citric acid monohydrate and 0.652 g sodium citrate dihydrate in 1 L deionized water
6. Toluene, ACS reagent grade or better
7. Tropolone extraction solution: 0.1% in toluene: Dissolve 100 mg tropolone (2-hydroxy-2, 4, 6-cycloheptatrienone, CAS# [533-75-5]) in 100 mL toluene
8. Alumina, acidic, Brockman activity I, 80-200 mesh
9. Sodium sulfate, granular, anhydrous; reagent grade or better

*See SPECIAL PRECAUTIONS.

EQUIPMENT:

1. Centrifuge tubes, 15-mL polypropylene with screw caps
2. Centrifuge, capable of at least 2400 RPM
3. Pipettes, Pasteur, 14.6 cm (5 $\frac{3}{4}$ ")
4. Culture tubes, glass, ~8-mL (13 mm x 100 mm), screw top with PTFE-lined caps
5. GC-MS capable of selected ion monitoring, column, autosampler and data collection system (p. 8320-1)
6. Microliter syringes
7. Volumetric flasks, glass, 5-mL
8. Pipettor, adjustable from 1-5 mL
9. Vortex mixer
10. Tumbler for centrifuge tubes, approximately 20 RPM
11. Bottles, polyethylene, 30- or 125-mL
12. Glass wool

SPECIAL PRECAUTIONS: Wear gloves, lab coat, and safety glasses while handling all chemicals and human urine products. Disposable plastic, glass, and paper (pipette tips, gloves, etc.) that contact urine should be placed in a biohazard bag. Standard precautions should always be used when handling bodily fluids and/or extracts of bodily fluids [8]. Handle urine samples and urine extracts using proper gloves. All work should be performed in a fume hood.

SAMPLING:

1. Collect urine in a 30-mL or 125-mL polyethylene bottle or other appropriate container.
NOTE: Collect two urine specimens for each worker, one prior to exposure and one after exposure. The NIOSH Health Hazard Evaluation found no significant difference between end of shift and end of work week [5]. Also, collect and pool urine from unexposed subjects for use as a standard and quality control sample matrix.
2. Freeze the urine (-20 °C or lower) and ship frozen in an insulated container.

SAMPLE PREPARATION:

3. Allow urine to reach room temperature and mix thoroughly.
4. Place 5 mL of the urine specimen in a 15-mL polypropylene centrifuge tube using a pipettor.
5. To the urine specimen, add:
 - a. 3 mL of ~pH 2.3 citric acid/sodium citrate buffer
 - b. about 350 mg anhydrous sodium sulfate (to break up emulsions)
 - c. 1.5 mL 0.1% tropolone in toluene solution
6. Cap and tumble for one hour at ~20 RPM.
7. Centrifuge for at least 10 min at 2400 RPM (1050 G).
8. Transfer the upper toluene layer to an 8-mL glass culture tube with a PTFE-lined cap using a Pasteur pipette.
9. Repeat steps 5c through 8 and combine the extracts.
10. Add about 350 mg anhydrous sodium sulfate to the combined extracts to remove any of the aqueous phase that may have been inadvertently transferred.
11. Decant the dried sample from step 10 into a second 8-mL glass culture tube with a PTFE-lined cap.
12. Rinse the sodium sulfate residue in the first tube twice with a small (~300 μ L) quantity of toluene which is then combined with the dried extract in the second tube.
13. Add 250 μ L of the ethylmagnesium bromide solution to the extract, mix, and allow the mixture to react for 15-20 minutes.
14. Add 1 mL of 1 M sulfuric acid (to react with the remaining ethylmagnesium bromide) and vortex the tube for approximately 30 seconds.
15. Prepare a clean-up column in a 14.6 cm disposable Pasteur pipette by adding, in order, 1) a glass wool plug, 2) alumina, acidic, Brockmann activity I, 80-200 mesh, enough to form a column of approximately 1 cm, and 3) ~100 mg of anhydrous sodium sulfate.
16. After the layers separate, elute the top toluene layer through this clean-up column.
17. Collect the eluate in a 5-mL volumetric flask.
18. Rinse the tube with the sulfuric acid solution (Step 14) several times (a minimum of two) with small amounts (~300 μ L) of toluene and elute the rinses through the clean-up column.
19. Flush the remaining sample from the column by adding small portions (~300 μ L, a minimum of twice) of toluene to the top of the column.
20. Adjust the final volume to 5.0 mL with toluene as needed.
21. Transfer an aliquot of the extract to a GC vial for analysis.

CALIBRATION AND QUALITY CONTROL:

22. Calibrate daily with at least six working standards covering the expected concentration range of the samples. Suggested working standard concentration range is 0.007-150 μ g/5 mL [6].
 - a. Prepare each working standard by spiking a known amount of the butyltin trichloride stock solution into enough pooled urine to make a total of 5.0 mL.
 - b. Prepare at least one pooled urine blank by transferring 5.0 mL of pooled urine (the same pooled urine used for creating the working standards) into a culture tube.
 - c. Prepare quality control (QC) samples by spiking known amounts of a separately prepared butyltin trichloride stock solution into pooled urine (the same pooled urine used for creating the working standards and blanks). It is recommended that two QC levels be prepared; a lower level at 3-5X the limit of quantitation (LOQ) and a higher level nearer the top end of the calibration curve. Run enough QC samples to be greater than 5% of the sample set. QC values should normally be within \pm 20% of the spiked values. If not, the batch is considered out of control, the batch data discarded, and corrective actions taken before more specimens are analyzed.
23. Process each working standard, blank, and QC sample using the same procedure as for the samples (steps 3 through 21).

24. Prepare calibration curves by plotting peak area (or peak height, although area is recommended) for the standards on the y-axis vs. concentration of analyte on the x-axis. The standard curve should have a coefficient of determination (r^2) of equal to or greater than 0.98 to be acceptable for use. Furthermore, when each standard is plugged back into the calibration equation, the value should be within $\pm 20\%$ of the expected.

MEASUREMENT:

25. Set the gas chromatograph according to manufacturer's recommendations and to conditions given on the front page of the method. With the chromatographic conditions outlined on page 1, the retention time of the butyltin trichloride derivative (butyltriethyltin) was 7.3 min. A sample chromatogram is shown in Figure 1.
26. Set the mass spectrometer according to manufacturer's recommendations and to conditions given on the front page of the method. The mass spectrum for the butyltriethyltin can be found in the backup data report [6]. The most abundant isotopic mass of this compound is 264. The monitored ions are M-85 and M-29.
27. Inject each sample, working standard, blank, and QC sample.
28. Measure peak area or peak height in each chromatogram.

NOTE: If the sample peak area or height is greater than that of the highest standard, dilute the sample extract with toluene and reanalyze. Apply the appropriate dilution factor in the calculations.

CALCULATION OF ANALYTE PER SAMPLE:

29. Determine mass of analyte in μg per 5-mL sample using the calibration curve prepared in step 24. Apply any dilution factor if needed.

NOTE: If the creatinine value of the sample was obtained, the concentration could be reported as $\mu\text{g/g}$ creatinine if desired. The mass of analyte in $\mu\text{g/L}$ can be calculated by multiplying the result by 200. The result can also be expressed in $\mu\text{g tin/volume}$ by multiplying the μg per 5-mL sample or $\mu\text{g/L}$ by the butyltin trichloride conversion factor (%tin/mole) of 0.4207.

EVALUATION OF METHOD:

The first procedure considered for this method was a modification of the Chau, *et al.* protocol using *in situ* derivatization of the alkyltin compounds by sodium tetraethylborate [9]. While this procedure was found to be generally acceptable, recoveries were found both by Chau and DataChem Laboratories (DCL) to be inferior to the tropolone extraction/ethylmagnesium bromide derivatization. A composite procedure made up of modifications of elements of both Chau's protocol and a procedure used by Meinema [10] was subsequently used at DCL. Since tin concentrations were expected to be low, a GC/MS-SIM analysis was chosen over the GC/FPD procedure. This method was evaluated over the following range: butyltin trichloride: 0.12-4.0 $\mu\text{g}/5\text{ mL}$ sample. This range represents from 3X the estimated LOQ to 100X the estimated LOQ. Six replicates were analyzed at each level. The average recovery at the various levels ranged from 103% at 3X LOQ to 110% at 30X LOQ for butyltin trichloride [6]. Recoveries were determined by quantitating against spiked and derivatized standards in urine. The analytical range of the method was extended during a secondary laboratory evaluation step (known as a User Check). Two higher concentration levels were evaluated (12.5 and 60.5 $\mu\text{g}/5\text{ mL}$) by analyzing five replicates at each level. These levels showed recoveries of 90.2 and 92.7% with relative standard deviations of 4.0 and 3.6% respectively [6]. The Limit of Detection (LOD) and LOQ were determined by analyzing a series of derivatized spiked standards with the data fitted to a quadratic or linear curve, then estimated according to the Burkart Method [11]. The LOD was determined to be 0.01 $\mu\text{g}/5\text{ mL}$ and the LOQ to be 0.04 $\mu\text{g}/5\text{ mL}$. A long-term storage study was carried out at the 10X LOQ level. Urine spiked with the analyte was stored at $-20\text{ }^\circ\text{C}$ for 1, 7, 32, 137, and 315 days and then analyzed. No significant losses were observed over the entire period [6].

Additional compounds studied:

This method was originally developed to include two other butyltin chlorides: dibutyltin dichloride and tributyltin chloride, even though butyltin trichloride is the most occupationally relevant one as it is used in the glass industry. The analytical parameters obtained during method development for these two additional compounds were also acceptable [6]. However, the data obtained during the secondary laboratory evaluation for these additional compounds were not of such a quality that they could be considered fully evaluated. Both the method development data and secondary laboratory data can be found in the method backup data report [6]. Some of the pertinent analytical parameters for these two additional compounds are listed below as well as changes/additions to the written method needed for their analysis in case there is a desire to analyze for these compounds. The properties of these additional compounds are given in Table 1.

The ranges studied for the additional compounds were 0.18-6.0 µg/5-mL sample (with additional levels of 11.9 and 57.5 µg/5 mL added during the User Check) for dibutyltin dichloride and 0.15-5.0 µg/5-mL sample (with additional levels of 12.0 and 58.5 µg/5 mL added during the User Check) for tributyltin chloride.

NOTE: the additional levels added during the User Check were not used in the following accuracy, bias, and precision calculations. These values may all be found in the method backup data report [6].

| | |
|---------------------------------------|-------------------------------------|
| ACCURACY: | Dibutyltin dichloride: ± 13.5% |
| | Tributyltin chloride: ± 8.62% |
| BIAS: | Dibutyltin dichloride: -0.091 |
| | Tributyltin chloride: -0.051 |
| OVERALL PRECISION (\hat{S}_r): | Dibutyltin dichloride: 0.0266 |
| | Tributyltin chloride: 0.0215 |
| ESTIMATED LOD: | Dibutyltin dichloride: 0.02 µg/5 mL |
| | Tributyltin chloride: 0.01 µg/5 mL |

NOTE: The tributyltin chloride LOD experiment had an interfering ion that caused this number to be more approximate than that of the other two compounds. See backup data report [6] for more information.

Recoveries ranged from 88.1% (at 30X LOQ) to 93.9% (at 10X LOQ) for dibutyltin dichloride and from 94.2% (at 10X LOQ) to 95.9% (at 100X LOQ) for tributyltin chloride [6].

Changes and additions to the method needed to incorporate these two additional compounds:

The mass spectrometer parameters should be changed to: SIM ions (*m/z*): 4-9.6 min: 178.9, 234.9, 262.9, 290.9; 9.6 min to end of run: 234.9, 262.9, 290.9.

Additional reagents required: dibutyltin dichloride, ≥95% purity and tributyltin chloride, ≥95% purity.

Retention times: dibutyltin dichloride derivative (dibutyldiethyltin), 9.2 min; tributyltin chloride derivative (tributylethyltin), 10.7 min (these peaks are shown in Figure 1.)

Conversion factors (%tin/mole) to be used if results are expressed in µg tin/volume are 0.3907 for dibutyltin dichloride and 0.3647 for tributyltin chloride.

REFERENCES:

- [1] ACGIH [2016]. TLVs and BEIs based on the documentation of the Threshold Limit Values for chemical substances and physical agents and Biological Exposure Indices. Cincinnati, Ohio: American Conference of Governmental Industrial Hygienists, www.acgih.org.
- [2] DFG [2014]. List of MAK and BAT values 2014: maximum concentrations and biological tolerance values at the workplace. Bonn, Germany: DFG: Deutsche Forschungsgemeinschaft (German Research Foundation), <http://onlinelibrary.wiley.com/book/10.1002/9783527682027>.
- [3] SUVA (Swiss National Accident Insurance Fund) [2013]. Protection de la santé au poste de travail. Valeurs limites d'exposition aux postes de travail. 3rd Ed. Lucerne, Switzerland: Schweizerische Unfallversicherungsanstalt, <https://www.suva.ch/>.
- [4] Sigma-Aldrich [2018]. www.sigmaaldrich.com.
- [5] NIOSH [2005]. Evaluation of monobutyltin trichloride exposure among glass workers. By Dowell CH, Page EH, Mueller C, Mortimer V, Snawder J. Cincinnati, OH: U.S. Department of Health and Human Services, Centers for Disease Control and Prevention, National Institute for Occupational Safety and Health, Health Hazard Evaluation Report #2003-0016-2959.
- [6] Wickman DC, Perkins JB [2005]. Backup data report for butyltin chlorides in urine method development, DataChem Laboratories, Inc. under NIOSH contract CDC-200-2001-08000.
- [7] NIOSH [1995]. Guidelines for air sampling and analytical method development and evaluation. By Kennedy ER, Fischbach TJ, Song R, Eller PM, Shulman SA. Cincinnati, OH: U.S. Department of Health and Human Services, Centers for Disease Control and Prevention, National Institute for Occupational Safety and Health, DHHS (NIOSH) Publication No. 95-117.
- [8] CDC [2007]. 2007 Guidelines for isolation precautions: preventing transmission of infectious agents in healthcare settings. By Siegel JD, Rhinehart E, Jackson M, Chiarello L, and the Healthcare Infection Control Practices Advisory Committee. Atlanta, GA: U.S. Department of Health and Human Services, Centers for Disease Control and Prevention, <http://www.cdc.gov/hicpac/2007IP/2007isolationprecautions.html>.
- [9] Chau YK, Yang F, Brown M [1997]. Evaluation of derivatization techniques for the analysis of organotin compounds in biological tissue. *Anal Chim Acta* 338:51-55.
- [10] Meinema HA, Burger-Wiersma T, Versluis-de Haan G, Gevers EC [1978]. Determination of trace amounts of butyltin compounds in aqueous systems by gas chromatography/mass spectrometry. *Environ Sci Technol* 12:288-293.
- [11] Burkart JA [1986]. General procedures for limit of detection calculations in the industrial hygiene chemistry laboratory. *Appl Ind Hyg* 1(3):153-155.
- [12] Chemical Book [2018]. www.chemicalbook.com/ChemicalProductProperty_EN_CB0262161.htm.
- [13] Synquest [2018]. www.synquestlabs.com/product/id/56422.html.

TABLE 1. GENERAL INFORMATION for additional compounds [4]

| | Dibutyltin dichloride | Tributyltin chloride |
|-----------------------|---|---|
| Formula | C ₈ H ₁₈ Cl ₂ Sn | C ₁₂ H ₂₇ ClSn |
| M.W. | 303.84 | 325.51 |
| CAS# | [683-18-1] | [1461-22-9] |
| RTECS | WH7100000 | WH6820000 |
| Synonyms | Dibutyldichlorotin dibutyldichlorostannane | chlorotributyltin tributylchlorotin TBTC Pestanal® |
| MP | 37-40 °C | -9 °C [12] -19 °C [13] |
| BP @ mmHg | 135 °C @10mm | 171-173 °C @ 25mm |
| Density | 1.36 g/cm ³ | 1.20 g/mL |
| Appearance | Beige or colorless solid | Clear, light yellow liquid |
| Vapor pressure | 0.0012 mmHg @ 25 °C | <0.01 mmHg @ 25 °C |

FIGURE 1. Chromatogram of the three butyltin derivatives: butyltriethyltin (the derivative of butyltin trichloride), dibutyldiethyltin (the derivative of dibutyltin dichloride), and tributylethyltin (the derivative of tributyltin chloride)

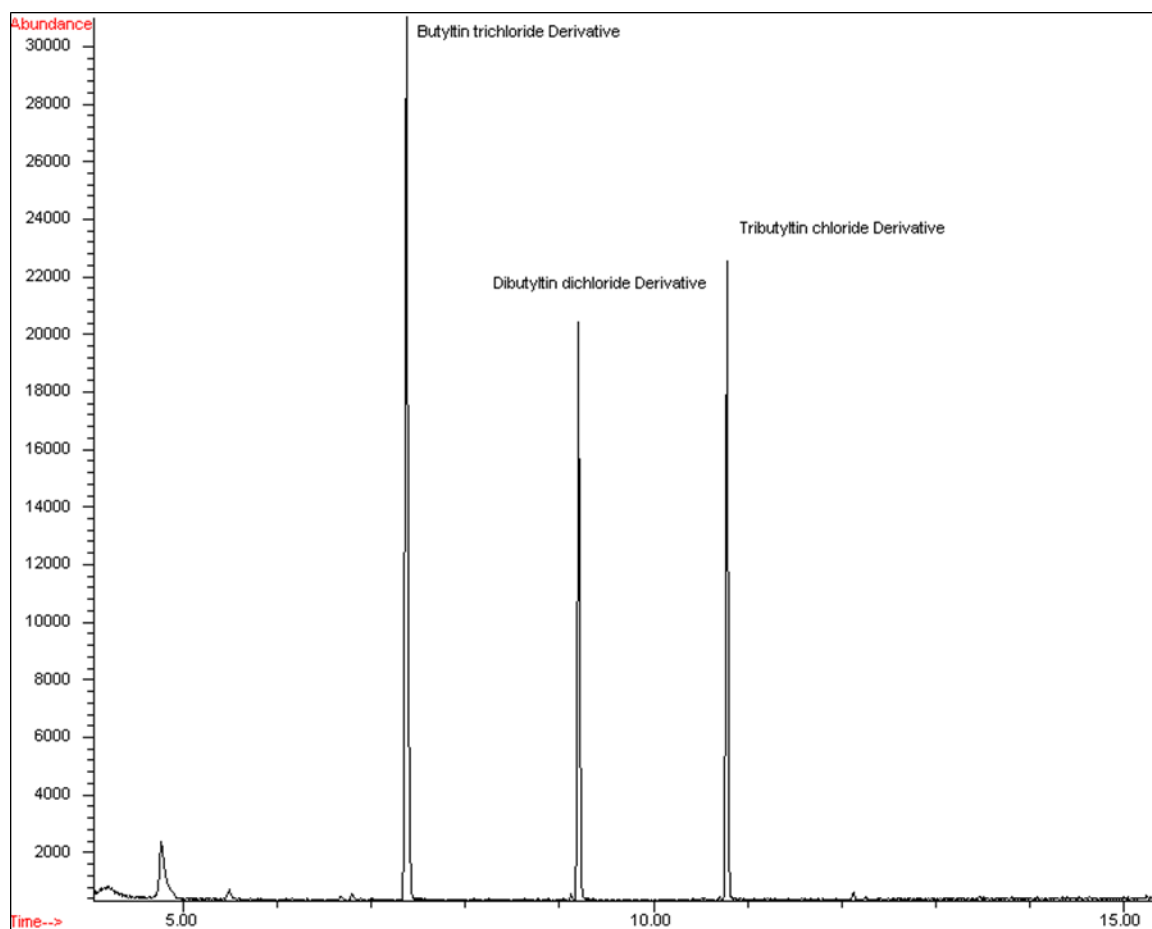

METHOD WRITTEN BY:

Don C. Wickman and James B. Perkins, DataChem Laboratories, Inc., Salt Lake City, Utah under NIOSH Contract CDC-200-2001-08000. Final editing by Dale A. Shoemaker, Ph.D., NIOSH.

Disclaimer: Mention of any company or product does not constitute endorsement by the National Institute for Occupational Safety and Health, Centers for Disease Control and Prevention. In addition, citations to Web sites external to NIOSH do not constitute NIOSH endorsement of the sponsoring organizations or their programs or products. Furthermore, NIOSH is not responsible for the content of these Web sites. All Web addresses referenced in this document were accessible at the time of publication.

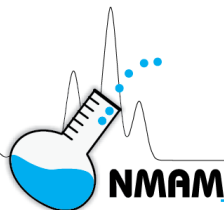

o-CRESOL in URINE

8321

CH₃C₆H₄OH

MW: 108.14

CAS: 95-48-7

RTECS: GO6300000

METHOD: 8321, Issue 1

EVALUATION: FULL

Issue 1: 18 March 2016

OSHA: N/A

NIOSH: N/A

Because data on exposure limits and guidelines may change over time, NIOSH recommends referring to references 1-4 for updated limits and guidelines concerning o-cresol and its use as a marker for other compounds.

PROPERTIES: colorless solid; MP 31 °C; BP 191 °C

Density (35 °C) = 1.0327 g/mL [5]

SYNONYMS: *ortho*-cresol, 2-cresol, *o*-cresylic acid, 1-hydroxy-2-methylbenzene, 2-hydroxytoluene, 2-methylphenol

APPLICABILITY: This method can be used for the determination of total o-cresol in urine specimens. Cresols are excreted in urine primarily as conjugates. This method uses an acid hydrolysis step to convert the conjugates to free o-cresol. (See Evaluation of Method Section.) Exposure to o-cresol will cause elevated urinary levels; however, o-cresol is a metabolite produced from toluene exposure. Not only would toluene exposure interfere with determining o-cresol exposure, but measuring o-cresol in urine is one of the recommended methods for determining toluene exposure. Recommended levels for using o-cresol to measure toluene exposure (at the time of publication of this method) include: ACGIH-TLV, 0.3 mg/g creatinine [1]; DFG-BAT, 1.5 mg/L [2]; and SUVA-VBT, 0.5 mg/L [3].

INTERFERENCES: None noted in the analytical method, but background levels of 0.032 – 0.070 µg/mL o-cresol have been observed [7-9]. These values are near and slightly above the limit of quantitation. Exposure to toluene will cause higher levels of urinary o-cresol as discussed above. p-Cresol is a normal component of human urine [10] and may, along with m-cresol, also be a co-exposure [11-12]. These two compounds have similar mass spectra to o-cresol but are chromatographically resolved under the conditions of this method [6].

OTHER METHODS: There are numerous literature methods for the determination of o-cresol in urine [10], but standardized methods from governmental agencies or consensus standards organizations are not currently available. NIOSH 8305 is a similar but only partially-validated method for phenol and p-cresol [11]. An older validated method using steam distillation and HPLC-UV detection for ~30 related compounds that includes o-cresol can be found in the German MAK collection [12].

REAGENTS:

1. o-Cresol* (≥99% purity) primary stock solution (PSS) about 10,000 µg/mL (0.100 g of o-cresol in 10 mL of methanol). Store at -10 °C ± 2 °C
2. o-Cresol intermediate solutions of 1,000 and 100 µg/mL (0.5 and 0.05 mL of PSS diluted to 5.0 mL with methanol). Store at -10 °C ± 2 °C
3. Human urine* provided by non-exposed individuals, store at < 6 °C**
4. Methanol*, GC grade or better
5. Hydrochloric acid*, concentrated, 33-38%, ACS reagent grade or better
6. Nitrobenzene (≥99% purity) internal standard (IS) solution of 500 µg/mL (0.125 g of nitrobenzene in 250 mL of methanol). Store at 10 °C ± 2 °C
7. Water, ASTM Type II [13]
8. Methyl tert-butyl ether* (MTBE), HPLC grade or better
9. Sodium sulfate, granular, anhydrous, ≥99% purity.
10. Helium, UHP or Grade 5

*See SPECIAL PRECAUTIONS.

**Human urine recommended due to evidence of column problems caused by synthetic urine.

EQUIPMENT:

1. GC-MS capable of selected ion monitoring with data system, autosampler, and column (page 8321-1)
2. Flasks, glass, volumetric: 5, 10 and 250 mL
3. Syringes, glass: 10, 50, 100, 500 and 2,500 µL
4. Tubes, centrifuge, 15-mL graduated polypropylene, with caps
5. Pipetter 1-10 mL, with disposable tips
6. Pasteur pipettes, glass
7. Water bath, 95 °C
8. Wash bottle
9. Vials, autosampler, amber glass
10. Cold storage for -10 °C and 4 °C
11. Bottles, 125 mL polyethylene
12. Analytical balance, to ±0.0001 g.

SPECIAL PRECAUTIONS: Wear gloves, lab coat, and safety glasses while handling all chemicals and human urine products. Disposable plastic, glass, and paper (pipet tips, gloves, etc.) that contact urine should be placed in a biohazard container. Standard precautions should always be used when handling bodily fluids and/or extracts of bodily fluids [14]. Handle urine samples and urine extracts using proper gloves. All work should be performed in a fume hood. Methanol and MTBE are both flammable. Hydrochloric acid is an extremely corrosive chemical capable of severe tissue damage.

SAMPLING:

1. Collect 50-100 mL urine in a 125 mL polyethylene bottle. Collect 2 urine specimens for each worker: one specimen before exposure and one specimen after.
2. Collect and pool urine specimens from unexposed workers to be used for controls.
3. Tightly cap each bottle and ship refrigerated or frozen in an insulated container to maintain the temperature at 6 °C or below.

SAMPLE PREPARATION:

4. Allow urine to reach room temperature and mix thoroughly.
NOTE: If desired, remove an aliquot of urine to determine creatinine levels.
5. Dispense a 5-mL aliquot of the urine specimen into a 15-mL graduated centrifuge tube.
6. Using a Pasteur pipette, add 1 mL of concentrated HCl, up to the 6 mL calibration mark in the tube.
7. Cap the tube. Shake vigorously for one minute.
8. Place the tube in a water bath at 95 °C for 1.5 hr.
NOTE: Covering the water bath may be required to maintain the temperature at 95 °C.
9. Remove the tube from the bath and let it cool to room temperature.
10. Add 250 µL of the nitrobenzene IS solution.
11. Add water (ASTM Type II) to the tube, filling it to the 10 mL calibration mark.
12. Pipet 2 mL of MTBE to the tube and cap it.
13. Shake the tube vigorously for 2 min.
14. Allow the phases to separate.
15. Transfer the top organic phase to an amber GC vial containing approximately 0.2 g of anhydrous sodium sulfate (to ensure the dryness of the organic fraction).
16. Cap the vials and store at <6 °C until GC-MS analysis.

CALIBRATION AND QUALITY CONTROL:

17. Calibrate daily with nine working standards containing *o*-cresol at approximately the following concentrations: 0.04, 0.1, 0.2, 1, 2, 10, 20, 40 and 60 µg/mL.
 - a. Prepare the standards by adding measured amounts of *o*-cresol intermediate stock solutions to centrifuge tubes containing 5 mL of control urine.
 - b. Process the standards following the same procedure used for the samples (steps 4-16).
 - c. Prepare at least one method blank for every 20 samples by taking an aliquot of 5 mL control urine and processing it in the same manner as the samples (steps 4-16).
 - d. Prepare at least two levels of quality control (QC) samples using a separate source of *o*-cresol and prepare in the same manner as the calibration standards within the analytical range. These levels should be at roughly 10 times the limit of quantitation (LOQ) and 100 X LOQ. Analyze at least two QC samples of different concentration for every 20 samples.
18. Prepare a calibration graph by plotting, for each working standard, the normalized analyte response (peak area of analyte divided by the peak area of the internal standard on the same chromatogram) on the y-axis vs. µg of analyte/mL of urine on the x-axis. The simplest model that adequately describes the data should be used, but either a linear (most likely 1/X weighted because of the range of the calibration curve) or a quadratic model may be utilized in processing the analytical data. Because there may be detectable levels of *o*-cresol in the pooled urine blanks, before plotting the calibration graph, subtract the normalized analyte response of the pooled urine blank from the normalized analyte response of each working standard. The standard curve should have a coefficient of determination (r^2) of equal to or greater than 0.98 to be acceptable for use. Furthermore, when each standard is substituted back into the calibration equation, the value should be within ±20% of the expected value.
19. QC values should be within ±20% of the spiked values. If not, the batch is considered out of control, the batch data discarded, and corrective actions taken before more samples are analyzed.

MEASUREMENT AND CALCULATIONS:

20. Set gas chromatograph according to manufacturer's recommendations and to conditions given on page 8321-1.
21. Set the mass spectrometer according to manufacturer's recommendations, to conditions given on page 8321-1, and to SIM for ions m/z 77, 107, 108, and 123.
22. Inject 2 μL of each sample, blank and QC sample.
23. Measure peak areas for *o*-cresol and nitrobenzene in the chromatograms. Divide the peak area of *o*-cresol by the peak area of nitrobenzene in the same chromatogram.

CALCULATIONS:

24. Determine concentration of *o*-cresol from the calibration curve produced in step 18.

EVALUATION OF METHOD:

This method was evaluated at five concentration levels over the range 0.0214 – 2.14 $\mu\text{g}/\text{mL}$. This range represents from 1 x LOQ to 100 x LOQ. Six replicates were analyzed at each level. The average recoveries at the various levels ranged from 86.8 to 118.4%. The limit of detection (LOD) and LOQ study was performed by analyzing a series of standards ranging from 0.0107 to 64.1 $\mu\text{g}/\text{mL}$, fitting the data to a quadratic curve, and estimating the values using "Burkart's Method" [15]. The value obtained for the LOD by this method (0.009 $\mu\text{g}/\text{mL}$) was lower than the lowest standard in the determination (0.0107 $\mu\text{g}/\text{mL}$), so the LOD used for the method was the value of the lowest standard, 0.01 $\mu\text{g}/\text{mL}$. A long-term storage study was carried out at the 30 x LOQ level: pooled urine specimens spiked with *o*-cresol at 0.854 $\mu\text{g}/\text{mL}$ were stored at 4 °C for 1, 7, 10, 14, 21 and 30 days and then analyzed. The recoveries across the entire study (1-30 days) were between 92-112%. Another set of specimens stored at room temperature were analyzed after 1 and 7 days, producing recoveries ranging from 90-102% [6]. The analytical range of the method was extended during a secondary laboratory validation step. Two concentration levels were evaluated (5.06 and 30.30 $\mu\text{g}/\text{mL}$) by analyzing five replicates at each level. These levels showed recoveries of 100.2 and 92.8% with relative standard deviations of 0.63 and 1.40% respectively [6].

In order to minimize confusion among users of NIOSH Method 8321, the authors would like to re-emphasize that *p*-cresol is an endogenous human metabolite produced from protein breakdown and will always be found in human urine [10]. The mass spectrum of *p*-cresol is quite similar to that of *o*-cresol and so there is some possibility of peak misidentification. Fortunately, while the peaks are near each other in the chromatogram under the method conditions, the *p*-cresol peak elutes later, is adequately resolved, and thus will not interfere with *o*-cresol analyses [6].

Discussion concerning acid hydrolysis step: The efficiency of the acid hydrolysis step in this procedure was not evaluated. A common method of converting these conjugates (glucuronides and sulfates) back to the parent compounds is heating the sample with a mineral acid. Several literature examples that employ hydrochloric acid under very similar conditions can be found [8,9,12,16-18]. A common thread among these methods is that none of them appear to investigate the efficiency of the acid hydrolysis step. Fustinoni et al. did investigate the hydrolysis step both in terms of amount of acid used and reaction time required [19]. They found that 50 μL of concentrated HCl per 300 μL of urine and reacting for 60 min at 100 °C gave yields of greater than 97%. NIOSH Method 8321 uses 1 mL concentrated HCl per 5 mL urine, heating at 95 °C for 1.5 h, which are nearly identical conditions. These similar conditions should assure adequate efficiency of the acid hydrolysis step and have proven to not be detrimental to the *o*-cresol [6].

REFERENCES:

- [1] ACGIH [2014]. TLVs and BEIs based on the documentation of the Threshold Limit Values for chemical substances and physical agents and Biological Exposure Indices. Cincinnati, Ohio: American Conference of Governmental Industrial Hygienists. [www.acgih.org]. Date accessed: May 2014.
- [2] Commission for the Investigation of Health Hazards of Chemical Compounds in the Work Area [2014]. List of MAK and BAT values 2014; Maximum concentrations and biological tolerance values at the workplace. DFG: Deutsche Forschungsgemeinschaft, [http://onlinelibrary.wiley.com/book/10.1002/9783527682027]. Date accessed: January 2015.
- [3] SUVA (Swiss National Accident Insurance Fund) [2013]. Protection de la santé au poste de travail. Valeurs limites d'exposition aux postes de travail. 3rd Ed. [https://www.suva.ch/]. Date accessed: May 2014.
- [4] Institut für Arbeitsschutz der Deutschen Gesetzlichen Unfallversicherung (IFA) [http://www.dguv.de/ifa/GESTIS/]. Date accessed: May 2014.
- [5] CRC Handbook of Chemistry and Physics [2013]. 94th Edition, CRC Press, Taylor and Francis Group, Boca Raton, FL.
- [6] Siso MC, Perkins JB [2005]. Backup data report for *o*-cresol in urine method development. DataChem Laboratories, Inc., under NIOSH contract CDC-200-2001-08000.
- [7] Bieniek G [1997]. Urinary excretion of phenols as an indicator of occupational exposure in the coke-plant industry. *Int Arch Occup Environ Health* 70(5):334-340.
- [8] Inoue O, Kanno E, Kasai K, Ukai H, Okamoto S, Ikeda M [2004]. Benzylmercapturic acid is superior to hippuric acid and *o*-cresol as a urinary marker of occupational exposure to toluene. *Toxicol Lett* 147(2):177-186.
- [9] Bahrami A, Jonidi-Jafari A, Folladi B, Mahjub H, Sadri Q, Zadeh MM [2005]. Comparison of urinary *o*-cresol and hippuric acid in drivers, gasoline station workers and painters exposed to toluene in west of Iran. *Pak J Biol Sci* 8(7):1001-1005.
- [10] ATSDR [2008]. Toxicological profile for cresols. [https://www.atsdr.cdc.gov]. Date accessed: February 2015.
- [11] NIOSH [1994]. Phenol and *p*-cresol in urine: Method 8305. In Eller PM, Cassinelli ME, eds. NIOSH manual of analytical methods, 4th ed. Cincinnati, OH: U.S. Department of Health and Human Services, Centers for Disease Control and Prevention, National Institute for Occupational Safety and Health, DHHS (NIOSH) Publication No. 94-113.
- [12] Lewalter J, Schucht T [2012]. Benzene derivatives, suitable for steam distillation (phenol; *m*-/*p*-cresol; *o*-cresol; *o*-chlorophenol; *o*-nitrophenol; *p*-chlorophenol; nitrobenzene; 1,2-dinitrobenzene; 2-chloro-5-methylphenol; 2,5-dichlorophenol; 3,4-dichlorophenol; 2,3-dinitrotoluene) [Biomonitoring Methods, 1985]. The MAK Collection for Occupational Health and Safety, pp 31–56.
- [13] ASTM [2011]. ASTM D1193-06(2011), Standard specification for reagent water, ASTM International, West Conshohocken, PA, 2011, www.astm.org.

- [14] CDC [2007]. 2007 Guidelines for isolation precautions: preventing transmission of infectious agents in healthcare settings. [<http://www.cdc.gov/hicpac/2007IP/2007isolationprecautions.html>]. Date accessed: April 2013.
- [15] Burkart JA [1986]. General procedures for limit of detection calculations in the industrial hygiene chemistry laboratory, *Appl Ind Hyg* 1(3):153-155.
- [16] Hasegawa K, Shiojima S, Koizumi A, Ikeda M [1983]. Hippuric acid and o-cresol in the workers of urine exposed to toluene. *Int Arch Occup Environ Health* 52(3):197-208.
- [17] Truchon G, Tardif R, Brodeur J [1999]. o-Cresol: A good indicator of exposure to low levels of toluene. *Appl Occup Environ Hyg* 14(10):677-681.
- [18] de Paiva MJN, Martins I, de Siqueira MEPB [2007]. Analysis of *ortho*-cresol in urine by solid phase microextraction-capillary gas chromatography. *J Braz Chem Soc* 18(5):1034-1039.
- [19] Fustinoni S, Mercadante R, Campo L, Scibetta L, Valla C, Foà V [2005]. Determination of urinary *ortho*- and *meta*-cresol in humans by headspace SPME gas chromatography/mass spectrometry. *J Chromatogr B* 817:309-317.

METHOD WRITTEN BY:

María Carolina Siso and James B. Perkins, DataChem Laboratories, Inc., Salt Lake City, Utah under NIOSH Contract CDC-200-2001-08000. Final editing by Dale A. Shoemaker, Ph.D., NIOSH.

Disclaimer: Mention of any company or product does not constitute endorsement by NIOSH. In addition, citations to websites external to NIOSH do not constitute NIOSH endorsement of the sponsoring organizations or their programs or products. Furthermore, NIOSH is not responsible for the content of these websites. All web addresses referenced in this document were accessible as of the publication date.

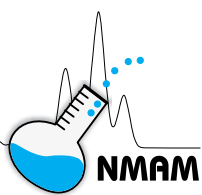

TRICHLOROACETIC ACID IN URINE

8322

FORMULA: C₂HCl₃O₂

MW: 163.39

CAS: 76-03-9

RTECS: AJ7875000

METHOD: 8322, Issue 1

EVALUATION: FULL

Issue 1: 17 April 2015

OSHA & NIOSH: N/A

Other OELS: Because data on exposure limits and guidelines may change over time, NIOSH recommends referring to the following sources for updated limits. [1 - 4]

PROPERTIES: White solid; mp 59.1 °C; bp 198.2 °C; d = 1.61 g/cm³ [5]

BIOLOGICAL INDICATOR OF: Exposure to trichloroethylene, trichloroacetic acid, methyl chloroform, tetrachloroethene, chloral hydrate

SYNONYMS: Trichloroethanoic acid, Aceto-caustin

| SAMPLING | | MEASUREMENT | |
|---|--|-----------------------|---|
| SPECIMEN: Urine | | TECHNIQUE | GAS CHROMATOGRAPHY with ELECTRON CAPTURE DETECTOR (GC-ECD) |
| VOLUME: At least 10 mL | | ANALYTES: | Trichloroacetic acid (determined as the methyl ester) |
| PRESERVATIVE: None | | PROCEDURE: | Methylation of an aliquot with BF ₃ ·methanol to form the methyl ester followed by extraction into toluene |
| SHIPMENT: Freeze urine; ship in dry ice in an insulated container. | | INJECTION: | 1 µL, splitless for 0.5 min |
| SAMPLE STABILITY: Stable at least 30 days at -17 °C [6] | | TEMPERATURES | |
| CONTROLS: Urine specimens from matched population of non-exposed persons | | -INJECTION: | 250 °C |
| | | -DETECTOR: | 300 °C |
| | | -OVEN: | 80 °C (hold for 0.5 min), 80 to 180 °C at 20 °C/min, hold for 7 min |
| ACCURACY | | CARRIER GAS: | Helium, ~3.5 mL/min |
| RANGE STUDIED: | 0.9 to 100 µg/mL (as trichloroacetic acid) | MAKEUP GAS: | Nitrogen, 40 mL/min |
| BIAS: | 0.0113 | COLUMN: | Capillary, fused silica, 6% cyanopropyl-phenyl-94% dimethylpolysiloxane, 75 m x 0.53 mm ID, 3 µm film |
| OVERALL PRECISION (S_r): | 0.03656 | CALIBRATION: | Trichloroacetic acid prepared in water to cover range and derivatized with the samples |
| ACCURACY: | 7.5% | ESTIMATED LOD: | 0.08 µg/mL (as trichloroacetic acid) [6] |

APPLICABILITY: This method can be used for the determination of trichloroacetic acid (TCAA) in urine specimens. TCAA is one of several metabolites detected after exposure to a variety of chlorinated compounds (representative compounds listed above) or from contaminated drinking water [7-11].

INTERFERENCES: None observed in the analytical method apart from some carryover issues (see Evaluation of Method section.) TCAA is a non-specific metabolite of several compounds. Urinary TCAA levels reflect exposure to any and all of these precursors. Background TCAA was detected in 76% of urine samples in a US general population sample, with a median concentration of 3.3 µg/L, approximately 300 times lower than the range of this method [12].

OTHER METHODS: There are numerous literature methods for the determination of TCAA in urine [13]. The National Center for Environmental Health/Centers for Disease Control and Prevention (NCEH/CDC) has a method that is more expensive but also significantly more sensitive [11]. This method is based on the procedure used by O'Donnell [7] with some modifications.

REAGENTS:

1. Sodium trichloroacetate [CAS #650-51-1], 97% purity or greater*
2. Boron trifluoride-methanol solution, 14%*
3. Toluene, ACS reagent grade or better*
4. Sodium sulfate, anhydrous, granular; reagent grade or better
5. Acetic acid, glacial; reagent grade or better*
6. Acetone, reagent grade or better*
7. Methanol, reagent grade or better*
8. Helium, purified
9. Nitrogen, Ultra High Purity or P5
10. Water, ASTM Type II [14]

SOLUTIONS:

1. 1:3 glacial acetic acid:deionized water
2. 1:1 acetone:methanol

* See **SPECIAL PRECAUTIONS**

EQUIPMENT:

1. Centrifuge tubes, polypropylene, ~15-mL, with screw caps, or other suitable container for specimen collection and storage
2. Gas chromatograph with electron capture detector, autosampler, data collection system and column (page 8322-1)
3. Microliter syringes, various sizes
4. Volumetric flasks, glass, various sizes
5. Adjustable pipettor with disposable plastic tips, 0.1 to 1-mL
6. Disposable Pasteur transfer pipettes, 15 and 23 cm
7. Culture tubes, 13 mm x 100 mm (~8 mL), with PTFE-lined caps
8. Vortex mixer
9. Glass wool
10. Vials, autosampler, glass, 2-mL with caps
11. Oven, capable of maintaining 60 °C

SPECIAL PRECAUTIONS: Standard precautions should always be used when handling bodily fluids and/or extracts of bodily fluids [15]. Handle urine specimens and urine extracts using powder-free latex or nitrile gloves. Acetic acid, acetone, toluene, and methanol are flammable; handle with care and use in a chemical fume hood. Handle all chemicals using the required safety precautions. Reagents with manufacturer expiration dates should be observed. The Environmental Protection Agency (EPA) has designated TCAA as a known mouse carcinogen and a possible human carcinogen [16].

SAMPLING:

1. Collect at least 10 mL of urine in ~15-mL polypropylene tubes or other suitable container.
NOTE: Because of the relatively lengthy half-life values of TCAA, ACGIH recommends sampling at the end of shift at the end of workweek [1].
2. Freeze the urine and ship in dry ice in an insulated container.
Reminder: Commercial shippers have special labeling requirements for packages containing biological samples and dry ice.

SAMPLE PREPARATION:

3. Thaw urine specimens, bring to room temperature, and mix thoroughly.
4. Place 200 µL of urine specimen in an 8-mL glass culture tube with a PTFE-lined cap.
5. Add 0.5 mL 14% boron trifluoride in methanol; cap and mix.
6. Heat in oven at 60 °C for a minimum of 1.5 hr (maximum 2.5 hr).
7. Cool to room temperature and then add 2.0 mL toluene.
8. Vortex or shake vigorously for 1 min.
9. After the layers separate, transfer the upper toluene layer to a drying column containing anhydrous sodium sulfate. The drying columns are prepared in 15-cm Pasteur pipettes with a glass wool plug and about 200 to 300 mg anhydrous sodium sulfate, sufficient to form a bed depth of ~1 cm.
10. Collect the eluate in a 2-mL GC vial. Cap vial.

CALIBRATION AND QUALITY CONTROL:

11. Prepare a stock solution by accurately weighing a known quantity of sodium trichloroacetate into a volumetric flask. Add a known volume of deionized water and mix. Convert the weight of the sodium trichloroacetate to TCAA by multiplying by 0.8814 (MW TCAA divided by MW sodium trichloroacetate = 0.8814). As an example, 34 mg of sodium trichloroacetate into a 10-mL flask makes a 3 mg/mL stock solution to be used in preparing the calibration standards.
NOTE: Sodium trichloroacetate was used instead of trichloroacetic acid for all phases of this method development as well as in the preparation of standards. Trichloroacetic acid is very hygroscopic; the salt is much less so.
12. Prepare working (calibration) standards by serial dilution to cover the analytical range. A suggested working standard concentration range is 0.08 to 300 µg/mL. Withdraw 200 µL of each calibration standard and follow steps 4 through 10.
13. Determine the retention time for the analyte of interest.
14. Prepare at least one blank urine specimen without an analyte spike to verify whether the source (of blank urine) contained no detectable quantity of TCAA.
15. Prepare at least two levels of quality control spikes of TCAA, sodium salt to be analyzed with each analysis batch. These levels should be at ~10 X the limit of quantitation (LOQ) and 200 X LOQ, but can be adjusted to better suit the anticipated levels of the set of specimens. QC samples must be analyzed with every batch such that they constitute 10% of the sample batch.
16. QC values must be within ±20% of the spiked values. If not, the batch is considered out of control, the batch data discarded, and corrective actions taken before more samples are analyzed.
17. Calibrate daily with at least six liquid working standards covering the expected concentration range of the samples.

MEASUREMENT:

PRECAUTION: SYRINGE-RINSE SOLUTIONS: Toluene will extract material from some urine specimens that may eventually clog the syringe and cause injection errors unless the syringe is rinsed with the following solutions following each injection.

First rinse solution: 1:3 glacial acetic acid:deionized water

Second rinse solution: 1:1 acetone:methanol

18. Set the gas chromatograph according to manufacturer's recommendations and to conditions given on page 8322-1. With the chromatographic conditions listed, the retention time of the methyl ester of TCAA was 8.87 min [6].
19. Inject each of the samples, standards, blanks, and quality control samples.
20. Measure peak area or peak height; peak area is recommended.
NOTE: If the sample peak area or height is greater than that of the highest calibration standard, dilute with toluene and reanalyze. Apply the appropriate dilution factor in the calculations.
21. Prepare a calibration curve by plotting instrument responses (usually peak area) for the standards vs. concentration. The simplest model that adequately describes the data should be used, but either a linear (mostly likely 1/x weighted because of the range of the calibration curve) or a quadratic model may be utilized in processing the analytical results. The standard curve must have a coefficient of determination (r^2) of equal to or greater than 0.98 to be acceptable for use. Furthermore, when each standard is plugged back into the calibration equation, the measured value must be within ±20% of the expected value.

CALCULATION OF ANALYTE PER SAMPLE:

22. Determine the concentration of TCAA in µg/mL (mg/L) using the response of each sample and the calibration curve prepared in step 21. Apply any dilution factor if applicable.
NOTE: If the creatinine value is available, the concentration may be reported as µg/g creatinine if desired.

EVALUATION OF METHOD:

This method was evaluated over a range of 0.9-30 µg/mL. This range covers 3x, 10x, 30x, and 100x of the estimated LOQ. Six replicates were prepared and analyzed at each concentration level. The average recoveries for each of the concentration levels were 94.8% (3 x LOQ), 102.3% (10 x LOQ), 110.4% (30 x LOQ), and 97.1% (100 x LOQ). Recoveries were determined by comparison against spiked and derivatized liquid standards (standards prepared in deionized water). The upper concentration range was extended to 100 µg/mL during testing by an independent laboratory. Five samples were analyzed at this concentration and the average recovery was 105.0%. Overall accuracy was calculated to be 7.5%; bias was 0.0113, and overall precision was 0.0366 [6]. The limit of detection (LOD) and LOQ were determined by analyzing a series of derivatized spiked standards, with the data fitted to a quadratic curve, then estimated according to the Burkart method [17]. A long-term storage stability study was carried out at the 10x, 30x, and 100x LOQ levels. Urine samples were spiked with trichloroacetate and stored at -17 °C for 7, 14, 21, 30, and 46 days and then analyzed. Recoveries at 30 and 46 days were all greater than 90% [6].

During the testing performed by the independent laboratory ("User Check"), broad, interfering carryover peaks from the urine matrix were noticed. The lab found that raising the final temperature of the GC program to 240 °C (instead of 180 °C) and adding a longer hold time 10 min (instead of 7 min) reduced the carryover problem, allowing more precise and accurate measurement of the peak of interest. This adjusted GC program would now be: 80 °C for 0.5 min, heat to 240 °C at 20 °C/min, and hold for 10 min. Either set of conditions may be used.

NOTE: While the overall accuracy and precision for the User-Check samples were within acceptable limits [6], there were spurious results in 10% of the samples (2 out of 20.) No reason is known for these outliers, nor were the samples able to be re-injected, re-extracted, or re-analyzed. To improve user confidence in the results obtained by this method, it is suggested to randomly run duplicate analyses of 10-20% of the samples and to randomly re-inject 10-20% of the samples. If the method is used in an on-going manner and no problems or spurious results are noted, this recommendation could be lowered or eliminated.

REFERENCES:

- [1] ACGIH [2014]. TLVs and BEIs based on the documentation of the Threshold Limit Values for chemical substances and physical agents and Biological Exposure Indices. Cincinnati, Ohio: American Conference of Governmental Industrial Hygienists. [www.acgih.org] Date accessed May 2014.
- [2] Commission for the Investigation of Health Hazards of Chemical Compounds in the Work Area [2014]. List of MAK and BAT values 2014; Maximum concentrations and biological tolerance values at the workplace. DFG: Deutsche Forschungsgemeinschaft. [http://onlinelibrary.wiley.com/book/10.1002/9783527682027] Date accessed January 2015.
- [3] SUVA (Swiss National Accident Insurance Fund) [2013]. Protection de la santé au poste de travail. Valeurs limites d'exposition aux postes de travail. 3rd Ed. [https://www.suva.ch/] Date accessed May 2014.
- [4] Institut für Arbeitsschutz der Deutschen Gesetzlichen Unfallversicherung [IFA] http://www.dguv.de/ifa/GESTIS] Date accessed January 2015.
- [5] CRC Handbook of Chemistry and Physics [2013]. 94th Edition, CRC Press, Taylor and Francis Group, Boca Raton, FL.
- [6] Wickman DC, Perkins JB, Reynolds JM [2012]. Backup data report for trichloroacetic acid in urine, ALS Environmental (formerly DataChem Laboratories Inc.) under NIOSH contract CDC-200-2001-08000.

- [7] O'Donnell GE, Juska A, Geyer R, Faiz M, Stalder S [1995]. Analysis of trichloroacetic acid in the urine of workers occupationally exposed to trichloroethylene by capillary gas chromatography. *J Chromatogr A* 709:313-317.
- [8] Bernauer U, Birner G, Dekant W, Henschler D [1996]. Biotransformation of trichloroethylene: Dose-dependent excretion of 2,2,2-trichloro-metabolites and mercapturic acids in rats and humans after inhalation. *Arch Toxicol* 70:338-346.
- [9] Raaschou-Nielsen O, Hansen J, Christensen JM, Blot WJ, McLaughlin JK, Olsen JH [2001]. Urinary concentrations of trichloroacetic acid in Danish workers exposed to trichloroethylene, 1947-1985. *Am J Ind Med.* 39:320-327.
- [10] Vartiainen T, Pukkala E, Rienoja T, Strandman T, Kaksonen K [1993]. Population exposure to tri- and tetrachloroethylene and cancer risk: Two cases of drinking water pollution. *Chemosphere*, 27(7):1171-1181.
- [11] Kuklennyik Z, Ashley DL, Calafat AM [2002]. Quantitative detection of trichloroacetic acid in human urine using isotope dilution high-performance liquid chromatography-electrospray ionization tandem mass spectrometry. *Anal Chem* 74(9):2058-2063.
- [12] Calafat AM, Kuklennyik Z, Caudill SP, Ashley DL [2003]. Urinary levels of trichloroacetic acid, a disinfection by-product in chlorinated drinking water, in a human reference population. *Environ Health Perspect* 111:151-154.
- [13] Delinsky AD, Bruckner JV, Bartlett MG [2005]. A review of analytical methods for the determination of trichloroethylene and its major metabolites chloral hydrate, trichloroacetic acid and dichloroacetic acid. *Biomed Chromatogr* 19:617-639.
- [14] ASTM [2011]. ASTM D1193, Standard specification for reagent water. ASTM International, West Conshohocken, PA. [www.astm.org] Date accessed: April 2013. DOI 10.1520/D1193-06R11.
- [15] CDC [2007]. 2007 Guidelines for isolation precautions: Preventing transmission of infectious agents in healthcare settings. [http://www.cdc.gov/hicpac/2007IP/2007isolationprecautions.html] Date accessed: April 2013.
- [16] US EPA [2011]. Trichloroacetic acid (CASRN 76-03-9). United States Environmental Protection Agency. [www.epa.gov/iris/subst/0655.htm] date accessed April 7, 2014.
- [17] Burkart JA [1986]. General procedures for limit of detection calculations in the industrial hygiene chemistry laboratory. *Appl Ind Hyg* 1(3):153-155.

METHOD WRITTEN BY: Don C. Wickman and James B. Perkins; DataChem Laboratories, Inc., Salt Lake City, Utah, under contract CDC 200-2001-08000.

METHOD EDITED BY: John M. Reynolds, ALS Environmental (formerly DataChem Laboratories, Inc.), Salt Lake City, Utah and Dale A. Shoemaker, Ph.D., NIOSH/DART/CEMB.

Disclaimer: Mention of any company or product does not constitute endorsement by NIOSH. In addition, citations to websites external to NIOSH do not constitute NIOSH endorsement of the sponsoring organizations or their programs or products. Furthermore, NIOSH is not responsible for the content of these websites. All web addresses referenced in this document were accessible as of the publication date.

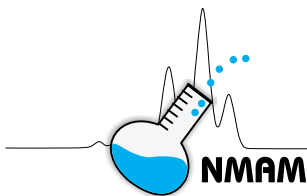

3-BROMOPROPIONIC ACID in URINE

8324

metabolite of 1-bromopropane

FORMULA: $C_3H_5BrO_2$

MW: 152.97

CAS: 590-92-1

RTECS: UE7875000

METHOD: 8324, Issue 1

EVALUATION: FULL

Issue 1: 12 September 2014

Exposure limits and guidelines:

OSHA: None

NIOSH: None

Other OELs: Because data on exposure limits and guidelines may change over time, NIOSH recommends referring to the following sources for updated limits [1 - 4].

PROPERTIES: Solid; d 1.48 g/mL at 25 °C; MP 58-62 °C

BIOLOGICAL

INDICATOR OF: Exposure to 1-bromopropane

SYNONYMS: β -Bromopropionic acid; 2-carboxyethylbromide.

| SAMPLING | MEASUREMENT |
|---|---|
| <p>SPECIMEN: Urine</p> <p>VOLUME: At least 15 mL</p> <p>PRESERVATIVE: None added Refrigerate or freeze upon collection</p> <p>SHIPMENT: Ship cold or frozen with ice or dry ice Freeze upon receipt at the laboratory</p> <p>SAMPLE STABILITY: Stable in frozen urine for at least 30 days</p> <p>CONTROLS: Urine specimens obtained from non-exposed individuals</p> | <p>TECHNIQUE: GAS CHROMATOGRAPHY, MASS SPECTROMETRY with SELECTED ION MONITORING (GC/MS-SIM)</p> <p>ANALYTE: tert-butyltrimethylsilane derivative of 3-bromopropionic acid</p> <p>EXTRACTION: Liquid-liquid extraction (LLE)</p> <p>INJECTION VOLUME: 0.5 μL, splitless</p> <p>TEMPERATURES</p> <ul style="list-style-type: none"> - INJECTION: 200 °C - COLUMN: 60 °C initial, 4 °C/min to 180 °C, 15 °C/min to 255 °C, post-run at 270 °C for 5 min - DETECTOR: Source 230 °C, Quadrupole 150 °C; Solvent delay, 15 min <p>RUN TIME: Approximately 50 minute cycle time</p> <p>CARRIER GAS: Helium, 0.8 mL/min constant flow</p> <p>COLUMN: Capillary, fused silica, 100% dimethyl-polysiloxane, 50 m X 0.20 mm (ID), 0.33 μm film thickness</p> <p>CALIBRATION: Analyte in control urine; with internal standard</p> <p>QUALITY CONTROL: At least one level of spiked urine sample prepared from a separately weighed stock solution</p> <p>RANGE: 2.0 to 100 μg/mL</p> <p>ESTIMATED LOD: Approximately 0.01 μg/mL (IUPAC) [6]. 0.1 μg/mL is the lowest calibration standard.</p> |
| ACCURACY | |
| <p>RANGE STUDIED: Table 1</p> <p>BIAS: None established</p> <p>PRECISION: Table 1</p> <p>RECOVERY ACCURACY: Full recovery (95% overall) was established by a spiked urine recovery, overall RSD was $\pm 3.1\%$ (Table 1).</p> <p>The definitions of precision and accuracy in this method are those utilized by the US Food and Drug Administration [5].</p> | |

APPLICABILITY: 3-Bromopropionic acid (3-BPA) has been reported to be a rat metabolite [7] and is a potential human biomarker for exposure to 1-bromopropane. This method measures the quantity of free 3-BPA in urine. 1-Bromopropane is used as an industrial solvent. In one limited study, 3-BPA was not detected in individuals exposed to low levels of 1-bromopropane [8].

INTERFERENCES: None found or identified.

OTHER METHODS: This method is from the one described by B'Hymer and Cheever [9] and further investigated by Mathias, et al. [8].

REAGENTS:

1. 3-Bromopropionic acid (3-BPA) reference standard as a 1.0 mg/mL stock solution in deionized water. Store in a refrigerator.
2. 3-Chloropropionic acid (3-CPA) reference standard, 20 µg/mL in deionized water, internal standard solution. Store in a refrigerator.
3. Ethyl acetate, HPLC grade or better*
4. N-Methyl-N-(tert-butyldimethylsilyl) trifluoroacetamide (MTBSTFA) with 1% tert-butyldimethylchlorosilane (TBDMCS)
5. Magnesium sulfate, anhydrous, powdered, ACS reagent grade
6. Hydrochloric acid, concentrated, ACS reagent grade
7. Water, deionized (ASTM type II)
8. Nitrogen, prepurified grade or better
9. Urine, non-exposed*

* See SPECIAL PRECAUTIONS

EQUIPMENT:

1. Gas chromatograph with mass spectrometric detector, column, autosampler, and data collector (page 8324-1)
2. Bottles, polypropylene, 125-mL with caps
3. Analytical balance, to ±0.0001 g
4. Analytical evaporator with nitrogen gas sweep
5. Test-tube vortex mixer
6. Heating block or oven
7. Automatic pipettor with disposable tips
8. Repeating pipet dispenser, 1 Liter
9. Tubes, disposable screw-top culture (16 X 100 mm and 16 X 150 mm), with polytetrafluoroethylene (PFTE)-lined caps
10. Metal spatula
11. Flasks, volumetric; 10, 50 and 100-mL
12. Autosampler vials, 2 mL, silanized, with caps and septa
13. Glass funnels
14. Glass wool, silanized
15. Disposable glass pipets
16. Dry ice or bagged refrigerant

SPECIAL PRECAUTIONS: Standard precautions should always be used when handling bodily fluids and/or extracts of bodily fluids [10]. Handle urine samples and urine extracts using powder-free latex or nitrile gloves. Ethyl acetate and MTBSTFA are flammable; handle with care and use in a chemical fume hood. Handle all chemicals using the required safety precautions. Manufacturer expiration dates for reagents should be observed.

SAMPLING:

1. Collect at least 15 mL urine in an appropriate polypropylene tube or bottle and cap. Refrigerate or freeze immediately after collection. Collect at least two urine specimens for each worker: one before the work shift and one after.
2. Ship the specimens stored in either wet or dry ice in an insulated container. Store frozen upon arrival at the laboratory. A reminder: commercial shippers have special labeling requirements for packages containing dry ice.

SAMPLE PREPARATION:

3. Thaw the urine specimen to room temperature.
4. Mix thoroughly to ensure urine homogeneity.
5. Transfer 2.0 mL of urine into a 16 X 100 mm (or larger) screw-capped culture tube.
6. Acidify by adding 40 µL of concentrated hydrochloric acid.
7. Add 0.5 mL of deionized water.
8. Add 0.5 mL of the 20 µg/mL 3-CPA internal standard solution.
9. Ethyl acetate extraction: Dispense 4 mL of ethyl acetate into the culture tube, cap, and vortex (or vigorously shake) for 1 minute.
10. Allow layers to separate, collect the ethyl acetate (top) layer.

11. Repeat the extraction (steps 9 and 10) three more times. Collect and combine all ethyl acetate extracts using a glass pipet into a 16 X 150 mm culture tube.
12. Dry the ethyl acetate extract by adding approximately 100 to 200 mg of anhydrous magnesium sulfate and swirl for about 15 seconds.
13. Transfer the extract solution into a 16 X 150 mm culture tube by means of a glass funnel with silanized glass wool patch to remove the wet magnesium sulfate. The glass wool patch must be packed tightly enough to prevent particles of magnesium sulfate from passing through.
14. Rinse the tube and the funnel with ethyl acetate to ensure complete transfer.
15. Concentrate the combined ethyl acetate extract for each sample to 1 mL using a nitrogen sweep at room temperature and transfer the solution to a 2-mL GC autosampler vial.
16. tert-Butyldimethylsilane derivatization: Add 50 μ L of MTBSTFA with 1% TBDMCS silanizing reagent to each autosampler vial and cap immediately.
17. Heat the solution for 1.5 hours at 70 $^{\circ}$ C in a heating block or oven.

CALIBRATION AND QUALITY CONTROL:

18. 3-Bromopropionic acid (3-BPA) standards are prepared in blank, non-exposed urine. The 1 mg/mL stock 3-BPA solution is diluted in deionized water to make 0.4, 1, 2, 4, 8, 20, 80, 200, 400, 600, and 800 μ g/mL 3-BPA solutions for spiking.
19. Transfer 2.0 mL of non-exposed urine into a 16 X 100 mm (or larger) screw-capped culture tube.
20. Acidify by adding 40 μ L of concentrated hydrochloric acid.
21. Add 0.5 mL of the 20 μ g/mL 3-CPA internal standard solution.
22. Add 0.5 mL of the appropriate 3-BPA spiking solution described in step 18 to make urine samples equivalent to 0.1, 0.25, 0.5, 1, 2, 5, 20, 50, 100, 150 and 200 μ g/mL of 3-BPA in the original 2.0 mL volume of urine.
23. Prepare at least one blank urine without a 3-BPA spike to verify the source of blank urine contains no detectable quantity of 3-BPA.
24. Prepare at least two levels of quality control (QC) standard of 3-BPA fortified urine using a separately weighed and prepared 3-BPA stock solution. One level should be within the lower 25% of the calibration curve and one level within the upper 25% of the calibration curve. More than two QC levels can be used. QC samples should be analyzed with every batch such that they constitute at least 5% of the sample batch.
25. QC values should be within \pm 20% of the spiked values. If not, the batch is considered out of control, the batch data discarded, and corrective actions should be taken before more samples are analyzed.
26. Ethyl acetate extraction: Prepare the spiked standard urine samples, the blank urine sample(s), and the QC standards the same as described in the preceding Sample Preparation section using Steps 9 through 17.

MEASUREMENT:

27. Set the gas chromatograph according to the manufacturer's recommendations and to the conditions listed on page 8324-1.
28. Set the mass selective detector to selected ion monitoring mode for ions m/z 211 (derivative of 3-BPA) and 165 (derivative of 3-CPA).
NOTE: The use/non-use of qualifier ions for this method is discussed in the literature [9].
29. Inject 0.5 μ L of each sample, standard, blank, and QC standard extract from Steps 17 and 26.
30. Measure the peak areas of the tert-butyldimethylsilane derivatives of 3-BPA and 3-CPA in the chromatograms of the standards.
31. Divide the peak area of the derivative of 3-BPA by the peak area from the derivative of 3-CPA in the same chromatogram.

32. Prepare a linear calibration curve of the peak Area Std./Area Int. Std. versus the concentration of the standard for 3-BPA.
33. Measure the peak areas of the derivatives of 3-BPA and 3-CPA in the remainder of the chromatograms.
34. Divide the peak area of the derivative of 3-BPA by the peak area from the derivative of 3-CPA in the same chromatogram.

CALCULATIONS:

35. Determine the concentration of 3-BPA in the extracts from the original urine (2.0 mL specimen) from the curve obtained in step 32. The results are expressed as $\mu\text{g/mL}$ of 3-BPA in urine.

EVALUATION OF METHOD:

This method was evaluated and described by B'Hymer [6] and in detail by B'Hymer and Cheever [9]. A general summary of this published information is given below:

Accuracy and Precision: Two recovery studies using multiple GC columns over several days demonstrated the accuracy and precision of this test method. The first recovery study was performed over three separate experimental batch runs, and these data are presented in Table 1A. Average recovery was between 93 and 98% for the three 3-BPA spiked level urine samples investigated. For each batch run, the experimental trial consisted of three samples at three different concentration levels. The recovery for each level ($n=9$ samples) is displayed in Table 1A. The second recovery study (data shown in Table 1B) used spiked urine samples from 20 non-exposed volunteers and demonstrated that the procedure was accurate (95% average recovery) and precise (2.5% relative standard deviation.) No interferences were detected in the unspiked urine from the 20 volunteer specimens. Both recovery studies generated a total of 47 spiked urine samples at 2, 10, 20 and 50 $\mu\text{g/mL}$ 3-BPA levels. Precision expressed as percent relative deviation (% RSD) was as high as 5.7% on the 2 $\mu\text{g/mL}$ recovery samples ($n = 9$). Overall recovery was 95% and overall RSD was 3.1% ($n = 47$).

Linearity: All calibration curves used during the development of this method were linear and had correlation coefficients of 0.98 and greater. The concentration range was 0.1 to 200 $\mu\text{g/mL}$ 3-BPA in urine with 2.0 mL urine sample size. Calibration curves were run at the beginning and end of all sample batch runs; calibration curve slope drift was found to be acceptable.

Specificity: The optimized chromatographic conditions developed for this procedure proved to be specific and have no major interferences. The mass spectrometric detector was useful in adding additional specificity to the method. The ion m/z 211 was chosen for monitoring the calibration curve used in the calculations because of its greater abundance, and it was a characteristic fragment for the tert-butyldimethylsilane (TBDMS) derivative of 3-BPA. This is the molecular ion less the tert-butyl group, m/z 57 (Figure 1). Ion m/z 165 was used to monitor the TBDMS derivative of 3-CPA, the internal standard, for the same reasons. Full-scan mass spectra of the TBDMS derivatives are presented in Figure 2. An example chromatogram for blank urine and urine spiked with 3-BPA and 3-CPA is shown in Figure 3.

Robustness: Multiple HP-1 (100% dimethylpolysiloxane) columns of different manufacturing lots were used during the recovery studies. Accuracy and precision did not appear to be affected; therefore, the method appears to be reproducible with any normal functioning HP-1 capillary column. Recovery results from individual urine samples spiked with 3-BPA indicate that the method is accurate and not significantly affected by individual urine sample matrix differences during analyte extraction.

Stability: While sample stability was not exhaustively evaluated, an aqueous stock standard solution of 3-BPA stored for two weeks at 4 °C gave full recovery assay values when compared to a freshly prepared 3-BPA standard. The 3-BPA in the urine specimens appears to be stable in frozen urine for a much

longer time frame of two months or more. Derivatized sample extracts appeared to be stable during a one week time frame.

Range: This method should be considered accurate for the estimation of 3-BPA in human urine within the 2.0 to 100 µg/mL method validation range.

REFERENCES:

- [1] ACGIH [2013]. TLVs and BEIs based on the documentation of the Threshold Limit Values for chemical substances and physical agents and Biological Exposure Indices. Cincinnati, Ohio: American Conference of Governmental Industrial Hygienists. [www.acgih.org] Date accessed: April 2014.
- [2] Commission for the Investigation of Health Hazards of Chemical Compounds in the Work Area [2013]. List of MAK and BAT values 2013; Maximum Concentrations and Biological Tolerance Values at the Workplace. DFG: Deutsche Forschungsgemeinschaft, Wiley-VCH Verlag GmbH & Co. [http://www.dfg.de/en/dfg_profile/publications/senate_commissions/index.html#micro7535782]. Date accessed April 2014.
- [3] SUVA (Swiss National Accident Insurance Fund) [2013]. Protection de la santé au poste de travail. Valeurs limites d'exposition aux postes de travail. [https://www.suva.ch/]. Date accessed: April 2014.
- [4] Institut für Arbeitsschutz der Deutschen Gesetzlichen Unfallversicherung (IFA) [http://www.dguv.de/ifa/GESTIS]. Date accessed: April 2014.
- [5] US FDA [2001]. Guidance for industry: Bioanalytical method validation. U.S. Food and Drug Administration, Washington, DC. [http://www.fda.gov/downloads/Drugs/Guidances/ucm070107.pdf]. Date accessed April 2014.
- [6] B'Hymer C [2004]. 3-Bromopropionic acid in urine, Method 8324. Backup data report.
- [7] Jones AR, Walsh DA [1979]. The oxidative metabolism of 1-bromopropane in the rat. *Xenobiotica* 9(12): 763-772.
- [8] Mathias PI, Cheever KL, Hanley KW, Marlow KL, Johnson BC, B'Hymer C [2012]. Comparison and evaluation of urinary biomarkers for occupational exposure to spray adhesives containing 1-bromopropane. *Toxicol Mech Methods* 22(7): 526-532.
- [9] B'Hymer C, Cheever KL [2004]. Development of a gas chromatographic test for the quantification of the biomarker 3-bromopropionic acid in human urine. *J Chromatogr B* 802: 361-366.
- [10] CDC [2007]. 2007 Guidelines for isolation precautions: preventing transmission of infectious agents in healthcare settings. [http://www.cdc.gov/hicpac/2007IP/2007isolationprecautions.html]. Date accessed: April 2013.

METHOD WRITTEN BY:

Clayton B'Hymer, PhD, NIOSH/DART/BHAB. Final editing performed by Dale A. Shoemaker, PhD, NIOSH/DART/CEMB.

Disclaimer: Mention of any company or product does not constitute endorsement by NIOSH. In addition, citations to websites external to NIOSH do not constitute NIOSH endorsement of the sponsoring organizations or their programs or products. Furthermore, NIOSH is not responsible for the content of these websites. All web addresses referenced in this document were accessible as of the publication date.

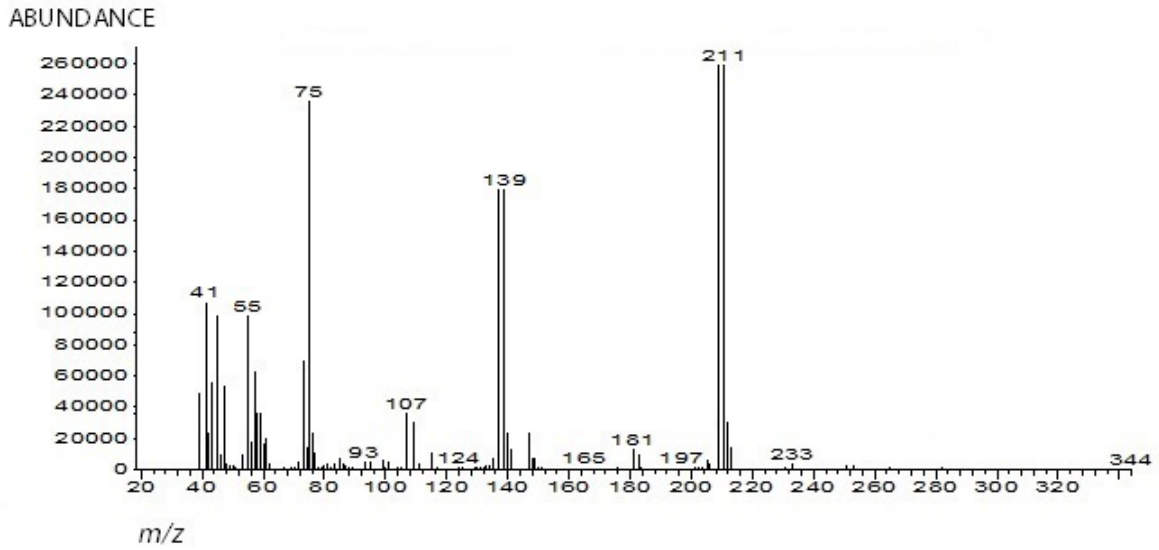

Figure 2a. Mass spectrum for 3-Bromopropionic acid, t-butyltrimethylsilyl ester

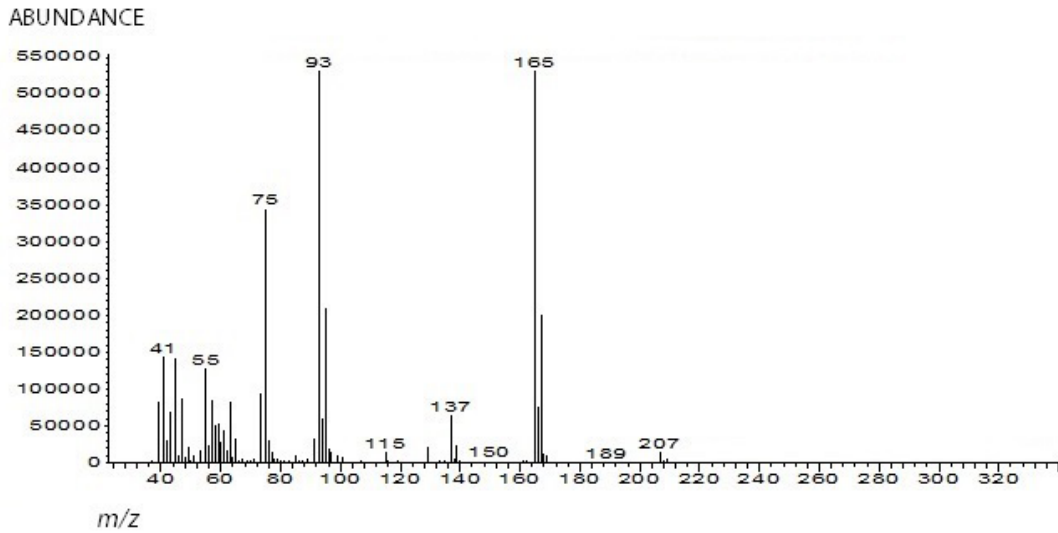

Figure 2b. Mass spectrum for 3-Chloropropionic acid, t-butyltrimethylsilyl ester

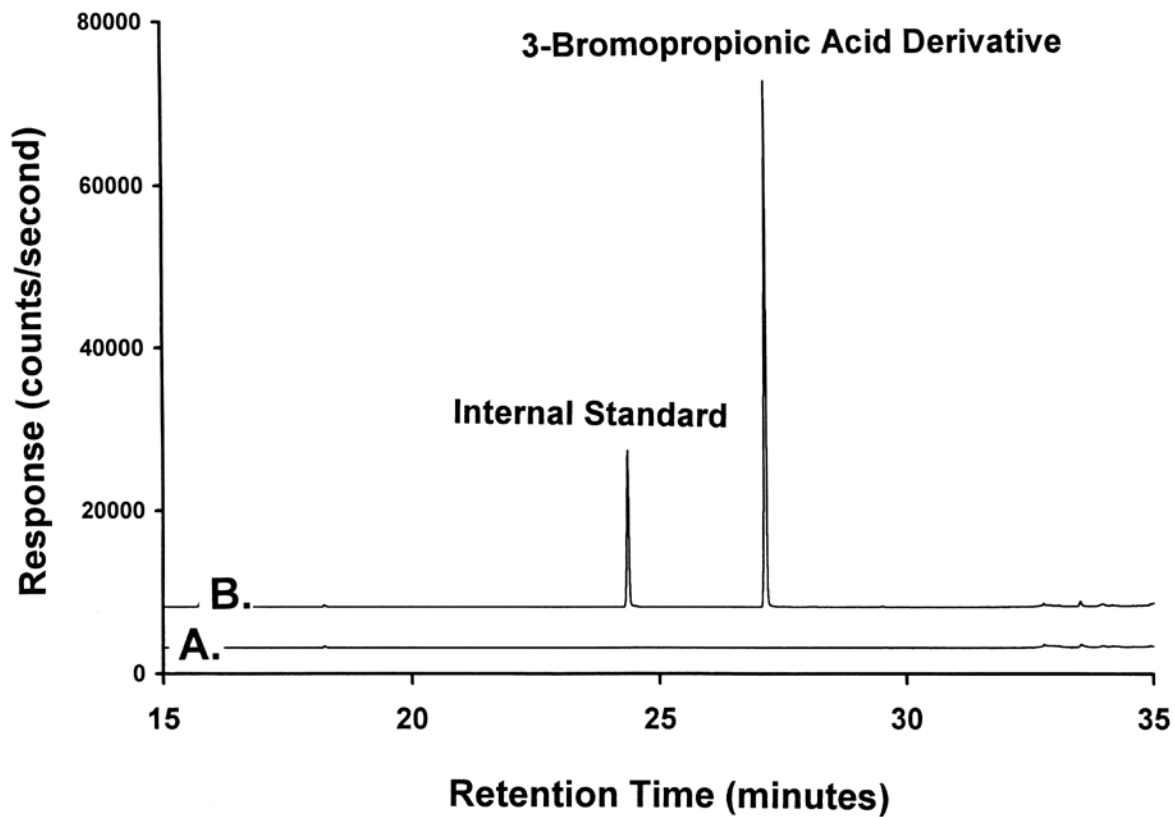

Figure 3. A total ion chromatogram of a (A) blank non-exposed volunteer urine specimen and (B) 20 µg/mL spiked 3-BPA urine solution with 5 µg/mL equivalent 3-CPA as the internal standard. No interfering peaks were evident in any of the group of 20 non-exposed volunteer specimens.

Table 1. Recovery studies of 3-bromopropionic acid:
(A) multilevel recovery study of 3-BPA from spiked urine samples¹,
(B) recovery of 20 µg/mL 3-BPA spikes from individual urines of 20 non-exposed volunteers²
Note: Overall recovery of all samples was 95% and overall RSD was 3.1% (n = 47.)

(A)

| Spike level (µg/mL) | Mean 3-BPA recovered, (n = 9, µg/mL) | Average % Recovery | Standard Deviation (µg/mL) | % Relative Standard Deviation |
|---------------------|--------------------------------------|--------------------|----------------------------|-------------------------------|
| 2 | 1.91 | 96 | 0.11 | 5.7 |
| 10 | 9.32 | 93 | 0.13 | 1.4 |
| 50 | 48.9 | 98 | 0.36 | 0.7 |

(B)

| Volunteer urine Spike level (µg/mL) | Mean 3-BPA recovered (n = 20, µg/mL) | Average % Recovery | Standard Deviation (µg/mL) | % Relative Standard Deviation |
|-------------------------------------|--------------------------------------|--------------------|----------------------------|-------------------------------|
| 20 | 19.0 | 95 | 0.48 | 2.5 |

¹ Three different spiked urine samples were prepared at each level and chromatographed on three separate experimental trial runs (a total of nine samples at each spike level were analyzed.)

² All non-spiked specimens showed no 3-BPA derivative peak in the chromatograms.



S-Benzylmercapturic acid and S-phenylmercapturic acid in urine

8326

Metabolites of toluene and benzene

| | | | |
|------------------------------|--|-----------|-----------------|
| 1. S-Benzylmercapturic acid: | FORMULA: C ₁₂ H ₁₅ NO ₃ S | MW: 253.3 | CAS: 19542-77-9 |
| 2. S-Phenylmercapturic acid: | FORMULA: C ₁₁ H ₁₃ NO ₃ S | MW: 239.3 | CAS: 20640-68-0 |

METHOD: 8326, Issue 1 **EVALUATION:** Full **Issue 1:** 20 May 2014

Published limits and guidelines using these compounds as markers:

- 1. Toluene: OSHA and NIOSH: None
- 2. Benzene: OSHA and NIOSH: None

Other OELs: Because data on exposure limits and guidelines may change over time, NIOSH recommends referring to the following sources for updated limits and guidelines concerning the use of these compounds as markers for toluene and benzene [1- 4].

PROPERTIES: 1. Solid; density =1.246 g/cm³; mp 162-163 °C
2. Solid; density = 1.28 g/cm³; mp 155 °C

BIOLOGICAL

INDICATOR OF: Exposure to 1. toluene and
2. benzene

SYNONYMS (not all inclusive):

- 1. S-Benzylmercapturic Acid (BMA): S-benzyl-N-acetyl-L-cysteine; (2R)-2-Acetamido-3-(phenylmethylsulfanyl)propanoic acid; Alanine, N-acetyl-3-(benzylthio)-; S-phenylmethyl-N-acetyl-L-cysteine
- 2. S-Phenylmercapturic acid (PMA): S-phenyl-N-acetyl-L-cysteine; (2R)-2-Acetamido-3-(phenylsulfanyl)propanoic acid; (2R)-2-Acetylamino-3-(phenylthio)propionic acid

| SAMPLING | MEASUREMENT |
|--|--|
| <p>SPECIMEN: Urine</p> <p>VOLUME: At least 8 mL</p> <p>PRESERVATIVE: None added. Refrigerate or freeze upon collection.</p> <p>SHIPMENT: Ship cold or frozen with ice or dry ice. Freeze upon receipt at the laboratory.</p> <p>SAMPLE STABILITY: Stable in frozen urine for periods of a month or more and for several freeze/thaw cycles [5,6].</p> <p>CONTROLS: Urine specimens obtained from non-exposed or low level exposed individuals.</p> | <p>TECHNIQUE: HIGH-PERFORMANCE LIQUID CHROMATOGRAPHY - TANDEM MASS SPECTROMETRY (HPLC/MS/MS)</p> <p>ANALYTES: S-Benzylmercapturic acid and S-phenylmercapturic acid</p> <p>EXTRACTION: Solid-Phase Extraction (SPE) C18</p> <p>COLUMN: C18 [dimethyloctadecylsilane solid phase type, 3.5 µm particle size] (150 mm by 3 mm)</p> <p>MOBILE PHASES: A = 5/95/0.1% (v/v/v) acetonitrile/water/acetic acid B = 75/25/0.1% (v/v/v) acetonitrile/water/acetic acid</p> <p>FLOW RATE: 0.3 mL/min (0.4 mL/min post run)</p> <p>GRADIENT: Time (min) vs. Mobile Phase Composition 0 to 10 0 to 40% B 10 to 18 40 to 100% B 18 to 20 100% B 20 to 21 100% B Flow increased to 0.4 mL/min 21 to 28 100% B (0.4 mL/min flow) 28 to 30 100 to 0% B (re-equilibration, 0.3 mL/min) 30 to 37 0% B (re-equilibration)</p> <p>INJECTION VOLUME: 8 µL</p> <p>IONIZATION SOURCE: Electrospray at 3500 Volts and negative scan mode, nebulizer gas at 35 psi and 10 L/min flow</p> <p>DETECTOR (MS/MS): Dwell time = 200 msec; Fragmentor at 80 Volts; Collision energy at 8 Volts; Collision gas: nitrogen at 0.06 L/min</p> <p>MULTIPLE REACTION MODE: Quantification mass transitions; BMA = m/z 252 → 123, PMA = 238 → 109, d₅-BMA = 257 → 128, d₅-PMA = 243 → 114</p> <p>TOTAL RUN TIME: Approximately 37 minute cycle time</p> <p>CALIBRATION: BMA and PMA solutions with internal standards</p> <p>QUALITY CONTROL: At least one level of spiked urine specimen prepared from a separately weighed stock solution</p> <p>RANGE: 0.5 to 50 ng/mL for BMA and PMA</p> <p>ESTIMATED LOD: Approximately 0.2 ng/mL for BMA and PMA; by lowest standard levels, BMA and PMA = 0.5 ng/mL</p> <p>PRECISION (\bar{S}_r): See Table 2</p> |
| ACCURACY* | |
| <p>RANGE STUDIED: See Table 2</p> <p>BIAS: Negligible</p> <p>OVERALL PRECISION (\hat{S}_{rT})*: See Table 2</p> <p>ACCURACY*: Overall recoveries obtained from spiked urine samples (n=48) were 103% and 106% for S-benzylmercapturic acid and S-phenylmercapturic acid, respectively. The precision as relative standard deviation was no greater than 5.0% at any concentration level (n=9, Table 2).</p> | |

* The definitions of precision and accuracy in this method are those utilized by the US Food and Drug Administration [7].

APPLICABILITY: BMA and PMA are metabolites of toluene and benzene, respectively. PMA is a very specific biomarker for benzene. BMA can form from exposure to other sources, such as benzyl acetate or benzyl alcohol which can be found in personal care products [8]. Both toluene and benzene are common solvents with multiple occupational uses; furthermore exposure to toluene and benzene (less commonly) can occur from environmental and other sources. This method measures the quantity of the two target metabolite analytes in urine.

INTERFERENCES: None found or identified.

OTHER METHODS: This method is based on the research of B'Hymer [9,10]. There are numerous literature methods for these two compounds, but standardized methods from governmental agencies or consensus standards organizations are not currently available, though there is also a recent method developed at CDC/National Center for Environmental Health for these analytes and others [11].

REAGENTS:

1. S-Benzylmercapturic acid (BMA, *N*-acetyl-S-benzyl-DL-cysteine, CAS no. 19542-77-9) reference standard 0.20 mg/mL stock solution in methanol. Store at 4 °C in amber vials (or in the dark).
2. S-Phenylmercapturic acid (PMA, phenyl-*N*-acetyl-DL-cysteine, CAS no. 20640-68-0) reference standard 0.20 mg/mL stock solution in methanol. Store at 4 °C in amber vials (or in the dark).
3. Deuterated S-benzyl-d₅-mercapturic acid reference standard (d₅-BMA), 0.15 mg/mL stock solution in methanol. Store at 4 °C in amber vials (or in the dark).
4. Deuterated S-phenyl-d₅-mercapturic acid reference standard (d₅-PMA), 0.15 mg/mL stock solution in methanol. Store at 4 °C in amber vials (or in the dark).
5. Internal standard spiking solution, deuterated stock solutions diluted to approximately 30 ng/mL in water
6. Acetone, HPLC grade or better*
7. Acetonitrile, HPLC grade or better*
8. Acetic Acid, glacial, ACS reagent grade or better*
9. Methanol, HPLC grade or better*
10. Water, doubly deionized, minimum resistivity of 18 MΩ-cm
11. Water, HPLC grade
12. Acetonitrile/water (50/50%, v/v) injector rinse solution
13. Chromatographic matrix adjustment solution, 49/50/1% (v/v/v) acetonitrile/water/acetic acid
14. Mobile phase A (5/95/0.1%, v/v/v) acetonitrile/water/acetic acid, filtered through 0.7 µm glass microfiber filters
15. Mobile phase B (75/25/0.1%, v/v/v) acetonitrile/water/acetic acid, filtered through 0.7 µm glass microfiber filters
16. Synthetic urine substitute, if desired
17. Nitrogen, UHP

* See SPECIAL PRECAUTIONS*

EQUIPMENT:

1. High-Performance Liquid Chromatograph (HPLC) equipped with a tandem mass spectrometric detector with data collection system, page 8326-1
2. HPLC column (C18 [dimethyloctadecylsilane solid phase type], 150 mm X 3 mm, 3.5 µm particle size)
3. Autosampler
4. Analytical balance, 0.1 mg readability
5. Rotary vacuum concentrator with cold trap and vacuum pump or analytical evaporator with nitrogen
6. Automatic pipet with disposable tips in the 1000 µL volume delivery range
7. Solid-phase extraction (SPE) cartridges, C18, 500 mg, 3 mL
8. SPE vacuum manifold apparatus
9. Culture tubes, disposable screw-top (16 X 150 mm) with PTFE-lined caps
10. Tubes, polypropylene, disposable screw-top, 15 mL. Polypropylene bottles and caps may also be used for sample collection.
11. Metal spatula
12. Volumetric flasks: 10, 50, 100 and 200 mL
13. Autosampler vials, amber, with caps and septa
14. Disposable glass pipets
15. Sintered glass filtration apparatus and 1-L side-armed Erlenmeyer flask
16. Microfiber filters, glass, 0.7 µm; diameter to fit the filtration apparatus
17. Wet or dry ice

SPECIAL PRECAUTIONS: Standard precautions should always be used when handling bodily fluids and/or extracts of bodily fluids [12]. Handle urine specimens and urine extracts using powder-free latex or nitrile gloves. Acetic acid, acetone, acetonitrile and methanol are flammable; handle with care and use in a chemical fume hood. Handle all chemicals using the required safety precautions. Reagents with manufacturer expiration dates should be observed.

SAMPLING:

1. Collect at least 8 mL of urine in an appropriate polypropylene tube or bottle and cap. Refrigerate at 4 °C or freeze after collection. Collect at least two urine specimens for each worker, one before the work shift and one after.
2. Ship the specimen stored in either wet or dry ice in an insulated container. Freeze specimens upon arrival at the laboratory and store frozen. A reminder: commercial shippers have special labeling requirements for packages containing dry ice.

SAMPLE PREPARATION:

NOTE: BMA and PMA are somewhat light sensitive (see Evaluation of Method section). Perform the sample preparation steps in a low light environment. Extreme measures are not required.

3. Thaw the urine specimen to room temperature.
4. Mix urine specimen thoroughly to ensure homogeneity.
5. Transfer 4.0 mL of urine into a 16 X 150 mm (or larger) screw-capped culture tube.
6. Add 0.5 mL of deionized water to aid in the dissolution of solids.
7. Add 0.5 mL of the 30 ng/mL deuterated BMA/PMA internal standard solution.

8. Solid-phase extraction

NOTE: All SPE steps are performed using the vacuum manifold apparatus. The flow rate should not exceed 1 mL/min. The SPE cartridges should not be allowed to go to dryness until the end of Step 8d. Refer to manufacturers' recommendations for use of specific SPE cartridges.

- a. Pre-wash the C18 SPE cartridge with 2 mL of acetone.
 - b. Equilibrate the SPE cartridge with 2 mL of HPLC grade water.
 - c. Load the 5-mL urine mixture and draw the sample through the cartridge.
 - d. Wash the cartridge with 1 mL of HPLC grade water. Discard any liquid collected up to this point.
 - e. Apply (or increase) the vacuum to pull most of the water from the cartridge.
 - f. Elute the analytes with 3 mL of acetone three times, collecting all of the acetone washes into a 15-mL plastic screw-capped tube.
9. Evaporate the 9 mL of acetone from the extracts to dryness by means of a vacuum rotary concentrator or by using a nitrogen sweep.
 10. Cap the plastic tubes containing the dry extract and store in a refrigerator/freezer until ready for chromatographic analysis.
 11. Prior to chromatographic analysis, dissolve the extract in 1 mL of HPLC mobile phase A and transfer the sample into an amber HPLC autosampler vial.

CALIBRATION AND QUALITY CONTROL:

12. Prepare a BMA/PMA standard mixture by combining 2.0 mL of each stock solution and diluting to 100 mL with deionized water to make an approximately 4 µg/mL solution concentration for each.
13. BMA/PMA standard solutions: The 4 µg/mL BMA/PMA solution is diluted in water to make 4, 8, 16, 40, 80, 320 and 400 ng/mL BMA/PMA solutions.
14. Accurately transfer 0.500 mL of each BMA/PMA solution from step 13 into a separate HPLC autosampler vial. [This delivers 2, 4, 8, 20, 40, 160 and 200 ng of each analyte to each autosampler vial.]
15. Add 0.5 mL of the deuterated internal standard spiking solution [30 ng/mL] to each vial. [This delivers 15 ng of the internal standards to each autosampler vial.]

16. Add 0.1 mL of the chromatographic matrix adjustment solution to each standard vial.
NOTE: These standard samples are *equivalent* to 0.5 to 50 ng/mL BMA/PMA urine samples [based on the original 4.0 mL urine volume extracted and placed in each autosampler vial.]
17. Prepare one blank urine sample without analyte spikes; alternatively, prepare one blank using a urine substitute by following steps 14-16 using 0.5 mL of the unspiked urine or substitute in step 14.
18. Prepare at least one quality control (QC) standard of urine or urine substitute fortified with PMA/BMA using separately prepared stock solutions. A 10 ng/mL equivalent spike level is suggested and more than one level can be used if desired.

MEASUREMENT:

19. Set the high-performance liquid chromatograph according to the manufacturer's recommendations and to the conditions listed on page 8326-1. A needle rinse with 50/50% (v/v) acetonitrile/water is required to eliminate sample carry-over by the autosampler.
20. Set the mass spectrometric detector to multiple reaction mode (MRM) according to the manufacturer's recommendations and the conditions listed on page 8326-1. Example conditions are summarized below:

Table 1. MS/MS Conditions using negative electrospray ionization

| Analyte | Precursor Ion | MS1 Resolution | Product Ion | MS2 Resolution | Dwell Time (msec) | Fragmentor Voltage | Collision Energy (volt) |
|---------------------|---------------|----------------|-------------|----------------|-------------------|--------------------|-------------------------|
| d ₅ -BMA | 257 | unit | 128 | unit | 200 | 80 | 8 |
| BMA | 252 | unit | 123 | unit | 200 | 80 | 8 |
| d ₅ -PMA | 243 | unit | 114 | unit | 200 | 80 | 8 |
| PMA | 238 | unit | 109 | unit | 200 | 80 | 8 |

21. Inject 8 µL of each sample extract, standard, QC standard, and blank. Sample chromatograms for each compound are illustrated in Figure 1.
22. Measure the peak areas of the two analytes (BMA and PMA) and those for the deuterated internal standards (d₅-BMA and d₅-PMA) in the chromatograms. Divide the peak area of the analytes by the peak area from the matching deuterated internal standard.
23. Prepare calibration curves of the peak Area Std./Area Internal Std. (ratio calculated in step 22) versus the *urine equivalent* concentration of the standards for the two analytes.

CALCULATIONS:

24. Determine the concentration of the two analytes in the extracts from the original urine (4.0 mL specimen) from the curves obtained in step 23. The results can be expressed as ng/mL of each analyte in urine.

EVALUATION OF METHOD:

This method was evaluated and described in detail by B'Hymer [9,10]. A general summary of this published information is given below:

Accuracy and Precision. Three recovery studies using multiple columns over several days demonstrated the accuracy and precision of this test method. The first recovery study was performed using fortified urine samples over three separate experimental batch runs, and these data are presented in Table 2. Average recoveries were between 102 and 106% for the two analytes over the four spiked

concentration levels investigated. For each batch run, the experimental trial consisted of three samples at four different concentration levels. The recovery and precision for each level ($n = 9$ samples) are displayed in Table 2. The relative standard deviations (RSD) observed ranged from 2.0 to 5.0%. These accuracy and precision numbers fall well within parameters established for bioanalytical methods [7].

The second recovery study was performed using a urine substitute, fortified over three separate experimental batch runs, and these data are presented in Table 3. Average recoveries were between 99 and 109% for the two analytes over the four spiked concentration levels investigated. For each batch run, the experimental trial consisted of three samples at four different concentration levels. The recovery for each level ($n = 9$ samples) is displayed in Table 3. As seen in the RSD column of Table 3, precision was much worse for the urine substitute recovery study. This is due to a higher level of ion suppression in the electrospray source. This was especially pronounced at the lower spiked concentration levels (1 and 2 ng/mL). The highest result for the RSD of the 9 samples fortified at 1 ng/L BMA was 29%. While the accuracy numbers meet standard criteria, the precision values at the lower concentrations do not [7]. The use of a urine substitute for QC samples is not recommended for this method.

The third recovery study used urine specimens from twelve non-exposed volunteers; six were smokers and six were non-smokers. Most participants' specimens had base levels for both BMA and PMA as are shown in Table 4. Again, reasonable accuracy and precision were demonstrated for a 6 ng/mL equivalent level spike; individual recoveries ranged from 95 to 109% for BMA and 101 to 123% for PMA (Table 4). No interferences were detected in the unspiked urine from the 12 volunteer specimens. This study illustrates two important points: 1. Levels of both metabolites can be found in the urine of non-exposed individuals, which is why aqueous standards are used in this method, and 2. It is important to ascertain smoking status and other non-occupational exposures that may cause elevated levels of these metabolites.

Linearity. All calibration curves used during the development of this method were linear and had correlation coefficients of 0.99 and greater. The concentration range was equivalent to 0.5 to 50 ng/mL BMA and PMA for the extraction of 4.0 mL urine. Calibration curves were run at the beginning and end of all sample batch runs; calibration curve slope drift was found to be minimal.

Specificity. The optimized chromatographic conditions developed for this method, along with the tandem mass spectrometric detector, proved to be specific and showed no major interferences. The mass transition ions of BMA and PMA chosen in this method had the greatest response and were the predominant daughter ions.

Robustness. Two C18 HPLC columns (Zorbax Rx-C18, Agilent Technologies, Santa Clara, CA, USA) from the same manufacturer but from different manufacturing lots were used during the recovery studies. Accuracy and precision were not affected; therefore, the method was found to be reproducible with any normal functioning C18 HPLC column. Recovery results from individual volunteer urine specimens spiked with the analytes indicate that the method is accurate and not significantly affected by individual urine specimen matrix differences during analyte extraction. The urine substitute was found to cause problems with precision, especially at lower levels; this was attributed to an increase in ion suppression over human urine within the electrospray source.

Stability. Sample stability was evaluated, whereby a six-day stability study was conducted on the final chromatographic sample solution. BMA and PMA were stable at 8 °C (the autosampler temperature) and at room temperature in the absence of light. A light stability experiment was carried out by storing this solution in a clear glass vial at room temperature on the window sill, thus creating a worst-case scenario. After 1 day of storage in light under these conditions, BMA and PMA had mean assay values of 75 and 72% ($n = 3$), respectively, when compared to solutions of freshly prepared reference standards. After three days of light exposure, extensive degradation was noticed; BMA mean assay values had fallen to 9% ($n = 3$) of the original level and PMA had fallen to 16% ($n = 3$). After six days of exposure to light, both analytes were nearly completely degraded. Although both analytes benefit from the use of

individual deuterated internal standards, the use of amber glass autosampler vials or other means of reducing light exposure is recommended to ensure sample stability during extended chromatographic batch runs.

Range. This method should be considered accurate for the estimation of BMA and PMA in human urine within the 0.5 to 50 ng/mL standard curve range. Field samples at higher levels can be diluted to a concentration within that range for analysis.

REFERENCES:

- [1] ACGIH [2013]. TLVs and BEIs based on the documentation of the Threshold Limit Values for chemical substances and physical agents and Biological Exposure Indices. Cincinnati, Ohio: American Conference of Governmental Industrial Hygienists. [www.acgih.org]. Date accessed: April 2014.
- [2] Commission for the Investigation of Health Hazards of Chemical Compounds in the Work Area [2013]. List of MAK and BAT values 2013; Maximum Concentrations and Biological Tolerance Values at the Workplace. DFG: Deutsche Forschungsgemeinschaft, Wiley-VCH Verlag GmbH & Co. [http://www.dfg.de/en/dfg_profile/publications/senate_commissions/index.html#micro7535782]. Date accessed April 2014.
- [3] SUVA (Swiss National Accident Insurance Fund) [2013]. Protection de la santé au poste de travail. Valeurs limites d'exposition aux postes de travail. [https://www.suva.ch/]. Date accessed: April 2014.
- [4] Institut für Arbeitsschutz der Deutschen Gesetzlichen Unfallversicherung (IFA) [http://www.dguv.de/ifa/GESTIS]. Date accessed: April 2014.
- [5] Boogaard PJ, Van Sittert NJ [1995]. Biological monitoring of exposure to benzene: A comparison between S-phenylmercapturic acid, *trans, trans*-muconic acid and phenol. *Occup Environ Med* 52:611-620.
- [6] Schettgen T, Musiol A, Kraus T [2008]. Fast determination of urinary S-phenylmercapturic acid and S-benzylmercapturic acid by column-switching liquid chromatography-mass spectrometry. *J Chromatogr B* 863:283-292.
- [7] FDA [2001]. Guidance for industry: Bioanalytical method validation, U.S. Food and Drug Administration, Rockville, MD. [http://www.fda.gov/downloads/Drugs/Guidances/ucm070107.pdf]. Date accessed April 2014.
- [8] Lovreglio P, Barbieri A, Carrieri M, Sabatini L, Fracasso ME, Doria D, Drago I, Basso A, D'Errico MN, Bartolucci GB, Violante FS, Soleo L [2010]. Validity of new biomarkers of internal dose for use in the biological monitoring of occupational and environmental exposure to low concentrations of benzene and toluene. *Int Arch Occup Environ Health* 83:341-356.
- [9] B'Hymer C [2011]. Backup data report for method no. 8326: S-benzylmercapturic acid and S-phenylmercapturic acid in urine.
- [10] B'Hymer C [2011]. Validation of an HPLC-MS/MS method for the determination of urinary S-benzylmercapturic acid and S-phenylmercapturic acid. *J Chromatogr Sci* 49:547-553.
- [11] Alwis KU, Blount BC, Britt AS, Patel D, Ashley DL [2012]. Simultaneous analysis of 28 urinary VOC metabolites using ultra high performance liquid chromatography coupled with electrospray ionization tandem mass spectrometry (UPLC-ESI/MS-MS). *Anal Chim Acta* 750:152-160.
- [12] CDC [2007]. 2007 Guidelines for isolation precautions: Preventing transmission of infectious agents in healthcare settings. [http://www.cdc.gov/hicpac/2007IP/2007isolationprecautions.html]. Date accessed: April 2014.

METHOD WRITTEN BY:

Clayton B'Hymer, Ph.D., NIOSH/DART/BHAB. Final editing performed by Dale A. Shoemaker, Ph.D., NIOSH/DART/CEMB.

Disclaimer: Mention of any company or product does not constitute endorsement by NIOSH. In addition, citations to websites external to NIOSH do not constitute NIOSH endorsement of the sponsoring organizations or their programs or products. Furthermore, NIOSH is not responsible for the content of these websites. All web addresses referenced in this document were accessible as of the publication date.

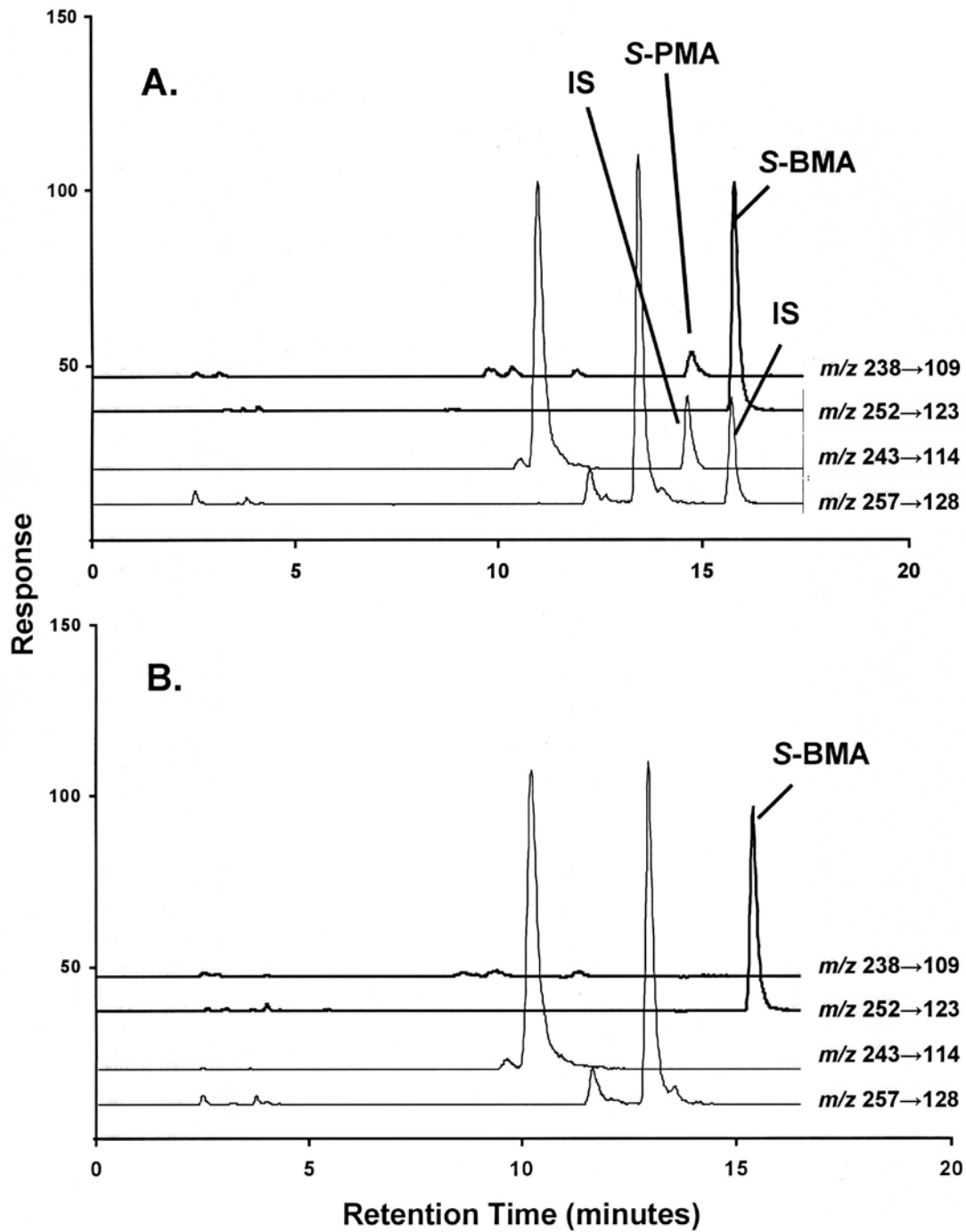

Figure 1. Chromatograms obtained using the described procedure: (A) fortified urine containing 1 ng/mL S-PMA, 7.2 ng/mL S-BMA, and 3.8 ng/mL of each of the deuterated internal standards (IS) and (B) non-fortified urine from above containing only the background level of 6.2 ng/mL S-BMA

Table 2. Multiple level recovery experiment of BMA and PMA from urine

| Analyte | Analyte added (ng/mL) | Mean concentration (ng/mL, n = 9) | Mean background corrected concentration (ng/mL, n = 9) | Average recovery (%) | Standard deviation (ng/mL) | %RSD ¹ |
|------------------|-----------------------|-----------------------------------|--|----------------------|----------------------------|-------------------|
| BMA ² | 1 | 7.43 | 7.18 | 103 | 0.37 | 5.0 |
| BMA ² | 2 | 8.44 | 8.18 | 103 | 0.19 | 2.3 |
| BMA ² | 8 | 14.6 | 14.2 | 103 | 0.32 | 2.2 |
| BMA ² | 30 | 38.2 | 36.2 | 106 | 0.94 | 2.4 |
| PMA | 1 | 1.02 | 1.00 | 102 | 0.05 | 4.9 |
| PMA | 2 | 2.10 | 2.00 | 105 | 0.09 | 4.3 |
| PMA | 8 | 8.23 | 8.00 | 103 | 0.27 | 3.3 |
| PMA | 30 | 31.9 | 30.0 | 106 | 0.65 | 2.0 |

Notes: 1. %RSD = percent relative standard deviation

2. The non-fortified reference urine had a background level of 6.2 ng/mL BMA and no detectable level of PMA.

Three different spiked samples were prepared at each level and analyzed during three separate experimental trial runs (a total of nine samples at each spike level were analyzed). The same C18 column was used for experimental batch trials 1 and 2; a second C18 column was used on trial run 3.

Table 3. Multiple level recovery experiment of BMA and PMA from a urine substitute

| Analyte | Analyte added (ng/mL) | Mean concentration (ng/mL, n = 9) | Average recovery (%) | Standard deviation (ng/mL) | %RSD ¹ |
|---------|-----------------------|-----------------------------------|----------------------|----------------------------|-------------------|
| BMA | 1 | 1.07 | 107 | 0.31 | 29 |
| BMA | 2 | 2.13 | 106 | 0.34 | 16 |
| BMA | 8 | 8.31 | 104 | 0.53 | 6.4 |
| BMA | 30 | 30.7 | 102 | 0.76 | 2.5 |
| PMA | 1 | 1.09 | 109 | 0.27 | 25 |
| PMA | 2 | 1.98 | 99 | 0.16 | 7.9 |
| PMA | 8 | 7.96 | 100 | 0.48 | 6.0 |
| PMA | 30 | 31.1 | 104 | 0.91 | 2.9 |

Notes: 1. %RSD = percent relative standard deviation.

Three different spiked samples were prepared at each level and analyzed during three separate experimental trial runs (a total of nine samples at each spike level were analyzed).

Table 4. Individual smoker and non-smoker recovery experiment of BMA and PMA

| Individual Sample | Background Level | | Fortified Urine (background + 6 ng/mL) | | Fortified Urine Recovery | |
|-------------------|------------------|-------------|---|-------------|--------------------------|-----------------------|
| | BMA (ng/mL) | PMA (ng/mL) | BMA (ng/mL) | PMA (ng/mL) | BMA [ng/mL (percent)] | PMA [ng/mL (percent)] |
| Smoker 1 | 2.7 | 0.2 | 8.7 | 6.2 | 8.6 (99%) | 6.5 (104%) |
| Smoker 2 | 28.3 | 0.3 | 34.3 | 6.3 | 34.7 (101%) | 6.9 (108%) |
| Smoker 3 | 15.9 | 0.9 | 21.9 | 6.9 | 21.3 (97%) | 7.9 (114%) |
| Smoker 4 | 5.7 | 0.3 | 11.7 | 6.3 | 11.6 (99%) | 7.7 (121%) |
| Smoker 5 | 1.3 | nd | 7.3 | 6.0 | 6.9 (95%) | 6.4 (106%) |
| Smoker 6 | 9.2 | 0.7 | 15.2 | 6.7 | 15.5 (102%) | 7.0 (104%) |
| Mean | 10.5 | 0.4 | 16.5 | 6.4 | 16.4 (99%) | 7.1 (110%) |
| Non-smoker 1 | 0.3 | nd | 6.3 | 6.0 | 6.2 (98%) | 6.2 (103%) |
| Non-smoker 2 | 7.1 | nd | 13.1 | 6.0 | 14.3 (109%) | 7.4 (123%) |
| Non-smoker 3 | 6.8 | nd | 12.8 | 6.0 | 13.1 (102%) | 6.8 (112%) |
| Non-smoker 4 | 23.3 | nd | 29.3 | 6.0 | 28.6 (97%) | 6.3 (105%) |
| Non-smoker 5 | 4.7 | nd | 10.7 | 6.0 | 11.0 (103%) | 6.3 (105%) |
| Non-smoker 6 | 7.2 | nd | 13.2 | 6.0 | 13.5 (102%) | 6.1 (101%) |
| Mean | 8.2 | - | 14.2 | 6.0 | 14.5 (102%) | 6.5 (108%) |

Notes: The instrumental limit of detection (LOD) was estimated to be approximately 0.2 ng/mL for both analytes. The lowest standard value was 0.5 ng/mL for both analytes. [Values near the LOD were reported to one significant figure.]
 nd = none detected (< 0.2 ng/mL)

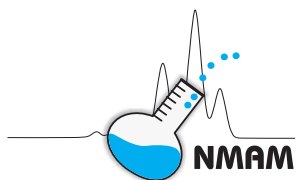

ASBESTOS, CHRYSOTILE by XRD

9000

$Mg_3Si_2O_5(OH)_4$ MW: ~283 CAS: 12001-29-5 RTECS: CI6478500

METHOD: 9000, Issue 3

EVALUATION: FULL

Issue 1: 15 May 1989

Issue 3: 20 October 2015

EPA Standard (Bulk): 1% by weight

PROPERTIES: Solid, fibrous mineral; conversion to forsterite at 580 °C; attacked by acids; loses water above 300 °C

SYNONYMS: Chrysotile

| SAMPLING | MEASUREMENT |
|---|--|
| <p>BULK SAMPLE: 1 g to 10 g</p> <p>SHIPMENT: Seal securely to prevent escape of asbestos</p> <p>SAMPLE STABILITY: Indefinitely</p> <p>BLANKS: None required</p> | <p>TECHNIQUE: X-RAY POWDER DIFFRACTION</p> <p>ANALYTE: Chrysotile</p> <p>PREPARATION: Grind under liquid nitrogen; wet-sieve through 10 µm sieve</p> <p>DEPOSIT: 5 mg dust on 0.45 µm silver membrane filter</p> |
| ACCURACY | <p>XRD: Copper target X-ray tube; optimize for intensity; 1° slit; integrated intensity with background subtraction</p> <p>CALIBRATION: Suspensions of asbestos in 2-propanol</p> <p>RANGE: 1% to 100% asbestos</p> <p>ESTIMATED LOD: 0.2% asbestos in talc and calcite; 0.4% asbestos in heavy X-ray absorbers such as ferric oxide</p> <p>PRECISION (\bar{S}): 0.07 (5% to 100% asbestos); 0.10 (@ 3% asbestos); 0.125 (@ 1% asbestos)</p> |
| <p>RANGE STUDIED: 1% to 100% in talc [1]</p> <p>BIAS: Negligible if standards and samples are matched in particle size [1]</p> <p>OVERALL PRECISION (\hat{S}_{rr}): Unknown; depends on matrix and concentration</p> <p>ACCURACY: ±14% to ±25%</p> | |

APPLICABILITY: Analysis of percent chrysotile asbestos in bulk samples.

INTERFERENCES: Antigorite (massive serpentine), chlorite, kaolinite, bementite, and brushite interfere. X-ray fluorescence and absorption is a problem with some elements; fluorescence can be circumvented with a diffracted beam monochromator, and absorption is corrected for in this method.

OTHER METHODS: This is NIOSH method P&CAM 309 [2] applied to bulk samples only, since the sensitivity is not adequate for personal air samples. An EPA test method for the determination of asbestos in bulk insulation samples is similar to this one [3]. NIOSH method 7400 is an optical counting procedure for airborne fibers in personal samples. NIOSH methods 7402 (Asbestos by Transmission Electron Microscopy) and 9002 (Asbestos by Polarized Light Microscopy) are also useful for positive identification of asbestos.

REAGENTS:

1. Chrysotile,* certified reference material.
2. 2-Propanol.*
3. Desiccant.
4. Glue or tape for securing silver filters to XRD holders.

*See SPECIAL PRECAUTIONS.

EQUIPMENT:

1. Vials, plastic (for bulk sample).
2. Freezer mill, liquid nitrogen-cooled, grinding vials, and extractor.
3. Ultrasonic bath.
4. Sieve, 10 μm , for wet-sieving.
5. Filters, polycarbonate, 1.0 μm , 37 mm.
6. Filtration apparatus and side-arm vacuum flask with 25 mm and 37 mm filter holders.
7. Oven, drying, 110 $^{\circ}\text{C}$.
8. Analytical balance, readable to 0.01 mg.
9. Beaker, Griffin, 50 mL, with watch glass cover.
10. Filters, silver membrane, 25 mm diameter, 0.45 μm pore size.
11. Desiccator.
12. Bottles, glass, 1 L, with ground glass stoppers.
13. Wash bottle, polyethylene.
14. Magnetic stirrer.
15. X-ray powder diffractometer with copper target X-ray tube and scintillation detector.
16. Reference specimen (mica, Arkansas stone or other stable standard) for data normalization.
17. Volumetric pipettes and flasks.

SPECIAL PRECAUTIONS: Asbestos, a human carcinogen, should be handled in a hood [4].
2-Propanol is flammable.

SAMPLING:

1. Place several grams of the dust to be analyzed in a plastic vial, seal the vial securely, and ship in a padded carton.

SAMPLE PREPARATION:

2. Place about 0.5 g of sample dust in a grinding vial and grind in a liquid nitrogen-cooled mill for 2 min to 10 min.
3. Wet sieve the ground dust using a 10 μm sieve and 2-propanol. Place the dust on the sieve and place the sieve directly in an ultrasonic bath or in a wide dish in the bath. Use enough 2-propanol to cover the dust (put water in the bath if a dish is used to contain the 2-propanol). Apply ultrasonic power to sieve the dust.
NOTE: It may take some time to obtain several mg of dust. Heating of the 2-propanol is likely and cooling periods may be required.
4. Recover the sieved sample dust from the 2-propanol by filtering the suspension through a non-fibrous filter (polycarbonate) or by driving off the 2-propanol on a hot plate. Dry the sieved sample in 110 $^{\circ}\text{C}$ oven for 4 h or more.
5. Weigh out about 5 mg of the sieved material onto a small square of tared weighing paper. Record the actual sample weight, W_s , to the nearest 0.01 mg. Transfer the dust to a 50 mL beaker, washing the weighing paper with several mL of 2-propanol. Add 10 mL to 15 mL 2-propanol to the beaker.
6. Cover the beaker with a watch glass. Agitate in an ultrasonic bath at least 3 min until all agglomerated particles are dispersed. Wash the underside of the watch glass with 2-propanol, collecting the washings in the beaker.

7. Place a silver filter in the filtration apparatus. Attach the funnel securely over the entire filter circumference. With no vacuum, pour 2 mL to 3 mL 2-propanol onto the filter. Pour the sample suspension from the beaker into the funnel and apply vacuum. During filtration, rinse the beaker several times and add rinsings to the funnel.

NOTE: Control the filtration rate to keep the liquid level in the funnel near the top during rinsing. Do not wash the walls or add 2-propanol to the funnel when the liquid level is lower than 4 cm above the filter. Leave the vacuum on after filtration for sufficient time to produce a dry filter.

8. Remove the filter with forceps and attach it to the sample holder for XRD analysis.

CALIBRATION AND QUALITY CONTROL:

9. Prepare and analyze working standard filters:

- a. Prepare two suspensions of chrysotile asbestos in 2-propanol by weighing 10 mg and 100 mg of the dry powder to the nearest 0.01 mg. Quantitatively transfer each to a 1 L glass-stoppered bottle using 1.00 L 2-propanol.

NOTE: Depending on the particle size of the standard, it may need to be ground and wet sieved (step 3). Dry the standards in a 110 °C oven for 4 h or more. Store in a desiccator.

- b. Suspend the powder in the 2-propanol with an ultrasonic probe or bath for 20 min. Immediately move the flask to a magnetic stirrer with thermally-insulated top and add a stirring bar to the suspension. Cool the solution to room temperature before withdrawing aliquots.
- c. Mount a filter on the filtration apparatus. Place several mL 2-propanol on the filter surface. Turn off the stirrer and shake vigorously by hand. Within a few seconds of setting the bottle down, remove the lid and withdraw an aliquot from the center of the 10 mg/L or 100 mg/L suspension. Do not adjust the volume in the pipet by expelling part of the suspension. If more than the desired aliquot is withdrawn, return all of the suspension to the bottle, rinse and dry the pipet, and take a new aliquot. Transfer the aliquot from the pipet to the filter. Keep the tip of the pipet near the surface but not submerged in the delivered suspension.
- d. Rinse the pipet with several mL 2-propanol, draining the rinse into the funnel. Repeat the rinse several more times. Prepare working standard filters, in triplicate, by this technique, at e.g., 0 µg, 20 µg, 30 µg, 50 µg, 100 µg, 200 µg, and 500 µg.
- e. Apply vacuum and rapidly filter the suspension. Leave vacuum on until filter is dry. Do not wash down the sides of the funnel after the deposit is in place since this will rearrange the material on the filter. Transfer the filter to the sample holder.
- f. Analyze by XRD (step 12). The XRD intensities (step 12.d) are designated I_x° and are then normalized (step 12.e) to obtain \hat{I}_x° . The intensities for standards greater than 200 µg should be corrected for matrix absorption (steps 12.f and 13).
- g. Prepare a calibration graph by plotting \hat{I}_x° as a function of the deposited asbestos mass, W_A , µg, of each standard.

NOTE: Poor repeatability (relative standard deviation greater than 10% above 40 µg chrysotile) indicates that new standards should be made. The data should lie along a straight line. It is preferable to use a weighted least squares with $1/\sigma^2$ weighing, where σ^2 is the variance of the data at a given loading.

- h. Determine the slope, m , of the calibration curve in counts per microgram. The intercept on the abscissa should be $0 \mu\text{g} \pm 5 \mu\text{g}$.

NOTE: A large intercept indicates an error in determining the background, i.e., an incorrect baseline has been calculated or interference by another phase.

10. Select six silver membrane filters as media blanks (for determination of sample self-absorption, step 13) randomly from the same box of filters to be used for depositing the samples. Mount each of the media blanks on the filtration apparatus and apply vacuum to draw 5 mL to 10 mL of 2-propanol through the filter. Remove, let dry, and mount on sample holders. Determine the net normalized count for the silver peak, \hat{I}_{Ag}° , for each media blank (step 12). Obtain an average value, \bar{B}_{Ag} , for the normalized silver peak intensities of the six media blanks.

MEASUREMENT:

11. Obtain a qualitative X-ray diffraction scan (e.g., 10 degrees to 80 degrees 2-theta) of the sample to determine the presence of chrysotile and interferences. The expected diffraction peaks are as follows:

| Mineral | Peak (2-Theta Degrees) | |
|------------|------------------------|-----------|
| | Primary | Secondary |
| Chrysotile | 12.08 | 24.38 |
| Silver | 38.12 | 44.28 |

12. Mount the filter (sample, standard, or blank) in the XRD instrument and:
- Determine the net intensity, I_r , of the reference specimen before each filter is scanned. Select a convenient normalization scale factor, N , which is approximately equivalent to the net count for the reference specimen peak, and use this value of N for all analyses.
 - Measure the diffraction peak area of a chrysotile peak that is free of interference. Scan times should be long, e.g., 15 min.
 - Measure the background on each side of the peak for one-half the time used for peak scanning. The sum of these two counts is the average background. Determine the position of the background for each sample.
 - Calculate the net intensity, I_x (the difference between the peak integrated count and the total background count).
 - Calculate and record the normalized intensity, \hat{I}_x , for the sample peak on each sample and standard:

$$\hat{I}_x = \frac{I_x}{I_r} N.$$

NOTE: Normalizing to the reference specimen intensity compensates for long-term drift in X-ray tube intensity. If intensity measurements are stable, the reference specimen may be run less frequently; net intensities should be normalized to the most recently measured reference intensity.

- Determine the net count, I_{Ag} , of an interference-free silver peak on the sample filter following the same procedure. Use a short scan time for the silver peak (for example, 5% of scan time for analyte peaks) throughout the method. Normalize I_{Ag} (step 12.e) to obtain \hat{I}_{Ag} .
- Scan each field blank over the same 2-theta range used for the analyte and silver peaks. These analyses serve only to verify that contamination of the filters has not occurred. The analyte peak should be absent. The normalized intensity of the silver peak should match that of the media blanks.

CALCULATIONS:

13. Calculate the percentage, C , of chrysotile in the bulk dust sample:

$$C = \frac{(\hat{I}_x \times f(T) - b) \times 100}{m \times W_s}, \%$$

where: \hat{I}_x = normalized asbestos peak intensity for sample peak,
 b = intercept of calibration graph (\hat{I}_x vs. W_A),
 m = slope of calibration graph (counts per μg),

$$f(T) = \frac{-R \ln(T)}{1 - T^R} = \text{absorption correction factor (see Tables 1a and 1b),}$$

$$R = \sin(\theta_{Ag}) / \sin(\theta_x),$$

$T = \hat{I}_{Ag} / \bar{B}_{Ag}$ = transmittance of sample,

\hat{I}_{Ag} = normalized silver peak intensity from sample,

\bar{B}_{Ag} = average normalized silver peak intensity from media blanks (average of six values), and

W_s = mass, μg , of deposited sample.

NOTE: For a more detailed discussion of the absorption correction procedure, see references 5, 6, 7, and 8.

EVALUATION OF METHOD:

This method is based on the work of B.A. Lange in developing P&CAM 309 [1,2]. Samples in the range of 1% to 100% chrysotile in talc were studied to establish the feasibility of an XRD method for airborne asbestos. Analytical precision was as follows:

| % Chrysotile in Talc | \bar{S}_r (%) |
|----------------------|-----------------|
| 100 | 6.9 |
| 10 | 4.7 |
| 7 | 9.8 |
| 5 | 8.2 |
| 3 | 10.1 |
| 1 | 12.5 |

This work also showed that bias of results after absorption corrections are made is negligible.

REFERENCES:

- [1] Lange BA, Haartz JC [1979]. Determination of microgram quantities of asbestos by x-ray diffraction: chrysotile in thin dust layers of matrix material. *Anal Chem* 51(4):520–525.
- [2] NIOSH [1979]. Chrysotile asbestos (bulk): P&CAM 309. In: Taylor DG, ed. NIOSH manual of analytical methods. 2nd ed. Vol. 5. Cincinnati, OH: U.S. Department of Health, Education, and Welfare, Center for Disease Control, National Institute for Occupational Safety and Health, DHEW (NIOSH) Publication No. 79-141, available as accession No. PB83-105445 from NTIS [www.ntis.gov].
- [3] Perkins RL, Harvey BW [1993]. Test method: method for the determination of asbestos in bulk building material. Washington, DC: US Environmental Protection Agency, Office of Research and Development, EPA/600/R-93-116 [www.nist.gov/nvlap/upload/EPA-600-R-93-116.pdf].
- [4] NIOSH [1976]. Revised recommended asbestos standard. Cincinnati, OH: U.S. Department of Health, Education, and Welfare, Center for Disease Control, National Institute for Occupational Safety and Health, DHEW (NIOSH) Publication No. 77-169 [www.cdc.gov/niosh/docs/77-169/].
- [5] Leroux J, Powers CA [1970]. Direct x-ray diffraction quantitative analysis of quartz in industrial dust films deposited on silver membrane filters. *Occup Health Rev* 21(1):26–34.
- [6] Williams PP [1959]. Direct quantitative diffractometric analysis. *Anal Chem* 31(11):1842–1844.
- [7] Abell MT, Dollberg DD, Lange BA, Hornung RW, Haartz JC [1981]. Absorption corrections in x-ray diffraction dust analyses: procedures employing silver filters. In: Russell PA, ed. *Electron microscopy and x-ray applications to environmental and occupational health analysis*. Vol. 2. Ann Arbor, MI: Ann Arbor Science Publishers, Inc., pp. 115–118.
- [8] Dollberg DD, Abell MT, Lange BA [1980]. Occupational health analytical chemistry: quantitation using x-ray powder diffraction. In: Dollberg DD, Verstuyft AW, eds. *Analytical techniques in occupational health chemistry*. Washington, DC: American Chemical Society, ACS Symposium Series No. 120, pp. 43–65.

METHOD REVISED BY:

M. T. Abell, NIOSH/DPSE.

DISCLAIMER: Mention of any company or product does not constitute endorsement by NIOSH. In addition, citations to websites external to NIOSH do not constitute NIOSH endorsement of the sponsoring organizations or their programs or products. Furthermore, NIOSH is not responsible for the content of these websites. All web addresses referenced in this document were accessible as of the publication date.

Table 1a. Absorption correction factor as a function of transmittance (1.00 to 0.70) for chrysotile primary and secondary peak combinations with silver primary peak

| Transmittance | Absorption Correction Factor | |
|---------------|------------------------------|----------------|
| | Primary Peak | Secondary Peak |
| 1.00 | 1.0000 | 1.0000 |
| 0.99 | 1.0157 | 1.0078 |
| 0.98 | 1.0317 | 1.0157 |
| 0.97 | 1.0480 | 1.0237 |
| 0.96 | 1.0647 | 1.0319 |
| 0.95 | 1.0817 | 1.0402 |
| 0.94 | 1.0991 | 1.0486 |
| 0.93 | 1.1168 | 1.0572 |
| 0.92 | 1.1350 | 1.0659 |
| 0.91 | 1.1535 | 1.0747 |
| 0.90 | 1.1724 | 1.0837 |
| 0.89 | 1.1917 | 1.0928 |
| 0.88 | 1.2114 | 1.1021 |
| 0.87 | 1.2316 | 1.1115 |
| 0.86 | 1.2522 | 1.1212 |
| 0.85 | 1.2733 | 1.1309 |
| 0.84 | 1.2948 | 1.1409 |
| 0.83 | 1.3168 | 1.1510 |
| 0.82 | 1.3394 | 1.1613 |
| 0.81 | 1.3624 | 1.1718 |
| 0.80 | 1.3859 | 1.1825 |
| 0.79 | 1.4100 | 1.1933 |
| 0.78 | 1.4346 | 1.2044 |
| 0.77 | 1.4598 | 1.2157 |
| 0.76 | 1.4856 | 1.2272 |
| 0.75 | 1.5120 | 1.2389 |
| 0.74 | 1.5390 | 1.2508 |
| 0.73 | 1.5666 | 1.2630 |
| 0.72 | 1.5949 | 1.2754 |
| 0.71 | 1.6239 | 1.2881 |
| 0.70 | 1.6536 | 1.3010 |

Table 1b. Absorption correction factor as a function of transmittance (0.69 to 0.39) for chrysotile primary and secondary peak combinations with silver primary peak

| Transmittance | Absorption Correction Factor | |
|---------------|------------------------------|----------------|
| | Primary Peak | Secondary Peak |
| 0.69 | 1.6839 | 1.3142 |
| 0.68 | 1.7151 | 1.3277 |
| 0.67 | 1.7470 | 1.3414 |
| 0.66 | 1.7797 | 1.3555 |
| 0.65 | 1.8132 | 1.3698 |
| 0.64 | 1.8475 | 1.3845 |
| 0.63 | 1.8827 | 1.3995 |
| 0.62 | 1.9188 | 1.4148 |
| 0.61 | 1.9558 | 1.4305 |
| 0.60 | 1.9938 | 1.4465 |
| 0.59 | 2.0328 | 1.4629 |
| 0.58 | 2.0728 | 1.4797 |
| 0.57 | 2.1139 | 1.4969 |
| 0.56 | 2.1560 | 1.5145 |
| 0.55 | 2.1993 | 1.5325 |
| 0.54 | 2.2438 | 1.5510 |
| 0.53 | 2.2895 | 1.5700 |
| 0.52 | 2.3365 | 1.5895 |
| 0.51 | 2.3848 | 1.6095 |
| 0.50 | 2.4344 | 1.6300 |
| 0.49 | 2.4855 | 1.6510 |
| 0.48 | 2.5380 | 1.6727 |
| 0.47 | 2.5921 | 1.6950 |
| 0.46 | 2.6478 | 1.7179 |
| 0.45 | 2.7051 | 1.7414 |
| 0.44 | 2.7642 | 1.7657 |
| 0.43 | 2.8251 | 1.7907 |
| 0.42 | 2.8879 | 1.8165 |
| 0.41 | 2.9526 | 1.8431 |
| 0.40 | 3.0195 | 1.8705 |
| 0.39 | 3.0885 | 1.8989 |

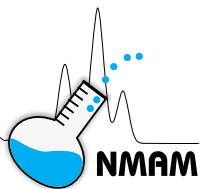

METHAMPHETAMINE and Illicit Drugs, Precursors and Adulterants on Wipes by Liquid-Liquid Extraction

9106

FORMULA: Table 1

MW: Table 1

CAS: Table 1

RTECS: Table 1

METHOD: 9106, Issue 1

EVALUATION: Partial

Issue 1: 17 October 2011

OSHA: none for surfaces
 NIOSH: none for surfaces
 Other OELs and guidelines: [1, 2, 3]

PROPERTIES: Table 2

SYNONYMS: Table 3

| SAMPLING | | MEASUREMENT | |
|--|---|--|--|
| SAMPLER: | Wipe | TECHNIQUE: | GAS CHROMATOGRAPHY/MASS SPECTROMETRY |
| SAMPLE AREA: | 100 cm ² or 1000 cm ² | ANALYTES: | Table 1 |
| SHIPMENT: | Preferably ship refrigerated, <6 °C | DESORPTION: | 0.1 M sulfuric acid |
| SAMPLE STABILITY: | 30 days at <6 °C (See Table 4) | CLEANUP/EXTRACTION: | Hexane cleanup followed by methylene chloride extraction |
| FIELD BLANKS: | 2 to 10 blanks per sample set | DERIVATIZATION: | Chlorodifluoroacetic anhydride |
| MEASUREMENT ACCURACY | | INJECTION: | 2 µL, splitless |
| LEVEL STUDIED: | 3 µg/sample on smooth surfaces | TEMPERATURE | |
| BIAS: | Table 10a and 10b | - Injection: | 265 °C |
| OVERALL PRECISION ($\hat{S}_{r,T}$): | Table 7a and 7b [4] | - Detector: | 285 °C |
| ACCURACY: | Table 7a and 7b [4] | - Column: | 90 °C (2 min), 310 °C (10 °C/min), hold for 11 min |
| | | MASS SPECTROMETER: | Scan mode (29 – 470 AMU), 2 scan per sec, Selected ion monitoring (SIM) mode Table 5 |
| | | CARRIER GAS: | Helium, 1.5 mL/min |
| | | COLUMN: | Capillary, fused silica, 30 m × 0.32 mm ID; 0.5 µm film phenyl arylene polymer |
| | | CALIBRATION: | Standards from spiked wipes with internal standard, See Table 6 |
| | | RANGE: | Table 7a and 7b [4] |
| | | ESTIMATED LOD: | Table 4 |
| | | PRECISION (\bar{S}_r): | Table 7a and 7b [4] |

APPLICABILITY: For methamphetamine, the range is 0.05 to 60 µg/sample (sample = 100 cm² or 1000 cm²). This method was developed for the analysis of selected drugs and precursors on surfaces in clandestine drug labs. [4, 5] Sampling methodology was tested using wipes on smooth, non-porous surfaces. The APPENDIX contains sampling information for other types of surfaces.

INTERFERENCES: No chromatographic interferences detected. Water, surfactants and polyols inhibit derivatization.

OTHER WIPE METHODS: NIOSH 9109 uses solid-phase extraction and gas chromatography/mass spectrometry (GC/MS) to measure multiple drugs [6]. NIOSH 9111 uses liquid chromatography/mass spectrometry (LC/MS) to measure methamphetamine [7].

REAGENTS:

NOTE: See APPENDIX A for special instructions on reagents.

1. Analytes listed in Table 1.*
2. Internal standards from those listed in Table 8.
3. Solvents, residue free analytical grades:
 - a. Hexane *
 - b. Isopropanol (IPA)*
 - c. Methanol *
 - d. Methylene chloride (CH₂Cl₂)*
 - e. Toluene *
 - f. Acetone*
4. Concentrated sulfuric and hydrochloric acids (AR or trace metals analysis grades).*
5. Sodium hydroxide, A.C.S. grade.*
6. Anhydrous granular sodium sulfate, AR grade.
7. Anhydrous granular potassium carbonate, AR grade.
8. Bromothymol Blue, ≥95%, A.C.S., phenolphthalein, A.C.S.; crystal violet (Gentian Violet), ≥95%, A.C.S.
9. Purified gases: helium for carrier gas, nitrogen for drying.
10. Chlorodifluoroacetic anhydride, 98%* derivatizing agent. Moisture sensitive!
11. 4,4'-Dibromooctafluorobiphenyl, 99%, instrument internal standard (IIS).
12. Deionized water (ASTM type II).

SOLUTIONS:

NOTE: See APPENDIX A for special instructions on solutions.

1. Prepare solutions of analytes of interest. Calculate concentrations as the free base. Keep refrigerated (<6 °C). Protect solutions from light.
 - a. Stock solutions are prepared at about 1-2 mg/mL in methanol.
 - b. Analyte spiking solutions are prepared by diluting the stock solutions to about 200 µg/mL each in methanol.
2. Prepare internal standard spiking solution in methanol at about 200 µg/mL. (Note: Add about 2 milligrams of crystal violet per 20 mL of internal standard spiking solution to help indicate which samples have been spiked.)
3. Desorption solution: 0.1 M H₂SO₄ (sulfuric acid.) Add 22 mL conc. sulfuric acid to 4 L deionized water.
4. Bromothymol blue and phenolphthalein pH indicator solution: 1 mg/mL each in 4:1 isopropanol: deionized water.
5. Sodium hydroxide*, 10 M: Dissolve 40 grams sodium hydroxide in enough deionized water to make 100 mL. Do not store in glass-stoppered bottle.
6. Hydrochloric acid, 0.3 M, in methanol: Dilute 2.5 mL conc. hydrochloric acid in about 80 mL methanol; dilute to 100 mL with methanol.
7. Crystal violet indicator: 2-3 mg/mL in isopropanol.
8. Reconstitution solvent: 10% acetone in toluene with 4 µg/mL of 4,4'-dibromooctafluorobiphenyl (optional).*

* See SPECIAL PRECAUTIONS

EQUIPMENT:

NOTE: See APPENDIX B for special instructions on equipment.

1. Wipe, (7.6 cm × 7.6 cm) 12-ply or equivalent.
2. Sample storage and shipping container: 50-mL polypropylene centrifuge tubes with PTFE-lined caps.
3. Extraction tubes and vials:
 - a. Glass test tubes, 25-mL (20 × 120 mm), with PTFE-lined caps;
 - b. Glass test tubes, 14-mL (16 × 100 mm), with PTFE-lined caps, (ASTM Specification E982 [5], or equivalent, suitable for repeated autoclaving);
 - c. Amber GC autosampler vials (2-mL) and caps.
4. Gas chromatograph/mass spectrometer detector, with column and integrator, see p. 9106-1.
5. Liquid Transfer:
 - a. Syringes: 10-, 25-, 100-, and 500-µL sizes.
 - b. Mechanical pipette with disposable tips or repeating dispenser: 0.5-, 2.5-, and 10-mL sizes.
 - c. Repeating dispenser: 1- to 5-mL.
 - d. Three repeating dispensers: 10 to 20-mL each.
6. Volumetric flasks: 10-, 100-, and 250-mL.
7. Forceps.
8. Gloves, latex or nitrile. Avoid vinyl gloves (see 9106-3, Sampling step 1, NOTE 2).
9. Scoop for solid reagents.
10. Empty drying columns: 1 cm i.d. × 12-15 cm length polypropylene plastic columns having a fritted polyethylene disc or equivalent (e.g. 10-mL pipette tip with small wad of silanized glass wool packed into the tip).
11. Nitrogen blow-down apparatus with water bath capable of maintaining 35 °C.
12. Vortex mixer.
13. Rotating mixer capable of 10-30 rpm.
14. Aspirator flask: 1-L, with aspirator tubing and a 12.5 cm long 16 gauge needle.
15. Centrifuge: capable of up to 4000 x g and of holding 25-mL glass test tubes.
16. Oven capable of 70 to 90 °C ± 2 °C.
17. Test tube racks, heat resistant to 90 °C.
18. Pasteur pipettes.
19. pH paper.
20. Template: 10 cm × 10 cm or 31.7 cm × 31.7 cm opening, made of relatively rigid disposable cardstock or sheet of PTFE.
21. Ice or other cold media for shipping.

SPECIAL PRECAUTIONS: The solvents are flammable and have adverse health effects. Phenethylamines target the nervous system at very low concentrations and are easily absorbed through the skin. Avoid breathing vapors. Avoid skin contact. Work should be performed in a hood with adequate ventilation. Analysts must wear proper eye and hand protection (e.g. latex gloves) to prevent absorption of even small amounts through the skin. Dissolving sodium hydroxide and concentrated hydrochloric or sulfuric acid in water is highly exothermic. Goggles must be worn. The derivatization reagents react violently with water.

Caution must also be exercised in the collecting, handling, and analysis of samples. Clandestine drug labs may produce unknown and seriously toxic by-products. For example, in the manufacture of designer drugs (e.g., MPPP, a homolog of Alphaprodine), at least one very neurotoxic by-product, 1-methyl-4-phenyl-1,2,5,6-tetrahydropyridine (MPTP), has been identified that specifically and irreversibly causes Parkinson's disease [8,9].

SAMPLING:

See APPENDIX C for special instructions on sampling.

1. Using a new pair of gloves, remove a gauze wipe from its protective package. Moisten the wipe with approximately 3 to 4 mL of methanol (or isopropanol).

NOTE 1: Apply no more solvent than that needed to moisten approximately the central 80% of the area of the gauze wipe. Excess solvent may cause sample loss due to dripping from the wipe.

NOTE 2: Do not use vinyl gloves due to the potential for leaching of phthalate plasticizers and contamination of the samples.

2. Place the template over the area to be sampled (may tape in place along outside edge of template). Wipe the surface to be sampled with firm pressure, using vertical S-strokes. Fold the exposed side of the pad in and wipe the area with horizontal S-strokes. Fold the pad once more and wipe the area again with vertical S strokes.
3. Fold the pad, exposed side in, and place in shipping container and seal with cap.

NOTE: Keep samples refrigerated (<6 °C). While methamphetamine and several related amines are stable on the recommended wipe media for at least 7 days at room temperature, refrigeration is recommended as soon as possible (see Table 4).

4. Either clean the template before use for the next sample or use a new disposable template.
5. Label each sample clearly with a unique sample identifier.
6. Prepare a minimum of two field blanks with one field blank for every ten samples.

NOTE: In addition, include at least 3 media blanks for the analytical laboratory to use for their purposes. The wipes used for the media blanks should be from the same lot as the field samples.

SAMPLE PREPARATION:

See APPENDIX D for special instructions on sample preparation.

7. Desorption from media:

- a. Remove cap from shipping container.

NOTE: Sample wipe should fit loosely in the container. If not, transfer sample to a larger container.

- b. Spike 60 µL of internal standard spiking solution onto each wipe sample.
- c. Add 30 mL desorption solution (0.1 M sulfuric acid).

NOTE: If the samples were transferred to a larger container, rinse the original shipping container with the desorption solution, shake, and decant the rinsate into the larger container.

- d. Cap securely and mix contents by inverting the tubes end over end on a rotary mixer or equivalent at 10-30 rpm for at least one hour.

- e. Check the pH which should be about ≤ 4 . Adjust the pH with diluted (2.5 to 3 M) sulfuric acid drop-wise, mixing the contents by shaking or inversion a few times after each addition of acid before checking the pH.
 - f. After mixing, transfer 10 mL of supernatant to a 25-mL glass centrifuge tube.
NOTE: If cleanup is to be performed on a subsequent day, store samples in a refrigerator.
Analytes are stable in the desorption solution for at least one week refrigerated.
8. Cleanup: Potential contamination from oils, triglycerides, plasticizers and other hydrocarbons are reduced through a hexane back-extraction step.
- a. To each 10-mL aliquot of acid desorbate, add 10 mL of hexane, cap and mix on a rotary mixer for one hour. Allow to stand for 15-30 minutes for the phases to separate. If an emulsion forms, centrifuge the tubes at 1500-2000 rpm for a few minutes. If the emulsion persists, add about 0.5 mL of acetonitrile to the surface of the emulsion and gently mix the layers at the interface of the emulsion. Centrifuge again if necessary.
 - b. Aspirate the (upper) organic layer to waste. Exercise care to not remove any of the aqueous layer.
9. Extraction of analytes into methylene chloride:
- a. Add 1-2 drops (20-50 μ L) of the mixed pH indicator (phenolphthalein + bromothymol blue) solution to each sample. The color of the samples should be yellow, which indicates that the samples are sufficiently acidic for desorption of the analytes from the wipe samples.
 - b. Add 0.5 mL of 10 M sodium hydroxide to each sample. The color of the samples should turn brilliant purple or magenta, confirming that the pH is greater than 9-9.5 (necessary for the extraction of the amines into methylene chloride). If the color remains yellow, or only turns green or light blue, check the pH with pH paper to confirm that it is greater than 9.5. If it is not, add another 0.5 mL of 10 M sodium hydroxide, mix, and check the pH again.
NOTE: The color of the solution will gradually fade from purple to deep blue within about 20-30 minutes. This is due to the known tendency of phenolphthalein to fade at high pH.
 - c. Add 10 mL of methylene chloride to each sample. Cap and mix on a rotary mixer for one hour. Allow to stand for 15 to 30 minutes. If an emulsion forms, centrifuge as described above (step 8a).
 - d. Aspirate the aqueous (upper) layer to waste as described above, being careful to not remove any of the lower methylene chloride layer.
10. Removal of water from the methylene chloride extract:
- a. Prepare potassium carbonate-sodium sulfate drying columns.
Note: See APPENDIX E for preparation of drying columns.
 - b. Rinse the packed columns with about 6 mL of methylene chloride. Dry columns afterwards by forcing dry nitrogen or clean air through the top for 10-20 seconds.
 - c. Arrange 14-mL collection tubes (16 \times 100 mm test tube) in test tube racks. Add 6 μ L of crystal violet solution and 100 μ L of 0.3 M hydrochloric acid in methanol to each collection tube.
NOTE: Crystal violet is not critical but helps later on as a visualizing aid for monitoring the progress of drying. Hydrochloric acid is critical to prevent loss of the amphetamines during evaporative concentration.
 - d. Position the drying columns over the collection tubes.
 - e. Transfer (decant) the methylene chloride layer into the drying column reservoir. After the last of the sample passes into the bed of the column, rinse the drying column twice with 1 mL of methylene chloride each time and combine with sample eluate.
11. Derivatization:
See APPENDIX F for special instructions on derivitization.
- a. Evaporate the methylene chloride eluates in a nitrogen blow-down apparatus with the water bath set at 35 $^{\circ}$ C. Rinse the tips of the evaporation needles thoroughly with methanol or acetone between samples to prevent cross-contamination. When the samples are dry, remove and cap the tubes immediately.

- NOTE: The dark color of the crystal violet helps make the residue more visible when it is dried. If at least 0.1 mL of isopropanol was present in the eluates, the crystal violet will also go through a series of color changes that helps in monitoring the drying process.
- b. To each dried sample, add 100 μ L of chlorodifluoroacetic anhydride and recap tubes. Mix the contents by vortexing briefly.
- NOTE 1: It is recommended that the tubes be kept capped and to only uncap about 5 at a time for the addition of the derivatizing reagent. Do not leave the acid anhydride bottle open between taking aliquots since the reagent is moisture sensitive.
- NOTE 2: If incomplete derivatization is routinely experienced, increase volume of reagent to 150 or 200 μ L. The color of the crystal violet will turn yellow or yellow-green with the addition of chlorodifluoroacetic anhydride.
- c. Heat in an oven at 70-75 $^{\circ}$ C for 20-30 minutes.
- d. After heating, allow the tubes to cool to room temperature. Remove caps and evaporate the contents to dryness under a stream of nitrogen at room temperature. As the solution concentrates it turns from a yellow or yellowish-green solution to a bluish-green just before going to dryness. At the point of dryness the color of the residue normally turns rapidly to blue or violet, depending upon the amount of coextractants (the more co-extractants, the more blue the color and the less likely a violet color will develop). Remove the tubes just as soon as the blue or violet color becomes apparent. Losses have been experienced if blowing is continued for more than 2 minutes beyond the blue or violet color stage.
- NOTE: If an oil-like residue or film persists, then the sample may have too many contaminants that were not removed at the cleanup step or were introduced subsequent to cleanup. In such a case, return to step 7f and perform the clean-up (step 8) on another 10-mL aliquot of the sample desorbate using methylene chloride as the cleanup solvent instead of hexane. Discard the (lower) organic layer to waste before proceeding to steps 9 through 11.
- e. Reconstitute the dried residue with 1 mL of the reconstitution solvent. The reconstituted solution normally will become deep blue in color. Mix by vortexing briefly a couple of times. Transfer the solutions to 2-mL amber-colored GC vials containing 200 to 250 mg anhydrous sodium sulfate. Cap vials, label, and analyze by GC/MS (See MEASUREMENT, steps 15-17).
- NOTE: Derivatives of phenylpropanolamine (norephedrine) break down significantly over several days at room temperature. GC vials containing derivatives should be kept refrigerated until analysis.

CALIBRATION AND QUALITY CONTROL:

12. Determine retention times for the derivatives of the analytes of interest using the column and chromatographic conditions specified on page 9106-1. Table 9 gives typical retention times for various drugs, precursors, and adulterants.
13. Calibrate daily with at least six calibration standards plus a blank (CS0) selected from Table 6 to cover the analytical range.
- a. Prepare the analyte spiking solution as follows: Add known amounts of individual drug stock solutions to a volumetric flask and dilute to volume with methanol. A recommended final concentration for this solution is approximately 200 μ g each per mL.
- b. Prepare calibration standards and media blanks in clean shipping containers (e.g. 50-mL polypropylene centrifuge tubes or equivalent).
- NOTE: Liquid standards (standards without added blank wipe media) may be prepared in lieu of media standards if cotton gauze was used for the samples.
- c. Add 3 mL methanol (or isopropanol, if isopropanol was used with the samples in the field) to each calibration standard and media blank.

- d. Spike a known volume of analyte spiking solution into each calibration standard by spiking directly onto the media or into solution. Use the spiking volumes suggested in Table 6 to cover the desired range.
 - e. Process each of these through steps 7 through 11 (same as the field samples.)
 - f. Analyze these along with the field samples. (See MEASUREMENT, steps 15-17.)
14. Prepare matrix-spiked (QC) and matrix-spiked duplicate (QD) quality control samples [12].
- a. Cotton gauze from the same lot used for taking samples in the field should be provided to the analytical laboratory to prepare these matrix-spiked quality control samples.
 - b. The quality control samples (QC and QD) must be prepared independently at concentrations within the analytical range. (See Table 6 for applicable concentration ranges.)
 - c. One quality control media blank (QB) must be included with each QC and QD pair.
 - i. Transfer clean gauze wipes to new shipping containers.
 - ii. Add 3 mL of isopropanol (or methanol, if methanol was used in wiping) to each gauze wipe.
 - iii. Spike QC and QD with a known amount of analyte as suggested in Table 6.
 - d. Process each of these through steps 7 through 11 (same as the field samples).
 - e. Analyze these along with the field samples. (See MEASUREMENT, steps 15-17.)

MEASUREMENT:

See APPENDIX G for special instructions on measurement.

15. Analyze the calibration standards, quality control samples, blanks, and samples by GC/MS.
- a. Set gas chromatograph according to manufacturer's recommendations and to conditions listed on page 9106-1.
 - b. Set mass spectrometer conditions to manufacturer's specifications and those given on page 9106-1 for the scan mode or those in Table 5 for the SIM mode.
 - c. Inject sample aliquot with autosampler or manually.

NOTE: After the derivatives are prepared and just before analyzing any samples or standards, inject the highest concentrated standard several times in order to prime or deactivate the GC column and injection port. This will help minimize any drift in the instrument's response to target analytes relative to their internal standards.
 - d. After analysis, the vials should be recapped promptly and refrigerated if further analysis is anticipated.
16. Using extracted ion current profiles for the primary (quantification) ions specific to each analyte, measure GC peak areas of analyte(s) and internal standard(s) and compute relative peak areas by dividing the peak area of the analyte by the area of the appropriate internal standard. Recommended primary (quantification) ions and internal standards are given in Tables 5, 7, and 8. Prepare calibration graph (relative peak area vs. μg analyte per sample).
17. Samples from initial investigations of clandestine laboratories are likely to include highly contaminated samples. If sample results exceed the upper range of the calibration curve, the sample in the GC vial may be diluted and reanalyzed or a smaller aliquot of the initial acid desorbate diluted, re-extracted, derivatized, and analyzed. Refer to APPENDIX H for instructions and limitations on making dilutions.

CALCULATIONS:

18. Determine the mass (in $\mu\text{g}/\text{sample}$) of respective analyte found in the wipe samples, and in the media blank from the calibration graph.
19. Calculate final concentration, C , of analyte in $\mu\text{g}/\text{sample}$:

$$C = c \frac{V_1 V_3}{V_2 V_4} - b \frac{V_5}{V_2}$$

Where: c = concentration in sample (in $\mu\text{g}/\text{sample}$ determined from the calibration curve).

$\frac{V_1}{V_2}$ = volume correction factor (needed only when the volume of internal standard spiking solution used for spiking the samples – such as for composite samples requiring larger desorption solution volumes – is different from that used for spiking the calibration standards). (See Table 6, footnote 4.)

V_1 = volume in μL of internal standard spiking solution used to spike samples.

V_2 = volume in μL of internal standard spiking solution used to spike the standards.

$\frac{V_3}{V_4}$ = dilution factor, if applicable

V_3 = 10 mL (volume of desorbate taken for cleanup in step 8).

V_4 = volume in mL of desorbate actually taken for cleanup and diluted to 10 mL with blank desorbing solution containing internal standard.

b = concentration in media blank (in $\mu\text{g}/\text{sample}$ determined from the calibration curve).

$\frac{V_5}{V_2}$ = volume correction factor for the media blank (needed only if the volume of internal standard spiking solution used for spiking the media blank is different from that used for spiking the calibration standards.)

V_5 = volume in μL of internal standard spiking solution used to spike media blank.

20. Report concentration, C' , in μg per total area wiped (in cm^2) as follows:

$$C' = \frac{C}{A}$$

Where: C = $\mu\text{g}/\text{sample}$ (step 19).

A = Total area wiped in cm^2 per sample.

NOTE: For example, if the sample was a composite sample and the area was 400 cm^2 , report results as $\mu\text{g}/400 \text{ cm}^2$ and not averaged to $\mu\text{g}/100 \text{ cm}^2$. In general, if the area wiped was greater than or less than 100 cm^2 , do not convert value to $\mu\text{g}/100 \text{ cm}^2$. To avoid confusion, report separately both $\mu\text{g}/\text{sample}$ (C) and the total area wiped in cm^2 per sample (A) for both discrete and composite samples.

EVALUATION OF METHOD:

This method was evaluated for those analytes listed in Tables 7a and 7b over a range of approximately $0.1 \mu\text{g}/\text{sample}$ to $30 \mu\text{g}/\text{sample}$. These concentration levels represent approximately the 1 through 300 times the limit of quantitation (LOQ) level for most of the analytes [9]. Results are reported in the Backup Data Report for NIOSH 9106 [4].

The limits of detection (LOD and LOQ) were determined by preparing a series of liquid standards in desorption solution, processing them through the liquid-liquid extraction procedure of NIOSH 9106, and analyzing in both the scan and SIM modes. The LODs were estimated using the procedure of Burkart [12]. An LOD of $0.05 \mu\text{g}/\text{sample}$ for methamphetamine on wipes was achieved in either scan or SIM mode. The LOD was set at $0.05 \mu\text{g}/\text{sample}$ because that was the level of the lowest calibration standard for the LOD study. Lower LODs (e.g. $0.02 \mu\text{g}/\text{sample}$) have been achieved in practice by including calibration standards at lower concentration levels. The cleanliness and performance of the mass spectrometer must be maintained such that at $0.1 \mu\text{g}/\text{sample}$, a signal of at least 5 to 10 times the baseline noise is achievable. This is more easily accomplished in the SIM mode with the mass spectrometer.

Six different wipe media were evaluated. These were 3"×3" 12-ply cotton gauze, 4"×4" AlphaWipes® (TX® 1004), 4"×4" 4-ply NU GAUZE®, 4"×4" 4-ply MIRASORB®, 4"×4" 6-ply SOF-WICK®, and 4"×4" 4-ply TOPPER® sponges. Results are given in the Backup Data Report [1]. No synthetic media performed

better than cotton gauze. Some media (TOPPER® and SOF-WICK®) did not perform well, possibly due to co-extracted nonionic (polyethoxyethylene type) surfactants that are not removed using hexane and incompletely removed using methylene chloride in the cleanup step.

Precision and accuracy were determined by analyzing 6 replicates at each of 6 concentration levels (nominally 0.1, 0.3, 1, 3, 10, and 30 µg/sample). Results are presented in Tables 7a and 7b for cotton gauze. The best precision and accuracies were dependent upon the use of carefully chosen internal standards, especially where there is steric hindrance of the amine (e.g. having *N*-ethyl and *N*-propyl groups).

Long term sample storage stability was determined for periods up to 30 days under refrigeration (4 °C ± 2 °C) and for up to 7 days at room temperature (22-24 °C). Results are given in Table 4. The precision and accuracy and long term storage stability evaluations were conducted using isopropanol as the wetting solvent. A second precision and accuracy study using methanol confirmed that methanol is an acceptable substitute for isopropanol.

Recovery of amphetamines from six different types of surfaces using cotton gauze was evaluated (see Tables 10a and 10b). The practice of serial wiping (wiping the same surface area a second time with a second gauze wipe and combining both wipes as a single sample) was evaluated. Four solvents for wetting the gauze were tested (distilled water, 5% distilled white vinegar, isopropanol, and methanol). Six replicate samples were made on a latex painted wall. Recoveries and precisions are given in Table 10a. The recoveries with 5% distilled white vinegar were better than for distilled water, but not as good as for isopropanol. Methanol is superior to isopropanol. Recoveries with isopropanol are greatly improved with a repeat (serial) wipe (11% improvement compared to only about 6% improvement with methanol). The study and results are reported in the Backup Data Report for NIOSH 9109 [13]. Additional research on surface sample recovery and solvent effectiveness has been reported by Serrano et al. [15] and VanDyke et al. [16].

REFERENCES:

- [1] ACGIH [2013]. TLVs and BEIs based on the documentation of the Threshold Limit Values for chemical substances and physical agents and Biological Exposure Indices. Cincinnati, Ohio: American Conference of Governmental Industrial Hygienists. [www.acgih.org]. Data accessed April 2014.
- [2] Institut für Arbeitsschutz der Deutschen Gesetzlichen Unfallversicherung [2013]. GESTIS database on hazardous substances (German Social Accident Insurance). Sankt Augustin, FRG: [http://www.dguv.de/ifa/GESTIS]. Data accessed April 2014.
- [3] EPA [2013]. Voluntary guidelines for methamphetamine laboratory cleanup. [https://www.epa.gov/sites/production/files/documents/meth_lab_guidelines.pdf]. Date accessed March 2016.
- [4] Reynolds JM, Siso MC, Perkins JB [2004]. Backup data report for NIOSH 9106, Methamphetamine and illicit drugs, precursors, and adulterants on wipes by liquid-liquid extraction, Abridged, prepared under NIOSH Contract 200-2001-0800, Unpublished.
- [5] Martyny JW, Arbuckle SL, McCammon CS Jr., Esswein EJ, Erb N [2003]. Chemical exposures associated with clandestine methamphetamine laboratories. [https://www.env.nm.gov/cdli/docs/Chemical_Exposures.pdf].
- [6] NIOSH [2011]. Methamphetamine and illicit drugs, precursors, and adulterants on wipes by solid phase extraction: Method 9109. In: Ashley KA, O'Connor PF, eds. NIOSH manual of analytical methods. 5th ed. Cincinnati, OH: U.S. Department of Health and Human Services, Centers for Disease Control and Prevention, National Institute for Occupational Safety and Health, [www.cdc.gov/niosh/nmam/].
- [7] NIOSH [2011]. Methamphetamine on Wipes by Liquid Chromatography/Mass Spectrometry: Method 9111. In: Ashley KA, O'Connor PF, eds. NIOSH manual of analytical methods. 5th ed. Cincinnati, OH: U.S. Department of Health and Human Services, Centers for Disease Control and Prevention, National Institute for Occupational Safety and Health, [www.cdc.gov/niosh/nmam/].

- [8] ASTM International [2015]. ASTM-E982-94(2015), Standard specification for laboratory glass test tubes. West Conshohocken, PA: ASTM International.
- [9] Baum RM [1985]. New variety of street drugs poses growing problem. *Chemical and Engineering News*, 63(63):7-16.
- [10] Buchanan JF, Brown CR [1988]. Designer drugs, a problem in clinical toxicology. *Medical Toxicology* 3:1-17.
- [11] NIOSH [1994]. Chapter C: Quality Assurance. In: Eller PM, Cassinelli ME, eds. *NIOSH Manual of Analytical Methods*, 4th ed. Cincinnati, OH: Department of Health and Human Services, Centers for Disease Control and Prevention, National Institute for Occupational Safety and Health, DHHS (NIOSH) Publication No. 94-113. [www.cdc.gov/niosh/nmam/].
- [12] Burkart JA [1986]. General procedures for limit of detection calculations in the industrial hygiene chemistry laboratory. *Appl Ind Hygiene* 1(3):153-155.
- [13] Reynolds JM, Siso MC, Perkins JB [2004]. Backup data report for NIOSH 9109, Methamphetamine and illicit drugs, precursors, and adulterants on wipes by solid phase extraction. Unpublished. Prepared under NIOSH Contract 200-2001-0800.
- [14] Budavari S, ed. [1989]. *Merck Index*, 11th ed. Rahway, NJ: Merck and Co., Inc.
- [15] Serrano KA, Martyny JW, Kofford S, Contreras JR, Van Dyke MV [2012]. Decontamination of clothing and building materials associated with the clandestine production of methamphetamine. *J Occup Environ Hyg* 9(3):185-197.
- [16] Van Dyke MV, Serrano KA, Kofford S, Contreras J, Martyny JW [2011]. Variability and specificity associated with environmental methamphetamine sampling and analysis. *J Occup Environ Hyg* 8(11):636-41.
- [17] Sweet DV, ed. [1997]. Registry of toxic effects of chemical substances. DHHS (NIOSH) Publ. No. 97-119. <https://www.cdc.gov/niosh/>.
- [18] Sigma-Aldrich MSDS sheets, <http://www.sigma-aldrich.com> [May 10, 2004].
- [19] Cerilliant Analytical Reference Materials. 811 Paloma Drive, Suite A, Round Rock, Texas 78664 (www.cerilliant.com).
- [20] The National Alliance for Model State Drug Laws (NAMSDL) [2007]. State Controlled Substance(s) Environmental Issues Bill – Status Update [<http://www.namsdl.org/>]. Date accessed: March 11, 2008.
- [21] Howard PH, Meylan WM [1997]. *Handbook of physical properties of organic chemicals*. Boca Raton, Florida: CRC/Lewis Publishers. See also Syracuse Research Corporation's website <http://www.srcinc.com/> (May 10, 2004) for demos and updates.
- [22] Zhang JS, Tian Z, Lou ZC [1989]. Quality evaluation of twelve species of chinese ephedra (Ma Huang). *Acta Pharmaceutic Sinica* 24(11):865-871.
- [23] Cui JF, Zhou TH, Zhang JS, and Lou ZC. [1991]. Analysis of alkaloids in chinese ephedra species by gas chromatographic methods. *Phytochemical Analysis* 2:116-119.
- [24] Andrews KM [1995]. Ephedra's role as a precursor in the clandestine manufacture of methamphetamine. *Journal of Forensic Sciences* 40(4):551-560.
- [25] OSHA [2001]. Evaluation guidelines for surface sampling methods. Industrial Hygiene Chemistry Division, OSHA Salt Lake Technical Center, Salt Lake City, Utah. [<http://www.osha.gov/dts/sltc/methods/surfacesampling/surfacesampling.pdf>] Date accessed: May 2011.

METHOD DEVELOPMENT BY:

John M. Reynolds, Maria Carolina Siso, and James B. Perkins, DataChem Laboratories, Inc., Salt Lake City, Utah under NIOSH Contract CDC 200-2001-0800.

Disclaimer: Mention of any company or product does not constitute endorsement by NIOSH. In addition, citations to websites external to NIOSH do not constitute NIOSH endorsement of the sponsoring organizations or their programs or products. Furthermore, NIOSH is not responsible for the content of these websites. All web addresses referenced in this document were accessible as of the publication date.

Table 1. Formula and registry numbers of analytes.

| Compound (alphabetically) | MW ⁽¹⁾ (Daltons) | | | Structural Formula As free base | CAS # ⁽²⁾ | RTECS ⁽⁶⁾ |
|--------------------------------------|-----------------------------|----------|---------------------|---|--|-------------------------------------|
| | Free base | HCl salt | Hemisulfate salt | | | |
| (DL)-Amphetamine | 135.21 | 171.67 | 184.25 | $C_6H_5 \cdot CH_2 \cdot CH(CH_3) \cdot NH_2$ | 300-62-9 ⁽³⁾ 60-13-9 ⁽⁵⁾ | SH9450000 SI1750000 |
| (D)-Amphetamine ⁽⁷⁾ | 135.21 | 171.67 | 184.25 | $C_6H_5 \cdot CH_2 \cdot CH(CH_3) \cdot NH_2$ | 51-64-9 ⁽³⁾ 51-63-8 ⁽⁵⁾ | SI1400000 |
| (L)-Amphetamine | 135.21 | 171.67 | 184.25 | $C_6H_5 \cdot CH_2 \cdot CH(CH_3) \cdot NH_2$ | 156-34-3 ⁽³⁾ | SH9050000 |
| Caffeine | 194.19 | | | $(CH_3)_3 \cdot [C_5HN_4O_2]$ | 58-08-2 ⁽³⁾ | EV6475000 |
| (DL)-Ephedrine | 165.24 | 201.70 | 214.28 | $C_6H_5 \cdot CH(OH) \cdot CH(CH_3) \cdot NH \cdot CH_3$ | 90-81-3 ⁽³⁾ 134-71-4 ⁽⁴⁾ | |
| (L)-Ephedrine ⁽⁸⁾ | 165.24 | 201.70 | 214.28 | $C_6H_5 \cdot CH(OH) \cdot CH(CH_3) \cdot NH \cdot CH_3$ | 299-42-3 ⁽³⁾ 50-98-6 ⁽⁴⁾ 134-72-5 ⁽⁵⁾ | KB0700000 KB1750000 KB2625000 |
| (D)-Ephedrine | 165.24 | 201.70 | 214.28 | $C_6H_5 \cdot CH(OH) \cdot CH(CH_3) \cdot NH \cdot CH_3$ | 321-98-2 ⁽³⁾ 24221-86-1 ⁽⁴⁾ | KB0600000 KB1925000 |
| (±)-MDEA | 207.27 | 243.73 | | $CH_2O_2C_6H_3 \cdot CH_2 \cdot CH(CH_3) \cdot NH \cdot C_2H_5$ | 82801-81-8 ⁽³⁾ 116261-63-2 ⁽⁴⁾ | |
| (±)-MDMA | 193.24 | 229.71 | | $CH_2O_2C_6H_3 \cdot CH_2 \cdot CH(CH_3) \cdot NH \cdot CH_3$ | 42542-10-9 ⁽³⁾ 92279-84-0 ⁽⁴⁾ | SH5700000 |
| (+)-MDMA ⁽⁷⁾ | 193.24 | 229.71 | | $CH_2O_2C_6H_3 \cdot CH_2 \cdot CH(CH_3) \cdot NH \cdot CH_3$ | 64057-70-1 ⁽⁴⁾ | SH5700000 |
| (DL)-Methamphetamine | 149.24 | 185.70 | 198.28 | $C_6H_5 \cdot CH_2 \cdot CH(CH_3) \cdot NH \cdot CH_3$ | 4846-07-5 ⁽³⁾ | |
| (D)-Methamphetamine ⁽⁷⁾ | 149.24 | 185.70 | 198.28 | $C_6H_5 \cdot CH_2 \cdot CH(CH_3) \cdot NH \cdot CH_3$ | 537-46-2 ⁽³⁾ 51-57-0 ⁽⁴⁾ | SH4910000 SH5455000 |
| (L)-Methamphetamine | 149.24 | 185.70 | 198.28 | $C_6H_5 \cdot CH_2 \cdot CH(CH_3) \cdot NH \cdot CH_3$ | 33817-09-3 ⁽³⁾ | SH4905000 |
| Phencyclidine | 243.39 | 279.85 | | $C_6H_5 \cdot C[C_5H_{10}] \cdot N[C_5H_{10}]$ | 77-10-1 ⁽³⁾ 956-90-1 ⁽⁴⁾ | TN2272600 TN2272600 |
| Phentermine | 149.24 | 185.70 | | $C_6H_5 \cdot CH_2 \cdot C(CH_3)_2 \cdot NH_2$ | 122-09-8 ⁽³⁾ 1197-21-3 ⁽⁴⁾ | SH4950000 |
| (DL)-Norephedrine | 151.21 | 187.67 | 200.25 | $C_6H_5 \cdot CH(OH) \cdot CH(CH_3) \cdot NH_2$ | 14838-15-4 ⁽³⁾ 154-41-6 ⁽⁴⁾ | RC2625000 DN4200000 |
| 1R,2S (-)-Norephedrine | 151.21 | 187.67 | 200.25 | $C_6H_5 \cdot CH(OH) \cdot CH(CH_3) \cdot NH_2$ | 492-41-1 ⁽³⁾ | RC2275000 |
| 1S,2R (+)-Norephedrine | 151.21 | 187.67 | 200.25 | $C_6H_5 \cdot CH(OH) \cdot CH(CH_3) \cdot NH_2$ | 37577-28-9 ⁽³⁾ | |
| 1S,2S (+)-Norephedrine | 151.21 | 187.67 | 200.25 | $C_6H_5 \cdot CH(OH) \cdot CH(CH_3) \cdot NH_2$ | 36393-56-3 2153-98-2 ⁽⁴⁾ 492-39-7 ⁽⁴⁾ | RC9275000 |
| (D)-Pseudoephedrine ^(8,9) | 165.24 | 201.70 | 214.28 | $C_6H_5 \cdot CH(OH) \cdot CH(CH_3) \cdot NHCH_3$ | 90-82-4 ⁽³⁾ 345-78-8 ⁽⁴⁾ | UL5800000 UL5950000 |
| (L)-Pseudoephedrine ⁽¹⁰⁾ | 165.24 | 201.70 | 214.28 | $C_6H_5 \cdot CH(OH) \cdot CH(CH_3) \cdot NH \cdot CH_3$ | 321-97-1 ⁽³⁾ | |

(1) Molecular weights are calculated from the empirical formula using the 1987 IUPAC Atomic Weights of the Elements, Merck Index [9]. The molecular weight of the hemisulfate is ½ the weight of the 2:1 sulfate salt (2 moles amine + 1 mole H₂SO₄).

(2) CAS from various sources: Merck Index [14], NIOSH RTECS [17], MSDS sheets from Sigma/Aldrich [18], Cerilliant [19], and other sources [21].

(3) Free base form.

(4) Hydrochloride salt.

(5) 2:1 Sulfate salt (2 moles amine + 1 mole H₂SO₄).

(6) RTECS = NIOSH Registry of Toxic Effects of Chemical Substances [17].

(7) More active isomer.

(8) Naturally occurring isomer.

(9) The D form of pseudoephedrine is a decongestant.

(10) The L form of pseudoephedrine is a bronchodilator. Dehydroxylation forms the less active L-methamphetamine.

Table 2. Physical properties of analytes⁽¹⁾

| Compound (alphabetically) | CAS | m.p.(°C) | Vapor Pressure (mm Hg) | pK _a ⁽⁴⁾ | Log P ⁽⁵⁾ | Solubility in Water, g/100 mL |
|-----------------------------|------------|------------------------|---------------------------|---|----------------------|----------------------------------|
| (DL)-Amphetamine | 300-62-9 | — | — | 10.1 @ 20°C | 1.76 | 2.8 @ 25°C |
| (D)-Amphetamine | 51-64-9 | <25 | — | 9.9 | 1.76 | — |
| (D)-Amphetamine sulfate | 51-63-8 | >300 | — | — | 6.81 | — |
| (L)-Amphetamine | 156-34-3 | — | 0.201 @ 25°C | 10.1 @ 20°C | 1.76 | 2.8 @ 25°C |
| Caffeine | 58-08-2 | 238 | 15 @ 89°C | 10.4 @ 40°C | -0.07 | 2.16 @ 25°C |
| (DL)-Ephedrine | 90-81-3 | 76.5 | — | — | 0.68 | — |
| (L)-Ephedrine | 299-42-3 | 34 | 0.00083 @ 25°C | 10.3 @ 0°C | 1.13 | 6.36 @ 30°C |
| (L)-Ephedrine HCl | 50-98-6 | 218 | 2.04E-10 @ 25°C | pH 5.9 @ 1/200 dil. ⁽³⁾ | -2.45 | 25 ⁽⁶⁾ |
| MDEA | 82801-81-8 | — | — | — | — | — |
| MDMA HCl | 42542-10-9 | 148-149 ⁽²⁾ | — | — | — | — |
| (D)-Methamphetamine | 537-46-2 | — | 0.163 @ 25°C | 9.87 @ 25°C | 2.07 | 1.33 @ 25°C |
| (D)-Methamphetamine HCl | 51-57-0 | 170-175 ⁽²⁾ | — | — | — | — |
| Phencyclidine | 77-10-1 | 46.5 | — | 8.29 | 4.69 | — |
| Phencyclidine HCl | 956-90-1 | 233-235 ⁽²⁾ | — | — | — | — |
| Phentermine | 122-09-8 | — | 0.0961 @ 25°C | — | 1.90 | 1.86 @ 25°C |
| Phentermine HCl | 1197-21-3 | 198 ⁽²⁾ | — | — | — | — |
| (±) Phenylpropanolamine | 14838-15-4 | — | 0.000867 @ 25°C | 9.44 @ 20°C | 0.67 | 14.9 @ 25°C |
| (±) Phenylpropanolamine HCl | 154-41-6 | 194 | — | — | -2.75 | — |
| (L)-Norephedrine | 492-41-1 | 51-53 ⁽³⁾ | — | — | — | — |
| 1S,2S (+)-Norephedrine | 36393-56-3 | 77.5-78 | 0.000867 @ 25°C | 9.44 @ 20 | 0.83 | 14.9 @ 25 |
| 1S,2S (+)-Norephedrine HCl | 492-39-7 | — | — | pH 5.9-6.1 in aq. soln. ⁽³⁾ | 0.22 | 2 @ 25 |
| (D)-Pseudoephedrine | 90-82-4 | 119 | 0.00083 @ 25°C | 10.3 @ 0°C | 0.89 | 10.6 @ 25°C |
| (D)-Pseudoephedrine HCl | 345-78-8 | 181-182 ⁽²⁾ | — | pH 5.9 @ 1/200 dil. ⁽³⁾ | — | — |

(1) Handbook of Physical Properties of Organic Chemicals unless otherwise noted [21].

(2) Merck Index [14].

(3) Sigma-Aldrich MSDS [18].

(4) Negative log of the acid dissociation constant for the amine in aqueous solution.

(5) Log P = octanol-water partition coefficient.

(6) Temperature not given in source.

Table 3. Synonyms of analytes

| Generic names ⁽¹⁾ | Trade and street names ⁽²⁾ | Additional names ⁽³⁾ |
|---|--|---|
| (DL)-Amphetamine; (±)-Amphetamine (D)-Amphetamine; (+)-Amphetamine (L)-Amphetamine; (-)-Amphetamine Caffeine | Benzedrine; Phenedrine; Bennies Dextroamphetamine; Dexedrine; dexies Levoamphetamine; component of Adderall Component (with ephedrine) of cloud 9 and herbal XTC | (±)- α -Methylbenzeneethanamine ⁽⁴⁾ ; dl- α -Methylphenethylamine ⁽⁴⁾ ; dl-1-Phenyl-2-aminopropane; (±)-Desoxynorephedrine (S)- α -Methylbenzeneethanamine ⁽⁴⁾ ; d- α -Methylphenethylamine ⁽⁴⁾ ; d-1-phenyl-2-aminopropane; d- β -Phenylisopropylamine (R)- α -Methylbenzeneethanamine ⁽⁴⁾ ; l- α -Methylphenethylamine ⁽⁴⁾ ; l-1-phenyl-2-aminopropane; (-)-1-phenyl-2-aminopropane 3,7-Dihydro-1,3,7-trimethyl-1H-purine-2,6-dione ⁽⁴⁾ ; 1,3,7-Trimethylxanthine |
| (DL)-Ephedrine; (±)-Ephedrine (L)-Ephedrine; (-)-Ephedrine; (1R,2S)-(-)-Ephedrine; l-Ephedrine (D)-Ephedrine MDEA | Ephedral; Racephedrine; Sanedrine Primatene; Xenadrine; Ma Huang (Ephedra sinica and other species ⁽⁵⁾); (with caffeine) cloud 9 and herbal ecstasy MDE; Eve | (R*,S*)-(±)- α -[2-(Methylamino)ethyl]benzenemethanol; DL- α -[1-(Methylamino)ethyl]benzyl alcohol; dl-Ephedrine (R-(R*,S*))- α -(1-Methylaminoethyl)benzenemethanol; L-erythro-2- (Methylamino)-1-phenylpropan-1-ol; (1R,2S)-(-)-2-Methylamino-1- phenyl-1-propanol; (-)- α -(1-Methylamino-ethyl)-benzyl alcohol; (-)-1-hydroxy-2-methylamino-1-phenylpropane; L(-)-Ephedrine (1S,2R)-(+)-2-Methylamino-1-phenyl-1-propanol; (+)-Ephedrine (±)-3,4-Methylenedioxy-N-ethylamphetamine; N-ethyl- α -methyl-1,3-benzodioxole-5-ethanamine N, α -Dimethyl-3,4-1,3-benzodioxole-5-ethanamine; 3,4-Methylenedioxymethamphetamine N, α -Dimethylbenzeneethanamine ⁽⁴⁾ ; N, α -Dimethylphenethylamine; dl-Desoxyephedrine; N-methyl- β -phenylisopropylamine (S)-N, α -Dimethylbenzeneethanamine; (S)-(+)-N, α -Dimethyl- phenethylamine ⁽⁴⁾ ; d-1-Phenyl-2-methylaminopropane; d-Desoxyephedrine; d-N-methyl- β -phenyl-isopropylamine (R)-(-)-N, α -Dimethylphenethylamine; (-)-Deoxyephedrine; (-)-2-(Methylamino)-1-phenylpropane 1-(1-Phenylcyclohexyl) piperidine ⁽⁴⁾ |
| MDMA | Adam, ecstasy, X, XTC | |
| (DL)-Methamphetamine; (±)-Methamphetamine (D)-Methamphetamine; (+)-Methamphetamine; d-Methamphetamine (L)-Methamphetamine; (-)-Methamphetamine Phencyclidine | Methedrine; Desoxyn; chalk; crank; crystal; glass; ice; meth, speed; upper Component in decongestant vapor inhaler (Vick's brand) Sernylan; Sernyl; angel dust; PCP; peace pill | |
| Phentermine | Fastin; Normephtermin | α,α -Dimethylbenzeneethanamine ⁽⁴⁾ ; α,α -Dimethylphenethylamine ⁽⁴⁾ ; 1,1-Dimethyl-2-phenylethylamine; α -Benzylisopropylamine (R*,R*)-(±)- α -(1-Aminoethyl)benzenemethanol ⁽⁴⁾ ; -(±)- α -(1-Amino- ethyl)benzyl alcohol ⁽⁴⁾ ; (±)-2-Amino-1-phenyl-1-propanol (1R,2S)- 2-Amino-1-phenyl-1-propanol; (1R,2S)-Norephedrine; l-erythro-2-Amino-1-phenylpropan-1-ol (1S,2R)- 2-Amino-1-phenyl-1-propanol; (1S,2R)-Norephedrine; d-erythro-2-Amino-1-phenylpropan-1-ol (R*,R*)- α -(1-Aminoethyl)benzenemethanol ⁽⁴⁾ ; d-threo- α -2-Amino-1- hydroxy-1-phenylpropane; 1S,2S-(+)-Norpseudoephedrine (S-(R*,R*))- α -[1-(Methylamino)ethyl]benzenemethanol; (1S,2S)- (+)-2-Methylamino-1-phenylpropanol; d-(α -(1-Methylamino)- ethyl)benzyl alcohol; (1S,2S)-(+)-Pseudoephedrine; d-threo-2- Methylamino-1-phenylpropan-1-ol; (+)- ψ -Ephedrine (1R,2R)-(-)-Pseudoephedrine; (-)- ψ -Ephedrine; l-threo-2- Methylamino-1-phenylpropan-1-ol; (+)- ψ -Ephedrine |
| (DL)-Norephedrine; (±)-Norephedrine (L)-Norephedrine; (-)-Norephedrine (D)-Norephedrine; (+)-Norephedrine (+)-Norpseudoephedrine; Cathine L-(+)-Pseudoephedrine; (+)-Pseudoephedrine; d-Pseudoephedrine | (±)-Phenylpropanolamine; Obestat; Phenedrine; Natural form found in Ephedra sinica and other species ⁽⁵⁾ Metabolite of cathinone in urine of Khat users. Amorphan; Adiposettin; Reduform; found naturally in Khat plant Afrinol; Novafed; Sinufed; Sudafed; natural form found in Ephedra sinica and other species ⁽⁵⁾ | |
| D-(-)-Pseudoephedrine; (-)-Pseudoephedrine | | |

(1) Common or generic names. Salts forms are not given for simplicity.

(2) Trade and street names are exemplary, not exhaustive. Street names change over time and by locality. Salts and free base forms are not distinguished.

(3) Other names from Merck Index [14], NIOSH Registry of Toxic Effects of Chemical Substances [17], and MSDS sheets [19] and other reference materials [20]. NOTE: For amphetamine and methamphetamine the prefixes R-, D-, d-, and (+)-, although they mean different things, are essentially synonymous for the dextrorotatory stereoisomer and S-, L-, l-, and (-) are essentially synonymous for the levorotatory stereoisomer. Many other synonyms exist.

(4) Uninverted CAS name as given in Merck Index [14].

(5) Extracts of Ephedra species contain various amounts of (+)-Norephedrine, (-)-N-methylephedrine, and (+)-N-methylpseudoephedrine. (+)-Norephedrine is reduced to amphetamine and N-methylephedrine and N-methylpseudoephedrine reduce to N,N-dimethylamphetamine [23, 24]. The presence of these latter two compounds in methamphetamine samples indicate that Ephedra spp. extracts may have been used in the synthesis [25].

Table 4. Limit of detection (LOD), method detection limit (MDL), and sample storage stability on cotton gauze. ⁽¹⁾

| Compound | Int. std. ⁽²⁾ | Estimated LOD ⁽³⁾ | | Estimated MDL ⁽⁴⁾ | | Storage Stability ⁽⁵⁾ | |
|---------------------------------|--------------------------|------------------------------|-------------------------|------------------------------|-------------------------|----------------------------------|--------------|
| | | Scan Mode (µg/sample) | SIM Mode (µg/sample) | Scan Mode (µg/sample) | SIM Mode (µg/sample) | 30 days 4 °C | 7 days 22 °C |
| (D)-Amphetamine | D11-Amp | 0.07 | 0.05 | 0.04 | 0.02 | 100.5 | 94.5 |
| | D14-Met | 0.06 | 0.06 | 0.03 | 0.03 | 99.7 | 87.9 |
| Caffeine | D11-Amp | 1 | 0.2 | 0.4 ⁽⁶⁾ | 0.02 | 99.3 | 98.8 |
| | D14-Met | 1 | 0.2 | 0.4 ⁽⁶⁾ | 0.03 | 98.5 | 91.9 |
| (L)-Ephedrine | D11-Amp | 0.09 | 0.1 | 0.02 | 0.01 | 95.6 | 97.2 |
| | D14-Met | 0.08 | 0.09 | 0.01 | 0.06 | 94.8 | 90.5 |
| MDEA | N-Pamp | 0.05 | 0.07 | 0.1 | 0.02 | 98.9 | 102.1 |
| MDMA | D11-Amp | 0.05 | 0.06 | 0.04 | 0.02 | 99.7 | 111.1 |
| | D14-Met | 0.05 | 0.07 | 0.03 | 0.02 | 98.9 | 103.2 |
| (D)-Methamphetamine | D11-Amp | 0.07 | 0.05 | 0.03 | 0.02 | 98.7 | 100.6 |
| | D14-Met | 0.05 | 0.05 | 0.03 | 0.02 | 98.0 | 93.5 |
| Phencyclidine | D11-Amp | 0.3 | 0.06 | 0.03 | 0.02 | 103.7 | 105.2 |
| | D14-Met | 0.3 | 0.07 | 0.03 | 0.02 | 102.9 | 97.7 |
| Phentermine | D11-Amp | 0.06 | 0.05 | 0.02 | 0.02 | 102.0 | 101.5 |
| | D14-Met | 0.05 | 0.05 | 0.02 | 0.02 | 101.1 | 94.3 |
| | | 0.06 | 0.05 | 0.01 | | | |
| (±)-Norephedrine ⁽⁷⁾ | D11-Amp | 0.2 | ⁽⁸⁾ | 0.1 ⁽⁹⁾ | ⁽⁸⁾ | 94.3 | 92.7 |
| | D14-Met | 0.2 | | 0.2 ⁽¹⁰⁾ | ⁽⁸⁾ | 93.6 | 86.2 |
| Pseudoephedrine | D11-Amp | 0.08 | 0.07 | 0.03 | 0.02 | 100.4 | 97.9 |
| | D14-Met | 0.07 | 0.09 | 0.05 | 0.03 | 99.6 | 91.1 |
| | NMPhen | 0.06 | 0.09 | 0.05 | 0.02 | - | - |

(1) Backup Data Report [4].

(2) Internal standards: D11-Amp = Amphetamine-D₁₁, D14-Met = Methamphetamine-D₁₄, NMPhen = N-Methyl phenethylamine, N-Pamp = N-Propyl amphetamine.

(3) LODs vary according to individual GC columns, instrument conditions and cleanliness, media interferences, and internal standards used. The lowest calibration standard for these determinations was 0.05 µg/sample. Lower LODs are achievable with lower concentration calibration standards and operation of the mass spectrometer in the SIM mode. LODs were calculated on liquid standards using the procedure of Burkart [12].

(4) MDLs are provided as an alternate expression of sensitivity. These MDLs are calculated as the standard deviation of six replicates on spiked media analyzed at the 0.1 µg/sample level (except as noted) times the Student's t value for 6 replicates (3.365). (Normally 7 replicates are used.)

(5) Cotton gauze samples were spiked at 3 µg/sample per analyte. Six samples were analyzed immediately after preparation. Six samples were stored at room temperature (about 22 °C) for 7 days and then analyzed. Eighteen samples were stored at +4 °C (±2 °C). Of the 18 samples stored at +4 °C, six each were analyzed at 7 and 21 days and three each were analyzed at 14 and 30 days. (Backup Data Report [4].) Apparent recoveries vary according to internal standard used.

(6) The 0.3 µg/sample level was undetectable in the scan mode. MDLs were calculated from the 1 µg/sample level.

(7) (±)-Norephedrine = (±)-phenylpropanolamine.

(8) (±)-Norephedrine was not evaluated in the SIM mode due to breakdown of derivative with room temperature storage for one week.

(9) MDL calculated from the 0.3 µg/sample level. (Recoveries were >120% at the 0.1 µg/sample level.)

(10) MDL calculated from the 1 µg/sample level. (Recoveries were >120% at the 0.1 and 0.3 µg/sample levels.)

Table 5. Example of mass spectrometer operation parameters for selected ion monitoring mode.⁽¹⁾

| Chlorodifluoroacetyl derivatives | | Scan window ⁽²⁾ | Acquisition ions (<i>m/z</i>) per group ⁽³⁾ | | | | | | | |
|----------------------------------|--|----------------------------|--|-----|-----|-----|-----|-----|-----|-----|
| Acquisition Group 1 | | 10.5 to 13.0 | 104 | 118 | 128 | 156 | 160 | 170 | 172 | 177 |
| Acquisition Group 2 | | 13.0 to 15.2 | 104 | 156 | 158 | 170 | 172 | 198 | 296 | |
| Acquisition Group 3 | | 15.2 to 18.0 | 109 | 135 | 162 | 170 | 184 | 194 | 200 | 242 |

| GC Peak No. ⁽⁴⁾ | Target Analytes and Internal Standards: ⁽⁵⁾ | Retention Time ⁽⁶⁾ (min) | Primary Ion (<i>m/z</i>) ⁽⁷⁾ (Quantification Ion) | Secondary ion and approximate relative abundance ⁽⁸⁾ (relative to the Primary Ion) | |
|----------------------------|--|-------------------------------------|--|---|------|
| Acquisition Group 1 | | | | | |
| 2 | Amphetamine-D ₁₁ (IS) ⁽⁹⁾ | 11.07 | 160 | 128 | 85% |
| 3 | Amphetamine | 11.15 | 156 | 118 | 85% |
| 5 | Phentermine | 11.34 | 170 | 172 | 33% |
| 8 | n-Methyl phenethylamine (IS) ⁽⁹⁾ | 12.20 | 156 | 104 | 95% |
| 9 | Methamphetamine-D ₁₄ (IS) ⁽⁹⁾ | 12.51 | 177 | 128 | 32% |
| 10 | Methamphetamine | 12.61 | 170 | 118 | 32% |
| Acquisition Group 2: | | | | | |
| 18 | Phenylpropanolamine | 13.27 | 156 | 246 | 25% |
| 20 | Dibromooctafluorobiphenyl ⁽¹⁰⁾ | 13.63 | 296 | 456 | 115% |
| 21 | N-n-Propylamphetamine (IS) ⁽⁹⁾ | 13.8 | 198 | 156 | 75% |
| 25 | Ephedrine | 14.27 | 170 | 172 | 33% |
| 28 | Pseudoephedrine | 14.74 | 170 | 172 | 33% |
| Acquisition Group 3: | | | | | |
| 32 | Caffeine | 15.66 | 194 | 109 | 50% |
| 40 | Phencyclidine | 16.41 | 200 | 242 | 35% |
| 41 | MDMA | 16.48 | 170 | 162 | 95% |
| 43 | MDEA | 16.87 | 184 | 162 | 75% |

- (1) In this example, 10 analytes and 5 internal standards are grouped into 3 acquisition groups having no more than 8 primary and secondary ions per acquisition group. For 6 analytes and internal standards or less, one acquisition group may be sufficient.
- (2) Scan window is in minutes. Actual times are dependant upon GC column and instrument conditions.
- (3) Ions (*m/z*) in bold numbers are suggested primary (quantification) ions. For best signal to noise ratio, do not exceed 10 ions per acquisition group. Dwell times per ion (*m/z*) is 50 milliseconds.
- (4) GC peak numbers are those in Figure 1 and Table 9.
- (5) The list of analytes and internal standards shown is an example. Analyte(s) and internal standard(s) must be selected according to analytical objectives.
- (6) Retention times are dependant upon GC column and instrument conditions.
- (7) The better ions for quantification are usually the base peak or those with masses >100 *m/z* and relative abundances >50% of the base peak. These minimize interference from co-eluting hydrocarbons. The suggested primary ions are not necessarily the base peaks in the mass spectra of the analytes, especially if the base peaks are ions common to aromatics (e.g. *m/z* 91) and paraffinic or olefinic hydrocarbons (e.g. *m/z* 42, 57, and 58). Suggested ions for other analytes and internal standards are given in Tables 8 and 9.
- (8) Secondary ions may be used for quantification if the primary ion encounters interference. Secondary ions improve qualitative identification for SIM analyses. The relative abundances given are approximate (± 10 to 20%) and depend upon specific instrument tuning and conditions. They are relative to the primary ion and not necessarily to the base peak in the mass spectrum of each analyte. The relative abundance of secondary ions for each analyte needs to be determined from a mass spectrum acquired on the instrument to be used.
- (9) (IS) = internal standard. Internal standards must be paired with the appropriate analytes. Tables 7a and 7b give precision and accuracy data for various pairings. Other potentially useful internal standards are given in Table 8. Highly deuterated analogs of the target analytes are preferred, where available.
- (10) Dibromooctafluorobiphenyl is an optional secondary internal standard useful for monitoring autosampler performance and instrument tuning. A shift in the mass axes or the relative abundance of *m/z* 296 to that of *m/z* 456 throughout an analytical sequence will help signal degraded tuning.

Table 6. Suggested spiking schedule for calibration standards and quality control samples

| Add the following to clean shipping containers (e.g. 50-mL polypropylene centrifuge tubes) in the following order. | | | | | | | |
|---|----------------------------------|---|--|--|--|---|---|
| Calibration Standards ⁽¹⁰⁾ | Number of Wipes ^(1,2) | Volume ⁽²⁾ of Isopropanol or Methanol ⁽³⁾ | Volume ⁽²⁾ of Internal Standard Spiking Solution ^(4,5) | Volume of Target Analyte Spiking Solution ^(5,6) | Volume of Spiking Solution diluted 1/20 ^(5,7) | Volume ⁽²⁾ of Desorption Solution ⁽⁸⁾ | Resulting µg/sample as Free Base ⁽⁹⁾ |
| CS0 | 0 | 3 mL | 60 µL | | 0.0 µL | 30 mL | 0.00 |
| CS1 | 0 | 3 mL | 60 µL | | 2 µL | 30 mL | 0.02 |
| CS2 | 0 | 3 mL | 60 µL | | 5 µL | 30 mL | 0.05 |
| CS3 | 0 | 3 mL | 60 µL | | 10 µL | 30 mL | 0.1 |
| CS4 | 0 | 3 mL | 60 µL | | 20 µL | 30 mL | 0.2 |
| CS5 | 0 | 3 mL | 60 µL | | 60 µL | 30 mL | 0.6 |
| CS6 | 0 | 3 mL | 60 µL | 10 µL | | 30 mL | 2.0 |
| CS7 | 0 | 3 mL | 60 µL | 30 µL | | 30 mL | 6.0 |
| CS8 | 0 | 3 mL | 60 µL | 100 µL | | 30 mL | 20 |
| CS9 | 0 | 3 mL | 60 µL | 300 µL | | 30 mL | 60 |
| CS10 | 0 | 3 mL | 60 µL | 1000 µL | | 30 mL | 200 |
| Quality Control Samples ⁽¹¹⁾ | | | | | | | |
| QB (media blank) | 1 | 3 mL | 60 µL | 0.0 µL | | 30 mL | 0.0 |
| QC (matrix spike) | 1 | 3 mL | 60 µL | 3-300 µL | or 20-60 µL | 30 mL | 0.2-60 |
| QD (matrix spike duplicate) | 1 | 3 mL | 60 µL | 3-300 µL | or 20-60 µL | 30 mL | 0.2-60 |

- (1) Gauze wipes may be added to the calibration standards but are not necessary if cotton gauze is used. Blank gauze wipes must always be added to the quality control samples, QB, QC, and QD.
- (2) a.) If a sample consists of 2 gauze wipes, the volume of desorption solution must be increased to 40 mL to accommodate the second wipe. The shipping container should be a 50-mL polypropylene centrifuge tube or equivalent to accommodate the extra volume of desorption solution for 2 wipes. It is not critical to know the exact volume of desorption solution and wetting alcohol used per sample. It only needs to be enough to cover the samples and to permit free percolation through the samples. See step 7.
b.) If a set of samples consists predominantly of 2 gauze wipes, the QB, QC, and QD should also consist of 2 wipes and treated as per the samples. The volume of isopropanol (or methanol) added to the QC samples should be increased to 4 mL for two gauze wipes to simulate samples containing two gauze wipes.
- (3) If methanol was used for wipe sampling, it should also be used in the calibration standards, blanks, and QCs instead of isopropanol.
- (4) Concentration of internal standards in the internal standard spiking solution is approximately 200 µg/mL as the free base. It is critical to know the exact volume of internal standard spiking solution that is added to the calibration standards, samples, blanks, and quality control samples. The volume spiked into the samples may vary with sample size but the volume spiked into each of the calibration standards must not vary. See step 7b.
- (5) For quality control samples, spike onto wipe media within the shipping container. For liquid calibration standards (in lieu of media calibration standards), spike into the isopropanol (or methanol).
- (6) Concentration of analytes in the target analyte spiking solution is approximately 200 µg/mL as the free base.
- (7) Concentration of analytes in the diluted spiking solution for this table is approximately 10.0 µg/mL as the free base and can be prepared by diluting 100 µL of the target analyte spiking solution to 2 mL in methanol.
- (8) Desorption solution is 0.1 M sulfuric acid in deionized water.
- (9) This is µg per total sample irrespective of the total desorption solution volume or the area wiped.
- (10) Select 6 calibration standards from the list to cover the analytical range plus the blank.
- (11) Prepare one set of quality control samples for every 20 samples or less.

Table 7a. Precision and accuracy in scan mode.⁽¹⁾

| Compound | Internal Standard ⁽²⁾ | Range ⁽³⁾ µg/sample | Accuracy | Overall Precision \bar{S}_{RT} | Bias | |
|---------------------------------|----------------------------------|-----------------------------------|----------|-------------------------------------|---------|--------------------|
| | | | | | Average | Range |
| (D)-Amphetamine | D11-Amp | 0.1-30 | 17.1 | 0.0670 | -0.0613 | -0.1048 - -0.0170 |
| | D14-Met | 0.1-30 | 13.7 | 0.0610 | +0.0338 | -0.0151 - +0.1056 |
| | NMPhen | 0.1-30 | 12.5 | 0.0559 | -0.0310 | -0.0651 - +0.0177 |
| Caffeine | D11-Amp | 1.0-30 | 20.0 | 0.0708 | -0.0832 | - 0.1476 - -0.0542 |
| | D14-Met | 1.0-30 | 12.5 | 0.0636 | -0.0014 | - 0.0274 - +0.0381 |
| | NMPhen | 1.0-30 | 15.6 | 0.0796 | -0.0040 | -0.0789 - +0.1321 |
| (L)-Ephedrine | D11-Amp | 0.1-10 | 15.4 | 0.0627 | +0.0510 | -0.0148 - +0.1128 |
| | D14-Met | 0.3-10 | 17.8 | 0.0674 | +0.0666 | +0.0261 - +0.1660 |
| | NMPhen | 0.3-30 | 15.0 | 0.0707 | +0.0293 | -0.0259 - +0.0973 |
| MDEA | N-PAmp | 0.3-29 | 16.6 | 0.0817 | -0.0224 | -0.0656 - +0.0657 |
| MDMA | D11-Amp | 0.3-27 | 20.2 | 0.0778 | -0.0739 | -0.1011 - -0.0489 |
| | D14-Met | 0.3-27 | 16.6 | 0.0652 | +0.0589 | -0.0947 - +0.0036 |
| | NMPhen | 0.3-27 | 22.0 | 0.0722 | -0.1017 | -0.1486 - -0.0315 |
| (D)-Methamphetamine | D11-Amp | 0.1-30 | 14.7 | 0.0631 | -0.0435 | -0.0657 - -0.0060 |
| | D14-Met | 0.1-30 | 12.5 | 0.0546 | -0.0348 | -0.1144 - +0.0188 |
| | NMPhen | 0.1-10 ⁽⁵⁾ | 14.9 | 0.0503 | -0.0665 | -0.1179 - +0.0110 |
| Phencyclidine | D11-Amp | 0.1-10 | 18.2 | 0.0690 | -0.0683 | -0.1257 - -0.0136 |
| | D14-Met | 0.3-3 | 13.4 | 0.0465 | -0.0577 | -0.0662 - -0.0493 |
| | NMPhen | 0.3-10 | 16.8 | 0.0609 | -0.0682 | -0.1137 - +0.0091 |
| Phentermine | D11-Amp | 0.1-30 | 15.2 | 0.0486 | -0.0720 | -0.1010 - +0.0291 |
| | D14-Met | 0.1-30 | 10.7 | 0.0509 | +0.0190 | -0.0395 - +0.0671 |
| | NMPhen | 0.1-30 | 9.6 | 0.0420 | -0.0269 | -0.0612 - +0.0340 |
| (±)-Norephedrine ⁽⁴⁾ | D11-Amp | 1-30 | 6.5 | 0.0328 | +0.0061 | -0.0070 - +0.0248 |
| Pseudoephedrine | D11-Amp | 0.3-30 | 17.2 | 0.0571 | -0.0783 | -0.1273 - -0.0560 |
| | D14-Met | 0.3-30 | 14.9 | 0.0649 | -0.0422 | -0.0888 - +0.0395 |
| | NMPhen | 0.3-30 | 18.7 | 0.0488 | -0.1068 | -0.1505 - -0.0422 |

(1) Backup Data Report [4]. Values are for chlorodifluoroacetyl derivatives and analysis by GC-MS in scan mode. Each sample consisted of a pair of 3" x 3" 12-ply cotton gauze pads. There were 6 replicate samples per concentration level and six concentration levels evaluated from approximately 0.1 to 30 µg/sample.

(2) Internal Standards Deuterated: D11-Amp = Amphetamine-D₁₁
 Non-deuterated: NMPhen = N-Methyl phenethylamine
 D14-Met = Methamphetamine-D₁₄ N-PAmp = N-Propyl amphetamine

(3) Range used for calculation of precision, accuracy, and bias. The entire range studied for all analytes was approximately 0.1 to 30 µg/sample (1xLOQ to 300xLOQ).

(4) (±)-Norephedrine = (±)-phenylpropanolamine.

(5) One or more higher level concentrations were omitted from the computations due to inlier CVs (<0.0200.)

Table 8a. Recommended internal standards and best application⁽¹⁾

| COMPOUND NAME | CAS | MW as free base | Quant. Ion | Secondary Ion | COMMENTS |
|-------------------------------------|---------------|-----------------|--------------------|--------------------|---|
| (±)-Amphetamine-D ₁₁ | Not available | 146.12 | 160 | 128 | Preferred analog for amphetamine |
| (±)-Amphetamine-D ₈ | 145225-00-9 | 143.15 | 126 ⁽³⁾ | 159 ⁽³⁾ | Alternate for amphetamine-D ₁₁ |
| (±)-Amphetamine-D ₆ | Not available | 141.16 | 160 | 123 | Alternate for amphetamine-D ₁₁ |
| (±)-Methamphetamine-D ₁₄ | Not available | 163.12 | 177 | 128 | Preferred methamphetamine analog |
| (±)-Methamphetamine-D ₁₁ | 152477-88-8 | 160.15 | 176 | 126 | Alternate for methamphetamine-D ₁₄ |
| (±)-Methamphetamine-D ₉ | Not available | 158.16 | 177 | 123 | Alternate for methamphetamine-D ₁₄ |
| N-Methylphenethylamine | 589-08-2 | 135.23 | 156 | 104 | Alternate for methamphetamine-D ₁₄ |
| Phencyclidine-D ₅ | 60124-86-9 | 248.35 | 205 | 247 | Use only for phencyclidine. |
| MDEA-D ₆ ⁽²⁾ | 160227-44-1 | 213.22 | 190 | 165 | Use only for MDEA. |
| N-Propylamphetamine ⁽²⁾ | Not available | 177.29 | 198 | 156 | Alternate for MDEA-D ₆ |

- (1) Care must be exercised in the selection of internal standards for each analyte because of differences in derivatization efficiencies due to structural differences.
 - a. Deuterated analogs of each target analyte may be acceptable as internal standards if they are isotopically pure enough and their ions do not interfere with the quantification ions (usually base peaks) of the target analyte, especially at the limit of detection for the target analyte. Conversely it is also important that ions in the target analyte, especially at high concentrations, do not interfere with the quantification ion (usually base peaks) of any deuterated analog used as the internal standard.
 - b. The more highly deuterated an analog, the more it will chromatographically separate from the target analyte, reducing interference from common ions.
 - c. Phentermine and mephentermine have been used as internal standards. Such use is not advised in this method because of their reported occasional use as adulterants in certain illicit drugs such as MDMA.
- (2) N-Propylamphetamine and MDEA-D₆ are only applicable to MDEA and other hindered amines (e.g. fenfluramine and MBDB) due to similar steric hindrance at the nitrogen (N-ethyl or N-propyl substitution) which affects derivatization efficiency.
- (3) It is better to use m/z 126 because at high concentration levels unlabelled amphetamine contributes significant interference to m/z 159 of amphetamine-D₈.

Table 8b. Recommended best application of internal standards

| TARGET ANALYTE | Recommended Deuterated Internal Standards | | | Recommended Alternate Non-deuterated Internal Standards ⁽³⁾ | | | |
|---------------------------------|---|---|------------------------------------|--|--------------------------|------------------------|--------------------------------------|
| | Amphet-amine-D ₁₁ ⁽²⁾ | Metham-phetamine-D ₁₄ ⁽²⁾ | MDEA-D ₆ ⁽¹⁾ | Phency-clidine-D ₅ | N-Methyl-phenethyl-amine | 4-Phenyl-1-butyl-amine | N-Propyl-amphet-amine ⁽¹⁾ |
| Amphetamine | X | X | | | X | | |
| Caffeine | | X | | | X | | |
| Ephedrine | X | X | | | X | X | |
| MDEA | | | X | | | | X |
| MDMA | | X | | | X | | |
| Methamphetamine | X | X | | | X | | |
| Phencyclidine | | X | | X | X | | |
| Phentermine | X | | | | X | | |
| (±)-Norephedrine ⁽⁴⁾ | X | | | | | X | |
| Pseudoephedrine | | X | | | X | | |

- (1) N-Propylamphetamine and MDEA-D₆ are only applicable to MDEA and other hindered amines (e.g. fenfluramine and MBDB) due to similar steric hindrance at the nitrogen (N-ethyl or N-propyl substitution) which affects derivatization efficiency.
- (2) The alternate deuterated compounds listed in part A above may be used. Avoid ring-labeled amphetamine-D₅ (CAS 65538-33-2) since the primary (quantification) ion is the same as for amphetamine and GC peaks overlap significantly. Also avoid methamphetamine-D₅ (CAS 60124-88-1) since GC peaks significantly overlap and secondary ions for the chlorodifluoroacetyl derivative are not baseline resolved.
- (3) The listed non-deuterated compounds are effective as internal standards for the listed target analytes. Non-deuterated internal standards might not be permissible.
- (4) (±)-Norephedrine is the same as (±)-phenylpropanolamine.

Table 9. Gas chromatographic retention times for chlorodifluoroacetyl derivatives of amphetamines, precursors, adulterants, and miscellaneous drugs of abuse.⁽¹⁾

| GC Peak No. ⁽²⁾ | Compound | Recommended Quantification (1') and Confirmation(2', 3') | | | Form ⁽⁴⁾ | Retention Time in Minutes | Relative Retention Time ⁽⁵⁾ | Relative Retention Time ⁽⁶⁾ |
|----------------------------------|---|---|-----|-----|----------------------------|---------------------------------|--|--|
| | | Ions (m/z) ⁽³⁾ | | | | | | |
| | | 1' | 2' | 3' | | | | |
| 1 | Nicotine | 84 | 133 | 162 | parent | 8.92 | 0.396 | 0.757 |
| 2 | (DL)-Amphetamine-D ₁₁ (I\$) ⁽⁷⁾ | 160 | 128 | 162 | derivative | 10.26 | 0.800 | 0.870 |
| 3 | (DL)-Amphetamine | 156 | 118 | 158 | derivative | 10.34 | 0.807 | 0.877 |
| 4 | Phenethylamine ⁽⁸⁾ | 104 | 91 | - | derivative | 10.38 | 0.810 | 0.880 |
| 5 | Phentermine ⁽⁸⁾ | 170 | 172 | 132 | derivative | 10.52 | 0.821 | 0.892 |
| 6 | N-Methyl pseudoephedrine ⁽⁹⁾ | 134 | 162 | 75 | derivative | 10.54 | 0.822 | 0.894 |
| 7 | N-Methyl pseudoephedrine ⁽⁹⁾ | 72 | - | - | parent | abt 11 | 0.86 | 0.93 |
| 8 | N-Methyl phenethylamine (I\$) ⁽⁷⁾ | 156 | 104 | 158 | derivative | 11.37 | 0.887 | 0.964 |
| 9 | (DL)-Methamphetamine-D ₁₄ (I\$) ⁽⁷⁾ | 177 | 98 | 179 | derivative | 11.70 | 0.913 | 0.992 |
| 10 | (DL)-Methamphetamine | 170 | 172 | 118 | derivative | 11.79 | 0.920 | 1.000 |
| 11 | Fenfluramine ⁽⁸⁾ | 184 | 186 | 159 | derivative | 11.83 | 0.923 | 1.003 |
| 12 | S(-)-Cathinone (from Khat plant) | 105 | 77 | 132 | derivative | 11.99 | 0.935 | 1.017 |
| 13 | Bupropion (Wellbutrin®, Zyban®) | 44 | 100 | 111 | parent | 12.14 | 0.947 | 1.030 |
| 14 | N-Ethyl amphetamine | 184 | 186 | 118 | derivative | 12.22 | 0.953 | 1.036 |
| 15 | Ecgonine, methyl ester | 182 | 82 | 311 | derivative | 12.36 | 0.964 | 1.048 |
| 16 | S(-)-Methcathinone ("Cat") | 170 | 105 | 172 | derivative | 12.38 | 0.966 | 1.050 |
| 17 | Norpseudoephedrine (Cathine) | 156 | 158 | 246 | bis-derivative | 12.46 | 0.972 | 1.057 |
| 18 | (±)-Norephedrine | 156 | 158 | 246 | bis-derivative | 12.49 | 0.974 | 1.059 |
| 19 | Aminorex | 107 | 79 | 232 | derivative (-CN) | 12.70 | 0.991 | 1.077 |
| 20 | Dibromooctafluorobiphenyl (I\$) ⁽⁷⁾ | 296 | 456 | 454 | parent | 12.82 | 1.000 | 1.087 |
| 21 | N-Propyl amphetamine (I\$) ⁽⁷⁾ | 198 | 156 | 200 | derivative | 12.97 | 1.012 | 1.100 |
| 22 | 4-Methoxyamphetamine | 121 | 148 | 78 | derivative | 13.22 | 1.031 | 1.121 |
| 23 | 4-Phenyl-1-butylamine (I\$) ⁽⁷⁾ | 176 | 104 | - | derivative | 13.27 | 1.035 | 1.126 |
| 24 | 1S,2R(+)-Ephedrine-D ₃ (I\$) ⁽⁷⁾ | 173 | 175 | 85 | derivative | 13.44 | 1.048 | 1.140 |
| 25 | (DL)-Ephedrine | 170 | 172 | 260 | bis-derivative | 13.48 | 1.052 | 1.143 |
| 26 | Acetaminophen ⁽⁸⁾ | 108 | 221 | 263 | derivative | 13.67 | 1.066 | 1.159 |
| 27 | Methyl phenidate (Ritalin®) | 84 | 56 | 91 | parent | 13.81 | 1.077 | 1.171 |
| 28 | Pseudoephedrine | 170 | 172 | 260 | bis-derivative | 13.93 | 1.087 | 1.182 |
| 29 | Meperidine (Demerol® etc.) | 71 | 247 | 172 | parent | 13.99 | 1.091 | 1.187 |
| 30 | Atropine | 124 | 94 | 103 | parent (-H ₂ O) | 14.25 | 1.112 | 1.209 |
| 31 | (±)-MDA | 135 | 162 | 291 | derivative | 14.36 | 1.120 | 1.218 |
| 32 | Caffeine ⁽⁸⁾ | 194 | 109 | 67 | parent | 14.84 | 1.158 | 1.259 |
| 33 | N,N-Dimethyltryptamine (DMT) | 58 | 129 | 102 | derivative | 14.97 | 1.168 | 1.270 |
| 34 | (±)-BDB | 135 | 176 | 170 | derivative | 15.11 | 1.179 | 1.282 |
| 35 | Ketamine ("special K") ^(8,11) | 180 | 182 | 209 | parent | 15.20 | 1.186 | 1.289 |
| 36 | Lidocaine ⁽⁸⁾ | 86 | 58 | 120 | parent | 15.28 | 1.192 | 1.296 |
| 37 | Trifluoromethylphenyl piperazine ⁽¹¹⁾ | 200 | 145 | 172 | derivative | 15.46 | 1.206 | 1.318 |
| 38 | Benzyl piperazine ⁽¹¹⁾ ("Legal XTC") | 91 | 197 | 175 | derivative | 15.54 | 1.202 | 1.318 |
| 39 | Phencyclidine-D ₅ (I\$) ⁽⁷⁾ | 205 | 96 | 246 | parent | 15.59 | 1.216 | 1.322 |
| 40 | Phencyclidine (PCP) | 200 | 242 | 243 | parent | 15.62 | 1.218 | 1.325 |
| 41 | MDMA ⁽¹¹⁾ | 170 | 162 | 135 | derivative | 15.66 | 1.221 | 1.328 |

Table 9 continued,

Table 9, continued. Gas chromatographic retention times for chlorodifluoroacetyl derivatives of amphetamines, precursors, adulterants, and miscellaneous drugs of abuse.⁽¹⁾

| GC Peak No. ⁽²⁾ | Compound | Recommended Quantification (1') | | | Form ⁽⁴⁾ | Retention Time Minutes | Relative Retention Time ⁽⁵⁾ | Relative Retention Time ⁽⁶⁾ |
|----------------------------|---|------------------------------------|-----|-----|---------------------|------------------------|--|--|
| | | and Confirmation | | | | | | |
| | | (2', 3') Ions (m/z) ⁽³⁾ | | | | | | |
| 1' | 2' | 3' | | | | | | |
| 42 | MDEA-D ₆ (I _S) ⁽⁷⁾ | 190 | 165 | 135 | derivative | 16.01 | 1.249 | 1.358 |
| 43 | MDEA ⁽¹¹⁾ | 184 | 162 | 135 | derivative | 16.04 | 1.251 | 1.360 |
| 44 | Phenylephrine ⁽⁸⁾ | 156 | 158 | 374 | tris-derivative | 16.10 | 1.256 | 1.366 |
| 45 | (±)-MBDB | 184 | 176 | 135 | derivative | 16.29 | 1.271 | 1.382 |
| 46 | Theophylline ⁽⁸⁾ | 180 | 95 | 68 | parent | 16.34 | 1.275 | 1.386 |
| 47 | Mescaline | 181 | 194 | 179 | derivative | 16.43 | 1.282 | 1.394 |
| 48 | Phenylephrine ⁽⁸⁾ | 156 | 248 | 158 | bis-derivative | 16.65 | 1.299 | 1.412 |
| 49 | Chlorpheniramine ⁽⁸⁾ | 203 | 205 | 167 | parent | 16.73 | 1.305 | 1.419 |
| 50 | Methyl phenidate | 196 | 198 | - | derivative | 17.20 | 1.322 | 1.459 |
| 51 | 4-Bromo-2,5-DMPEA ⁽¹⁰⁾ (Nexus) | 242 | 244 | 229 | derivative | 17.57 | 1.370 | 1.490 |
| 52 | cis-(±)-4-Methylaminorex ("U4Euh") | 203 | 160 | 117 | derivative | 17.89 | 1.396 | 1.517 |
| 53 | Dextromethorphan ⁽⁸⁾ | 271 | 59 | 150 | parent | 18.09 | 1.411 | 1.534 |
| 54 | Methaqualone | 235 | 250 | 233 | parent | 18.27 | 1.425 | 1.550 |
| 55 | Cocaine | 82 | 182 | 303 | parent | 18.62 | 1.452 | 1.579 |
| 56 | Atropine ⁽⁸⁾ | 124 | 82 | 94 | derivative | 19.10 | 1.490 | 1.620 |
| 57 | Diazepam (Valium [®] etc.) | 256 | 283 | 284 | parent | 20.76 | 1.619 | 1.761 |
| 58 | Hydrocodone (Lortab [®] etc.) | 299 | 242 | 284 | parent | 20.91 | 1.631 | 1.774 |
| 59 | Hydromorphone (Dilaudid [®]) | 285 | 228 | 229 | parent | 21.04 | 1.641 | 1.785 |
| 60 | Hydrocodone (Lortab [®] etc.) | 411 | 354 | 298 | derivative | 21.13 | 1.648 | 1.792 |
| 61 | Morphine | 268 | 397 | 269 | derivative | 21.20 | 1.654 | 1.798 |
| 62 | Codeine | 282 | 411 | 283 | derivative | 21.28 | 1.660 | 1.805 |
| 63 | Oxycodone (OxyContin [®]) | 315 | 230 | 316 | parent | 21.57 | 1.682 | 1.830 |
| 64 | Hydromorphone (Dilaudid [®]) | 397 | 341 | 398 | derivative | 21.78 | 1.699 | 1.847 |
| 65 | Flunitrazepam (Rohypnol [®] , roofies) ⁽¹¹⁾ | 312 | 285 | 286 | parent | 22.19 | 1.731 | 1.882 |
| 66 | Morphine | 380 | 382 | 509 | bis-derivative | 22.26 | 1.736 | 1.888 |
| 67 | Fentanyl (Sublimaze [®] etc.) | 245 | 146 | 189 | parent | 22.96 | 1.791 | 1.947 |

- (1) Actual retention times may vary depending on individual GC column and GC conditions. Gas chromatographic conditions used are on p. 9106-1. The mass spectrometer was operated under the conditions given on p 9106-1 (or see the Backup Data Report [4].)
- (2) GC peak numbers represent peaks as numbered in Figure 1.
- (3) Use extracted ion chromatograms of the primary ions (1') for quantifying peaks in either the scan mode or the SIM mode. Use the secondary and tertiary ions (2' and 3') for qualitative identification when necessary. These ions are selected for nearness to the primary ion to minimize false negatives from skewed spectra and from low mass interference from hydrocarbons.
- (4) Not all forms are presented. Parent compounds are not presented that have irregular or overly broad GC peak shapes under the GC conditions used. Spectra for chlorodifluoroacetyl derivatives are given in the Backup Data Report [4]
- (5) Retention time relative to 4,4'-dibromooctafluorobiphenyl.
- (6) Retention time relative to the chlorodifluoroacetyl derivative of methamphetamine.
- (7) I_S = Internal standard.
- (8) Intentional or unintentional adulterants. For example, phentermine may be added to MDMA and caffeine added to methamphetamine. Chlorpheniramine is an unintentional adulterant when pseudoephedrine containing chlorpheniramine is used as a methamphetamine precursor.
- (9) Presence of (+)-Norephedrine, N-methylpseudoephedrine and/or N-methylephedrine in pseudoephedrine or ephedrine indicates extracts of Ephedra species (spp.) as source. Presence of amphetamine and N,N-dimethylamphetamine in methamphetamine final product also indicates the same source. [22, 23, 24]
- (10) 4-Bromo-2,5-dimethoxyphenethylamine
- (11) Typical "club drugs" (piperazine analogs as ecstasy substitutes, ketamine and flunitrazepam as predatory drugs).

Table 10a. Recovery from latex-painted wall with various solvents; one gauze wipe compared with the sum of two gauze wipes^(1,2)

| Test Compound ⁽⁵⁾ | Water ⁽³⁾ | | | Isopropanol | | | Methanol | | |
|------------------------------|----------------------|------|---------------------------------|------------------|------|---------------------------------|------------------|------|---------------------------------|
| | First Gauze Wipe | | Plus Second Wipe ⁽⁴⁾ | First Gauze Wipe | | Plus Second Wipe ⁽⁴⁾ | First Gauze Wipe | | Plus Second Wipe ⁽⁴⁾ |
| | Percent | %RSD | Percent | Percent | %RSD | Percent | Percent | %RSD | Percent |
| Amphetamine | 51 | 14 | 56 | 67 | 6.0 | 78 | 90 | 4.0 | 96 |
| Cocaine | 36 | 22 | 36 | 69 | 22 | 80 | 89 | 9.1 | 94 |
| Ephedrine | 48 | 23 | 52 | 76 | 7.4 | 85 | 91 | 4.4 | 96 |
| MDMA | 40 | 20 | 44 | 61 | 9.0 | 70 | 88 | 5.3 | 94 |
| MDEA | 45 | 22 | 50 | 69 | 12 | 80 | 90 | 11 | 97 |
| Methamphetamine | 46 | 16 | 50 | 64 | 7.4 | 75 | 87 | 3.5 | 94 |
| Phencyclidine | 27 | 26 | 30 | 64 | 9.6 | 73 | 86 | 5.2 | 91 |
| Phentermine | 53 | 9.2 | 58 | 78 | 6.6 | 91 | 95 | 2.9 | 101 |
| Phenylpropanolamine | 58 | 21 | 62 | 80 | 9.3 | 95 | 85 | 5.0 | 94 |
| Pseudoephedrine | 49 | 20 | 53 | 73 | 7.0 | 85 | 95 | 3.3 | 101 |

- (1) Backup Data Report for NIOSH 9109 [13]. Area of each sample was 100 cm².
- (2) Wall was an existing standard gypsum board wall painted with a latex based paint. Painted surface was at least one year old. There were six replicates for each solvent tested.
- (3) Water was deionized water (ASTM type II). Note low recovery and high %RSD.
- (4) For the serial wipe study, each 100-cm² area was wiped again with a fresh pre-wetted gauze wipe and the amount recovered was determined separately. In practice, a second (serial) wipe is included with the first gauze wipe; both gauze wipes constitute a single sample. The percent recoveries shown in the column represent the sum of the amounts recovered in both the first and second wipes.
- (5) Each pre-measured area was spiked with 3 µg of each analyte in methanol and the methanol allowed to dry for several minutes prior to wipe sampling.

Table 10b. Recovery from various surfaces with various solvents; one gauze wipe compared with the sum of two gauze wipes⁽¹⁾

| Surface Material ⁽³⁾ | Replicates | Isopropanol | | | Methanol | | |
|---------------------------------|------------------|------------------|------|---------------------------------|------------------|------|---------------------------------|
| | | First Gauze Wipe | | Plus Second Wipe ⁽²⁾ | First Gauze Wipe | | Plus Second Wipe ⁽²⁾ |
| | | Percent | %RSD | Percent | Percent | %RSD | Percent |
| Enamel (lid of washing machine) | 4 ⁽³⁾ | 58 | 5.7 | 68 | 81 | 2.4 | 87 |
| Vinyl veneer on particle board | 4 ⁽⁴⁾ | 60 | 5.2 | 68 | 81 | 4.8 | 89 |
| Latex painted wall | 6 ⁽³⁾ | 64 | 7.4 | 75 | 87 | 3.5 | 94 |
| Refrigerator door | 2 ⁽⁴⁾ | 65 | 2.9 | 76 | 91 | 4.0 | 92 |
| Varnished hardwood panel | 2 ⁽⁵⁾ | 72 | 5.4 | 76 | 82 | 3.7 | 86 |
| Formica® countertop | 4 ⁽⁴⁾ | 75 | 4.9 | 82 | 87 | 3.8 | 91 |

- (1) Backup Data Report for NIOSH 9109 [13]. Area of each sample was 100 cm².
- (2) For the serial wipe study, each 100-cm² area was wiped again with a fresh pre-wetted gauze wipe and the amount recovered was determined separately. In practice, a second (serial) wipe is included with the first gauze wipe; both gauze wipes constitute a single sample. The percent recoveries shown in the column represent the sum of the amounts recovered in both the first and second wipes.
- (3) The Refrigerator door and the washing machine lid were from used appliances. The vinyl-veneered particle board (a book shelf), the Formica® countertop, and the varnished hardwood paneling were all purchased new. All surfaces of used and new materials were pre-cleaned with multiple rinses of methanol prior to spiking. Each pre-measured 100-cm² square was spiked with 3 µg methamphetamine.
- (4) Samples were taken using the side-to-side and then top-to-bottom wiping technique.
- (5) Half of the samples were wiped using the side-to-side wiping technique and half were wiped using the concentric squares wiping technique. There were no significant differences in recoveries. Percent recoveries and %RSDs are for both techniques combined.
- (6) Samples were taken each time using only top-to-bottom wiping with the grain of the wood in an "N" pattern.

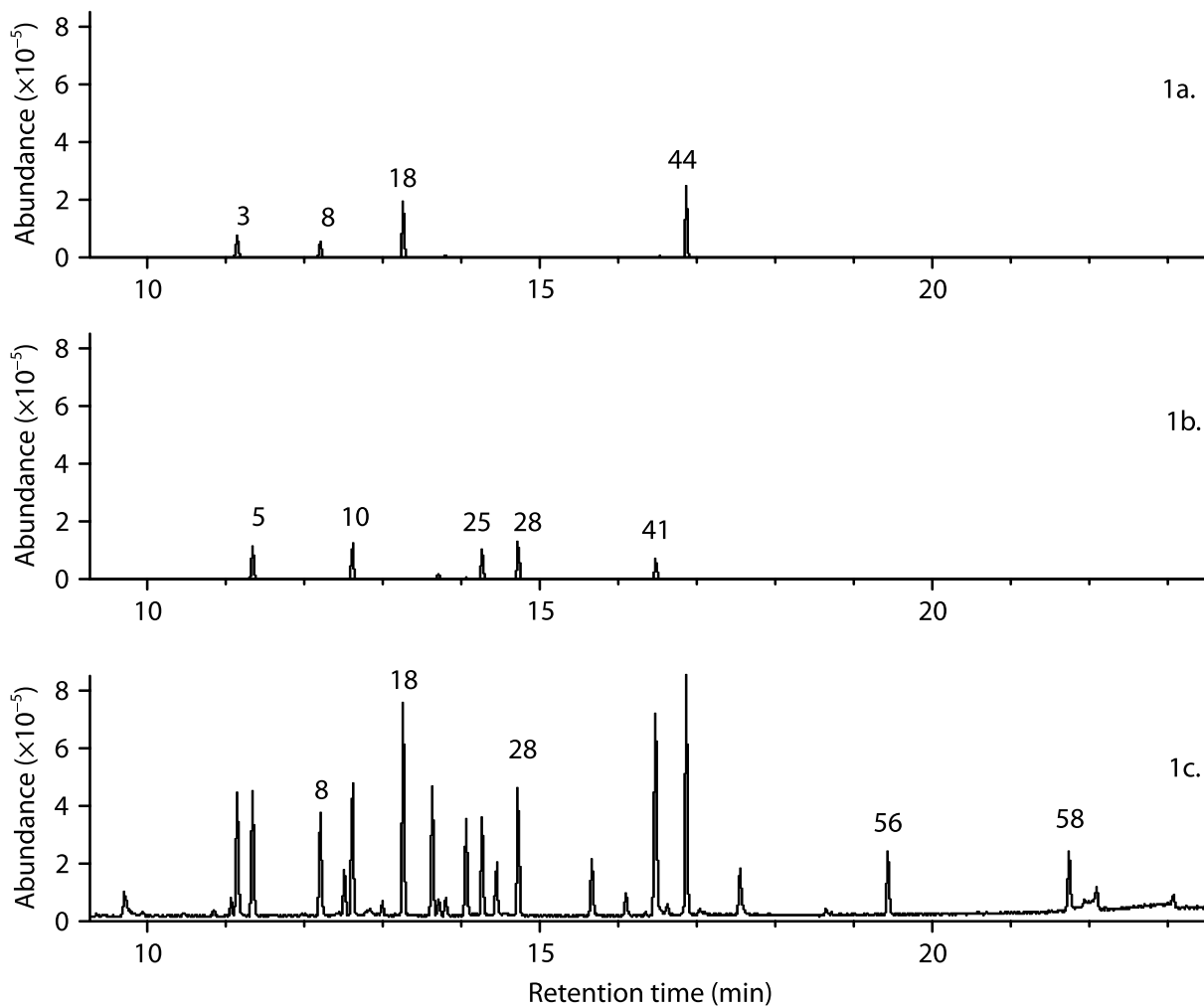

Figure 1. Typical chromatograms of chlorodifluoroacetyl derivatives by GC-MS in scan mode

Figure 1a. Extracted ion chromatogram for m/z 156 (155.70 to 156.70).

Figure 1b. Extracted ion chromatogram for m/z 170 (169.70 to 170.70).

Figure 1c. Total ion chromatogram (TIC).

GC Peak Identification: See Table 9 for identification of numbered GC peaks. (But note that retention times in Table 9 do not correspond to those in Figure 1 because a different 0.5 μ m film phenyl arylene polymer capillary column was used.)

GC-MS Conditions: See p. 9106-1 for GC-MS conditions.

APPENDIX

A. REAGENTS and SOLUTIONS:

1. For derivatization, pentafluoropropionic anhydride (PFPA) may be substituted for chlorodifluoroacetic anhydride (CDFAA). Spectra, retention times, suggested quantification ions, and precision and accuracy data for PFPA derivatives are given in the Backup Data Report [4]. Spectra for CDFAA derivatives are also given in the Backup Data Report [4].

NOTE: 100 μ L of pentafluoropropionic anhydride (PFPA) may be substituted for chlorodifluoroacetic anhydride, but the samples must be heated to 90 °C for 20-30 minutes in step 11c.

2. The instrumental internal standard, 4,4'-dibromooctafluorobiphenyl is optional. It is useful for monitoring instrument tuning and autosampler performance.
3. Primary amines form Schiff bases and enamines with ketones and aldehydes. These may in turn form derivatives with the acylating reagents. The use of acetone must be avoided strictly prior to the analytes being derivatized. Glassware and equipment rinsed with acetone must be thoroughly dried. Toluene should be avoided for making up standard solutions because it usually contains benzaldehyde, an oxidation product of toluene. Condensation products have been observed between primary amines and benzaldehyde. The only solvents recommended for the preparation of stock solutions and dilutions thereof are methanol (preferably) and isopropanol.
4. The reconstitution solvent should not contain methanol or other alcohol since the derivatized alcohol groups in ephedrine type compounds are hydrolyzed over time. Toluene containing 10 percent acetone is recommended.

B. EQUIPMENT:

1. Wipe media: Besides cotton gauze, 4"×4" (10 cm x 10 cm) 4-ply MIRASORB® (Johnson and Johnson), and 4"×4" (10 cm x 10 cm) AlphaWipe® (TX® 1004, Texwipe Corp.) were acceptable wipe media and can be used in the absence of cotton gauze. MIRASORB®, a non-woven cotton/polyester blend, is discontinued but counterparts exist that claim to be of identical construction and fiber composition. AlphaWipe® is a hydrophilic, highly adsorbent, tightly knitted continuous filament polyester wipe. Precision and accuracy data for MIRASORB® and AlphaWipe® are given in the Backup Data Report [4].
2. Shipping containers: The 50-mL polypropylene centrifuge tubes with caps are preferred for one or two gauze wipes and are not as breakable as glass 40-mL VOA vials. The 40-mL VOA vials are acceptable for single gauze wipes. Larger containers (glass with a PTFE lined cap) should be used for combining more than two gauze wipes into a single sample. The size of the container for two or more wipes should be approximately 25 mL per gauze wipe (e.g. a minimum size of 100-mL for up to four gauze wipe samples). There needs to be enough extra headspace in the shipping container to allow the desorption solution to cover the gauze wipes and to percolate freely through the wipe sample(s) during mixing.
3. Each regulatory agency having legal jurisdiction over the contaminated site may require different but specific off-site preparation and on-site sampling procedures. It is important to consult local regulatory agencies or departments of health having legal jurisdiction over contaminated sites to determine specific sampling, quality control, analyses, and reporting requirements.

C. SAMPLING:

1. Follow specific requirements of surface area to be wiped (usually 100 cm² or 1000 cm²) and action threshold (or maximum allowable residual level) set by the state or specified by the client. Uptake rates depend upon the wipe sampling method used, so the specific wipe technique used must be specified, and any deviations from the required wipe sampling requirements noted.
NOTE: To ensure that samples have not been tampered with, the use of custody seals and a chain-of-custody form is strongly recommended.
2. Prepare a rigid template from disposable cardstock or a sheet of PTFE having either a 10 cm × 10 cm or 32 cm × 32 cm square-cut hole. The template must be able to retain its shape during wiping to ensure that the areas wiped were either 100 cm² or 1000 cm². Secure the template(s) to the area(s)

to be wiped (e.g. with tape along outside edge of template). If a single-use disposable template is not used, clean the template between samples to avoid cross-contamination, and provide the laboratory with a blank wipe of the cleaned template between samples to determine that no cross-contamination has occurred.

3. A template might not always be applicable, as in curved or odd-shaped areas such as around burners on stove tops or a fan blade. In such cases sample an area as close to either 100 cm² or 1000 cm² as feasible and provide the measurement to the regulatory agency and to the analytical laboratory for proper reporting. Tape can be used to delineate the sampling area.
4. It is recommended to provide extra wipe media from the same lot for required media blanks, field equipment blanks, samples, and quality-control samples.
5. Gauze in sterile packaging is recommended to minimize the chance for cross-contamination, which can more easily occur with open bulk packaged cotton gauze.
6. To prevent contamination in the field, another alternative is to pre-wet and insert the gauze wipes into the sample containers off-site. This avoids any possibility of the bottle of methanol or isopropanol becoming contaminated on-site with methamphetamine (or other analytes). If the wipes were prepared off-site, then remove pre-wetted gauze wipe from sample container, opening only one sample container at a time. In either case, squeeze out and discard any excess solvent from the gauze wipe. Use fresh latex or nitrile gloves for each separate sample and blank. Do not use vinyl gloves due to the potential for leaching of phthalate plasticizers and contamination of the samples.
7. Wipe techniques
 - a. Concentric Squares Wiping Technique (particularly suitable for smooth and non-porous surfaces): Fold the pre-wetted gauze in half and then fold in half again. Using firm pressure wipe the area within the template. Start at one of the inside corners of the template and wipe in concentric squares, progressing toward the center. End with a scooping motion. Without allowing the gauze to touch any other surface, reverse the last fold so that the exposed side of the gauze is facing inward and using a fresh surface of the gauze, wipe the same area in the same manner as before. Roll or fold the gauze again and insert into the shipping container.

Note: Wiping in concentric squares is described by OSHA [25]. It is especially suitable for large (e.g. 1000 cm²) areas.
 - b. Side-to-side Wiping (or Blotting) Technique (particularly suitable for rough, porous, and/or soiled surfaces): Fold the pre-wetted gauze in half and then fold in half again. Using firm pressure wipe or blot the area within the template with at least five overlapping side-to-side horizontal passes (see NOTE) beginning at the top and progressing to the bottom in a "Z" pattern. End with a scooping motion. If blotting, blot at least five times on each horizontal pass (see NOTE). Without allowing the gauze to touch any other surface, reverse the last fold so that the exposed side of the gauze is facing inward. Using a fresh surface of the gauze, wipe or blot the area again with at least five overlapping top-to-bottom vertical passes beginning at the left side and progressing to the right in an "N" pattern. If blotting, blot at least five times on each vertical pass. Roll or fold the gauze again and insert into the shipping container. Blotting is suggested in areas so soiled or rough that the threads of the gauze media are continually snagged.

NOTE: On areas larger than 100 cm², more than five passes and blots will be needed.
 - c. Repeat or Serial Wiping: If isopropanol is used for wiping, a serial or repeat wipe sample of the same area with a fresh gauze wipe will improve sampling efficiency. (See recoveries for second wipe in Tables 10a and 10b.) For serial wiping, repeat the wiping procedure described above (APPENDIX steps 7a or 7b) with a fresh gauze wipe. Place the second gauze wipe into the same shipping container as the first gauze. The 50-mL polypropylene centrifuge tubes are large enough to contain up to two gauze wipes.

NOTE: If the area to be wiped remains substantially wet from the first gauze, the second gauze wipe might be used in the dry state to soak up the residual solvent from the first gauze wipe.
8. Composite sampling: Composite samples are allowed by some regulatory agencies. Their use for quantitative purposes may be subject to the permission and guidance of regulatory agencies. Refer

to guidelines of regulatory agency for directions on composite sampling. A basic default guideline for composite sampling is as follows: Do not mix inconsistent samples; that is, areas wiped must be equal in area, sampled areas must have the same high or low probability of contamination, and sampled areas must relate to a specific target appliance or site and not to several appliances or incongruous sites combined.

NOTE: Composite samples cannot meet specific action-threshold requirements for discrete sampling locations. Nor do composite samples consisting of four wipes, for example, improve the sensitivity by decreasing the LOD four fold; instead it raises the LOD by a factor related to the extra volume of desorption solution that is required to desorb a larger number of wipes. The following example illustrates these two points. Assume that the action level was $0.1 \mu\text{g}/100 \text{ cm}^2$. If the analysis gave an LOD of $0.06 \mu\text{g}/\text{sample}$ for a single wipe or discrete sample covering an area of 100 cm^2 , then the LOD for the analysis could be expressed as $0.06 \mu\text{g}/100 \text{ cm}^2$, which is low enough to be able to determine whether any discrete sample is at or exceeds the action level. Now if a composite of four wipes was taken, each with an area of 100 cm^2 for a total area wiped of 400 cm^2 , the LOD for that composite sample is not $0.06 \mu\text{g}/400 \text{ cm}^2$ nor is it $0.015 \mu\text{g}/100 \text{ cm}^2$; it is actually several times larger than $0.06 \mu\text{g}/400 \text{ cm}^2$. First of all it increases relative to the ratio of the volume of desorption solution used to desorb the sample compared to that used for the calibration standards. Secondly it has nothing to do with the area that was wiped, because the LOD for the calibration curve is determined in terms of μg per sample, independent of the area. To explain the first point, assume approximately 90 mL was used (for ease in calculation) to desorb the four wipes and 30 mL (the normal amount for a single wipe) was used to desorb each calibration standard. The calculation of the LOD for the four composited samples would be $\mu\text{g}/\text{sample} \times (\text{desorption volume for 4 wipes})/(\text{desorption volume for the calibration standards})$, or $0.06 \mu\text{g}/\text{sample} \times (90 \text{ mL}/30 \text{ mL})$, or $0.18 \mu\text{g}/\text{sample}$ for the composited sample. Since the area wiped for the composite sample was 400 cm^2 , the LOD for that sample could be expressed as $0.18 \mu\text{g}/400 \text{ cm}^2$. Regarding the second point, this value, $0.18 \mu\text{g}/400 \text{ cm}^2$, cannot be construed or mathematically reduced to $0.045 \mu\text{g}/100 \text{ cm}^2$ because it cannot be known whether three of the four wipes were blank and the fourth wipe just under the value of $0.18 \mu\text{g}$. Hence, the effective LOD per individual wipe has to be regarded not only as $0.18 \mu\text{g}/400 \text{ cm}^2$ but also as $0.18 \mu\text{g}/100 \text{ cm}^2$ because any value determined for entire 400 cm^2 might have come from just one of those 100 cm^2 areas. Thus, for composite samples, the LOD must be expressed in terms of the entire area wiped and not extrapolated to some portion thereof. In this example, an LOD of $0.18 \mu\text{g}/100 \text{ cm}^2$ is above the action threshold of $0.1 \mu\text{g}/100 \text{ cm}^2$, meaning that this composite sample cannot satisfy the requirement that residual levels be below $0.1 \mu\text{g}/100 \text{ cm}^2$. It remains for the regulatory agency and not the laboratory to determine how to apply results for composite samples to the established action levels. The same consideration that is given above for the LOD applies to results that are greater than the LOD. To avoid confusion in reporting concentrations for composite samples, it is recommended that the sample concentration (in $\mu\text{g}/\text{sample}$, whatever the sample size) and the total area wiped (in cm^2) be reported separately. For example, a result of $0.4 \mu\text{g}/\text{sample}$ for a sample consisting of four separate wipes of 100 cm^2 each (for a total area wiped of 400 cm^2), is to be reported as $0.4 \mu\text{g}/400 \text{ cm}^2$ and not averaged to $0.1 \mu\text{g}/100 \text{ cm}^2$. This manner of reporting may be required by some regulatory agencies.

9. For quality assurance purposes, regulatory agencies may require duplicate samples to be taken in the field. If such is the case, an area contiguous with and adjacent to the first area, if possible, should be wiped as described under SAMPLING. Do not re-wipe the previously wiped area. This sample is a blind sample and should not be identifiable by the analytical laboratory as a duplicate of any other sample. These are distinct from the laboratory duplicates of a single sample described in step 14 of the method. Field duplicates are useful for evaluating the consistency of sampling technique, assuming uniformity of contamination on adjacent sampling sites. Laboratory duplicates are useful for evaluating consistency of sample preparation and instrumental analysis.

D. DESORPTION FROM MEDIA:

1. An internal standard spiking solution volume of 60 μL was selected for ease in scaling from 60 μL per 30 mL to 80 μL per 40 mL of desorption solution. In either case the rate of 2 μL internal standard spiking solution per mL desorption solution was used. However, any convenient volume of internal standard spiking solution (e.g. 50 μL) that can be delivered reproducibly is acceptable. Whatever volume is chosen, there must be no variation in the volume of the internal standard spiking solution used in preparing each of the calibration standards. If spiking Strategy A is used (see APPENDIX D3), it is critical to know the exact volume of internal standard spiking solution that is applied to each sample (V_1), the media blanks (V_5), and the calibration standards (V_2), since these volumes are used for internal standard spiking solution volume corrections in step 19.
2. It is not necessary to know the exact volume of desorption solution added to each sample or the volume of residual wetting alcohol because differences in the volumes are normalized through the use of internal standards added prior to desorption.
3. Alternate strategy for spiking internal standards (spiking strategy B below): By using the exact same volume of internal standard spiking solution in all samples, blanks, QC samples, and calibration standards, regardless of the volume of desorption solution added or residual wetting alcohol, the volume corrections in step 19, (V_1/V_2 and V_5/V_2) drop out of the equation. However, the internal standard GC peak areas must still be measurable in samples where larger volumes of desorption solution are used (such as for composite samples). Because of the increased dilution of the internal standard in larger samples, this approach should be limited to desorption solution volumes of about 120 mL or less.

NOTE: There are two separate strategies for handling larger samples requiring larger volumes of desorption solvent. These are outlined below as strategies A and B.

| Number of Wipes | Size of Shipping Container (mL) | Volume of Internal Standard Spiking Solution (μL) | | Volume of Desorption Solution (mL) (Strategies A and B) |
|---------------------|---------------------------------|--|--|--|
| | | Strategy A | Strategy B | |
| 1 | 40-50 | 60 | 60 | 30 |
| 2 | 50 | 80 | 60 | 40 |
| 4 (e.g., Composite) | 100-120 | 160 | 60 | 80 |
| | | Apply volume correction factors at step 19. | Do not apply volume correction factors at step 19. | |

With either strategy, if two gauze wipes were included in the samples, then use 40 mL of desorption solution. If four gauze wipes were included in the samples, then use 80 mL of desorption solution.

- a. In strategy A, the volume of internal standard spiking solution is kept at a constant ratio of 2 μL per mL of desorption solution added. This enables larger samples to be desorbed without diminishing the area of the GC peak for the internal standard. However, a volume correction factor (V_1/V_2) is needed in the final calculations in step 19. Therefore, the exact volume of internal standard added to each of the samples relative to that added to the calibration standards must be known.
- b. In strategy B, the volume of internal standard spiking solution is kept constant for all samples and calibration standards, but need not be exactly 60 μL . This enables the final calculations to be made in step 19 without a volume correction factor. However, the area of the GC peak for the

internal standard will vary with sample desorption volume and the internal standard must be concentrated enough to be measurable where larger volumes of desorption solution are used.

E. DRYING COLUMN PREPARATION

Using 1 cm i.d. × 12-15 cm long polypropylene columns having a fritted polyethylene disc or equivalent (see EQUIPMENT), add 1 gram (~0.8 cc) of anhydrous potassium carbonate (the bed dimension will be about 1.0 cm dia. × 1 cm long). Add 1 gram (~0.8 cc) anhydrous sodium sulfate on top of the potassium carbonate. Remove any particles clinging electrostatically to the outside surfaces.

NOTE: Particles of the drying salts must not get into the collection tube, either through the frits or glass wool plugs, or from particles clinging electrostatically to the outside of the columns. Salts appear to inhibit derivatization efficiency.

F. DERIVATIZATION:

If isopropanol was used as the wetting solvent for the wipes, some of it will be co-extracted into the methylene chloride. In the presence of trace isopropanol, the crystal violet will go through a series of color changes as the extracts are evaporated to dryness. However, if methanol was used as the wetting solvent, the color of the crystal violet will remain blue to blue-violet at all stages of drying. Yet even with methanol, the same color changes can be afforded by adding 0.1 mL of isopropanol to the extracts prior to evaporation. Recoveries of analyte will not be affected in the absence of isopropanol, however, as long as the residues are dry before proceeding to step 11b.

With the presence of a small amount of added or co-extracted isopropanol, as each sample concentrates, the color of the solution will go from a blue or violet color rapidly through green to a yellow color as the residue approaches dryness, which is indicative of increasing hydrogen ion concentration in the residual alcohol. Upon continued blowing with nitrogen, the color of the residue turns back to a green or blue hue just at the point of dryness, which is indicative of the loss of excess hydrogen chloride and/or alcohol. At this stage the samples are dry and may be removed. Continued blowing beyond this point may turn the dried residue to a deep blue-violet or violet color. Losses of analyte have not been experienced even after blowing for five additional minutes beyond the violet stage as long as the hydrochloric acid had been added. Color changes will not be as dramatic or will not develop if too much crystal violet is used.

As the samples become concentrated, the tubes may be raised up in the water bath so that only the very bottoms of the tubes touch the surface of the water. This makes it easier to observe the color changes. The tubes may be raised out of the water bath, but blow-down times are lengthened.

Prolonged heating at high temperatures during derivatization with the acidic conditions of the acid anhydride derivatizing agents promotes mutual isomerization between the ephedrine diastereomers (ephedrine and pseudoephedrine). Dehydration of the ephedrine compounds (ephedrine, norephedrine, and pseudoephedrine) also occurs to some extent to yield β -amino- β -methyl styrenes. Heating during derivatization for longer than one hour is especially not recommended. Thirty minutes is sufficient.

NOTE: The color of the solution will gradually fade from purple to deep blue within about 20-30 minutes. This is due to the known tendency of phenolphthalein to fade at high pH. It has also been observed that in certain bulk samples, unknown constituents will cause the color of phenolphthalein to fade rapidly so that a purple color cannot be obtained at a pH >9, leaving only the blue color of the bromothymol blue. A quick check with pH paper can confirm that the pH is 9 or greater.

G. MEASUREMENT:

Recoveries for the laboratory control matrix spike samples (QC and QD) must meet the guidelines of the specific regulatory agency involved, if applicable (80-120% is a reasonable target in the absence of specific guidance).

NOTE: The QC samples (QC and QD) in this method may be referred to in some guidance documents as matrix spike and matrix spike duplicate samples (MS/MSD), but serve the same purpose. Analyze and report field-equipment blanks as samples. Do not subtract their values from any other sample.

Recoveries of Continuing Calibration Verification (CCV) standards must meet guidelines of regulatory agency (80-120% is a reasonable target in the absence of specific guidance). The CCV standards may be referred to in some guidance documents as "QC samples," but such "QCs" are equivalent to liquid standards (not matrix spiked samples) and serve the same purpose of the CCVs in this method.

With the GC/MS it is possible to achieve the lower limit of 0.05 µg or less per sample for methamphetamine in either the scan mode or SIM mode. The scan mode is essential where the identification of unknowns is an analytical objective. If lower limits of detection are desired or difficult to obtain in the scan mode, or for routine target compound only analyses, the instrument may be operated in the SIM mode.

H. MAKING DILUTIONS:

If the samples exceed the upper calibration range for the analysis, one of the following procedures may be used to estimate the high level concentrations.

1. Dilution Procedure A (dilution of the derivatized sample by reconstitution solvent):

This option may be used only if the analytes in the sample were completely derivatized (see NOTE below). If derivatization was complete, transfer an aliquot of the sample from the GC vial (e.g. 0.2 mL for a 1:5 dilution) to a clean GC vial and dilute with reconstitution solvent (e.g. 0.8 mL for a 1:5 dilution), cap vial, mix, and reanalyze. However, dilution also dilutes the internal standard, and this procedure is useful only if the GC peak area for the internal standard is sufficiently measurable and the calibration curve is reasonably linear. Dilutions probably should not exceed a factor of 10. If this approach is used it is not necessary to enter a dilution factor in step 19 (V_3/V_4) since both internal standard and analyte are diluted equally. The accuracy of this dilution procedure depends upon the linearity of the calibration curve in the extrapolated region beyond the upper end of the calibration curve.

NOTE: Determination of Incomplete Derivatization: Incomplete derivatization can be caused by water, glycols, a large excess of analyte, or other contaminants that interfere with or compete for the derivatization reagent. If any one of the following symptoms appears, use Dilution Procedure B described below.

- a. An "oily" film (i.e., apparently viscous liquid) or unusual residue (e.g. grit) remains after being blown-down under nitrogen after derivatization (step 11d). This may be due to the presence of water, glycols, detergents, salts, or other contaminants. Incomplete derivatization has been observed with such residues.
- b. A very large (off scale) GC peak for any one of the derivatives (e.g. pseudoephedrine, a precursor for methamphetamine) indicates the possibility of incomplete derivatization for other analytes (e.g. methamphetamine) due to competition for the derivatization reagent.
- c. A smaller than usual GC peak area for the internal standard (<50% of the average) in undiluted samples suggests that something was competing for or inhibiting the derivatizing reagent. Such inhibition or competition for the internal standard will be experienced by the target analyte as well.
- d. Incomplete derivatization can be confirmed by the obvious presence of a GC peak for an underivatized target analyte. Underivatized analytes are not always detectable. Ephedrines usually do not show up on DB-5 capillary columns in this method, but GC peaks for underivatized secondary amines (e.g. methamphetamine) and for high levels of underivatized primary amines

- (e.g. amphetamine) can be detected, usually as irregularly shaped GC peaks, depending upon GC column conditions.
- e. The problem of incomplete derivatization can be minimized by the use of an isotopic (e.g. deuterated) analog for each of the target analytes as the internal standard for that compound. This allows quantification in spite of incomplete derivatization.
2. Dilution Procedure B (dilution of a smaller aliquot of the original desorbate): If the sample was not completely derivatized or if large dilutions are needed (e.g. greater than about 1:5), the following procedure can be used. See NOTE in part 1 above. The procedure may also be used if derivatization was determined to be complete.
- a. Dilute an aliquot of the original aqueous acid desorbate of the wipe sample to 10 mL with desorption solution from a simulated sample blank, and re-extract. Add both the aliquot to be diluted and the diluting solution from the simulated blank directly to a clean 25-mL glass centrifuge tube (step 7f) and proceed to step 8. For example, to make a 1:10 dilution, transfer 1 mL of original desorbate to the 25-mL tube and dilute with 9 mL from a simulated sample blank.
 - b. The simulated sample blank should be prepared identically to the sample being diluted, using the same volumes of internal standard spiking solution and desorption solution that were used with the sample in the original desorption. For example, if the original sample was desorbed with 40 mL desorption solution with 80 μ L of added internal standard spiking solution, then prepare the simulated blank in the same way. The volume of wetting alcohol is estimated (e.g. about 3 mL per 3"×3" (7.5 cm x 7.5 cm) 12-ply cotton gauze wipe). Include a dilution factor (V_3/V_4) in the calculations in step 19 (e.g. $V_3/V_4 = 10$ mL divided by the volume in mL of original desorbate diluted to 10 mL with solution from the simulated blank). The dilution factor in the above example is 10 mL / 1 mL or 10.
 - c. Correct for differences in internal standard spiking solution volumes in step 19 (if applicable) using for V_1 the volume of internal standard spiking solution which was added to the original undiluted sample.
NOTE: This dilution procedure gives quantitative results only if the residual volume of methanol (or isopropanol) used for wetting the sample wipes was exactly the same as the volume used in preparing the calibration standards (normally about 3 mL, see Table 6). Deviations of a few milliliters in residual wetting alcohol will not affect the results for undiluted samples, but will amount to an error of a few percent in the final results of samples that are diluted.
 - d. The potential error due to differences in residual wetting solvent can be estimated for specific volumes of desorption solution and wetting alcohol. Assume the sample wipes and calibration standards are both desorbed in 30 mL of desorption solution and 3 mL of alcohol is added to the calibration standards. The potential error in volume (and final results) in the samples is approximately ± 3 % (inversely proportional) per mL difference in the residual alcohol in the samples (i.e., ± 1 mL difference in 33 mL). For 40 mL of desorption solution and 4 mL of alcohol added to the calibration standards, the error is ± 2 % for every mL difference (i.e., ± 1 mL difference in 44 mL). However, since the volume of residual wetting alcohol is not known and cannot be determined once the sample wipe has been desorbed, the actual error cannot be determined. However, the maximum possible error can be calculated. Since the maximum amount of alcohol that a recommended wipe can hold is about 6 mL when saturated (dripping wet), there can only be a deviation of plus or minus 3 mL from the 3 mL alcohol added to the calibration standards. Therefore, the maximum error in a result due to differences in the volume of residual alcohol in a cotton gauze sample compared to the standards can only be three times the error for a 1 mL difference in volume. Since the error for ± 1 mL is ± 3.03 %, the maximum error for ± 3 mL is three times larger, or ± 9.1 %. In practice, the error will be less than this because it is unlikely that the gauze samples will be completely dry or completely saturated after squeezing out the excess alcohol and wiping a surface. The practical amount of alcohol that remains in the wipes when the excess is squeezed out is between 1 and 2 mL. This translates into an error that is between +3%

and +6% in the final results for diluted samples. Undiluted samples will not be affected. This error is within the overall accuracy for the method for methamphetamine.

3. Dilution Procedure C (dilution of desorbates from dried samples):

Dilution errors for over-range samples may be corrected by knowing the exact amount of residual alcohol in the samples. The volume (or weight) of residual solvent in each gauze wipe might be determined by the difference between a wet weight and dry weight. Better yet, the error might be eliminated for diluted samples by adding, after the samples are dried (without taking any weight), the same known volume of wetting alcohol that is added to the calibration standards (i.e., 3 mL). Thereafter, if any samples need dilution, there will be no dilution errors due to differences in residual alcohol, because all samples and standards will have the same volume of alcohol and total volume of desorption solution.

However, air drying of the samples is not recommended because of the possible loss of methamphetamine due to its volatility when it is not in the salt form, which form cannot be assured in field samples. Also, manipulating the samples for weighing and drying might introduce contamination. Drying is not recommended as a procedure for analytes having a vapor pressure high enough to be lost in the process, or that tend to form azeotropes with alcohols; this is especially important when the critical action levels for remedial cleanup are at the lower end of the method calibration range. Drying is not an option if the samples have already been desorbed.



FORMULA: Table 1

MW: Table 1

CAS: Table 1

RTECS: Table 1

METHOD: 9109, Issue 1

EVALUATION: Partial

Issue 1: 17 October 2011

OSHA: none for surfaces
NIOSH: none for surfaces
Other OELs and guidelines: [1, 2, 3]

PROPERTIES: Table 2

SYNONYMS: Table 3

| SAMPLING | | MEASUREMENT | |
|--|---|--|---|
| SAMPLER: | Wipe | TECHNIQUE: | GAS CHROMATOGRAPHY/MASS SPECTROMETRY |
| SAMPLE AREA: | 100 cm ² or 1000 cm ² | ANALYTES: | Table 1 |
| SHIPMENT: | Ship refrigerated preferably, <6 °C | DESORPTION: | 0.1 M sulfuric acid |
| SAMPLE STABILITY: | At least 30 days at <6 °C (See Table 4) | CLEANUP/EXTRACTION: | Solid phase extraction |
| FIELD BLANKS: | 2 to 10 blanks per sample set | DERIVATIZATION: | MSTFA and MBHFBA |
| MEASUREMENT ACCURACY | | INJECTION VOLUME: | 2 µL Splitless |
| LEVEL STUDIED: | 3.0 µg/sample | TEMPERATURE | |
| BIAS: | Table 9 [4] | Injection: | 255 °C. |
| OVERALL PRECISION (\hat{S}_r): | Surface recovery not performed | Detector: | 285 °C |
| ACCURACY: | Table 7a and 7b [4] | Column: | 90 °C (2 min), to 310 °C (10 °C/ min), hold 6 min |
| | | MASS SPECTROMETER: | Scan mode (29 – 470 AMU), 2 scan/sec or selected ion monitoring (SIM) mode (Table 5) |
| | | CARRIER GAS: | Helium, 1.5 mL/min |
| | | COLUMN: | Capillary, fused silica, 30 m x 0.32 mm i.d., 0.5 µm U.S. Pharmacopeia (USP) G27 film |
| | | CALIBRATION: | Standards from spiked wipes with internal standard, See Table 6 |
| | | RANGE: | Table 7a and 7b [4]. |
| | | ESTIMATED LOD: | Table 4 |
| | | PRECISION (\bar{S}_r): | Table 7a and 7b [4] |

APPLICABILITY: For methamphetamine the range is 0.05 to 60 µg/sample (sample = 100 cm² or 1000 cm²). This method was developed for the analysis of selected drugs and precursors on surfaces in clandestine drug labs [5]. Sampling methodology was tested using wipes on smooth, non-porous surfaces. The APPENDIX contains sampling information for other types of surfaces.

INTERFERENCES: No chromatographic interferences detected. Water, surfactants and polyols inhibit derivatization.

OTHER WIPE METHODS: NIOSH 9106 uses liquid-liquid extraction and gas chromatography/mass spectrometry (GC/MS) to measure multiple drugs [6]. NIOSH 9111 uses liquid chromatography/mass spectrometry (LC/MS) to measure methamphet-amine [7].

REAGENTS:

NOTE: See APPENDIX A for special instructions on reagents.

1. Analytes listed in Table 1*
2. Internal standards from those listed in Table 8a
3. Solvents, residue free analytical grades
 - a. Isopropanol (IPA)*
 - b. Methanol*
 - c. Methylene chloride (CH_2Cl_2)*
 - d. Acetonitrile*
4. Concentrated sulfuric and hydrochloric acids (Analytical Reagent [AR] or trace metals analysis grades)*
5. Ammonium hydroxide (NH_4OH), 28-30%, A.C.S. grade*
6. Bromothymol blue, $\geq 95\%$, A.C.S.; crystal violet (Gentian Violet), $\geq 95\%$, A.C.S.
7. Purified gases: helium for carrier gas, nitrogen for drying
8. MSTFA (N-methyl-N-trimethylsilyl-trifluoro-acetamide) derivatizing agent*
9. MBHFBA (N-methyl-N,N-bisheptafluorobutyramide) derivatizing agent*
10. 4,4'-Dibromooctafluorobiphenyl, 99%
11. Deionized water (ASTM type II)

SOLUTIONS:

NOTE: See APPENDIX A for special instructions on solutions.

1. Prepare solutions of analytes of interest (Table 1). Calculate concentrations as the free base. Keep solutions refrigerated ($< 6^\circ\text{C}$). Protect solutions from light.
 - a. Stock solutions are prepared at about 1-2 mg/mL in methanol.
 - b. Analyte spiking solutions are prepared by diluting the stock solutions to about 200 $\mu\text{g}/\text{mL}$ each in methanol.
2. Prepare internal standard spiking solution in methanol at about 200 $\mu\text{g}/\text{mL}$.

NOTE: Add about 2 mg of crystal violet per 20 mL of internal standard spiking solution to help indicate which samples have been spiked.
3. Desorption solution: 0.1 M sulfuric acid. Add 22 mL conc. sulfuric acid to 4 liters deionized water.
4. Bromothymol blue pH indicator solution: 1 mg/mL in 4:1 isopropanol:deionized water.
5. Crystal violet indicator: 2-3 mg/mL in isopropanol.
6. Solid phase extraction (SPE) wash solution: Aqueous 0.1 M hydrochloric acid: Dilute 8.3 mL concentrated hydrochloric acid in about 800 mL water, dilute to 1 liter with ASTM Type II water.
7. SPE elution solution: 80:20:2 CH_2Cl_2 :IPA: NH_4OH v/v. Prepare fresh daily.
8. 0.3 M hydrochloric acid in methanol: Dilute 2.5 mL conc. hydrochloric acid in about 80 mL methanol; dilute to 100 mL with methanol.
9. Derivatization diluent solvent: acetonitrile containing 4 $\mu\text{g}/\text{mL}$ of 4,4'-dibromo-octafluorobiphenyl (optional).

* See SPECIAL PRECAUTIONS

EQUIPMENT:

NOTE: See APPENDIX B for special instructions on equipment.

1. Wipe, cotton gauze, (7.6 cm \times 7.6 cm) 12-ply or equivalent.
2. Sample storage and shipping container: 50-mL polypropylene centrifuge tubes with polytetrafluoroethylene (PTFE)-lined caps or equivalent.
3. Gas chromatograph/mass spectrometer detector, with column and integrator, See p. 9109-1.
4. Solid phase extraction (SPE) mixed phase cation exchange hydrophilic extraction columns (See Appendix E)
5. Collection tubes and GC vials:
 - a. Glass test tubes (13 mm x 100 mm) with PTFE-lined caps
 - b. GC autosampler vials, 2-mL Limited-volume, 300-500 μL (amber vials recommended), and caps.
6. Volumetric flasks: 10-, 100-, and 250-mL.
7. Reagent bottle, 4-L.
8. Liquid Transfer:
 - a. Syringes: 10-, 25-, and 100- μL .
 - b. Mechanical pipette with disposable tips, 5-mL.
 - c. Repeating dispensers: 1 to 5-mL.
 - d. Syringe or repeating dispenser: 100- μL .
 - e. Syringes: 250- μL .
9. Forceps.
10. Gloves: latex or nitrile. Avoid vinyl gloves (see 9109-3, Sampling, step 1, NOTE 2).
11. Rotating mixer capable of 10-30 rpm.
12. Vacuum manifold box with 12 to 36 vacuum ports, and adjustable flow rates.
13. Nitrogen blow-down apparatus with water bath capable of maintaining 35°C .
14. Vortex mixer.
15. Pasteur pipettes.
16. pH paper.
17. Template: 10 cm x 10 cm (or 1 foot x 1 foot) opening made of relatively rigid disposable cardstock or sheet of PTFE.
18. Ice or other cold media for shipping.

SPECIAL PRECAUTIONS: The solvents are flammable and have associated adverse health effects. Phenethylamines target the nervous system at very low concentrations and are easily absorbed through the skin. Avoid breathing vapors. Avoid skin contact. Work should be performed in a hood with adequate ventilation. Analysts must wear proper eye and hand protection (e.g., latex gloves) to prevent absorption of even small amounts of amines through the skin as well as for protection from the solvents and other reagents. Dissolving concentrated hydrochloric or sulfuric acid in water is highly exothermic. Goggles must be worn. The derivatization reagents react violently with water.

Caution must also be exercised in the handling and analysis of samples. Clandestine drug labs may produce unknown and seriously toxic by-products. For example, in the manufacture of designer drugs (e.g., MPPP, a homolog of Alphaprodine), at least one very neurotoxic by-product, 1-methyl-4-phenyl-1,2,5,6-tetrahydropyridine (MPTP), has been identified that specifically and irreversibly causes Parkinson's disease [8,9].

SAMPLING:

See APPENDIX C for special instructions on sampling.

1. Using a new pair of gloves, remove a gauze wipe from its protective package. Moisten the wipe with approximately 3 to 4 mL of methanol (or isopropanol).

NOTE 1: Apply no more solvent than that needed to moisten approximately the central 80% of the area of the gauze wipe. Excess solvent may cause sample loss due to dripping from the wipe.

NOTE 2: Do not use vinyl gloves due to the potential for leaching of phthalate plasticizers and contamination of the samples.

2. Place the template over the area to be sampled (may tape in place along outside edge of template). Wipe the surface to be sampled with firm pressure, using vertical S-strokes. Fold the exposed side of the pad in and wipe the area with horizontal S-strokes. Fold the pad once more and wipe the area again with vertical S-strokes.

3. Fold the pad, exposed side in, and place in shipping container and seal with cap.

NOTE: Keep samples refrigerated (<6 °C). While methamphetamine and several related amines are stable on the recommended wipe media for at least 7 days at room temperature, refrigeration is recommended as soon as possible (see Table 4).

4. Either clean the template before use for the next sample or use a new disposable template.
5. Label each sample clearly with a unique sample identifier.
6. Prepare a minimum of two field blanks with one field blank for every ten samples.

NOTE: In addition, include at least 3 media blanks for the analytical laboratory to use for their purposes. The wipes used for the media blanks should be from the same lot as the field samples.

SAMPLE PREPARATION:

See APPENDIX D for special instructions on sample preparation.

7. Desorption from media:

- a. Remove cap from shipping container.

NOTE: Sample wipe should fit loosely in the container. If not, transfer sample to a larger container.

- b. Spike 60 µL of internal standard spiking solution onto each wipe sample.

- c. Add 30 mL desorption solution (0.1 M sulfuric acid).

NOTE: If the samples were transferred to a larger container, rinse the original shipping container with the desorption solution, shake, and decant the rinsate into the larger container. Cap securely and mix contents by inverting the tubes end over end on a rotary mixer or equivalent at 10-30 rpm for at least one hour.

- d. Check the pH which should be about ≤ 4 . If needed, adjust the pH with diluted (2.5 to 3 M) sulfuric acid drop-wise, mixing the contents by shaking or inversion a few times after each addition of acid before checking the pH.
 - e. After mixing, transfer 10 mL of supernatant to a 25-mL glass centrifuge tube.
NOTE: If extraction is to be performed on a subsequent day, store samples in a refrigerator. Analytes are stable in the desorption solution for at least one week refrigerated.
8. Solid phase extraction procedure:
- a. Column selection: Select one of the SPE columns listed in Appendix E. Each brand of column has a slightly different conditioning procedure and resistance to flow. Other brands of SPE columns may also work. Elution profiles of drugs to be analyzed need to be determined before use of columns other than those specified.
 - b. Setting up columns: Attach SPE columns to vacuum ports on the manifold. Attach vacuum line to vacuum pump capable of 25-30 psi vacuum.
 - c. Conditioning: Condition each column with 1 column volume (3 mL) of methanol followed by 1 column volume of Type II deionized water. For some brands the conditioning volume is 1/3 column volume. Check product literature.
 - d. Loading: Load each SPE column with 5 mL of the sample acid desorbate solution. Adjust vacuum so that the flow rate is about 1-2 mL/minute. The vacuum required to obtain that flow rate varies with brand of SPE column.
 - e. First wash: Wash each column with 1 column volume (3 mL) of 0.1 M aqueous hydrochloric acid. For some brands this volume may be decreased to 1 or 2 mL. Check product literature.
 - f. Second wash: Wash each column with 1 column volume of methanol. Add the methanol in 2 or 3 separate aliquots to ensure that the aqueous acid is flushed through. Discard all effluents.
 - g. Drying: Remove last traces of water in the SPE columns by pulling air through the columns under increased vacuum (e.g., 25 psi) for 5 minutes. Silica-based SPE columns or columns with high resistance to flow may require a longer time to reach dryness.
 - h. Elution: Position 13 x 100 mm collection tubes under each column. Elute analytes with 3 mL of elution solution (80:20:2 methylene chloride:isopropanol:concentrated ammonium hydroxide v/v, freshly prepared). Adjust vacuum so that the flow rate is 1 mL/minute or less. For some brands this flow rate may occur without applied vacuum. Most of the analytes (e.g., amphetamine, ephedrine, methamphetamine, etc.) are eluted in the first milliliter.
9. Evaporation: To each collection tube containing eluate, add about 5 μ L crystal violet solution and 100 μ L of 0.3 M hydrochloric acid in methanol. The samples are evaporated to dryness under gently blowing nitrogen at 25-35 °C. The samples should be removed from the evaporation bath within a few minutes after dryness. A mixed whitish and purple residue will remain. The purple color of the crystal violet helps to make the residue more visible when dried. The color of the crystal violet remains a constant blue to blue-violet during concentration and drying.
10. Derivatization: (Perform under the hood.) Add 100 μ L of acetonitrile containing the optional dibromooctafluorobiphenyl secondary internal standard. Add 25 μ L MSTFA and 25 μ L MBHFBA in that order. Cap tubes between additions to prevent atmospheric humidity from affecting the reagents. (See note below. Have no more than 5 or 6 tubes uncapped at a time.) Vortex each tube about 4-5 seconds. Using Pasteur pipettes, transfer each mixture to low-volume (300-500 μ L) amber autosampler vials and cap vials.
- NOTE 1: Some derivatization takes place at room temperature, especially trimethylsilylation. Derivatization is completed on-column after injection. No prior heating is required or recommended.
- NOTE 2: The color of the reconstituted solution should be deep blue to violet. If the color turns light blue or turquoise upon standing, moisture may be present (the vials may not have been capped tightly enough). Such samples need to be reprocessed beginning at step 8 since the derivatives are not stable in the presence of moisture. If the vials are securely capped, the

solutions will be stable for several days at room temperature and at least a week refrigerated. Protect vials from light (amber vials recommended.)

11. Analyze samples, standards, blanks, and QCs by GC-MS. (See MEASUREMENT, steps 15-17 and p. 9109-1.)

CALIBRATION AND QUALITY CONTROL:

12. Determine retention times for the derivatives of the analytes of interest using the column and chromatographic conditions specified on page 9109-1. Table 10 gives typical retention times for various drugs, precursors, and adulterants. Figure 1 shows a typical chromatogram.
13. Calibrate daily with at least six calibration standards and a blank selected from Table 6 to cover the analytical range.
 - a. Prepare the analyte spiking solution as follows: Add known amounts of individual drug stock solutions to a volumetric flask and dilute to volume with methanol. A recommended final concentration for this solution is approximately 200 µg each per mL.
 - b. Prepare calibration standards and media blanks in clean shipping containers (e.g., 50-mL polypropylene centrifuge tubes or equivalent).
NOTE: Liquid standards (standards without added blank wipe media) may be prepared in lieu of media standards if cotton gauze was used for the samples.
 - c. Add 3 mL methanol (or isopropanol if isopropanol was used with the samples in the field) to each calibration standard and media blank.
NOTE: If two gauze wipes were routinely used for every sample, increase methanol (or isopropanol) to 4 mL. See Table 6, footnote 2.
 - d. Spike a known volume of analyte spiking solution into each calibration standard by spiking directly onto the media or into solution. Use the spiking volumes suggested in Table 6 to cover the desired range.
 - e. Process each of these through the desorption, solid phase extraction (SPE), drying, and derivatization steps (steps 7 through 11) along with the field samples.
 - f. Analyze these along with the field samples. (See MEASUREMENT, steps 15-17.)
14. Prepare matrix-spiked and matrix-spiked duplicate (QC and QD) quality control samples [10].
 - a. Cotton gauze from the same lot used for taking samples in the field should be provided to the analytical laboratory to prepare these matrix-spiked quality control samples.
 - b. The quality control samples (QC and QD) must be prepared independently at concentrations within the analytical range. (See Table 6 for applicable concentration ranges.)
 - c. One quality control media blank (QB) must be included with each QC and QD pair.
 - d. Spike QC and QD with a known amount of target analyte as suggested in Table 6.
 - i. Transfer clean wipes to new shipping containers.
 - ii. Add 3 mL of methanol (or isopropanol if isopropanol was used in wiping) to each wipe.
 - iii. Spike QC and QD with a known amount of analyte as suggested in Table 6.
NOTE: If two gauze wipes were used for the majority of samples in an analytical set, use two clean gauze wipes for each QB, QC, and QD, and increase isopropanol (or methanol) to 4 mL. See Table 6, footnote 2.
 - e. Process quality control samples through the desorption, SPE, drying, and derivatization steps (steps 7 through 11) along with the calibration standards, blanks, and field samples.
 - f. Analyze these along with the calibration standards, blanks, and field samples. (See MEASUREMENT, steps 15-17.)

MEASUREMENT:

See APPENDIX G for special instructions on measurement.

15. Analyze the calibration standards, quality control samples, blanks, a continuing calibration verification (CCV) standard consisting of one of the initial calibration standards, and samples by GC/MS.

Set gas chromatograph according to manufacturer's recommendations and to conditions listed on page 9109-1.

a. Set mass spectrometer conditions to manufacturer's specifications and those given on page 9109-1 for the scan mode or those in Table 5 for the SIM mode.

b. Inject sample volume with autosampler or manually.

NOTE: After the derivatives are prepared and just before analyzing any samples or standards, inject the highest concentrated standard several times in order to prime or deactivate the GC column and injection port. This will help minimize any drift in the instrument's response to target analytes relative to their internal standards.

c. After analysis, the vials should be recapped promptly and refrigerated if further analysis is anticipated.

16. Using extracted ion current profiles for the primary (quantification) ions specific to each analyte, measure GC peak areas of analyte(s) and internal standard(s) and compute relative peak areas by dividing the peak area of the analyte by the area of the appropriate internal standard. Recommended primary (quantification) ions and internal standards are given in Tables 5, 7 and 8. Prepare calibration graph (relative peak area vs. μg analyte per sample).

17. Samples from initial investigations of clandestine laboratories are likely to include highly contaminated samples. If sample results exceed the upper range of the calibration curve, the sample in the GC vial may be diluted and reanalyzed or a smaller aliquot of the initial acid desorbate diluted, re-extracted, derivatized, and analyzed. Refer to APPENDIX H for instructions and limitations on making dilutions.

CALCULATIONS:

18. Determine the mass in μg /sample of respective analyte found in the wipe samples, and in the media blank from the calibration graph.

19. Calculate final concentration, C , of analyte in μg /sample:

$$C = c \frac{V_1 V_3}{V_2 V_4} - b \frac{V_5}{V_2}$$

c = concentration in sample (in μg /sample determined from the calibration curve).

$\frac{V_1}{V_2}$ = volume correction factor (needed only when the volume of internal standard spiking solution used for spiking the samples - such as for composite samples requiring larger desorption solution volumes - is different from that used for spiking the calibration standards). (See Table 6, footnote 4).

V_1 = volume in μL of internal standard spiking solution used to spike samples.

V_2 = volume in μL of internal standard spiking solution used to spike the standards.

$\frac{V_3}{V_4}$ = dilution factor, if applicable.

V_3 = 5 mL (volume of desorbate normally taken for extraction in step 8d).

V_4 = volume in mL of desorbate actually taken for extraction and diluted to 5 mL with blank desorbing solution containing internal standard.

b = concentration in media blank (in μg /sample determined from the calibration curve).

$\frac{V_5}{V_2}$ = volume correction factor for the media blank (needed only if the volume of internal standard spiking solution used for spiking the media blank is different from that used for spiking the calibration standards).

V_5 = volume in μL of internal standard spiking solution used to spike media blank.

20. Report concentration, C' , in μg per total area wiped (in cm^2) as follows:

$$C' = \frac{C}{A}$$

C = $\mu\text{g}/\text{sample}$ (step 19).

A = Total area wiped in cm^2 per sample.

NOTE: In general, if the area wiped was greater than or less than 100 cm^2 , do not convert value to $\mu\text{g}/100 \text{ cm}^2$ unless specifically required or allowed by agency having legal jurisdiction. For example, if the sample was a composite sample and the area was 400 cm^2 , report results as $\mu\text{g}/400 \text{ cm}^2$ and not averaged to $\mu\text{g}/100 \text{ cm}^2$ since regulatory agencies might not allow averaging of composite results to 100 cm^2 . To avoid confusion, report separately both $\mu\text{g}/\text{sample}$ (C) and the total area wiped in cm^2 per sample (A) for both discrete and composite samples.

EVALUATION OF METHOD:

This method was developed according to the NIOSH sampling and analytical method development guidelines [11]. This method was evaluated for those analytes listed in Tables 7a and 7b over a range of approximately $0.1 \mu\text{g}/\text{sample}$ to $30 \mu\text{g}/\text{sample}$ for several types of sampling media. These concentration levels represent approximately the 1 through 300 times the limit of quantitation (LOQ) level for most of the analytes. Results are reported in the Backup Data Report [4].

The limits of detection (LOD and LOQ) were determined by preparing a series of liquid standards in desorption solution, processing by the SPE of NIOSH 9109, and analyzing in the scan mode. The LODs were estimated using the procedure of Burkart [12]. An LOD of $0.1 \mu\text{g}/\text{sample}$ for methamphetamine on wipes was achieved in the scan mode. The LOD was set at $0.1 \mu\text{g}/\text{sample}$ because that was the level of the lowest calibration standard in the LOD/LOQ study. Lower LODs (e.g., $0.02 \mu\text{g}/\text{sample}$) have been achieved in practice by including calibration standards at lower concentration levels. The cleanliness and performance of the mass spectrometer must be maintained such that at $0.1 \mu\text{g}/\text{sample}$ a signal of at least 5 to 10 times the baseline noise is achievable. This is more easily accomplished in the SIM mode.

Six different wipe media were evaluated. These were $3'' \times 3''$ ($7.5 \text{ cm} \times 7.5 \text{ cm}$) 12-ply cotton gauze, $4'' \times 4''$ ($10 \text{ cm} \times 10 \text{ cm}$) AlphaWipe® (TX 1004), $4'' \times 4''$ ($10 \text{ cm} \times 10 \text{ cm}$) 4-ply NU GAUZE®, $4'' \times 4''$ ($10 \text{ cm} \times 10 \text{ cm}$) 4-ply MIRASORB®, $4'' \times 4''$ ($10 \text{ cm} \times 10 \text{ cm}$) 6-ply SOF-WICK®, and $4'' \times 4''$ ($10 \text{ cm} \times 10 \text{ cm}$) 4-ply TOPPER® sponges. Results are given in the Backup Data Report [4]. No synthetic media performed better than cotton gauze. Some media (NU GAUZE® and SOF-WICK®) gave inconsistent results.

Precision and accuracy were determined by analyzing 6 replicates at each of 6 concentration levels (nominally $0.1, 0.3, 1, 3, 10,$ and $30 \mu\text{g}/\text{sample}$). Results are presented in Table 7a for cotton gauze and 7b for AlphaWipe®. The best precision and accuracies were dependent upon the use of carefully chosen internal standards, especially with steric hindrance of the amine (e.g., having N-ethyl and N-propyl groups). Long term sample storage stability was determined for periods up to 30 days under refrigeration ($<6^\circ\text{C}$) and for up to 7 days at room temperature ($22\text{-}24^\circ\text{C}$). Results are given in Table 4.

Chlorodifluoroacetic anhydride (CDFAA) and pentafluoro propionic anhydride (PFPA) were evaluated as derivatizing agents for the SPE eluates. These were not effective, probably due to the high level of ammonium chloride residues in the SPE column eluates. They were most effective with the liquid-liquid extraction procedure of NIOSH 9106 [6].

For SPE, the mixed silanization-acylation reagent, MSTFA and MBHFBA [13-15], proved very effective. The derivatization mixture is transferred directly to amber mini-GC vials and direct-injected without prior heating.

Recovery of amphetamines from six different types of surfaces using cotton gauze was evaluated (see Table 9a and 9b). The practice of serial wiping (wiping the same surface area a second time with a second gauze wipe and combining both wipes as a single sample) was evaluated. Four solvents for wetting the gauze were tested (distilled water, 5% distilled white vinegar, isopropanol, and methanol). Six replicates samples were taken on a latex painted wall. Recoveries and precisions are given in Table 9a and 9b. The recoveries with 5% distilled white vinegar were better than for distilled water, but not as good as for isopropanol. Methanol is superior to isopropanol. Recoveries with isopropanol are greatly improved with a repeat (serial) wipe (11% improvement compared to only about 6% improvement with methanol). The study and results are reported in the Backup Data Report for NIOSH 9109 [4]. Additional research on surface sample recovery and solvent effectiveness has been reported by Van Dyke et al [13] and Serrano et al. [16].

REFERENCES:

- [1] ACGIH [2013]. TLVs and BEIs based on the documentation of the Threshold Limit Values for chemical substances and physical agents and Biological Exposure Indices. Cincinnati, Ohio: American Conference of Governmental Industrial Hygienists. [www.acgih.org]. Data accessed April 2014.
- [2] Institut für Arbeitsschutz der Deutschen Gesetzlichen Unfallversicherung [2013]. GESTIS database on hazardous substances (German Social Accident Insurance). Sankt Augustin, FRG: [http://www.dguv.de/ifa/GESTIS]. Data accessed April 2014.
- [3] EPA [2013]. Voluntary guidelines for methamphetamine laboratory cleanup. [https://www.epa.gov/sites/production/files/documents/meth_lab_guidelines.pdf]. Date accessed March 2016.
- [4] Reynolds JM, Siso MC, Perkins JB [2004]. Backup Data Report for NIOSH 9109, Methamphetamine and illicit drugs, precursors, and adulterants on wipes by solid phase extraction, Abridged. Unpublished. Prepared under NIOSH Contract 200-2001-0800.
- [5] Martyny JW, Arbuckle SL, McCammon CS Jr., Esswein EJ, Erb N [2003]. Chemical exposures associated with clandestine methamphetamine laboratories [https://www.nationaljewish.org/NJH/media/pdf/pdf-EnvOccChemical_Exposures.pdf]. Date accessed April 2014.
- [6] NIOSH [2011]. Methamphetamine and illicit drugs, precursors, and adulterants on wipes by liquid-liquid extraction: Method 9106. In: Ashley KA, O'Connor PF, eds. NIOSH manual of analytical methods. 5th ed. Cincinnati, OH: U.S. Department of Health and Human Services, Centers for Disease Control and Prevention, National Institute for Occupational Safety and Health, [www.cdc.gov/niosh/nmam/].
- [7] NIOSH [2011]. Methamphetamine on wipes by liquid chromatography/mass spectrometry: Method 9111. In: Ashley KA, O'Connor PF, eds. NIOSH manual of analytical methods. 5th ed. Cincinnati, OH: U.S. Department of Health and Human Services, Centers for Disease Control and Prevention, National Institute for Occupational Safety and Health, [www.cdc.gov/niosh/nmam/].
- [8] Baum RM [1985]. New variety of street drugs poses growing problem. *Chemical and Engineering News*, 63(63):7-16.
- [9] Buchanan JF, Brown CR [1988]. Designer drugs, a problem in clinical toxicology. *Medical Toxicology* 3:1-17.
- [10] NIOSH [1994]. Chapter C: Quality Assurance. In: Eller PM, Cassinelli ME, eds. NIOSH manual of analytical methods, 4th ed. Cincinnati, OH: Department of Health and Human Services, Centers for Disease Control and Prevention, National Institute for Occupational Safety and Health, DHHS (NIOSH) Publication No. 94-113. [www.cdc.gov/niosh/nmam/].
- [11] NIOSH [1995]. NIOSH Technical Report: Guidelines for air sampling and analytical method development and evaluation. By Kennedy ER, Fischbach TJ, Song R, Eller PM, Shulman SA. Cincinnati, OH: U.S. Department of Health and Human Services, Public Health Service, Centers for Disease Control and Prevention, National Institute for Occupational Safety and Health, DHHS (NIOSH) Publication No. 95-117.
- [12] Burkart JA [1986]. General procedures for limit of detection calculations in the industrial hygiene chemistry laboratory. *Applied Industrial Hygiene* 1(3):153-155.

- [13] Van Dyke MV, Serrano KA, Kofford S, Contreras J, Martyny JW [2011]. Variability and specificity associated with environmental methamphetamine sampling and analysis. *J Occup Environ Hyg* 8(11):636-4. Date accessed May, 2011.
- [14] Little JL [1999]. Artifacts in trimethylsilyl derivatization reactions and ways to avoid them. *Journal of Chromatography. A*, 844:1-22.
- [15] Crockett DK, Frank EL, and Roberts WL [2002]. Rapid analysis of metanephrine and normetanephrine in urine by gas chromatography-mass spectrometry. *Clinical Chemistry* 48: 332-337.
- [16] Serrano KA, Martyny JW, Kofford S, Contreras JR, Van Dyke MV [2012]. Decontamination of clothing and building materials associated with the clandestine production of methamphetamine. *J Occup Environ Hyg* 9(3):185-197.
- [17] Budavari S, ed. [1989]. *Merck Index*, 11th ed. Rahway, New Jersey: Merck and Co.
- [18] Sweet DV, ed. [1997]. *Registry of toxic effects of chemical substances*. DHHS (NIOSH) Publication No. 97-119. [<https://www.cdc.gov/niosh/>].
- [19] Sigma-Aldrich MSDS sheets [<http://www.sigma-aldrich.com>]. Date accessed: May 10, 2004.
- [20] Cerilliant Analytical Reference Materials. 811 Paloma Drive, Suite A, Round Rock, Texas 78664 [www.cerilliant.com].
- [21] Howard PH, Meylan WM [1997]. *Handbook of physical properties of organic chemicals*. Boca Raton, Florida: CRC/Lewis Publishers. See also Syracuse Research Corporation's website [<http://www.srcinc.com>] for demos and updates. Date accessed May 10, 2004.
- [22] Zhang JS, Tian Z, Lou ZC [1989]. Quality evaluation of twelve species of chinese ephedra (Ma Huang). *Acta Pharmaceutica Sinica* 24(11):865-871.
- [23] Cui JF, Zhou TH, Zhang JS, and Lou ZC [1991]. Analysis of alkaloids in chinese ephedra species by gas chromatographic methods. *Phytochemical Analysis* 2:116-119.
- [24] Andrews KM [1995]. Ephedra's role as a precursor in the clandestine manufacture of methamphetamine. *Journal of Forensic Sciences* 40(4):551-560.
- [25] OSHA [2001]. Evaluation guidelines for surface sampling methods. Industrial Hygiene Chemistry Division, OSHA Salt Lake Technical Center, Salt Lake City, Utah. [<http://www.osha.gov/dts/sltc/methods/surfacesampling/surfacesampling.pdf>]. Date accessed May 2011.

METHOD DEVELOPMENT BY:

John M. Reynolds, Maria Carolina Siso, and James B. Perkins, DataChem Laboratories, Inc., Salt Lake City, Utah under NIOSH Contract CDC 200-2001-0800.

Disclaimer: Mention of any company or product does not constitute endorsement by NIOSH. In addition, citations to websites external to NIOSH do not constitute NIOSH endorsement of the sponsoring organizations or their programs or products. Furthermore, NIOSH is not responsible for the content of these websites. All web addresses referenced in this document were accessible as of the publication date.

Table 1. Formula and registry numbers of analytes

| Compound (alphabetically) | MW ⁽¹⁾ (Daltons) | | | Structural Formula As free base | CAS # ⁽²⁾ | RTECS ⁽⁶⁾ |
|--------------------------------------|-----------------------------|----------|---------------------|---|--|-------------------------------------|
| | Free base | HCl salt | Hemisulfate salt | | | |
| (DL)-Amphetamine | 135.21 | 171.67 | 184.25 | $C_6H_5 \cdot CH_2 \cdot CH(CH_3) \cdot NH_2$ | 300-62-9 ⁽³⁾ 60-13-9 ⁽⁵⁾ | SH9450000 SI1750000 |
| (D)-Amphetamine ⁽⁷⁾ | 135.21 | 171.67 | 184.25 | $C_6H_5 \cdot CH_2 \cdot CH(CH_3) \cdot NH_2$ | 51-64-9 ⁽³⁾ 51-63-8 ⁽⁵⁾ | SI1400000 |
| (L)-Amphetamine | 135.21 | 171.67 | 184.25 | $C_6H_5 \cdot CH_2 \cdot CH(CH_3) \cdot NH_2$ | 156-34-3 ⁽³⁾ | SH9050000 |
| Caffeine | 194.19 | | | $(CH_3)_3 \cdot [C_5HN_4O_2]$ | 58-08-2 ⁽³⁾ | EV6475000 |
| (DL)-Ephedrine | 165.24 | 201.70 | 214.28 | $C_6H_5 \cdot CH(OH) \cdot CH(CH_3) \cdot NH \cdot CH_3$ | 90-81-3 ⁽³⁾ 134-71-4 ⁽⁴⁾ | |
| (L)-Ephedrine ⁽⁸⁾ | 165.24 | 201.70 | 214.28 | $C_6H_5 \cdot CH(OH) \cdot CH(CH_3) \cdot NH \cdot CH_3$ | 299-42-3 ⁽³⁾ 50-98-6 ⁽⁴⁾ 134-72-5 ⁽⁵⁾ | KB0700000 KB1750000 KB2625000 |
| (D)-Ephedrine | 165.24 | 201.70 | 214.28 | $C_6H_5 \cdot CH(OH) \cdot CH(CH_3) \cdot NH \cdot CH_3$ | 321-98-2 ⁽³⁾ 24221-86-1 ⁽⁴⁾ | KB0600000 KB1925000 |
| (±)-MDEA | 207.27 | 243.73 | | $CH_2O_2C_6H_3 \cdot CH_2 \cdot CH(CH_3) \cdot NH \cdot C_2H_5$ | 82801-81-8 ⁽³⁾ 116261-63-2 ⁽⁴⁾ | |
| (±)-MDMA | 193.24 | 229.71 | | $CH_2O_2C_6H_3 \cdot CH_2 \cdot CH(CH_3) \cdot NH \cdot CH_3$ | 42542-10-9 ⁽³⁾ 92279-84-0 ⁽⁴⁾ | SH5700000 |
| (+)-MDMA ⁽⁷⁾ | 193.24 | 229.71 | | $CH_2O_2C_6H_3 \cdot CH_2 \cdot CH(CH_3) \cdot NH \cdot CH_3$ | 64057-70-1 ⁽⁴⁾ | SH5700000 |
| (DL)-Methamphetamine | 149.24 | 185.70 | 198.28 | $C_6H_5 \cdot CH_2 \cdot CH(CH_3) \cdot NH \cdot CH_3$ | 4846-07-5 ⁽³⁾ | |
| (D)-Methamphetamine ⁽⁷⁾ | 149.24 | 185.70 | 198.28 | $C_6H_5 \cdot CH_2 \cdot CH(CH_3) \cdot NH \cdot CH_3$ | 537-46-2 ⁽³⁾ 51-57-0 ⁽⁴⁾ | SH4910000 SH5455000 |
| (L)-Methamphetamine | 149.24 | 185.70 | 198.28 | $C_6H_5 \cdot CH_2 \cdot CH(CH_3) \cdot NH \cdot CH_3$ | 33817-09-3 ⁽³⁾ | SH4905000 |
| Phencyclidine | 243.39 | 279.85 | | $C_6H_5 \cdot C[C_5H_{10}] \cdot N[C_5H_{10}]$ | 77-10-1 ⁽³⁾ 956-90-1 ⁽⁴⁾ | TN2272600 TN2272600 |
| Phentermine | 149.24 | 185.70 | | $C_6H_5 \cdot CH_2 \cdot C(CH_3)_2 \cdot NH_2$ | 122-09-8 ⁽³⁾ 1197-21-3 ⁽⁴⁾ | SH4950000 |
| (DL)-Norephedrine | 151.21 | 187.67 | 200.25 | $C_6H_5 \cdot CH(OH) \cdot CH(CH_3) \cdot NH_2$ | 14838-15-4 ⁽³⁾ 154-41-6 ⁽⁴⁾ | RC2625000 DN4200000 |
| 1R,2S (-)-Norephedrine | 151.21 | 187.67 | 200.25 | $C_6H_5 \cdot CH(OH) \cdot CH(CH_3) \cdot NH_2$ | 492-41-1 ⁽³⁾ | RC2275000 |
| 1S,2R (+)-Norephedrine | 151.21 | 187.67 | 200.25 | $C_6H_5 \cdot CH(OH) \cdot CH(CH_3) \cdot NH_2$ | 37577-28-9 ⁽³⁾ | |
| 1S,2S (+)-Norephedrine | 151.21 | 187.67 | 200.25 | $C_6H_5 \cdot CH(OH) \cdot CH(CH_3) \cdot NH_2$ | 36393-56-3 2153-98-2 ⁽⁴⁾ 492-39-7 ⁽⁴⁾ | RC9275000 |
| (D)-Pseudoephedrine ^(8,9) | 165.24 | 201.70 | 214.28 | $C_6H_5 \cdot CH(OH) \cdot CH(CH_3) \cdot NHCH_3$ | 90-82-4 ⁽³⁾ 345-78-8 ⁽⁴⁾ | UL5800000 UL5950000 |
| (L)-Pseudoephedrine ⁽¹⁰⁾ | 165.24 | 201.70 | 214.28 | $C_6H_5 \cdot CH(OH) \cdot CH(CH_3) \cdot NH \cdot CH_3$ | 321-97-1 ⁽³⁾ | |

- (1) Molecular weights are calculated from the empirical formula using the 1987 IUPAC Atomic Weights of the Elements, Merck Index [17]. The molecular weight of the hemisulfate is ½ the weight of the 2:1 sulfate salt (2 moles amine + 1 mole H₂SO₄).
- (2) CAS from various sources: Merck Index [17], NIOSH RTECS [18], MSDS sheets from Sigma/Aldrich [19], Cerilliant [20], and other sources [21].
- (3) Free base form.
- (4) Hydrochloride salt.
- (5) 2:1 Sulfate salt (2 moles amine + 1 mole H₂SO₄).
- (6) RTECS = NIOSH Registry of Toxic Effects of Chemical Substances [18].
- (7) More active isomer.
- (8) Naturally occurring isomer.
- (9) The D form of pseudoephedrine is a decongestant.
- (10) The L form of pseudoephedrine is a bronchodilator. Dehydroxylation forms the less active L-methamphetamine.

Table 2. Physical properties of analytes⁽¹⁾

| Compound (alphabetically) | CAS | m.p. (°C) | Vapor Pressure (mm Hg) | pK _a ⁽⁴⁾ | Log P ⁽⁵⁾ | Solubility in Water, g/100mL |
|-----------------------------|------------|------------------------|------------------------------|---|----------------------|---------------------------------|
| (DL)-Amphetamine | 300-62-9 | — | — | 10.1 @ 20 °C | 1.76 | 2.8 @ 25 °C |
| (D)-Amphetamine | 51-64-9 | <25 | — | 9.9 ⁽⁶⁾ | 1.76 | — |
| (D)-Amphetamine sulfate | 51-63-8 | >300 | — | — | 6.81 | — |
| (L)-Amphetamine | 156-34-3 | — | 0.201 @ 25 °C | 10.1 @ 20 °C | 1.76 | 2.8 @ 25 °C |
| Caffeine | 58-08-2 | 238 | 15 @ 89 °C | 10.4 @ 40 °C | -0.07 | 2.16 @ 25 °C |
| (DL)-Ephedrine | 90-81-3 | 76.5 | — | — | 0.68 | — |
| (L)-Ephedrine | 299-42-3 | 34 | 0.00083 @ 25 °C | 10.3 @ 0 °C | 1.13 | 63.6 @ 30 °C |
| (L)-Ephedrine HCl | 50-98-6 | 218 | 2.04E ⁻¹⁰ @ 25 °C | pH 5.9 @ 1/200 dil. ⁽³⁾ | -2.45 | 25 ⁽⁶⁾ |
| MDEA | 82801-81-8 | — | — | — | — | — |
| MDMA HCl | 42542-10-9 | 148-149 ⁽²⁾ | — | — | — | — |
| (D)-Methamphetamine | 537-46-2 | — | 0.163 @ 25 °C | 9.87 @ 25 °C | 2.07 | 1.33 @ 25 °C |
| (D)-Methamphetamine HCl | 51-57-0 | 170-175 ⁽²⁾ | — | — | — | — |
| Phencyclidine | 77-10-1 | 46.5 | — | 8.29 ⁽⁶⁾ | 4.69 | — |
| Phencyclidine HCl | 956-90-1 | 233-235 ⁽²⁾ | — | — | — | — |
| Phentermine | 122-09-8 | — | 0.0961 @ 25 °C | — | 1.90 | 1.86 @ 25 °C |
| Phentermine HCl | 1197-21-3 | 198 ⁽²⁾ | — | — | — | — |
| (±) Phenylpropanolamine | 14838-15-4 | — | 0.000867 @ 25 °C | 9.44 @ 20 °C | 0.67 | 14.9 @ 25 °C |
| (±) Phenylpropanolamine HCl | 154-41-6 | 194 | — | — | -2.75 | — |
| (L)-Norephedrine | 492-41-1 | 51-53 ⁽³⁾ | — | — | — | — |
| 1S,2S (+)-Norephedrine | 36393-56-3 | 77.5-78 | 0.000867 @ 25 °C | 9.44 @ 20 °C | 0.83 | 14.9 @ 25 °C |
| 1S,2S (+)-Norephedrine HCl | 492-39-7 | — | — | pH 5.9-6.1 in aq. soln. ⁽³⁾ | 0.22 | 2 @ 25 °C |
| (D)-Pseudoephedrine | 90-82-4 | 119 | 0.00083 @ 25 °C | 10.3 @ 0 °C | 0.89 | 10.6 @ 25 °C |
| (D)-Pseudoephedrine HCl | 345-78-8 | 181-182 ⁽²⁾ | — | pH 5.9 @ 1/200 dil. ⁽³⁾ | — | — |

(1) Handbook of Physical Properties of Organic Chemicals unless otherwise noted [21].

(2) Merck Index [17].

(3) Sigma-Aldrich MSDS [19].

(4) Negative log of the acid dissociation constant for the amine in aqueous solution.

(5) Log P = octanol-water partition coefficient.

(6) Temperature not given in source.

Table 3. Synonyms of analytes

| Generic names ⁽¹⁾ | Trade and street names ⁽²⁾ | Additional names ⁽³⁾ |
|---|---|--|
| (DL)-Amphetamine; (±)-Amphetamine | Benzedrine; Phenedrine; bennies | (±)- α -Methylbenzeneethanamine ⁽⁴⁾ ; dl- α -Methylphenethylamine ⁽⁴⁾ ; dl-1-Phenyl-2-aminopropane; (±)-Desoxynorephedrine |
| (D)-Amphetamine; (+)-Amphetamine | Dextroamphetamine; Dexedrine; dexies | (S)- α -Methylbenzeneethanamine ⁽⁴⁾ ; d- α -Methylphenethylamine ⁽⁴⁾ ; d-1-phenyl-2-aminopropane; d- β -Phenylisopropylamine |
| (L)-Amphetamine; (-)-Amphetamine | Levoamphetamine; component of Adderall | (R)- α -Methylbenzeneethanamine ⁽⁴⁾ ; l- α -Methylphenethylamine ⁽⁴⁾ ; l-1-phenyl-2-aminopropane; (-)-1-phenyl-2-aminopropane |
| Caffeine | Component (with ephedrine) of cloud 9 and herbal XTC | 3,7-Dihydro-1,3,7-trimethyl-1H-purine-2,6-dione ⁽⁴⁾ ; 1,3,7-Trimethylxanthine |
| (DL)-Ephedrine; (±)-Ephedrine | Ephedral; Racephedrine; Sanedrine | (<i>R</i> *, <i>S</i> *)-(±)- α -(1-(Methylamino)ethyl)benzenemethanol; DL- α -(1-(Methylamino)ethyl)benzyl alcohol; <i>dl</i> -Ephedrine |
| (L)-Ephedrine; (-)-Ephedrine; (1 <i>R</i> ,2 <i>S</i>)-(-)-Ephedrine; <i>l</i> -Ephedrine | Primatene; Xenadrine; Ma Huang (<i>Ephedra sinica</i> and other species ⁽⁵⁾); (with caffeine) cloud 9 and herbal ecstasy | (<i>R</i> -(<i>R</i> *, <i>S</i> *)- <i>a</i> -(1-Methylaminoethyl)benzenemethanol; L-erythro-2-(Methylamino)-1-phenylpropan-1-ol; (1 <i>R</i> ,2 <i>S</i>)-(-)-2-Methylamino-1-phenyl-1-propanol; (-)- α -(1-Methylamino-ethyl)-benzyl alcohol; (-)-1-hydroxy-2-methylamino-1-phenylpropane; L(-)-Ephedrine |
| (D)-Ephedrine | | (1 <i>S</i> ,2 <i>R</i>)-(+)-2-Methylamino-1-phenyl-1-propanol; (+)-Ephedrine |
| MDEA | MDE; Eve | (±)-3,4-Methylenedioxy-N-ethylamphetamine; N-ethyl- α -methyl-1,3-benzodioxole-5-ethanamine |
| MDMA | Adam, ecstasy | <i>N</i> , α -Dimethyl-3,4-1,3-benzodioxole-5-ethanamine; 3,4-Methylenedioxymethamphetamine |
| (DL)-Methamphetamine; (±)-Methamphetamine | | <i>N</i> , α -Dimethylbenzeneethanamine ⁽⁴⁾ ; <i>N</i> , α -Dimethylphenethylamine; <i>dl</i> -Desoxyephedrine; N-methyl- β -phenylisopropylamine |
| (D)-Methamphetamine; (+)-Methamphetamine; <i>d</i> -Methamphetamine | Methedrine; Desoxyn; chalk; crank; crystal; glass; ice; meth; speed; upper | (<i>S</i>)- <i>N</i> , α -Dimethylbenzeneethanamine; (<i>S</i>)-(+)- <i>N</i> , α -Dimethyl-phenethylamine ⁽⁴⁾ ; <i>d</i> -1-Phenyl-2-methylaminopropane; <i>d</i> -Desoxyephedrine; <i>d</i> -N-methyl- β -phenyl-isopropylamine |
| (L)-Methamphetamine; (-)-Methamphetamine | Component in decongestant vapor inhaler (Vick's brand) | (<i>R</i>)-(-)- <i>N</i> , α -Dimethylphenethylamine; (-)-Deoxyephedrine; (-)-2-(Methylamino)-1-phenylpropane |
| Phencyclidine | Sernylan; Sernyl; angel dust; PCP; peace pill | 1-(1-Phenylcyclohexyl) piperidine ⁽⁴⁾ |
| Phentermine | Fastin; Normephterimine | α , α -Dimethylbenzeneethanamine ⁽⁴⁾ ; α , α -Dimethylphenethylamine ⁽⁴⁾ ; 1,1-Dimethyl-2-phenylethylamine; <i>a</i> -Benzylisopropylamine |
| (DL)-Norephedrine; (±)-Norephedrine | (±)-Phenylpropanolamine; Obestat; Phenedrine; | (<i>R</i> *, <i>S</i> *)-(±)- <i>a</i> -(1-Aminoethyl)benzenemethanol ⁽⁴⁾ ; -(±)- <i>a</i> -(1-Amino-ethyl)benzyl alcohol ⁽⁴⁾ ; (±)-2-Amino-1-phenyl-1-propanol |
| (L)-Norephedrine; (-)-Norephedrine | Natural form found in <i>Ephedra sinica</i> and other species ⁽⁵⁾ | (1 <i>R</i> ,2 <i>S</i>)- 2-Amino-1-phenyl-1-propanol; (1 <i>R</i> ,2 <i>S</i>)-Norephedrine; <i>l</i> -erythro-2-Amino-1-phenylpropan-1-ol |
| (D)-Norephedrine; (+)-Norephedrine | Metabolite of cathinone in urine of Khat users. | (1 <i>S</i> ,2 <i>R</i>)- 2-Amino-1-phenyl-1-propanol; (1 <i>S</i> ,2 <i>R</i>)-Norephedrine; <i>d</i> -erythro-2-Amino-1-phenylpropan-1-ol |
| (+)-Norpseudoephedrine; Cathine | Amorphan; Adiposettin; Reduform; found naturally in Khat plant | (<i>R</i> *, <i>R</i> *)- <i>a</i> -(1-Aminoethyl)benzenemethanol ⁽⁴⁾ ; <i>d</i> -threo- <i>a</i> -2-Amino-1-hydroxy-1-phenylpropane; 1 <i>S</i> ,2 <i>S</i> -(+)-Norpseudoephedrine |
| L-(+)-Pseudoephedrine; (+)-Pseudoephedrine; <i>d</i> -Pseudoephedrine | Afrinol; Novafed; Sinufed; Sudafed; natural form found in <i>Ephedra sinica</i> and other species ⁽⁵⁾ | (<i>S</i> -(<i>R</i> *, <i>R</i> *)- <i>a</i> -(1-(Methylamino)ethyl)benzenemethanol; (1 <i>S</i> ,2 <i>S</i>)-(+)-2-Methylamino-1-phenylpropanol; <i>d</i> -(α -(1-Methylamino)-ethyl)benzyl alcohol; (1 <i>S</i> ,2 <i>S</i>)-(+)-Pseudoephedrine; <i>d</i> -threo-2-Methylamino-1-phenylpropan-1-ol; (+)- ψ -Ephedrine |
| D-(-)-Pseudoephedrine; (-)-Pseudoephedrine | | (1 <i>R</i> ,2 <i>R</i>)-(-)-Pseudoephedrine; (-)- ψ -Ephedrine; <i>l</i> -threo-2-Methylamino-1-phenylpropan-1-ol; (+)- ψ -Ephedrine |

(1) Common or generic names. Salts forms are not given for simplicity.

(2) Trade and street names are exemplary, not exhaustive. Street names change over time and by locality. Salts and free base forms are not distinguished.

(3) Other names from Merck Index [17], NIOSH Registry of Toxic Effects of Chemical Substances [18], and MSDS sheets [19,20]. NOTE: For amphetamine and methamphetamine the prefixes R-, D-, d-, and (+)-, although they mean different things, are essentially synonymous for the dextrorotatory stereoisomer and S-, L-, l-, and (-)- are essentially synonymous for the levorotary stereoisomer. Many other synonyms exist.

(4) Uninverted CAS name as given in Merck Index [17].

(5) Extracts of *Ephedra* species contain various amounts of (+)-Norephedrine, (-)-N-methylephedrine, and (+)-N-methylpseudoephedrine. (+)-Norephedrine is reduced to amphetamine and N-methylephedrine and N-methylpseudoephedrine reduce to N,N-dimethylamphetamine [22, 23]. The presence of these latter two compounds in methamphetamine samples indicate that *Ephedra* spp. extracts may have been used in the synthesis [24].

Table 4. Limit of detection (LOD), method detection limit (MDL), and sample storage stability⁽¹⁾

| Compound | Int. std. ⁽²⁾ | Estimated LOD ⁽³⁾ | | Estimated MDL ⁽⁴⁾ | | Storage Stability ⁽⁵⁾ | |
|---------------------------------|--------------------------|------------------------------------|------------------------------------|------------------------------|--------------------------|----------------------------------|--------------|
| | | µg/sample liq. stds ⁽⁶⁾ | µg/sample liq. stds ⁽⁷⁾ | µg/sample cotton gauze | µg/sample Synthetic Wipe | 30 days 4 °C | 7 days 22 °C |
| (D)-Amphetamine | D11-Amp | 0.1 | 0.1 | 0.02 | | 100.5 | 94.5 |
| | D14-Met | 0.1 | 0.05 | 0.02 | 0.02 | 99.7 | 87.9 |
| | NMPhen | 0.1 | | 0.04 | | - | - |
| Cocaine | D11-Amp | 0.6 | | 0.2 ⁽⁹⁾ | | 99.3 | 98.8 |
| | D14-Met | 0.4 | | 0.1 ⁽⁹⁾ | 0.1 ⁽⁹⁾ | 98.5 | 91.9 |
| | NMPhen | 0.4 | | 0.1 ⁽⁹⁾ | | - | - |
| (L)-Ephedrine | D11-Amp | 0.2 | 0.2 | 0.02 | | 95.6 | 97.2 |
| | D14-Met | 0.1 | 0.1 | 0.02 | 0.02 | 94.8 | 90.5 |
| | NMPhen | 0.1 | | 0.02 | | - | - |
| MDEA | N-PAmp | 0.1 | | 0.06 | 0.1 | 98.9 | 102.1 |
| MDMA | D11-Amp | 0.1 | | 0.02 | | 99.7 | 111.1 |
| | D14-Met | 0.1 | | 0.02 | 0.04 | 98.9 | 103.2 |
| | NMPhen | 0.1 | | 0.03 | | - | - |
| (D)-Methamphetamine | D11-Amp | 0.2 | 0.07 | 0.02 | | 98.7 | 100.6 |
| | D14-Met | 0.1 | 0.05 | 0.02 | 0.02 | 98.0 | 93.5 |
| | NMPhen | 0.1 | | 0.02 | | - | - |
| Phencyclidine | D11-Amp | 0.6 | | 0.1 ⁽⁹⁾ | | 103.7 | 105.2 |
| | D14-Met | 0.4 | | 0.1 ⁽⁹⁾ | 0.5 ⁽⁹⁾ | 102.9 | 97.7 |
| | NMPhen | 0.4 | | 0.1 ⁽⁹⁾ | | - | - |
| Phentermine | D11-Amp | 0.2 | | 0.03 | | 102.0 | 101.5 |
| | D14-Met | 0.1 | | 0.03 | 0.03 | 101.1 | 94.3 |
| | NMPhen | 0.1 | | 0.04 | | - | - |
| (±)-Norephedrine ⁽⁸⁾ | D11-Amp | 0.1 | 0.05 | 0.03 | | 94.3 | 92.7 |
| | D14-Met | 0.1 | 0.05 | 0.03 | 0.03 | 93.6 | 86.2 |
| | NMPhen | 0.1 | | 0.03 | | - | - |
| Pseudoephedrine | D11-Amp | 0.2 | 0.2 | 0.02 | | 100.4 | 97.9 |
| | D14-Met | 0.1 | 0.1 | 0.02 | 0.02 | 99.6 | 91.1 |
| | NMPhen | 0.1 | | 0.02 | | - | - |

(1) Backup Data Report [4].

(2) Internal standards: D11-Amp = Amphetamine-D₁₁, D14-Met = Methamphetamine-D₁₄, NMPhen = N-Methyl phenethylamine, N-PAmp = N-Propyl amphetamine.

(3) LODs vary according to individual GC columns, instrument conditions and cleanliness, media interferences, and internal standards used. LODs were calculated on liquid standards using the procedure of Burkart (LODs for linear calibration curves are calculated as 3 times the standard error of the lowest three standards analyzed in replicate divided by the slope of the calibration curve) [12].

(4) MDLs are provided to satisfy regulatory agencies requiring this expression of sensitivity. These MDLs are calculated as the standard deviation of six replicates on spiked media analyzed at the 0.1 µg/sample level (except as noted) times the Student's t value for 6 replicates (3.365). (Normally 7 replicates are required.)

(5) Cotton gauze samples were spiked at 3 µg/sample per analyte. Six samples were analyzed immediately after preparation. Six samples were stored at room temperature (about 22 °C) for 7 days and then analyzed. Eighteen samples were stored at >6 °C. Of the 18 samples stored at >6 °C, six each were analyzed at 7 and 21 days and three each were analyzed at 14 and 30 days (Backup Data Report [4]). Apparent recoveries vary according to internal standard used.

(6) These LODs are conservative since the lowest calibration standard for these determinations was 0.1 µg/sample. Lower LODs are achievable with lower concentration calibration standards and operation of the mass spectrometer in the SIM mode.

(7) Typical LODs for a five point calibration curve with single standards at each concentration level. The lowest calibration standard for these determinations was 0.05 µg/sample.

(8) (±)-Norephedrine = (±)-phenylpropanolamine.

(9) MDLs for cocaine and phencyclidine were determined from the 0.3 µg/sample level because the GC peaks for the 0.1 µg/sample level were un-measurable. Precisions at the 0.3 µg/sample level were such that the MDLs calculated to 0.1 µg/sample anyway. This value may be realistic since the 0.1 µg/sample level samples had been stored for one month prior to analysis which may have affected stability.

Table 5. Example of mass spectrometer operation parameters for selected ion monitoring mode⁽¹⁾

| Heptafluorobutyl-trimethyl-silyl derivatives | | Scan window ⁽²⁾ | Acquisition ions (<i>m/z</i>) per group ⁽³⁾ | | | | | | | | | |
|--|--|----------------------------|--|-----|-----|-----|-----|-----|-----|-----|-----|-----|
| Acquisition Group 1 | | 8.20 to 10.20 | 104 | 118 | 128 | 132 | 210 | 213 | 240 | 244 | 254 | 261 |
| Acquisition Group 2 | | 10.20 to 13.20 | 179 | 240 | 254 | 282 | 296 | 456 | | | | |
| Acquisition Group 3 | | 13.20 to 19.00 | 82 | 162 | 182 | 200 | 242 | 254 | 268 | | | |

| GC Peak No. ⁽⁴⁾ | Target Analytes and Internal Standards | Retention Time ⁽⁶⁾ (min) | Primary Ion (<i>m/z</i>) ⁽⁷⁾ (Quantification Ion) | Secondary ion and approximate relative abundance ⁽⁸⁾ (relative to the Primary Ion) | |
|----------------------------|---|-------------------------------------|---|---|------|
| Acquisition Group 1: | | | | | |
| 13 | Amphetamine-D ₁₁ (IS) ⁽⁹⁾ | 8.46 | 244 | 128 | 70% |
| 5 | Amphetamine | 8.54 | 240 | 118 | 70% |
| 92 | Phentermine | 8.72 | 254 | 132 | 12% |
| 81 | N-Methyl phenethylamine (IS) ⁽⁹⁾ | 8.54 | 240 | 104 | 100% |
| 68 | Methamphetamine-D ₁₄ (IS) ⁽⁹⁾ | 9.86 | 261 | 213 | 30% |
| 64 | Methamphetamine | 9.94 | 254 | 210 | 35% |
| Acquisition Group 2: | | | | | |
| 95 | Phenylpropanolamine | 10.49 | 179 | 240 | 18% |
| 97 | N-Propylamphetamine (IS) ⁽⁹⁾ | 11.05 | 282 | 240 | 85% |
| 36 | Ephedrine | 11.40 | 179 | 254 | 17% |
| 98 | Pseudoephedrine | 11.68 | 179 | 254 | 15% |
| 32 | Dibromooctafluorobiphenyl ⁽¹⁰⁾ | 12.82 | 296 | 456 | 100% |
| Acquisition Group 3: | | | | | |
| 59 | MDMA | 13.81 | 254 | 162 | 80% |
| 57 | MDEA | 14.19 | 268 | 162 | 60% |
| 86 | Phencyclidine | 15.62 | 200 | 242 | 35% |
| 27 | Cocaine | 18.65 | 182 | 82 | 110% |

- (1) In this example, 10 analytes and 5 internal standards are grouped into 3 acquisition groups having no more than 10 primary and secondary ions per acquisition group. For 6 analytes and internal standards or less, one acquisition group may be sufficient.
- (2) Scan window is in minutes. Actual times are dependent upon GC column and instrument conditions.
- (3) Ions (*m/z*) in bold numbers are suggested primary (quantification) ions. For best signal to noise ratio, do not exceed 10 ions per acquisition group. Dwell time per ion (*m/z*) is 50 milliseconds.
- (4) GC peak numbers are those in Figures 1 and 2 and Table 10.
- (5) The list of analytes and internal standards shown is an example. Analyte(s) and internal standard(s) must be selected according to analytical objectives.
- (6) Retention times are dependent upon GC column and instrument conditions.
- (7) The better ions for quantification are usually the base peak or those with masses >100 *m/z* and relative abundances >50% of the base peak. These minimize interference from co-eluting hydrocarbons. The suggested primary ions are not necessarily the base peaks in the mass spectra of the analytes, especially if the base peaks are ions common to aromatics (e.g., *m/z* 91) and paraffinic or olefinic hydrocarbons (e.g., *m/z* 42, 57, and 58). Suggested ions for other analytes and internal standards are given in Table 10.
- (8) Secondary ions may be used for quantification if the primary ion encounters interference. Secondary ions improve qualitative identification for SIM analyses. The relative abundances given are approximate (± 10 to 20%) and depend upon specific instrument tuning and conditions. They are relative to the primary ion and not necessarily to the base peak in the mass spectrum of each analyte. The relative abundance of secondary ions for each analyte needs to be determined from a mass spectrum acquired on the instrument to be used.
- (9) (IS) = internal standard. Internal standards must be paired with the appropriate analytes. Tables 7a and 7b give precision and accuracy data for various pairings. Other potentially useful internal standards are given in Tables 8a, 8b, and 10. Highly deuterated analogs of the target analytes are preferred, where available.
- (10) Dibromooctafluorobiphenyl is an optional secondary internal standard useful for monitoring autosampler performance and instrument tuning. A shift in the mass axes or the relative abundance of *m/z* 296 to that of *m/z* 456 throughout an analytical sequence will help signal degraded tuning.

Table 6. Suggested spiking schedule for calibration standards and quality control samples

| Add the following to clean shipping containers (e.g., 50-mL polypropylene centrifuge tubes) in the following order. | | | | | | | |
|---|----------------------------------|---|--|--|--|---|---|
| Name | Number of Wipes ^(1,2) | Volume ⁽²⁾ of Isopropanol or Methanol ⁽³⁾ | Volume ⁽²⁾ of Internal Standard Spiking Solution ^(4,5) | Volume of Target Analyte Spiking Solution ^(5,6) | Volume of Spiking Solution diluted 1/20 ^(5,7) | Volume ⁽²⁾ of Desorption Solution ⁽⁸⁾ | Resulting µg/sample as Free Base ⁽⁹⁾ |
| Calibration Standards⁽¹⁰⁾ | | | | | | | |
| CS0 | 0 | 3 mL | 60 µL | | 0.0 µL | 30 mL | 0.00 |
| CS1 | 0 | 3 mL | 60 µL | | 2 µL | 30 mL | 0.02 |
| CS2 | 0 | 3 mL | 60 µL | | 5 µL | 30 mL | 0.05 |
| CS3 | 0 | 3 mL | 60 µL | | 10 µL | 30 mL | 0.1 |
| CS4 | 0 | 3 mL | 60 µL | | 20 µL | 30 mL | 0.2 |
| CS5 | 0 | 3 mL | 60 µL | | 60 µL | 30 mL | 0.6 |
| CS6 | 0 | 3 mL | 60 µL | 10 µL | | 30 mL | 2.0 |
| CS7 | 0 | 3 mL | 60 µL | 30 µL | | 30 mL | 6.0 |
| CS8 | 0 | 3 mL | 60 µL | 100 µL | | 30 mL | 20 |
| CS9 | 0 | 3 mL | 60 µL | 300 µL | | 30 mL | 60 |
| CS10 | 0 | 3 mL | 60 µL | 1000 µL | | 30 mL | 200 |
| Quality Control Samples⁽¹¹⁾ | | | | | | | |
| QB (media blank) | 1 | 3 mL | 60 µL | 0.0 µL | | 30 mL | 0.0 |
| QC (matrix spike) | 1 | 3 mL | 60 µL | 3-300 µL | or 20-60 µL | 30 mL | 0.2-60 |
| QD (matrix spike duplicate) | 1 | 3 mL | 60 µL | 3-300 µL | or 20-60 µL | 30 mL | 0.2-60 |

- (1) Gauze wipes may be added to the calibration standards but are not necessary if cotton gauze is used. Blank gauze wipes must always be added to the quality control samples, QB, QC, and QD.
- (2) a. If a sample consists of 2 gauze wipes, the volume of desorption solution must be increased to 40 mL to accommodate the second wipe. The shipping container should be a 50-mL polypropylene centrifuge tube or equivalent to accommodate the extra volume of desorption solution for 2 wipes. It is not critical to know the exact volume of desorption solution and wetting alcohol used per sample. It only needs to be enough to cover the samples and to permit free percolation through the samples. See step 7.
b. If a set of samples consists predominantly of 2 gauze wipes, the QB, QC, and QD should also consist of 2 wipes and treated as per the samples. The volume of isopropanol (or methanol) added to the QC samples should be increased to 4 mL for 2 gauze wipes to simulate samples containing 2 gauze wipes.
- (3) If methanol was used for wipe sampling, it should also be used in the calibration standards, blanks, and QCs instead of isopropanol.
- (4) Concentration of internal standards in the internal standard spiking solution is approximately 200 µg/mL as the free base. It is critical to know the exact volume of internal standard spiking solution that is added to the calibration standards, samples, blanks, and quality control samples. The volume spiked into the samples may vary with sample size but the volume spiked into each of the calibration standards must not vary. See step 7b.
- (5) For quality control samples, spike onto wipe media within the shipping container. For liquid calibration standards (in lieu of media calibration standards), spike into the isopropanol (or methanol).
- (6) Concentration of analytes in the target analyte spiking solution is approximately 200 µg/mL as the free base.
- (7) Concentration of analytes in the diluted spiking solution for this table is approximately 10.0 µg/mL as the free base and can be prepared by diluting 100 µL of the target analyte spiking solution to 2 mL in methanol.
- (8) Desorption solution is 0.1 M sulfuric acid in deionized water.
- (9) This is µg per total sample irrespective of the total desorption solution volume or the area wiped.
- (10) Select 6 calibration standards from the list to cover the analytical range plus the blank.
- (11) Prepare one set of quality control samples for every 20 samples or less.

Table 7a. Precision and accuracy in scan mode for cotton gauze⁽¹⁾

| Compound | Internal Standard ⁽²⁾ | Range ⁽³⁾ µg/sample | Accuracy | Overall Precision \hat{S}_{RT} | Bias | |
|---------------------------------|----------------------------------|-----------------------------------|----------|----------------------------------|---------|--------------------|
| | | | | | Average | Range |
| (D)-Amphetamine | D ₁₁ -Amp | 0.1-30 | 8.1 | 0.0412 | -0.0054 | -0.0386 to +0.0428 |
| | D ₁₄ -Met | 0.1-30 | 10.3 | 0.0472 | -0.0227 | -0.0844 to +0.0199 |
| | NMPhen | 0.1-30 | 13.2 | 0.0662 | -0.0120 | -0.0931 to +0.0290 |
| Cocaine | D ₁₁ -Amp | 1.0-30 | 15.8 | 0.0469 | +0.0810 | +0.0416 to +0.1375 |
| | D ₁₄ -Met | 3-30 | 13.3 | 0.0422 | +0.0631 | +0.0003 to +0.1294 |
| | NMPhen | 0.3-30 | 20.2 | 0.0729 | +0.0823 | -0.0092 to +0.1359 |
| (L)-Ephedrine | D ₁₁ -Amp | 0.1-30 | 9.8 | 0.0499 | -0.0052 | -0.0608 to +0.0262 |
| | D ₁₄ -Met | 0.1-30 | 9.2 | 0.0397 | -0.0266 | -0.0463 to +0.0221 |
| | NMPhen | 0.1-30 | 11.2 | 0.0493 | -0.0284 | -0.0775 to +0.0302 |
| MDEA | N-PAmp | 0.3-29 | 12.4 | 0.0618 | +0.0127 | -0.0475 to +0.0869 |
| MDMA | D ₁₁ -Amp | 0.1-27 | 14.3 | 0.0568 | +0.0497 | +0.0104 to +0.1197 |
| | D ₁₄ -Met | 0.1-27 | 13.1 | 0.0558 | +0.0389 | -0.0189 to +0.0978 |
| | NMPhen | 0.3-27 | 11.9 | 0.0605 | +0.0007 | -0.0570 to +0.0360 |
| (D)-Methamphetamine | D ₁₁ -Amp | 0.1-10 | 9.2 | 0.0395 | +0.0270 | -0.0289 to +0.0923 |
| | D ₁₄ -Met | 0.1-30 | 5.9 | 0.0302 | +0.0015 | -0.0440 to +0.0592 |
| | NMPhen | 0.3-30 | 6.9 | 0.0334 | +0.0113 | -0.0534 to +0.0448 |
| Phencyclidine | D ₁₁ -Amp | 0.3-30 | 17.2 | 0.0639 | +0.0670 | +0.0059 to +0.1222 |
| | D ₁₄ -Met | 0.3-30 | 15.9 | 0.0648 | +0.0521 | -0.0386 to +0.1039 |
| | NMPhen | 0.3-30 | 16.0 | 0.0638 | +0.0547 | -0.0474 to +0.0886 |
| Phentermine | D ₁₁ -Amp | 0.1-30 | 10.1 | 0.0444 | +0.0261 | -0.0067 to +0.0912 |
| | D ₁₄ -Met | 0.1-30 | 10.4 | 0.0527 | +0.0041 | -0.0600 to +0.0674 |
| | NMPhen | 1.0-30 | 8.2 | 0.0400 | +0.0121 | -0.0378 to +0.0407 |
| (±)-Norephedrine ⁽⁴⁾ | D ₁₁ -Amp | 0.1-30 | 12.2 | 0.0571 | +0.0241 | +0.0500 to +0.0610 |
| | D ₁₄ -Met | 0.1-30 | 12.5 | 0.0638 | -0.0005 | -0.0674 to +0.0708 |
| | NMPhen | 0.1-30 | 13.3 | 0.0675 | +0.0036 | -0.0533 to +0.0476 |
| Pseudoephedrine | D ₁₁ -Amp | 0.1-30 | 10.0 | 0.0507 | -0.0059 | -0.0530 to +0.0441 |
| | D ₁₄ -Met | 0.1-30 | 12.3 | 0.0507 | -0.0392 | -0.0737 to +0.0301 |
| | NMPhen | 1.0-30 | 15.6 | 0.0716 | -0.0350 | -0.0813 to +0.0617 |

(1) Backup Data Report [4]. Values are for the heptafluorobutyl and mixed heptafluorobutyl-trimethylsilyl derivatives and analysis by GC-MS in scan mode. Each sample consisted of a pair of 3" x 3" 12-ply cotton gauze pads. There were 6 replicate samples per concentration level and six concentration levels evaluated from approximately 0.1 to 30 µg/sample.

(2) Internal Standards Deuterated: Non-deuterated:
 D₁₁-Amp = Amphetamine-D₁₁ NMPhen = N-Methyl phenethylamine
 D₁₄-Met = Methamphetamine-D₁₄ N-PAmp = N-Propyl amphetamine

(3) Range used for calculation of precision, accuracy, and bias. The entire range studied for all analytes was approximately 0.1 to 30 µg/sample (1xLOQ to 300xLOQ).

(4) (±)-Norephedrine = (±)-phenylpropanolamine.

Table 7b. Precision and accuracy in scan mode for synthetic wipe⁽¹⁾

| Compound | Internal Standard ⁽²⁾ | Range ⁽³⁾ µg/ sample | Accuracy | Overall Precision \hat{S}_{RT} | Bias | |
|---------------------------------|----------------------------------|------------------------------------|----------|----------------------------------|---------|--------------------|
| | | | | | Average | Range |
| (D)-Amphetamine | D14-Met | 0.1-30 | 17.2 | 0.0611 | -0.0712 | -0.1066 to -0.0468 |
| Cocaine | D14-Met | 0.3-30 | 17.7 | 0.0901 | -0.0014 | -0.0246 to +0.0252 |
| (L)-Ephedrine | D14-Met | 0.1-30 | 10.7 | 0.0432 | -0.0362 | -0.0638 to -0.0039 |
| MDEA | N-PAmp | 0.3-29 | 9.6 | 0.0425 | -0.0240 | -0.0453 to +0.0416 |
| MDMA | D14-Met | 0.3-27 | 11.4 | 0.0498 | -0.0297 | -0.0612 to +0.0095 |
| (D)-Methamphetamine | D14-Met | 0.1-30 | 8.7 | 0.0430 | -0.0114 | -0.0483 to +0.0625 |
| Phencyclidine | D14-Met | 0.3-30 | 13.0 | 0.0391 | +0.0658 | +0.0216 to +0.1418 |
| Phentermine | D14-Met | 0.3-30 | 10.4 | 0.0295 | -0.0560 | -0.0917 to -0.0266 |
| (±)-Norephedrine ⁽⁴⁾ | D14-Met | 0.1-30 | 12.6 | 0.0577 | +0.0282 | -0.0220 to +0.0937 |
| Pseudoephedrine | D14-Met | 0.1-30 | 13.5 | 0.0592 | -0.0352 | -0.1001 to -0.0020 |

- (1) Backup Data Report [4]. Values are for the heptafluorobutyl and mixed heptafluorobutyl-trimethylsilyl and analysis by GC-MS in scan mode (see p 9109-1 for GC and MS conditions). Each sample consisted of a pair of 3" x 3" 12-ply cotton gauze pads. There were 6 replicate samples per concentration level and six concentration levels evaluated from approximately 0.1 to 30 µg/sample.
- (2) Internal Standards: D14-Met = Methamphetamine-D₁₄, N-PAmp = N-Propyl amphetamine.
- (3) Range used for calculation of precision, accuracy, and bias. The entire range studied for all analytes was approximately 0.1 to 30 µg/sample (1xLOQ to 300xLOQ).
- (4) (±)-Norephedrine = (±)-phenylpropanolamine.

Table 8a. Recommended internal standards⁽¹⁾ and best application

| COMPOUND NAME | CAS | MW as free base | Quant. Ion | Secondary Ion | COMMENTS |
|-------------------------------------|---------------|--------------------|---------------|------------------|---|
| (±)-Amphetamine-D ₁₁ | not available | 146.12 | 244 | 128 | Preferred analog for amphetamine |
| (±)-Amphetamine-D ₈ | 145225-00-9 | 143.15 | 243 | 126 | Alternate for amphetamine-D ₁₁ |
| (±)-Amphetamine-D ₆ | not available | 141.16 | 244 | 123 | Alternate for amphetamine-D ₁₁ |
| (±)-Methamphetamine-D ₁₄ | not available | 163.12 | 261 | 213 | Preferred methamphetamine analog |
| (±)-Methamphetamine-D ₁₁ | 152477-88-8 | 160.15 | 260 | 213 | Alternate for methamphetamine-D ₁₄ |
| (±)-Methamphetamine-D ₉ | not available | 158.16 | 261 | 213 | Alternate for methamphetamine-D ₁₄ |
| N-Methylphenethylamine | 589-08-2 | 135.23 | 240 | 104 | Alternate for methamphetamine-D ₁₄ |
| Phencyclidine-D ₅ | 60124-86-9 | 248.35 | 205 | 96 | Use only for phencyclidine |
| MDEA-D ₆ ⁽²⁾ | 160227-44-1 | 213.22 | 268 | 162 | Use only for MDEA |
| N-Propylamphetamine ⁽²⁾ | not available | 177.29 | 282 | 240 | Alternate for MDEA-D ₆ |

- (1) Care must be exercised in the selection of internal standards for each analyte because of differences in derivatization efficiencies due to structural differences.
 - a. Deuterated analogs of each target analyte may be acceptable as internal standards if they are isotopically pure enough and their ions do not interfere with the quantification ions (usually base peaks) of the target analyte, especially at the limit of detection for the target analyte. Conversely it is also important that ions in the target analyte, especially at high concentrations, do not interfere with the quantification ion (usually base peaks) of any deuterated analog used as the internal standard.
 - b. The more highly deuterated an analog, the more it will chromatographically separate from the target analyte, reducing interference from common ions.
 - c. Phentermine and mephentermine have been used as internal standards. Such use is not advised in this method because of their reported occasional use as adulterants in certain illicit drugs such as MDMA.
- (2) N-Propylamphetamine and MDEA-D₆ are only applicable to MDEA and other hindered amines (e.g., fenfluramine and MBDB) due to similar steric hindrance at the nitrogen (N-ethyl or N-propyl substitution) which affects derivatization efficiency.

Table 8b. Recommended best application of internal standards⁽¹⁾

| Target Analyte | Recommended Deuterated Internal Standards | | | | Recommended Alternate Non-deuterated Internal Standards ⁽³⁾ | |
|---------------------------------|--|--|------------------------------------|------------------------------|--|------------------------------------|
| | Amphetamine-D ₁₁ ⁽²⁾ | Methamphetamine-D ₁₄ ⁽²⁾ | MDEA-D ₆ ⁽¹⁾ | Phencyclidine-D ₅ | N-Methylphenethylamine | N-Propylamphetamine ⁽¹⁾ |
| Amphetamine | X | X | | | X | |
| Cocaine | X | X | | | X | |
| Ephedrine | X | X | | | X | |
| MDEA | | | X | | | X |
| MDMA | X | X | | | X | |
| Methamphetamine | X | X | | | X | |
| Phencyclidine | X | X | | X | X | |
| Phentermine | X | X | | | X | |
| (±)-Norephedrine ⁽⁴⁾ | X | X | | | X | |
| Pseudoephedrine | X | X | | | X | |

- (1) N-Propylamphetamine and MDEA-D₆ are only applicable to MDEA and other hindered amines (e.g., fenfluramine and MBDB) due to similar steric hindrance at the nitrogen (N-ethyl or N-propyl substitution) which affects derivatization efficiency.
- (2) The alternate deuterated compounds listed in part A above may be used. Avoid ring-labeled amphetamine-D₅ (CAS 65538-33-2) since the primary (quantification) ion is the same as for amphetamine and GC peaks overlap significantly. Also avoid methamphetamine-D₅ (CAS 60124-88-1) since GC peaks significantly overlap.
- (3) The listed non-deuterated compounds are acceptable as internal standards for the listed target analytes for the applicable ranges and limits of detection listed in Tables 7a and 7b respectively. Non-deuterated internal standards might not be permissible. Consult regulations of agency having legal jurisdiction.
- (4) (±)-Norephedrine is the same as (±)-phenylpropanolamine.

Table 9a. Recovery from wall (latex painted) with various solvents; one wipe compared with the sum of two wipes^(1,2)

| Test Compounds ⁽⁵⁾ | Water ⁽³⁾ | | | Isopropanol | | | Methanol | | |
|-------------------------------|----------------------|------|---------------------------------------|-------------|------|---------------------------------------|------------|------|---------------------------------------|
| | First Wipe | | Plus Second Wipe ⁽⁴⁾ | First Wipe | | Plus Second Wipe ⁽⁴⁾ | First Wipe | | Plus Second Wipe ⁽⁴⁾ |
| | Percent | %RSD | Percent | Percent | %RSD | Percent | Percent | %RSD | Percent |
| Amphetamine | 51 | 14 | 56 | 67 | 6.0 | 78 | 90 | 4.0 | 96 |
| Cocaine | 36 | 22 | 36 | 69 | 22 | 80 | 89 | 9.1 | 94 |
| Ephedrine | 48 | 23 | 52 | 76 | 7.4 | 85 | 91 | 4.4 | 96 |
| MDMA | 40 | 20 | 44 | 61 | 9.0 | 70 | 88 | 5.3 | 94 |
| MDEA | 45 | 22 | 50 | 69 | 12 | 80 | 90 | 11 | 97 |
| Methamphetamine | 46 | 16 | 50 | 64 | 7.4 | 75 | 87 | 3.5 | 94 |
| Phencyclidine | 27 | 26 | 30 | 64 | 9.6 | 73 | 86 | 5.2 | 91 |
| Phentermine | 53 | 9.2 | 58 | 78 | 6.6 | 91 | 95 | 2.9 | 101 |
| Phenylpropanolamine | 58 | 21 | 62 | 80 | 9.3 | 95 | 85 | 5.0 | 94 |
| Pseudoephedrine | 49 | 20 | 53 | 73 | 7.0 | 85 | 95 | 3.3 | 101 |

(1) Backup Data Report for NIOSH 9109 [4]. Area of each sample was 100 cm².

(2) Wall was an existing standard gypsum board wall painted with a latex based paint. Painted surface was at least one year old. There were six replicates for each solvent tested.

(3) Water was deionized water (ASTM type II). Note low recovery and high %RSD.

(4) For the serial wipe study, each 100-cm² area was wiped again with a fresh pre-wetted gauze wipe and the amount recovered was determined separately. In practice, a second (serial) wipe is included with the first gauze wipe; both gauze wipes constitute a single sample. The percent recoveries shown in the column represent the sum of the amounts recovered in both the first and second wipes.

(5) Each pre-measured area was spiked with 3 µg of each analyte in methanol and the methanol allowed to dry for several minutes prior to wipe sampling.

Table 9b. Recovery of methamphetamine from various surfaces with various solvents; one wipe compared with the sum of two wipes⁽¹⁾

| Surface Material ⁽³⁾ | Replicates | Isopropanol | | | Methanol | | |
|---------------------------------|------------------|-------------|------|---------------------------------|------------|------|---------------------------------|
| | | First Wipe | | Plus Second Wipe ⁽²⁾ | First Wipe | | Plus Second Wipe ⁽²⁾ |
| | | Percent | %RSD | Percent | Percent | %RSD | Percent |
| Enamel (lid of washing machine) | 4 ⁽⁴⁾ | 58 | 5.7 | 68 | 81 | 2.4 | 87 |
| Vinyl veneer on particle board | 4 ⁽⁵⁾ | 60 | 5.2 | 68 | 81 | 4.8 | 89 |
| Latex painted wall | 6 ⁽⁴⁾ | 64 | 7.4 | 75 | 87 | 3.5 | 94 |
| Refrigerator door | 2 ⁽⁵⁾ | 65 | 2.9 | 76 | 91 | 4.0 | 92 |
| Varnished hardwood panel | 2 ⁽⁶⁾ | 72 | 5.4 | 76 | 82 | 3.7 | 86 |
| Formica [®] countertop | 4 ⁽⁵⁾ | 75 | 4.9 | 82 | 87 | 3.8 | 91 |

(1) Backup Data Report for NIOSH 9109 [4]. Area of each sample was 100 cm².

(2) For the serial wipe study, each 100-cm² area was wiped again with a fresh pre-wetted gauze wipe and the amount recovered was determined separately. In practice, a second (serial) wipe is included with the first gauze wipe; both gauze wipes constitute a single sample. The percent recoveries shown in the column represent the sum of the amounts recovered in both the first and second wipes.

(3) The refrigerator door and the washing machine lid were from used appliances. The vinyl-veneered particle board (a book shelf), the Formica[®] countertop, and the varnished hardwood paneling were all purchased new. All surfaces of used and new materials were pre-cleaned with multiple rinses of methanol prior to spiking. Each pre-measured 100-cm² square was spiked with 3 µg methamphetamine.

(4) Samples were taken using the side-to-side and then top-to-bottom wiping technique.

(5) Half of the samples were wiped using the side-to-side wiping technique and half were wiped using the concentric squares wiping technique. There were no significant differences in recoveries. Percent recoveries and %RSDs are for both techniques combined.

(6) Samples were taken each time using only top-to-bottom wiping with the grain of the wood in an "N" pattern.

TABLE 10. Gas chromatographic retention times for heptafluorobutryl and trimethylsilyl derivatives of selected drugs of abuse, precursors, and potential adulterants⁽¹⁾

| GC Peak No. | Compound | Derivative Form ⁽²⁾ | Notes ⁽³⁾ | Retention Time Minutes ⁽⁴⁾ | Relative Retention Time | | Ions (Significant <i>m/z</i>) ⁽⁷⁾ | | |
|-------------|--|--------------------------------|----------------------|---------------------------------------|-------------------------|--------|---|-------------------|-------------------|
| | | | | | (5) | (6) | 1' | 2' ⁽⁷⁾ | 3' ⁽⁷⁾ |
| 1 | Acetaminophen ⁽⁸⁾ | N,N'- bis-TMS- | Pri.deriv. | 12.30 | 0.9594 | 1.2374 | 206 | 280 [90] | 295 [70] |
| 2 | Acetaminophen ⁽⁸⁾ | N-HFB-N'-TMS- | Minor peak | 10.37 | 0.8089 | 1.0433 | 330 | 404 [80] | 419 [30] |
| 3 | Aminorex | N,N'- bis-HFB- | Major peak | 14.12 | 1.1014 | 1.4205 | 385 | 342 [30] | 169 [40] |
| 4 | Aminorex | N-HFB-N'-TMS- | Major peak | 16.59 | 1.2941 | 1.6690 | 261 | 146 [48] | 128 [45] |
| 5 | Amphetamine | N-HFB- | Pri.deriv. | 8.54 | 0.6661 | 0.8592 | 240 | 118 [70] | 169 [20] |
| 6 | Amphetamine | N-HFB-N-TMS- | OS artifact | 9.21 | 0.7184 | 0.9266 | 312 | 91 [50] | 313 [10] |
| 7 | Amphetamine-D ₃ , ring labeled (I\$) ⁽⁹⁾ | N-HFB- | Pri.deriv. | 8.47 | 0.6607 | 0.8521 | 240 | 123 [85] | 96 [55] |
| 8 | Amphetamine-D ₃ , ring labeled (I\$) ⁽⁹⁾ | N-HFB-N-TMS- | OS artifact | 9.17 | 0.7153 | 0.9225 | 312 | 96 [45] | 73 [95] |
| 9 | Amphetamine-D ₆ (I\$) ⁽⁹⁾ | N-HFB- | Pri.deriv. | 8.45 | 0.6591 | 0.8501 | 244 | 123 [70] | 93 [45] |
| 10 | Amphetamine-D ₆ (I\$) ⁽⁹⁾ | N-HFB-N-TMS- | OS artifact | 9.14 | 0.7129 | 0.9195 | 316 | 93 [40] | 73 [75] |
| 11 | Amphetamine-D ₈ (I\$) ⁽⁹⁾ | N-HFB- | Pri.deriv. | 8.46 | 0.6599 | 0.8511 | 243 | 126 [75] | 96 [40] |
| 12 | Amphetamine-D ₈ (I\$) ⁽⁹⁾ | N-HFB-N-TMS- | OS artifact | 9.16 | 0.7145 | 0.9215 | 315 | 96 [25] | 73 [55] |
| 13 | Amphetamine-D ₁₁ (I\$) ⁽⁹⁾ | N-HFB- | Pri.deriv. | 8.46 | 0.6599 | 0.8511 | 244 | 128 [70] | 98 [45] |
| 14 | Amphetamine-D ₁₁ (I\$) ⁽⁹⁾ | N-HFB-N-TMS- | OS artifact | 9.14 | 0.7129 | 0.9195 | 316 | 98 [60] | 73 [70] |
| 15 | Atropine ⁽⁸⁾ | O-TMS- | Pri.deriv. | 18.86 | 1.4711 | 1.8974 | 124 | 361 [9] | 82 [17] |
| 16 | BDB | N-HFB- | Pri.deriv. | 13.35 | 1.0413 | 1.3431 | 135 | 176 [50] | 254 [12] |
| 17 | BDB | N-HFB-N-TMS- | OS artifact | 13.65 | 1.0647 | 1.3732 | 326 | 135 [60] | 73 [90] |
| 18 | Benzoyl ecgonine | O-TMS- | | 19.18 | 1.4961 | 1.9296 | 82 | 240 [45] | 361 [25] |
| 19 | Benzyl piperazine ⁽¹⁰⁾ ("Legal XTC") | N-HFB- | Pri.deriv. | 13.73 | 1.0710 | 1.3813 | 91 | 372 [30] | 281 [30] |
| 20 | 4-Bromo-2,5-DMPEA ⁽¹¹⁾ (Nexus) | N-HFB- | Pri.deriv. | 15.79 | 1.2317 | 1.5885 | 242 | 244 [98] | 229 [75] |
| 21 | 4-Bromo-2,5-DMPEA ⁽¹¹⁾ (Nexus) | N-HFB-N-TMS- | OS artifact | 16.22 | 1.2652 | 1.6318 | 229 | 231 [98] | 298 [85] |
| 22 | Bupropion (Wellbutrin [®] , Zyban [®]) | parent | | 12.15 | 0.9477 | 1.2223 | 44 | 100 [45] | 111 [20] |
| 23 | Caffeine ⁽⁸⁾ | parent | | 14.89 | 1.1615 | 1.4980 | 194 | 109 [45] | 67 [45] |
| 24 | S-(-)-Cathinone (from Khat plant) | N-HFB- | Pri.deriv. | 10.21 | 0.7964 | 1.0272 | 105 | 77 [45] | 240 [15] |
| 25 | S-(-)-Cathinone (from Khat plant) | N-HFB-N-TMS- | OS artifact | 10.89 | 0.8495 | 1.0956 | 105 | 312 [68] | 77 [55] |
| 26 | Chlorpheniramine ⁽⁸⁾ | parent | | 16.74 | 1.3058 | 1.6841 | 203 | 205 [32] | 167 [22] |
| 27 | Cocaine | parent | | 18.65 | 1.4548 | 1.8763 | 82 | 182 [90] | 303 [20] |
| 28 | Codeine | O-HFB- | Minor peak | 19.59 | 1.5281 | 1.9708 | 282 | 283 [20] | |
| 29 | Codeine | O-TMS- | Pri.deriv. | 20.72 | 1.6162 | 2.0845 | 371 | 343 [25] | 234 [55] |
| 30 | Dextromethorphan ⁽⁸⁾ | parent | | 18.10 | 1.4119 | 1.8209 | 271 | 270 [62] | 214 [40] |
| 31 | Diazepam (Valium [®] etc.) | parent | | 20.80 | 1.6225 | 2.0926 | 256 | 283 [90] | 284 [75] |
| 32 | Dibromooctafluorobiphenyl (I\$) ⁽⁹⁾ | parent | | 12.82 | 1.0000 | 1.2897 | 296 | 456 [100] | 454 [50] |
| 33 | N,N-Dimethyltryptamine (DMT) | N-HFB- | Pri.deriv. | 13.00 | 1.0140 | 1.3078 | 58 | 129 [15] | 42 [15] |
| 34 | N,N-Dimethyltryptamine (DMT) | N-TMS- | Minor peak | 15.02 | 1.1716 | 1.5111 | 58 | 73 [12] | 202 [10] |
| 35 | Ecgonine, methyl ester | O-TMS- | | 11.72 | 0.9142 | 1.1791 | 82 | 96 [75] | 83 [75] |
| 36 | Ephedrine | N-HFB-O-TMS- | Pri.deriv. | 11.40 | 0.8892 | 1.1469 | 179 | 254 [17] | 327 [10] |
| 37 | 1S,2R(+)-Ephedrine-D ₃ (I\$) ⁽⁹⁾ | N-HFB-O-TMS- | Pri.deriv. | 11.36 | 0.8861 | 1.1429 | 179 | 257 [20] | 330 [10] |
| 38 | N-Ethyl amphetamine | N-HFB- | Pri.deriv. | 10.33 | 0.8058 | 1.0392 | 268 | 240 [35] | 118 [15] |
| 39 | Fenfluramine ⁽⁸⁾ | N-HFB- | Pri.deriv. | 10.12 | 0.7894 | 1.0181 | 268 | 240 [35] | 159 [22] |
| 40 | Fenfluramine-D ₁₀ (I\$) ⁽⁹⁾ | N-HFB- | Pri.deriv. | 10.01 | 0.7808 | 1.0070 | 277 | 245 [35] | 160 [15] |

Table 10 continued

TABLE 10 (continued). Gas chromatographic retention times for heptafluorobutyryl and trimethylsilyl derivatives of selected drugs of abuse, precursors, and potential adulterants⁽¹⁾

| GC Peak No. | Compound | Derivative Form ⁽²⁾ | Notes ⁽³⁾ | Retention Time Minutes ⁽⁴⁾ | Relative Retention Time | | Ions (Significant <i>m/z</i>) ⁽⁷⁾ | | |
|-------------|--|--------------------------------|----------------------|---------------------------------------|-------------------------|--------|---|-------------------|-------------------|
| | | | | | (5) | (6) | 1' | 2' ⁽⁷⁾ | 3' ⁽⁷⁾ |
| 41 | Fentanyl (Sublimaze® etc.) | parent | | 22.97 | 1.7917 | 2.3109 | 245 | 146 [60] | 189 [33] |
| 42 | Flunitrazepam (Rohypnol®, roofies) ⁽¹⁰⁾ | parent | | 22.20 | 1.7317 | 2.2334 | 312 | 285 [95] | 286 [90] |
| 43 | Hydrocodone (Lortab® etc.) | HFB- | Minor peak | 19.47 | 1.5187 | 1.9588 | 495 | 438 [50] | 298 [40] |
| 44 | Hydrocodone (Lortab® etc.) | TMS- | Minor peak | 20.82 | 1.6240 | 2.0946 | 371 | 356 [50] | 234 [55] |
| 45 | Hydrocodone (Lortab® etc.) | parent | Pri.deriv. | 20.93 | 1.6326 | 2.1056 | 299 | 242 [50] | 243 [35] |
| 46 | Hydromorphone (Dilaudid®) | O-HFB-O'-TMS- | Minor peak | 19.85 | 1.5484 | 1.9970 | 308 | 267 [92] | 358 [75] |
| 47 | Hydromorphone (Dilaudid®) | O,O'-bis-TMS- | Minor peak | 20.98 | 1.6365 | 2.1107 | 414 | 429 [100] | 234 [75] |
| 48 | Hydromorphone (Dilaudid®) | O-TMS- | Pri.deriv. | 21.21 | 1.6544 | 2.1338 | 357 | 300 [55] | 342 [28] |
| 49 | Ketamine ("special K") ⁽⁸⁾⁽¹⁰⁾ | parent | Major peak | 15.24 | 1.1888 | 1.5332 | 180 | 182 [32] | 209 [22] |
| 50 | Lidocaine ⁽⁸⁾ | N-TMS- | Major peak | 13.69 | 1.0679 | 1.3773 | 86 | 220 [75] | 73 [45] |
| 51 | Lidocaine ⁽⁸⁾ | parent | Major peak | 15.28 | 1.1919 | 1.5372 | 86 | 58 [10] | 91 [5] |
| 52 | LSD (MW-519, scanned only to 470) | HFB- | Pri.deriv. | 24.61 | 1.9197 | 2.4759 | 417 | 221 [95] | 418 [45] |
| 53 | MBDB | N-TMS- | Minor peak | 14.30 | 1.1154 | 1.4386 | 144 | 73 [50] | 135 [15] |
| 54 | MBDB | N-HFB- | Pri.deriv. | 14.44 | 1.1264 | 1.4527 | 268 | 176 [75] | 210 [50] |
| 55 | MDA | N-HFB- | Pri.deriv. | 12.54 | 0.9782 | 1.2616 | 135 | 162 [55] | 240 [12] |
| 56 | MDA | N-HFB-N-TMS- | OS artifact | 12.88 | 1.0047 | 1.2958 | 312 | 73 [58] | 135 [48] |
| 57 | MDEA ⁽¹⁰⁾ | N-HFB- | Pri.deriv. | 14.19 | 1.1069 | 1.4276 | 268 | 162 [60] | 240 [50] |
| 58 | MDEA-D6 (I\$) ⁽⁹⁾ | N-HFB- | Pri.deriv. | 14.13 | 1.1022 | 1.4215 | 274 | 165 [46] | 244 [35] |
| 59 | MDMA ⁽¹⁰⁾ | N-HFB- | Pri.deriv. | 13.81 | 1.0772 | 1.3893 | 254 | 162 [80] | 135 [45] |
| 60 | Meperidine (Demerol® etc.) | parent | | 13.97 | 1.0897 | 1.4054 | 247 | 246 [55] | 218 [50] |
| 61 | Mephentermine | N-HFB- | Pri.deriv. | 10.38 | 0.8097 | 1.0443 | 268 | 210 [95] | |
| 62 | Mescaline | N-HFB- | Pri.deriv. | 14.68 | 1.1451 | 1.4769 | 181 | 194 [45] | 179 [30] |
| 63 | Mescaline | N-HFB-N-TMS- | OS artifact | 15.26 | 1.1903 | 1.5352 | 181 | 73 [35] | |
| 64 | Methamphetamine | N-HFB- | Pri.deriv. | 9.94 | 0.7754 | 1.0000 | 254 | 210 [35] | 118 [22] |
| 65 | Methamphetamine-D5 (I\$) ⁽⁹⁾ | N-HFB- | Pri.deriv. | 9.86 | 0.7691 | 0.9920 | 258 | 213 [30] | 92 [20] |
| 66 | Methamphetamine-D9 (I\$) ⁽⁹⁾ | N-HFB- | Pri.deriv. | 9.84 | 0.7676 | 0.9899 | 261 | 213 [30] | 123 [18] |
| 67 | Methamphetamine-D11 (I\$) ⁽⁹⁾ | N-HFB- | Pri.deriv. | 9.84 | 0.7676 | 0.9899 | 260 | 213 [25] | 126 [20] |
| 68 | Methamphetamine-D14 (I\$) ⁽⁹⁾ | N-HFB- | Pri.deriv. | 9.86 | 0.7691 | 0.9920 | 261 | 213 [30] | 128 [20] |
| 69 | Methaqualone | parent | | 18.31 | 1.4282 | 1.8421 | 235 | 250 [30] | 233 [28] |
| 70 | S-(-)-Methcathinone ("Cat") | N-HFB- | Pri.deriv. | 10.55 | 0.8229 | 1.0614 | 254 | 210 [35] | 105 [100] |
| 71 | 4-Methoxyamphetamine | N-HFB- | Pri.deriv. | 11.40 | 0.8892 | 1.1469 | 121 | 148 [40] | 240 [10] |
| 72 | 4-Methoxyamphetamine | N-HFB-N-TMS- | OS artifact | 11.87 | 0.9259 | 1.1942 | 312 | 121 [100] | 73 [100] |
| 73 | cis-(±)-4-Methylaminorex ("U4Euh") | N,N'-bis-HFB- | Minor peak | 13.78 | 1.0749 | 1.3863 | 399 | 169 [70] | 160 [75] |
| 74 | cis-(±)-4-Methylaminorex ("U4Euh") | N-HFB-N'-TMS- | Pri.deriv. | 16.78 | 1.3089 | 1.6881 | 275 | 160 [60] | 117 [30] |
| 75 | (-)-N-Methylephedrine ⁽¹¹⁾ | O-TMS- | Pri.deriv. | 9.66 | 0.7535 | 0.9718 | 72 | 73 [13] | 163 [5] |
| 76 | (+)-N-Methylephedrine ⁽¹¹⁾ | O-TMS- | Pri.deriv. | 9.71 | 0.7574 | 0.9769 | 72 | 73 [13] | 163 [5] |
| 77 | N-Methylphenethylamine (I\$) ⁽⁹⁾ | N-HFB- | Pri.deriv. | 9.54 | 0.7441 | 0.9598 | 240 | 104 [100] | 169 [40] |
| 78 | Methylphenidate (Ritalin®) | N-HFB- | Pri.deriv. | 15.38 | 1.1997 | 1.5473 | 280 | 281 [10] | |

Table 10 continued

TABLE 10 (continued). Gas chromatographic retention times for heptafluorobutyryl and trimethylsilyl derivatives of selected drugs of abuse, precursors, and potential adulterants⁽¹⁾

| GC Peak No. | Compound | Derivative Form ⁽²⁾ | Notes ⁽³⁾ | Retention Time Minutes ⁽⁴⁾ | Relative Retention | | | | |
|-------------|--|--------------------------------|----------------------|---------------------------------------|--------------------|--------|---|-------------------|-------------------|
| | | | | | Time | | Ions (Significant <i>m/z</i>) ⁽⁷⁾ | | |
| | | | | | (5) | (6) | 1' | 2' ⁽⁷⁾ | 3' ⁽⁷⁾ |
| 79 | N-Methyl pseudoephedrine ⁽¹²⁾ | O-TMS- | Pri.deriv. | 9.66 | 0.7535 | 0.9718 | 72 | 73 [13] | 163 [5] |
| 80 | Morphine | O-HFB-O'-TMS- | Minor peak | 19.97 | 1.5577 | 2.0091 | 340 | 324 [28] | 341 [25] |
| 81 | Morphine | O,O'-bis-TMS- | Pri.deriv. | 21.08 | 1.6443 | 2.1207 | 429 | 414 [50] | 401 [35] |
| 82 | Nicotine | parent | | 8.86 | 0.6911 | 0.8913 | 84 | 133 [35] | 162 [18] |
| 83 | Norpseudoephedrine (Cathine) | N-HFB-O-TMS- | Pri.deriv. | 10.39 | 0.8105 | 1.0453 | 179 | 180 [18] | 240 [18] |
| 84 | Norpseudoephedrine (Cathine) | N-HFB-N,O-bis-TMS- | OS artifact | 11.26 | 0.8783 | 1.1328 | 179 | 180 [18] | 312 [10] |
| 85 | Oxycodone (OxyContin [®]) | TMS- | Pri.deriv. | 21.66 | 1.6895 | 2.1791 | 387 | 388 [30] | 372 [30] |
| 86 | Phencyclidine (PCP) | parent | Major peak | 15.62 | 1.2184 | 1.5714 | 200 | 242 [35] | 243 [25] |
| 87 | Phencyclidine (PCP) | N-HFB-dehydro- | Artifact | 19.85 | 1.5484 | 1.9970 | 91 | 159 [60] | 280 [10] |
| 88 | Phencyclidine-D5 (I\$) ⁽⁹⁾ | parent | Major peak | 15.59 | 1.2161 | 1.5684 | 205 | 96 [42] | 246 [25] |
| 89 | Phencyclidine-D5 (I\$) ⁽⁹⁾ | N-HFB-dehydro- | Artifact | 19.83 | 1.5468 | 1.9950 | 96 | 164 [65] | 280 [10] |
| 90 | Phenethylamine ⁽⁸⁾ | N-HFB- | Pri.deriv. | 8.58 | 0.6693 | 0.8632 | 104 | 91 [60] | 169 [15] |
| 91 | Phenethylamine ⁽⁸⁾ | N-HFB-N-TMS- | Pri.deriv. | 9.51 | 0.7418 | 0.9567 | 298 | 105 [40] | 220 [10] |
| 92 | Phentermine ⁽⁸⁾ | N-HFB- | Pri.deriv. | 8.72 | 0.6802 | 0.8773 | 254 | 132 [12] | 214 [8] |
| 93 | 4-Phenyl-1-butylamine (I\$) ⁽⁹⁾ | N-HFB- | Pri.deriv. | 11.47 | 0.8947 | 1.1539 | 91 | 104 [25] | 176 [22] |
| 94 | Phenylephrine ⁽⁸⁾ | N-HFB-O,O'-bis-TMS- | Pri.deriv. | 13.94 | 1.0874 | 1.4024 | 267 | 268 [25] | 240 [12] |
| 95 | Phenylpropanolamine | N-HFB-O-TMS- | Pri.deriv. | 10.49 | 0.8183 | 1.0553 | 179 | 180 [18] | 240 [18] |
| 96 | Phenylpropanolamine | N-HFB-N,O-bis-TMS- | OS artifact | 11.01 | 0.8588 | 1.1076 | 179 | 180 [18] | 312 [10] |
| 97 | N-Propyl amphetamine (I\$) ⁽⁹⁾ | N-HFB- | Pri.deriv. | 11.05 | 0.8619 | 1.1117 | 282 | 240 [85] | 118 [20] |
| 98 | Pseudoephedrine | N-HFB-O-TMS- | Pri.deriv. | 11.68 | 0.9111 | 1.1751 | 179 | 254 [15] | 73 [75] |
| 99 | Theophylline ⁽⁸⁾ | parent | Major peak | 15.50 | 1.2090 | 1.5594 | 237 | 252 [57] | 223 [14] |
| 100 | Trifluoromethylphenyl piperazine ⁽¹⁰⁾ | N-HFB- | Pri.deriv. | 13.76 | 1.0733 | 1.3843 | 200 | 229 [70] | 172 [73] |

- (1) Actual retention times may vary depending on individual GC column and GC conditions. Gas chromatographic and mass spectrometer conditions used as on p. 9109-1.
- (2) Derivative form. HFB = heptafluorobutyryl derivative. TMS = trimethylsilyl derivative. N- = attachment to nitrogen atom. O- = attachment to oxygen atom. Not all forms are presented. Trifluoroacetyl derivatives are not presented. Underivatized compounds are identified as a "parent" compound. Parent compounds that have poor chromatographic peak shapes under the conditions used are not presented. Spectra for the derivatives are given in the Backup Data Report (Appendix-II) [4].
- (3) Major and minor peaks are identified where two or more forms are possible. In some cases two major peaks may exist. Pri.deriv. = Primary derivative, a major peak. The major peak or the primary derivative should be used for quantitation. OS artifact = Oversilylation artifact [14]. Oversilylation artifacts occur where a primary amine is substituted with both a heptafluorobutyryl and a trimethylsilyl group. Under the specified conditions of extraction and derivatization these remain as minor components and are of little concern.
- (4) Retention times are not the same as in Table 10 or Figures 1 and 2 in this method since these data were obtained on a different instrument. Relative retention times should be approximately the same.
- (5) Retention time relative to 4,4'-dibromooctafluorobiphenyl.
- (6) Retention time relative to the heptafluorobutyryl derivative of methamphetamine.
- (7) Significant ions that can be used for quantification and qualitative identification are given. The base peaks are not necessarily included, especially if they are low mass (<100 AMU). Numbers in brackets indicate the approximate relative abundance of the secondary (2') and tertiary (3') ions relative to the primary (1') ion and not necessarily to the base peak of each mass spectrum. Relative abundance varies with different tuning criteria and cleanliness of the mass spectrometer source. The 1' or 2' ions are recommended for quantification. All ions are selected as much as possible above *m/z* 100 to avoid interference from low mass co-eluting interferences. The 2' and 3' ions are selected as much as possible for nearness to the primary ion to minimize false negatives from skewing of spectra as the mass spectrometer source becomes contaminated with use. Ubiquitous ions (e.g., *m/z* 73, 91, and 169) are avoided as much as possible.
- (8) Intentional or unintentional adulterants. For example, phentermine may be added to MDMA and caffeine added to methamphetamine intentionally. Chlorpheniramine is an unintentional adulterant when pseudoephedrine containing chlorpheniramine is used as a methamphetamine precursor.
- (9) (I\$) = Internal standard. The best results are obtained using internal standards that are deuterated analogs of the target analyte, or those that are chemically and structurally similar to the target analytes.
- (10) Typical "club drugs" (piperazine analogs as ecstasy substitutes, ketamine and flunitrazepam as predatory drugs).
- (11) 4-Bromo-2,5-DMPEA = 4-Bromo-2,5-dimethoxyphenethylamine (Nexus).
- (12) Presence of (+)-norephedrine, N-methylpseudoephedrine and/or N-methylephedrine in pseudoephedrine or ephedrine indicates extracts of Ephedra spp. as source of methamphetamine precursor. Presence of amphetamine and N,N-dimethylamphetamine in methamphetamine final product also suggests the same source [22, 23, 24].

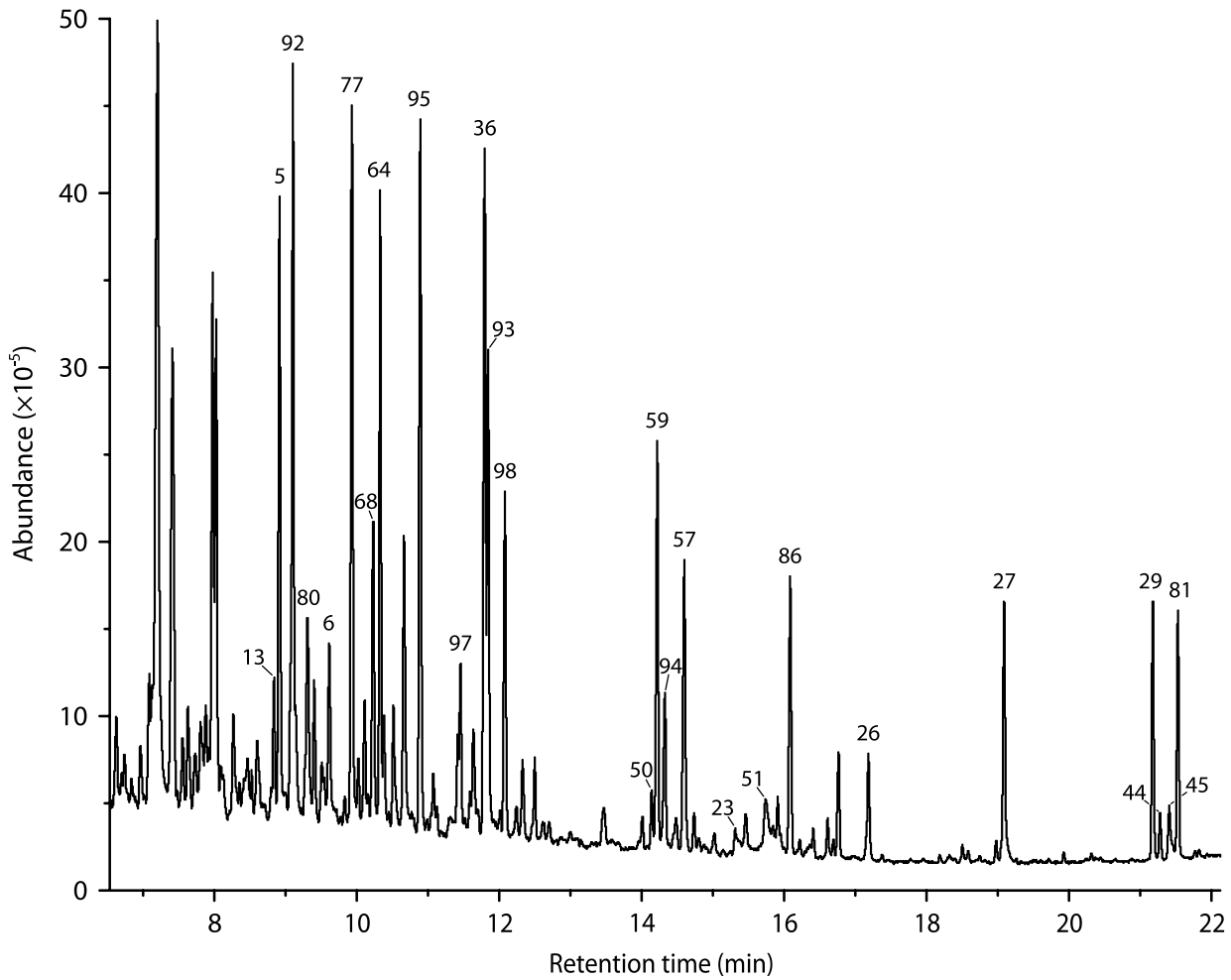

Figure 1. Typical chromatogram of mixed heptafluorobutyryl and trimethylsilyl derivatives by GC-MS in scan mode (time in minutes)

GC Peak Identification: See Table 10 for identification of numbered GC peaks. (But note that retention times in Table 10 do not correspond to those in Figure 1 because a different U.S. Pharmacopeia (USP) G27 column and instrument was used.)

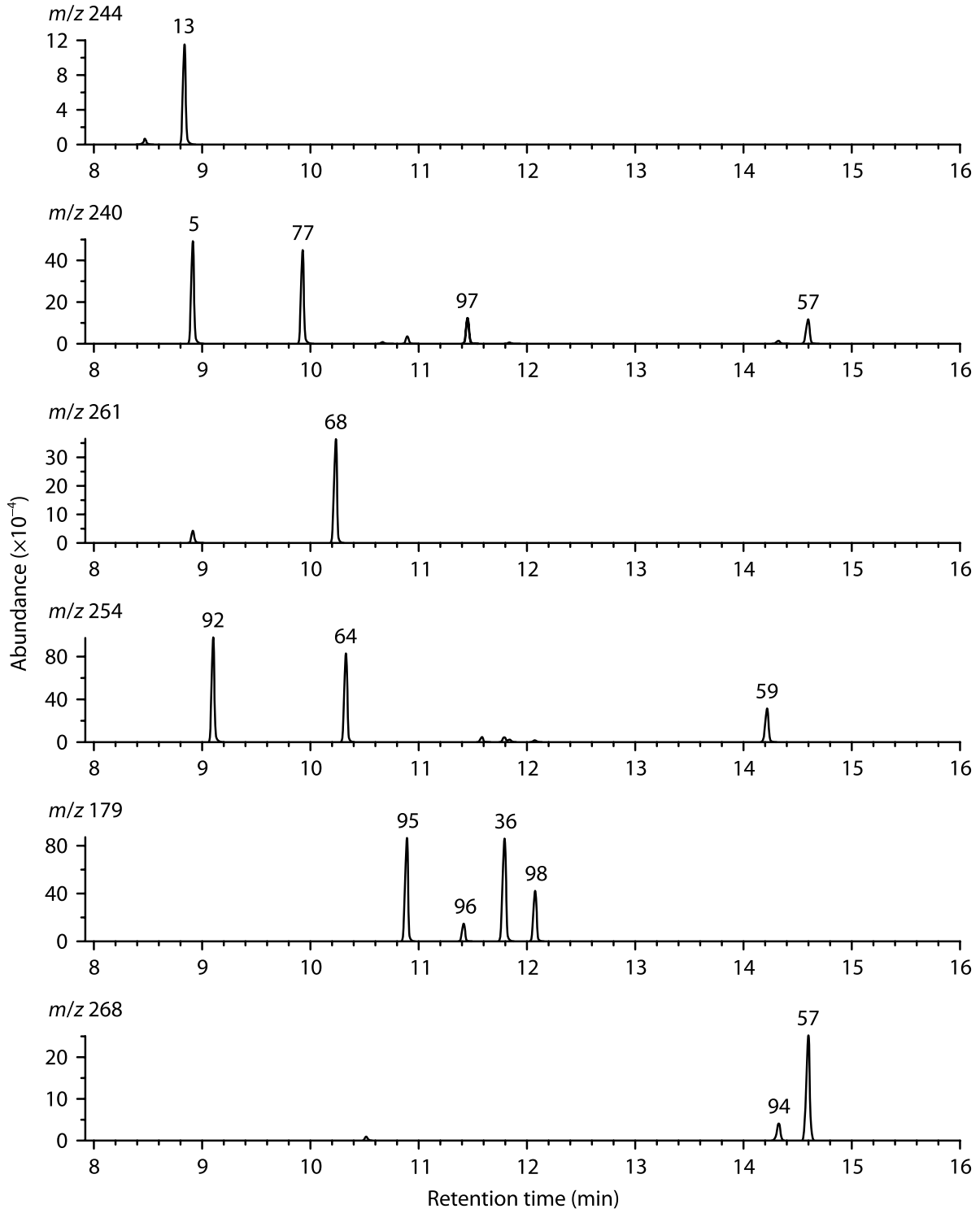

Figure 2. Typical extracted ion chromatograms (EIC) of mixed heptafluorobutyryl and trimethylsilyl derivatives by GC-MS in scan mode (time in minutes)

GC Peak Identification: See Table 10 for identification of numbered GC peaks. (But note that retention times in Table 10 do not correspond to those in Figure 1 because a different U.S. Pharmacopeia (USP) G27 column and instrument was used.)

APPENDIX:**A. REAGENTS and SOLUTIONS:**

1. 4,4'-Dibromooctafluorobiphenyl is optional. It is useful for monitoring instrument tuning and autosampler performance.
2. Primary amines form Schiff bases and enamines with ketones and aldehydes. These may in turn form derivatives with the acylating reagents. The use of acetone must strictly be avoided prior to the analytes being derivatized. Glassware and equipment rinsed with acetone must be thoroughly dried. Toluene should be avoided for making up standard solutions because it usually contains benzaldehyde, an oxidation product of toluene. Condensation products have been observed between primary amines and benzaldehyde. The only solvents recommended for the preparation of stock solutions and dilutions thereof are methanol (preferably) and isopropanol.

B. EQUIPMENT:

1. Wipe media: Besides cotton gauze, 4"X4" (10 cm x 10 cm) 4-ply MIRASORB® (Johnson and Johnson), and 4"X4" (10 cm x 10 cm) AlphaWipe® (TX1004, Texwipe Corp) were acceptable wipe media and can be used in the absence of cotton gauze. MIRASORB®, a non-woven cotton/polyester blend, is discontinued but counterparts exist that claim to be of identical construction and fiber composition. AlphaWipe® is a hydrophilic, highly adsorbent, tightly knitted continuous filament polyester wipe. Precision and accuracy data for MIRASORB® are given in the Backup Data Report [4].
2. Shipping containers: The 50-mL polypropylene centrifuge tubes with caps are preferred for one or two gauze wipes and are not as breakable as the 40-mL VOA vials. The 40-mL VOA vials are acceptable for single gauze wipes. Larger containers (glass with a PTFE lined cap) should be used for combining more than two gauze wipes into a single sample. The size of the container for two or more wipes should be approximately 25 mL per gauze wipe (e.g., a minimum size of 100-mL for up to four gauze wipe samples). There needs to be enough extra headspace in the shipping container to allow the desorption solution to cover the gauze wipes and to percolate freely through the wipe sample(s) during mixing.
3. Each regulatory agency having legal jurisdiction over the contaminated site may require different but specific off-site preparation and on-site sampling procedures. It is important to consult local regulatory agencies or departments of health having legal jurisdiction over contaminated sites to determine specific sampling, quality control, analyses, and reporting requirements.

C. SAMPLING:

1. Follow specific requirements of surface area to be wiped (usually 100 cm² or 1000 cm²) and action threshold (or maximum allowable residual level) set by the state or specified by the client. Uptake rates depend upon the wipe sampling method used, so the specific wipe technique used must be specified, and any deviations from the required wipe sampling requirements noted.
Note: To ensure that samples have not been tampered with, the use of custody seals and a chain-of-custody form is strongly recommended.
2. Prepare a rigid template from disposable cardstock or a sheet of PTFE having either a 10 cm x 10 cm or 32 cm x 32 cm square-cut hole. The template must be able to retain its shape during wiping to ensure that the areas wiped were either 100 cm² or 1000 cm². Secure the template(s) to the area(s) to be wiped (e.g., with tape along outside edge of template). If a single-use disposable template is not used, clean the template between samples to avoid cross-contamination, and provide the laboratory with a blank wipe of the cleaned template between samples to determine that no cross-contamination has occurred.
3. A template might not always be applicable, as in curved or odd-shaped areas such as around burners on stove tops or a fan blade. In such cases sample an area as close to either 100 cm² or 1000 cm² as feasible and provide the measurement to the regulatory agency and to the analytical laboratory for proper reporting. Tape can be used to delineate the sampling area.
4. It is recommended to provide extra wipe media from the same lot for required media blanks, field-equipment blanks, samples, and quality-control samples.

5. Gauze in sterile packaging is recommended to minimize the chance for cross-contamination, which can more easily occur with open bulk packaged cotton gauze.
6. To prevent contamination in the field, another alternative is to pre-wet and insert the gauze wipes into the sample containers off-site. This avoids any possibility of the bottle of methanol or isopropanol becoming contaminated on-site with methamphetamine (or other analytes). If the wipes were prepared off-site, then remove pre-wetted gauze wipe from sample container, opening only one sample container at a time. In either case, squeeze out and discard any excess solvent from the gauze wipe. Use fresh latex or nitrile gloves for each separate sample and blank. Do not use vinyl gloves due to the potential for leaching of phthalate plasticizers and contamination of the samples.
7. Wipe techniques
 - a. Concentric Squares Wiping Technique (particularly suitable for smooth and non-porous surfaces and described by OSHA [25]): Fold the pre-wetted gauze in half and then fold in half again. Using firm pressure wipe the area within the template. Start at one of the inside corners of the template and wipe in concentric squares, progressing toward the center. End with a scooping motion. Without allowing the gauze to touch any other surface, reverse the last fold so that the exposed side of the gauze is facing inward and using a fresh surface of the gauze, wipe the same area in the same manner as before. Roll or fold the gauze again and insert into the shipping container.
 - b. Side-to-side Wiping (or Blotting) Technique (particularly suitable for rough, porous, and/or soiled surfaces): Fold the pre-wetted gauze in half and then fold in half again. Using firm pressure wipe or blot the area within the template with at least five overlapping side-to-side horizontal passes (see NOTE) beginning at the top and progressing to the bottom in a "Z" pattern. End with a scooping motion. If blotting, blot at least five times on each horizontal pass (see NOTE). Without allowing the gauze to touch any other surface, reverse the last fold so that the exposed side of the gauze is facing inward. Using a fresh surface of the gauze, wipe or blot the area again with at least five overlapping top-to-bottom vertical passes beginning at the left side and progressing to the right in an "N" pattern. If blotting, blot at least five times on each vertical pass. Roll or fold the gauze again and insert into the shipping container. Blotting is suggested in areas so soiled or rough that the threads of the gauze media are continually snagged.

NOTE: On areas larger than 100 cm², more than five passes and blots will be needed.
 - c. Repeat or Serial Wiping: If isopropanol is used for wiping, a serial or repeat wipe sample of the same area with a fresh gauze wipe will improve sampling efficiency. (See recoveries for second wipe in Tables 9a and 9b.) For serial wiping, repeat the wiping procedure described above (APPENDIX 6a or 6b) with a fresh gauze wipe. Place the second gauze wipe into the same shipping container as the first gauze. The 50-mL polypropylene centrifuge tubes are large enough to contain up to two gauze wipes.

NOTE: If the area to be wiped remains substantially wet from the first gauze, the second gauze wipe might be used in the dry state to soak up the residual solvent from the first gauze wipe.
8. Composite sampling: Composite samples are allowed by some regulatory agencies. Their use for quantitative purposes may be subject to the permission and guidance of regulatory agencies. Refer to guidelines of regulatory agency for directions on composite sampling. A basic default guideline for composite sampling is as follows: Do not mix inconsistent samples, that is, areas wiped must be equal in area, sampled areas must have the same high or low probability of contamination, and sampled areas must relate to a specific target appliance or site and not to several appliances or incongruous sites combined.

NOTE: Composite samples cannot meet specific action-threshold requirements for discrete sampling locations. Nor do composite samples consisting of four wipes, for example, improve the sensitivity by decreasing the LOD four fold; instead it raises the LOD by a factor related to the extra volume of desorption solution that is required to desorb a larger number of wipes. The following example illustrates these two points. Assume that the action level was 0.1 µg/100 cm². If the analysis gave an LOD of 0.06 µg/sample for a single wipe or discrete sample covering an area of 100 cm², then the LOD for the analysis could be expressed as 0.06 µg/100

cm^2 , which is low enough to be able to determine whether any discrete sample is at or exceeds the action level. Now if a composite of four wipes was taken, each with an area of 100 cm^2 for a total area wiped of 400 cm^2 , the LOD for that composite sample is not $0.06 \mu\text{g}/400 \text{ cm}^2$ nor is it $0.015 \mu\text{g}/100 \text{ cm}^2$; it is actually several times larger than $0.06 \mu\text{g}/400 \text{ cm}^2$. First of all it increases relative to the ratio of the volume of desorption solution used to desorb the sample compared to that used for the calibration standards. Secondly it has nothing to do with the AREA that was wiped, because the LOD for the calibration curve is determined in terms of μg per sample, independent of the area. To explain the first point, assume approximately 90 mL was used (for ease in calculation) to desorb the four wipes and 30 mL (the normal amount for a single wipe) was used to desorb each calibration standard. The calculation of the LOD for the four composited samples would be $\mu\text{g}/\text{sample} \times (\text{desorption volume for 4 wipes})/(\text{desorption volume for the calibration standards})$, or $0.06 \mu\text{g}/\text{sample} \times (90 \text{ mL}/30 \text{ mL})$, or $0.18 \mu\text{g}/\text{sample}$ for the composited sample. Since the area wiped for the composite sample was 400 cm^2 , the LOD for that sample could be expressed as $0.18 \mu\text{g}/400 \text{ cm}^2$. Regarding the second point, this value, $0.18 \mu\text{g}/400 \text{ cm}^2$, cannot be construed or mathematically reduced to $0.045 \mu\text{g}/100 \text{ cm}^2$ because it cannot be known whether three of the four wipes were blank and the fourth wipe just under the value of $0.18 \mu\text{g}$. Hence, the effective LOD per individual wipe has to be regarded not only as $0.18 \mu\text{g}/400 \text{ cm}^2$ but also as $0.18 \mu\text{g}/100 \text{ cm}^2$ because any value determined for entire 400 cm^2 might have come from just one of those 100 cm^2 areas. Thus, for composite samples, the LOD must be expressed in terms of the entire area wiped and not extrapolated to some portion thereof. In this example, an LOD of $0.18 \mu\text{g}/100 \text{ cm}^2$ is above the action threshold of $0.1 \mu\text{g}/100 \text{ cm}^2$, meaning that this composite sample cannot satisfy the requirement that residual levels be below $0.1 \mu\text{g}/100 \text{ cm}^2$. It remains for the regulatory agency and not the laboratory to determine how to apply results for composite samples to the established action levels. The same consideration that is given above for the LOD applies to results that are greater than the LOD. To avoid confusion in reporting concentrations for composite samples, it is recommended that the sample concentration (in $\mu\text{g}/\text{sample}$, whatever the sample size) and the total area wiped (in cm^2) be reported separately. For example, a result of $0.4 \mu\text{g}/\text{sample}$ for a sample consisting of four separate wipes of 100 cm^2 each (for a total area wiped of 400 cm^2), is to be reported as $0.4 \mu\text{g}/400 \text{ cm}^2$ and not averaged to $0.1 \mu\text{g}/100 \text{ cm}^2$. This manner of reporting may be required by some regulatory agencies.

9. For quality assurance purposes, regulatory agencies may require duplicate samples to be taken in the field. If such is the case, an area contiguous with and adjacent to the first area, if possible, should be wiped as described under SAMPLING. Do not re-wipe the previously wiped area. This sample is a blind sample and should not be identifiable by the analytical laboratory as a duplicate of any other sample. These are distinct from the laboratory duplicates of a single sample described in step 14 of the method. Field duplicates are useful for evaluating the consistency of sampling technique, assuming uniformity of contamination on adjacent sampling sites. Laboratory duplicates are useful for evaluating consistency of sample preparation and instrumental analysis.

D. DESORPTION FROM MEDIA:

1. An internal standard spiking solution volume of $60 \mu\text{L}$ was selected for ease in scaling from $60 \mu\text{L}$ per 30 mL to $80 \mu\text{L}$ per 40 mL of desorption solution. In either case the rate of $2 \mu\text{L}$ internal standard spiking solution per mL desorption solution was used. However, any convenient volume of internal standard spiking solution (e.g., $50 \mu\text{L}$) that can be delivered reproducibly is acceptable. Whatever volume is chosen, there must be no variation in the volume of the internal standard spiking solution used in preparing each of the calibration standards. If spiking strategy A is used (see step D3 of APPENDIX), it is critical to know the exact volume of internal standard spiking solution that is applied to each sample (V_1), the media blanks (V_5), and the calibration standards (V_2), since these volumes are used for internal standard spiking solution volume corrections in step 19.
2. It is not necessary to know the exact volume of desorption solution added to each sample or the volume of residual wetting alcohol because differences in the volumes are normalized through the use of internal standards added prior to desorption.

3. Alternate strategy for spiking internal standards (spiking strategy B below): By using the exact same volume of internal standard spiking solution in all samples, blanks, QC samples, and calibration standards, regardless of the volume of desorption solution added or residual wetting alcohol, the volume corrections in step 19 (V_1/V_2 and V_5/V_2) drop out of the equation. However, the internal standard GC peak areas must still be measurable in samples where larger volumes of desorption solution are used (such as for composite samples). Because of the increased dilution of the internal standard in larger samples, this approach should be limited to desorption solution volumes of about 120 mL or less.

NOTE: There are two separate strategies for handling larger samples requiring larger volumes of desorption solvent. These are outlined below as strategies A and B.

| Number of Wipes | Size of Shipping Container (mL) | Volume of Internal Standard Spiking Solution (μL) | | Volume of Desorption Solution (mL) (Strategies A and B) |
|---------------------|---------------------------------|--|--|---|
| | | Strategy A | Strategy B | |
| 1 | 40 to 50 | 60 | 60 | 30 |
| 2 | 50 | 80 | 60 | 40 |
| 4 (e.g., composite) | 100 to 120 | 160 | 60 | 80 |
| | | Apply volume correction factors at step 19. | Do not apply volume correction factors at step 19. | |

With either strategy, if two gauze wipes were included in the samples, then use 40 mL of desorption solution. If four gauze wipes were included in the samples, then use 80 mL of desorption solution.

- In strategy A, the volume of internal standard spiking solution is kept at a constant ratio of 2 μL per mL of desorption solution added. This enables larger samples to be desorbed without diminishing the area of the GC peak for the internal standard. However, a volume correction factor (V_1/V_2) is needed in the final calculations in step 19. Therefore, the exact volume of internal standard added to each of the samples relative to that added to the calibration standards must be known.
 - In strategy B, the volume of internal standard spiking solution is kept constant for all samples and calibration standards, but need not be exactly 60 μL . This enables the final calculations to be made in step 19 without a volume correction factor. However, the area of the GC peak for the internal standard will vary with sample desorption volume and the internal standard must be concentrated enough to be measurable where larger volumes of desorption solution are used.
- E. SOLID PHASE EXTRACTION PROCEDURE:
The following SPE columns were investigated and found to work adequately for this method: BOND ELUT-CERTIFY[®] (200 mg/3mL); Clean Screen[®] (300 mg/3 mL) ; Oasis[®] MCX (60 mg/3 cc); or Speedisk[®] H2O-Philic SC-DVB. Two columns (Clean Screen[®] and BOND ELUT-CERTIFY[®]) are based upon a silica support. The other two (Oasis[®] and Speedisk[®]) are based upon an organic polymer support. The precision and accuracy data in Tables 7a and 7b were generated using the Waters Oasis[®] MCX 3cc/60 mg column.
- F. DERIVATIZATION:
There are unique advantages and disadvantages in using the mixed MSTFA + MBHFBA reagent. The disadvantages with some possible remedies are listed as follows.
- A few percent of trifluoroacetyl derivatives of secondary amines are formed (presumably from MSTFA) in competition to the intended heptafluorobutyl derivatives.

- a. Remedy #1: This artifact is eliminated by replacing MSTFA with MSHFBA (N-methyl-N-trimethylsilyl heptafluorobutyramide, Alltech Associates, Deerfield, IL). However, precision and accuracy were not evaluated for NIOSH 9109 using MSHFBA instead of MSTFA.
 - b. Remedy #2: If ephedrine compounds or compounds containing free hydroxyl groups are not to be analyzed, MSTFA might be omitted and MBHFBA used alone.
2. Use of the mixed reagent often results in over-silylation, the production of unintended silylation artifacts [14], particularly of amides. The primary over-silylation artifact with primary amines is the N-trimethylsilyl derivative of the N-acyl derivative. The GC peak area for this artifact can be significant; under certain circumstances it is nearly equal to that of the intended N-acyl derivative.
- a. Remedy #1: The presence of ammonium chloride from the SPE eluates seems to prevent or greatly reduce over-silylation of amides. These artifacts can be ignored when using the SPE columns with the 80:20:2 methylene chloride:isopropanol:ammonium hydroxide eluent.
 - b. Remedy #2: If ephedrine compounds or compounds containing free hydroxyl groups are not to be analyzed, silylating reagents (MSTFA or its alternate, MSHFBA) might be omitted and MBHFBA used alone.
3. The mass spectrometer may need more frequent cleaning to maintain sensitivity. This is offset by the shorter sample preparation time, especially for large numbers of samples.
4. When the fused silica capillary columns become exposed to the mixed silanization-acylation reagents, the column may become unsuitable for other types of samples.
5. The chromatograms are cluttered with silylation by-products making it difficult to detect low levels of unknown (non-target) compounds if a drug screen for unknown compounds is an objective. For this objective, the liquid-liquid extraction procedure of NIOSH 9106 [6] provides cleaner chromatograms with less interference from reagent by-products.
6. The advantages of the mixed MSTFA+ MBHFBA reagent, when used with SPE, are as follows:
- a. Faster preparation time (no heating in an oven, no cool-down time, no evaporation or neutralization of the reagents, and no reconstitution with solvent thereafter).
 - b. No heat or acid induced isomerization or dehydroxylation of the ephedrine or other hydroxyl containing compounds (e.g., ephedrine, norephedrine, pseudoephedrine, phenylephrine, etc.).
 - c. The method can be extended to easily hydrolyzed phenolic and polyhydroxy compounds of aryl-alkyl-amines (e.g., Albuterol, epinephrine and metabolites [15], metabolites of MDMA, and phenylephrine) because of the thermal stability of the trimethylsilyl ether groups on phenols and trimethylsilyl ester groups.
 - d. Hindered amines such as MDEA are derivatized more completely but still require an internal standard with structural similarity.

G. MEASUREMENT:

Recoveries for the laboratory control matrix spike samples (QC and QD) must meet the guidelines of the specific regulatory agency involved (80-120% is a reasonable target in the absence of specific guidance).

NOTE 1: The QC samples (QC and QD) in this method may be referred to in some guidance documents as matrix spike and matrix spike duplicate samples (MS/MSD) but serve the same purpose. Analyze and report field-equipment blanks as samples. Do not subtract their values from any other sample.

Recoveries of CCV standards must meet guidelines of regulatory agency (80-120% is a reasonable target in the absence of specific guidance). The CCV standards may be referred to in some guidance documents as 'QC samples' but such QCs are equivalent to liquid standards (not matrix spiked samples) and serve the same purpose of the CCVs in this method.

NOTE 2: With the GC/MS it is possible to achieve the lower limit of 0.05 µg or less per sample for methamphetamine in either the scan mode or SIM mode. The scan mode is essential where the identification of unknowns is an analytical objective. If lower limits of detection are desired or difficult to obtain in the scan mode, or for routine target compound only analyses, the instrument may be operated in the SIM mode.

H. MAKING DILUTIONS:

If the samples exceed the upper calibration range for the analysis, one of the following procedures may be used to estimate the high level concentrations.

1. Dilution procedure A (dilution of the derivatization mixture within a GC vial): Transfer an aliquot of the derivatization sample mixture from the GC vial to a clean low-volume GC vial and add acetonitrile, MSTFA, and MBHFBA. For example, for a 10:1 dilution transfer 20 μL of sample to a clean vial and add 120 μL of acetonitrile and 30 μL each of MSTFA and MBHFBA, for a total volume of 200 μL . For a 4:1 dilution, transfer 50 μL of sample to a clean vial and add 100 μL of acetonitrile and 25 μL each of MSTFA and MBHFBA, for a total volume of 200 μL . Cap the GC vial, mix by inversion a few times, and analyze diluted sample. Do not include the dilution factor in step 19 since the internal standard will be diluted along with the target analyte.

NOTE: For dilutions greater than 10, the internal standard may become too diluted to quantify. In such a case, use the following procedure B.

2. Dilution procedure B (dilution of the original sample desorbate): In this procedure, an aliquot of the original sample desorbate is diluted with a simulated blank solution and then transferred to a SPE column in step 8d. For example, for a 10:1 dilution, dilute 0.5 mL of sample desorbate solution from step 7f in a clean test tube containing 4.5 mL of a simulated blank solution, mix, and then transfer the entire contents to a pre-conditioned SPE column. For a 50:1 dilution, dilute 0.1 mL of sample desorbate solution from step 7f in a clean test tube containing 4.9 mL of a simulated blank solution, mix, and then transfer the entire contents to a pre-conditioned SPE column. Proceed thereafter to step 8d as normal. The simulated sample blank should be prepared identically to the sample needing dilution, using the same volumes of internal standard spiking solution and desorption solution that were used with the sample in the original desorption. For example, if the original sample was desorbed with 40 mL desorption solution with 80 μL of added internal standard spiking solution, then prepare the simulated blank in the same way. The volume of wetting alcohol is estimated (e.g., about 3 mL per 3"x3" 12-ply cotton gauze wipe). Include a dilution factor (V_3/V_4) in the calculations in step 19 (e.g., $V_3/V_4 = 5 \text{ mL}$ divided by the volume in mL of original desorbate diluted to 5 mL with solution from the simulated blank). The dilution factor in the above examples are 5 mL/0.5 mL or 10 for a 10:1 dilution and 5 mL/0.1 mL or 50 for a 50:1 dilution. Correct for differences in internal standard spiking solution volumes in step 19 (if applicable) using for V_1 the volume of internal standard spiking solution which was added to the original undiluted sample.

Caution: This dilution procedure gives quantitative results only if the residual volume of methanol (or isopropanol) used for wetting the sample wipes was exactly the same as the volume used in preparing the calibration standards (normally about 3 mL, see Table 6). Deviations of a few milliliters in residual wetting alcohol will not affect the results for undiluted samples but will amount to an error of a few percent in the final results of samples that are diluted.

The potential error due to differences in residual wetting solvent can be estimated for specific volumes of desorption solution and wetting alcohol. Assume the sample wipes and calibration standards are both desorbed in 30 mL of desorption solution and 3 mL of alcohol is added to the calibration standards. The potential error in volume (and final results) in the samples is approximately $\pm 3.03\%$ (inversely proportional) per mL difference in the residual alcohol in the samples (i.e. $\pm 1 \text{ mL}$ difference in 33 mL). For 40 mL of desorption solution and 4 mL of alcohol added to the calibration standards, the error is $\pm 2.27\%$ for every mL difference (i.e. $\pm 1 \text{ mL}$ difference in 44 mL). However, since the volume of residual wetting alcohol is not known and cannot be determined once the sample wipe has been desorbed, the actual error cannot be determined.

However, the maximum possible error can be calculated. Since the maximum amount of alcohol that a 3"x3" 12-ply (or 4"x4" 8-ply) cotton gauze can hold is about 6 mL when saturated (dripping wet), there can only be a deviation of plus or minus 3 mL from the 3 mL alcohol added to the calibration standards. Therefore, the maximum error in a result due to differences in the volume of residual alcohol in a cotton gauze sample compared to

the standards can only be three times the error for a 1 mL difference in volume. Since the error for ± 1 mL is $\pm 3.03\%$, the maximum error for ± 3 mL is three times larger, or $\pm 9.1\%$. In practice, the error will be less than this because it is unlikely that the gauze samples will be completely dry or completely saturated after squeezing out the excess alcohol and wiping a surface. The practical amount of alcohol that remains in the 3"x3" 12-ply (or 4"x4" 8-ply) cotton gauze wipes when the excess is squeezed out is between 1 and 2 mL. This translates into an error that is between +3% and +6% in the final results for diluted samples. Undiluted samples will not be affected. This error is within the overall accuracy for the method for methamphetamine.

3. Dilution procedure C (dilution of desorbates from dried samples): Dilution errors for over-range samples may be corrected by knowing the exact amount of residual alcohol in the samples. The volume (or weight) of residual solvent in each gauze wipe might be determined by the difference between a wet weight and dry weight. Better yet, the error might be eliminated for diluted samples by adding, after the samples are dried (without taking any weight), the same known volume of wetting alcohol that is added to the calibration standards (i.e. 3 mL). Thereafter, if any samples need dilution, there will be no dilution errors due to differences in residual alcohol, because all samples and standards will have the same volume of alcohol and total volume of desorption solution. However, air drying of the samples is not recommended because of the possible loss of methamphetamine due to its volatility when it is not in the salt form, which form cannot be assured in field samples. Also, manipulating the samples for weighing and drying might introduce contamination. Drying is not recommended as a procedure for analytes having a vapor pressure high enough to be lost in the process, or that tend to form azeotropes with alcohols, especially when the critical action levels for remedial cleanup are at the lower end of the method calibration range. Drying is not an option if the samples have already been desorbed.



BERYLLIUM in Surface Wipes by Fluorometry

9110

Be

MW: 9.0121

CAS: 7440-41-7

RTECS: DS1750000

METHOD: 9110, Issue 2

EVALUATION: FULL

Issue 1: 6 April 2007

Issue 2: 12 December 2015

OSHA: none for surfaces

MSHA: none for surfaces

DOE: 3 µg per 100 cm² (housekeeping), 0.2 µg per 100 cm² (equipment release) [1]

OTHER OELs: [2]

PROPERTIES: solid, d 1.85 g/mL, MP 1,278 °C, VP 0 kPa (0 mm Hg) @ 25 °C

SYNONYMS: beryllium metal, beryllia (BeO)

| SAMPLING | | MEASUREMENT | |
|--|--|-----------------------------------|--|
| SAMPLER: | WIPE (cellulosic or polyvinyl alcohol) | TECHNIQUE: | UV/VIS FLUOROMETRY |
| WIPE AREA: | 100 cm ² minimum | ANALYTE: | complex of hydroxybenzoquinoline sulfonate (HBQS) with beryllium |
| SHIPMENT: | routine | DISSOLUTION: | ammonium bifluoride (aqueous), 10 g/L |
| SAMPLE STABILITY: | stable | DETECTION SOLUTION: | contains 63.4 µmol/L HBQS, 2.5 mmol/L EDTA, and 50.8 mmol/L lysine monohydrochloride (optional); pH adjusted to 12.85 with 10 mol/L NaOH, as necessary |
| BLANKS: | 3 field blanks min. | DETECTOR: | excitation, 360 nm to 390 nm; emission, integrated between 470 and 480 nm (λ _{max} ≈ 475 nm) |
| ACCURACY | | CALIBRATION: | beryllium standard solutions |
| RANGE STUDIED: | 0.0001 to 6 µg per wipe [3,4] | RANGE: | (0.005 to 6) µg per wipe [3,4] |
| BIAS: | negligible [3,4] | ESTIMATED LOD: | 0.0001 µg per wipe |
| OVERALL PRECISION (S_{rT}): | 0.094 | PRECISION (S_r): | 0.021 at ≈0.2 µg per wipe, 0.076 at ≈1.5 µg per wipe, 0.052 at ≈3 µg per wipe |
| ACCURACY: | 18.9% | | |

APPLICABILITY: The working range of the method is 0.0005 µg to 6 µg for surface wipe samples. The analysis is for total beryllium and is not compound specific.

INTERFERENCES: Minor interference from iron can result if iron concentrations are high. Samples high in iron demonstrate a yellow or gold coloration. This interference can be minimized by allowing the solution to sit for at least two hours, during which time the solution clears, and then filtering the sample extract before use. An alternative method is to filter the solution (after 30 minutes of standing) through a hydrophilic filter of pore size of 0.2 µm or smaller.

OTHER METHODS: Method 7300 (hot plate digestion and inductively coupled plasma atomic emission spectrometry) is an alternative procedure for the determination of elemental beryllium [5], but with higher detection limits. ASTM method D7202 is a similar procedure to detect elemental beryllium by fluorescence [6].

REAGENTS:

1. Ammonium bifluoride.*
2. Ethylenediaminetetraacetic acid (EDTA), disodium salt, dihydrate.
3. 10-Hydroxybenzo[*h*]quinoline-7-sulfonate (HBQS) [5].
4. L-Lysine monohydrochloride
5. Sodium hydroxide.*
6. Water, deionized.
7. Dissolution solution:* aqueous ammonium bifluoride, 10 g/L (prepared by dissolving ammonium bifluoride in deionized water)
8. Detection solution:* 63.4 $\mu\text{mol/L}$ HBQS, 2.5 mmol/L EDTA, and 50.8 mmol/L lysine monohydrochloride; pH adjusted to 12.85 with 10 mol/L NaOH). An alternative preparation of dye solution without lysine (lysine-free) may be made by adding 1.104 g of EDTA and 64 μmoles of the 10-HBQS dye in 900 ml of water. After a clear solution is obtained, 114.5 ml of 2.5 N NaOH is added and mixed to obtain the final dye solution. The pH of the dye solution is 13.2. The lysine-free dye solution (commercially available) may be used for all analytical purposes and also provides superior detection limits.
9. Beryllium standard solution,* 1,000 mg/L (commercially available).
10. Beryllium-spiked media* (commercially available).

*See SPECIAL PRECAUTIONS.

EQUIPMENT:

1. Sampler: wipe, cellulosic, 47 mm diameter minimum.
NOTE: Polyvinylalcohol (PVA) media are also suitable for this method [7]
2. Template, disposable/reusable, 100 cm² minimum area.
3. Tape, masking
4. Ultraviolet/visible (UV/Vis) fluorometer, with excitation lamp ($\lambda = 380 \text{ nm}$) and time-integrating visible detector (400 nm to 700 nm, $\lambda_{\text{max}} \approx 475 \text{ nm}$) or optical filters for appropriate wavelengths (excitation of 360 nm to 390 nm; emission of $\approx 475 \text{ nm}$, with full width at half maximum of $\pm 5 \text{ nm}$).
5. Mechanical agitator, shaker, or rotator.
6. Hot block (for beryllium oxide extraction).
7. Fluorescence cuvettes, disposable, 10 mm diameter, transparent to UV/Vis radiation.
8. Centrifuge tubes, plastic, 15 mL
9. Syringe filters, hydrophilic polypropylene, 0.2 μm pore size, 25-mm diameter, in plastic housings.
NOTE: Polytetrafluoroethylene (PTFE) filters are unsuitable for this method
10. Pipettors, mechanical, of assorted sizes. Pipet tips, plastic, disposable, of assorted sizes.
11. Labware, plastic (e.g., beakers, flasks, graduated cylinders), of assorted sizes.
12. Tweezers, plastic or plastic-coated.
13. Laboratory wipes.
14. Personal protective wear (e.g., respirators, gloves, lab coats, safety eyewear), as needed

SPECIAL PRECAUTIONS: Wear appropriate personal protection during sampling activities and analysis. It is essential that suitable gloves, eye protection, laboratory coat, etc., be used when working with the chemicals. Perform sample preparation and analysis in a clean, well-ventilated area that is well removed from any possible beryllium contamination. Any area of skin affected by the dissolution or detection solutions must be immediately washed with plenty of water. Ammonium bifluoride will etch glass, so it is essential that all ammonium bifluoride solutions be contained in plastic labware. Avoid exposure by contact with skin or eyes, or by inhalation of vapor.

SAMPLING [8,9]:

1. Don a clean pair of gloves.
2. Demarcate the sampling area (100 cm² minimum) using a clean template or tape. If a template is used, tape the outside edges of the template to the surface to prevent its moving during sampling.
3. Wet a clean wipe with 0.2 mL of deionized water and wipe the surface to be sampled with firm pressure, using 3 to 4 vertical S-strokes. Fold the exposed side of the wipe in and wipe the area with 3 to 4 horizontal S-strokes. Fold the wipe once more and wipe the perimeter of the area.
4. Fold the wipe sample, exposed side in, and place into a labeled 15 mL plastic centrifuge tube.

SAMPLE PREPARATION:

5. Add 5 mL of the dissolution solution (ammonium bifluoride, 10 g/L) to each 15 mL centrifuge tube containing a wipe sample, and cap each tube.

6. Place each tube into a mechanical rotator, and rotate for at least 30 min.

NOTE: Rotator may also be substituted by a shaker or an agitator as long as the dissolution solution wets the wipe well. Sonication has also been shown to be effective. For dissolution of refractory materials such as high-fired beryllium oxide, agitation of the dissolution solution with the media must be replaced by heating to 85 °C for 60 minutes or more. Any standard dissolution process is particle-size dependent [10]. The two sources of BeO used to validate the method are described in the backup data report [11].

7. Filter each solution with a hydrophilic polypropylene syringe filter into a clean tube.

NOTE: This tube should be able to accept a cap so that the solution may be saved and used later for reanalysis if required.

8. Pipet 0.1 mL of each sample filtrate into cuvettes containing 1.9 mL of the detection solution. Cap and mix briefly.

NOTE: The above procedure is typically used to analyze a range of 0.05 µg to 6 µg of beryllium on the sampling media. Alternative ratios of dissolution solution and detection solution may be used for analyzing alternative ranges of beryllium concentration. To test a range of 0.005 µg to 0.4 µg of beryllium on the sampling media, 0.4 mL of the sample filtrate is added to 1.6 mL of the detection solution in the cuvettes. The lysine-free dye solution may also be used for obtaining even lower detection limits at a dilution ratio of 3x, where 1.33 mL of the dye solution is mixed with 0.67 mL of the filtered solution extracts (Table 3), and beryllium in the range of 0.0005 µg to 0.4 µg may be determined.

NOTE: If high iron or titanium concentration is suspected or is evident (owing to the appearance of suspended precipitate), allow the solution to settle and filter the solution using a hygroscopic syringe filter (e.g., polyethersulfone, or hydrophilic polypropylene).

NOTE: The stability of the detection and the dissolution solution is more than six months and of the mixed measurement solution comprising both is greater than 30 days. The solutions must be kept in sealed containers, and the detection and mixed solutions must be stored away from light.

NOTE: If the samples are suspected of having a contaminant that fluoresces and has excitation and emission spectra that overlap with that of the signal produced by the fluorescent dye bound to beryllium, then this contaminant needs to be removed. The presence of such a contaminant can be verified by subjecting the filtered sample to fluorescence excitation after the extraction step (without adding the fluorescent dye). If a fluorescence signal is detected, then that signal is ascribed to the presence of a fluorescent contaminant. To remove the contaminant, high-purity activated charcoal is added to the beryllium extraction solution (~10mg/mL) and the extraction procedure is carried out at elevated temperature (80 to 90 °C for at least 45 minutes). If the beryllium extraction procedure has already been performed, then after the addition of activated charcoal, the extraction process is repeated at the elevated temperature. The solution is filtered to remove the activated charcoal before adding this to the detection solution to make the measurement solution. Details of this process have been published [12,13].

CALIBRATION AND QUALITY CONTROL:

9. Calibrate the fluorometer with beryllium stock standard solutions. Prepare a calibration graph of fluorescence intensity vs. beryllium concentration (ng/mL) in the stock standard.

NOTE: To test a range of 0.05 µg to 6 µg of beryllium on the sampling media, beryllium stock standard solutions are made up using beryllium spectrometric standards diluted with the ammonium bifluoride dissolution solution. A recommended series of stock standard solutions is (800, 200, 40, 10, and 0) ng/mL. As with the samples, the stock standards are prepared for analysis by

adding 0.1 mL of beryllium stock standard into 1.9 mL of detection solution (20-fold dilution). Please see Table 1. Either of the two detection solutions may be used.

NOTE: To test a range of 0.005 µg to 0.4 µg of beryllium on the sampling media, a recommended series of stock standard solutions is (80, 20, 4, 1, and 0) ng/mL. These standards with lower beryllium concentration can be prepared by 10-fold dilution of the stock standards mentioned in the note above. As with the samples, these stock standards are prepared for analysis by adding 0.4 mL of beryllium stock standard into 1.6 mL of detection solution (5-fold dilution). Please see Table 2.

Either of the two detection solutions may be used.

NOTE: When using the lysine-free dye solution ONLY, a range can be tested of 0.0005 to 0.4 µg of beryllium on the media using a recommended series of stock solutions is (0, 0.15, 0.3, 0.6 and 2.4) ng/mL. These standards with lower beryllium concentration can be prepared by dilution of the stock standards mentioned in the note above. The standards are prepared for analysis by adding 0.67 mL of beryllium stock standard into 1.33 mL of detection solution (3-fold dilution). This dilution will result in 0, 0.05, 0.1, 0.2 and 0.8 ppb of beryllium in these standards; see Table 3. Cellulosic filters (47 mm in diameter) were spiked with a solution of beryllium acetate and analyzed in triplicate after extracting beryllium in 5 ml of 1% ABF solution at 85°C for 60 minutes and then mixed with lysine-free dye solution in a 3-fold dilution; these results are shown in Table 4. The difference in the average fluorescent signals from blanks and the 0 ppb standard were subtracted from the fluorescent readings of the spiked filters.

NOTE: If alternative ratios of dissolution solution and detection solution are used for sample preparation, then a similar ratio for calibration solutions is required.

10. Analyze a stock standard, a reagent blank, and a media blank at least once every 20 samples. Ensure that the concentration range of the stock standards spans the beryllium levels found in the samples.
11. Analyze one media spike and one quality control blind spike per 20 samples (minimum of three each per sample set) to insure that percent recovery is in control (e.g., 100 ± 15). Correct sample results for the average recovery if it differs significantly from 100%.

NOTE: If it is suspected that beryllium oxide may be present, then it is recommended to use beryllium oxide for media and blind spikes.

MEASUREMENT:

12. For each sample, obtain the fluorescence intensity at λ_{\max} or with optical filter for appropriate wavelength.
13. If the fluorescence response for any of the samples is above the range of responses for the stock standards, dilute the sample filtrate with dissolution solution, reanalyze, and apply the appropriate dilution factor (D) in subsequent calculations.

CALCULATIONS:

14. Obtain the solution concentration for each sample filtrate, C_s (ng/mL), and the average media blank, C_b (ng/mL) from the calibration graph.
15. Using the dissolution volumes (normally 5 mL) of sample, V_s (mL), and media blank, V_b (mL), calculate the concentration, C (µg/m²), of Be in the surface area sampled, A (cm²), while accounting for the dilution factor (D).

$$C = D \times (C_s V_s - C_b V_b) / (10 \times A) \text{ } \mu\text{g}/100 \text{ cm}^2$$

NOTE: Tables 1, 2 and 3 can be used for correlating the amount of beryllium in the sampling media with the concentrations of beryllium in solution. Table 1 is for testing media with 0.05 µg to 6 µg of beryllium at 20-fold dilution; Table 2 is for testing media with 0.005 µg to 0.4 µg of beryllium at 5-fold dilution; and Table 3 is for testing media with 0.0005 µg to 0.012 µg of beryllium at 3-fold dilution. Lysine-free dye solution may be used for any of these dilutions, but for 3x dilution, lysine-free dye solution must be used.

Table 1. Correlation of amount of Be in sampling media with Be concentration in stock standard and Be concentration as analyzed, assuming 0.1 mL of sample or stock standard is added to 1.9 mL of detection solution (20-fold dilution).

| Be concentration in stock standard (ng/mL) | Be concentration as analyzed (ng/mL) | Amount of Be in the media* (ng) |
|--|--------------------------------------|---------------------------------|
| 0 | 0 | 0 |
| 10 | 0.5 | 50 |
| 40 | 2 | 200 |
| 200 | 10 | 1000 |
| 800 | 40 | 4000 |

*Equals stock standard Be concentration (ng/mL) × volume (5 mL) of dissolution solution used to extract media.

Table 2. Correlation of amount of Be in sampling media with Be concentration in stock standard and Be concentration as analyzed, assuming 0.4 mL of sample or stock standard is added to 1.6 mL of detection solution (5-fold dilution).

| Be concentration in stock standard (ng/mL) | Be concentration as analyzed (ng/mL) | Amount of Be in the media* (ng) |
|--|--------------------------------------|---------------------------------|
| 0 | 0 | 0 |
| 1 | 0.2 | 5 |
| 4 | 1 | 25 |
| 20 | 4 | 100 |
| 80 | 16 | 400 |

*Equals stock standard Be concentration (ng/mL) × volume (5 mL) of dissolution solution used to extract media.

Table 3. Correlation of amount of Be in sampling media with Be concentration in stock standard and Be concentration as analyzed, assuming 0.67 mL of sample or stock standard is added to 1.33 mL of lysine-free dye solution (3-fold dilution).

| Be concentration in stock standard (ng/mL) | Be concentration as analyzed (ng/mL) | Amount of Be in the media* (ng) |
|--|--------------------------------------|---------------------------------|
| 0 | 0 | 0 |
| 0.15 | 0.05 | 0.75 |
| 0.3 | 0.1 | 1.5 |
| 0.6 | 0.2 | 3 |
| 2.4 | 0.8 | 12 |

*Equals stock standard Be concentration (ng/mL) × volume (5 mL) of dissolution solution used to extract media.

Table 4: Analysis of beryllium spiked cellulosic filters (47mm in diameter) using 3-fold dilution of the extraction solution with lysine-free dye solution. Beryllium concentration of calibration solutions after mixing with the dye solutions were 0, 0.05, 0.1, 0.2 and 0.8 ng/ml. Samples analyzed in triplicate, Averages and standard deviations are shown both in ppb in the solution and as μg on the filter.

| Nominal Be concentration on the spiked filter, μg | Be concentration measured in the mixture of dye and sample solution, ppb \pm Std Dev | Be concentration measured on the wipes, $\mu\text{g} \pm$ Std Dev |
|--|--|---|
| 0 | 0.0003 \pm 0.0057 | 0.0000 \pm 8.5E-5 |
| 0.0005 | 0.0375 \pm 0.0073 | 0.00056 \pm 11.0E-5 |
| 0.001 | 0.0735 \pm 0.0058 | 0.0011 \pm 8.7E-4 |
| 0.002 | 0.1262 \pm 0.0047 | 0.0019 \pm 7.11E-4 |
| 0.005 | 0.3396 \pm 0.0093 | 0.0051 \pm 1.39E-4 |
| 0.05 | 3.275 \pm 0.051 | 0.049 \pm 7.58E-4 |
| 0.48 | 32.29 \pm 0.293 | 0.484 \pm 4.40E-3 |

EVALUATION OF METHOD:

The method was evaluated [3,4,11,14] in accordance with published guidelines [15]. Experiments were conducted [11] using an Ocean Optics® portable fluorescence device with the following components:

USB 200 spectrometer with spectral grating #2 (UV/Vis 600), LS-1 lamp (380 nm) in LS-450 housing, UV-2 casting, OFLV linear filter 200-850, L2 collection lens and slit-200.

Tests were carried out in relative irradiance mode using 2- or 5-second integration times.

The method was evaluated using beryllium oxide spiked onto mixed cellulose ester (MCE) filters at levels of (0, 0.02, 0.1, 0.2, 0.3, 0.4, 1.5, 3.0, and 6.0) μg (five samples at each level) [12]. The procedure was also evaluated on polyvinyl alcohol (PVA) wipes in an interlaboratory trial with media spiked with BeO at 0.030, 0.16, 0.32, 1.8, 2.8 and 5.6 μg [7].

Long-term stability of samples was verified from spikes (number [n] = 30) of 0.1 μg Be on MCE filters [9]. Samples were analyzed at day one (n = 12) and then one week (n = 6), ten days (n = 3), two weeks (n = 3), three weeks (n = 3), and one month (n = 3) after spiking. No diminution of fluorescence signal was observed from samples prepared and analyzed after having been stored for up to thirty days.

Interference tests were carried out using solutions of 0 nmol/L, 100 nmol/L, and 1.0 $\mu\text{mol/L}$ Be in the presence of 0.4 mmol/L Al, Ca, Co, Cu, Fe, Ti, Li, Ni, Pb, Sn, U, V, W, or Zn (separate experiments were carried out for each potential interferant) [13]. Interlaboratory evaluations of the method were also performed [4,7,14].

The method using the lysine-free detection solution was compared and tested (with the detection solution with lysine for comparison) (Table 4) and this was carried out on a Glomax™ spectrometer (Turner Biosystems, Sunnyvale, CA) with an emission filter of 475 ± 5 nm and the excitation was at 360 nm

REFERENCES:

- [1] US Department of Energy [1999]. 10 CFR 850, Chronic Beryllium Disease Prevention Program. Washington: Code of Federal Regulations.
- [2] Dion C, Perrault G [2005]. Summary of good cleanup and decontamination practices for workplaces with beryllium-containing dust (Publ. no. R-409). Montreal, Canada: IRSST.

- [3] Agrawal A, Cronin J, Tonazzi J, McCleskey TM, Ehler DS, Minogue EM, Whitney G, Brink C, Burrell AK, Warner B, Goldcamp MJ, Schlecht PC, Sonthalia P, Ashley K [2006]. Validation of a standardized portable fluorescence method for determining trace beryllium in workplace air and wipe samples. *J Environ Monit* 8: 619- 624.
- [4] Ashley K, Agrawal A, Cronin J, Tonazzi J, McCleskey TM, Burrell AK, Ehler DS [2007]. Ultra-trace determination of beryllium in occupational hygiene samples by ammonium bifluoride extraction and fluorescence detection using hydroxybenzoquinoline sulfonate. *Anal Chim Acta* 584: 281-286.
- [5] NIOSH [1994]. Elements by ICP (nitric/perchloric acid ashing): Method 7300 (supplement issued 3/15/03). In: NIOSH Manual of Analytical Methods. 4th ed. Cincinnati, OH: National Institute for Occupational Safety and Health, DHHS (NIOSH) Publication No. 94-113.
- [6] ASTM International [2015]. D7202 – Standard test method for determination of beryllium in the workplace using field-based extraction and fluorescence detection. West Conshohocken, PA: ASTM International.
- [7] Ashley K, Wise TJ, Marlow D, Agrawal A, Cronin JP, Adams L, Ashley E, Lee PA [2011]. Trace beryllium determination in polyvinyl alcohol wipes by extraction and fluorescence detection – Interlaboratory analysis. *Anal Methods* 3: 1906-1901.
- [8] ASTM International [2013]. D6966 - Standard practice for wipe sampling of surfaces for subsequent determination of metals. West Conshohocken, PA: ASTM International.
- [9] ASTM International [2011]. D7707 - Standard Specification for Wipe Sampling Materials for Beryllium in Surface Dust. West Conshohocken, PA: ASTM International.
- [10] Goldcamp MJ, Goldcamp DM, Ashley K, Fernback JE, Agrawal A, Millson M, Marlow D, Harrison K [2009]. Extraction of beryllium from refractory beryllium oxide with dilute ammonium bifluoride and determination by fluorescence – A multi-parameter performance evaluation. *J Occup Environ Hyg* 6: 735-744.
- [11] McCleskey TM, Agrawal A, Ashley K [2007]. Backup data—method nos. 7704 and 9110 / beryllium, Issue 1. NIOSH Docket Office, Cincinnati, Ohio 45226; e-mail: NIOSHdocket@cdc.gov.
- [12] Youmans-McDonald L, Brisson MJ, Bernard M, Agrawal A, Cronin J, Adams L [2011]. Determining beryllium by optical fluorescence using pre-wetted wipes. *J ASTM Int* 8(3) [JAI 103489].
- [13] Agrawal A, Adams LL, Agrawal A, Cronin JP, Tonazzi JCL, Duran BL [2011]. Beryllium measurement by optical fluorescence in samples contaminated by fluorescent impurities, *J ASTM Int* 8(8) [JAI 103411].
- [14] Ashley K, McCleskey TM, Brisson MJ, Goodyear G, Cronin J, Agrawal A [2005]. Interlaboratory evaluation of a portable fluorescence method for the measurement of trace beryllium in the workplace. *J ASTM Int* 2(9) [JAI13156].
- [15] Kennedy ER, Fischbach TJ, Song R, Eller PM, Shulman SA [1995]. Guidelines for air sampling and analytical method development and evaluation. Cincinnati, OH: National Institute for Occupational Safety and Health; DHHS (NIOSH) Publication No. 95-117

METHOD REVISED BY:

T. Mark McCleskey, Los Alamos National Laboratory, Los Alamos, NM; Kevin Ashley, CDC/NIOSH, Division of Applied Research and Technology; Anoop Agrawal, Berylliant Inc., Tucson, AZ.

Disclaimer: Mention of any company or product does not constitute endorsement by NIOSH. In addition, citations to websites external to NIOSH do not constitute NIOSH endorsement of the sponsoring organizations or their programs or products. Furthermore, NIOSH is not responsible for the content of these websites. All web addresses referenced in this document were accessible as of the publication date.

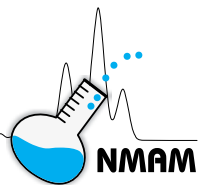

METHAMPHETAMINE on Wipes by Liquid Chromatography/Mass Spectrometry

9111

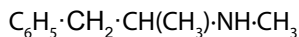

MW: 149.2

CAS: 537-46-2

RTECS: SH4910000

METHOD: 9111, Issue 1

EVALUATION: Partial

Issue 1: 17 October 2011

OSHA: None for surfaces
 NIOSH: None for surfaces
 Other OELs and guidelines: [1, 2, 3]

PROPERTIES: White solid, MP 171 - 175 °C; VP 0.163 mm Hg @ 25 °C; $pK_a = 9.87$ @ 25 °C; Water Sol. (1.33 g/100 mL @ 25 °C). Log P = 2.07 (octanol-water partition coefficient).

SYNONYMS: (S)-N, α -Dimethylbenzeneethanamine; (S)-(+)-N, α -Dimethylphenethylamine; d-1-Phenyl-2-methylaminopropane. Methedrine; Desoxy; chalk; crank; crystal; glass; ice; meth, speed; upper.

| SAMPLING | | MEASUREMENT | |
|---|---|--|---|
| SAMPLER: | Wipe | TECHNIQUE: | LIQUID CHROMATOGRAPHY/MASS SPECTROMETRY-SIM mode. See Table 1. |
| SAMPLE AREA: | 100 cm ² or 1000 cm ² | ANALYTE: | Methamphetamine |
| SHIPMENT: | Ship refrigerated preferably | DESORPTION: | 0.1 M sulfuric acid |
| SAMPLE STABILITY: | At least 7 days at 22 °C At least 30 days at <6 °C | INJECTION VOLUME: | 50 μ L |
| FIELD BLANKS: | 2 to 10 blanks per set | MOBILE PHASE: | A: 5/95 acetonitrile/water, 0.1% acetic acid B: 95/5 acetonitrile/water, 0.1% acetic acid |
| MEASUREMENT ACCURACY | | COLUMN: | 150 mm x 4.6 mm, 5 μ m film of dimethyl-n-octadecylsilane (C18) stationary phase to silica gel. Column temperature 40 °C. |
| RANGE STUDIED: | Not Determined | GRADIENT: | 100% A for one min, gradient to 100% B (9 min), hold 5 min, gradient to 100% A (2 min), hold 8 min. Flow rate is 0.50 mL/min |
| BIAS: | Not Determined | CALIBRATION: | Media spiked standards to cover the range (See Table 1) |
| OVERALL PRECISION (\hat{S}_{rT}): | Not Determined | RANGE: | 0.1 – 100 μ g/sample |
| ACCURACY: | Not Determined | ESTIMATED LOD: | 0.1 μ g/sample |
| | | PRECISION (\bar{S}_r): | 0.067 [4] |

APPLICABILITY: For methamphetamine the range is approximately 0.1 to 100 μ g/sample (sample = 100 cm²).

INTERFERENCES: No chromatographic interferences detected.

OTHER WIPE METHODS: NIOSH 9106 uses liquid-liquid extraction and gas chromatography/mass spectrometry (GC/MS) to measure multiple drugs [5]. NIOSH 9109 uses solid-phase extraction and GC/MS to measure multiple drugs [6].

REAGENTS:

1. Methamphetamine.* 1 mg/mL in methanol.
2. Methamphetamine-D₁₄ 1 mg/mL in methanol.
3. Solvents, residue free analytical grades:
 - a. Isopropanol (IPA) *
 - b. Acetic Acid *
 - c. Acetonitrile *
 - d. Methanol *
4. Concentrated sulfuric acid (AR or trace metals analysis grade).*
5. Purified gas: nitrogen for drying.
6. Deionized water (ASTM type II).

SOLUTIONS:

1. Prepare spiking solutions of target analyte and internal standard. Keep solutions refrigerated. Protect solutions from light.
 - a. Target analyte spiking solutions are prepared by diluting the 1000 µg/mL methamphetamine stock solution to 200 µg/mL and 20 µg/mL each in methanol.
 - b. Dilute 1 mL of 1000 µg/mL methamphetamine-D₁₄ stock solution to 10 mL for a 100 µg/mL (0.1 µg/µL) solution.
2. Desorption solution: 0.1 M sulfuric acid. Add 22 mL conc. sulfuric acid to 4 L deionized water.
3. Prepare Mobile Phase A: 0.1% acetic acid, 5% acetonitrile in water.
4. Prepare Mobile Phase B: 0.1% acetic acid, 95% acetonitrile in water.

* See SPECIAL PRECAUTIONS

EQUIPMENT:

1. Wipe, cotton gauze, 3" x 3" (7.6 cm x 7.6 cm) 12-ply or 4" x 4" (10.2 cm x 10.2 cm) 8-ply or equivalent.
2. Sample storage and shipping container: 50-mL polypropylene centrifuge tubes with caps or equivalent.
3. Liquid chromatograph/mass spectrometer, with integrator or computerized data collection system, and column.
4. LC autosampler vials, 2-mL, and caps.
5. Volumetric flasks: various sized flasks for making standards and spiking solutions. A 4-L bottle for making the desorption solution.
6. Liquid Transfer:
 - a. Various microliter syringes for making and spiking standard solutions.
 - b. Adjustable 10 to 50-mL desorption solution dispenser to fit 4-L bottle.
7. Forceps.
8. Latex or nitrile gloves. Avoid vinyl gloves. (See 9111-3, Sampling, Step 1, NOTE 2.)
9. Rotating mixer capable of 10 to 30 rpm.
10. Pasteur pipettes.
11. Template: 10 cm x 10 cm hole. Template made of relatively rigid disposable cardstock or sheet of PTFE.
12. Filters: Ion Chromatography filter media, 25 mm syringe filter with 0.45 µm film hydrophilic polyethersulfone (PES) membrane.
13. Ice or other cold media for shipping.

SPECIAL PRECAUTIONS: The solvents are flammable and have associated adverse health effects. Avoid breathing vapors. Avoid skin contact. Work should be performed in an adequate hood. Analysts must wear proper eye and hand protection (e.g. latex gloves) to prevent absorption of even small amounts of amines through the skin as well as for protection from the solvents and other reagents. Dissolving concentrated sulfuric acid in water is highly exothermic. Goggles must be worn.

Caution must also be exercised in the handling and analysis of samples. Clandestine drug labs may produce unknown and seriously toxic by-products.

SAMPLING:

See APPENDIX for special instructions on sampling.

1. Using a new pair of gloves, remove a gauze wipe from its protective package. Moisten the wipe with approximately 3 to 4 mL of methanol (or isopropanol).

NOTE 1: Apply no more solvent than that needed to moisten approximately the central 80% of the area of the gauze wipe. Excess solvent may cause sample loss due to dripping from the wipe.

NOTE 2: Do not use vinyl gloves due to the potential for leaching of phthalate plasticizers and contamination of the samples.

2. Place the template over the area to be sampled (may tape in place along outside edge of template). Wipe the surface to be sampled with firm pressure, using vertical S-strokes. Fold the exposed side of the pad in and wipe the area with horizontal S-strokes. Fold the pad once more and wipe the area again with vertical S-strokes.

3. Fold the pad, exposed side in, and place in shipping container and seal with cap.

NOTE: Keep samples refrigerated (<6 °C). While methamphetamine and several related amines are stable on the recommended wipe media for at least 7 days at room temperature, refrigeration is recommended as soon as possible.

4. Clean the template before use for the next sample or use a new disposable template.

5. Label each sample clearly with a unique sample identifier.

6. Prepare a minimum of two field blanks with one field blank for every ten samples.

NOTE: In addition, include at least 3 media blanks for the analytical laboratory to use for their purposes. The wipes used for the media blanks should be from the same lot as the field samples.

SAMPLE PREPARATION:

7. Desorption from media:

- a. Remove cap from shipping container. Sample media should fit loosely in the container. If not, rearrange media carefully with rinsed forceps or transfer to a larger container. If the sample media are transferred to a larger container, do not discard the original container. Samples may consist of more than one wipe. If this is the case, internal standard and desorption solution volumes may be adjusted accordingly.

- b. Spike exactly 50 µL of internal standard spiking solution onto each wipe sample.

- c. Add 30 mL desorption solution (0.1 M sulfuric acid). If the samples were transferred to a larger container, the original shipping container must be rinsed with the desorption solution first, shaken, and the rinsate decanted into the larger container.

- d. Cap securely and mix contents by inverting the tubes end over end on a rotary mixer at 10-30 rpm for at least one hour.

NOTE 1: The desorption solution must percolate freely through the gauze wipes.

NOTE 2: If there is reason to believe that the samples may be alkaline enough to overcome the acidity of the desorption solution (e.g. wipes of unpainted concrete or stucco surfaces), then the pH must be adjusted to about ≤ 4 . See APPENDIX for instructions.

- e. Filter an aliquot of the sample through a 0.45 µm pore coated with hydrophilic polyether sulfone on the ion chromatography filter media (25-mm diameter) for analysis.

8. Transfer the filtered sample into a vial and cap.

9. Analyze samples, standards, blanks, and Quality Control samples (QCs) by LC-MS. (See MEASUREMENT, steps 13-15.)

CALIBRATION AND QUALITY CONTROL:

10. Determine retention time using the column and chromatographic conditions specified on page 9111-1.

11. Calibrate daily with at least six media spiked calibration standards and a blank.

- a. Prepare the target analyte spiking solutions. (See SOLUTIONS, 9111-2)

- b. Prepare calibration standards and media blanks in clean shipping containers (e.g. 50-mL polypropylene centrifuge tubes.)

- c. Spike a known volume of target analyte spiking solution into each calibration standard by spiking directly onto the media. Use the spiking volumes suggested in Table 2 to cover the desired range.

- d. Analyze these along with the field samples. (See MEASUREMENT, steps 13-15.)

12. Prepare matrix-spiked and matrix-spiked duplicate quality control samples (QC and QD).
 - a. Cotton gauze from the same lot used for taking samples in the field should be provided to the analytical laboratory to prepare these matrix-spiked QC samples.
 - b. The quality control samples (QC and QD) must be prepared independently at concentrations within the analytical range. (See Table 2 for applicable concentration ranges.)
 - c. One quality control media blank (QB) must be included with each QC and QD pair.
 - d. The quality control samples must be prepared at the rate of one set (QB, QC, and QD) per 20 samples or less.
 - e. Transfer clean gauze wipes to new shipping containers.
NOTE: If two gauze wipes were used for the majority of samples in an analytical set, use two clean gauze wipes for each QB, QC, and QD.
 - f. Spike QC and QD with a known amount of target analyte as suggested in Table 2.
 - g. Process quality control samples along with the calibration standards, blanks, and field samples through steps 7 and 8.
 - h. Analyze these along with the calibration standards, blanks, and field samples. (See MEASUREMENT, steps 13-15.)

MEASUREMENT:

13. Analyze the calibration standards, quality control samples, blanks, and samples by LC-MS.
 - a. Use the following suggested analytical sequence.
 - i. Calibration standards.
 - ii. Matrix spiked quality control samples (QC and QD), one set for every 20 samples or less.
 - iii. A media blank (QB), one for every 20 samples or less.
 - iv. Samples (up to 10) including one sample duplicate.
 - v. A continuing calibration verification (CCV) standard consisting of one of the initial calibration standards.
 - vi. A media blank.
 - b. Set liquid chromatograph according to manufacturer's recommendations and to conditions listed previously.
 - c. Set mass spectrometer to scan for ions 119, 150, and 164 in SIM mode. Further suggestions for MS conditions are listed in Table 1 but will vary for particular instruments and conditions. See Note 2 in Table 1.
 - d. Inject 50 μ L of the sample aliquot into liquid chromatograph.
 - e. After analysis, the vials should be promptly recapped and refrigerated if further analysis is anticipated. Samples are stable refrigerated for at least seven days.
14. Using extracted ion current profiles for the primary (quantification) ions specific to methamphetamine and the internal standard, measure the LC peak area of each respective peak and compute relative peak areas by dividing the peak area of the analyte by the area of the internal standard. Recommended primary (quantification) ions and internal standard ions are given in Table 1. Prepare a calibration graph (relative peak area vs. μ g analyte per sample).
15. Samples from initial investigations of clandestine laboratories are likely to include highly contaminated samples. If sample results exceed the upper range of the calibration curve, the sample in the LC vial may be diluted with the sulfuric acid desorption solution and reanalyzed.

CALCULATIONS:

16. Determine the mass in μ g/sample of methamphetamine found in the wipe samples and in the media blank from the calibration graph.

17. Calculate final concentration, C , of methamphetamine in $\mu\text{g}/\text{sample}$:

$$C = c \frac{V_1}{V_2} - b$$

Where:

c = concentration in sample (in $\mu\text{g}/\text{sample}$ determined from the calibration curve)

$\frac{V_1}{V_2}$ = dilution factor, if applicable

V_1 = volume in μL of internal standard spiking solution used to spike samples.

V_2 = volume in μL of internal standard spiking solution used to spike the standards.

b = concentration in media blank (in $\mu\text{g}/\text{sample}$ determined from the calibration curve).

18. Report concentration, C' , in μg per total area wiped (in cm^2) as follows:

$$C' = \frac{C}{A}$$

Where:

C = $\mu\text{g}/\text{sample}$ (step 17).

A = Total area wiped in cm^2 per sample.

NOTE: For example, if the sample was a composite sample and the area was 400 cm^2 , report results as $\mu\text{g}/400 \text{ cm}^2$. In general, if the area wiped was greater than or less than 100 cm^2 , do not convert value to $\mu\text{g}/100 \text{ cm}^2$. To avoid confusion, report separately both $\mu\text{g}/\text{sample}$ (C) and the total area wiped in cm^2 per sample (A) for both discrete and composite samples.

EVALUATION OF METHOD:

This method was evaluated for methamphetamine over a range of approximately $0.4 \mu\text{g}/\text{sample}$ to $17.8 \mu\text{g}/\text{sample}$ on cotton gauze. These concentration levels represent approximately 3 through 100 times the limit of quantitation (LOQ) level. Results are reported in the Backup Data Report for 9111s[4].

The limit of detection (LOD) and LOQ were determined by preparing a series of media spiked standards, desorbing in the sulfuric acid desorption solution and analyzing in the SIM mode. The LODs were estimated using the procedure of Burkart [7]. An LOD of less than $0.02 \mu\text{g}/\text{sample}$ for methamphetamine on wipes was achieved in the SIM mode. The LOD was set at $0.05 \mu\text{g}/\text{sample}$ and the LOQ at $0.15 \mu\text{g}/\text{sample}$ for method development purposes. Lower LODs can be achieved in practice by including calibration standards at lower concentration levels and with proper instrument maintenance. The cleanliness and performance of the mass spectrometer must be maintained such that at a minimum of $0.1 \mu\text{g}/\text{sample}$ a signal of at least 5 to 10 times the baseline noise is achievable.

Precision and accuracy were determined by analyzing 6 replicates at each of 4 concentration levels (nominally 0.44 , 1.8 , 4.4 , and $18 \mu\text{g}/\text{sample}$). Accuracy was calculated using equations and methodology found in the NIOSH Technical Report "Guidelines for Air Sampling and Analytical Method Development and Evaluation" [8]. Using all data, method precision (S_r) was 0.06663 . Accuracy was 20.7% and mean bias was -0.09753 .

Long term sample storage stability was determined for periods up to 30 days under refrigeration ($4 \text{ }^\circ\text{C} \pm 2 \text{ }^\circ\text{C}$) and for up to 7 days at room temperature ($22\text{-}24 \text{ }^\circ\text{C}$). Since long term storage measures only the viability of

analytes on a particular media over time, this determination was not repeated for this particular method; the reader is directed to NIOSH 9106 [5] for more detail. All recoveries were found to be 93.5% or better.

Recovery of amphetamines from six different types of surfaces using cotton gauze was evaluated. The study and results are reported in NIOSH 9109 [6]. The practice of serial wiping (wiping the same surface area a second time with a second gauze wipe and combining both wipes as a single sample) was evaluated. Four solvents for wetting the gauze were tested (distilled water, 5% distilled white vinegar, isopropanol, and methanol). Six replicate samples were taken on a latex painted wall. Recovery and precision results are presented in the previously mentioned Backup Data Report. In summary, the effectiveness of the various solvents using a single wipe on a latex painted wall were as follows: water, 46% recovery; 5% distilled white vinegar, 55% recovery; isopropanol, 64% recovery and methanol, 87% recovery. Average recoveries with isopropanol from all the surfaces tested were greatly improved with a repeat (serial) wipe (11% improvement compared to only about 6% improvement with methanol). The serial wipe is added to the first wipe and constitutes a single sample.

REFERENCES:

- [1] ACGIH [2013]. TLVs and BEIs based on the documentation of the Threshold Limit Values for chemical substances and physical agents and Biological Exposure Indices. Cincinnati, Ohio: American Conference of Governmental Industrial Hygienists. [www.acgih.org]. Data accessed April 2014.
- [2] Institut für Arbeitsschutz der Deutschen Gesetzlichen Unfallversicherung [2013]. GESTIS database on hazardous substances (German Social Accident Insurance). Sankt Augustin, FRG: [http://www.dguv.de/ifa/GESTIS]. Data accessed April 2014.
- [3] EPA [2013]. Voluntary guidelines for methamphetamine laboratory cleanup. [https://www.epa.gov/sites/production/files/documents/meth_lab_guidelines.pdf]. Date accessed March 2016.
- [4] Siso MC, McKay TT, Reynolds JM, Wickman DC [2005]. Backup data report for NIOSH 9111, Methamphetamine on wipes by liquid chromatography-mass spectrometry. Unpublished. Prepared under NIOSH Contract 200-2001-0800.
- [5] NIOSH [2011]. Methamphetamine and illicit drugs, precursors, and adulterants on wipes by liquid-liquid extraction: Method 9106. In: Ashley KA, O'Connor PF, eds. NIOSH manual of analytical methods. 5th ed. Cincinnati, OH: U.S. Department of Health and Human Services, Centers for Disease Control and Prevention, National Institute for Occupational Safety and Health, [www.cdc.gov/niosh/nmam/].
- [6] NIOSH [2011]. Methamphetamine and illicit drugs, precursors, and adulterants on wipes by solid phase extraction: Method 9109. In: Ashley KA, O'Connor PF, eds. NIOSH manual of analytical methods. 5th ed. Cincinnati, OH: U.S. Department of Health and Human Services, Centers for Disease Control and Prevention, National Institute for Occupational Safety and Health, [www.cdc.gov/niosh/nmam/].
- [7] Burkart JA [1986]. General procedures for limit of detection calculations in the industrial hygiene chemistry laboratory. *Appl Ind Hyg* 1(3):153-155.
- [8] NIOSH [1995]. NIOSH Technical Report: Guidelines for air sampling and analytical method development and evaluation. By Kennedy ER, Fischbach TJ, Song R, Eller PM, Shulman SA. Cincinnati, OH: U.S. Department of Health and Human Services, Public Health Services, Centers for Disease Control and Prevention, National Institute for Occupational Safety and Health, DHHS (NIOSH) Publication No. 95-117.
- [9] Serrano KA, Martyny JW, Kofford S, Contreras JR, Van Dyke MV [2012]. Decontamination of clothing and building materials associated with the clandestine production of methamphetamine. *J Occup Environ Hyg* 9(3):185-197.
- [10] Van Dyke MV, Serrano KA, Kofford S, Contreras J, Martyny JW [2011]. Variability and specificity associated with environmental methamphetamine sampling and analysis. *J Occup Environ Hyg* 8(11):636-41.

METHOD DEVELOPMENT BY:

Maria Carolina Siso, Thomas T. McKay, John M. Reynolds, and Don C. Wickman, DataChem Laboratories, Inc., Salt Lake City, Utah under NIOSH Contract CDC 200-2001-0800.

Disclaimer: Mention of any company or product does not constitute endorsement by NIOSH. In addition, citations to websites external to NIOSH do not constitute NIOSH endorsement of the sponsoring organizations or their programs or products. Furthermore, NIOSH is not responsible for the content of these websites. All web addresses referenced in this document were accessible as of the publication date.

Table 1. Suggested Mass Spectrometer SIM Conditions

| | |
|--------------------|--|
| Ionization Mode: | API-ES (Atmospheric Pressure Ionization –Electrospray) |
| Polarity: | Positive |
| Fragmentator: | 100 |
| Gain: | 3.0 EMV |
| Actual Dwell: | 294 |
| SIM ions: | 119 Methamphetamine confirmation ion |
| | 150 Quantitation ion for methamphetamine |
| | 164 Ion for methamphetamine-D ₁₄ |
| Spray Chamber: | (Optimize for the particular instrument in use.) |
| Gas Temperature: | 200 °C |
| Drying Gas: | 12.0 L/min |
| Nebulizer Pressure | 50 psig |

Note 1: Methamphetamine and the internal standard essentially co-elute. Monitor *m/z* ions 119 and 150 for methamphetamine quantitation and 164 for methamphetamine-D₁₄.

Note 2: These instrumental conditions are suggestions and should be optimized by the analyst. Each mass spectrometer will be different and the acid concentration and composition will alter the conditions. Furthermore there is the possibility of using MS/MS for these analyses if the laboratory is equipped with that instrumentation. This tandem MS could add specificity and sensitivity to the method but was not part of this method development.

Table 2. Suggested spiking schedule for calibration standards

| Standard | Volume (μL) of Methamphetamine Spiking Solution Spiked on Media | | Internal Standard Spike (μL) | Desorption Solution (mL) | Final Concentration ($\mu\text{g}/\text{sample}$) |
|----------|--|-------------------------------------|---|--------------------------|---|
| | 200 $\mu\text{g}/\text{mL}$ solution | 20 $\mu\text{g}/\text{mL}$ solution | | | |
| 1 | 500 | | 50 | 30 | 100 |
| 2 | 100 | | 50 | 30 | 20 |
| 3 | 25 | | 50 | 30 | 5 |
| 4 | 5 | | 50 | 30 | 1 |
| 5 | | 25 | 50 | 30 | 0.5 |
| 6 | | 5 | 50 | 30 | 0.1 |
| 7 | | 2.5 | 50 | 30 | 0.05 |
| 8 | | 1.2 | 50 | 30 | 0.024 |

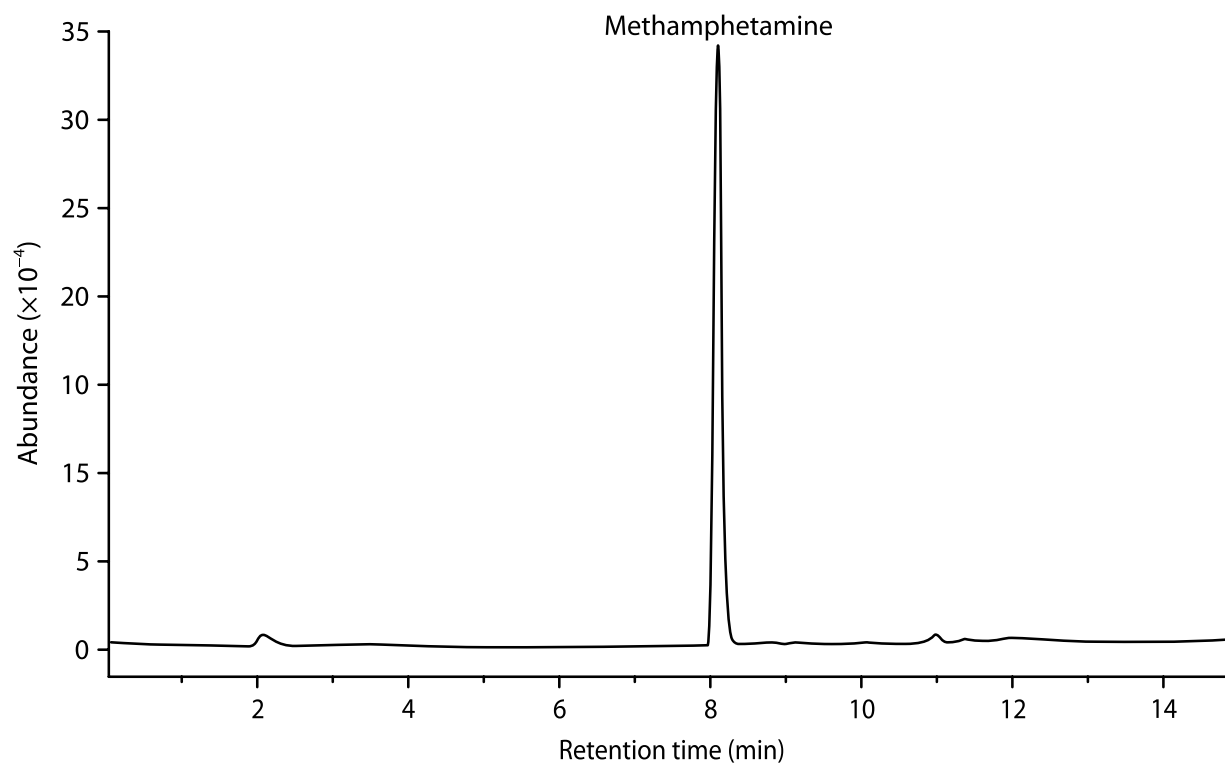
Figure 1. LC-MS total ion chromatogram of methamphetamine (m/z 119, 150, 164).

APPENDIX:**SAMPLING**

NOTE: For further information and data on the effects of surface composition and porosity as well as the use of different solvents on the efficacy of wipe sampling, please see reports by Serrano et al [9] and Van Dyke et al [10].

1. Follow specific requirements of surface area to be wiped (usually 100 cm²) and action threshold (or maximum allowable residual level) set by the agency having legal jurisdiction or specified by the client. Uptake rates depend upon the wipe sampling method used so the specific wipe technique used must be specified and any deviations from the required wipe sampling requirements noted.
2. The following steps only summarize the overall sampling procedure and are not intended to be used as a shortcut or wipe sampling procedures that may be specified by the legal jurisdiction or the client.
3. Prepare a rigid template from disposable cardstock or a sheet of PTFE having either a 10 cm x 10 cm or 1 ft x 1 ft (1000 cm²) square hole cut according to the dimensions required by the regulatory agency. The template must be able to retain its shape during wiping to ensure that the areas wiped were 100 cm² or 1 ft². Single-use disposable cardstock is preferred because it eliminates the possibility for cross-contamination and the necessity to take a blank wipe between samples in step 3.
4. Provide enough wipe media from the same lot to cover all required laboratory media blanks, field-equipment blanks, samples and sample duplicates, and quality control samples. Use gauze in sterile packaging to minimize the chance for cross-contamination which might more easily occur with open bulk packaged cotton gauze. The gauze wipes needed for the laboratory media blanks and QC samples are to be sent to the laboratory in their unopened sterile packages.
5. Secure the template(s) to the area(s) to be wiped (e.g. with tape along outside edge of template). If a single-use disposable template is not used, clean the template between samples to avoid cross-contamination and provide laboratory with a blank wipe of the cleaned template between samples to ensure that no cross-contamination has occurred.
6. With freshly gloved hand, take one gauze and wet it with isopropanol or methanol (about 3-4 mL for either the 3" x 3" (7.5 cm x 7.5 cm) 12-ply or the 4" x 4" (10 cm x 10 cm) 8-ply cotton gauze wipes). Alternatively, pre-wet and insert the gauze wipes into the sample containers off-site. This avoids any possibility of the bottle of methanol or isopropanol becoming contaminated on-site with methamphetamine. If the wipes were prepared off-site, then remove pre-wetted gauze wipe from sample container, opening only one sample container at a time. In either case, squeeze out and discard any excess solvent from the gauze wipe. Use fresh latex or nitrile gloves for each separate sample and blank. Do not use vinyl gloves due to the potential for leaching of phthalate plasticizers and contamination of the samples.
7. Wipe Techniques
 - a. Concentric Squares Wiping Technique (particularly suitable for smooth and non-porous surfaces): Fold the pre-wetted gauze in half and then fold in half again. Using firm pressure wipe the area within the template. Start at one of the inside corners of the template and wipe in concentric squares, progressing toward the center. End with a scooping motion. Without allowing the gauze to touch any other surface, reverse the last fold so that the exposed side of the gauze is facing inward and using a fresh surface of the gauze, wipe the same area in the same manner as before. Roll or fold the gauze again and insert into the shipping container.
 - b. Side-to-side Wiping (or Blotting) Technique (particularly suitable for rough, porous, and/or soiled surfaces): Fold the pre-wetted gauze in half and then fold in half again. Using firm pressure wipe or blot the area within the template with at least five overlapping side-to-side horizontal passes (see NOTE) beginning at the top and progressing to the bottom in a "Z" pattern. End with a scooping motion. If blotting, blot at least five times on each horizontal pass (see NOTE). Without allowing the gauze to touch any other surface, reverse the last fold so that the exposed side of the gauze is facing inward. Using a fresh surface of the gauze, wipe or blot the area again with at least five overlapping top-to-bottom vertical passes beginning at the left side and progressing to the right in an "N" pattern.

If blotting, blot at least five times on each vertical pass. Roll or fold the gauze again and insert into the shipping container. Blotting is suggested in areas so soiled or rough that the threads of the gauze media are continually snagged.

NOTE: On areas larger than 100 cm², more than five passes and blots will be needed.

- c. Repeat or Serial Wiping: If isopropanol is used for wiping, a serial or repeat wipe sample of the same area with a fresh gauze wipe will improve sampling efficiency. For serial wiping, repeat the wiping procedure described above (APPENDIX 7a or 7b) with a fresh gauze wipe. Place the second gauze wipe into the same shipping container as the first gauze. The 50-mL polypropylene centrifuge tubes are large enough to contain up to two gauze wipes of either the 3" x 3" 12-ply or 4" x 4" 8-ply sizes.

NOTE: If the area to be wiped remains substantially wet from the first gauze, the second gauze wipe might be used in the dry state to soak up the residual solvent from the first gauze wipe.

8. Cap shipping containers securely and keep refrigerated (<6 °C). Make sure caps are not cross-threaded. Containers must have no chips, fractures, or other irregularities on the sealing edge. Do not use polyethylene plastic bags. While methamphetamine and several related amines are stable on the recommended wipe media for at least 7 days at room temperature, refrigeration is recommended as soon as possible.
9. Label each sample clearly with a unique sample identification number or name, and the date, time, location, and initials or identification number of the individual taking the sample. The above information and a description of the sample and the area wiped should also be recorded in a logbook for later correlation with the analytical results.

SAMPLE PREPARATION

Samples requiring pH adjustment: If there is reason to believe that the samples may be alkaline enough to overcome the acidity of the desorption solution (e.g. wipes of unpainted concrete or stucco surfaces), then the pH must be adjusted to about ≤ 4 . The pH may be checked with pH paper or monitored with the addition of about 2 drops of the mixed pH indicator solution of bromothymol blue and phenolphthalein. (The color should be yellow and not green or blue.) The preparation of this indicator solution can be found in NIOSH 9106 or NIOSH 9109 [5, 6]. If the pH needs to be adjusted, a solution of dilute (2.5 to 3 M) sulfuric acid is used and added dropwise. Mix the contents by shaking or inversion a few times by hand after each addition of acid before checking the pH.